

TEST REPORT relevant to Bluetooth Low Energy transmitter Secondo i seguenti Standard / According to following Standards	
Test Methods	ANSI C63.4: 2014-06 ANSI C63.10: 2013-06 FCC KDB 558074 D01: 2019-04
Test specification	FCC Rules: Code of Federal Regulations (CFR) no. 47 Part 15 Subpart C Section 15.247, 15.205, 15.203, 15.207, 15.209 Test plan: Test_Plan_RADIO_for_TRIUMPH_5INCH&7INCH_rev_9: 24/02/2021, Issue date: 21/08/2020
Maximum Peak Output Power, FCC Section 15.247 (b) (3)	Conforme / Compliant
Maximum Power Spectral Density, FCC Section 15.247(e)	Conforme / Compliant
6 dB Bandwidth & 99%, FCC Section 15.247 (a) (2)	Conforme / Compliant
Band-edge Compliance, Section 15.247(d)	Conforme / Compliant
Conducted Spurious Emissions, Section 15.247(d)	Conforme / Compliant
Radiated Spurious Emissions, FCC Section 15.205 (a), 15.209, 15.247(d)	Conforme / Compliant
Restricted Bands of Operation, Section 15.205	Conforme / Compliant
Antenna Requirement, FCC Section 15.203	Conforme / Compliant
Richiedente/ Applicant's name:	MTA S.p.A.
Indirizzo / Address:	Viale dell'Industria, 12 - 26845 Codogno (LO) - Italy
Produttore / Manufacturer:	MTA S.p.A.
Indirizzo / Address:	Viale dell'Industria, 12 - 26845 Codogno (LO) - Italy
Dispositivo sottoposto ai test/ Device Under Test:	Instrument panel TRIUMPH 7INCH
Data di emissione/ Date of issue	11 th March 2021
Validità/ Validity	Vedi sezione 1.2 / See section 1.2
Test report redatto da/ Author of Test report	Loris Fruch
Tecnico/i di prova Engineer/s	Loris Fruch, Rudy Valent
Approvato da (+ firma) Approved by (+ signature)	Silvano Chialina Responsabile del laboratorio/ Head of the Laboratory
Laboratorio / Testing Laboratory	Emilab Srl a Socio Unico
Indirizzo / Address:	Via F.Ili Solari 5/A – 33020 Amaro (UD) - Italy

Index

1.0	INFORMAZIONI GENERALI / GENERAL INFORMATION	5
1.1	Laboratorio / <i>Testing Laboratory</i>	5
1.2	Campionamento e Documentazione / <i>Sampling and Documentation</i>	5
1.3	Specifiche del test / <i>Test specifications</i>	5
1.4	Svolgimento dei test e condizioni generali / <i>Test scheduling and general condition</i>	6
1.5	Espressione dei risultati finali / <i>Test case of final verdicts</i>	6
1.6	Incertezza / <i>Uncertainty</i>	6
1.7	Termini, Definizioni e Acronimi / <i>Terms, definitions and abbreviations</i>	7
2.0	APPARECCHIATURA SOTTOPOSTA A TEST / DEVICE UNDER TEST	8
2.1	Descrizione del dispositivo e informazioni sul setup / <i>Device description and setup information</i>	8
2.2	Scostamenti dalle condizioni specificate / <i>Deviations from the specified conditions</i>	9
2.3	Lista dei Canali / <i>Channel List</i>	10
2.4	Modalità di Test e Dettagli dei Canali / <i>Test Modes and Channel Details</i>	10
3.0	MAXIMUM CONDUCTED OUTPUT POWER – CONDIZIONI DI PROVA / TEST CONDITIONS	11
3.1	Apparecchiature utilizzate / <i>Test Equipment Used</i> – Maximum Conducted Output Power	11
3.2	Fotografie del setup / <i>Photo of the test setup</i> – Maximum Conducted Output Power	12
3.3	Requisiti / <i>Requirements</i> – Maximum Conducted Output Power	12
3.4	Risultati / <i>Results</i> – Maximum Conducted Output Power	12
4.0	MAXIMUM POWER SPECTRAL DENSITY – CONDIZIONI DI PROVA / TEST CONDITIONS	14
4.1	Apparecchiature utilizzate / <i>Test Equipment Used</i> – Maximum Power Spectral Density	14
4.2	Fotografie del setup / <i>Photo of the test setup</i> – Maximum Power Spectral Density	15
4.3	Requisiti / <i>Requirements</i> – Maximum Power Spectral Density	15
4.4	Risultati / <i>Results</i> – Maximum Power Spectral Density	15

5.0	BANDWIDTH – CONDIZIONI DI PROVA / TEST CONDITIONS	17
5.1	Apparecchiature utilizzate / <i>Test Equipment Used</i> – Bandwidth	17
5.2	Fotografie del setup / <i>Photo of the test setup</i> – Bandwidth	18
5.3	Requisiti / <i>Requirements</i> – Bandwidth	18
5.4	Risultati / <i>Results</i> – Bandwidth	18
6.0	BAND-EDGE COMPLIANCE – CONDIZIONI DI PROVA / TEST CONDITIONS	20
6.1	Apparecchiature utilizzate / <i>Test Equipment Used</i> – Band-edge Compliance	20
6.2	Fotografie del setup / <i>Photo of the test setup</i> – Band-edge Compliance	21
6.3	Requisiti / <i>Requirements</i> – Band-edge Compliance	21
6.4	Risultati / <i>Results</i> – Band-edge Compliance	21
7.0	CONDUCTED SPURIOUS EMISSIONS – CONDIZIONI DI PROVA / TEST CONDITIONS	23
7.1	Apparecchiature utilizzate / <i>Test Equipment Used</i> – Conducted Spurious Emissions	23
7.2	Fotografie del setup / <i>Photo of the test setup</i> – Conducted Spurious Emissions	24
7.3	Requisiti / <i>Requirements</i> – Conducted Spurious Emissions	24
7.4	Risultati / <i>Results</i> – Conducted Spurious Emissions	24
8.0	SPURIOUS RADIATED EMISSIONS AND RESTRICTED BANDS OF OPERATION – CONDIZIONI DI PROVA / TEST CONDITIONS	27
8.1	Apparecchiature utilizzate / <i>Test Equipment Used</i> – Spurious Radiated Emissions and Restricted Bands of Operation	28
8.2	Fotografie del setup / <i>Photo of the test setup</i> – Spurious Radiated Emissions and Restricted Bands of Operation	29
8.3	Requisiti / <i>Requirements</i> – Spurious Radiated Emissions and Restricted Bands of Operation	30
8.4	Risultati / <i>Results</i> – Spurious Radiated Emissions and Restricted Bands of Operation	31
9.0	ANTENNA REQUIREMENT – CONDIZIONI DI PROVA / TEST CONDITIONS	46
	ALLEGATO 1 / ANNEX 1 – INCERTEZZA / UNCERTAINTY	47
A.1.1	Measurement of Environmental parameters	47
A.1.2	Radio test	47

A.1.3 Radiated Spurious Emissions: FCC

47

1.0 Informazioni Generali / General Information

1.1 Laboratorio / Testing Laboratory

Luogo di Prova e partecipanti/ Testing location and participants:	
Testing Laboratory:	
Testing location/ address	Emilab Srl a Socio Unico Via F.lli Solari 5/A – 33020 Amaro (UD) – Italy Tel +39 0433 468625 Fax +39 0433 494739 Email: info.emilab@applus.com
Partecipanti / Participants:	/

1.2 Campionamento e Documentazione / Sampling and Documentation

<p>I campioni, eventuali specifici simulatori ed accessori hardware e software, di seguito chiamati <i>apparati ausiliari</i> e le informazioni specifiche su essi (campioni ed apparati ausiliari), sono stati consegnati dal Cliente sotto la propria responsabilità. I risultati dei test contenuti in questo documento si riferiscono esclusivamente al modello e numero di serie provato in combinazione con gli eventuali <i>apparati ausiliari</i>. E' responsabilità del costruttore assicurare che la produzione dei modelli in serie rispetti i requisiti del presente documento. Il laboratorio declina ogni responsabilità relativamente agli <i>apparati ausiliari</i> e alle informazioni forniti dal cliente. Questo documento non può essere riprodotto in parte senza il consenso scritto del responsabile del laboratorio EMILAB.</p> <p>EMILAB non si assume nessuna responsabilità per danni derivanti da interpretazioni che esulano dal contesto e dall'applicazione del presente documento.</p> <p><i>The samples and any specific hardware and software simulators and accessories, hereinafter called auxiliary apparatus and the related information (samples and auxiliary apparatus) was delivered by customer under his own responsibility. The results contained in this report reflect the results for this particular model and serial number tested in combination with the auxiliary apparatuses. It is the responsibility of the manufacturer to ensure that all production models meet the intent of the requirements detailed within this report. The laboratory takes no responsibility for the auxiliary equipment and for the information provided by the customer. This report shall not be reproduced, except in full, without the written approval of the Issuing testing Emilab laboratory.</i></p> <p><i>EMILAB takes no responsibility for and will not assume liability for damages resulting from the reader's interpretation of the reproduced material due to its placement and context.</i></p>
--

1.3 Specifiche del test / Test specifications

Test performed according to:	
Test plan	Test_Plan_RADIO_for_TRIUMPH_5INCH&7INCH_rev_9 Number: TP153-17 Issue Date: 21/08/2020 Revision date: 24/02/2021 Author: R. Nunnari – MTA S.p.A.
Test specification	All compliance measurements have been carried out using the procedures described in the standard ANSI C63.4-2014, ANSI C63.10-2013, Section 15.31 of CFR47 Part 15 – Subpart A (General) FCC Rules: Code of Federal Regulations (CFR) no. 47 Part 15 Subpart C Section 15.247, 15.205, 15.207, 15.209
Test Method/Basic Standard	ANSI C63.4: 2014-06 American National Standard for Methods of Measurement of Radio-Noise Emissions from Low-Voltage Electrical and Electronic Equipment in the Range of 9KHz to 40GHz. ANSI C63.10: 2013-06 American National Standard of Procedures for Compliance Testing of Unlicensed Wireless Devices KDB 558074 D01: 2019-04 Guidance for compliance measurements on digital transmission system, frequency hopping spread spectrum system, and hybrid system devices operating under section 15.247 of the FCC rules.

1.4 Svolgimento dei test e condizioni generali / *Test scheduling and general condition*

Svolgimento dei test/ Scheduling	
Data ricezione EUT	
<i>Date of receipt of EUT</i>	23/12/2020
Data esecuzione test	
<i>Date (s) of performance of tests</i>	20/01/2021 - 17/02/2021
Numero EUT / <i>EUT Number</i>	20LA00545/01 (EUT with external RF antenna connectors), 20LA00545/02 (normal product)
Condizioni ambientali <i>/ Environment Conditions</i>	Se non diversamente specificato / <i>If not otherwise specified:</i> Temperature: 18-28°C Humidity: 20-90% Pressure: 87-108.56 kPa
Intervallo delle tarature/ <i>Calibration Interval</i>	Minimum 1 year

1.5 Espressione dei risultati finali / *Test case of final verdicts*

I risultati considerano l'incertezza di misura, ove applicabile, mediante lo schema seguente <i>/ The results consider the measurement uncertainty, where applicable, using the following scheme</i>	
- test case does not apply to the test object.. :	N/A (Not Applicable)
- test object does meet the requirement	Compliant or PASS
- test object does not meet the requirement . :	Not Compliant or FAIL

1.6 Incertezza / *Uncertainty*

L'incertezza estesa riportata è espressa come l'incertezza tipo moltiplicata per il fattore di copertura $k = 2$, che per una distribuzione normale corrisponde ad una probabilità di copertura di circa il 95 %.

The reported expanded uncertainty of measurements is stated as the standard uncertainty of measurement, multiplied by the coverage factor $k=2$, which for a normal distribution corresponding to a coverage probability of approximately 95%.

1.7 Termini, Definizioni e Acronimi / *Terms, definitions and abbreviations*

AC	Alternating Current
ACK	Acknowledgement
AFH	Adaptive Frequency Hopping
AM	Amplitude Modulation
AVE det	Average Detector
BIT	Burst Interval Time
CAC	Channel Availability Check
BW	BandWidth
CCA	Clear Channel Assessment
CW	Continuous Wave
DAA	Detect And Avoid
DC	Duty Cycle DFS
DFS	Dynamic Frequency Selection
DSSS	Direct Sequence Spread Spectrum
DUT	Device Under Test
e.i.r.p.	equivalent isotropically radiated power
e.r.p.	effective radiated power
EMC	ElectroMagnetic Compatibility
EUT	Equipment Under test
FAR	Fully Anechoic Room
FHSS	Frequency Hopping Spread Spectrum
HT20 High	Throughput in a 20 MHz channel
HT40 High	Throughput in a 40 MHz channel
ISM	Industrial, Scientific and Medical
LBT	Listen Before Talk
LPDA	Logarithmic Periodic Dipole Antenna
MCS	Modulation Coding Scheme
MIMO	Multiple Input, Multiple Output
MU	Medium Utilization
MS/s	Mega-Samples per second
NACK	Not Acknowledged
OATS	Open Air Test Site
OFDM	Orthogonal Frequency Division Multiplexing
OM	Operating Modes
OOB	Out Of Band
PK det	Peak Detector
PM	Pulse Modulation
Ppm	Parts per million
PPS	Pulses Per Second
PRF	Pulse Repetition Frequency
RBW	Resolution BandWidth
RE	Radiated Emission
RLAN	Radio Local Area Network
RMS	Root Mean Square
R&TTE	Radio and Telecommunications Terminal Equipment
RF	Radio Frequency
Rx	Receiver
SAC	Semi Anechoic Chamber
TEM	Transverse Electromagnetic
TL	Threshold Level
TPC	Transmit Power Control
Tx	Transmitter
VBW	Video BandWidth
VSWR	Voltage Standing Wave Ratio
WLAN	Wireless Local Area Network
BT	Bluetooth
BLE	Bluetooth Low Energy

2.0 Apparecchiatura sottoposta a test / *Device Under Test*

2.1 Descrizione del dispositivo e informazioni sul setup / *Device description and setup information*

Queste informazioni sono fornite dal cliente sotto la propria responsabilità / *These information are provided by the customer under his own responsibility*

Descrizione/ Description	Instrument panel TRIUMPH
Marchio commercial / <i>Trade Mark</i>	
Produttore / <i>Manufacturer</i>	MTA S.p.A.
Modello / <i>Model/Type reference</i>	Version 7INCH
Voltage/Current.....	14V DC (nominal voltage)
Current	1A
Frequency	/
Power.....	/
Serial Number	S/N: 00121, batch: 450 (20LA00545/01) S/N: 00045, batch: 450 (20LA00545/02)
Numero di campioni testati / <i>Number of samples tested</i>	1+1
Numero EUT del produttore / <i>Internal customer EUT Number</i>	MTA P/N: 6100354/11 TRIUMPH P/N: 2506607
Hardware stage/level	04.04.00.00
Software stage/level	01.07.05.00.00.10
Modification stage	/
Operating Mode	Mode 1: during the tests the EUT was powered at 14V DC and was connected to the EMC RF structure which in turn was connected to the Box Sim Opto Tx by an optical fiber. The EMC RF structure was also connected by CAN and LIN bus to the PC using optical converters. For radiated tests the Box Sim Opto Tx and the PC were placed outside the anechoic chamber. The EUT is programmed with customer application software which periodically tests the whole functionality of the instrument panel (CFG diagnostic test, analog inputs, digital inputs, LOAD, Bus LIN, memory EEPROM, RF radio module BT&BLE, etc.). The EUT radio modules are set to perform the radio tests on BT&BLE with different modulations (hopping or fixed channel). Mode 2: during the tests the EUT was powered at 14V DC and was connected to the EMC RF structure which in turn was connected to the Box Sim Opto Tx by an optical fiber. The EMC RF structure was also connected by CAN and LIN

	<p>bus to the PC.</p> <p>Bluetooth antenna output (50ohm, SMA) was connected to the Spectrum Analyser.</p> <p>The EUT is programmed with customer application software which periodically tests the whole functionality of the instrument panel (CFG diagnostic test) and the EUT radio modules are set to perform the radio tests on different channels/modulations of BT&BLE.</p> <p>During all tests, the EUT BT transmitter was set at its maximum Tx-power, as per control software setting.</p>																								
Wiring harness	Harness type 1 (1.7m -0.0/+0.3m)																								
Monitoring	/																								
Info	Auxiliary equipment provided by the applicant:																								
	<table border="1"> <thead> <tr> <th><i>Equipment</i></th> <th><i>Model</i></th> <th><i>Serial Number</i></th> <th><i>Manufacturer</i></th> </tr> </thead> <tbody> <tr> <td>Personal Computer</td> <td>Latitude 3570</td> <td>885</td> <td>DELL</td> </tr> <tr> <td>USB/CAN converter</td> <td>CAN Case XL</td> <td>007129052509</td> <td>Vector</td> </tr> <tr> <td>EMC RF structure</td> <td>-</td> <td>-</td> <td>MTA</td> </tr> <tr> <td>Tester RF Triumph</td> <td>-</td> <td>-</td> <td>MTA</td> </tr> <tr> <td>Box Sim Opto Tx</td> <td>-</td> <td>-</td> <td>MTA</td> </tr> </tbody> </table>	<i>Equipment</i>	<i>Model</i>	<i>Serial Number</i>	<i>Manufacturer</i>	Personal Computer	Latitude 3570	885	DELL	USB/CAN converter	CAN Case XL	007129052509	Vector	EMC RF structure	-	-	MTA	Tester RF Triumph	-	-	MTA	Box Sim Opto Tx	-	-	MTA
<i>Equipment</i>	<i>Model</i>	<i>Serial Number</i>	<i>Manufacturer</i>																						
Personal Computer	Latitude 3570	885	DELL																						
USB/CAN converter	CAN Case XL	007129052509	Vector																						
EMC RF structure	-	-	MTA																						
Tester RF Triumph	-	-	MTA																						
Box Sim Opto Tx	-	-	MTA																						

2.2 Scostamenti dalle condizioni specificate / *Deviations from the specified conditions*

Scostamenti dalle condizioni specificate / *Deviation from the specified conditions*: N/A

2.3 Lista dei Canali / Channel List

Bluetooth Low Energy

Frequency band [MHz]: 2400 – 2483.5			
Channel	Frequency [MHz]	Channel	Frequency [MHz]
37	2402	19	2442
0	2404	20	2444
1	2406	21	2446
2	2408	22	2448
3	2410	23	2450
4	2412	24	2452
5	2414	25	2454
6	2416	26	2456
7	2418	27	2458
8	2420	28	2460
9	2422	29	2462
10	2424	30	2464
11	2428	31	2466
12	2430	32	2468
13	2432	33	2470
14	2434	34	2472
15	2436	35	2474
16	2438	36	2476
17	2440	38	2426
18	2442	39	2480

2.4 Modalità di Test e Dettagli dei Canali / Test Modes and Channel Details

Bluetooth Low Energy

Test Description	Channel Frequency	Modulation	Data Rate
Maximum Peak Output Power, FCC Section 15.247 (b) (3)	2402 / 2440 / 2480	GFSK	1Mbps (BR)
Maximum Power Spectral Density, FCC Section 15.247(e)	2402 / 2440 / 2480	GFSK	1Mbps (BR)
6 dB Bandwidth & 99%, FCC Section 15.247 (a) (2)	2402 / 2440 / 2480	GFSK	1Mbps (BR)
Band-edge Compliance, FCC Section 15.247(d)	2402 / 2480	GFSK	1Mbps (BR)
Conducted Spurious Emissions, FCC Section 15.247(d)	2402 / 2440 / 2480	GFSK	1Mbps (BR)
Radiated Spurious Emissions, FCC Section 15.205 (a), 15.209, 15.247(d)	Worst case detected during Max Peak Output Power test	-	-
Restricted Bands of Operation, Section 15.205	Worst case detected during Max Peak Output Power test	-	-
Antenna Requirement/ Transmit Antenna, FCC Section 15.203	-	-	-

3.0 Maximum Conducted Output Power – Condizioni di prova / Test Conditions

Technician / Tecnico: Loris Fruch		
Table No.	TEST: Maximum Peak Output Power, FCC Section 15.247 (b) (3)	\
Method	FCC KDB 558074 D01: 2019-04, par. 8.3.2.2	\
Parameters required prior to the test	Laboratory Ambient Temperature	18 to 28 °C
	Relative Humidity	20 to 90%
Parameters recorded during the test	Laboratory Ambient Temperature	21 °C
	Relative Humidity	21 %
Supplementary information:		
<ul style="list-style-type: none"> - Test performed on EUT 20LA00545/01; - Conducted Test, executed at Bluetooth antenna output (50ohm, SMA) connected to the Spectrum Analyser through an attenuator (30 dB); - EUT powered at 14Vdc; - EUT Operating Mode: Mode 2 (see par. 2.1); - Spectrum analyser settings setup: <ul style="list-style-type: none"> • Detector: Peak • RBW: 3MHz and VBW=3MHz • Instrument mode: Max Hold - Test executed on BLE CHIP 1 (Phones) with the following settings: <ul style="list-style-type: none"> • BLE mode with modulation GFSK on channel 37, 17 and 39 with data rate at 1Mbps 		

3.1 Apparecchiature utilizzate / Test Equipment Used – Maximum Conducted Output Power

<i>Apparecchiature usate/Equipment Used</i>	<i>Modello/Model</i>	<i>Costruttore/Manufacturer</i>	<i>Numero di serie/Serial Number</i>	<i>Data calibrazione / Calibration date</i>	<i>Intervallo / Interval</i>
EMI Receiver MXE	N9038A	Agilent Technologies	MY51210230	07/2020	1 year
30dB Attenuator	PE7087-30	Pasternack	1349	02/2020	1 year
RF Cable	SKBL-2M-LOW	Mini-Circuits	1101189	09/2020	1 year
DataLogger T/UR	HL-1D	Rotronic	A18012240	07/2020	1 year
Dual DC Power Supply	CPX400D	TTi	482828	10/2020	1 year

3.1.1 Apparecchiature ausiliarie / Auxiliary Equipment – Maximum Conducted Output Power

<i>Apparecchiature /Equipment</i>	<i>Modello/Model</i>	<i>Costruttore/Manufacturer</i>	<i>Numero di serie/Serial Number</i>	<i>Data calibrazione / Calibration date</i>	<i>Intervallo / Interval</i>
Signal Generator	8648D	HP	3642U01713	02/2020	1 year

3.2 Fotografie del setup / Photo of the test setup – Maximum Conducted Output Power

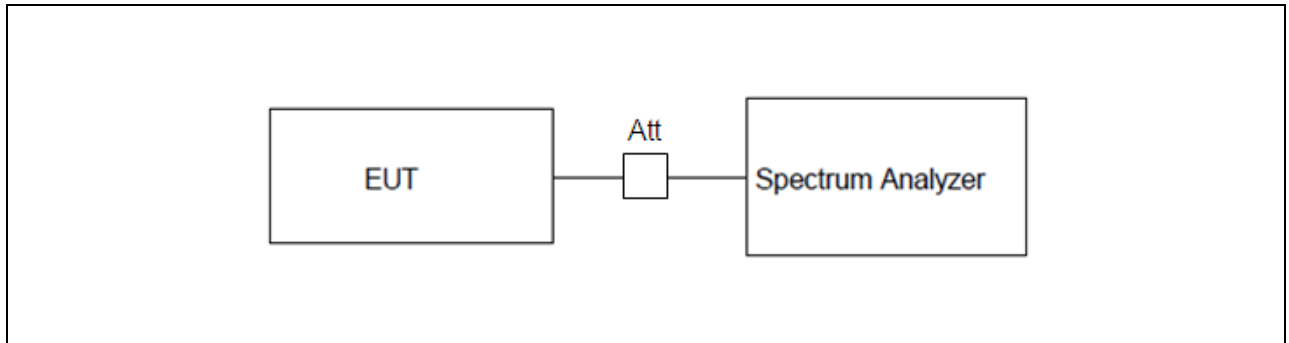

3.3 Requisiti / Requirements – Maximum Conducted Output Power

FCC Section 15.247

- (b) The maximum peak conducted output power of the intentional radiator shall not exceed the following:
- (3) For systems using digital modulation in the 902-928 MHz, 2400-2483.5 MHz, and 5725-5850 MHz bands: 1 Watt. As an alternative to a peak power measurement, compliance with the one Watt limit can be based on a measurement of the maximum conducted output power. Maximum Conducted Output Power is defined as the total transmit power delivered to all antennas and antenna elements averaged across all symbols in the signaling alphabet when the transmitter is operating at its maximum power control level. Power must be summed across all antennas and antenna elements. The average must not include any time intervals during which the transmitter is off or is transmitting at a reduced power level. If multiple modes of operation are possible (e.g., alternative modulation methods), the *maximum conducted output power* is the highest total transmit power occurring in any mode.

3.4 Risultati / Results – Maximum Conducted Output Power

The result of the test is: **PASS**.

See the details in the charts/tables of the following paragraphs (see the worst case in bold text).

3.4.1 Tabelle e grafici dei risultati / Tables and graphical representation of data – Maximum Conducted Output Power

Note: all the traces reported in this section have been obtained with Peak detector, Max Hold.

Measures executed on BLE active on CHIP 1 (Phones)

Modulation mode	Data Rate (Mbps)	Channel Frequency (MHz)	Peak Output Power (dBm)	Limit (dBm)	Margin (dB)
BLE GFSK	1	2402,0	1,48	30,0	28,5
		2440,0	0,16	30,0	29,8
		2480,0	0,60	30,0	29,4

Channel Freq: 2402 MHz, (BLE, GFSK) Data Rate: 1Mbps

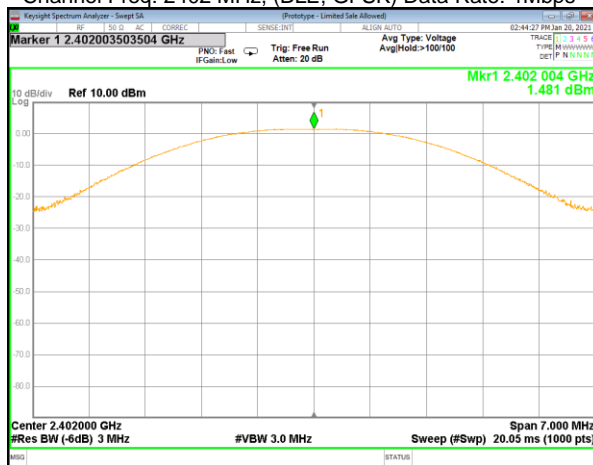

Channel Freq: 2440 MHz, (BLE, GFSK) Data Rate: 1Mbps

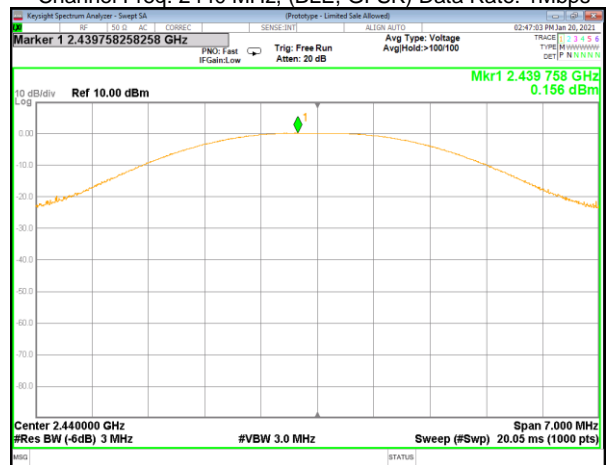

Channel Frequency: 2480 MHz, (BLE, GFSK) Data Rate: 1Mbps

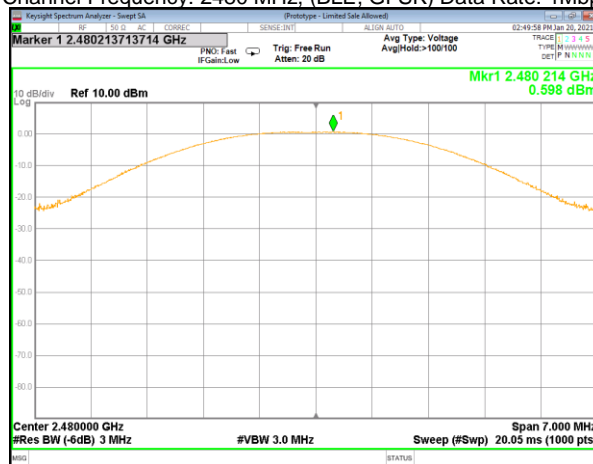

4.0 Maximum Power Spectral Density – Condizioni di prova / Test Conditions

Technician / Tecnico: Loris Fruch		
Table No.	TEST: Maximum Power Spectral Density, FCC Section 15.247(e)	\
Method	FCC KDB 558074 D01: 2019-04, par. 8.4	\
Parameters required prior to the test	Laboratory Ambient Temperature	18 to 28 °C
	Relative Humidity	20 to 90 %
Parameters recorded during the test	Laboratory Ambient Temperature	22 °C
	Relative Humidity	21 %
Supplementary information:		
<ul style="list-style-type: none"> - Test performed on EUT 20LA00545/01; - Conducted Test, executed at Bluetooth antenna output (50ohm, SMA) connected to the Spectrum Analyser through an attenuator (30 dB). - EUT powered at 14Vdc; - EUT Operating Mode: Mode 2 (see par. 2.1); - Spectrum analyser settings setup (peak PSD): <ul style="list-style-type: none"> • Detector: Peak, Trace: max hold (over last 100 sweeps), • RBW: 3 kHz and VBW=100 kHz, • Sweep Control: auto couple (SR=stimulus/response). - Test executed on BLE CHIP 1 (Phones) with the following settings: <ul style="list-style-type: none"> • BLE mode with modulation GFSK on channel 37, 17 and 39 with data rate at 1Mbps 		

4.1 Apparecchiature utilizzate / Test Equipment Used – Maximum Power Spectral Density

Apparecchiature usate/Equipment Used	Modello/Model	Costruttore/Manufacturer	Numero di serie/Serial Number	Data calibrazione / Calibration date	Intervallo / Interval
EMI Receiver MXE	N9038A	Agilent Technologies	MY51210230	07/2020	1 year
30dB Attenuator	PE7087-30	Pasternack	1349	02/2020	1 year
RF Cable	SKBL-2M-LOW	Mini-Circuits	1101189	09/2020	1 year
DataLogger T/UR	HL-1D	Rotronic	A18012240	07/2020	1 year
Dual DC Power Supply	CPX400D	TTi	482828	10/2020	1 year

4.1.1 Apparecchiature ausiliarie / Auxiliary Equipment – Maximum Power Spectral Density

Apparecchiature /Equipment	Modello/Model	Costruttore/Manufacturer	Numero di serie/Serial Number	Data calibrazione / Calibration date	Intervallo / Interval
Signal Generator	8648D	HP	3642U01713	02/2020	1 year

4.2 Fotografie del setup / *Photo of the test setup* – Maximum Power Spectral Density

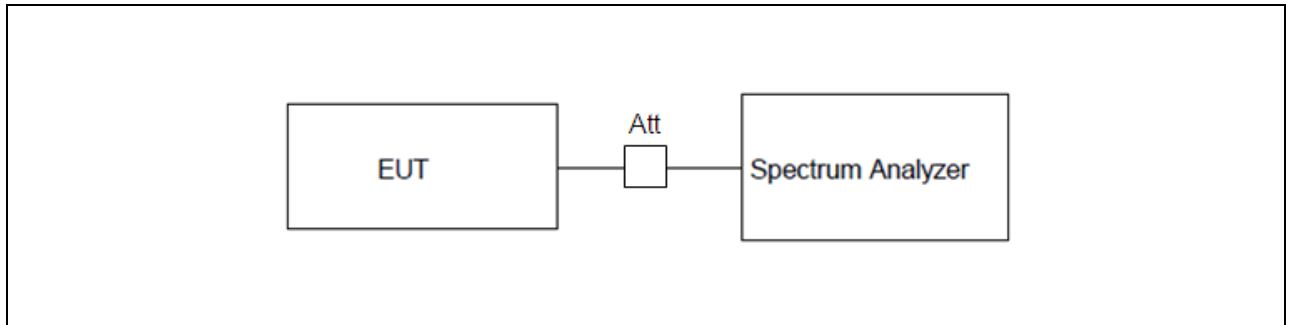

4.3 Requisiti / *Requirements* – Maximum Power Spectral Density

FCC Section 15.247

(e) For digitally modulated systems, the power spectral density conducted from the intentional radiator to the antenna shall not be greater than 8 dBm in any 3 kHz band during any time interval of continuous transmission. This power spectral density shall be determined in accordance with the provisions of paragraph (b) of this section. The same method of determining the conducted output power shall be used to determine the power spectral density.

4.4 Risultati / *Results* – Maximum Power Spectral Density

The result of the test is: **PASS**.

See the details in the charts/tables of the following paragraphs (see the worst case in bold text).

4.4.1 Tabelle e grafici dei risultati / *Tables and graphical representation of data* – Maximum Power Spectral Density

Note: all the traces reported in this section have been obtained with Peak detector, max hold (over last 100 sweeps); RBW=3kHz:

Measures executed on BLE (DTS) active on CHIP 1 (Phones)

Modulation mode	Data Rate (Mbps)	Channel Frequency (MHz)	Total PSD (dBm/3KHz)	Limit (dBm/3KHz)	Margin (dB)
BLE GFSK	1	2402,0	-10,98	8,0	19,0
		2440,0	-13,74	8,0	21,7
		2480,0	-13,25	8,0	21,3

Channel Freq: 2402 MHz, (BLE, GFSK) Data Rate: 1Mbps



Channel Freq: 2440 MHz, (BLE, GFSK) Data Rate: 1Mbps

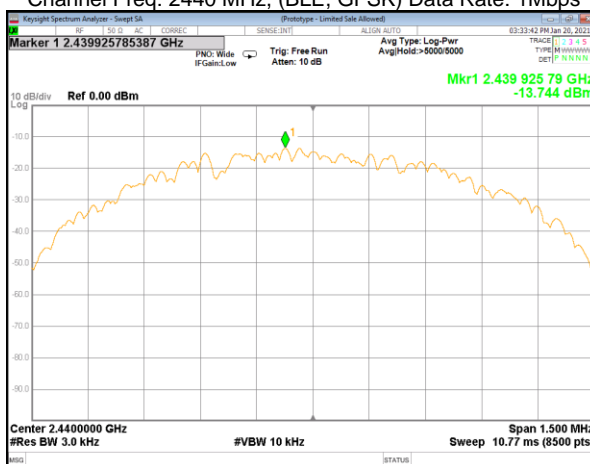

Channel Frequency: 2480 MHz, (BLE, GFSK) Data Rate: 1Mbps



5.0 Bandwidth – Condizioni di prova / Test Conditions

Technician / Tecnico: Loris Fruch		
Table No.	TEST: 6 dB Bandwidth & 99%, FCC Section 15.247 (a) (2)	\
Method	FCC KDB 558074 D01: 2019-04, par. 8.2	\
Parameters required prior to the test	Laboratory Ambient Temperature	18 to 28 °C
	Relative Humidity	20 to 90 %
Parameters recorded during the test	Laboratory Ambient Temperature	22 °C
	Relative Humidity	24 %
Supplementary information:		
<ul style="list-style-type: none"> - Test performed on EUT 20LA00545/01; - Conducted Test, executed at Bluetooth antenna output (50ohm, SMA) connected to the Spectrum Analyser through an attenuator (30 dB); - EUT powered at 14Vdc; - EUT Operating Mode: Mode 2 (see par. 2.1); - Spectrum analyser settings setup (automatic bandwidth measurement): <ul style="list-style-type: none"> • Detector: Peak • Trace: max hold (over last 10 sweeps) • RBW: 100 kHz and VBW=3xRBW - Test executed on BLE CHIP 1 (Phones) with the following settings: <ul style="list-style-type: none"> • BLE mode with modulation GFSK on channel 37, 17 and 39 with data rate at 1Mbps 		

5.1 Apparecchiature utilizzate / Test Equipment Used – Bandwidth

<i>Apparecchiature usate/Equipment Used</i>	<i>Modello/Model</i>	<i>Costruttore/Manufacturer</i>	<i>Numero di serie/Serial Number</i>	<i>Data calibrazione / Calibration date</i>	<i>Intervallo / Interval</i>
EMI Receiver MXE	N9038A	Agilent Technologies	MY51210230	07/2020	1 year
30dB Attenuator	PE7087-30	Pasternack	1349	02/2020	1 year
RF Cable	SKBL-2M-LOW	Mini-Circuits	1101189	09/2020	1 year
DataLogger T/UR	HL-1D	Rotronic	A18012240	07/2020	1 year
Dual DC Power Supply	CPX400D	TTi	482828	10/2020	1 year

5.2 Fotografie del setup / Photo of the test setup – Bandwidth

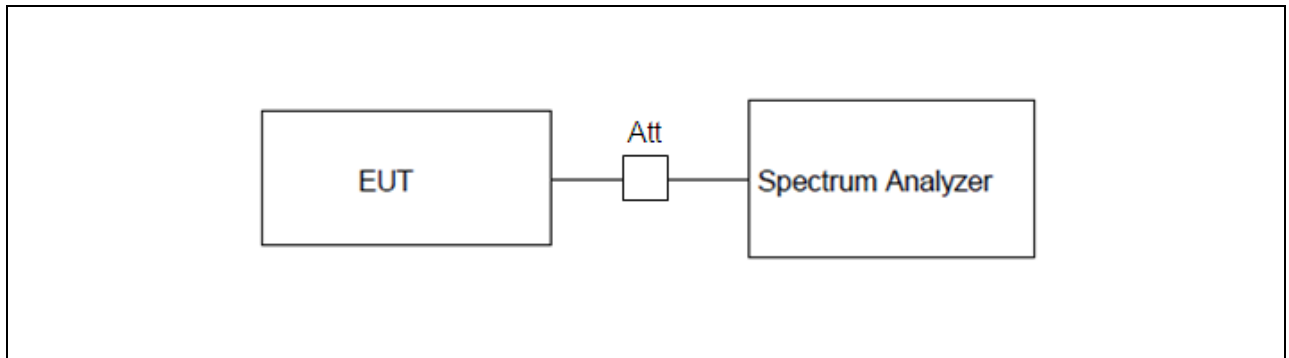

5.3 Requisiti / Requirements – Bandwidth

FCC Section 15.247

- (a) Operation under the provisions of this Section is limited to frequency hopping and digitally modulated intentional radiators that comply with the following provisions:
- (2) Systems using digital modulation techniques may operate in the 902-928 MHz, 2400-2483.5 MHz, and 5725-5850 MHz bands. The minimum 6 dB bandwidth shall be at least 500 kHz.

5.4 Risultati / Results – Bandwidth

BLE (Bluetooth Low Energy):

Section 15.247 (a) (2) The minimum specified 6dB bandwidth for digital modulated is 500 kHz, thus the result of the test is: **PASS**.

See the details in the charts/tables of the following paragraphs.

5.4.1 Tabelle e grafici dei risultati / Tables and graphical representation data – Bandwidth

Measures executed on BLE (DTS) active on CHIP 1 (Phones)

Modulation mode	Data Rate (Mbps)	Channel Frequency (MHz)	6dB Bandwidth (MHz)	99% Bandwidth (MHz)
BLE GFSK	1	2402,0	0,706	1,102
		2440,0	0,729	1,107
		2480,0	0,684	1,101

Channel Freq: 2402 MHz, (BLE, GFSK) Data Rate: 1Mbps

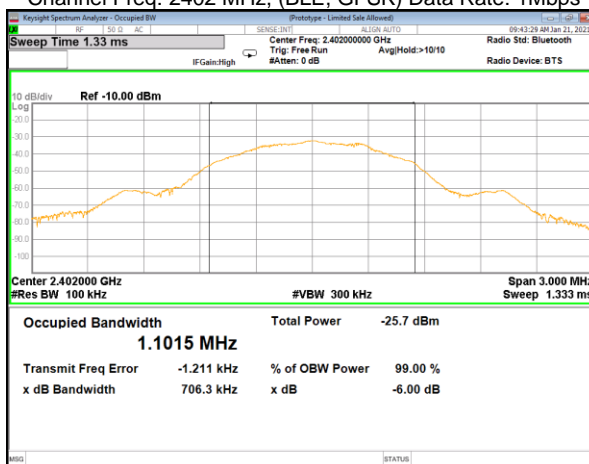

Channel Freq: 2440 MHz, (BLE, GFSK) Data Rate: 1Mbps

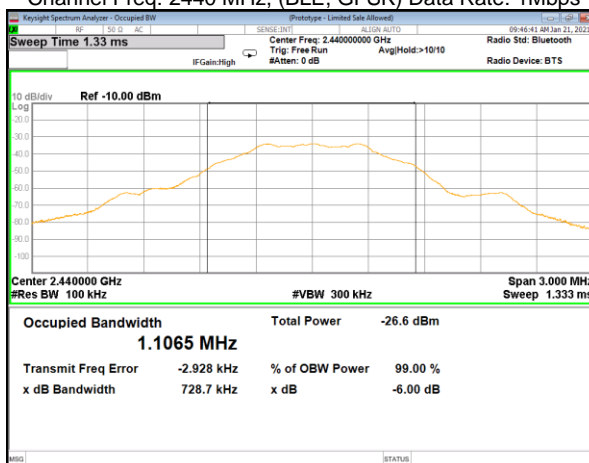

Channel Frequency: 2480 MHz, (BLE, GFSK) Data Rate: 1Mbps

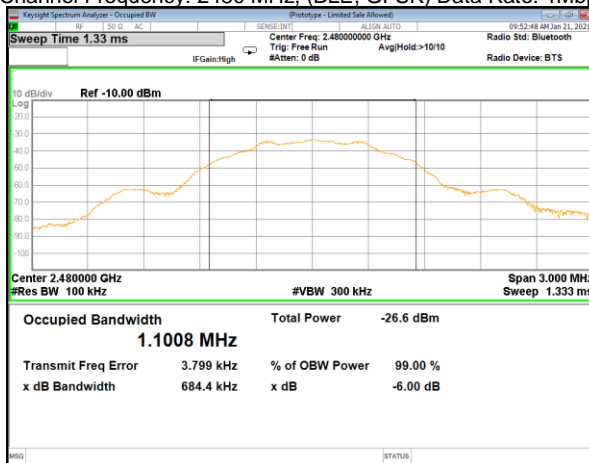

6.0 Band-edge Compliance – Condizioni di prova / Test Conditions

Technician / Tecnico: Loris Fruch		
Table No.	TEST: Band-edge Compliance, FCC Section 15.247(d)	\
Method	FCC KDB 558074 D01: 2019-04, par. 8.7.2	\
Parameters required prior to the test	Laboratory Ambient Temperature	18 to 28 °C
	Relative Humidity	20 to 90 %
Parameters recorded during the test	Laboratory Ambient Temperature	22 °C
	Relative Humidity	26 %
Supplementary information:		
<ul style="list-style-type: none"> - Test performed on EUT 20LA00545/01; - Conducted Test, executed at Bluetooth antenna output (50ohm, SMA) connected to the Spectrum Analyser through an attenuator (30 dB); - EUT powered at 14Vdc; - EUT Operating Mode: Mode 2 (see par. 2.1); - Spectrum analyser settings setup (marker delta method): <ul style="list-style-type: none"> • Detector: Peak • Trace: max hold (over last 100 sweeps) • RBW: 100 kHz and VBW=300 kHz - Applicable limit: 20dBc (output power conformity assessed using Peak detector); - Test executed on BLE CHIP 1 (Phones) with the following settings: <ul style="list-style-type: none"> • BLE mode with modulation GFSK on channel 37, 17 and 39 with data rate at 1Mbps 		

6.1 Apparecchiature utilizzate / Test Equipment Used – Band-edge Compliance

<i>Apparecchiature usate/Equipment Used</i>	<i>Modello/Model</i>	<i>Costruttore/Manufacturer</i>	<i>Numero di serie/Serial Number</i>	<i>Data calibrazione / Calibration date</i>	<i>Intervallo / Interval</i>
EMI Receiver MXE	N9038A	Agilent Technologies	MY51210230	07/2020	1 year
30dB Attenuator	PE7087-30	Pasternack	1349	02/2020	1 year
RF Cable	SKBL-2M-LOW	Mini-Circuits	1101189	09/2020	1 year
DataLogger T/UR	HL-1D	Rotronic	A18012240	07/2020	1 year
Dual DC Power Supply	CPX400D	TTi	482828	10/2020	1 year

6.2 Fotografie del setup / Photo of the test setup – Band-edge Compliance

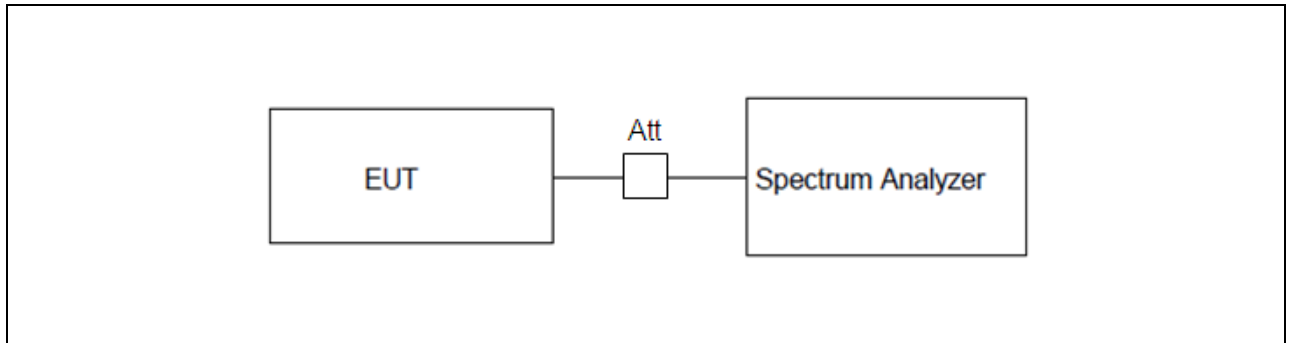

6.3 Requisiti / Requirements – Band-edge Compliance

FCC Section 15.247

(d) In any 100 kHz bandwidth outside the frequency band in which the spread spectrum or digitally modulated intentional radiator is operating, the radio frequency power that is produced by the intentional radiator shall be at least 20 dB below that in the 100 kHz bandwidth within the band that contains the highest level of the desired power, based on either an RF conducted or a radiated measurement, provided the transmitter demonstrates compliance with the peak conducted power limits. If the transmitter complies with the conducted power limits based on the use of RMS averaging over a time interval, as permitted under paragraph (b)(3) of this section, the attenuation required under this paragraph shall be 30 dB instead of 20 dB. Attenuation below the general limits specified in §15.209(a) is not required. In addition, radiated emissions which fall in the restricted bands, as defined in §15.205(a), must also comply with the radiated emission limits specified in §15.209(a) (see §15.205(c)).

6.4 Risultati / Results – Band-edge Compliance

The amplitude of spurious emissions is lower than 20 dBc, thus the result of the test is: **PASS**.
See the details in the charts of the following paragraphs.

6.4.1 Tabelle e grafici dei risultati / Tables and graphical representation of data – Band-edge Compliance

Measures executed on BLE (DTS) active on CHIP 1 (Phones)

Modulation mode	Data Rate (Mbps)	Max Signal Frequency (MHz)	Max Signal (dBm)	Frequency of Max OOB signal (MHz)	Max OOB Signal (dBm)	Value (dBc)	Limit (dBc)
BLE	1	2402,1	-32,1	2375,0	-82,14	50,0	20,0
		2479,9	-33,8	2490,7	-81,60	47,8	20,0

Channel Freq: 2402 MHz, (BLE GFSK) Data Rate: 1Mbps

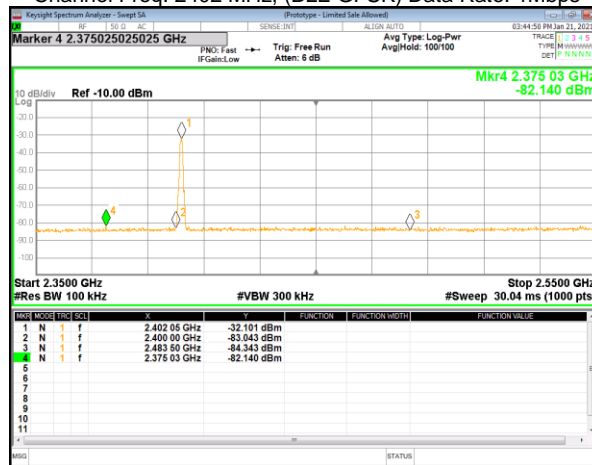

Channel Freq: 2480 MHz, (BLE GFSK) Data Rate: 1Mbps

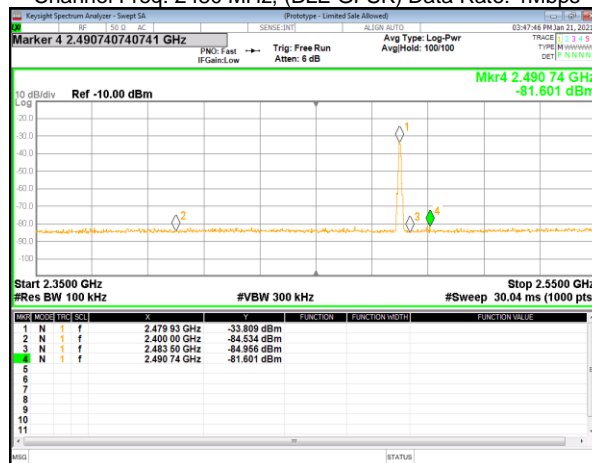

7.0 Conducted Spurious Emissions – Condizioni di prova / Test Conditions

Technician / Tecnico: Loris Fruch		
Table No.	TEST: Conducted Spurious Emissions, Section 15.247 (d)	\
Method	FCC KDB 558074 D01: 2019-04, par. 8.5	\
Parameters required prior to the test	Laboratory Ambient Temperature	18 to 28 °C
	Relative Humidity	20 to 90 %
Parameters recorded during the test	Laboratory Ambient Temperature	22 °C
	Relative Humidity	28 %
Supplementary information:		
<ul style="list-style-type: none"> - Test performed on EUT 20LA000545/01; - Conducted Test, executed at Bluetooth antenna output (50ohm, SMA) connected to the Spectrum Analyser through an attenuator (30 dB); - Frequency range of the measurements: up to 26GHz. - EUT powered at 14Vdc; - EUT Operating Mode: Mode 2 (see par. 2.1); - Spectrum analyser setting: <ul style="list-style-type: none"> • Detector= Peak, • Trace= max hold (over last 20 sweeps), • RBW= 100 kHz and VBW=300 kHz, - Test aim is to verify that in any 100 kHz bandwidth outside the frequency band in which the digitally modulated intentional radiator is operating, the radio frequency power that is produced by the intentional radiator is at least 20 dB below that in the 100 kHz bandwidth within the band that contains the highest level of the desired power. - Test executed on BLE CHIP 1 (Phones) with the following settings: <ul style="list-style-type: none"> • BLE mode with modulation GFSK on channel 37, 17 and 39 with data rate at 1Mbps 		

7.1 Apparecchiature utilizzate / Test Equipment Used – Conducted Spurious Emissions

<i>Apparecchiature usate/Equipment Used</i>	<i>Modello/Model</i>	<i>Costruttore/Manufacturer</i>	<i>Numero di serie/Serial Number</i>	<i>Data calibrazione / Calibration date</i>	<i>Intervallo / Interval</i>
EMI Receiver MXE	N9038A	Agilent Technologies	MY51210230	07/2020	1 year
30dB Attenuator	PE7087-30	Pasternack	1349	02/2020	1 year
RF Cable	SKBL-2M-LOW	Mini-Circuits	1101189	09/2020	1 year
DataLogger T/UR	HL-1D	Rotronic	A18012240	07/2020	1 year
Dual DC Power Supply	CPX400D	TTi	482828	10/2020	1 year

7.2 Fotografie del setup / *Photo of the test setup* – Conducted Spurious Emissions

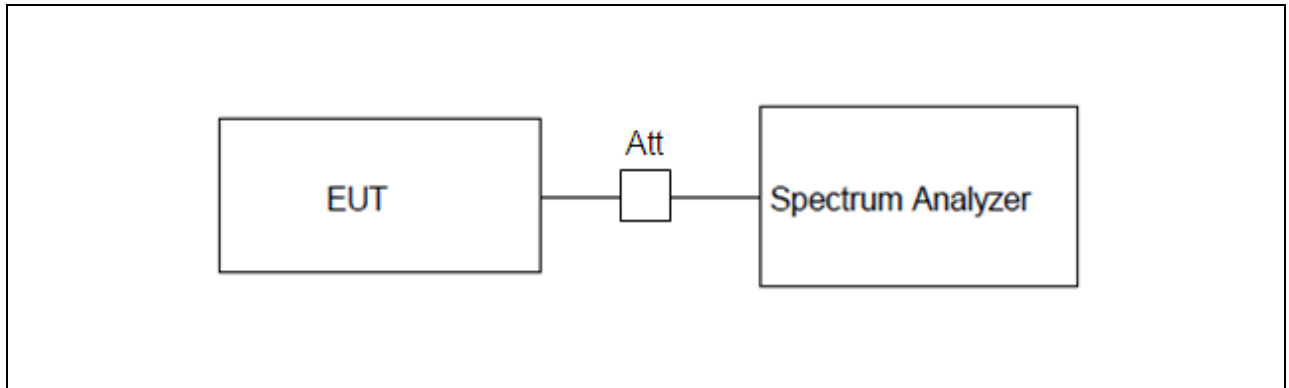

7.3 Requisiti / *Requirements* – Conducted Spurious Emissions

FCC Section 15.247

- (d) In any 100 kHz bandwidth outside the frequency band in which the spread spectrum or digitally modulated intentional radiator is operating, the radio frequency power that is produced by the intentional radiator shall be at least 20 dB below that in the 100 kHz bandwidth within the band that contains the highest level of the desired power, based on either an RF conducted or a radiated measurement, provided the transmitter demonstrates compliance with the peak conducted power limits. If the transmitter complies with the conducted power limits based on the use of RMS averaging over a time interval, as permitted under paragraph (b)(3) of this section, the attenuation required under this paragraph shall be 30 dB instead of 20 dB. Attenuation below the general limits specified in §15.209(a) is not required. In addition, radiated emissions which fall in the restricted bands, as defined in §15.205(a), must also comply with the radiated emission limits specified in §15.209(a) (see §15.205(c)).

7.4 Risultati / *Results* – Conducted Spurious Emissions

The amplitude of spurious emissions is lower than 20 dBc, thus the result of the test is: **PASS**.
See the details in the charts of the following paragraphs.

7.4.1 Grafici dei risultati / Graphical representation data – Conducted Spurious Emissions

Note: all the traces reported in this section have been obtained with detector Peak, max hold (over last 20 sweeps); RBW: 100kHz, VBW: 300kHz

Measures executed on BLE (DTS) active on CHIP 1 (Phones)

Channel Frequency: 2402 MHz, (BLE, GFSK) Data Rate: 1Mbps

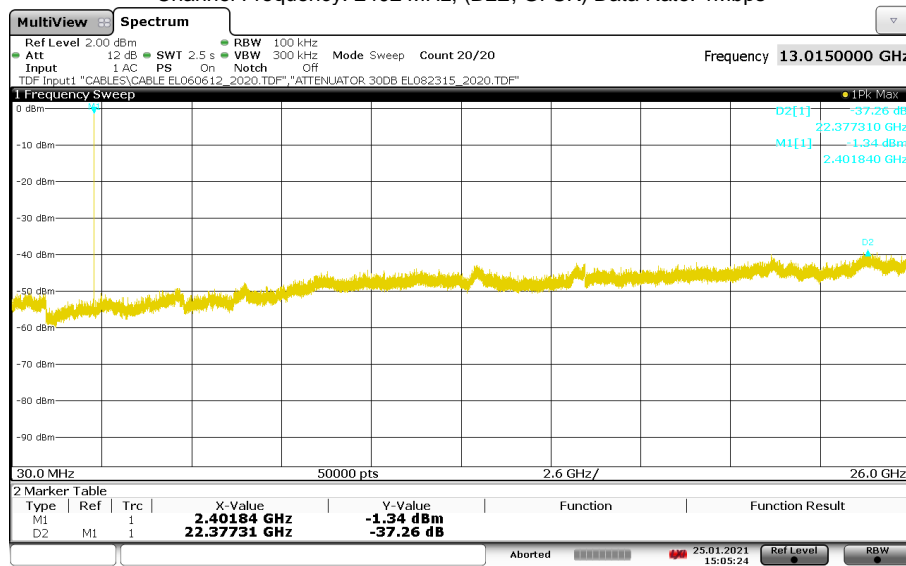

15:05:24 25.01.2021

Channel Frequency: 2440 MHz, (BLE, GFSK) Data Rate: 1Mbps

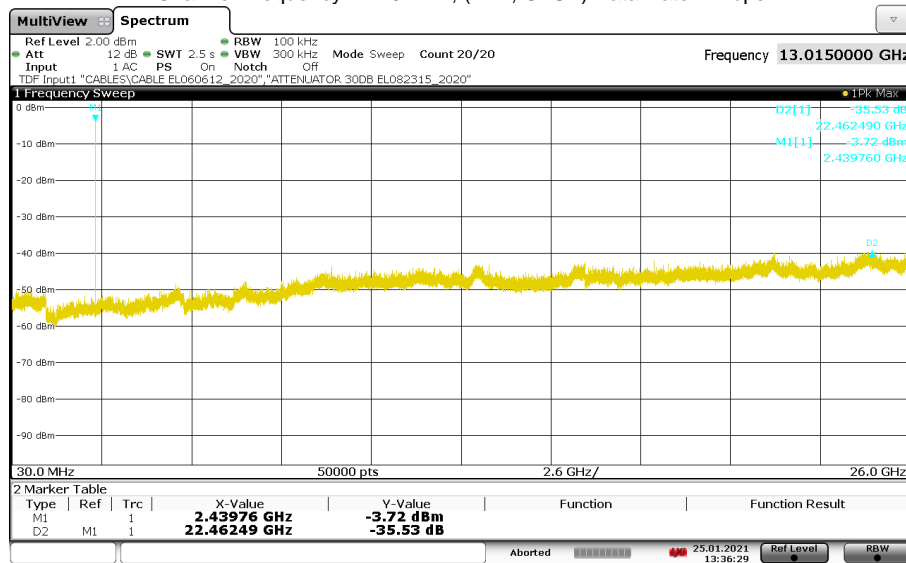

13:36:29 25.01.2021

Channel Frequency: 2480 MHz, (BLE, GFSK) Data Rate: 1Mbps

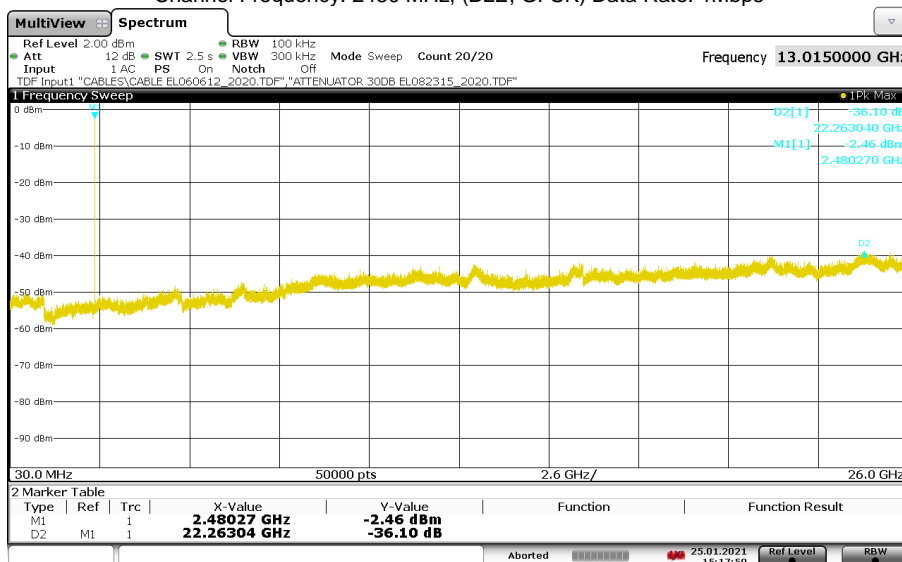

8.0 Spurious Radiated Emissions and Restricted Bands of Operation – Condizioni di prova / Test Conditions

Technician / Tecnico: Loris Fruch, Rudy Valent		
Table No.	TEST: Spurious Radiated Emissions and Restricted Bands of Operation, Section 15.205 (a), 15.209, 15.247(d)	\
Method	ANSI C63.10: 2013-06, Par. 6.3	\
Parameters required prior to the test	Laboratory Ambient Temperature	18 to 28 °C
	Relative Humidity	20 to 90 %
Parameters recorded during the test	Laboratory Ambient Temperature	21 - 23 °C
	Relative Humidity	30 - 40 %
Supplementary information:		
<ul style="list-style-type: none"> - Test performed on EUT 20LA00545/01 in operating mode 1 (see section 2.1) powered at 14Vdc. - Frequency range: 9kHz to 25GHz (tenth harmonic of the highest frequency used in the EUT), see FCC section 15.33 (a) (1); - Test site: Semi-anechoic chamber for measures from 9kHz to 1GHz and Full-anechoic chamber for measures from 1GHz to 25GHz; - The EUT was placed on turn-platform on a support at 0.8m above the ground plane for measures from 9kHz to 1GHz and on a support at 1.5m above the ground plane for measures from 1GHz to 25GHz; - The EUT was placed at 3m apart from the receiving antenna; - The turn-platform is rotated from 0° to 360° degrees to determine the position of maximum emission level, the antenna height is changed from 1m to 4m to find the highest emission; - The receiving antenna was positioned in vertical and horizontal polarization and from 1GHz to 25GHz aim the EUT (source of emission) by the use of the Accessory for azimuth antenna control, as required at section 8.3.2.2 of ANSI C63.4: 2014; - The preliminary measurements were made with the detector set to Peak within an IF bandwidth of 200Hz from 9kHz to 150kHz, of 9kHz from 150kHz to 30MHz, of 120kHz from 30MHz to 1GHz and with the detector set to Average within an IF bandwidth of 1000kHz from 1GHz to 25GHz; - Antennas used during measurements: <ul style="list-style-type: none"> • Loop antenna from 9kHz to 30MHz • Bilog antenna from 30MHz to 1GHz • Horn antenna ETS 3117 from 1GHz to 18GHz; • Horn antenna AMTP-62-20-C-SF from 18GHz to 25GHz; - The final measurements of the peaks were made with the RBW and detector set to: <ul style="list-style-type: none"> • 200Hz/Quasi-Peak from 90kHz to 150kHz (CISPR-Average from 9kHz to 90kHz); • 9kHz/Quasi-Peak from 150kHz to 30MHz (CISPR-Average from 110kHz to 490kHz); • 120kHz/Quasi-Peak from 30MHz to 1GHz; • 1MHz /CISPR-Average from 1GHz to 25GHz; - The measurements with Quasi-Peak and CISPR-Average detector were performed only for the six highest EUT emissions, excluding peaks lower than 20 dB from the limit; - FCC Limits: Sections 15.209 (a) of 47 CFR Part 15 <ul style="list-style-type: none"> Remark: In accordance with part 15.31 (f) (2) of FCC, when performing measurements at a closer distance than specified, the results shall be extrapolated to the specified distance by either making measurements at a minimum of two distances on at least one radial to determine the proper extrapolation factor or by using the square of an inverse linear distance extrapolation factor (40 dB/decade). The applied formula for limits at 3 meter is: Extrapolation (dB) = 40log (300meter / 3meter) = +80dB Extrapolation (dB) = 40log (30meter / 3meter) = +40dB - Test executed setting the BLE respect to the worst case detected during Max Peak Output Power test: <ul style="list-style-type: none"> • BLE with GFSK modulation active at 2402MHz on CHIP1 (Phones) and also at 2480MHz for Restricted Band of Operation test. 		

8.1 Apparecchiature utilizzate / Test Equipment Used – Spurious Radiated Emissions and Restricted Bands of Operation

<i>Apparecchiature usate/Equipment Used</i>	<i>Modello/Model</i>	<i>Costruttore/Manufacturer</i>	<i>Numero di serie/Serial Number</i>	<i>Data calibrazione / Calibration date</i>	<i>Intervallo / Interval</i>
EMI Receiver	ESW44	Rohde&Schwarz	101546	12/2020	1 year
Loop Antenna	6502	ETS-Lindgren	00164807	07/2020	1 year
Bilog Antenna	Bilog CBL6111C	Chase	2415	10/2018 10/2020 (verification)	3 years 1 year
Horn Antenna Double-Ridged Waveguides	3117	ETS-Lindgren	00201258	08/2018 01/2021 (verification)	3 years 1 year
Standard Gain Horn Antenna	AMTP-62-20-C-SF	SPIN Electronics	01-165-12	09/2019	3 years
High Pass Filter	VHF-7150+	Mini-Circuits	31510	11/2020	1 year
Pre-Amplifier	JS32-00104000-58-5P-R	Narda -Miteq	2008138	09/2020	1 year
RF Cable	SLULL18-NMNM	TimesMicrowave	10022-001-001	11/2020	1 year
RF Cable	SLULL18-NMNM-9.00M	Timesmicrowave	13305-001-001	06/2020	1 year
RF Cable	SFT-205-PUR	Timesmicrowave	TP105790008	09/2020	1 year
RF Cable	SFT-205-PUR	Timesmicrowave	473079-0001	09/2020	1 year
Dual DC Power Supply	CPX400DP	TTi	376596	05/2020	1 year
Dual DC Power Supply	CPX400D	TTi	482828	10/2020	1 year
DataLogger T/UR	HL-1D	Rotronic	A18012240	07/2020	1 year
LIN Optical Converter	090	EMC TOOLS	080276	-	-
LIN Optical Converter	090	EMC TOOLS	080277	-	-
HS-CAN Optical Converter	050	EMC TOOLS	040395	-	-
HS-CAN Optical Converter	050	EMC TOOLS	040383	-	-
Multi-Device Controller	2090	ETS-Lindgren	81311	-	-
Antenna Mast	2175	ETS-Lindgren	136028	-	-
Accessory for azimuth antenna control	EL088916	Emilab	-	-	-
SAC3 – DC Filter	N6006	ETS-Lindgren	202031	-	-
Semi-Anechoic Chamber	-	ETS-Lindgren	5207	06/2020	1 year

8.1.1 Apparecchiature ausiliarie / Auxiliary Equipment – Spurious Radiated Emissions and Restricted Bands of Operation

<i>Apparecchiature /Equipment</i>	<i>Modello/Model</i>	<i>Costruttore/Manufacturer</i>	<i>Numero di serie/Serial Number</i>	<i>Data calibrazione/ Calibration date</i>	<i>Intervallo / Interval</i>
Comb Generator	CG-515	COM-POWER	19104	-	-
Loop Antenna	ALR25M	Electro-Metrics	813	-	-
Signal Generator	MG3693A	Anritsu	040614	10/2020	1 year
RF Cable	SKBL-2M-LOW	Mini-Circuits	1101189	09/2020	1 year
Broadband Horn Antenna	JTXLB-20245	A-INFOMW	J2031090818001	01/2021	1 year

8.2 Fotografie del setup / *Photo of the test setup* – Spurious Radiated Emissions and Restricted Bands of Operation

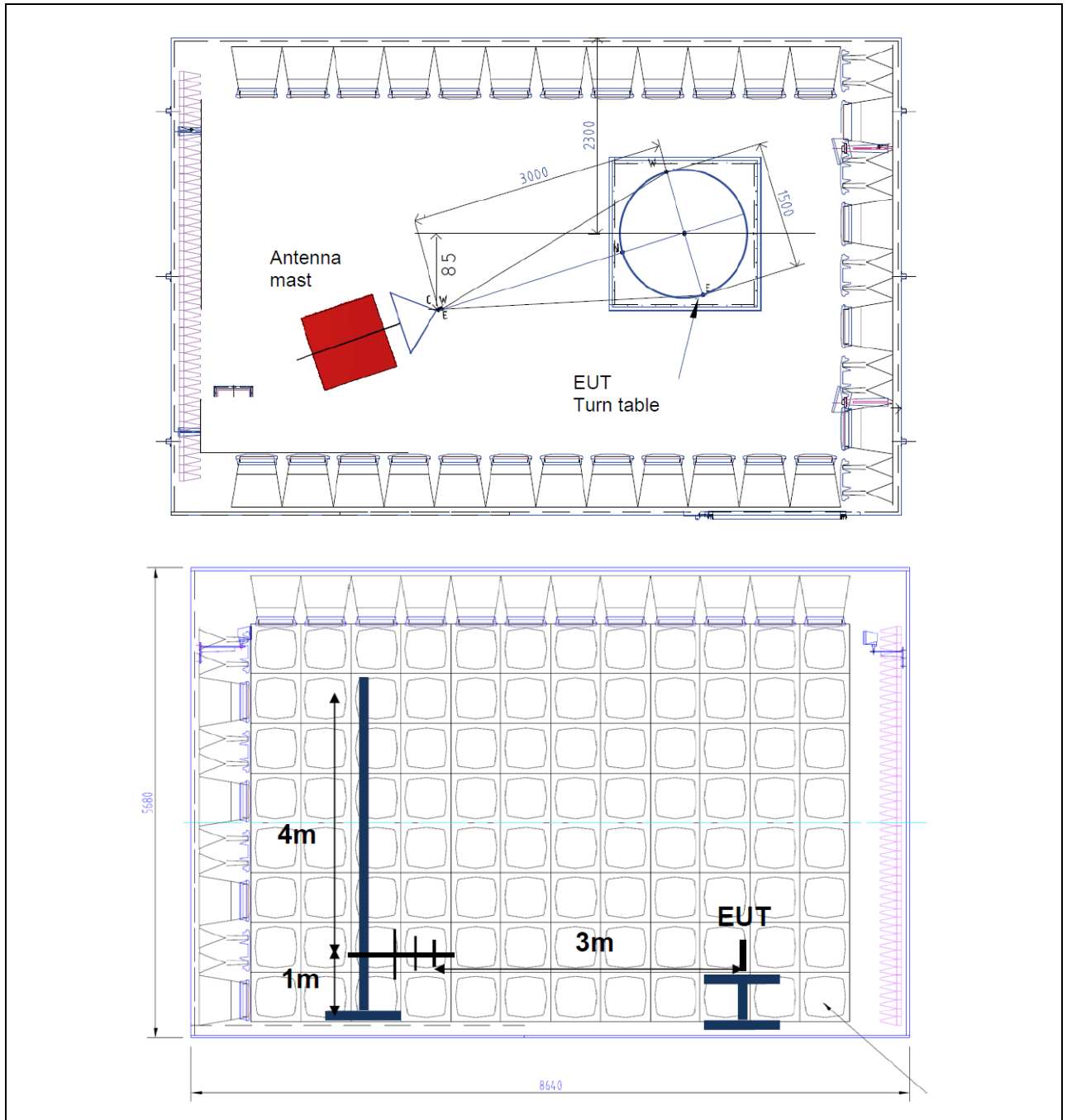

8.3 Requisiti / Requirements – Spurious Radiated Emissions and Restricted Bands of Operation

FCC Section 15.205

- (a) Except as shown in paragraph (d) of this section, only spurious emissions are permitted in any of the frequency bands listed below:

Frequency (MHz)
...
2310 - 2390
2483.5 - 2500
...

FCC Section 5.209

- (a) Except as provided elsewhere in this subpart, the emissions from an intentional radiator shall not exceed the field strength levels specified in the following table:

Frequency (MHz)	Field strength (microvolts/meter)	Measurement distance (meters)
0.009-0.490	2400/F(kHz)	300
0.490-1.705	24000/F(kHz)	30
1.705-30.0	30	30
30-88	100**	3
88-216	150**	3
216-960	200**	3
Above 960	500	3

**Except as provided in paragraph (g), fundamental emissions from intentional radiators operating under this section shall not be located in the frequency bands 54-72 MHz, 76-88 MHz, 174-216 MHz or 470-806 MHz. However, operation within these frequency bands is permitted under other sections of this part, e.g., §§15.231 and 15.241.

- (b) In the emission table above, the tighter limit applies at the band edges.
 (c) The level of any unwanted emissions from an intentional radiator operating under these general provisions shall not exceed the level of the fundamental emission. For intentional radiators which operate under the provisions of other sections within this part and which are required to reduce their unwanted emissions to the limits specified in this table, the limits in this table are based on the frequency of the unwanted emission and not the fundamental frequency. However, the level of any unwanted emissions shall not exceed the level of the fundamental frequency.
 (d) The emission limits shown in the above table are based on measurements employing a CISPR quasi-peak detector except for the frequency bands 9-90 kHz, 110-490 kHz and above 1000 MHz. Radiated emission limits in these three bands are based on measurements employing an average detector.

FCC Section 5.247

- (d) In any 100 kHz bandwidth outside the frequency band in which the spread spectrum or digitally modulated intentional radiator is operating, the radio frequency power that is produced by the intentional radiator shall be at least 20 dB below that in the 100 kHz bandwidth within the band that contains the highest level of the desired power, based on either an RF conducted or a radiated measurement, provided the transmitter demonstrates compliance with the peak conducted power limits. If the transmitter complies with the conducted power limits based on the use of RMS averaging over a time interval, as permitted under paragraph (b)(3) of this section, the attenuation required under this paragraph shall be 30 dB instead of 20 dB. Attenuation below the general limits specified in §15.209(a) is not required. In addition, radiated emissions which fall in the restricted bands, as defined in §15.205(a), must also comply with the radiated emission limits specified in §15.209(a) (see §15.205(c)).

8.4 Risultati / Results – Spurious Radiated Emissions and Restricted Bands of Operation

The result of the test is: **PASS**.

See the details in the charts/tables of the following paragraphs.

Level of maximum spurious detected:

Frequency (MHz)	Instrument Reading QP (dBµV)	Cables Correction Factors (dB)	Attenuator Correction Factor (dB)	Antenna Correction Factor (dBµV/m)	QuasiPeak (dBµV/m)	Limit (dBµV/m)	Margin (dB)	Height (cm)	Azimuth (deg)	Result
334.560000	14.7	2.4	5.9	14.0	37.0	46.0	-9.0	109.0	69.0	Pass

Frequency (MHz)	Instrument Reading CAv (dBµV)	Cables Correction Factors (dB)	Antenna Correction Factor (dBµV/m)	CAverage (dBµV/m)	Limit (dBµV/m)	Margin (dB)	Height (cm)	Azimuth (deg)	Result
1650.000000	8.6	3.9	29.0	41.5	54.0	-12.5	302.0	169.0	Pass

8.4.1 Tabelle e grafici dei risultati / Tables and graphical representation data – Spurious Radiated Emissions and Restricted Bands of Operation

8.4.1.1 Restricted Bands of Operation – Spurious Radiated Emissions and Restricted Bands of Operation

Measures executed on BLE (DTS) active on CHIP 1 (Phones)

Channel Frequency: 2402 MHz, (GFSK) Data Rate: 1Mbps

Radiated emissions measured from 2.31GHz to 2.5GHz. Average detector with IF=1MHz. FCC section 15.209 Average Limit. Vertical polarization.

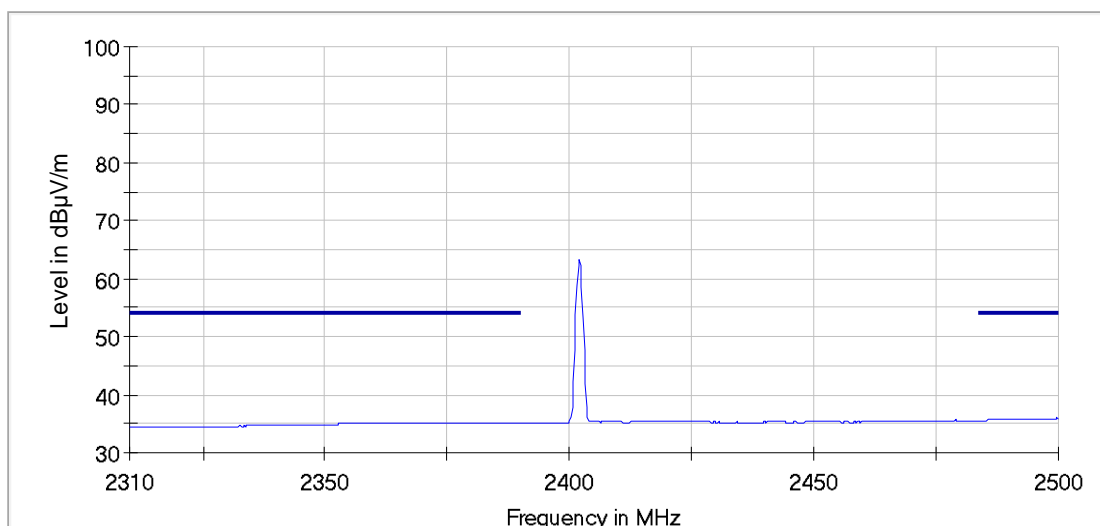

Radiated emissions measured from 2.31GHz to 2.5GHz. Average detector with IF=1MHz.
FCC section 15.209 Average Limit. Horizontal polarization.

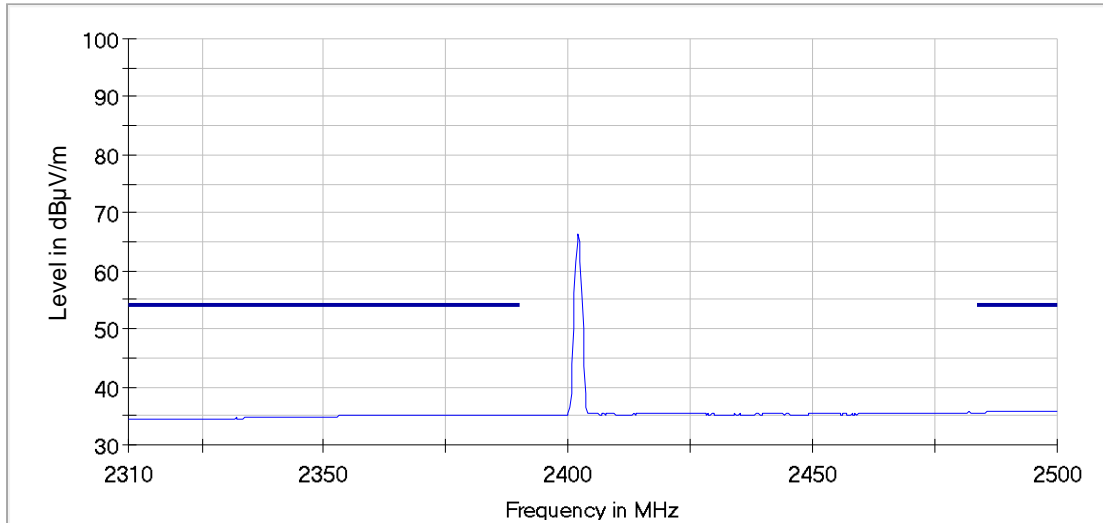

Channel Frequency: 2480 MHz, (GFSK) Data Rate: 1Mbps

Radiated emissions measured from 2.31GHz to 2.5GHz. Average detector with IF=1MHz.
FCC section 15.209 Average Limit. Vertical polarization.

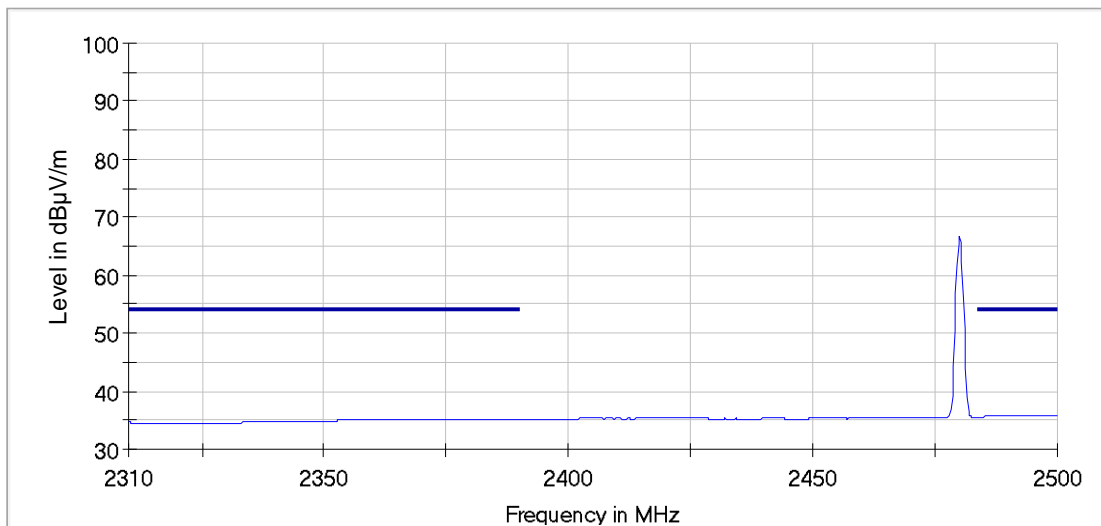

Radiated emissions measured from 2.31GHz to 2.5GHz. Average detector with IF=1MHz.

FCC section 15.209 Average Limit. Horizontal polarization.

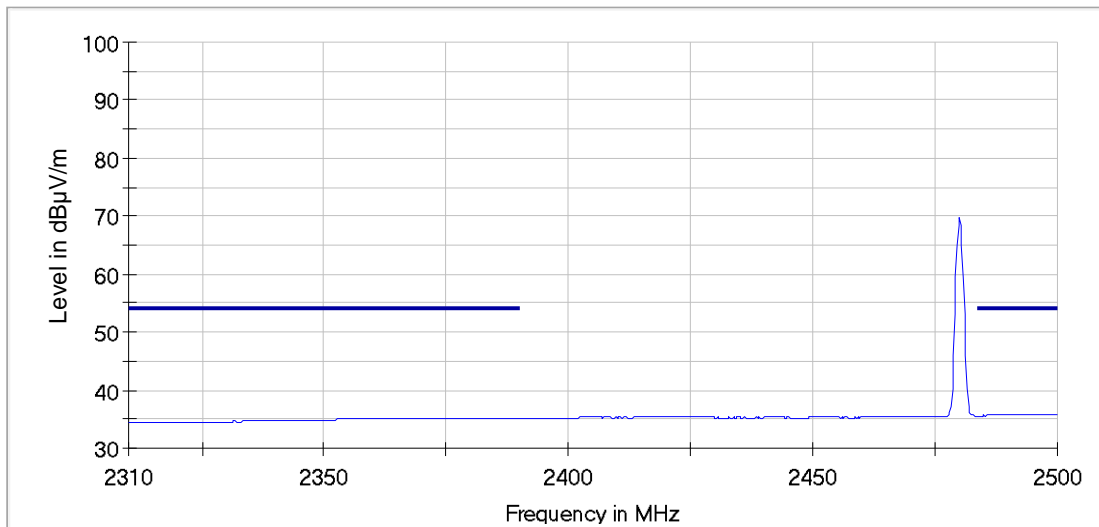

8.4.1.2 Spurious Radiated Emissions – Spurious Radiated Emissions and Restricted Bands of Operation

Measures from 9kHz to 30MHz

Noise Floor Measurements

Note: EUT switched OFF and auxiliary equipment (load box and optical converters) switched ON

Noise floor measured from 9KHz to 30MHz. Peak detector with IF=200Hz from 9kHz to 150kHz and IF=9kHz from 150kHz to 30MHz. Q-Peak/Average limit. Measuring antenna on X axis.

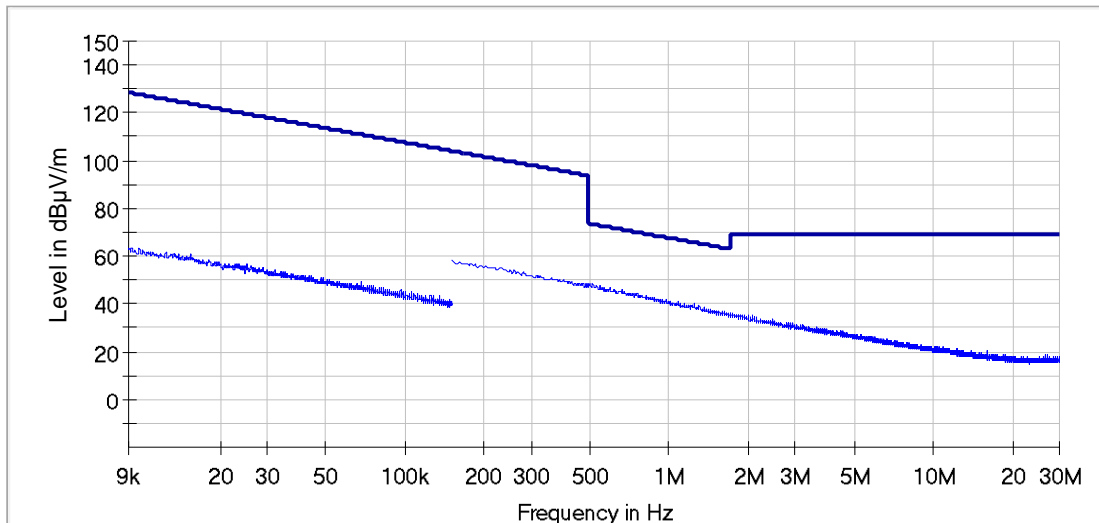

Noise floor measured from 9KHz to 30MHz. Peak detector with IF=200Hz from 9kHz to 150kHz and IF=9kHz from 150kHz to 30MHz. Q-Peak/Average limit. Measuring antenna on Y axis.

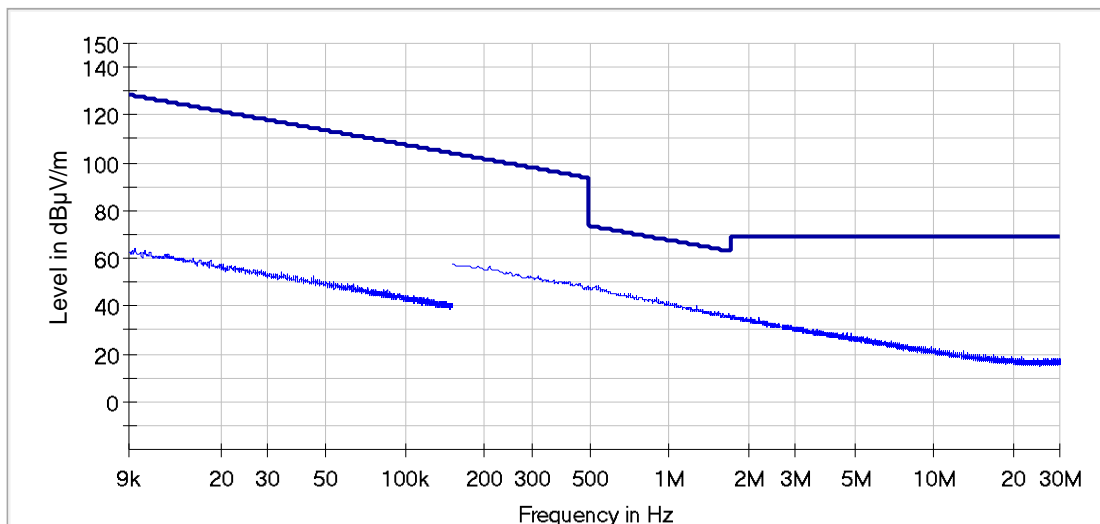

Noise floor measured from 9kHz to 30MHz. Peak detector with IF=200Hz from 9kHz to 150kHz and IF=9kHz from 150kHz to 30MHz. Q-Peak/Average limit. Measuring antenna on Z axis.

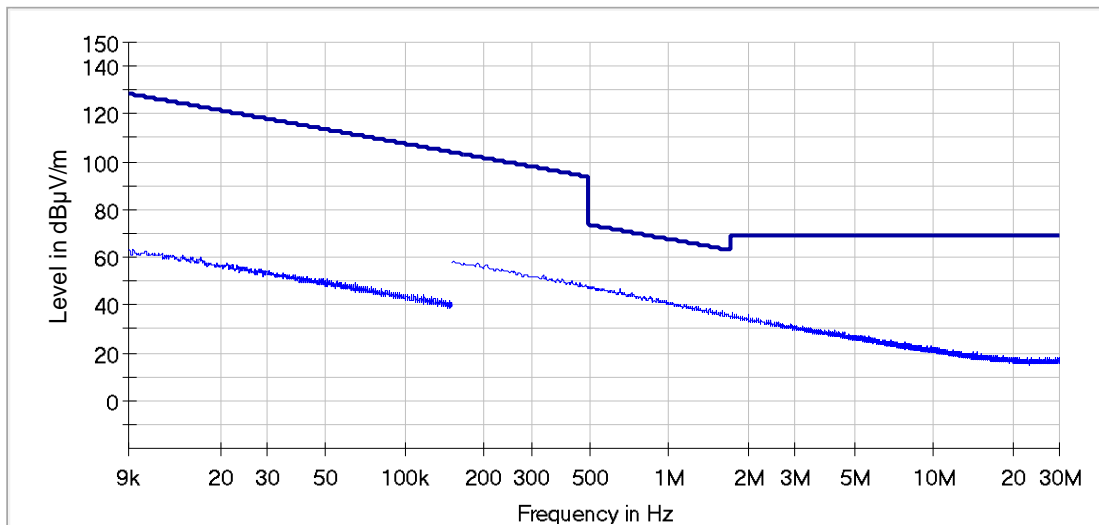

EUT Emissions Measurements

No emissions detected above noise level.

Measures from 30MHz to 1GHz

Noise Floor Measurements

Note: EUT switched OFF and auxiliary equipment (load box and optical converters) switched ON

Noise floor measured from 30MHz to 1GHz: Peak detector with IF 120kHz.
FCC section 15.209 Quasi-Peak Limit. Vertical polarization.

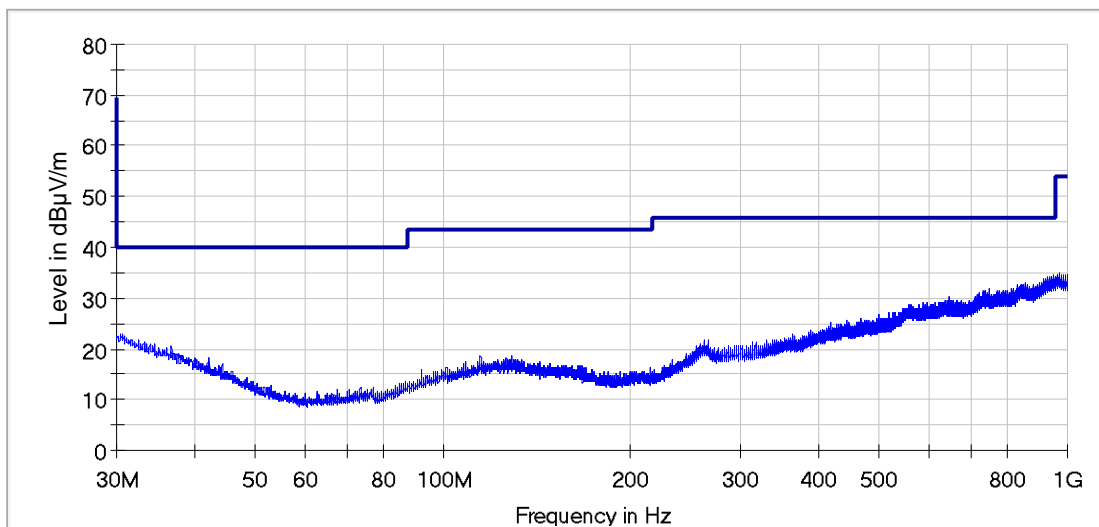

Noise floor measured from 30MHz to 1GHz: Peak detector with IF 120kHz.
FCC section 15.209 Quasi-Peak Limit. Horizontal polarization.

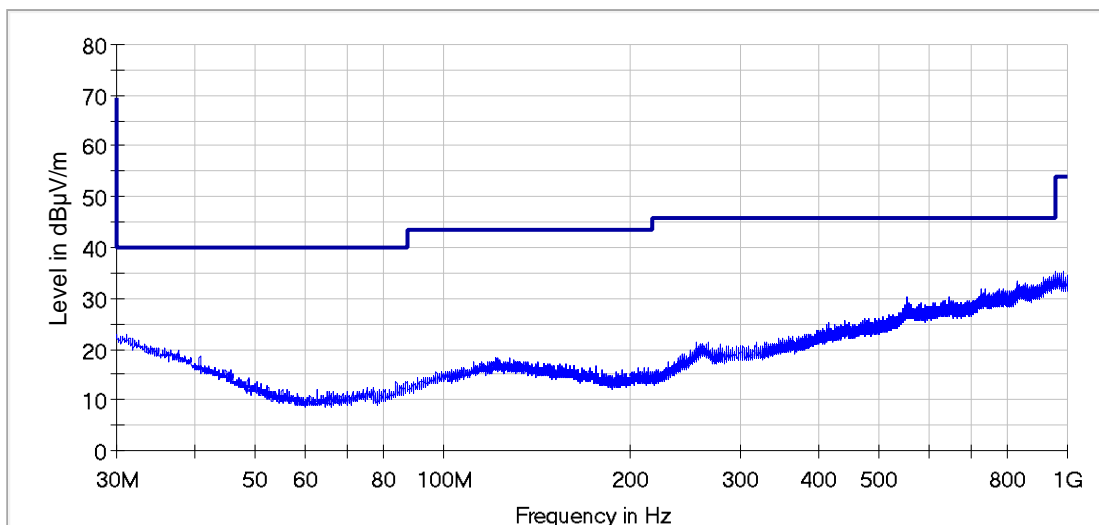

EUT Emissions Measurements

Radiated emissions measured from 30MHz to 1GHz: Peak detector with IF 120kHz.
FCC section 15.209 Quasi-Peak Limit. Vertical polarization.

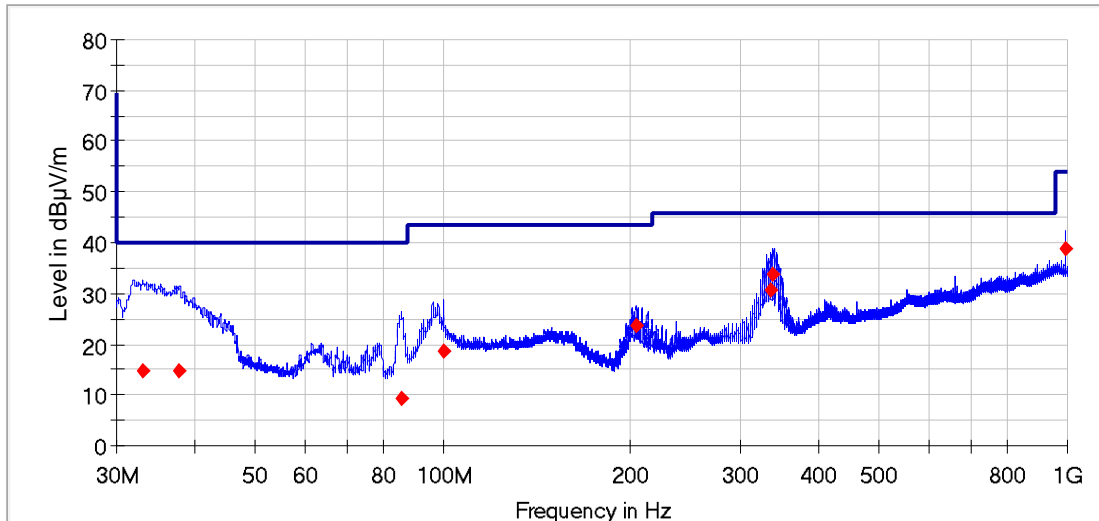

Higher signals, maximized and re-measured with quasi-peak detector

Frequency (MHz)	Instrument Reading QP (dBµV)	Cables Correction Factors (dB)	Attenuator Correction Factor (dB)	Antenna Correction Factor (dBµV/m)	QuasiPeak (dBµV/m)	Limit (dBµV/m)	Margin (dB)	Height (cm)	Azimuth (deg)	Result
33.030000	-9.2	1.1	5.9	17	14.8	40.0	-25.2	150.0	111.0	Pass
37.860000	-6.5	0.5	5.9	15	14.9	40.0	-25.1	180.0	96.0	Pass
85.620000	-6.2	1.6	5.9	8	9.3	40.0	-30.7	169.0	167.0	Pass
99.990000	1.1	1.5	5.9	10	18.5	43.5	-25.0	111.0	234.0	Pass
204.360000	6.8	2.0	5.9	9	23.7	43.5	-19.8	221.0	115.0	Pass
333.810000	8.3	2.4	5.9	14	30.6	46.0	-15.4	180.0	87.0	Pass
338.070000	11.4	2.6	5.9	14	33.9	46.0	-12.1	151.0	96.0	Pass
990.000000	3.8	3.9	5.9	25	38.6	54.0	-15.4	182.0	167.0	Pass

Radiated emissions measured from 30MHz to 1GHz: Peak detector with IF 120kHz.
FCC section 15.209 Quasi-Peak Limit. Horizontal polarization.

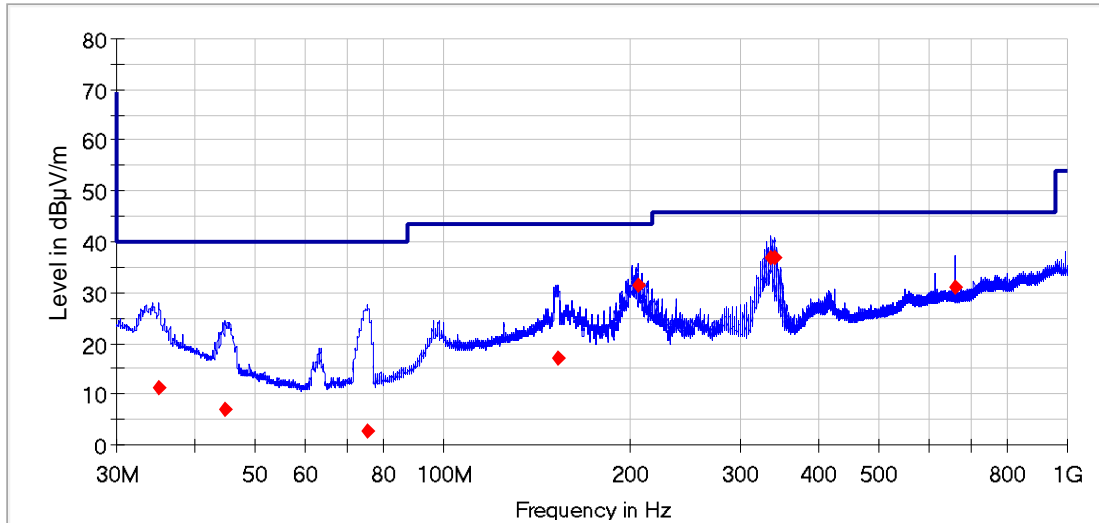

Higher signals, maximized and re-measured with quasi-peak detector

Frequency (MHz)	Instrument Reading QP (dBµV)	Cables Correction Factors (dB)	Attenuator Correction Factor (dB)	Antenna Correction Factor (dBµV/m)	QuasiPeak (dBµV/m)	Limit (dBµV/m)	Margin (dB)	Height (cm)	Azimuth (deg)	Result
35.100000	-11.6	1.0	5.9	16.0	11.3	40.0	-28.7	369.0	192.0	Pass
44.790000	-10.9	1.0	5.9	11.0	7.0	40.0	-33.0	400.0	223.0	Pass
75.780000	-10.9	0.8	5.9	7.0	2.8	40.0	-37.3	395.0	262.0	Pass
152.250000	-1.3	1.4	5.9	11.0	17.0	43.5	-26.5	228.0	192.0	Pass
204.690000	14.6	2.1	5.9	9.0	31.6	43.5	-11.9	140.0	61.0	Pass
334.560000	14.7	2.4	5.9	14.0	37.0	46.0	-9.0	109.0	69.0	Pass
338.640000	14.2	2.6	5.9	14.0	36.7	46.0	-9.3	100.0	73.0	Pass
660.000000	1.3	4.0	5.9	20.0	31.2	46.0	-14.8	129.0	177.0	Pass

Measures from 1GHz to 10GHz

Noise Floor Measurements

Note: EUT switched OFF and auxiliary equipment (load box and optical converters) switched ON

Noise floor measured from 1GHz to 10GHz: Average detector with IF 1MHz.
FCC section 15.209 Average Limit. Vertical polarization.

Note: EMI receiver internal notch filter from 2400MHz to 2483.5MHz.

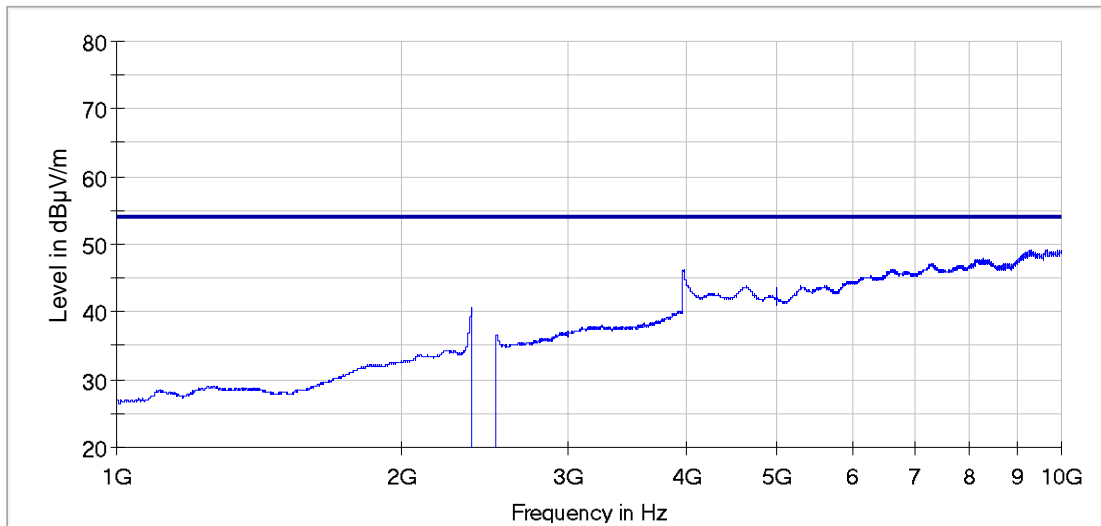

Noise floor measured from 1GHz to 10GHz: Average detector with IF 1MHz.
FCC section 15.209 Average Limit. Horizontal polarization.

Note: EMI receiver internal notch filter from 2400MHz to 2483.5MHz.

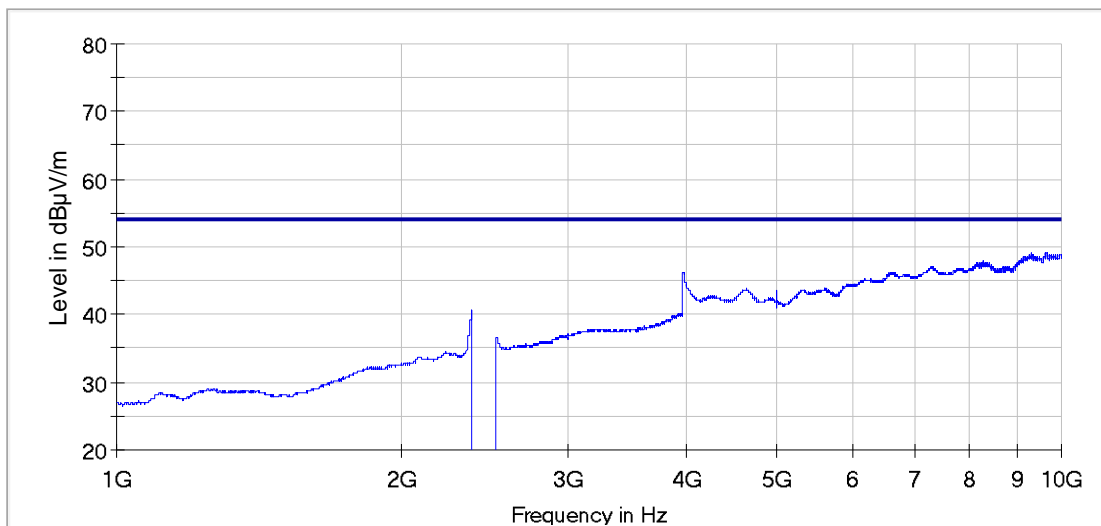

EUT Emissions Measurements

Radiated emissions measured from 1GHz to 10GHz: Average detector with IF 1MHz.
FCC section 15.209 Average Limit. Vertical polarization.

Note: EMI receiver internal notch filter from 2400MHz to 2483.5MHz.

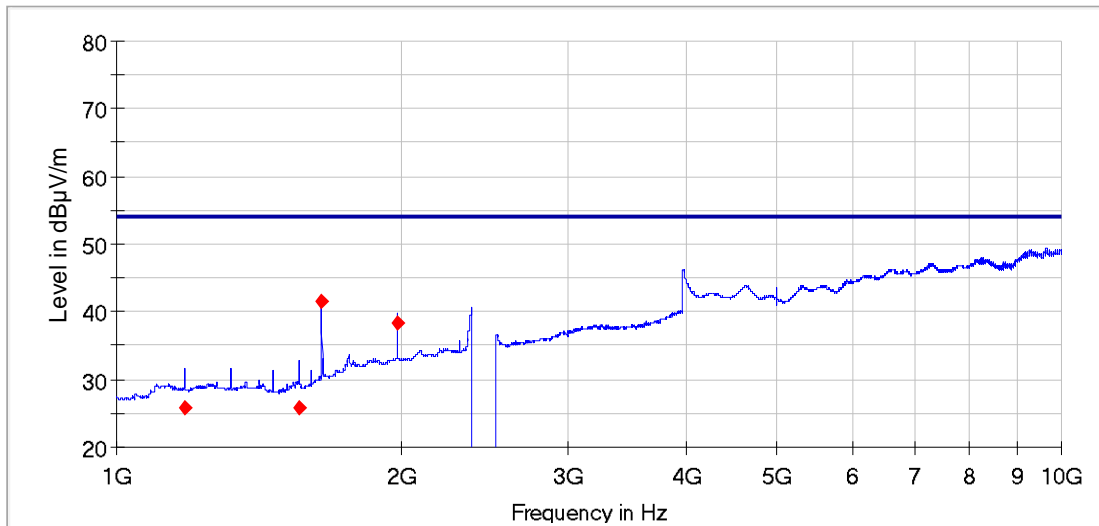

Higher signals, maximized and re-measured with CISPR-Average detector

Frequency (MHz)	Instrument Reading CAv (dBµV)	Cables Correction Factors (dB)	Antenna Correction Factor (dBµV/m)	CAverage (dBµV/m)	Limit (dBµV/m)	Margin (dB)	Height (cm)	Azimuth (deg)	Result
1181.500000	-5.8	3.6	28.0	25.8	54.0	-28.2	190.0	146.0	Pass
1559.750000	-6.1	4.0	28.0	25.9	54.0	-28.1	257.0	243.0	Pass
1650.000000	8.6	3.9	29.0	41.5	54.0	-12.5	302.0	169.0	Pass
1980.000000	2.3	4.9	31.0	38.2	54.0	-15.8	95.0	197.0	Pass

Radiated emissions measured from 1GHz to 10GHz: Average detector with IF 1MHz.
FCC section 15.209 Average Limit. Horizontal polarization.

Note: EMI receiver internal notch filter from 2400MHz to 2483.5MHz.

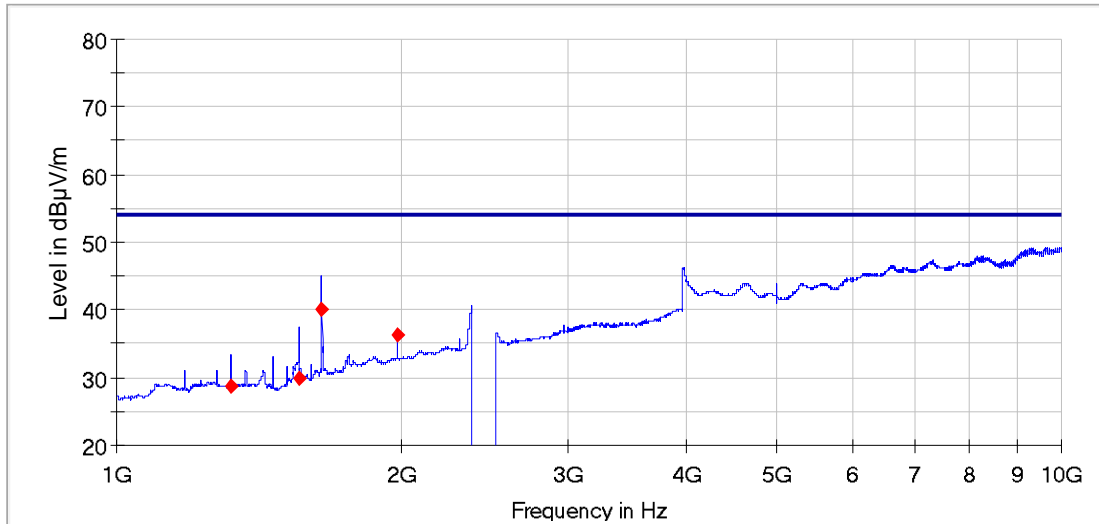

Higher signals, maximized and re-measured with CISPR-Average detector

Frequency (MHz)	Instrument Reading CAv (dBµV)	Cables Correction Factors (dB)	Antenna Correction Factor (dBµV/m)	CAverage (dBµV/m)	Limit (dBµV/m)	Margin (dB)	Height (cm)	Azimuth (deg)	Result
1320.000000	-3.8	3.4	29.0	28.6	54.0	-25.4	274.0	219.0	Pass
1559.750000	-2.0	4.0	28.0	30.0	54.0	-24.0	275.0	196.0	Pass
1650.000000	-7.3	3.9	29.0	40.2	54.0	-13.8	245.0	195.0	Pass
1980.000000	-0.3	4.9	31.0	36.2	54.0	-17.8	183.0	201.0	Pass

Measures from 10GHz to 18GHz

Noise Floor Measurements

Note: EUT switched OFF and auxiliary equipment (load box and optical converters) switched ON

Noise floor measured from 10GHz to 18GHz: Average detector with IF 1MHz.
FCC section 15.209 Average Limit. Vertical polarization.

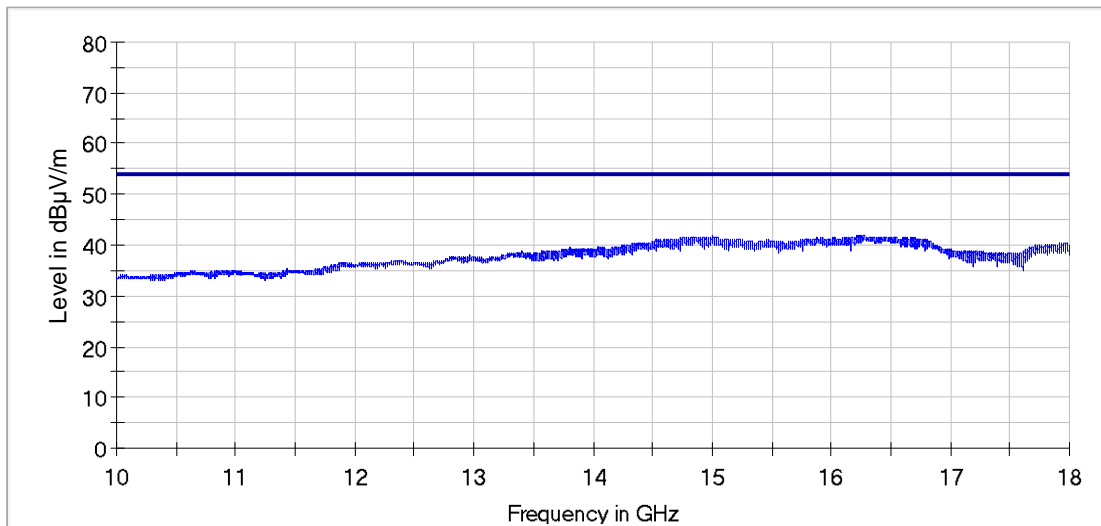

Noise floor measured from 10GHz to 18GHz: Average detector with IF 1MHz.
FCC section 15.209 Average Limit. Horizontal polarization.

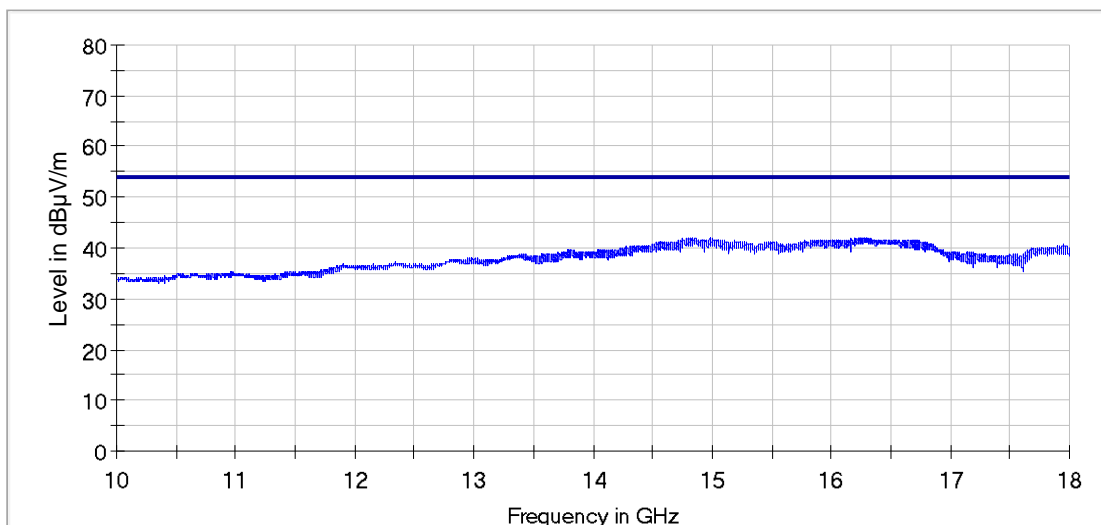

EUT Emissions Measurements

Radiated emissions measured from 10GHz to 18GHz: Average detector with IF 1MHz.
FCC section 15.209 Average Limit. Vertical polarization.

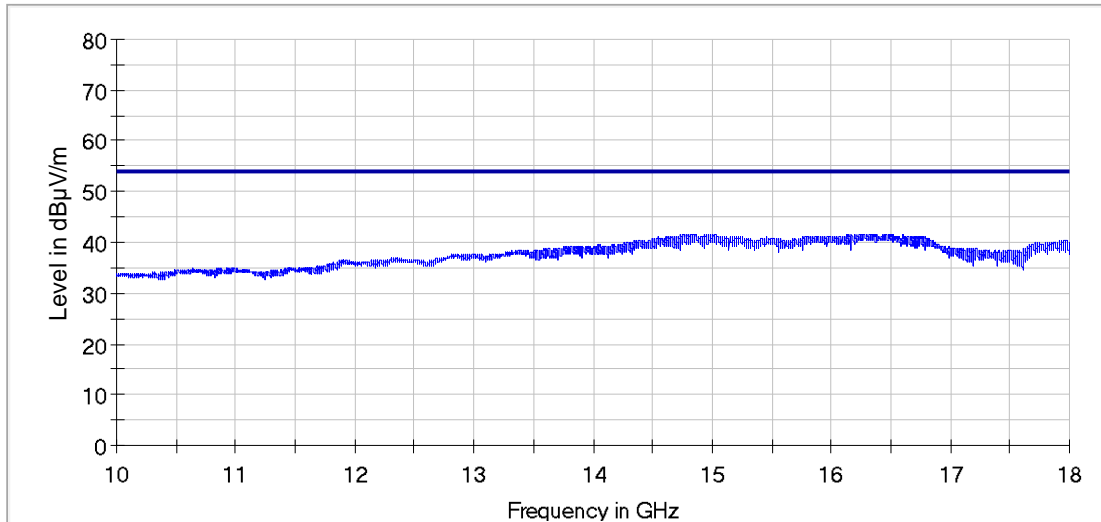

Radiated emissions measured from 10GHz to 18GHz: Average detector with IF 1MHz.
FCC section 15.209 Average Limit. Horizontal polarization.

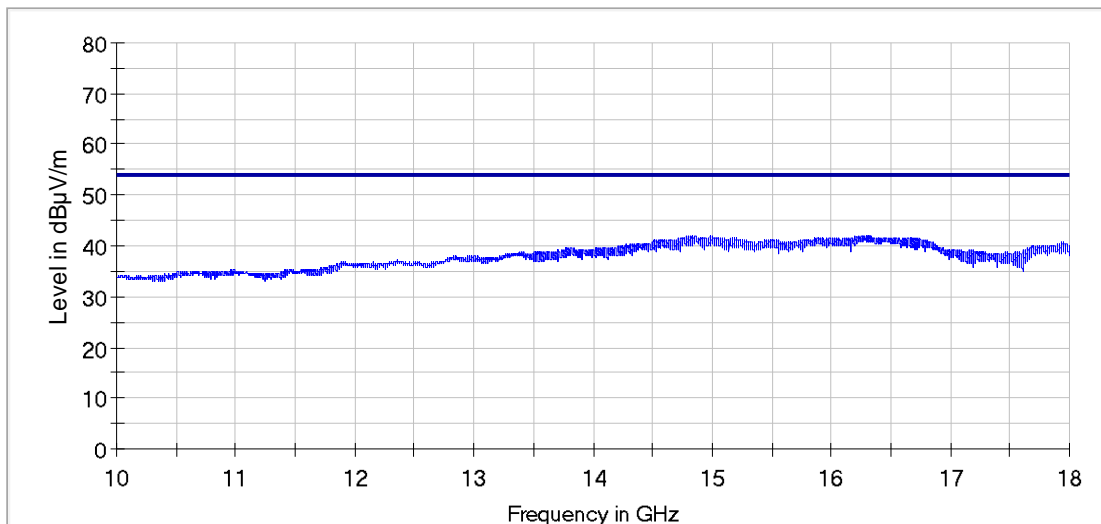

Measures from 18GHz to 25GHz

Noise Floor Measurements

Note: EUT switched OFF and auxiliary equipment (load box and optical converters) switched ON

Noise floor measured from 18GHz to 25GHz: Average detector with IF 1MHz.
FCC section 15.209 Average Limit. Vertical polarization.

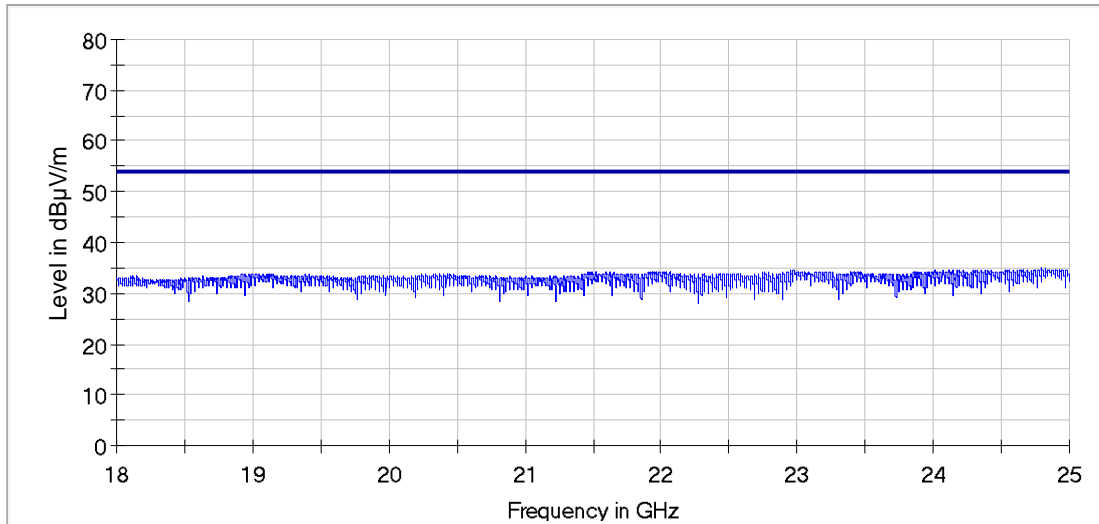

Noise floor measured from 18GHz to 25GHz: Average detector with IF 1MHz.
FCC section 15.209 Average Limit. Horizontal polarization.

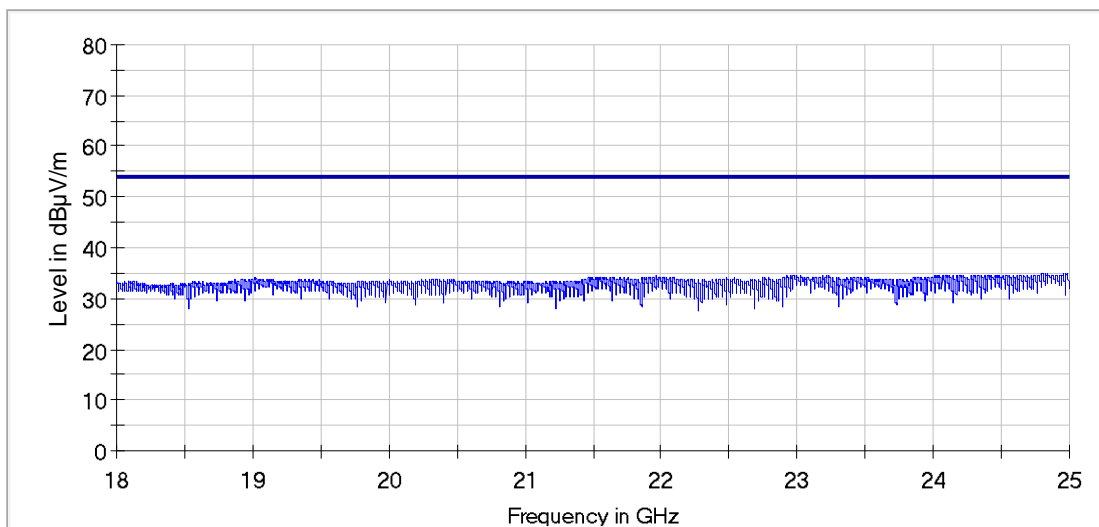

EUT Emissions Measurements

Radiated emissions measured from 18GHz to 25GHz: Average detector with IF 1MHz.
FCC section 15.209 Average Limit. Vertical polarization.

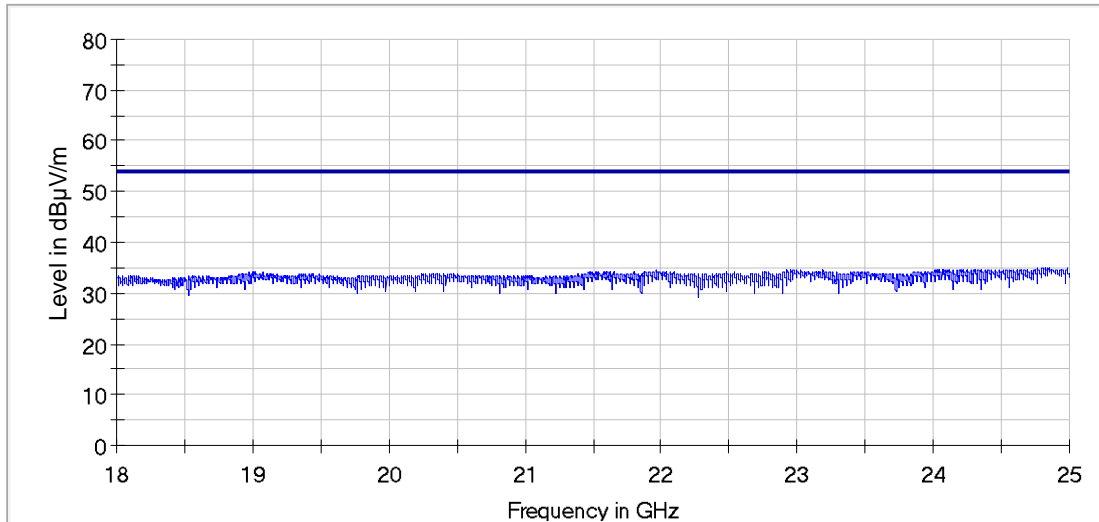

Radiated emissions measured from 18GHz to 25GHz: Average detector with IF 1MHz.
FCC section 15.209 Average Limit. Horizontal polarization.

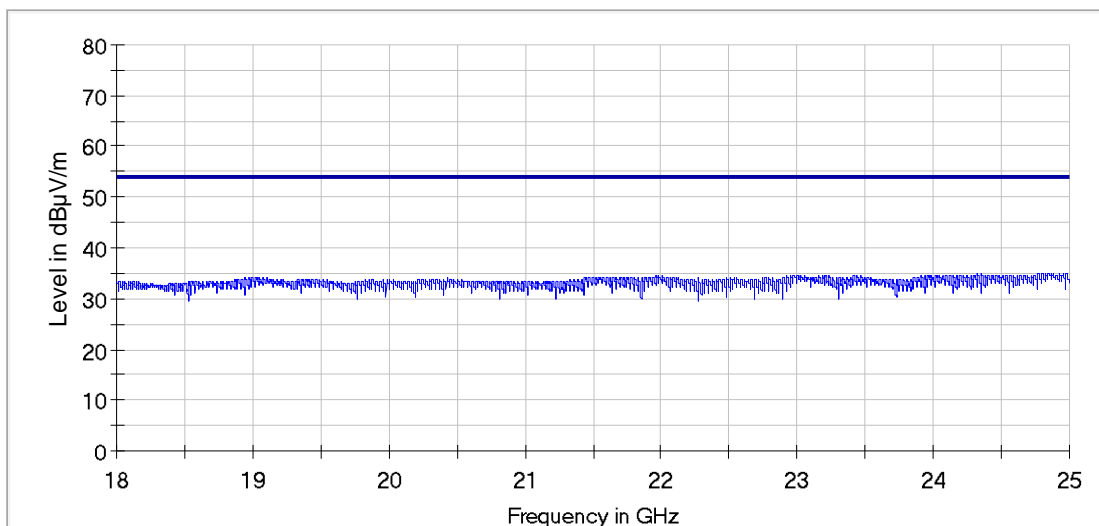

9.0 Antenna requirement – Condizioni di prova / Test Conditions

Technician / Tecnico: Loris Fruch		
Table No.	TEST: Antenna Requirement, FCC Section 15.203	\
Method	/	\
Parameters required prior to the test	Laboratory Ambient Temperature	18 to 28 °C
	Relative Humidity	20 to 90 %
Parameters recorded during the test	Laboratory Ambient Temperature	/
	Relative Humidity	/
Supplementary information: since this product has permanent integrated antennas (see par. 1.11.5 of the applicable cited Test Plan), then fulfils the requirement of this section.		

Allegato 1 / Annex 1 – Incertezza / Uncertainty

A.1.1 Measurement of Environmental parameters

Temperature: $\pm 1^{\circ}\text{C}$
RH: $\pm 4\%$

A.1.2 Radio test

Conducted output power: ± 2.1 dB

Conducted adjacent channel power: ± 1.6 dB

Conducted Bandwidth: ± 2.1 kHz (Span=3MHz, RBW=30kHz, 10000pti)

Conducted spurious emission: ± 3.7 dB

A.1.3 Radiated Spurious Emissions: FCC

From 9kHz to 30MHz using Loop antenna
Field intensity: ± 4.2 dB

From 30MHz to 200MHz using Bilog antenna
Field intensity: ± 5.5 dB

From 200MHz to 1000MHz using Bilog antenna
Field intensity: ± 4.4 dB

From 1GHz to 12GHz using Horn antenna
Field intensity: ± 5.8 dB

From 12GHz to 18GHz using Horn antenna
Field intensity: ± 5.95 dB

From 18GHz to 26GHz using Horn antenna (ANSI C63.4, ANSI C63.10)
Field intensity: ± 6.2 dB