

FCC Test Report

Report No.: RF180626C38-2

FCC ID: 2AAC6-C10

Test Model: AUT-450C

Received Date: Jun. 26, 2018

Test Date: Jul. 24, 2018 ~ Jul. 30, 2018

Issued Date: Aug. 03, 2018

Applicant: Automatic Labs, Inc.

Address: 128 KING ST, 3RD FLOOR, SAN FRANCISCO CA 94107

Issued By: Bureau Veritas Consumer Products Services (H.K.) Ltd., Taoyuan Branch

Lab Address: No. 47-2, 14th Ling, Chia Pau Vil., Lin Kou Dist., New Taipei City, Taiwan
(R.O.C)

Test Location: No.19, Hwa Ya 2nd Rd., Wen Hwa Vil., Kwei Shan Dist., Taoyuan City
33383, Taiwan, R.O.C.

**FCC Registration /
Designation Number:** 788550 / TW0003



This report is for your exclusive use. Any copying or replication of this report to or for any other person or entity, or use of our name or trademark, is permitted only with our prior written permission. This report sets forth our findings solely with respect to the test samples identified herein. The results set forth in this report are not indicative or representative of the quality or characteristics of the lot from which a test sample was taken or any similar or identical product unless specifically and expressly noted. Our report includes all of the tests requested by you and the results thereof based upon the information that you provided to us. You have 60 days from date of issuance of this report to notify us of any material error or omission caused by our negligence, provided, however, that such notice shall be in writing and shall specifically address the issue you wish to raise. A failure to raise such issue within the prescribed time shall constitute your unqualified acceptance of the completeness of this report, the tests conducted and the correctness of the report contents. Unless specific mention, the uncertainty of measurement has been explicitly taken into account to declare the compliance or non-compliance to the specification. The report must not be used by the client to claim product certification, approval, or endorsement by TAF or any government agencies.

Table of Contents

Release Control Record	4
1 Certificate of Conformity	5
2 Summary of Test Results	6
2.1 Measurement Uncertainty	6
2.2 Modification Record	6
3 General Information	7
3.1 General Description of EUT	7
3.2 Description of Test Modes	8
3.2.1 Test Mode Applicability and Tested Channel Detail	9
3.3 Duty Cycle of Test Signal	11
3.4 Description of Support Units	12
3.4.1 Configuration of System under Test	12
3.5 General Description of Applied Standards	12
4 Test Types and Results	13
4.1 Radiated Emission and Bandedge Measurement	13
4.1.1 Limits of Radiated Emission and Bandedge Measurement	13
4.1.2 Test Instruments	14
4.1.3 Test Procedures	15
4.1.4 Deviation from Test Standard	15
4.1.5 Test Set Up	16
4.1.6 EUT Operating Conditions	17
4.1.7 Test Results	18
4.2 Conducted Emission Measurement	31
4.2.1 Limits of Conducted Emission Measurement	31
4.2.2 Test Instruments	31
4.2.3 Test Procedures	32
4.2.4 Deviation from Test Standard	32
4.2.5 Test Setup	32
4.2.6 EUT Operating Conditions	32
4.2.7 Test Results	33
4.3 6 dB Bandwidth Measurement	35
4.3.1 Limits of 6 dB Bandwidth Measurement	35
4.3.2 Test Setup	35
4.3.3 Test Instruments	35
4.3.4 Test Procedure	35
4.3.5 Deviation from Test Standard	35
4.3.6 EUT Operating Conditions	35
4.3.7 Test Results	36
4.4 Occupied Bandwidth Measurement	38
4.4.1 Test Setup	38
4.4.2 Test Instruments	38
4.4.3 Test Procedure	38
4.4.4 Deviation from Test Standard	38
4.4.5 EUT Operating Conditions	38
4.4.6 Test Results	39
4.5 Conducted Output Power Measurement	41
4.5.1 Limits of Conducted Output Power Measurement	41
4.5.2 Test Setup	41
4.5.3 Test Instruments	41
4.5.4 Test Procedures	41
4.5.5 Deviation from Test Standard	41
4.5.6 EUT Operating Conditions	41
4.5.7 Test Results	42

4.6	Power Spectral Density Measurement	43
4.6.1	Limits of Power Spectral Density Measurement.....	43
4.6.2	Test Setup.....	43
4.6.3	Test Instruments	43
4.6.4	Test Procedure	43
4.6.5	Deviation from Test Standard	43
4.6.6	EUT Operating Condition	43
4.6.7	Test Results	44
4.7	Conducted Out of Band Emission Measurement	46
4.7.1	Limits of Conducted Out of Band Emission Measurement.....	46
4.7.2	Test Setup.....	46
4.7.3	Test Instruments	46
4.7.4	Test Procedure	46
4.7.5	Deviation from Test Standard	46
4.7.6	EUT Operating Condition	46
4.7.7	Test Results	47
5	Pictures of Test Arrangements.....	55
	Appendix – Information on the Testing Laboratories	56

Release Control Record

Issue No.	Description	Date Issued
RF180626C38-2	Original Release	Aug. 03, 2018

1 Certificate of Conformity

Product: OBD2 dongle

Brand: Automatic Labs

Test Model: AUT-450C

Sample Status: Production Unit

Applicant: Automatic Labs, Inc.

Test Date: Jul. 24, 2018 ~ Jul. 30, 2018

Standards: 47 CFR FCC Part 15, Subpart C (Section 15.247)
ANSI C63.10:2013

The above equipment has been tested by **Bureau Veritas Consumer Products Services (H.K.) Ltd., Taoyuan Branch**, and found compliance with the requirement of the above standards. The test record, data evaluation & Equipment Under Test (EUT) configurations represented herein are true and accurate accounts of the measurements of the sample's RF characteristics under the conditions specified in this report.

Prepared by : Evonne Liu, **Date:** Aug. 03, 2018
Evonne Liu / Specialist

Approved by : Dylan Chiou, **Date:** Aug. 03, 2018
Dylan Chiou / Project Engineer

2 Summary of Test Results

47 CFR FCC Part 15, Subpart C (Section 15.247)			
FCC Clause	Test Item	Result	Remarks
15.207	AC Power Conducted Emission	Pass	Meet the requirement of limit. Minimum passing margin is -33.56 dB at 0.61000 MHz.
15.205 / 15.209 / 15.247(d)	Radiated Emissions and Band Edge Measurement	Pass	Meet the requirement of limit. Minimum passing margin is -2.82 dB at 4824 MHz.
15.247(d)	Antenna Port Emission	Pass	Meet the requirement of limit.
15.247(a)(2)	6 dB Bandwidth	Pass	Meet the requirement of limit.
---	Occupied Bandwidth Measurement	Pass	Reference only
15.247(b)	Conducted power	Pass	Meet the requirement of limit.
15.247(e)	Power Spectral Density	Pass	Meet the requirement of limit.
15.203	Antenna Requirement	Pass	No antenna connector is used.

2.1 Measurement Uncertainty

Where relevant, the following measurement uncertainty levels have been estimated for tests performed on the EUT as specified in CISPR 16-4-2:

Measurement	Frequency	Expanded Uncertainty (k=2) (±)
Conducted Emissions at mains ports	150 kHz ~ 30 MHz	2.44 dB
Radiated Emissions up to 1 GHz	30 MHz ~ 200 MHz	2.93 dB
	200 MHz ~ 1000 MHz	2.95 dB
Radiated Emissions above 1 GHz	1 GHz ~ 18 GHz	2.26 dB
	18 GHz ~ 40 GHz	1.94 dB

2.2 Modification Record

There were no modifications required for compliance.

3 General Information

3.1 General Description of EUT

Product	OBD2 dongle
Brand	Automatic Labs
Test Model	AUT-450C
Status of EUT	Production Unit
Power Supply Rating	6~18 Vdc (DC power supply)
Modulation Type	CCK, DQPSK, DBPSK for DSSS 64QAM, 16QAM, QPSK, BPSK for OFDM
Modulation Technology	DSSS, OFDM
Transfer Rate	802.11b: 11.0 / 5.5 / 2.0 / 1.0 Mbps 802.11g: 54.0 / 48.0 / 36.0 / 24.0 / 18.0 / 12.0 / 9.0 / 6.0 Mbps 802.11n: up to 150.0 Mbps
Operating Frequency	2412 ~ 2462 MHz
Number of Channel	11 for 802.11b, 802.11g, 802.11n (HT20) 7 for 802.11n (HT40)
Output Power	116.413 mW
Antenna Type	metal antenna with 1.08 dBi gain
Antenna Connector	N/A
Accessory Device	N/A
Data Cable Supplied	N/A

Note:

1. The EUT provides 1 completed transmitter and 1 receiver.

Modulation Mode	Tx Function
802.11b	1TX
802.11g	1TX
802.11n (HT20)	1TX
802.11n (HT40)	1TX

2. The above EUT information is declared by manufacturer and for more detailed features description, please refers to the manufacturer's specifications or user's manual.

3.2 Description of Test Modes

11 channels are provided for 802.11b, 802.11g and 802.11n (HT20):

Channel	Frequency (MHz)	Channel	Frequency (MHz)
1	2412	7	2442
2	2417	8	2447
3	2422	9	2452
4	2427	10	2457
5	2432	11	2462
6	2437		

7 channels are provided for 802.11n (HT40):

Channel	Frequency (MHz)	Channel	Frequency (MHz)
3	2422	7	2442
4	2427	8	2447
5	2432	9	2452
6	2437		

3.2.1 Test Mode Applicability and Tested Channel Detail

EUT Configure Mode	Applicable To				Description
	RE \geq 1G	RE<1G	PLC	APCM	
-	√	√	√	√	-

Where **RE \geq 1G**: Radiated Emission above 1 GHz **RE<1G**: Radiated Emission below 1 GHz
PLC: Power Line Conducted Emission **APCM**: Antenna Port Conducted Measurement

NOTE: The EUT had been pre-tested on the positioned of each 3 axis. The worst case was found when positioned on **Y-plane**.

NOTE: "-" means no effect.

Radiated Emission Test (Above 1 GHz):

- Pre-Scan has been conducted to determine the worst-case mode from all possible combinations between available modulations, data rates and antenna ports (if EUT with antenna diversity architecture).
- Following channel(s) was (were) selected for the final test as listed below.

EUT Configure Mode	Mode	Available Channel	Tested Channel	Modulation Technology	Modulation Type	Data Rate (Mbps)
-	802.11b	1 to 11	1, 6, 11	DSSS	DBPSK	1.0
-	802.11g	1 to 11	1, 6, 11	OFDM	BPSK	6.0
-	802.11n (HT20)	1 to 11	1, 6, 11	OFDM	BPSK	6.5
-	802.11n (HT40)	3 to 9	3, 6, 9	OFDM	BPSK	13.5

Radiated Emission Test (Below 1 GHz):

- Pre-Scan has been conducted to determine the worst-case mode from all possible combinations between available modulations, data rates and antenna ports (if EUT with antenna diversity architecture).
- Following channel(s) was (were) selected for the final test as listed below.

EUT Configure Mode	Mode	Available Channel	Tested Channel	Modulation Technology	Modulation Type	Data Rate (Mbps)
-	802.11b	1 to 11	1	DSSS	DBPSK	1.0

Power Line Conducted Emission Test:

- Pre-Scan has been conducted to determine the worst-case mode from all possible combinations between available modulations, data rates and antenna ports (if EUT with antenna diversity architecture).
- Following channel(s) was (were) selected for the final test as listed below.

EUT Configure Mode	Mode	Available Channel	Tested Channel	Modulation Technology	Modulation Type	Data Rate (Mbps)
-	802.11b	1 to 11	1	DSSS	DBPSK	1.0

Antenna Port Conducted Measurement:

- This item includes all test value of each mode, but only includes spectrum plot of worst value of each mode.
- Pre-Scan has been conducted to determine the worst-case mode from all possible combinations between available modulations, data rates and antenna ports (if EUT with antenna diversity architecture).
- Following channel(s) was (were) selected for the final test as listed below.

EUT Configure Mode	Mode	Available Channel	Tested Channel	Modulation Technology	Modulation Type	Data Rate (Mbps)
-	802.11b	1 to 11	1, 6, 11	DSSS	DBPSK	1.0
-	802.11g	1 to 11	1, 6, 11	OFDM	BPSK	6.0
-	802.11n (HT20)	1 to 11	1, 6, 11	OFDM	BPSK	6.5
-	802.11n (HT40)	3 to 9	3, 6, 9	OFDM	BPSK	13.5

Test Condition:

Applicable To	Environmental Conditions	Input Power	Tested by
RE \geq 1G	25 deg. C, 65 % RH	120 Vac, 60 Hz	Jisyong Wang
RE<1G	25 deg. C, 65 % RH	120 Vac, 60 Hz	Jisyong Wang
PLC	25 deg. C, 65 % RH	120 Vac, 60 Hz	Thomas Wei
APCM	25 deg. C, 65 % RH	120 Vac, 60 Hz	Vincent Lin

3.3 Duty Cycle of Test Signal

Duty cycle of test signal is < 98 %, duty factor shall be considered.

802.11b: Duty cycle = $1.222/1.442 = 0.847$, Duty factor = $10 * \log(1/0.847) = 0.72$

802.11g: Duty cycle = $0.195/0.421 = 0.463$, Duty factor = $10 * \log(1/0.463) = 3.34$

802.11n (HT20): Duty cycle = $0.179/0.406 = 0.441$, Duty factor = $10 * \log(1/0.441) = 3.56$

802.11n (HT40): Duty cycle = $0.101/0.332 = 0.304$, Duty factor = $10 * \log(1/0.304) = 5.17$

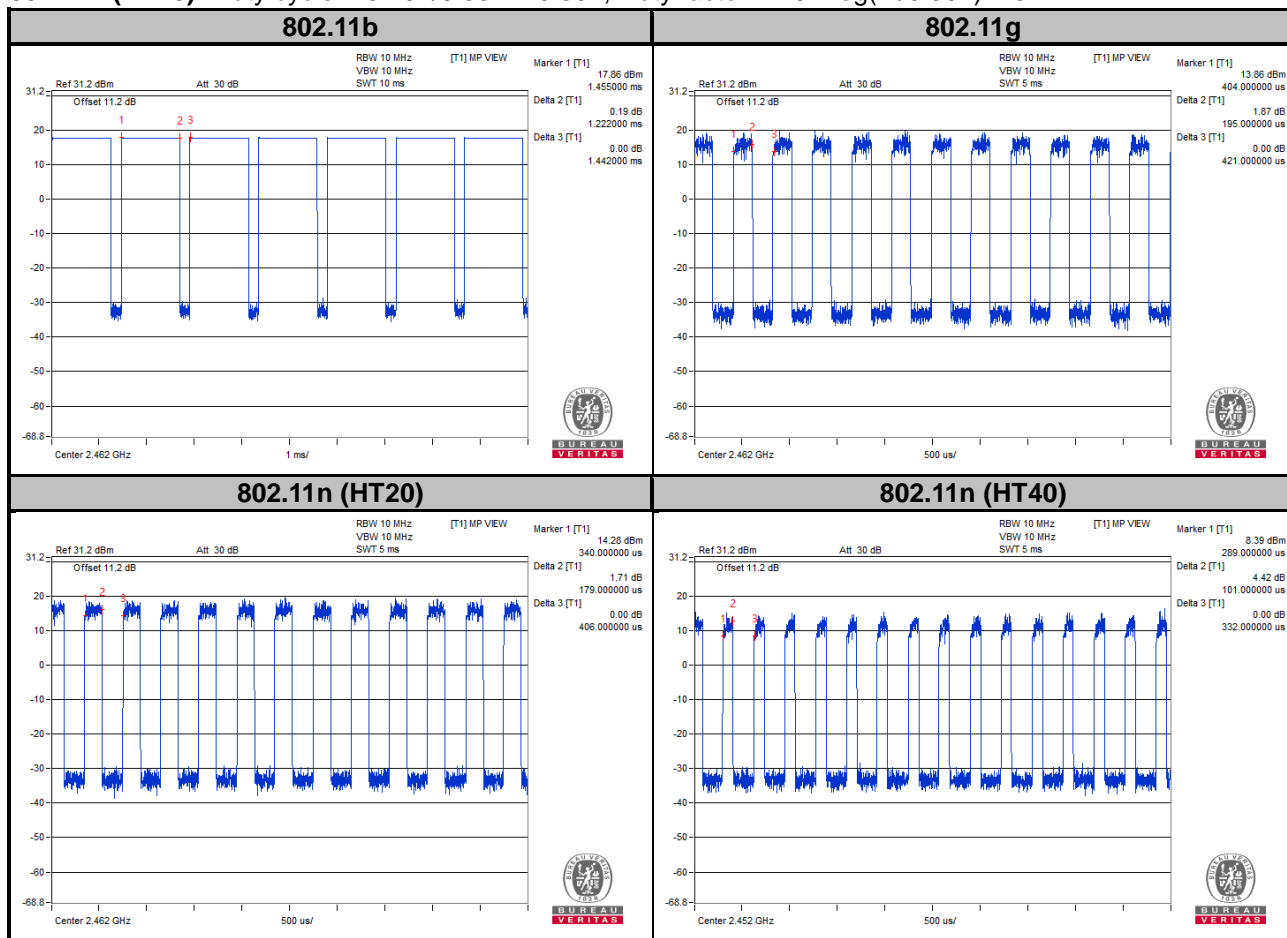

3.4 Description of Support Units

The EUT has been tested as an independent unit together with other necessary accessories or support units. The following support units or accessories were used to form a representative test configuration during the tests.

No.	Product	Brand	Model No.	Serial No.	FCC ID
1.	Battery	N/A	N/A	N/A	N/A

No.	Signal Cable Description of The Above Support Units
1.	N/A

Note:

1. All power cords of the above support units are non-shielded (1.8m).

3.4.1 Configuration of System under Test

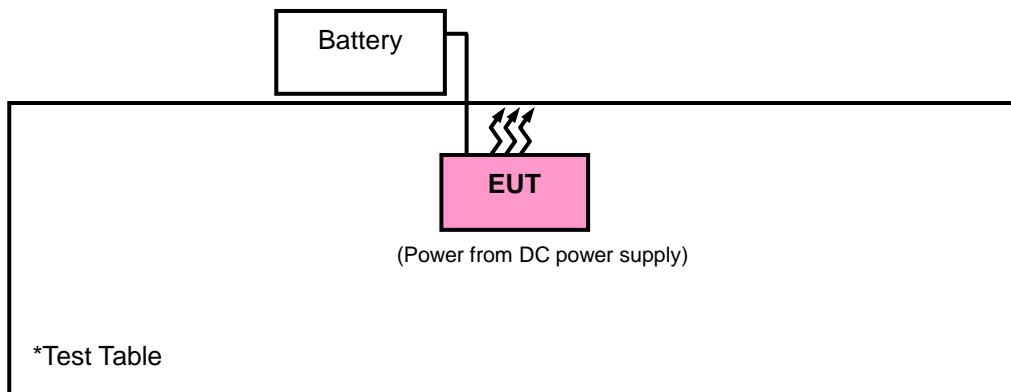

3.5 General Description of Applied Standards

The EUT is a RF Product. According to the specifications of the manufacturer, it must comply with the requirements of the following standards:

FCC Part 15, Subpart C (15.247)

KDB 558074 D01 DTS Meas Guidance v04

ANSI C63.10-2013

All test items have been performed and recorded as per the above standards.

4 Test Types and Results

4.1 Radiated Emission and Bandedge Measurement

4.1.1 Limits of Radiated Emission and Bandedge Measurement

Radiated emissions which fall in the restricted bands must comply with the radiated emission limits specified as below table. Other emissions shall be at least 20 dB below the highest level of the desired power:

Frequencies (MHz)	Field Strength (microvolts/meter)	Measurement Distance (meters)
0.009 ~ 0.490	2400/F (kHz)	300
0.490 ~ 1.705	24000/F (kHz)	30
1.705 ~ 30.0	30	30
30 ~ 88	100	3
88 ~ 216	150	3
216 ~ 960	200	3
Above 960	500	3

NOTE:

1. The lower limit shall apply at the transition frequencies.
2. Emission level (dBuV/m) = 20 log Emission level (uV/m).
3. For frequencies above 1000 MHz, the field strength limits are based on average detector, however, the peak field strength of any emission shall not exceed the maximum permitted average limits, specified above by more than 20 dB under any condition of modulation.

4.1.2 Test Instruments

Description & Manufacturer	Model No.	Serial No.	Date of Calibration	Due Date of Calibration
Test Receiver ROHDE & SCHWARZ	ESCI	100424	Oct. 17, 2017	Oct. 16, 2018
Spectrum Analyzer Agilent	N9010A	MY52220207	Dec. 07, 2017	Dec. 06, 2018
Spectrum Analyzer ROHDE & SCHWARZ	FSP40	100041	Dec. 12, 2017	Dec. 11, 2018
BILOG Antenna SCHWARZBECK	VULB9168	9168-171	Dec. 11, 2017	Dec. 10, 2018
HORN Antenna SCHWARZBECK	9120D	209	Dec. 13, 2017	Dec. 12, 2018
HORN Antenna SCHWARZBECK	BBHA 9170	BBHA9170241	Dec. 01, 2017	Nov. 30, 2018
Fixed Attenuator Mini-Circuits	BW-N4W5+	PAD-ATT4-01	Jan. 29, 2018	Jan. 28, 2019
Loop Antenna	EM-6879	269	Aug. 11, 2017	Aug. 10, 2018
Preamplifier EMCI	EMC001340	980201	Nov. 01, 2017	Oct. 31, 2018
Preamplifier EMCI	EMC 012645	980115	Oct. 20, 2017	Oct. 19, 2018
Preamplifier EMCI	EMC 184045	980116	Oct. 20, 2017	Oct. 19, 2018
Preamplifier EMCI	EMC 330H	980112	Oct. 20, 2017	Oct. 19, 2018
Power Meter Anritsu	ML2495A	1012010	Aug. 15, 2017	Aug. 14, 2018
Power Sensor Anritsu	MA2411B	1315050	Aug. 15, 2017	Aug. 14, 2018
RF Coaxial Cable	8D-FB	Cable-RF3-04	Oct. 19, 2017	Oct. 18, 2018
RF signal cable HUBER+SUHNER	SUCOFLEX 104	230129/4	Oct. 19, 2017	Oct. 18, 2018
RF signal cable HUBER+SUHNER	SUCOFLEX 104	250723/4	Oct. 19, 2017	Oct. 18, 2018
Software BV ADT	E3 6.120103	NA	NA	NA
Antenna Tower MF	MFA-440H	NA	NA	NA
Turn Table MF	MFT-201SS	NA	NA	NA
Antenna Tower & Turn Table Controller MF	MF-7802	NA	NA	NA

- Note: 1. The calibration interval of the above test instruments is 12 months and the calibrations are traceable to NML/ROC and NIST/USA.
2. The test was performed in HwaYa Chamber 10.
3. The horn antenna and preamplifier (model: EMC 184045) are used only for the measurement of emission frequency above 1 GHz if tested.
4. The IC Site Registration No. is IC7450F-10.

4.1.3 Test Procedures

For Radiated Emission below 30 MHz

- a. The EUT was placed on the top of a rotating table 0.8 meters above the ground at a 3 meter chamber room. The table was rotated 360 degrees to determine the position of the highest radiation.
- b. The EUT was set 3 meters away from the interference-receiving antenna, which was mounted on the top of a variable-height antenna tower.
- c. Parallel, perpendicular, and ground-parallel orientations of the antenna are set to make the measurement.
- d. For each suspected emission, the EUT was arranged to its worst case and the rotatable table was turned from 0 degrees to 360 degrees to find the maximum reading.
- e. The test-receiver system was set to Quasi-Peak Detect Function and Specified Bandwidth with Maximum Hold Mode.

Note:

1. The resolution bandwidth and video bandwidth of test receiver/spectrum analyzer is 9 kHz at frequency below 30 MHz.

For Radiated Emission above 30 MHz

- a. The EUT was placed on the top of a rotating table 0.8 meters (for 30 MHz ~ 1 GHz) / 1.5 meters (for above 1 GHz) above the ground at 3 meter chamber room for test. The table was rotated 360 degrees to determine the position of the highest radiation.
- b. The EUT was set 3 meters away from the interference-receiving antenna, which was mounted on the top of a variable-height antenna tower.
- c. The height of antenna is varied from one meter to four meters above the ground to determine the maximum value of the field strength. Both horizontal and vertical polarizations of the antenna are set to make the measurement.
- d. For each suspected emission, the EUT was arranged to its worst case and then the antenna was tuned to heights from 1 meter to 4 meters and the rotatable table was turned from 0 degrees to 360 degrees to find the maximum reading.
- e. The test-receiver system was set to quasi-peak detect function and specified bandwidth with maximum hold mode when the test frequency is below 1 GHz.
- f. The test-receiver system was set to peak and average detected function and specified bandwidth with maximum hold mode when the test frequency is above 1 GHz. If the peak reading value also meets average limit, measurement with the average detector is unnecessary.

Note:

1. The resolution bandwidth and video bandwidth of test receiver/spectrum analyzer is 120 kHz for Quasi-peak detection (QP) at frequency below 1 GHz.
2. The resolution bandwidth of test receiver/spectrum analyzer is 1 MHz and the video bandwidth is 3 MHz for Peak detection (PK) at frequency above 1 GHz.
3. The resolution bandwidth of test receiver/spectrum analyzer is 1 MHz and the video bandwidth is $\geq 1/T$ (Duty cycle < 98 %) or 10 Hz (Duty cycle ≥ 98 %) for Average detection (AV) at frequency above 1 GHz.
(11b: RBW = 1 MHz, VBW = 1 Hz ; 11g: RBW = 1 MHz, VBW = 10 kHz ;
11n (HT20): RBW = 1 MHz, VBW = 10 kHz ; 11n (HT40): RBW = 1 MHz, VBW = 10 kHz)
4. All modes of operation were investigated and the worst-case emissions are reported.

4.1.4 Deviation from Test Standard

No deviation.

4.1.5 Test Set Up

<Radiated Emission below 30 MHz>

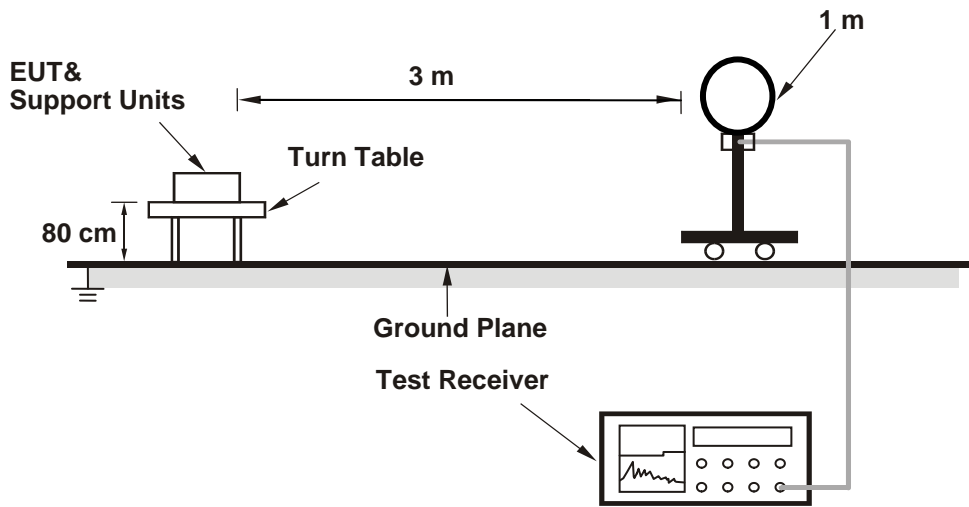

<Radiated Emission 30 MHz to 1 GHz>

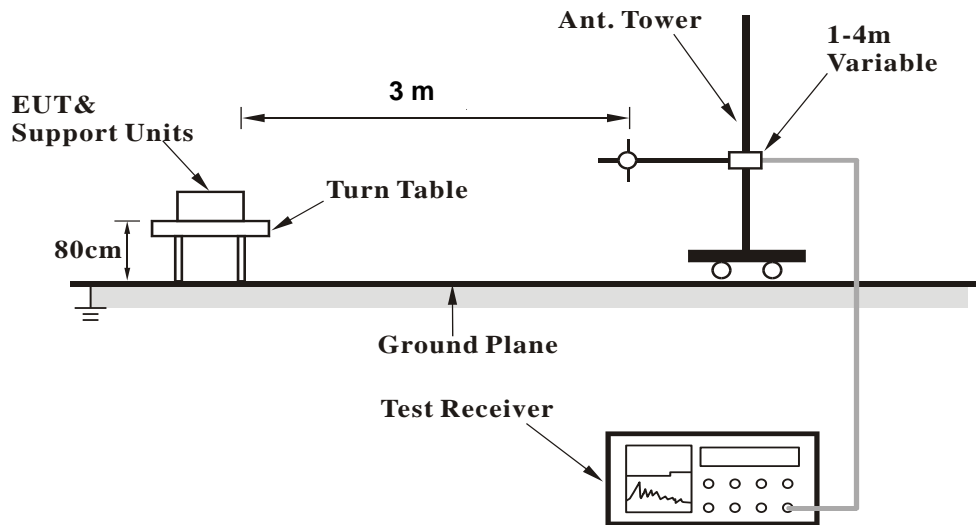

<Radiated Emission above 1 GHz>

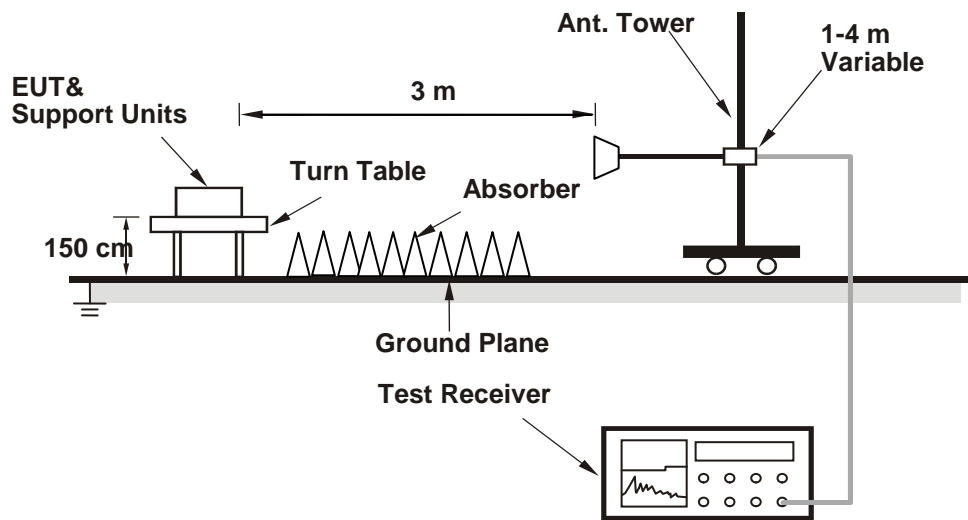

For the actual test configuration, please refer to the attached file (Test Setup Photo).

4.1.6 EUT Operating Conditions

- Placed the EUT on a testing table.
- Use the software to control the EUT under transmission condition continuously at specific channel frequency.

4.1.7 Test Results

Above 1 GHz Data :
802.11b

EUT Test Condition		Measurement Detail	
Channel	Channel 1	Frequency Range	1 GHz ~ 25 GHz
Input Power	120 Vac, 60 Hz	Detector Function	Peak (PK) Average (AV)
Environmental Conditions	25 deg. C, 65 % RH	Tested By	Jisyong Wang

Antennal Polarity & Test Distance: Horizontal at 3 m										
Frequency (MHz)	Emission Level (dBuV/m)	Read Level (dBuV)	Limit (dBuV/m)	Margin (dB)	Antenna Factor (dB/m)	Cable Loss (dB)	Preamp Factor (dB)	Antenna Height (cm)	Table Angle (Degree)	Remark
2358.58	44.09	50.25	54	-9.91	27.01	4.32	37.49	100	46	Average
2358.58	55.01	61.17	74	-18.99	27.01	4.32	37.49	100	46	Peak
2412	93.47	99.38			27.23	4.38	37.52	100	46	Average
2412	97.31	103.22			27.23	4.38	37.52	100	46	Peak
4824	51.18	66.09	54	-2.82	31.17	6.81	52.89	133	336	Average
4824	53.46	68.37	74	-20.54	31.17	6.81	52.89	133	336	Peak

Antennal Polarity & Test Distance: Vertical at 3 m										
Frequency (MHz)	Emission Level (dBuV/m)	Read Level (dBuV)	Limit (dBuV/m)	Margin (dB)	Antenna Factor (dB/m)	Cable Loss (dB)	Preamp Factor (dB)	Antenna Height (cm)	Table Angle (Degree)	Remark
2359.14	46.96	53.11	54	-7.04	27.01	4.33	37.49	163	120	Average
2359.14	58.1	64.25	74	-15.9	27.01	4.33	37.49	163	120	Peak
2412	98.01	103.92			27.23	4.38	37.52	163	120	Average
2412	101.87	107.78			27.23	4.38	37.52	163	120	Peak
4824	47.04	61.95	54	-6.96	31.17	6.81	52.89	103	248	Average
4824	49.79	64.69	74	-24.21	31.17	6.82	52.89	103	248	Peak

Remarks:

- Emission Level = Read Level + Antenna Factor + Cable Loss - Preamp Factor
Margin value = Emission level – Limit value
- 2412 MHz: Fundamental frequency.
- The emission levels of other frequencies were very low against the limit.

EUT Test Condition		Measurement Detail	
Channel	Channel 6	Frequency Range	1 GHz ~ 25 GHz
Input Power	120 Vac, 60 Hz	Detector Function	Peak (PK) Average (AV)
Environmental Conditions	25 deg. C, 65 % RH	Tested By	Jisyong Wang

Antennal Polarity & Test Distance: Horizontal at 3 m										
Frequency (MHz)	Emission Level (dBuV/m)	Read Level (dBuV)	Limit (dBuV/m)	Margin (dB)	Antenna Factor (dB/m)	Cable Loss (dB)	Preamp Factor (dB)	Antenna Height (cm)	Table Angle (Degree)	Remark
2383.78	43.04	49.11	54	-10.96	27.08	4.35	37.5	100	52	Average
2383.78	55.16	61.23	74	-18.84	27.08	4.35	37.5	100	52	Peak
2437	93.75	99.43			27.38	4.4	37.46	100	52	Average
2437	97.62	103.3			27.38	4.4	37.46	100	52	Peak
2490.28	45.41	50.69	54	-8.59	27.61	4.43	37.32	100	52	Average
2490.28	57.95	63.23	74	-16.05	27.61	4.43	37.32	100	52	Peak
4874	46.85	61.6	54	-7.15	31.25	6.86	52.86	145	332	Average
4874	49.44	64.19	74	-24.56	31.25	6.86	52.86	145	332	Peak

Antennal Polarity & Test Distance: Vertical at 3 m										
Frequency (MHz)	Emission Level (dBuV/m)	Read Level (dBuV)	Limit (dBuV/m)	Margin (dB)	Antenna Factor (dB/m)	Cable Loss (dB)	Preamp Factor (dB)	Antenna Height (cm)	Table Angle (Degree)	Remark
2383.5	47.22	53.29	54	-6.78	27.08	4.35	37.5	156	119	Average
2383.5	59.09	65.16	74	-14.91	27.08	4.35	37.5	156	119	Peak
2437	99.41	105.09			27.38	4.4	37.46	156	119	Average
2437	103.27	108.95			27.38	4.4	37.46	156	119	Peak
2490.2	47.91	53.19	54	-6.09	27.61	4.43	37.32	156	119	Average
2490.2	60.37	65.65	74	-13.63	27.61	4.43	37.32	156	119	Peak
4874	44.85	59.6	54	-9.15	31.25	6.86	52.86	110	248	Average
4874	48.41	63.16	74	-25.59	31.25	6.86	52.86	110	248	Peak

Remarks:

- Emission Level = Read Level + Antenna Factor + Cable Loss - Preamp Factor
Margin value = Emission level – Limit value
- 2437 MHz: Fundamental frequency.
- The emission levels of other frequencies were very low against the limit.

EUT Test Condition		Measurement Detail	
Channel	Channel 11	Frequency Range	1 GHz ~ 25 GHz
Input Power	120 Vac, 60 Hz	Detector Function	Peak (PK) Average (AV)
Environmental Conditions	25 deg. C, 65 % RH	Tested By	Jisyong Wang

Antennal Polarity & Test Distance: Horizontal at 3 m										
Frequency (MHz)	Emission Level (dBuV/m)	Read Level (dBuV)	Limit (dBuV/m)	Margin (dB)	Antenna Factor (dB/m)	Cable Loss (dB)	Preamp Factor (dB)	Antenna Height (cm)	Table Angle (Degree)	Remark
2462	95.64	101.16			27.46	4.41	37.39	100	53	Average
2462	99.52	105.04			27.46	4.41	37.39	100	53	Peak
2495.6	41.97	47.17	54	-12.03	27.61	4.44	37.25	100	53	Average
2495.6	54.8	60	74	-19.2	27.61	4.44	37.25	100	53	Peak
4924	47.45	62.11	54	-6.55	31.34	6.89	52.89	133	331	Average
4924	51.98	66.64	74	-22.02	31.34	6.89	52.89	133	331	Peak
Antennal Polarity & Test Distance: Vertical at 3 m										
Frequency (MHz)	Emission Level (dBuV/m)	Read Level (dBuV)	Limit (dBuV/m)	Margin (dB)	Antenna Factor (dB/m)	Cable Loss (dB)	Preamp Factor (dB)	Antenna Height (cm)	Table Angle (Degree)	Remark
2462	98.62	104.14			27.46	4.41	37.39	147	268	Average
2462	102.5	108.02			27.46	4.41	37.39	147	268	Peak
2487.48	45.74	51.1	54	-8.26	27.53	4.43	37.32	147	268	Average
2487.48	57.65	63.01	74	-16.35	27.53	4.43	37.32	147	268	Peak
4924	45.49	60.15	54	-8.51	31.34	6.89	52.89	100	250	Average
4924	50.72	65.38	74	-23.28	31.34	6.89	52.89	100	250	Peak

Remarks:

- Emission Level = Read Level + Antenna Factor + Cable Loss - Preamp Factor
Margin value = Emission level – Limit value
- 2462 MHz: Fundamental frequency.
- The emission levels of other frequencies were very low against the limit.

802.11g

EUT Test Condition		Measurement Detail	
Channel	Channel 1	Frequency Range	1 GHz ~ 25 GHz
Input Power	120 Vac, 60 Hz	Detector Function	Peak (PK) Average (AV)
Environmental Conditions	25 deg. C, 65 % RH	Tested By	Jisyong Wang

Antennal Polarity & Test Distance: Horizontal at 3 m

Frequency (MHz)	Emission Level (dBuV/m)	Read Level (dBuV)	Limit (dBuV/m)	Margin (dB)	Antenna Factor (dB/m)	Cable Loss (dB)	Preamp Factor (dB)	Antenna Height (cm)	Table Angle (Degree)	Remark
2356.9	39.76	45.92	54	-14.24	27.01	4.32	37.49	100	45	Average
2356.9	57.12	63.28	74	-16.88	27.01	4.32	37.49	100	45	Peak
2412	88.32	94.23			27.23	4.38	37.52	100	45	Average
2412	97.58	103.49			27.23	4.38	37.52	100	45	Peak
4824	33.42	48.33	54	-20.58	31.17	6.81	52.89	183	326	Average
4824	42.01	56.92	74	-31.99	31.17	6.81	52.89	183	326	Peak

Antennal Polarity & Test Distance: Vertical at 3 m

Frequency (MHz)	Emission Level (dBuV/m)	Read Level (dBuV)	Limit (dBuV/m)	Margin (dB)	Antenna Factor (dB/m)	Cable Loss (dB)	Preamp Factor (dB)	Antenna Height (cm)	Table Angle (Degree)	Remark
2362.22	41.78	47.93	54	-12.22	27.01	4.33	37.49	138	119	Average
2362.22	59.72	65.87	74	-14.28	27.01	4.33	37.49	138	119	Peak
2412	92.52	98.43			27.23	4.38	37.52	138	119	Average
2412	102	107.91			27.23	4.38	37.52	138	119	Peak
4824	32.27	47.18	54	-21.73	31.17	6.81	52.89	144	186	Average
4824	43.23	58.14	74	-30.77	31.17	6.81	52.89	144	186	Peak

Remarks:

- Emission Level = Read Level + Antenna Factor + Cable Loss - Preamp Factor
Margin value = Emission level – Limit value
- 2412 MHz: Fundamental frequency.
- The emission levels of other frequencies were very low against the limit.

EUT Test Condition		Measurement Detail	
Channel	Channel 6	Frequency Range	1 GHz ~ 25 GHz
Input Power	120 Vac, 60 Hz	Detector Function	Peak (PK) Average (AV)
Environmental Conditions	25 deg. C, 65 % RH	Tested By	Jisyong Wang

Antennal Polarity & Test Distance: Horizontal at 3 m										
Frequency (MHz)	Emission Level (dBuV/m)	Read Level (dBuV)	Limit (dBuV/m)	Margin (dB)	Antenna Factor (dB/m)	Cable Loss (dB)	Preamp Factor (dB)	Antenna Height (cm)	Table Angle (Degree)	Remark
2386.02	39.39	45.38	54	-14.61	27.16	4.35	37.5	100	51	Average
2386.02	56.35	62.34	74	-17.65	27.16	4.35	37.5	100	51	Peak
2437	88.2	93.88			27.38	4.4	37.46	100	51	Average
2437	97.73	103.41			27.38	4.4	37.46	100	51	Peak
2492.96	41.16	46.36	54	-12.84	27.61	4.44	37.25	100	51	Average
2492.96	58.99	64.19	74	-15.01	27.61	4.44	37.25	100	51	Peak
4874	32.63	47.38	54	-21.37	31.25	6.86	52.86	210	187	Average
4874	42.81	57.56	74	-31.19	31.25	6.86	52.86	210	187	Peak
Antennal Polarity & Test Distance: Vertical at 3 m										
Frequency (MHz)	Emission Level (dBuV/m)	Read Level (dBuV)	Limit (dBuV/m)	Margin (dB)	Antenna Factor (dB/m)	Cable Loss (dB)	Preamp Factor (dB)	Antenna Height (cm)	Table Angle (Degree)	Remark
2380.98	42.88	48.95	54	-11.12	27.08	4.35	37.5	156	118	Average
2380.98	61.16	67.23	74	-12.84	27.08	4.35	37.5	156	118	Peak
2437	93.78	99.46			27.38	4.4	37.46	156	118	Average
2437	103.33	109.01			27.38	4.4	37.46	156	118	Peak
2485.12	43.66	49.02	54	-10.34	27.53	4.43	37.32	156	118	Average
2485.12	62	67.36	74	-12	27.53	4.43	37.32	156	118	Peak
4874	32.79	47.54	54	-21.21	31.25	6.86	52.86	172	66	Average
4874	43.22	57.97	74	-30.78	31.25	6.86	52.86	172	66	Peak

Remarks:

- Emission Level = Read Level + Antenna Factor + Cable Loss - Preamp Factor
Margin value = Emission level – Limit value
- 2437 MHz: Fundamental frequency.
- The emission levels of other frequencies were very low against the limit.

EUT Test Condition		Measurement Detail	
Channel	Channel 11	Frequency Range	1 GHz ~ 25 GHz
Input Power	120 Vac, 60 Hz	Detector Function	Peak (PK) Average (AV)
Environmental Conditions	25 deg. C, 65 % RH	Tested By	Jisyong Wang

Antennal Polarity & Test Distance: Horizontal at 3 m										
Frequency (MHz)	Emission Level (dBuV/m)	Read Level (dBuV)	Limit (dBuV/m)	Margin (dB)	Antenna Factor (dB/m)	Cable Loss (dB)	Preamp Factor (dB)	Antenna Height (cm)	Table Angle (Degree)	Remark
2462	89.09	94.61			27.46	4.41	37.39	100	51	Average
2462	99.11	104.63			27.46	4.41	37.39	100	51	Peak
2483.64	39.65	45.01	54	-14.35	27.53	4.43	37.32	100	51	Average
2483.64	58.35	63.71	74	-15.65	27.53	4.43	37.32	100	51	Peak
4924	33.25	47.91	54	-20.75	31.34	6.89	52.89	206	159	Average
4924	43.51	58.17	74	-30.49	31.34	6.89	52.89	206	159	Peak
Antennal Polarity & Test Distance: Vertical at 3 m										
Frequency (MHz)	Emission Level (dBuV/m)	Read Level (dBuV)	Limit (dBuV/m)	Margin (dB)	Antenna Factor (dB/m)	Cable Loss (dB)	Preamp Factor (dB)	Antenna Height (cm)	Table Angle (Degree)	Remark
2462	92.18	97.7			27.46	4.41	37.39	145	268	Average
2462	101.97	107.49			27.46	4.41	37.39	145	268	Peak
2483.6	43.02	48.38	54	-10.98	27.53	4.43	37.32	145	268	Average
2483.6	63.89	69.25	74	-10.11	27.53	4.43	37.32	145	268	Peak
4924	33.46	48.12	54	-20.54	31.34	6.89	52.89	269	117	Average
4924	42.39	57.05	74	-31.61	31.34	6.89	52.89	269	117	Peak

Remarks:

- Emission Level = Read Level + Antenna Factor + Cable Loss - Preamp Factor
Margin value = Emission level – Limit value
- 2462 MHz: Fundamental frequency.
- The emission levels of other frequencies were very low against the limit.

802.11n (HT20)

EUT Test Condition		Measurement Detail	
Channel	Channel 1	Frequency Range	1 GHz ~ 25 GHz
Input Power	120 Vac, 60 Hz	Detector Function	Peak (PK) Average (AV)
Environmental Conditions	25 deg. C, 65 % RH	Tested By	Jisyong Wang

Antennal Polarity & Test Distance: Horizontal at 3 m

Frequency (MHz)	Emission Level (dBuV/m)	Read Level (dBuV)	Limit (dBuV/m)	Margin (dB)	Antenna Factor (dB/m)	Cable Loss (dB)	Preamp Factor (dB)	Antenna Height (cm)	Table Angle (Degree)	Remark
2356.2	39.46	45.62	54	-14.54	27.01	4.32	37.49	100	47	Average
2356.2	57.91	64.07	74	-16.09	27.01	4.32	37.49	100	47	Peak
2412	87.62	93.53			27.23	4.38	37.52	100	47	Average
2412	97.49	103.4			27.23	4.38	37.52	100	47	Peak
4824	32.64	47.55	54	-21.36	31.17	6.81	52.89	155	328	Average
4824	43.69	58.6	74	-30.31	31.17	6.81	52.89	155	328	Peak

Antennal Polarity & Test Distance: Vertical at 3 m

Frequency (MHz)	Emission Level (dBuV/m)	Read Level (dBuV)	Limit (dBuV/m)	Margin (dB)	Antenna Factor (dB/m)	Cable Loss (dB)	Preamp Factor (dB)	Antenna Height (cm)	Table Angle (Degree)	Remark
2358.58	41.66	47.82	54	-12.34	27.01	4.32	37.49	130	120	Average
2358.58	60.31	66.47	74	-13.69	27.01	4.32	37.49	130	120	Peak
2412	91.52	97.43			27.23	4.38	37.52	130	120	Average
2412	101.31	107.22			27.23	4.38	37.52	130	120	Peak
4824	32.38	47.29	54	-21.62	31.17	6.81	52.89	130	200	Average
4824	44.29	59.2	74	-29.71	31.17	6.81	52.89	130	200	Peak

Remarks:

- Emission Level = Read Level + Antenna Factor + Cable Loss - Preamp Factor
Margin value = Emission level – Limit value
- 2412 MHz: Fundamental frequency.
- The emission levels of other frequencies were very low against the limit.

EUT Test Condition		Measurement Detail	
Channel	Channel 6	Frequency Range	1 GHz ~ 25 GHz
Input Power	120 Vac, 60 Hz	Detector Function	Peak (PK) Average (AV)
Environmental Conditions	25 deg. C, 65 % RH	Tested By	Jisyong Wang

Antennal Polarity & Test Distance: Horizontal at 3 m										
Frequency (MHz)	Emission Level (dBuV/m)	Read Level (dBuV)	Limit (dBuV/m)	Margin (dB)	Antenna Factor (dB/m)	Cable Loss (dB)	Preamp Factor (dB)	Antenna Height (cm)	Table Angle (Degree)	Remark
2383.64	39.56	45.63	54	-14.44	27.08	4.35	37.5	100	52	Average
2383.64	56.53	62.6	74	-17.47	27.08	4.35	37.5	100	52	Peak
2437	88.14	93.82			27.38	4.4	37.46	100	52	Average
2437	97.25	102.93			27.38	4.4	37.46	100	52	Peak
2495.32	41.24	46.44	54	-12.76	27.61	4.44	37.25	100	52	Average
2495.32	59.63	64.83	74	-14.37	27.61	4.44	37.25	100	52	Peak
4877	32.88	47.63	54	-21.12	31.25	6.86	52.86	161	184	Average
4877	43.29	58.04	74	-30.71	31.25	6.86	52.86	161	184	Peak

Antennal Polarity & Test Distance: Vertical at 3 m										
Frequency (MHz)	Emission Level (dBuV/m)	Read Level (dBuV)	Limit (dBuV/m)	Margin (dB)	Antenna Factor (dB/m)	Cable Loss (dB)	Preamp Factor (dB)	Antenna Height (cm)	Table Angle (Degree)	Remark
2383.92	41.94	48.01	54	-12.06	27.08	4.35	37.5	125	118	Average
2383.92	60.8	66.87	74	-13.2	27.08	4.35	37.5	125	118	Peak
2437	93.2	98.88			27.38	4.4	37.46	125	118	Average
2437	102.83	108.51			27.38	4.4	37.46	125	118	Peak
2486.44	43.32	48.68	54	-10.68	27.53	4.43	37.32	125	118	Average
2486.44	62	67.36	74	-12	27.53	4.43	37.32	125	118	Peak
4874	33.09	47.84	54	-20.91	31.25	6.86	52.86	149	247	Average
4874	43.24	57.99	74	-30.76	31.25	6.86	52.86	149	247	Peak

Remarks:

- Emission Level = Read Level + Antenna Factor + Cable Loss - Preamp Factor
Margin value = Emission level – Limit value
- 2437 MHz: Fundamental frequency.
- The emission levels of other frequencies were very low against the limit.

EUT Test Condition		Measurement Detail	
Channel	Channel 11	Frequency Range	1 GHz ~ 25 GHz
Input Power	120 Vac, 60 Hz	Detector Function	Peak (PK) Average (AV)
Environmental Conditions	25 deg. C, 65 % RH	Tested By	Jisyong Wang

Antennal Polarity & Test Distance: Horizontal at 3 m										
Frequency (MHz)	Emission Level (dBuV/m)	Read Level (dBuV)	Limit (dBuV/m)	Margin (dB)	Antenna Factor (dB/m)	Cable Loss (dB)	Preamp Factor (dB)	Antenna Height (cm)	Table Angle (Degree)	Remark
2462	89.22	94.74			27.46	4.41	37.39	100	51	Average
2462	99.43	104.95			27.46	4.41	37.39	100	51	Peak
2483.76	40.63	45.99	54	-13.37	27.53	4.43	37.32	100	51	Average
2483.76	60.56	65.92	74	-13.44	27.53	4.43	37.32	100	51	Peak
4924	32.53	47.19	54	-21.47	31.34	6.89	52.89	118	37	Average
4924	44.84	59.5	74	-29.16	31.34	6.89	52.89	118	37	Peak
Antennal Polarity & Test Distance: Vertical at 3 m										
Frequency (MHz)	Emission Level (dBuV/m)	Read Level (dBuV)	Limit (dBuV/m)	Margin (dB)	Antenna Factor (dB/m)	Cable Loss (dB)	Preamp Factor (dB)	Antenna Height (cm)	Table Angle (Degree)	Remark
2462	92.03	97.55			27.46	4.41	37.39	145	267	Average
2462	101.85	107.37			27.46	4.41	37.39	145	267	Peak
2483.6	43.85	49.21	54	-10.15	27.53	4.43	37.32	145	267	Average
2483.6	67.8	73.16	74	-6.2	27.53	4.43	37.32	145	267	Peak
4924	32.86	47.52	54	-21.14	31.34	6.89	52.89	133	329	Average
4924	45.4	60.06	74	-28.6	31.34	6.89	52.89	133	329	Peak

Remarks:

- Emission Level = Read Level + Antenna Factor + Cable Loss - Preamp Factor
Margin value = Emission level – Limit value
- 2462 MHz: Fundamental frequency.
- The emission levels of other frequencies were very low against the limit.

802.11n (HT40)

EUT Test Condition		Measurement Detail	
Channel	Channel 3	Frequency Range	1 GHz ~ 25 GHz
Input Power	120 Vac, 60 Hz	Detector Function	Peak (PK) Average (AV)
Environmental Conditions	25 deg. C, 65 % RH	Tested By	Jisyoung Wang

Antennal Polarity & Test Distance: Horizontal at 3 m										
Frequency (MHz)	Emission Level (dBuV/m)	Read Level (dBuV)	Limit (dBuV/m)	Margin (dB)	Antenna Factor (dB/m)	Cable Loss (dB)	Preamp Factor (dB)	Antenna Height (cm)	Table Angle (Degree)	Remark
2389.94	42.3	48.3	54	-11.7	27.16	4.36	37.52	100	46	Average
2389.94	61.51	67.51	74	-12.49	27.16	4.36	37.52	100	46	Peak
2422	84.03	89.79			27.31	4.39	37.46	100	46	Average
2422	93.5	99.26			27.31	4.39	37.46	100	46	Peak
2483.6	39.75	45.11	54	-14.25	27.53	4.43	37.32	100	46	Average
2483.6	57.47	62.83	74	-16.53	27.53	4.43	37.32	100	46	Peak
4844	33.34	48.19	54	-20.66	31.2	6.83	52.88	147	49	Average
4844	43.78	58.63	74	-30.22	31.2	6.83	52.88	147	49	Peak
Antennal Polarity & Test Distance: Vertical at 3 m										
Frequency (MHz)	Emission Level (dBuV/m)	Read Level (dBuV)	Limit (dBuV/m)	Margin (dB)	Antenna Factor (dB/m)	Cable Loss (dB)	Preamp Factor (dB)	Antenna Height (cm)	Table Angle (Degree)	Remark
2389.94	43.67	49.67	54	-10.33	27.16	4.36	37.52	161	119	Average
2389.94	62.85	68.85	74	-11.15	27.16	4.36	37.52	161	119	Peak
2422	88.83	94.59			27.31	4.39	37.46	161	119	Average
2422	98.27	104.03			27.31	4.39	37.46	161	119	Peak
2485.72	41.94	47.3	54	-12.06	27.53	4.43	37.32	161	119	Average
2485.72	59.58	64.94	74	-14.42	27.53	4.43	37.32	161	119	Peak
4844	33.7	48.55	54	-20.3	31.2	6.83	52.88	122	207	Average
4844	43.69	58.54	74	-30.31	31.2	6.83	52.88	122	207	Peak

Remarks:

- Emission Level = Read Level + Antenna Factor + Cable Loss - Preamp Factor
Margin value = Emission level – Limit value
- 2422 MHz: Fundamental frequency.
- The emission levels of other frequencies were very low against the limit.

EUT Test Condition		Measurement Detail	
Channel	Channel 6	Frequency Range	1 GHz ~ 25 GHz
Input Power	120 Vac, 60 Hz	Detector Function	Peak (PK) Average (AV)
Environmental Conditions	25 deg. C, 65 % RH	Tested By	Jisyoung Wang

Antennal Polarity & Test Distance: Horizontal at 3 m										
Frequency (MHz)	Emission Level (dBuV/m)	Read Level (dBuV)	Limit (dBuV/m)	Margin (dB)	Antenna Factor (dB/m)	Cable Loss (dB)	Preamp Factor (dB)	Antenna Height (cm)	Table Angle (Degree)	Remark
2388.82	41.17	47.15	54	-12.83	27.16	4.36	37.5	100	52	Average
2388.82	57.81	63.79	74	-16.19	27.16	4.36	37.5	100	52	Peak
2437	85.78	91.46			27.38	4.4	37.46	100	52	Average
2437	95.11	100.79			27.38	4.4	37.46	100	52	Peak
2483.6	42.42	47.78	54	-11.58	27.53	4.43	37.32	100	52	Average
2483.6	60.1	65.46	74	-13.9	27.53	4.43	37.32	100	52	Peak
4874	33.31	48.06	54	-20.69	31.25	6.86	52.86	155	319	Average
4874	44.86	59.61	74	-29.14	31.25	6.86	52.86	155	319	Peak
Antennal Polarity & Test Distance: Vertical at 3 m										
Frequency (MHz)	Emission Level (dBuV/m)	Read Level (dBuV)	Limit (dBuV/m)	Margin (dB)	Antenna Factor (dB/m)	Cable Loss (dB)	Preamp Factor (dB)	Antenna Height (cm)	Table Angle (Degree)	Remark
2389.24	43.75	49.73	54	-10.25	27.16	4.36	37.5	124	118	Average
2389.24	61.61	67.59	74	-12.39	27.16	4.36	37.5	124	118	Peak
2437	91.08	96.76			27.38	4.4	37.46	124	118	Average
2437	100.28	105.96			27.38	4.4	37.46	124	118	Peak
2483.6	45.93	51.29	54	-8.07	27.53	4.43	37.32	124	118	Average
2483.6	62.76	68.12	74	-11.24	27.53	4.43	37.32	124	118	Peak
4874	33.62	48.37	54	-20.38	31.25	6.86	52.86	163	219	Average
4874	43	57.75	74	-31	31.25	6.86	52.86	163	219	Peak

Remarks:

- Emission Level = Read Level + Antenna Factor + Cable Loss - Preamp Factor
Margin value = Emission level – Limit value
- 2437 MHz: Fundamental frequency.
- The emission levels of other frequencies were very low against the limit.

EUT Test Condition		Measurement Detail	
Channel	Channel 9	Frequency Range	1 GHz ~ 25 GHz
Input Power	120 Vac, 60 Hz	Detector Function	Peak (PK) Average (AV)
Environmental Conditions	25 deg. C, 65 % RH	Tested By	Jisyong Wang

Antennal Polarity & Test Distance: Horizontal at 3 m										
Frequency (MHz)	Emission Level (dBuV/m)	Read Level (dBuV)	Limit (dBuV/m)	Margin (dB)	Antenna Factor (dB/m)	Cable Loss (dB)	Preamp Factor (dB)	Antenna Height (cm)	Table Angle (Degree)	Remark
2389.94	38.18	44.18	54	-15.82	27.16	4.36	37.52	100	52	Average
2389.94	55.16	61.16	74	-18.84	27.16	4.36	37.52	100	52	Peak
2452	84.59	90.19			27.38	4.41	37.39	100	52	Average
2452	93.64	99.24			27.38	4.41	37.39	100	52	Peak
2483.68	41.11	46.47	54	-12.89	27.53	4.43	37.32	100	52	Average
2483.68	58.48	63.84	74	-15.52	27.53	4.43	37.32	100	52	Peak
4904	33.21	47.87	54	-20.79	31.31	6.88	52.85	142	81	Average
4904	44.88	59.54	74	-29.12	31.31	6.88	52.85	142	81	Peak
Antennal Polarity & Test Distance: Vertical at 3 m										
Frequency (MHz)	Emission Level (dBuV/m)	Read Level (dBuV)	Limit (dBuV/m)	Margin (dB)	Antenna Factor (dB/m)	Cable Loss (dB)	Preamp Factor (dB)	Antenna Height (cm)	Table Angle (Degree)	Remark
2387.7	40.94	46.92	54	-13.06	27.16	4.36	37.5	148	269	Average
2387.7	58.86	64.84	74	-15.14	27.16	4.36	37.5	148	269	Peak
2452	87.8	93.4			27.38	4.41	37.39	148	269	Average
2452	97.24	102.84			27.38	4.41	37.39	148	269	Peak
2483.52	44.89	50.25	54	-9.11	27.53	4.43	37.32	148	269	Average
2483.52	65.52	70.88	74	-8.48	27.53	4.43	37.32	148	269	Peak
4904	33.45	48.11	54	-20.55	31.31	6.88	52.85	122	233	Average
4904	43.74	58.4	74	-30.26	31.31	6.88	52.85	122	233	Peak

Remarks:

1. Emission Level = Read Level + Antenna Factor + Cable Loss - Preamp Factor
Margin value = Emission level – Limit value
2. 2452 MHz: Fundamental frequency.
3. The emission levels of other frequencies were very low against the limit.

9 kHz ~ 30 MHz Data:

The amplitude of spurious emissions attenuated more than 20 dB below the permissible value is not required to be report.

30 MHz ~ 1 GHz Worst-Case Data:

802.11b

EUT Test Condition		Measurement Detail	
Channel	Channel 1	Frequency Range	30 MHz ~ 1 GHz
Input Power	120 Vac, 60 Hz	Detector Function	Peak (PK) Quasi-peak (QP)
Environmental Conditions	25 deg. C, 65 % RH	Tested By	Jisyong Wang

Antennal Polarity & Test Distance: Horizontal at 3 m										
Frequency (MHz)	Emission Level (dBuV/m)	Read Level (dBuV)	Limit (dBuV/m)	Margin (dB)	Antenna Factor (dB/m)	Cable Loss (dB)	Preamp Factor (dB)	Antenna Height (cm)	Table Angle (Degree)	Remark
44.55	30.27	47.3	40	-9.73	13.6	0.51	31.14	165	231	Peak
54.25	23.27	41.49	40	-16.73	12.56	0.55	31.33	111	152	Peak
224	22.23	42.27	46	-23.77	10.38	1.35	31.77	205	265	Peak
456.8	20.54	33.76	46	-25.46	16.46	2.31	31.99	111	132	Peak
887.48	28.15	32.81	46	-17.85	23.35	3.98	31.99	185	147	Peak
932.1	28.9	33.02	46	-17.1	23.69	4.17	31.98	165	259	Peak
Antennal Polarity & Test Distance: Vertical at 3 m										
Frequency (MHz)	Emission Level (dBuV/m)	Read Level (dBuV)	Limit (dBuV/m)	Margin (dB)	Antenna Factor (dB/m)	Cable Loss (dB)	Preamp Factor (dB)	Antenna Height (cm)	Table Angle (Degree)	Remark
43.58	29.82	46.84	40	-10.18	13.59	0.5	31.11	111	165	Peak
53.28	23.89	42.01	40	-16.11	12.66	0.55	31.33	205	231	Peak
112.45	22.47	43.26	43.5	-21.03	10.27	0.8	31.86	165	295	Peak
216.24	17.25	37.55	46	-28.75	10.05	1.31	31.66	111	132	Peak
645.95	24.11	32.91	46	-21.89	20.16	3.09	32.05	285	265	Peak
895.24	28.53	33.08	46	-17.47	23.45	4	32	111	147	Peak

Remarks:

- Emission Level = Read Level + Antenna Factor + Cable Loss - Preamp Factor
Margin value = Emission level – Limit value.
- The emission levels of other frequencies were very low against the limit.

4.2 Conducted Emission Measurement

4.2.1 Limits of Conducted Emission Measurement

Frequency (MHz)	Conducted Limit (dBuV)	
	Quasi-Peak	Average
0.15 - 0.5	66 - 56	56 - 46
0.50 - 5.0	56	46
5.0 - 30.0	60	50

- Note: 1. The lower limit shall apply at the transition frequencies.
 2. The limit decreases in line with the logarithm of the frequency in the range of 0.15 to 0.50 MHz.

4.2.2 Test Instruments

Description & Manufacturer	Model No.	Serial No.	Date of Calibration	Due Date of Calibration
Test Receiver ROHDE & SCHWARZ	ESCI	100613	Nov. 23, 2017	Nov. 22, 2018
RF signal cable Woken	5D-FB	Cable-cond1-01	Sep. 05, 2017	Sep. 04, 2018
LISN/AMN ROHDE & SCHWARZ (EUT)	ENV216	101826	Feb. 26, 2018	Feb. 25, 2019
LISN/AMN ROHDE & SCHWARZ (Peripheral)	ESH3-Z5	100311	Aug. 15, 2017	Aug. 14, 2018
Software ADT	BV ADT_Cond_ V7.3.7.4	NA	NA	NA

- Note: 1. The calibration interval of the above test instruments is 12 months and the calibrations are traceable to NML/ROC and NIST/USA.
 2. The test was performed in HwaYa Shielded Room 1.
 3. The VCCI Site Registration No. is C-2040.

4.2.3 Test Procedures

- a. The EUT was placed 0.4 meters from the conducting wall of the shielded room with EUT being connected to the power mains through a line impedance stabilization network (LISN). Other support units were connected to the power mains through another LISN. The two LISNs provide 50 ohm/50 uH of coupling impedance for the measuring instrument.
- b. Both lines of the power mains connected to the EUT were checked for maximum conducted interference.
- c. The frequency range from 150 kHz to 30 MHz was searched. Emission levels under (Limit – 20 dB) was not recorded.

Note: The resolution bandwidth and video bandwidth of test receiver is 9 kHz for quasi-peak detection (QP) and average detection (AV) at frequency 0.15 MHz – 30 MHz.

4.2.4 Deviation from Test Standard

No deviation.

4.2.5 Test Setup

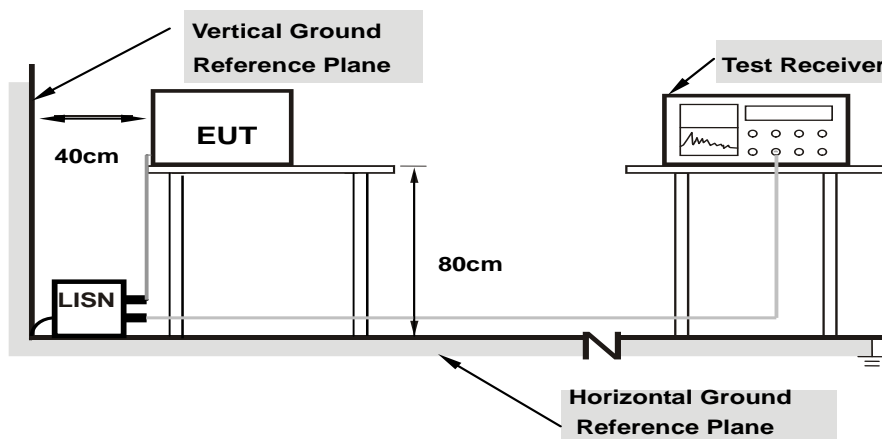

Note: 1.Support units were connected to second LISN.

For the actual test configuration, please refer to the attached file (Test Setup Photo).

4.2.6 EUT Operating Conditions

- a. Placed the EUT on a testing table.
- b. Use the software to control the EUT under transmission condition continuously at specific channel frequency.

4.2.7 Test Results

Frequency Range	150kHz ~ 30MHz	Detector Function & Resolution Bandwidth	Quasi-Peak (QP) / Average (AV), 9kHz
Input Power	120Vac, 60Hz	Environmental Conditions	25°C, 65%RH
Tested by	Thomas Wei	Test Date	2018/7/30

Phase Of Power : Line (L)										
No	Frequency (MHz)	Correction Factor (dB)	Reading Value (dBuV)		Emission Level (dBuV)		Limit (dBuV)		Margin (dB)	
			Q.P.	AV.	Q.P.	AV.	Q.P.	AV.	Q.P.	AV.
1	0.16200	9.67	10.91	-12.31	20.58	-2.64	65.36	55.36	-44.78	-58.00
2	0.32600	9.67	9.74	-11.14	19.41	-1.47	59.55	49.55	-40.14	-51.02
3	0.61000	9.67	12.77	-12.38	22.44	-2.71	56.00	46.00	-33.56	-48.71
4	6.65000	9.81	15.20	-13.42	25.01	-3.61	60.00	50.00	-34.99	-53.61
5	10.09800	9.87	13.85	-14.41	23.72	-4.54	60.00	50.00	-36.28	-54.54
6	20.39800	9.95	10.55	-1.75	20.50	8.20	60.00	50.00	-39.50	-41.80

Remarks:

1. Q.P. and AV. are abbreviations of quasi-peak and average individually.
2. The emission levels of other frequencies were very low against the limit.
3. Margin value = Emission level – Limit value
4. Correction factor = Insertion loss + Cable loss
5. Emission Level = Correction Factor + Reading Value

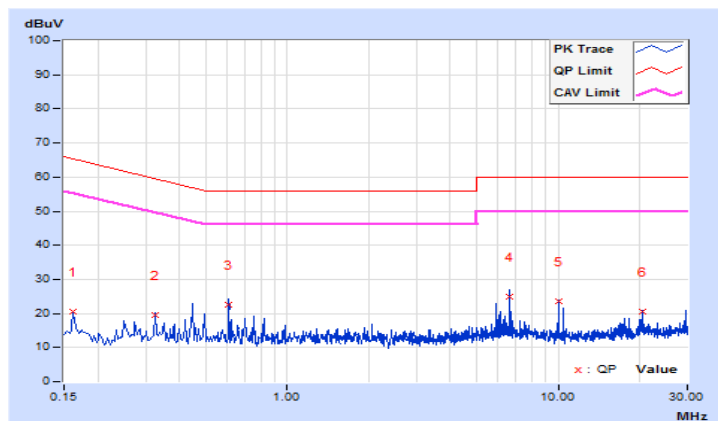

Frequency Range	150kHz ~ 30MHz	Detector Function & Resolution Bandwidth	Quasi-Peak (QP) / Average (AV), 9kHz
Input Power	120Vac, 60Hz	Environmental Conditions	25°C, 65%RH
Tested by	Thomas Wei	Test Date	2018/7/30

Phase Of Power : Neutral (N)										
No	Frequency (MHz)	Correction Factor (dB)	Reading Value (dBuV)		Emission Level (dBuV)		Limit (dBuV)		Margin (dB)	
			Q.P.	AV.	Q.P.	AV.	Q.P.	AV.	Q.P.	AV.
1	0.15800	9.68	15.66	-12.18	25.34	-2.50	65.57	55.57	-40.23	-58.07
2	0.29800	9.68	11.67	-13.09	21.35	-3.41	60.30	50.30	-38.95	-53.71
3	0.51800	9.68	12.46	-13.24	22.14	-3.56	56.00	46.00	-33.86	-49.56
4	0.70609	9.68	9.43	-10.14	19.11	-0.46	56.00	46.00	-36.89	-46.46
5	5.00600	9.78	12.72	-14.49	22.50	-4.71	60.00	50.00	-37.50	-54.71
6	7.51800	9.83	13.39	-14.23	23.22	-4.40	60.00	50.00	-36.78	-54.40

Remarks:

1. Q.P. and AV. are abbreviations of quasi-peak and average individually.
2. The emission levels of other frequencies were very low against the limit.
3. Margin value = Emission level – Limit value
4. Correction factor = Insertion loss + Cable loss
5. Emission Level = Correction Factor + Reading Value

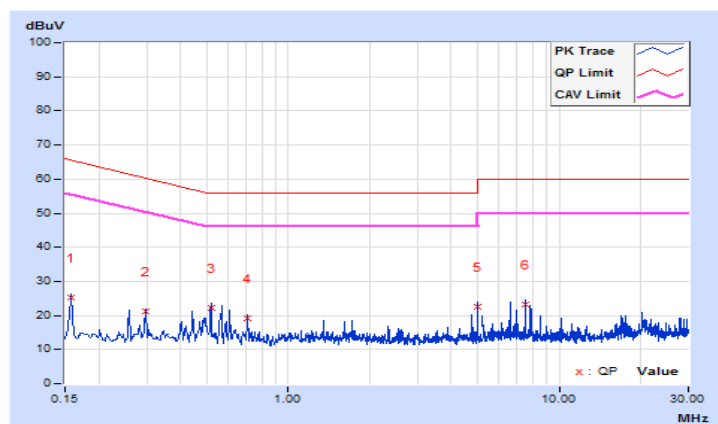

4.3 6 dB Bandwidth Measurement

4.3.1 Limits of 6 dB Bandwidth Measurement

The minimum of 6 dB Bandwidth Measurement is 0.5 MHz.

4.3.2 Test Setup

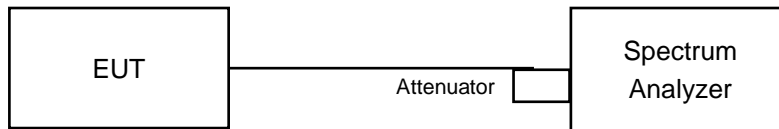

4.3.3 Test Instruments

Refer to section 4.1.2 to get information of above instrument.

4.3.4 Test Procedure

- a. Set resolution bandwidth (RBW) = 100 kHz
- b. Set the video bandwidth (VBW) $\geq 3 \times$ RBW, Detector = Peak.
- c. Trace mode = max hold.
- d. Sweep = auto couple.
- e. Measure the maximum width of the emission that is constrained by the frequencies associated with the two amplitude points (upper and lower) that are attenuated by 6 dB relative to the maximum level measured in the fundamental emission

4.3.5 Deviation from Test Standard

No deviation.

4.3.6 EUT Operating Conditions

The software provided by client to enable the EUT under transmission condition continuously at lowest, middle and highest channel frequencies individually.

4.3.7 Test Results

802.11b

Channel	Frequency (MHz)	6 dB Bandwidth (MHz)	Minimum Limit (MHz)	Pass / Fail
1	2412	10.05	0.5	Pass
6	2437	10.11	0.5	Pass
11	2462	10.11	0.5	Pass

802.11g

Channel	Frequency (MHz)	6 dB Bandwidth (MHz)	Minimum Limit (MHz)	Pass / Fail
1	2412	15.16	0.5	Pass
6	2437	15.16	0.5	Pass
11	2462	15.16	0.5	Pass

802.11n (HT20)

Channel	Frequency (MHz)	6 dB Bandwidth (MHz)	Minimum Limit (MHz)	Pass / Fail
1	2412	15.15	0.5	Pass
6	2437	15.15	0.5	Pass
11	2462	15.16	0.5	Pass

802.11n (HT40)

Channel	Frequency (MHz)	6 dB Bandwidth (MHz)	Minimum Limit (MHz)	Pass / Fail
3	2422	33.88	0.5	Pass
6	2437	33.95	0.5	Pass
9	2452	33.95	0.5	Pass

Spectrum Plot of Worst Value

802.11b

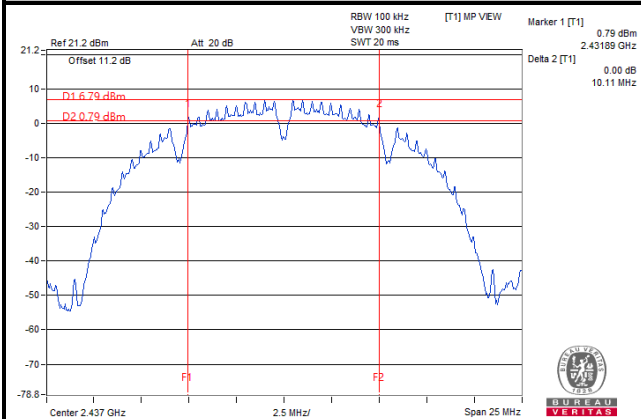

802.11g

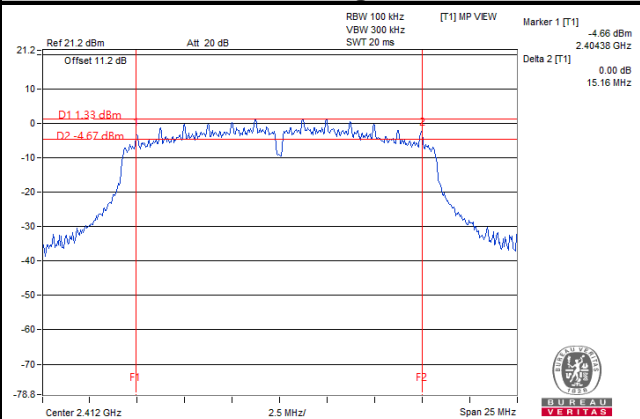

802.11n (HT20)

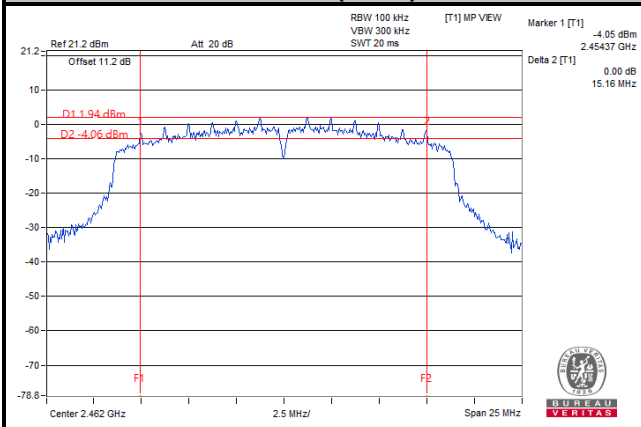

802.11n (HT40)

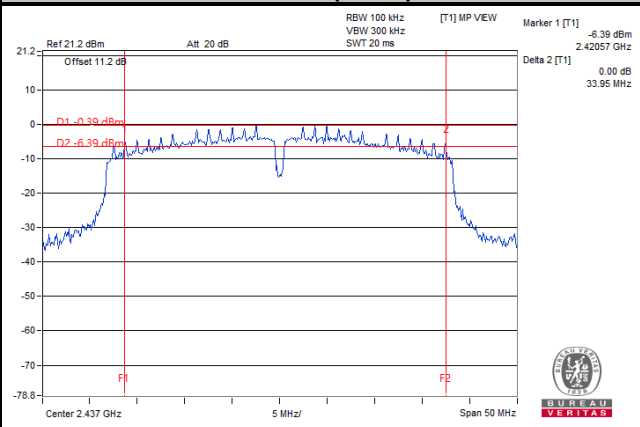

4.4 Occupied Bandwidth Measurement

4.4.1 Test Setup

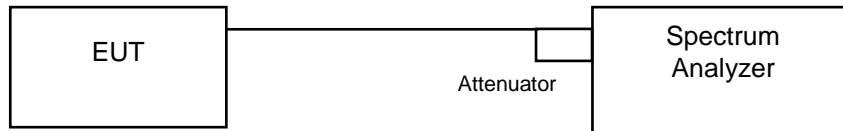

4.4.2 Test Instruments

Refer to section 4.1.2 to get information of above instrument.

4.4.3 Test Procedure

The transmitter output was connected to the spectrum analyzer through an attenuator. The bandwidth of the fundamental frequency was measured by spectrum analyzer with resolution bandwidth in the range of 1 % to 5 % of the anticipated emission bandwidth, and a video bandwidth at least 3x the resolution bandwidth and set the detector to PEAK. The width of a frequency band such that, below the lower and above the upper frequency limits, the mean powers emitted are each equal to a specified percentage 0.5 % of the total mean power of a given emission.

4.4.4 Deviation from Test Standard

No deviation.

4.4.5 EUT Operating Conditions

The software provided by client to enable the EUT under transmission condition continuously at lowest, middle and highest channel frequencies individually.

4.4.6 Test Results

802.11b

Channel	Frequency (MHz)	Occupied Bandwidth (MHz)	Pass / Fail
1	2412	14.70	Pass
6	2437	14.52	Pass
11	2462	14.52	Pass

802.11g

Channel	Frequency (MHz)	Occupied Bandwidth (MHz)	Pass / Fail
1	2412	16.44	Pass
6	2437	17.16	Pass
11	2462	16.32	Pass

802.11n (HT20)

Channel	Frequency (MHz)	Occupied Bandwidth (MHz)	Pass / Fail
1	2412	17.52	Pass
6	2437	17.76	Pass
11	2462	17.52	Pass

802.11n (HT40)

Channel	Frequency (MHz)	Occupied Bandwidth (MHz)	Pass / Fail
3	2422	35.76	Pass
6	2437	36.12	Pass
9	2452	35.88	Pass

Spectrum Plot of Worst Value

802.11b

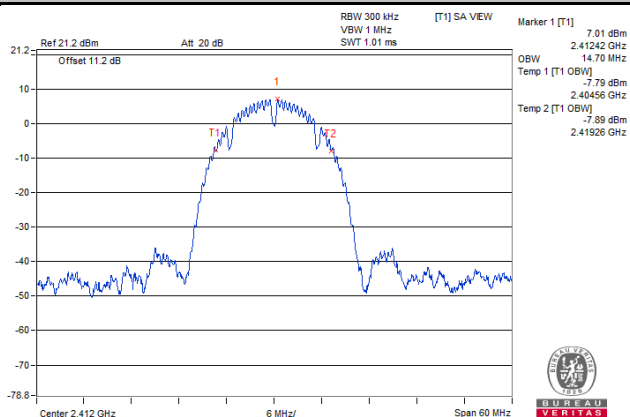

802.11g

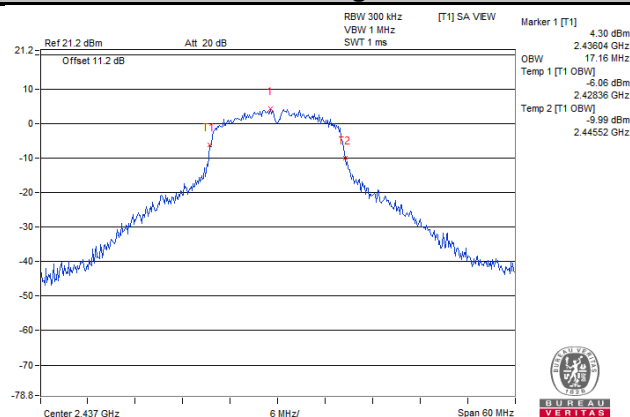

802.11n (HT20)

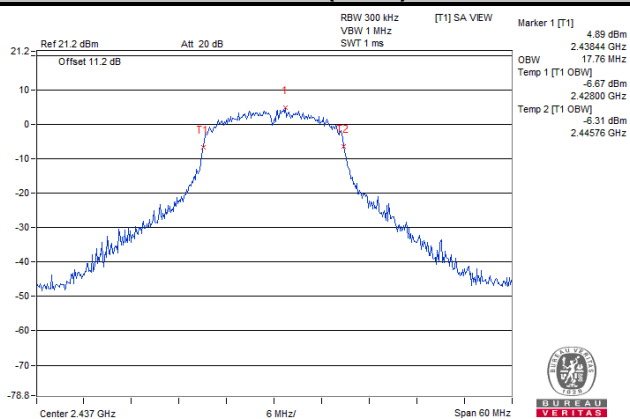

802.11n (HT40)

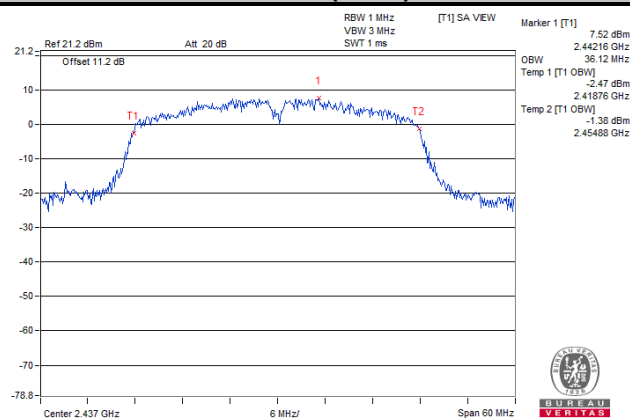

4.5 Conducted Output Power Measurement

4.5.1 Limits of Conducted Output Power Measurement

For systems using digital modulation in the 2400–2483.5 MHz bands: 1 Watt (30 dBm)

4.5.2 Test Setup

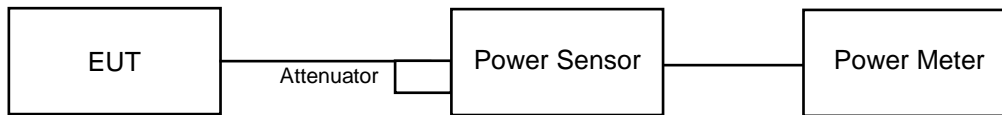

4.5.3 Test Instruments

Refer to section 4.1.2 to get information of above instrument.

4.5.4 Test Procedures

A peak power sensor was used on the output port of the EUT. A power meter was used to read the response of the peak power sensor. Record the power level.

4.5.5 Deviation from Test Standard

No deviation.

4.5.6 EUT Operating Conditions

The software provided by client to enable the EUT under transmission condition continuously at lowest, middle and highest channel frequencies individually.

4.5.7 Test Results

802.11b

Channel	Frequency (MHz)	Peak Power (mW)	Peak Power (dBm)	Limit (dBm)	Pass / Fail
1	2412	63.387	18.02	30	Pass
6	2437	66.834	18.25	30	Pass
11	2462	66.222	18.21	30	Pass

802.11g

Channel	Frequency (MHz)	Peak Power (mW)	Peak Power (dBm)	Limit (dBm)	Pass / Fail
1	2412	116.413	20.66	30	Pass
6	2437	111.944	20.49	30	Pass
11	2462	115.08	20.61	30	Pass

802.11n (HT20)

Channel	Frequency (MHz)	Peak Power (mW)	Peak Power (dBm)	Limit (dBm)	Pass / Fail
1	2412	113.24	20.54	30	Pass
6	2437	113.763	20.56	30	Pass
11	2462	115.878	20.64	30	Pass

802.11n (HT40)

Channel	Frequency (MHz)	Peak Power (mW)	Peak Power (dBm)	Limit (dBm)	Pass / Fail
3	2422	114.025	20.57	30	Pass
6	2437	108.643	20.36	30	Pass
9	2452	112.98	20.53	30	Pass

4.6 Power Spectral Density Measurement

4.6.1 Limits of Power Spectral Density Measurement

The Maximum of Power Spectral Density Measurement is 8 dBm.

4.6.2 Test Setup

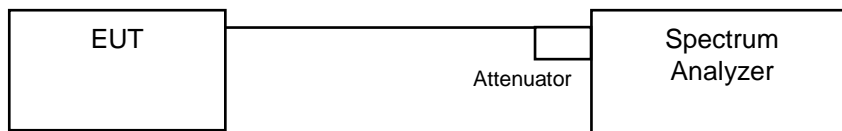

4.6.3 Test Instruments

Refer to section 4.1.2 to get information of above instrument.

4.6.4 Test Procedure

- a. Set analyzer center frequency to DTS channel center frequency.
- b. Set the span to 1.5 times the DTS bandwidth.
- c. Set the RBW to: $3 \text{ kHz} \leq \text{RBW} \leq 100 \text{ kHz}$.
- d. Set the VBW $\geq 3 \times \text{RBW}$.
- e. Detector = peak.
- f. Sweep time = auto couple.
- g. Trace mode = max hold.
- h. Allow trace to fully stabilize.
- i. Use the peak marker function to determine the maximum amplitude level within the RBW.

4.6.5 Deviation from Test Standard

No deviation.

4.6.6 EUT Operating Condition

The software provided by client to enable the EUT under transmission condition continuously at lowest, middle and highest channel frequencies individually.

4.6.7 Test Results

802.11b

Channel	Frequency (MHz)	PSD (dBm/3 kHz)	Limit (dBm/3 kHz)	Pass / Fail
1	2412	-5.52	8	Pass
6	2437	-5.16	8	Pass
11	2462	-5.22	8	Pass

802.11g

Channel	Frequency (MHz)	PSD (dBm/3 kHz)	Limit (dBm/3 kHz)	Pass / Fail
1	2412	-12.61	8	Pass
6	2437	-12.07	8	Pass
11	2462	-12.44	8	Pass

802.11n (HT20)

Channel	Frequency (MHz)	PSD (dBm/3 kHz)	Limit (dBm/3 kHz)	Pass / Fail
1	2412	-11.85	8	Pass
6	2437	-11.95	8	Pass
11	2462	-11.65	8	Pass

802.11n (HT40)

Channel	Frequency (MHz)	PSD (dBm/3 kHz)	Limit (dBm/3 kHz)	Pass / Fail
3	2422	-17.54	8	Pass
6	2437	-17.80	8	Pass
9	2452	-17.64	8	Pass

Spectrum Plot of Worst Value

802.11b

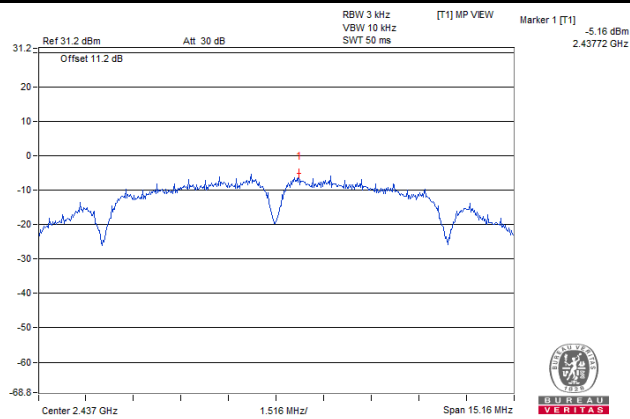

802.11g

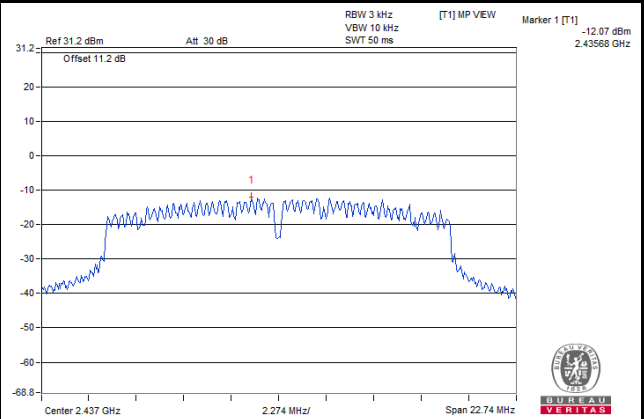

802.11n (HT20)

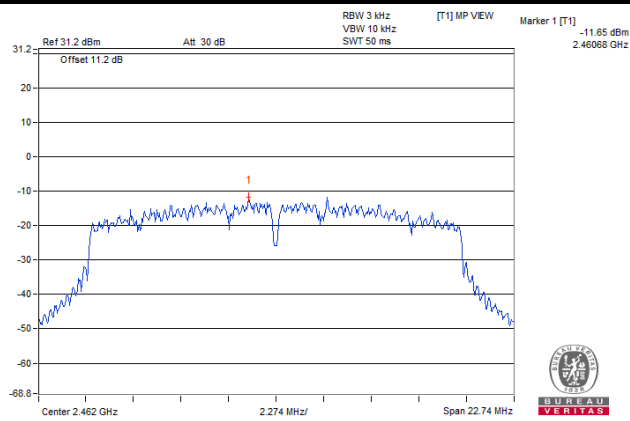

802.11n (HT40)

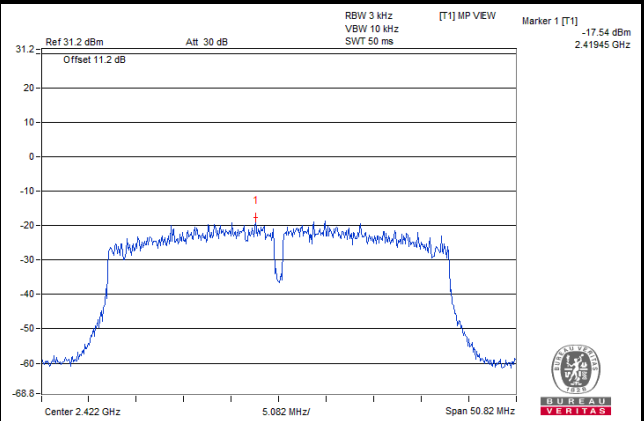

4.7 Conducted Out of Band Emission Measurement

4.7.1 Limits of Conducted Out of Band Emission Measurement

Below -20 dB of the highest emission level of operating band (in 100 kHz Resolution Bandwidth).

4.7.2 Test Setup

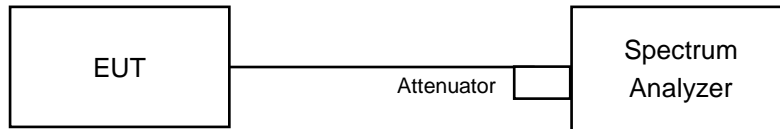

4.7.3 Test Instruments

Refer to section 4.1.2 to get information of above instrument.

4.7.4 Test Procedure

MEASUREMENT PROCEDURE REF

1. Set the RBW = 100 kHz.
2. Set the VBW \geq 300 kHz.
3. Detector = peak.
4. Sweep time = auto couple.
5. Trace mode = max hold.
6. Allow trace to fully stabilize.
7. Use the peak marker function to determine the maximum power level in any 100 kHz band segment within the fundamental EBW.

MEASUREMENT PROCEDURE OOB

1. Set RBW = 100 kHz.
2. Set VBW \geq 300 kHz.
3. Detector = peak.
4. Sweep = auto couple.
5. Trace Mode = max hold.
6. Allow trace to fully stabilize.
7. Use the peak marker function to determine the maximum amplitude level.

4.7.5 Deviation from Test Standard

No deviation.

4.7.6 EUT Operating Condition

The software provided by client to enable the EUT under transmission condition continuously at lowest, middle and highest channel frequencies individually.

4.7.7 Test Results

The spectrum plots are attached on the following images. D1 line indicates the highest level, and D2 line indicates the 20 dB offset below D1. It shows compliance with the requirement.

802.11b

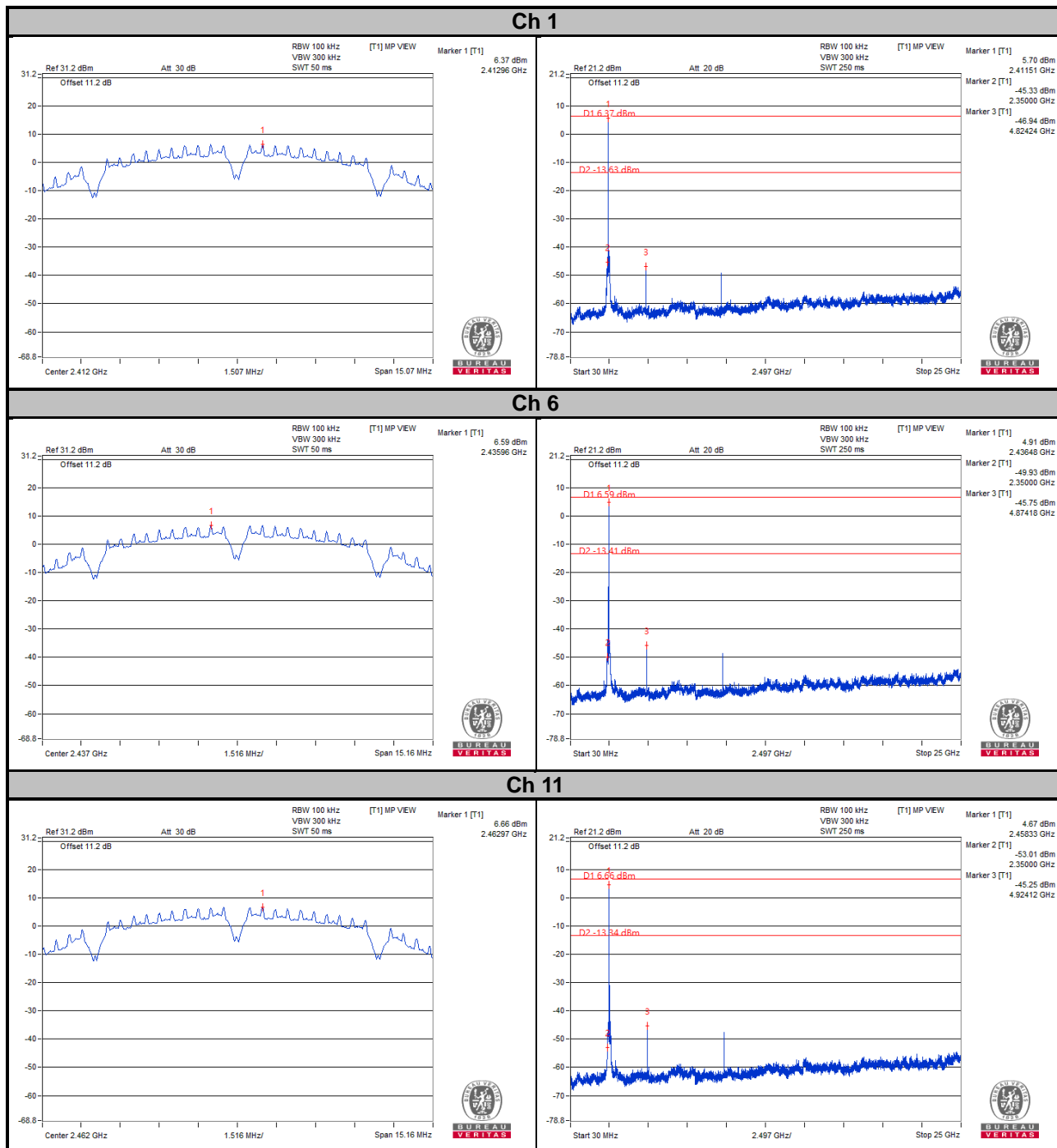

Ch 1 Band Edge

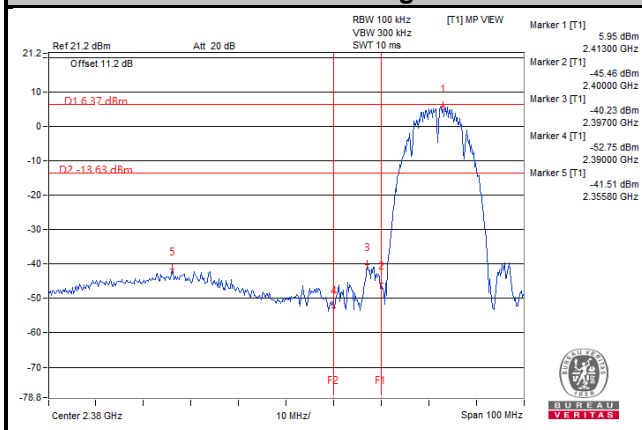

Ch 11 Band Edge

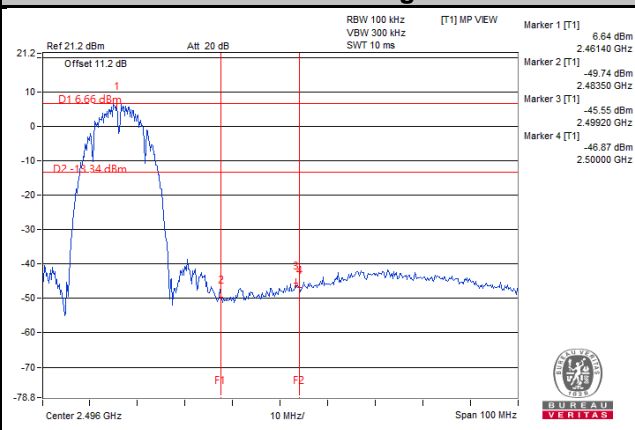

802.11g

Ch 1

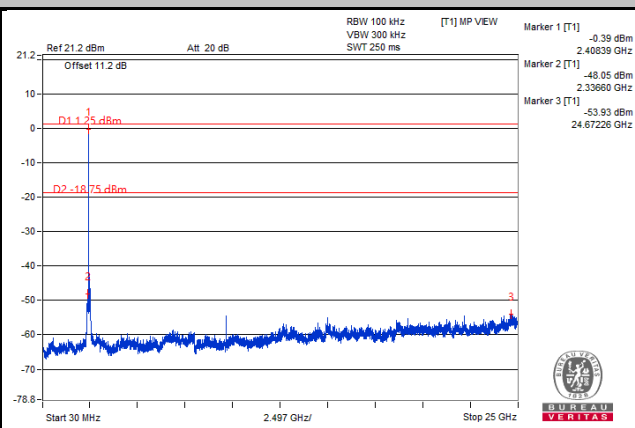
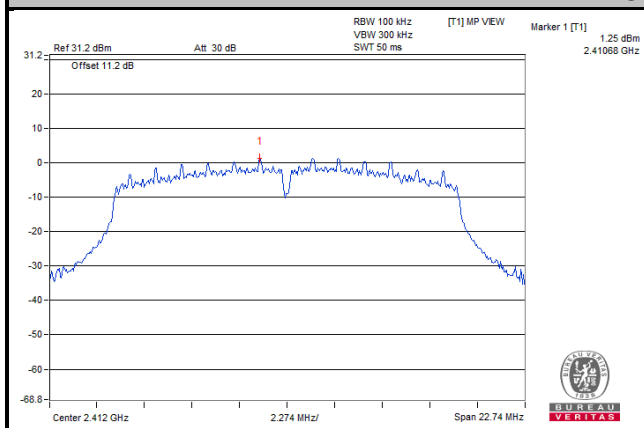

Ch 6

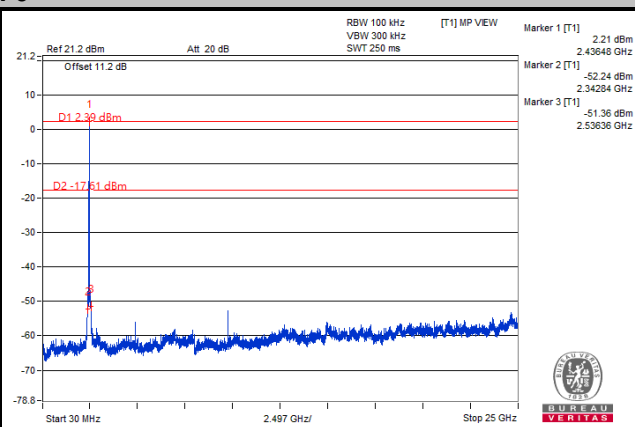
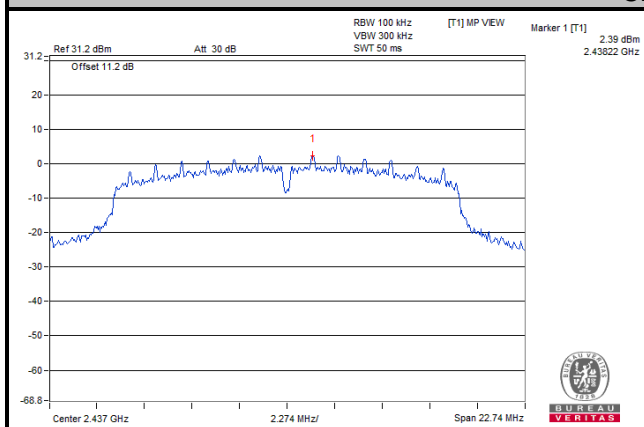

Ch 11

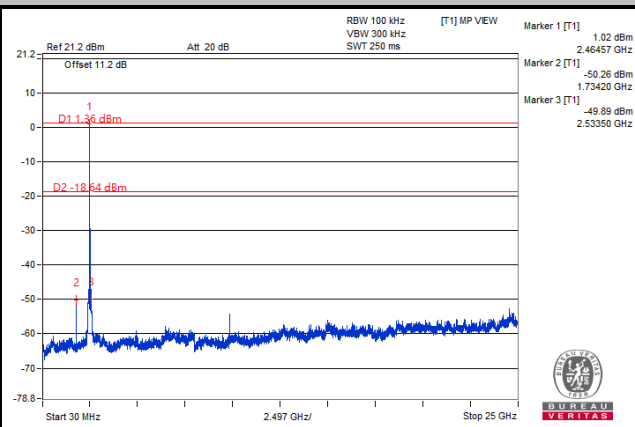
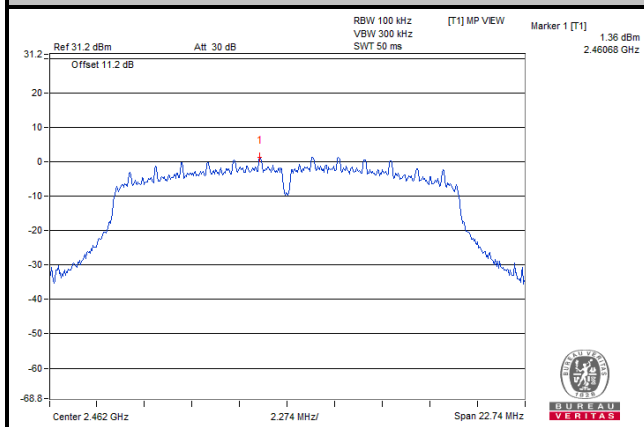

Ch 1 Band Edge

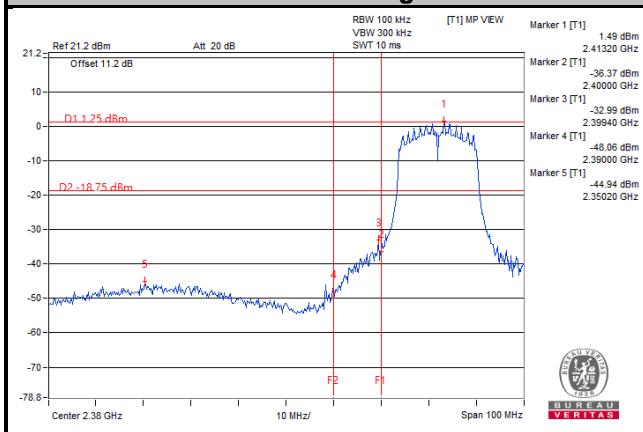

Ch 11 Band Edge

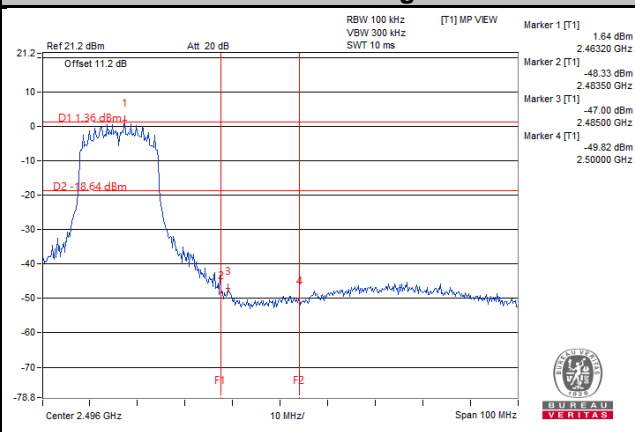

802.11n (HT20)

Ch 1

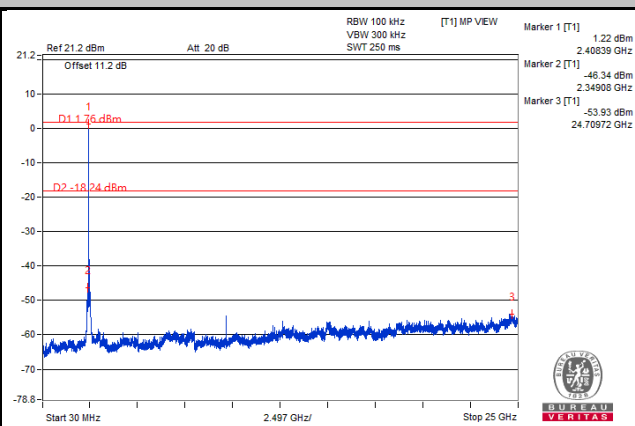
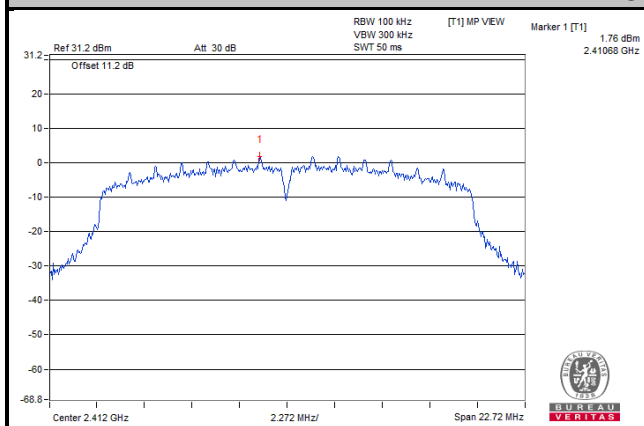

Ch 6

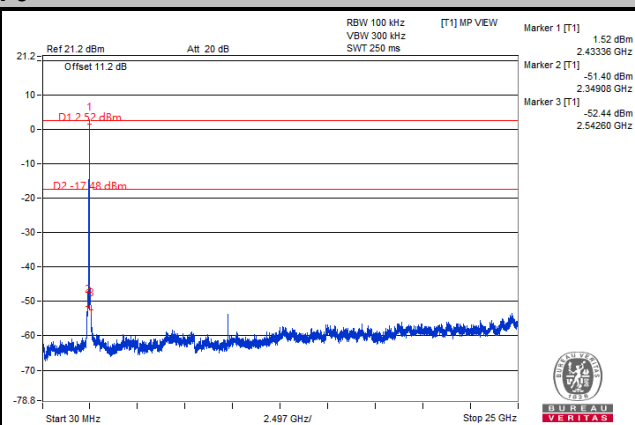
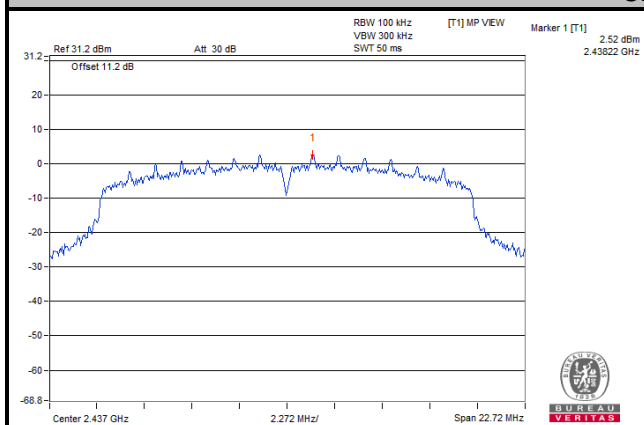

Ch 11

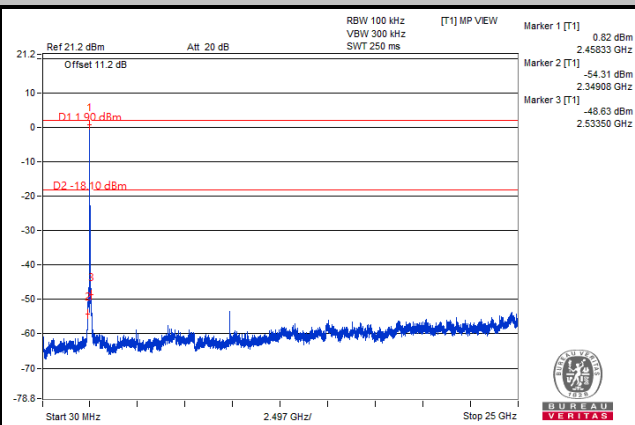
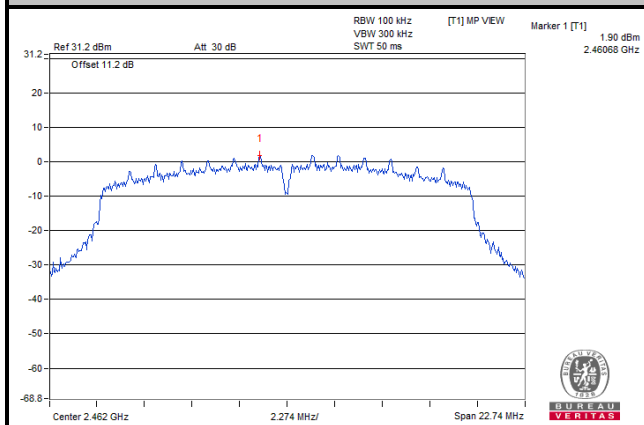

Ch 1 Band Edge

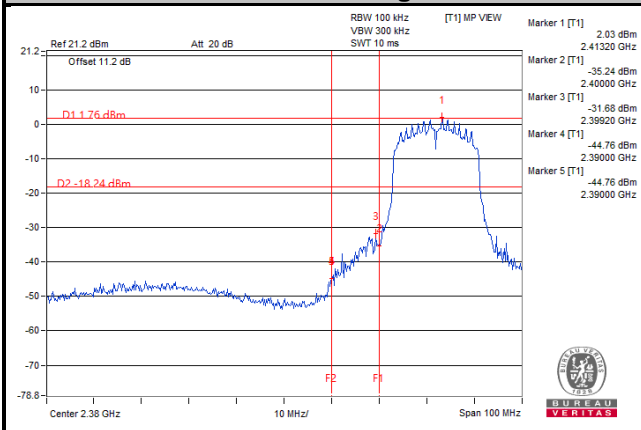

Ch 11 Band Edge

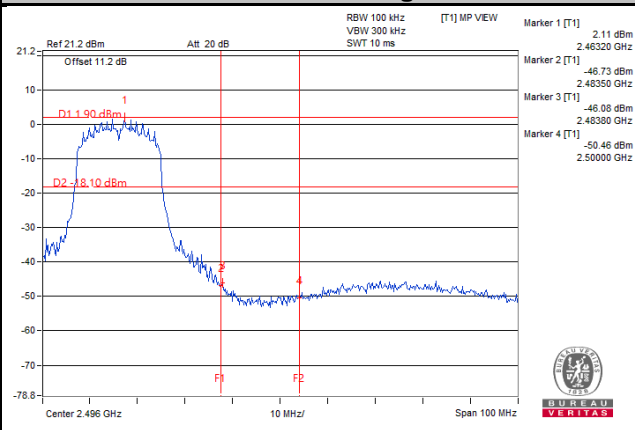

802.11n (HT40)

Ch 3

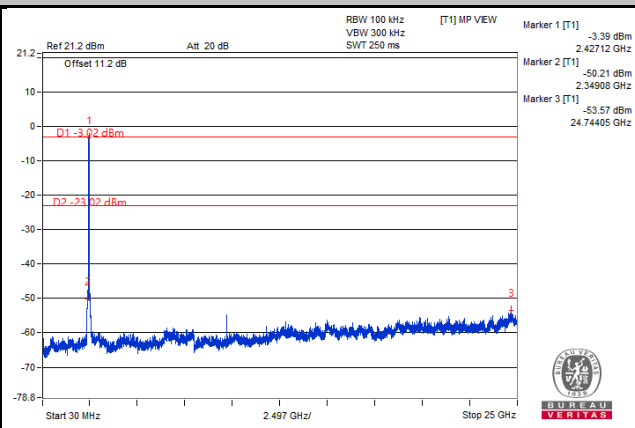
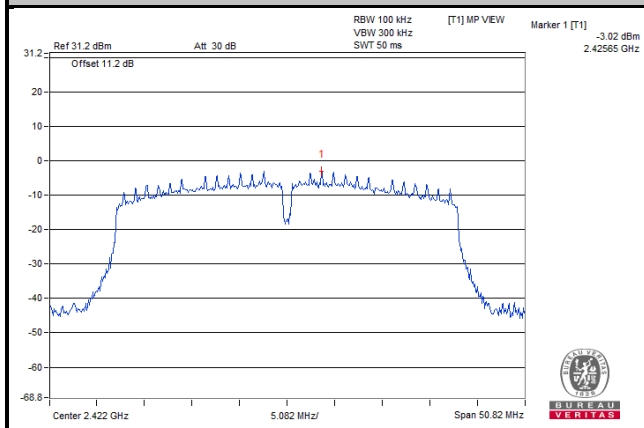

Ch 6

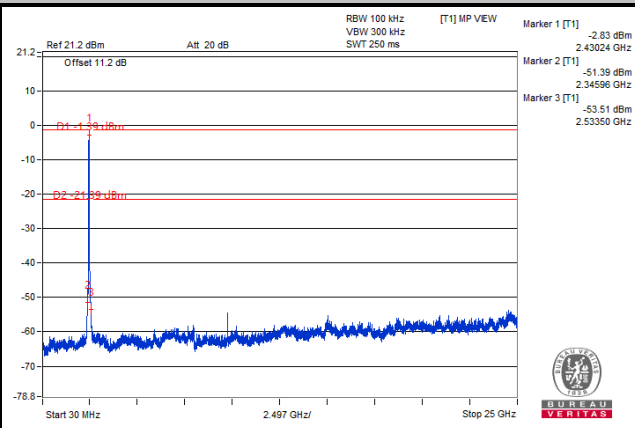
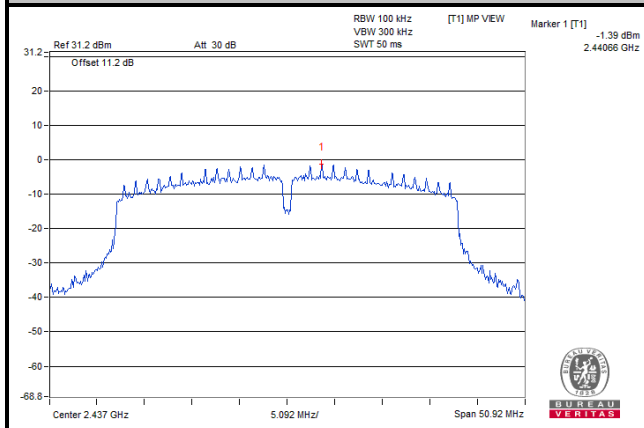

Ch 9

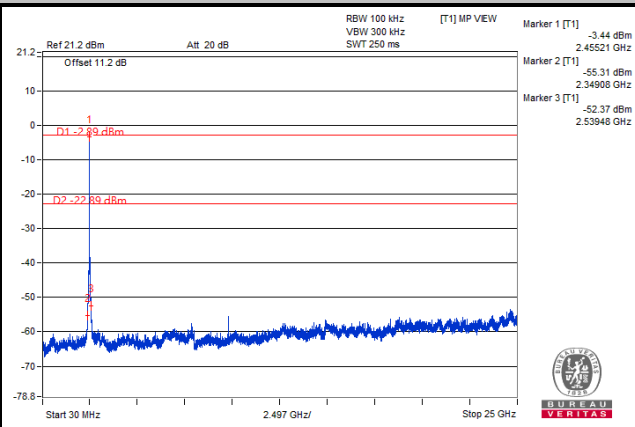
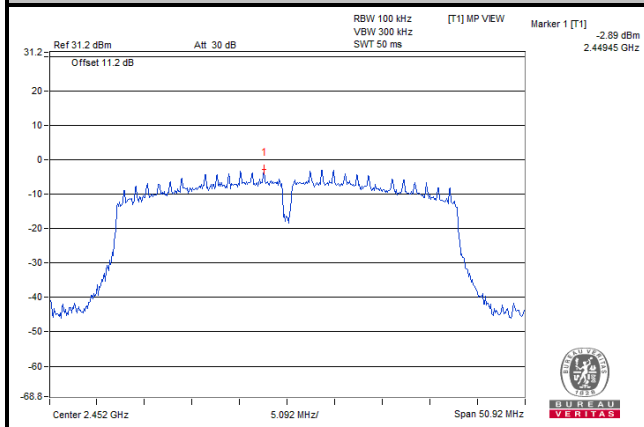

Ch 3 Band Edge

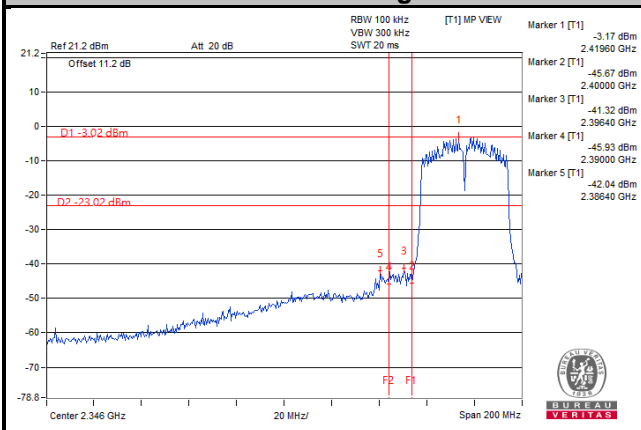

Ch 9 Band Edge

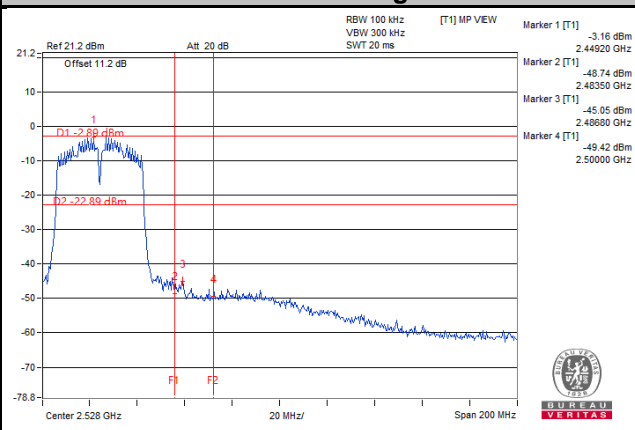

5 Pictures of Test Arrangements

Please refer to the attached file (Test Setup Photo).

Appendix – Information on the Testing Laboratories

We, Bureau Veritas Consumer Products Services (H.K.) Ltd., Taoyuan Branch, were founded in 1988 to provide our best service in EMC, Radio, Telecom and Safety consultation. Our laboratories are FCC recognized accredited test firms and accredited according to ISO/IEC 17025.

If you have any comments, please feel free to contact us at the following:

Linko EMC/RF Lab

Tel: 886-2-26052180

Fax: 886-2-26051924

Hsin Chu EMC/RF/Telecom Lab

Tel: 886-3-6668565

Fax: 886-3-6668323

Hwa Ya EMC/RF/Safety Lab

Tel: 886-3-3183232

Fax: 886-3-3270892

Email: service.adt@tw.bureauveritas.com

Web Site: www.bureauveritas-adt.com

The address and road map of all our labs can be found in our web site also.

--- END ---