

零件承认书

Part acknowledgement

供应商全称 Full name of supplier: 东莞捷瑞思科技有限公司

Dongguan Jerice Technology Co., Ltd.

供应商地址 Address of supplier: 东莞市大岭山朗湖路 96 号 (金雄达科技园 L 栋 3 楼)

96 Long Wu Road, Tai Ling Shan, Dongguan (3F, building L, Kam Hung Tat Science and Technology Park)

物料名称 Name of material: : A11 线圈

物料规格: Material specifications: 线圈 A11\6.3uH\单股单层\0.08*105P\10TS\磁片

φ43*1.0mm\开槽\材质 PC95\L=10mm\带背胶

机种型号 Type and model: W312

客户名称 Customer name: 络鑫电子

客户料号 Customer data: E28-00020

送样时间 Sample delivery time: 2023 年 10 月 05 日

备注 Notes: 新物料 New materials: 代料 Alternative:

承认结果 Acknowledge the results	<input type="checkbox"/> 合格 Qualified <input type="checkbox"/> 不合格 Disqualified
	不合格原因 Reasons for non-conformance:
	不合格承认书及样品处理方式 Acceptance of non-conformance and sample handling: <input type="checkbox"/> 退回采购 Return purchase <input type="checkbox"/> 销毁处理 Disposal

供应商签章 Signature of supplier		
申请人 Applicant	品质 Quality	核准 Approved
陆琳	梁梅香	陆如圣
承认章 Recognition Stamp		
日期 Date: 2023.10.05		

承认签章 Recognize the signature				
申请人 Applicant	测试员 Tester	工程 Project	品质 Quality	核准 Approved
承认章 Recognition Stamp				
日期 Date:				

一、目录： Table of contents

1. 封面 Cover	第 1-1 页
2. 目录 Table of contents	第 2-2 页
3. 产品图 Product drawings	第 3-3 页
4. 尺寸图 Size Map	第 4-4 页
5. 产品参数 Product parameters	第 5-5 页
6. 技术要求 Technical requirements	第 5-5 页
7. 电性参数 Electrical parameters	第 5-5 页
8. 包装 Packaging	第 6-6 页
9. 材料清单 Bill of materials	第 7-7 页

二、产品图面 Product drawing:

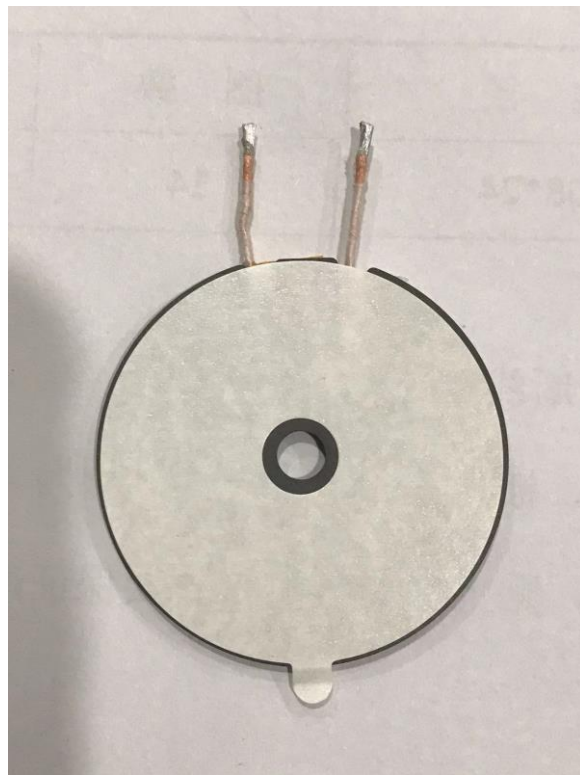
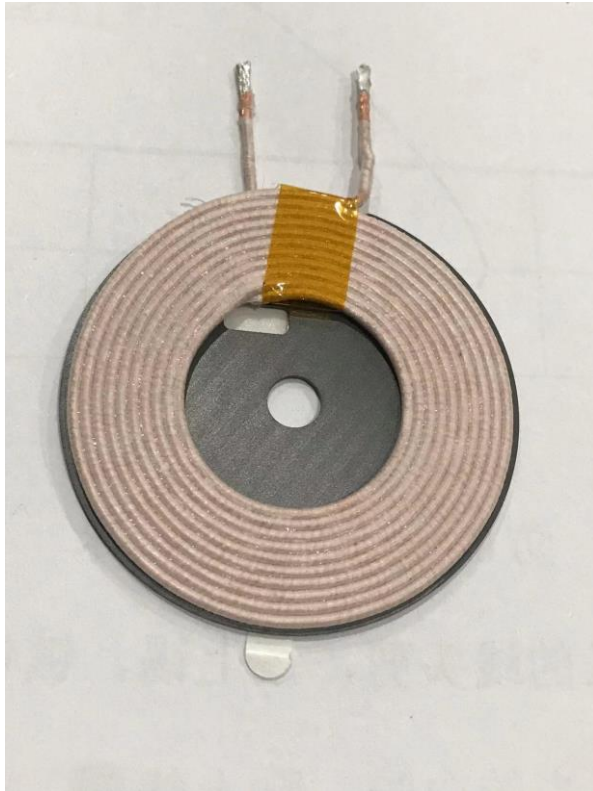

三、平面结构图 A plan: 单位:MM

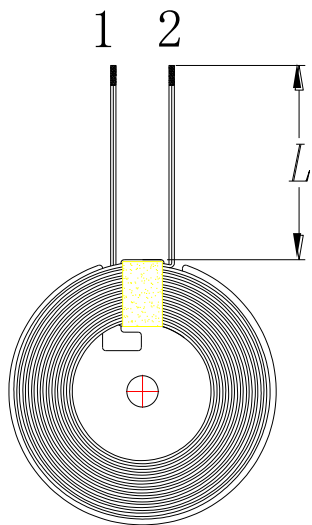
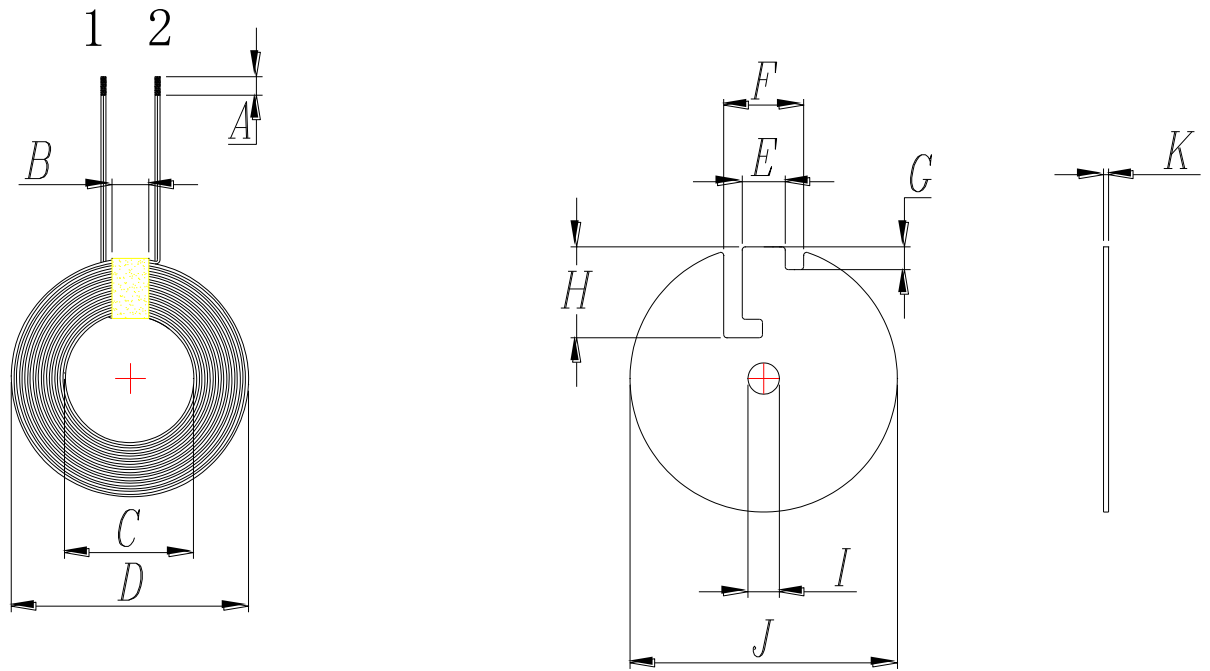

A	4.0±1
B	8
C	20.5±0.2
D	42±1
E	7±0.3
F	12±0.5
G	4.0±0.5
H	14.5±0.5
I	5.2±0.2
J	43.5±0.5
K	1.0±0.1
L	10±2

四、产品参数 Product parameters:

脚位 Feet	线径 Diameter of the line	圈数 Number of turns	备注 Notes
1 - 2	0.08*105P	10	丝包线 Silk-clad wire

五、技术要求 Technical requirements:

1. 固定好线头线尾，防止线松断线等现象
Fix the head and tail of thread to prevent loose and broken thread
2. 按客户要求把过长的线头剪，镀上锡，镀锡深度统一为 $4 \pm 1\text{MM}$
According to customer's requirements, the length of wire shears,
Tinning, tinning depth of $4 \pm 1\text{MM}$
3. 在磁片上点上适当的白胶，贴上线圈，过程中要保证产品表面干净整洁
In the magnetic point on the appropriate white glue, paste the coil, the process to ensure that the product surface clean and tidy
4. 所用磁片为双拼磁片，无破损
The disk used is double spliced disk, no damage
5. 附加工序（按客户要求）：成品背后加贴直径 42mm 的圆双面胶，后包装
Additional process (according to customer requirements) :
The finished product is covered with 42mm diameter round double-sided adhesive on the back, and then packed

六、电性参数 Electrical parameters:

1. 电感值，Q 值 Inductance value, Q value:

$$\text{PIN } 1 - 2 = 6.3 \pm 5\% \text{UH} \quad \text{Q 值} \geq 90$$

以上电感值以铨华 1062A 仪器，以 10KHZ/0.3Vrms 为标准或等同仪器。

Q 值以铨华 1062A 仪器，以 100KHZ/0.3Vrms 为标准或等同仪器

The above inductance values are based on chuanhua 1062A instrument, using 10KHZ/0.3 vrms as the standard or equivalent instrument. The Q value is based on chuanhua 1062A instrument and 100KHZ/0.3 vrms or equivalent instrument

七、包装 Packaging:



图 1: 单层泡棉托盘, 1 盒包装 150PCS

Figure 1: Single-layer foam tray, 1 box packing 150 pcs



图 2: 统一方向线头朝上整齐排放入盘中

Figure 2: Uniform Direction Line head up neatly into the disk



图 3: 放入包装箱, 每箱放置 4 层

Figure 3: put into the packing box, each box put 4 layers



图 4: 封箱, 用透明胶封箱

Figure 4: sealing the box with transparent glue

江西络鑫科技有限公司			
进料标签			客户: JX
供应商	LX1265		ROHS
订单号			
料号	E28-00020		
规格	G43-1.0-6.3UH-10MM		
数量	1080	单位	PCS
生产周期	2344		
生产批次	202301005001		
交货日期	2023/10/5		

图 5: 包装箱贴标签

Figure 5: Packaging label



图 6: 物料堆放, 整齐, 标签往外方便寻找物料

Figure 6: materials stacked, neat, labels to facilitate the search for materials

八、材料清单 Bill of materials:

序号 NO	名称 Name	材质 Material	供应商 Suppliers	备注 Notes
1	丝包线 Silk-clad wire	0.08*105P	维汉或等同 Uyghur or equivalent	
2	磁片 Disk	G43.5*5.2*1.0 (带孔双槽 L 型)	天通或等同 TX or equivalent	
3	锡 Tin	高温环保 Hightemperature environmental protection	千岛或等同 Thond Island or equivalent	
4	白胶 White glue	BY882	宝月或等同 Treasure month or equivalent	
5	双面胶 Double-sided glue	ø42*5mm	鸿辉或等同 Hung Fai or equivalent	
6	高温胶带 High temperature adhesive tape	8MM		