

# TEST REPORT

**FCC ID: 2AABZE-MOUNT**

**Applicant** : Aputure Imaging Industries Co., Ltd  
**Address** : 3rd Floor, Building 21, Longjun  
Industrial estate, Longhua, Bao'an, Shenzhen, P.R.China

**Equipment Under Test (EUT):**

Name	:	wireless remote adapter
Model	:	DEC for E-mount

In Accordance with: FCC PART 15, SUBPART C : 2014 (Section 15.249)

Report No : C1850076 01  
Date of Test : March 13, 2015 to April 1, 2015  
Date of Issue : April 1, 2015  
Test Result : PASS

In the configuration tested, the EUT complied with the standards specified above

Authorized Signature



(Mark Zhu)  
General Manager

The manufacture should ensure that all the products in series production are in conformity with the product sample detailed in this report.

If the product in this report is used in any configuration other than that detailed in the report, the manufacturer must ensure the new system complies with all relevant standards. Any mention of Shenzhen Certification Technology Service Co., Ltd. Or test done by Shenzhen Certification Technology Service Co., Ltd. Approvals in connection with, distribution or use of the product described in this report must be approved by Shenzhen Certification Technology Service Co., Ltd. Approvals in writing.

## TABLE OF CONTENT

<b>1</b>	<b>General Information</b>	<b>3</b>
1.1	Description of Device (EUT)	3
1.2	Description of Test Facility	4
<b>2</b>	<b>EMC Equipment List</b>	<b>4</b>
<b>3</b>	<b>Test Procedure</b>	<b>5</b>
<b>4</b>	<b>Summary of Measurement</b>	<b>6</b>
4.1	Summary of test result	6
4.2	Test connection	6
4.3	Assistant equipment used for test	6
4.4	Test mode	7
4.5	Test Conditions	7
4.6	Measurement Uncertainty (95% confidence levels, k=2)	7
<b>5</b>	<b>Spurious Emission</b>	<b>8</b>
5.1	Radiation Emission	8
5.1.1	Radiation Emission Limits(15.209)	8
5.1.2	Test Setup	8
5.1.3	Test Procedure	10
5.1.4	Test Equipment Setting For emission test Result.	10
5.1.5	Test Condition	10
5.1.6	Test Result	10
<b>6</b>	<b>POWER LINE CONDUCTED EMISSION</b>	<b>15</b>
6.1	Conducted Emission Limits(15.207)	15
6.2	Test Setup	15
6.3	Test Procedure	16
6.4	Test Results	16
<b>7</b>	<b>Bandwidth</b>	<b>19</b>
7.1	Test limit	19
7.2	Method of measurement	19
7.3	Test Setup	19
7.4	Test Results	19
<b>8</b>	<b>Band Edge Check</b>	<b>22</b>
8.1	Test limit	22
8.2	Test Procedure	22
8.3	Test Setup	22
8.4	Test Result	22
<b>9</b>	<b>Antenna Requirement</b>	<b>24</b>
9.1	Standard Requirement	24
9.2	Antenna Connected Construction	24
9.3	Result	24
<b>10</b>	<b>Photographs of Test Setup</b>	<b>25</b>
4.7	Photos of Radiated emission	25
4.8	Photos of Conducted Emission test	26
<b>11</b>	<b>Photographs of EUT</b>	<b>27</b>

# 1 General Information

## 1.1 Description of Device (EUT)

EUT	: wireless remote adapter
Model No.	: DEC for E-mount
DIFF	N/A
Trade mark	: 
Power supply	: DC3.7V from battery or DC 5V from USB port.
Radio Technology	: FSK
Operation frequency	: 2405-2450MHz
Channel No.	91Channels
Modulation	: FSK
Hardware Version	: AP-040 TX MAIN V1.1
Software	: N/A
S/N	: N/A
Antenna Type	: PCB antenna connected to main board by cable with ipexconnector, max gain 0dBi.
Applicant	: Aputure Imaging Industries Co., Ltd
Address	: 3rd Floor,Building 21, Longjun Industrial estate,Longhua, Bao'an, Shenzhen, P.R.China
Manufacturer	: Aputure Imaging Industries Co., Ltd
Address	: 3rd Floor,Building 21, Longjun Industrial estate,Longhua, Bao'an, Shenzhen, P.R.China

## 1.2 Description of Test Facility

Shenzhen Certification Technology Service Co., Ltd.  
 2F, Building B, East Area of Nanchang Second Industrial Zone,  
 Gushu 2nd Road, Bao'an District, Shenzhen 518126, P.R. China  
 FCC Registered No.:197647

## 2 EMC Equipment List

Equipment	Manufacture	Model No.	Serial No.	Last cal.	Cal Interval
3m Semi-Anechoic	ETS-LINDGREN	N/A	SEL0017	2015.01.19	1 Year
Spectrum analyzer	Agilent	E4407B	MY49510055	2015.01.19	1 Year
Receiver	R&S	ESCI	101165	2015.01.19	1 Year
Bilog Antenna	SCHWARZBECK	VULB 9168	9168-438	2015.01.21	2 Year
Horn Antenna	SCHWARZBECK	BBHA 9120 D	BBHA 9120 D(1201)	2015.01.21	2 Year
Horn Antenna	SCHWARZBECK	BBHA 9170	BBHA 9170 D(1432)	2015.01.21	2 Year
Active Loop Antenna	Beijing Daze	ZN30900A	SEL0097	2015.01.19	1 Year
Cable	Resenberger	SUCOFLEX 104	MY6562/4	2015.01.19	1 Year
Cable	Resenberger	SUCOFLEX 104	309972/4	2015.01.19	1 Year
Cable	Resenberger	SUCOFLEX 104	329112/4	2015.01.19	1 Year
Pre-amplifier	SCHWARZBECK	BBV9743	9743-019	2015.01.19	1 Year
Pre-amplifier	Quietek	AP-180C	CHM-0602012	2015.01.19	1 Year
Test Receiver	Rohde & Schwarz	ESCI	101165	2015.01.19	1 Year
L.I.S.N.#1	Schwarzbeck	NSLK8126	8126466	2015.01.19	1 Year
L.I.S.N.#2	ROHDE&SCHWARZ	ENV216	101043	2015.01.19	1 Year

### 3 Test Procedure

**POWER LINE CONDUCTED INTERFERENCE:** The test procedure used was ANSI Standard C63.4-2009 using a 50 u H LISN. Both Lines were observed. The bandwidth of the receiver was 10kHz with an appropriate sweep speed. The ambient temperature of the EUT was 25°C with a humidity of 58%.

**RADIATION INTERFERENCE:** The test procedure used was ANSI Standard C63.4-2009 using a ANRITSU spectrum analyzer with a pre-selector. The analyzer was calibrated in dB above a micro volt at the output of the antenna. The resolution bandwidth was 100kHz and the video bandwidth was 300 kHz up to 1 GHz and 1 MHz with a video BW of 3MHz above 1 GHz. The ambient temperature of the EUT was 25°C with a humidity of 58%.

**FORMULA OF CONVERSION FACTORS:** The Field Strength at 3m was established by adding the meter reading of the spectrum analyzer (which is set to read in units of dBuV) to the antenna correction factor supplied by the antenna manufacturer and cable loss. The antenna correction factors and cable loss are stated in terms of dB. The gain of the Pre-selector was accounted for in the Spectrum Analyzer Meter Reading.

Example:

Freq (MHz) METER READING + ACF + CABLE = FS

33.20 dBuV + 10.36 dB + 0.9 dB= 44.46 dBuV/m @ 3m

**ANSI STANDARD C63.4-2009 10.1.7 MEASUREMENT PROCEDURES:** The EUT was placed on a table 80 cm high and with dimensions of 1m by 1.5m. The EUT was placed in the center of the table (1.5m side). The table used for radiated measurements is capable of continuous rotation. When an emission was found, the table was rotated to produce the maximum signal strength. At this point, the antenna was raised and lowered from 1m to 4m. The antenna was placed in both the horizontal and vertical planes. The situation was similar for the conducted measurement except that the table did not rotate. The EUT was setup as described in ANSI Standard C63.4-2009 10.1.7 with the EUT 40 cm from the vertical ground wall.

## 4 Summary of Measurement

### 4.1 Summary of test result

Test Item	Test Requirement	Standard Paragraph	Result
Spurious Emission	FCC PART 15: 2014	Section 15.249&15.209	Compliance
Conduction Emission	FCC PART 15: 2014	Section 15.207	Compliance
Occupied bandwidth	FCC PART 15: 2014	Section 15.249	Compliance
Band edge Requirement	FCC PART 15: 2014	Section 15.249	Compliance
Antenna Requirement	FCC PART 15: 2014	Section 15.203	Compliance

Note: The EUT has been tested at Continual Transmitting mode in maximum power level (Fully charged battery is used during the test)

EUT is configured to transmit continuously (Duty cycle) is 100% , average correction factor =  $20 \log 1=0$

### 4.2 Test connection

1, EUT was placed on a turn table, which is 0.8 meter high above ground.

**TX Mode:**



### 4.3 Assistant equipment used for test

Description	:	Notebook, adapter
Manufacturer	:	Dell, Chicony
Model No.	:	D430, A11-065N1A

#### 4.4 Test mode

The EUT was used to control EUT work in Continuous TX mode, and select test channel, wireless mode

##### Channel List

Channel No.	Frequency (MHz)	Channel No.	Frequency (MHz)	Channel No.	Frequency (MHz)
1	2405	---	----	----	----
2	2405.5	46	2427.5	88	2448.5
3	2406	47	2428	89	2449
4	2406.5	48	2428.5	90	2449.5
5	2407	49	2429	91	2450

#### 4.5 Test Conditions

Temperature range	21-25°C
Humidity range	40-75%
Pressure range	86-106kPa

#### 4.6 Measurement Uncertainty (95% confidence levels, k=2)

Item	MU	Remark
Uncertainty for Power point Conducted Emissions Test	2.42dB	
Uncertainty for Radiation Emission test in 3m chamber (below 30MHz)	2.13 dB	Polarize: V
	2.57dB	Polarize: H
Uncertainty for Radiation Emission test in 3m chamber (30MHz to 1GHz)	3.54dB	Polarize: V
	4.1dB	Polarize: H
Uncertainty for Radiation Emission test in 3m chamber (1GHz to 25GHz)	2.08dB	Polarize: H
	2.56dB	Polarize: V
Uncertainty for radio frequency	1×10 <sup>-9</sup>	
Uncertainty for DC and low frequency voltages	0.06%	

## 5 Spurious Emission

### 5.1 Radiation Emission

#### 5.1.1 Radiation Emission Limits(15.209)

Frequencies (MHz)	Field Strength (micorvolts/meter)	Measurement Distance (meters)
0.009~0.490	2400/F(KHz)	300
0.490~1.705	24000/F(KHz)	30
1.705~30.0	30	30
30~88	100	3
88~216	150	3
216~960	200	3
Above 960	500	3

Harmonic emissions limits comply with below 54 dBuV/m at 3m. Other emissions radiated outside of the specified frequency bands, except for harmonics, shall be attenuated by at least 50 dB below the level of the fundamental or comply with the radiated emissions limits specified in section 15.209(a) limit in the table below has to be followed.

**NOTE:**

- a) The tighter limit applies at the band edges.
- b) Emission Level(dB uV/m)=20log Emission Level(Uv/m)

#### 5.1.2 Test Setup

See the next page

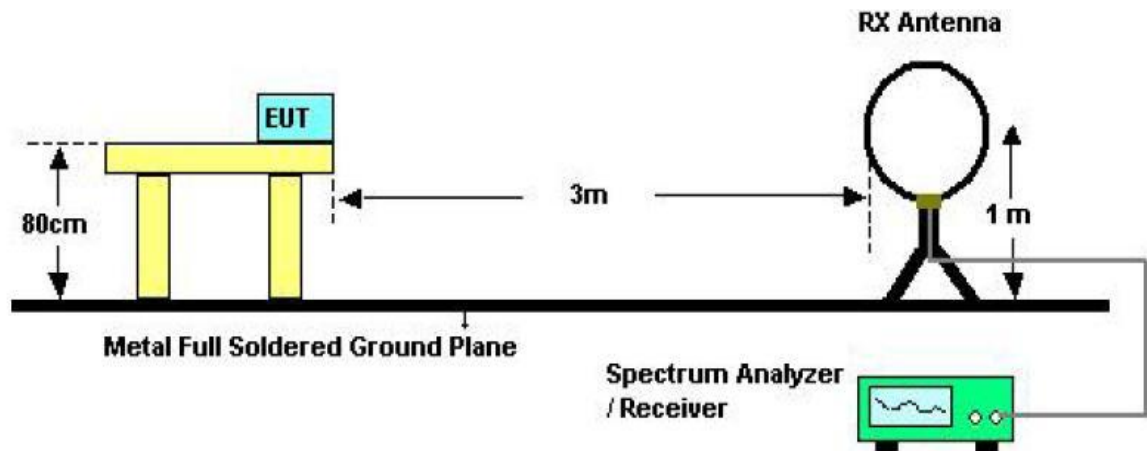

Below 30MHz Test Setup



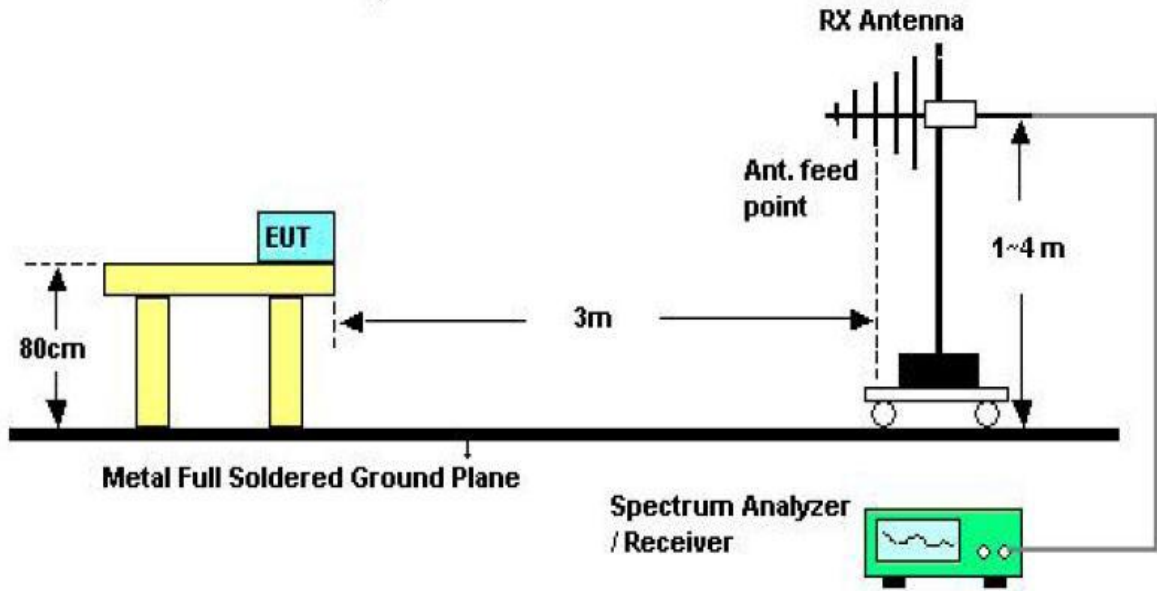

Above 30MHz Test Setup

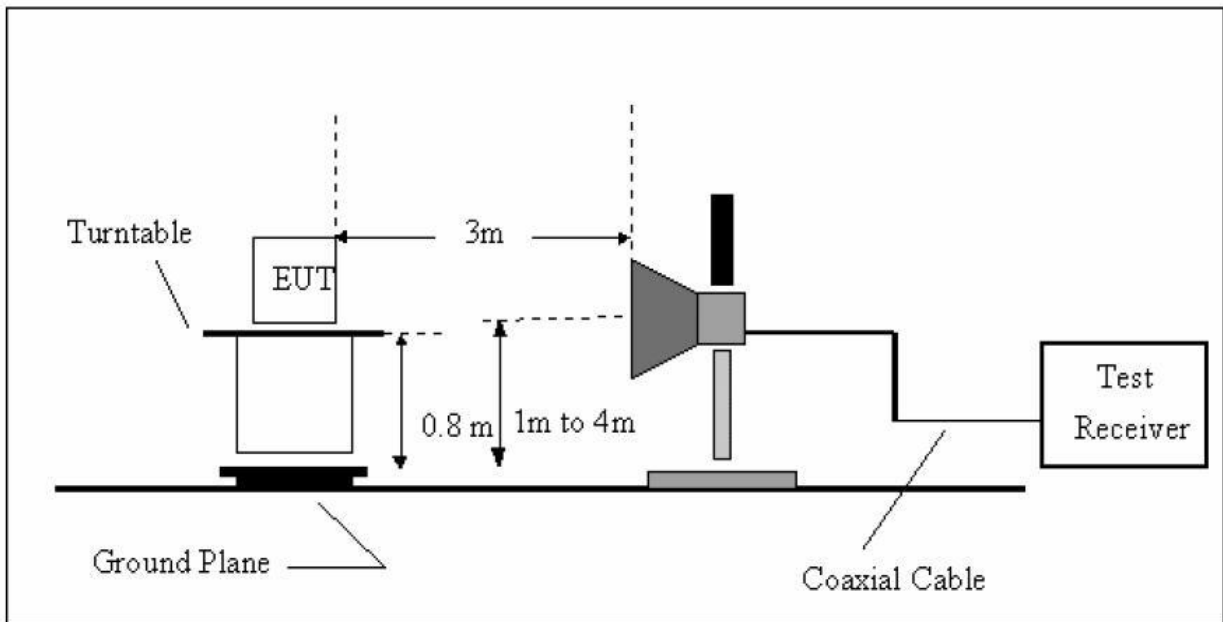

Above 1GHz Test Setup

### 5.1.3 Test Procedure

- a) The measuring distance of 3m shall be used for measurements at frequency up to 1GHz and above 1GHz, The EUT was placed on a rotating 0.8 m high above ground, The table was rotated 360 degrees to determine the position of the highest radiation
- b) The Test antenna shall vary between 1m and 4m, Both Horizontal and Vertical antenna are set of make measurement.
- c) The initial step in collecting conducted emission data is a spectrum analyzer Peak detector mode pre-scanning the measurement frequency range. Significant Peaks are then marked. and then Qusia Peak Detector mode premeasured
- d) If Peak value comply with QP limit Below 1GHz.The EUT deemed to comply with QP limit. But the Peak value and average value both need to comply with applicable limit above 1GHz.
- e) For the actual test configuration, please see the test setup photo.
- f) Test for all x, y, z axes is performed and only the worst case of x axes was recorded in the test report.

### 5.1.4 Test Equipment Setting For emission test Result.

9KHz~150KHz	RBW 200Hz	VBW1KHz
150KHz~30MHz	RBW 9KHz	VBW 30KHz
30MHz~1GHz	RBW 120KHz	VBW 300KHz
Above 1GHz	RBW 1MHz	VBW 3MHz

### 5.1.5 Test Condition

Continual Transmitting in maximum power.

### 5.1.6 Test Result

We have scanned the 10th harmonic from 9KHz to the EUT.  
Detailed information please see the following page.

From 9KHz to 30MHz: Conclusion: PASS

Note: The amplitude of spurious emissions which are attenuated by more than 20dB below the permissible value has no need to be reported.

Remark: Only show the test data of the worst Channel in this report.

From 30MHz to 1000MHz: Conclusion: PASS

Below 1GHz

30—1000MHz Radiated emission Test result									
EUT: wireless remote adapter					M/N: DEC for E-mount				
Power: DC 5.0V From USB Port									
Test date: 2015-03-17 Test site: 3m Chamber Tested by: Store Chu									
Test mode: Tx Mode									
Antenna polarity: Vertical									
No	Freq (MHz)	Read Level (dBUV/m)	Antenna Factor (dB/m)	Cable loss(dB)	Amp Factor (dB)	Result (dBUV/m)	Limit (dBUV/m)	Margin (dB)	Remark
1	47.99	48.26	13.59	0.09	31.83	30.11	40	9.89	PK
2	71.83	49.16	10.51	0.19	31.69	28.17	40	11.83	PK
3	83.82	46.92	9.35	0.23	31.53	24.97	40	15.03	PK
4	185.79	48.34	10.95	0.57	31.00	28.86	43.5	14.64	PK
5	/	/							
	/	/							
Antenna Polarity: Horizontal									
1	47.99	50.16	13.59	0.09	31.83	32.01	40	7.99	PK
2	71.83	49.76	10.51	0.19	31.69	28.77	40	11.23	PK
3	83.82	45.61	9.35	0.23	31.53	23.66	40	16.34	PK
4	185.79	47.24	10.95	0.57	31.00	27.76	43.5	15.74	PK
5									
	/	/							
Note:									
1, Measuring frequency from 30MHz to 1GHz									
2, Spectrum Set for PK measure: RBW=100KHz, VBW=300KHz, Sweep time=Auto, Detector: PK									
3, Result = Read level + Antenna factor + cable loss-Amp factor									
4, All the other emissions not reported were too low to read and deemed to comply with FCC limit.									
5: All channel of low, middle and high channel has been tested, and only worst data of low channel is listed in this report.									

## Radiated Emissions Result of Inside band and out of band

1GHz—25GHz Radiated emission Test result									
EUT: wireless remote adapter					M/N: DEC for E-mount				
Power: DC 5.0V From USB Port									
Test date: 2015-03-17 Test site: 3m Chamber Tested by: Store Chu									
Test mode: 2405MHz									
Antenna polarity: Vertical									
No	Freq (MHz)	Read Level (dBUV/m)	Antenna Factor (dB/m)	Cable loss(dB)	Amp Factor (dB)	Result (dBUV/m)	Limit (dBUV/m)	Margin (dB)	Remark
1	2405	97.26	27.61	3.94	34.97	93.84	114	20.16	PK
2	2405	77.65	27.61	3.94	34.97	74.23	94	19.77	AV
3	4810	55.67	31.26	5.7	34.2	58.43	74	15.57	PK
4	4810	43.48	31.26	5.7	34.2	46.24	54	7.76	AV
5	7215	46.75	36.64	7.09	33.08	57.4	74	16.6	PK
6	7215	33.02	36.64	7.09	33.08	43.67	54	10.33	AV
	/	/							
	/	/							
Antenna Polarity: Horizontal									
1	2405	95.18	27.61	3.94	34.97	91.76	114	22.24	PK
2	2405	75.32	27.61	3.94	34.97	71.9	94	22.1	AV
3	4810	53.26	31.26	5.7	34.2	56.02	74	17.98	PK
4	4810	40.77	31.26	5.7	34.2	43.53	54	10.47	AV
5	7215	43.29	36.64	7.09	33.08	53.94	74	20.06	PK
6	7215	31.86	36.64	7.09	33.08	42.51	54	11.49	AV
	/	/							
	/	/							
Note:									
1,Measuring frequency from 1GHz to 25GHz									
2,Spectrum Set for PK measure: RBW=1MHz, VBW=1MHz, Sweep time=Auto, Detector: PK									
2,Spectrum Set for AV measure: RBW=1MHz, VBW=3MHz, Sweep time=Auto, Detector: RMS									
3, Result = Read level + Antenna factor + cable loss-Amp factor									
4, All the other emissions not reported were too low to read and deemed to comply with FCC limit.									

EUT: wireless remote adapter M/N: DEC for E-mount									
Power: DC 5.0V From USB Port									
Test date: 2015-03-17 Test site: 3m Chamber Tested by: Store Chu									
Test mode: 2427.5MHz									
Antenna polarity: Vertical									
No	Freq (MHz)	Read Level (dBuV/m)	Antenna Factor (dB/m)	Cable loss(dB)	Amp Factor (dB)	Result (dBuV/m)	Limit (dBuV/m)	Margin (dB)	Remark
1	2427.5	97.11	27.61	3.95	34.97	93.7	114	20.3	PK
2	2427.5	78.61	27.61	3.95	34.97	75.2	94	18.8	AV
3	4855	53.61	31.35	5.72	34.16	56.52	74	17.48	PK
4	4855	42.51	31.35	5.72	34.16	45.42	54	8.58	AV
5	7282.5	45.17	36.56	7.12	33.11	55.74	74	18.26	PK
6	7282.5	32.08	36.56	7.12	33.11	42.65	54	11.35	AV
	/	/							
Antenna Polarity: Horizontal									
1	2427.5	94.28	27.61	3.95	34.97	90.87	114	23.13	PK
2	2427.5	73.59	27.61	3.95	34.97	70.18	94	23.82	AV
3	4855	51.26	31.35	5.72	34.16	54.17	74	19.83	PK
4	4855	33.06	31.35	5.72	34.16	35.97	54	18.03	AV
5	7282.5	42.94	36.56	7.12	33.11	53.51	74	20.49	PK
6	7282.5	32.56	36.56	7.12	33.11	43.13	54	10.87	AV
	/	/							
Note:									
1, Measuring frequency from 1GHz to 25GHz									
2,Spectrum Set for PK measure: RBW=1MHz, VBW=1MHz, Sweep time=Auto, Detector: PK									
2,Spectrum Set for AV measure: RBW=1MHz, VBW=3MHz, Sweep time=Auto, Detector: RMS									
3, Result = Read level + Antenna factor + cable loss-Amp factor									
4, All the other emissions not reported were too low to read and deemed to comply with FCC limit.									

EUT: wireless remote adapter M/N: DEC for E-mount									
Power: DC 5.0V From USB Port									
Test date: 2015-03-17 Test site: 3m Chamber Tested by: Store Chu									
Test mode: 2450MHz									
Antenna polarity: Vertical									
No	Freq (MHz)	Read Level (dBUV/m)	Antenna Factor (dB/m)	Cable loss (dB)	Amp Factor (dB)	Result (dBUV/m)	Limit (dBUV/m)	Margin (dB)	Remark
1	2450	94.77	27.6	3.98	34.97	91.38	114	22.62	PK
2	2450	72.86	27.6	3.98	34.97	69.47	94	24.53	AV
3	4900	50.36	31.41	5.76	34.12	53.41	74	20.59	PK
4	4900	31.53	31.41	5.76	34.12	34.58	54	19.42	AV
5	7350	41.82	36.58	7.15	33.14	52.41	74	21.59	PK
6	7350	32.91	36.58	7.15	33.14	43.5	54	10.5	AV
	/	/							
Antenna Polarity: Horizontal									
1	2450	93.15	27.6	3.98	34.97	89.76	114	24.24	PK
2	2450	72.44	27.6	3.98	34.97	69.05	94	24.95	AV
3	4900	50.23	31.41	5.76	34.12	53.28	74	20.72	PK
4	4900	32.06	31.41	5.76	34.12	35.11	54	18.89	AV
5	7350	41.79	36.58	7.15	33.14	52.38	74	21.62	PK
6	7350	32.85	36.58	7.15	33.14	43.44	54	10.56	AV
	/	/							
Note:									
1, Measuring frequency from 1GHz to 25GHz									
2, Spectrum Set for PK measure: RBW=1MHz, VBW=1MHz, Sweep time=Auto, Detector: PK									
2,Spectrum Set for AV measure: RBW=1MHz, VBW=3MHz, Sweep time=Auto, Detector: RMS									
3, Result = Read level + Antenna factor + cable loss-Amp factor									
4, All the other emissions not reported were too low to read and deemed to comply with FCC limit.									

## 6 POWER LINE CONDUCTED EMISSION

### 6.1 Conducted Emission Limits(15.207)

Frequency MHz	Limits dB( $\mu$ V)	
	Quasi-peak Level	Average Level
0.15 -0.50	66 -56*	56 - 46*
0.50 -5.00	56	46
5.00 -30.00	60	50

Notes: 1. \*Decreasing linearly with logarithm of frequency.

2. The lower limit shall apply at the transition frequencies.

3. The limit decreases in line with the logarithm of the frequency in the rang of 0.15 to 0.50 MHz.

### 6.2 Test Setup

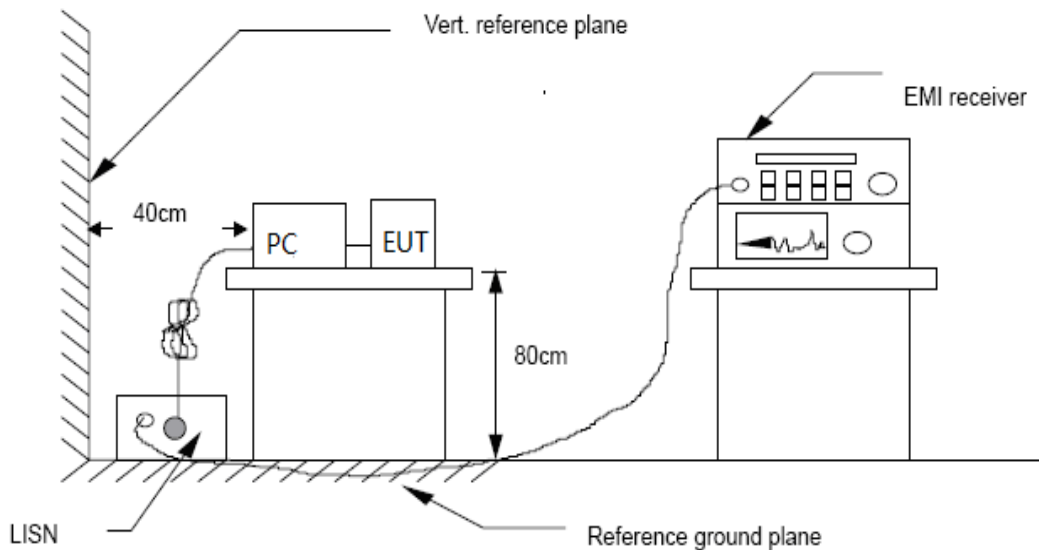

### 6.3 Test Procedure

The EUT is put on the plane 0.8m high above the ground by insulating support and is connected to the power mains through a line impedance stabilization network (L.I.S.N.). This provides a 50ohm coupling impedance for the EUT system. Please refer the block diagram of the test setup and photographs. Both sides of AC lines are checked to find out the maximum conducted emission. In order to find the maximum emission levels, the relative positions of equipment and all of the interface cables shall be changed according to ANSI C63.4-2009 on Conducted Emission Measurement. The bandwidth of test receiver (R & S ESCS30) is set at 9 kHz.

### 6.4 Test Results

PASS. (See below detailed test data)



Data: 13 File: E:\TEST REPORT\AI GUO SHI\Conduction 0.15-30.EM6 (16)

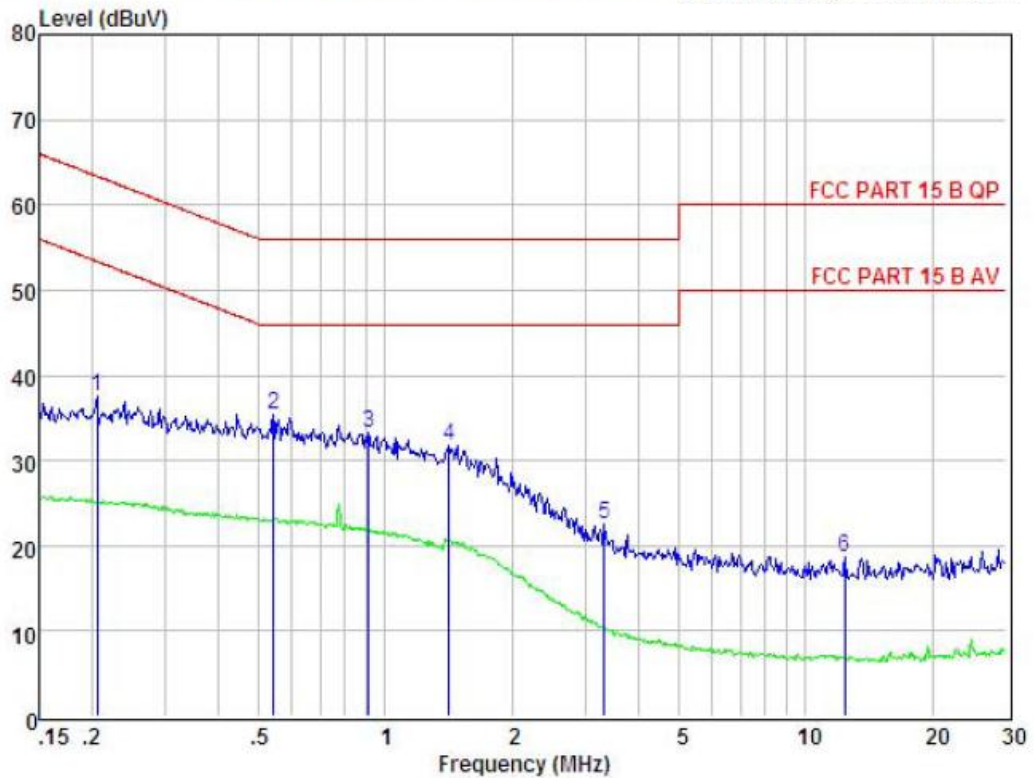

Condition : FCC PART 15 B QP POL: LINE Temp:20.1 °C Hum:45 %  
 EUI :  
 Model No : LMS for E-mount  
 Test Mode : Charging and TX mode, 2405MHz  
 Power : DC 5V from PC with AC 120V/60Hz  
 Test Engineer:  
 Remark :

Item	Freq MHz	Read dBuV	LISN Factor dB	Preamp Factor dB	Cable Loss dB	Level dBuV	Limit dBuV	Margin dBuV	Remark
1	0.206	27.58	0.03	-9.72	0.10	37.43	63.36	-25.93	Peak
2	0.541	25.57	0.03	-9.72	0.10	35.42	56.00	-20.58	Peak
3	0.914	23.45	0.04	-9.71	0.10	33.30	56.00	-22.70	Peak
4	1.418	21.90	0.05	-9.71	0.10	31.76	56.00	-24.24	Peak
5	3.328	12.54	0.08	-9.69	0.12	22.43	56.00	-33.57	Peak
6	12.384	8.79	0.25	-9.45	0.22	18.71	60.00	-41.29	Peak

Remarks: Level = Read + LISN Factor - Preamp Factor + Cable loss

Data: 15 File: E:\TEST REPORT\AI GUO SHI\Conduction 0.15-30.EM6 (16) Date: 2015-03-24 Time: 11:33:51

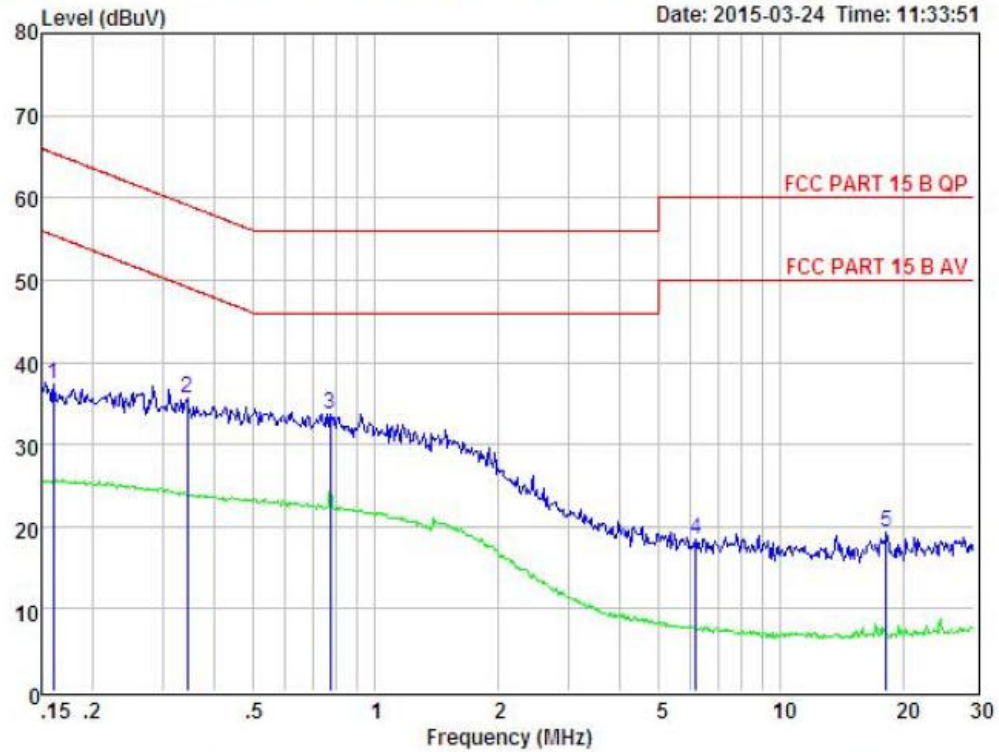

Condition : FCC PART 15 B QP POL: NEUTRAL Temp:20.1 °C Hum:45 %  
 EUI :  
 Model No : DEC for E-mount  
 Test Mode : Charging and TX mode, 2405MHz  
 Power : DC 5V from PC with AC 120V/60Hz  
 Test Engineer:  
 Remark :

Item	Freq MHz	Read dBuV	LISN Factor dB	Preamp Factor dB	Cable Loss dB	Level dBuV	Limit dBuV	Margin dBuV	Remark
1	0.161	27.53	0.03	-9.72	0.10	37.38	65.43	-28.05	Peak
2	0.343	25.72	0.03	-9.72	0.10	35.57	59.13	-23.56	Peak
3	0.775	23.92	0.00	-9.71	0.10	33.73	56.00	-22.27	Peak
4	6.186	8.69	0.11	-9.60	0.14	18.54	60.00	-41.46	Peak
5	18.232	9.31	0.29	-9.45	0.32	19.37	60.00	-40.63	Peak

Remarks: Level = Read + LISN Factor - Preamp Factor + Cable loss

## 7 Bandwidth

### 7.1 Test limit

Please refer section 15.249

### 7.2 Method of measurement

- a) The bandwidth is measured at an amplitude level reduced 20dB from the reference level. The reference level is the level of the highest amplitude signal observed from the transmitter at the fundamental frequency. Once the reference level is established, the equipment is conditioned with typical modulating signal to produce the worst-case (i.e. the widest) bandwidth.
- b) The test receiver RBW set 100KHz, VBW set 300KHz, Sweep time set auto.

### 7.3 Test Setup

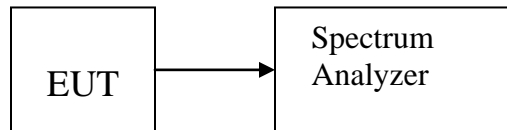

### 7.4 Test Results

PASS.

Detailed information please see the following page.

Channel	Frequency (MHz)	20dB Bandwidth (MHz)	Limit (KHz)	Result
CH1	2405	1.159	/	PASS
CH46	2427.5	1.138	/	PASS
CH91	2450	1.158	/	PASS

CH Low :

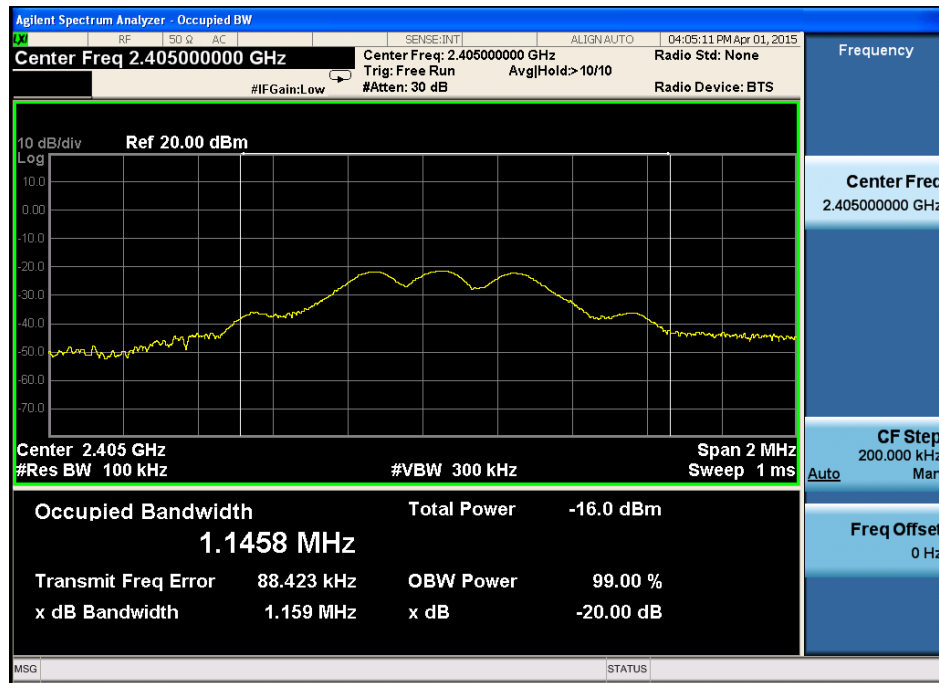

CH Mid :

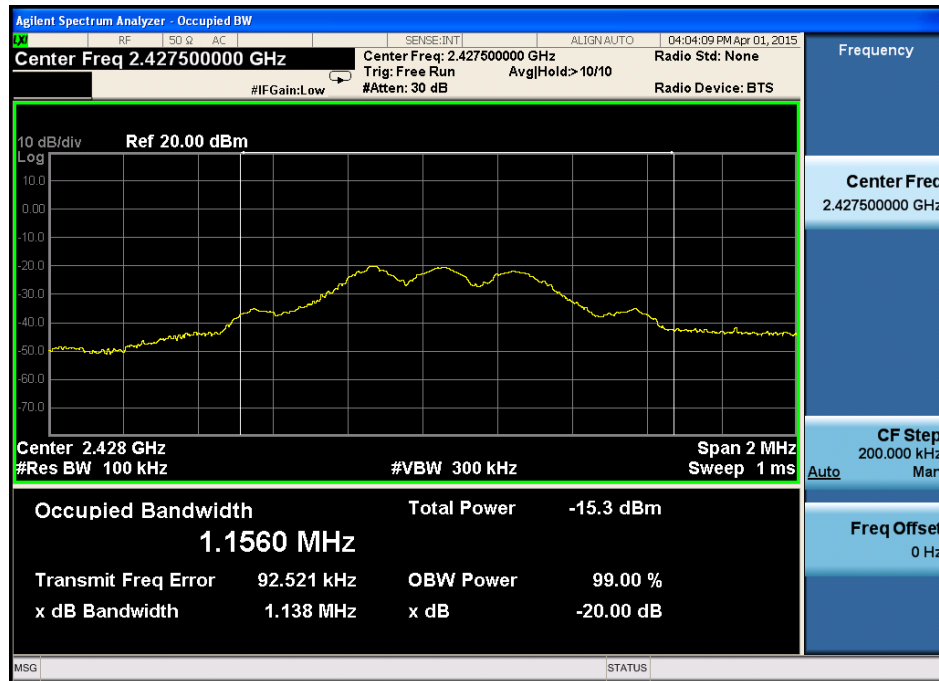

CH High :

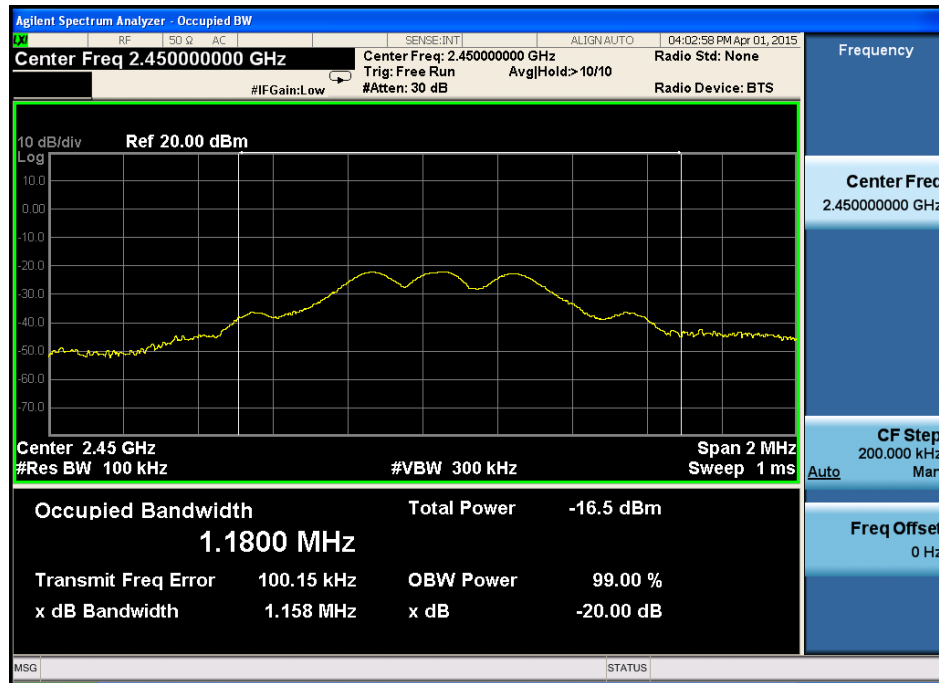

## 8 Band Edge Check

### 8.1 Test limit

Please refer section 15.249 and section 15.205.

249(d) Emissions radiated outside of the specified frequency bands, except for harmonics, shall be attenuated by at least 50 dB below the level of the fundamental or to the general radiated emission limits in section 15.209, whichever is the lesser attenuation. 249(e) As show in section 15.35(b), for frequencies above 1000MHz, the above field strength limits in paragraphs (a) and (b) of this section are based on average limits. However, the peak field strength of any emission shall not exceed the maximum permitted average limits specified above by more than 20 dB under any condition of modulation. For point-to-point operation under paragraph (b) of this section, the peak filed strength shall not exceed 2500 millivolts/meter at 3meters along the antenna azimuth.

### 8.2 Test Procedure

12.2.1 Put the EUT on a 0.8m high table, power on the EUT. Emissions were scanned and measured rotating the EUT to 360 degrees, Find the maximum Emission

12.2.2 Check the spurious emissions out of band.

12.2.3 RBW, VBW Setting, please see the following test plot.

### 8.3 Test Setup

Same as 5.2.2.

### 8.4 Test Result

PASS.

CH LOW :

2405MHz									
Fre. MHz	Plority H/V	Reading dBuV	Antenna Factor dB	Cable Loss dB	Amplifier Gain dB	Measure Result dBuV/m	Limit dBuV/m	Margin dB	Detector (PK/AV/ QP)
2390	H	45.26	27.62	3.92	34.97	41.83	74	32.17	PK
2390	H	--	27.62	3.94	34.97	--	54	--	AV
2400	H	47.16	27.62	3.94	34.97	43.75	74	30.25	PK
2400	H	--	27.62	3.94	34.97	--	54	--	AV
2390	V	46.72	27.62	3.92	34.97	43.29	74	30.71	PK
2390	V	--	27.62	3.94	34.97	--	54	--	AV
2400	V	48.29	27.62	3.94	34.97	44.88	74	29.12	PK
2400	V	--	27.62	3.94	34.97	--	54	--	AV

CH High :

2450MHz									
Fre. MHz	Plority H/V	Reading dBuV	Antenna Factor dB	Cable Loss dB	Amplifier Gain dB	Measure Result dBuV/m	Limit dBuV/m	Margin dB	Detector (PK/AV/ QP)
2483.5	H	43.19	27.89	4	34.97	40.11	74	33.89	PK
2483.5	H	--	27.89	4	34.97	--	54	--	AV
2483.5	V	44.51	27.89	4	34.97	41.43	74	32.57	PK
2483.5	V	--	27.89	4	34.97	--	54	--	AV

**Notes:** AV Means AV detector test data, Peak Means Peak detector test data.

## 9 Antenna Requirement

### 9.1 Standard Requirement

An intentional radiator shall be designed to ensure that no antenna other than that furnished by the responsible party shall be used with the device. The use of a permanently attached antenna or of an antenna that uses a unique coupling to the intentional radiator shall be considered sufficient to comply with the provisions of this Section. The manufacturer may design the unit so that a broken antenna can be replaced by the user, but the use of a standard antenna jack or electrical connector is prohibited.

### 9.2 Antenna Connected Construction

The directional gains of antenna used for transmitting is 0dBi, and de-signed with ipexconnector and no consideration of replacement. Please see EUT photo for details.

### 9.3 Result

The EUT antenna is PCB antenna connected to main board by cable with ipexconnector. It comply with the standard requirement.



## 10 Photographs of Test Setup

### 4.7 Photos of Radiated emission

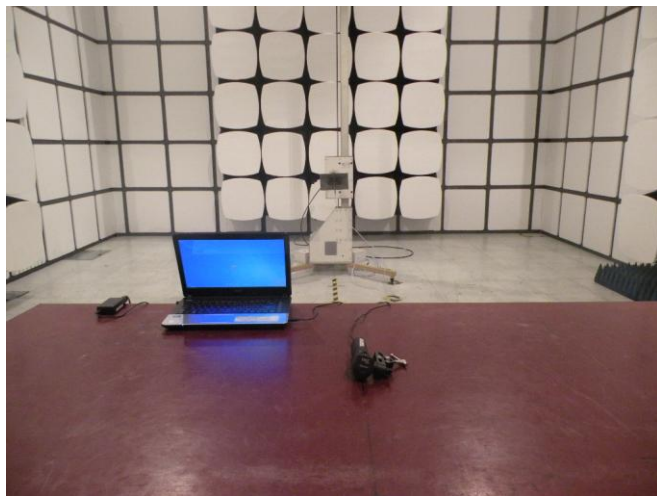
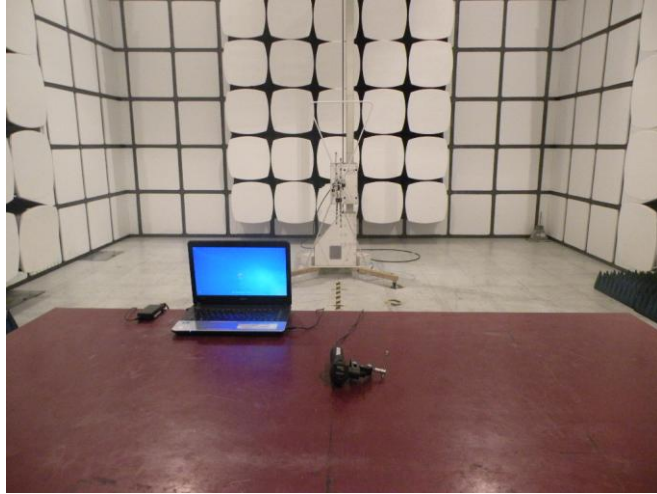

#### 4.8 Photos of Conducted Emission test

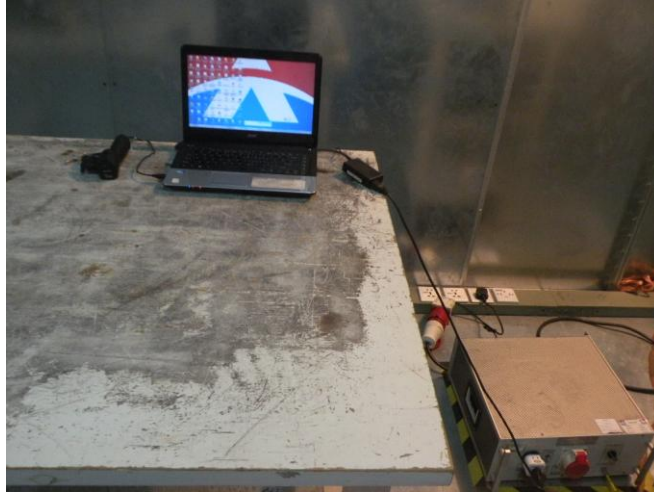

## 11 Photographs of EUT







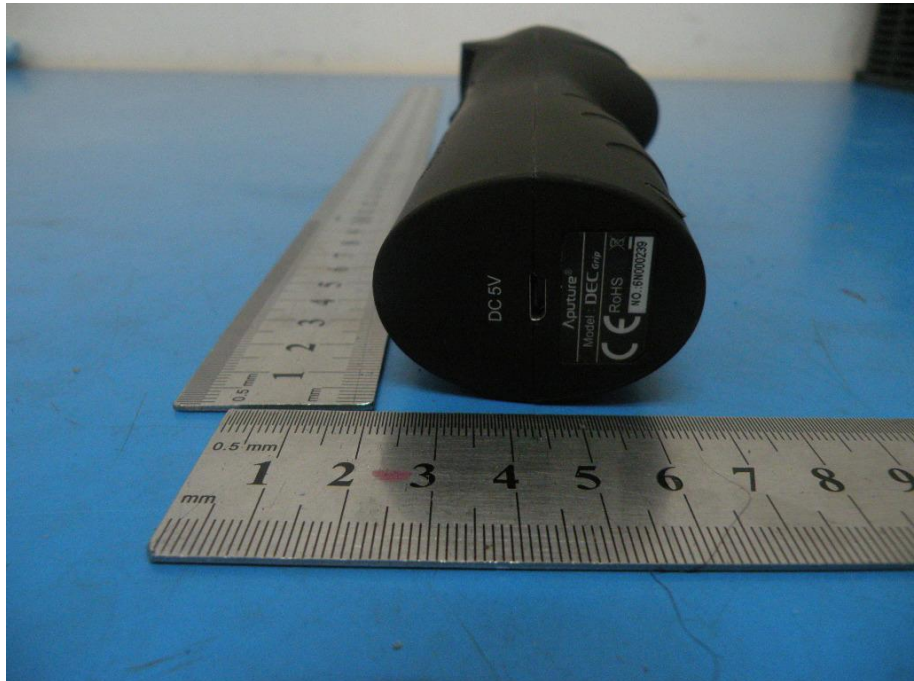

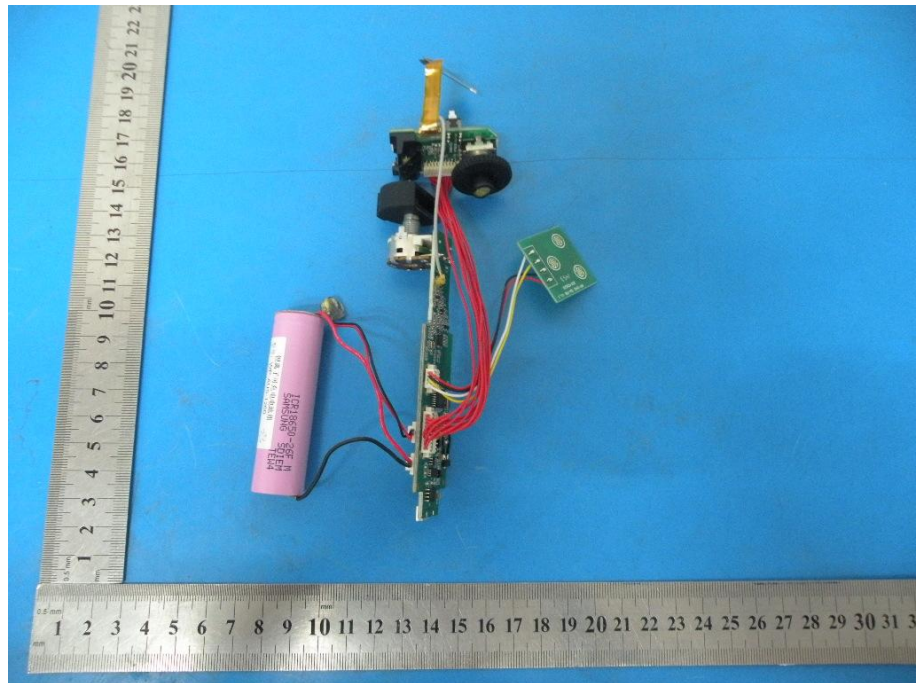
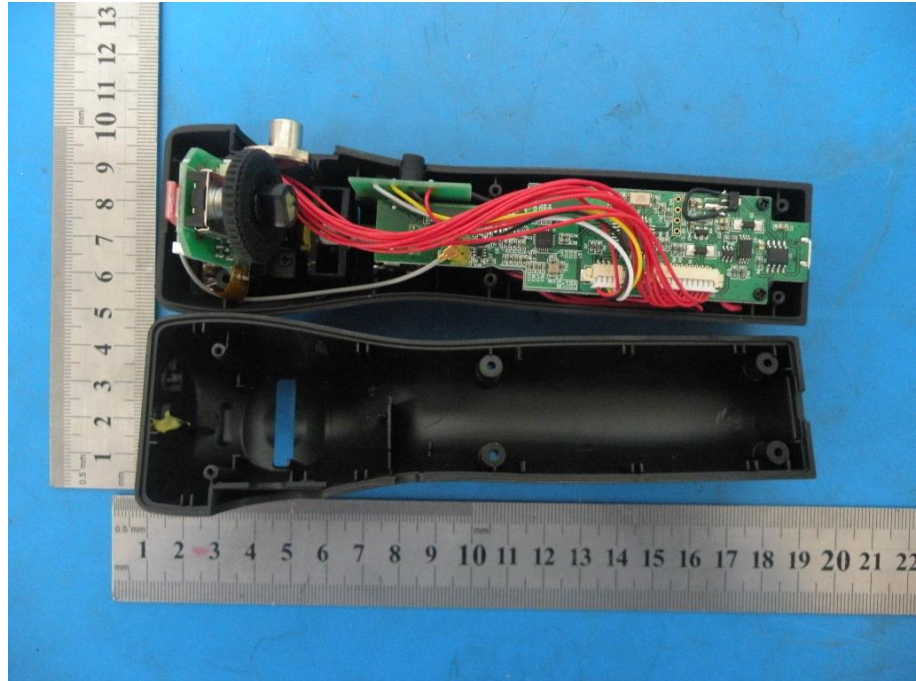



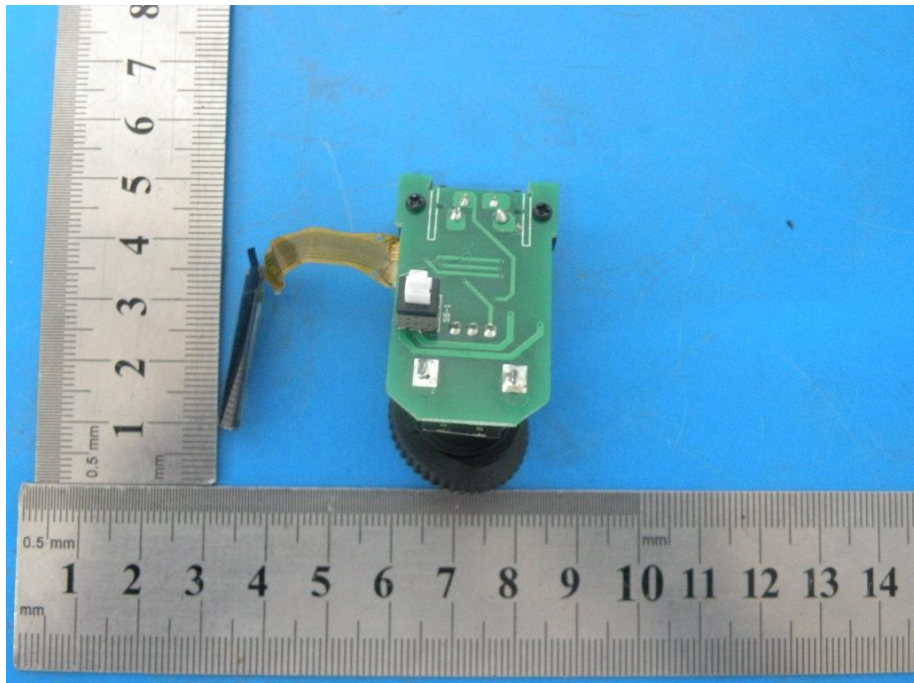
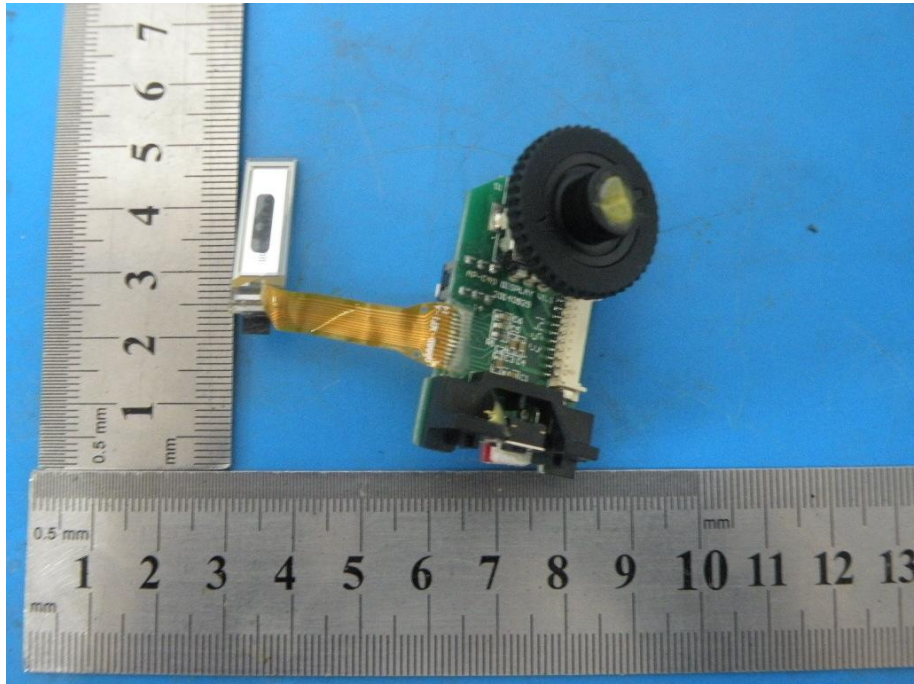

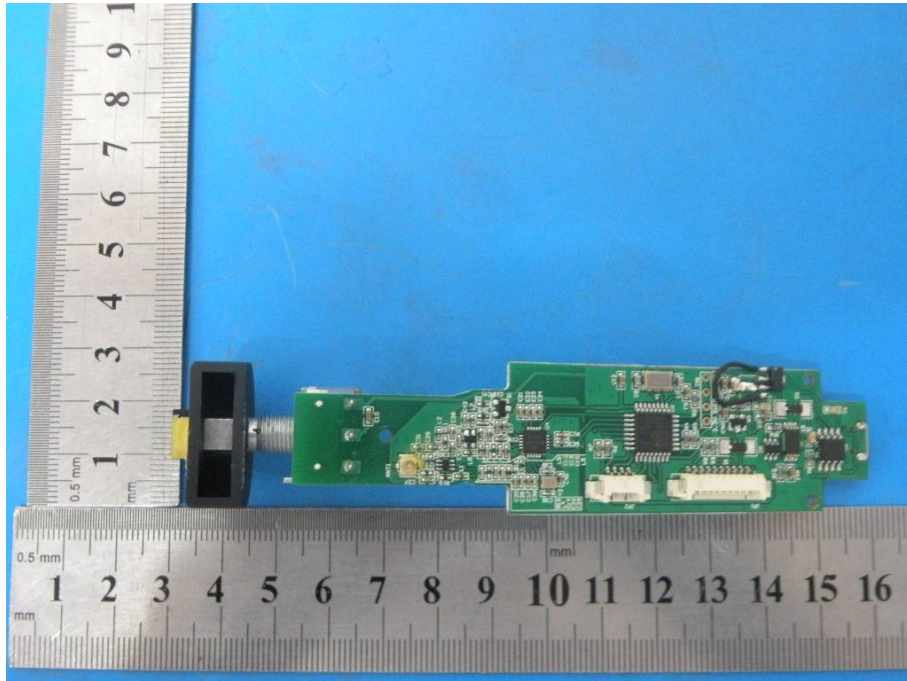
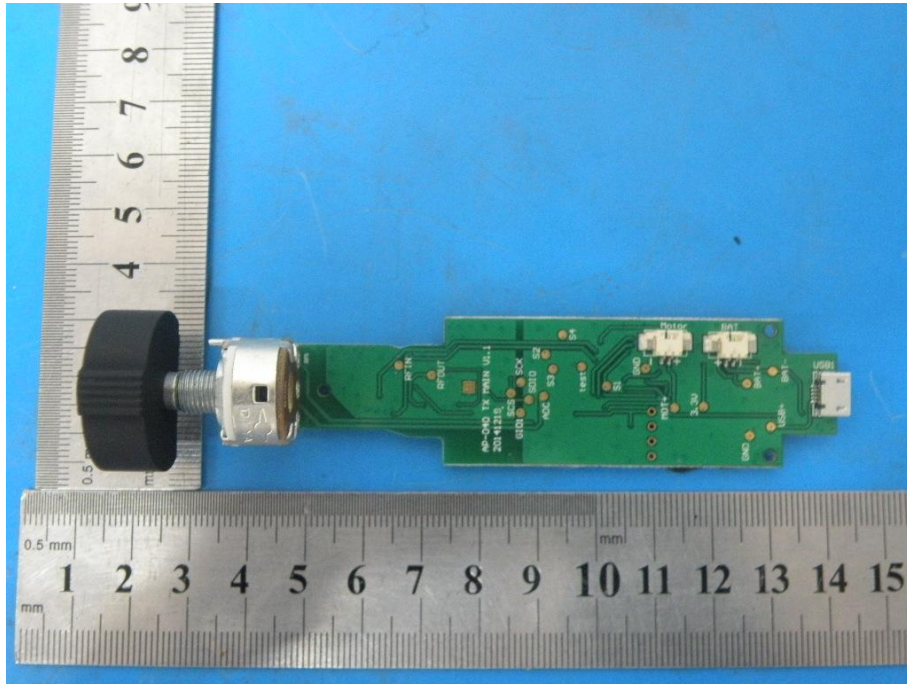



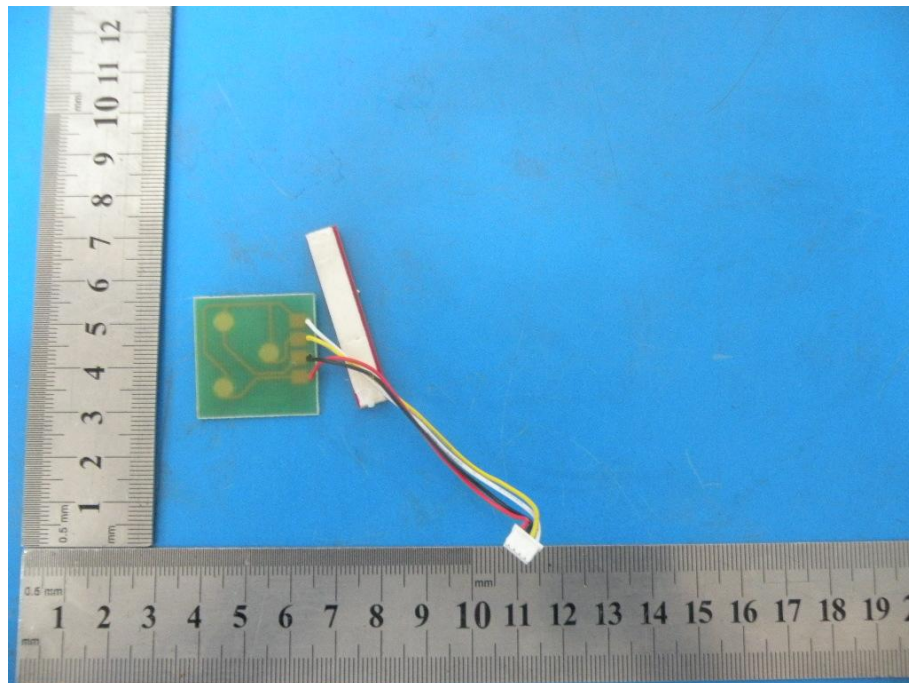
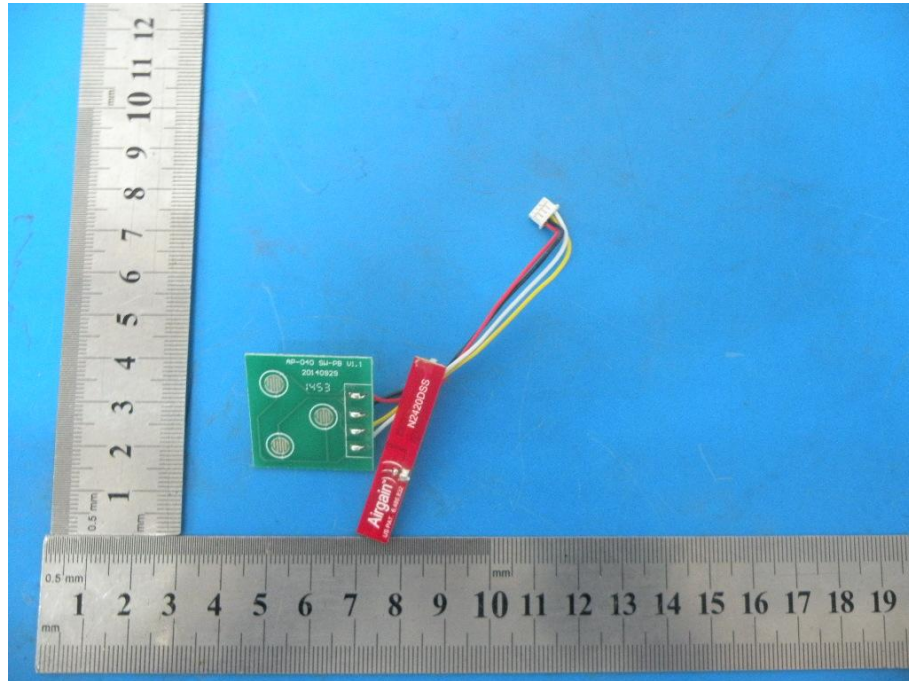

-----THE END OF REPORT-----