

FCC TEST REPORT
for
Aputure Imaging Industries Co., Ltd

DEC Vari-ND adapter
Model No.: DEC Vari-ND adapter

Prepared for : Aputure Imaging Industries Co., Ltd
Address : 3rd Floor, Building 21, Longjun Industrial Estate, Longhua,
Bao'an, Shenzhen, P.R.China

Prepared By : Shenzhen Anbotek Compliance Laboratory Limited
Address : 1/F., Building 1, SEC Industrial Park, No.0409 Qianhai Road,
Nanshan District, Shenzhen, Guangdong, China
Tel: (86) 755-26066544
Fax: (86) 755-26014772

Report Number : R0217030011W
Date of Test : Mar. 03~30, 2017
Date of Report : Mar. 30, 2017

TABLE OF CONTENTS

Description

Page

Test Report

1. GENERAL INFORMATION.....	5
1.1. Description of Device (EUT).....	5
1.2. Auxiliary Equipment Used during Test.....	6
1.3. Description of Test Facility.....	6
1.4. Measurement Uncertainty.....	6
1.5. List of channels.....	6
2. TEST METHODOLOGY.....	8
2.1. Summary of Test Results.....	8
2.2. Description of Test Modes.....	8
3. TEST PROCEDURE.....	9
4. Conducted Emission.....	10
4.1 Block Diagram of Test Setup.....	10
4.2 Power Line Conducted Emission Measurement Limits (15.207).....	10
4.3 Configuration of EUT on Measurement.....	10
4.4 Operating Condition of EUT.....	10
4.5 Test Procedure.....	11
4.6 Power Line Conducted Emission Measurement Results.....	11
5. RADIATION INTERFERENCE.....	16
5.1. Requirements (15.249, 15.209):.....	16
5.2. Test Procedure.....	16
5.3 Test Equipment.....	17
5.4. Test Results.....	17
6. BANDEDGE.....	23
6.1. Requirements (15.249):.....	23
6.2. Test Procedure.....	23
6.3. Test Configuration:.....	23
6.4. Test Results.....	24
7. OCCUPIED BANDWIDTH.....	33
7.1. Requirements :.....	33
7.2. Test SET-UP.....	33
7.3 Test Equipment.....	33
7.4. Test Results.....	33
8. ANTENNA APPLICATION.....	36
8.1. Antenna requirement.....	36

8.2. Result.....	36
9. PHOTOGRAPH.....	37
9.1 Photo of Power Line Conducted Emission Measurement.....	37
9.2 Photo of Radiation Emission Test.....	37
APPENDIX I (EXTERNAL PHOTOS).....	39
APPENDIX II (INTERNAL PHOTOS).....	42

Anbotek

TEST REPORT

Applicant : Aputure Imaging Industries Co., Ltd
Manufacturer : Aputure Imaging Industries Co., Ltd
EUT : DEC Vari-ND adapter
Model No. : DEC Vari-ND adapter
Serial No. : N.A.
Trade Mark : 
Rating : Input DC 5V (Battery Inside DC 3.7V, 1400mAh)

Measurement Procedure Used:

FCC Part15 Subpart C, Paragraph 15.207, 15.249 & 15.209

The device described above is tested by Shenzhen Anbotek Compliance Laboratory Limited to determine the maximum emission levels emanating from the device and the severe levels of the device can endure and its performance criterion. The measurement results are contained in this test report and Shenzhen Anbotek Compliance Laboratory Limited is assumed full of responsibility for the accuracy and completeness of these measurements. Also, this report shows that the EUT (Equipment Under Test) is technically compliant with the FCC Part 15 Subpart C requirements.

This report applies to above tested sample only and shall not be reproduced in part without written approval of Shenzhen Anbotek Compliance Laboratory Limited.

Date of Test : Mar. 03~30, 2017

Kyle Xu

Prepared by :  (Tested Engineer / Kyle Xu)

Brown Lu

Reviewer : (Project Manager / Brown Lu)

Tom Chen

Approved & Authorized Signer : (Manager / Tom Chen)

1. GENERAL INFORMATION

1.1. Description of Device (EUT)

EUT : DEC Vari-ND adapter

Model Number : DEC Vari-ND adapter

Test Power Supply : AC 120V, 60Hz / AC 240V, 60Hz
DC 3.7V Battery

Frequency : 2402~2479.5MHz

No. of Channels : 156 Channels, 500kHz Spacing

Antenna Specification : PCB Antenna: 2 dBi

Applicant : Aputure Imaging Industries Co., Ltd
Address : 3rd Floor, Building 21, Longjun Industrial Estate, Longhua, Bao'an, Shenzhen, P.R.China

Manufacturer : Aputure Imaging Industries Co., Ltd
Address : 3rd Floor, Building 21, Longjun Industrial Estate, Longhua, Bao'an, Shenzhen, P.R.China

Date of receipt : Mar. 03, 2017

Date of Test : Mar. 03~30, 2017

1.2. Auxiliary Equipment Used during Test

Adapter : Manufacturer: ZTE
 M/N: STC-A2050I1000USBA-C
 S/N: 201202102100876
 Input: 100-240V~50/60Hz 0.3A
 Output: DC 5V, 1000mA

1.3. Description of Test Facility

The test facility is recognized, certified, or accredited by the following organizations:

FCC-Registration No.: 752021

Shenzhen Anbotek Compliance Laboratory Limited, EMC Laboratory has been registered and fully described in a report filed with the (FCC) Federal Communications Commission. The acceptance letter from the FCC is maintained in our files. Registration 752021, July 06, 2016.

IC-Registration No.: 8058A-1

Shenzhen Anbotek Compliance Laboratory Limited., EMC Laboratory has been registered and fully described in a report filed with the (IC) Industry Canada. The acceptance letter from the IC is maintained in our files. Registration 8058A, June 13, 2016.

Test Location

All Emissions tests were performed at Shenzhen Anbotek Compliance Laboratory Limited. at 1/F., Building 1, SEC Industrial Park, No.0409 Qianhai Road, Nanshan District, Shenzhen, Guangdong, China

1.4. Measurement Uncertainty

Radiation Uncertainty : Ur = 4.1 dB (Horizontal)
 Ur = 4.3 dB (Vertical)
 Conduction Uncertainty : Uc = 3.4dB

1.5. List of channels

Channel	Freq. (MHz)	Channel	Freq. (MHz)	Channel	Freq. (MHz)	Channel	Freq. (MHz)
1	2402.00	41	2422.00	81	2442.00	121	2462.00
2	2402.50	42	2422.50	82	2442.50	122	2462.50
3	2403.00	43	2423.00	83	2443.00	123	2463.00
4	2403.50	44	2423.50	84	2443.50	124	2463.50

5	2404.00	45	2424.00	85	2444.00	125	2464.00
6	2404.50	46	2424.50	86	2444.50	126	2464.50
7	2405.00	47	2425.00	87	2445.00	127	2465.00
8	2405.50	48	2425.50	88	2445.50	128	2465.50
9	2406.00	49	2426.00	89	2446.00	129	2466.00
10	2406.50	50	2426.50	90	2446.50	130	2466.50
11	2407.00	51	2427.00	91	2447.00	131	2467.00
12	2407.50	52	2427.50	92	2447.50	132	2467.50
13	2408.00	53	2428.00	93	2448.00	133	2468.00
14	2408.50	54	2428.50	94	2448.50	134	2468.50
15	2409.00	55	2429.00	95	2449.00	135	2469.00
16	2409.50	56	2429.50	96	2449.50	136	2469.50
17	2410.00	57	2430.00	97	2450.00	137	2470.00
18	2410.50	58	2430.50	98	2450.50	138	2470.50
19	2411.00	59	2431.00	99	2451.00	139	2471.00
20	2411.50	60	2431.50	100	2451.50	140	2471.50
21	2412.00	61	2432.00	101	2452.00	141	2472.00
22	2412.50	62	2432.50	102	2452.50	142	2472.50
23	2413.00	63	2433.00	103	2453.00	143	2473.00
24	2413.50	64	2433.50	104	2453.50	144	2473.50
25	2414.00	65	2434.00	105	2454.00	145	2474.00
26	2414.50	66	2434.50	106	2454.50	146	2474.50
27	2415.00	67	2435.00	107	2455.00	147	2475.00
28	2415.50	68	2435.50	108	2455.50	148	2475.50
29	2416.00	69	2436.00	109	2456.00	149	2476.00
30	2416.50	70	2436.50	110	2456.50	150	2476.50
31	2417.00	71	2437.00	111	2457.00	151	2477.00
32	2417.50	72	2437.50	112	2457.50	152	2477.50
33	2418.00	73	2438.00	113	2458.00	153	2478.00
34	2418.50	74	2438.50	114	2458.50	154	2478.50
35	2419.00	75	2439.00	115	2459.00	155	2479.00
36	2419.50	76	2439.50	116	2459.50	156	2479.50
37	2420.00	77	2440.00	117	2460.00	157	
38	2420.50	78	2440.50	118	2460.50	158	
39	2421.00	79	2441.00	119	2461.00	159	
40	2421.50	80	2441.50	120	2461.50	160	

2. TEST METHODOLOGY

The tests documented in this report were performed in accordance with ANSI C63.10: 2013 and FCC Part 15, Paragraph 15.249.

2.1. Summary of Test Results

The EUT has been tested according to the following specifications:

Standard	Test Type	Result	Notes
§15.207 (a)	Conducted Emission	PASS	Complies
§15.205	Restricted Band of Operation	PASS	Complies
§15.209 §15.249(a)	Radiated Emission	PASS	Complies
§15.215(c)	20dB Bandwidth Test	PASS	Complies
§15.203	Antenna Requirement	PASS	Complies

2.2. Description of Test Modes

The EUT has been tested under operating condition.

Manual control the EUT for staying in continuous transmitting mode.

Channel Low(2402MHz), Channel Middle(2440MHz) and Channel High(2479.5MHz) are chosen for the final testing.

3. Test Procedure

GENERAL: This report shall NOT be reproduced except in full without the written approval of Shenzhen Anbotek Compliance Laboratory Limited. The EUT was transmitting a test signal during the testing.

RADIATION INTERFERENCE: The test procedure used was ANSI STANDARD C63.10-2013 using a spectrum analyzer with a pre-selector. The analyzer was calibrated in dB above a microvolt at the output of the antenna. The resolution bandwidth was 100KHz and the video bandwidth was 300KHz up to 1.0GHz and 1.0MHz with a video BW of 3.0MHz above 1.0GHz. The ambient temperature of the EUT was 74.3oF with a humidity of 69%.

FORMULA OF CONVERSION FACTORS: The Field Strength at 3m was established by adding the meter reading of the spectrum analyzer (which is set to read in units of dBuV) to the antenna correction factor supplied by the antenna manufacturer. The antenna correction factors are stated in terms of dB. The gain of the Preselector was accounted for in the Spectrum Analyzer Meter Reading.

Example:

Freq (MHz) METER READING + ACF = FS
20 dBuV + 10.36 dB = 30.36 dBuV/m @ 3m

ANSI STANDARD C63.10-2013 10.1.7 MEASUREMENT PROCEDURES: The EUT was placed on a table 80 cm high and with dimensions of 1m by 1.5m. The EUT was placed in the center of the table (1.5m side). The table used for radiated measurements is capable of continuous rotation.

When an emission was found, the table was rotated to produce the maximum signal strength. At this point, the antenna was raised and lowered from 1m to 4m. The antenna was placed in both the horizontal and vertical planes.

4. Conducted Emission

4.1 Block Diagram of Test Setup

4.1.1. Block diagram of connection between the EUT and simulators

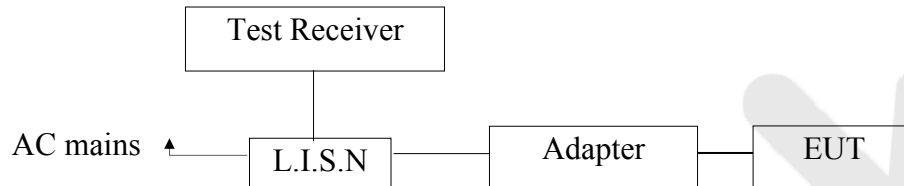

4.2 Power Line Conducted Emission Measurement Limits (15.207)

Frequency MHz	Limits dB(μV)	
	Quasi-peak Level	Average Level
0.15 ~ 0.50	66 ~ 56*	56 ~ 46*
0.50 ~ 5.00	56	46
5.00 ~ 30.00	60	50

- Notes: 1. *Decreasing linearly with logarithm of frequency.
2. The lower limit shall apply at the transition frequencies.

4.3 Configuration of EUT on Measurement

The following equipments are installed on Power Line Conducted Emission Measurement to meet the commission requirement and operating regulations in a manner which tends to maximize its emission characteristics in a normal application.

4.4 Operating Condition of EUT

- 4.4.1. Setup the EUT and simulator as shown as Section 4.1.
- 4.4.2. Turn on the power of all equipment.
- 4.4.3. Let the EUT work in test mode (Charge Mode) and measure it.

4.5 Test Procedure

The EUT system is connected to the power mains through a line impedance stabilization network (L.I.S.N.). This provides a 50ohm coupling impedance for the EUT system. Please refer the block diagram of the test setup and photographs. Both sides of AC line are checked to find out the maximum conducted emission. In order to find the maximum emission levels, the relative positions of equipment and all of the interface cables shall be changed according to FCC ANSI C63.10-2013 on Conducted Emission Measurement.

The bandwidth of test receiver (ESCI) set at 9KHz.

The frequency range from 150KHz to 30MHz is checked.

The test results are reported on Section 4.6.

Test Equipment

Item	Equipment	Manufacturer	Model No.	Serial No.	Last Cal.	Cal. Interval
1.	Two-Line V-network	Rohde & Schwarz	ENV216	100055	Jul. 19, 2016	1 Year
2.	EMI Test Receiver	Rohde & Schwarz	ESCI	100627	Jun. 17, 2016	1 Year
3.	RF Switching Unit	Compliance Direction	RSU-M2	38303	Jun. 17, 2016	1 Year

4.6 Power Line Conducted Emission Measurement Results

PASS.

The frequency range from 150KHz to 30 MHz is investigated.

Please to see the following pages

CONDUCTED EMISSION TEST DATA

Test Site: 1# Shielded Room
 Operating Condition: Charge Mode
 Test Specification: AC 120V, 60Hz for adapter
 Comment: Live Line
 Tem.:25°C Hum.:50%

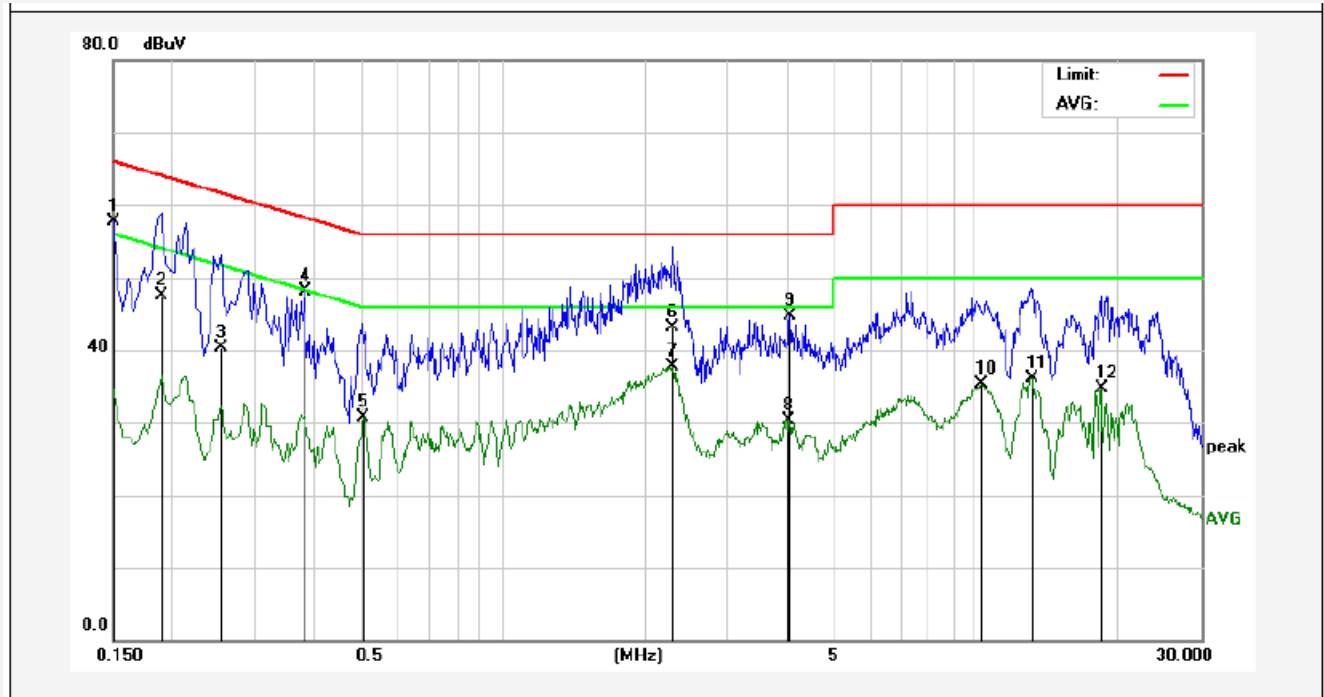

No.	Freq. (MHz)	Reading (dBuV)	Factor (dB)	Result (dBuV)	Limit dBuV	Over Limit (dB)	Detector	Remark
1	0.1500	37.83	19.90	57.73	65.99	-8.26	QP	
2	0.1900	27.63	19.90	47.53	64.03	-16.50	QP	
3	0.2540	20.40	19.89	40.29	61.62	-21.33	QP	
4	0.3820	28.27	19.93	48.20	58.23	-10.03	QP	
5	0.5100	10.79	19.98	30.77	46.00	-15.23	AVG	
6	2.2900	22.95	20.15	43.10	56.00	-12.90	QP	
7	2.2900	17.59	20.15	37.74	46.00	-8.26	AVG	
8	4.0100	10.22	20.18	30.40	46.00	-15.60	AVG	
9	4.0500	24.59	20.18	44.77	56.00	-11.23	QP	
10	10.3420	14.96	20.33	35.29	50.00	-14.71	AVG	
11	13.1740	15.89	20.29	36.18	50.00	-13.82	AVG	
12	18.4380	14.35	20.31	34.66	50.00	-15.34	AVG	

CONDUCTED EMISSION TEST DATA

Test Site: 1# Shielded Room
 Operating Condition: Charge Mode
 Test Specification: AC 120V, 60Hz for adapter
 Comment: Neutral Line
 Tem.:25°C Hum.:50%

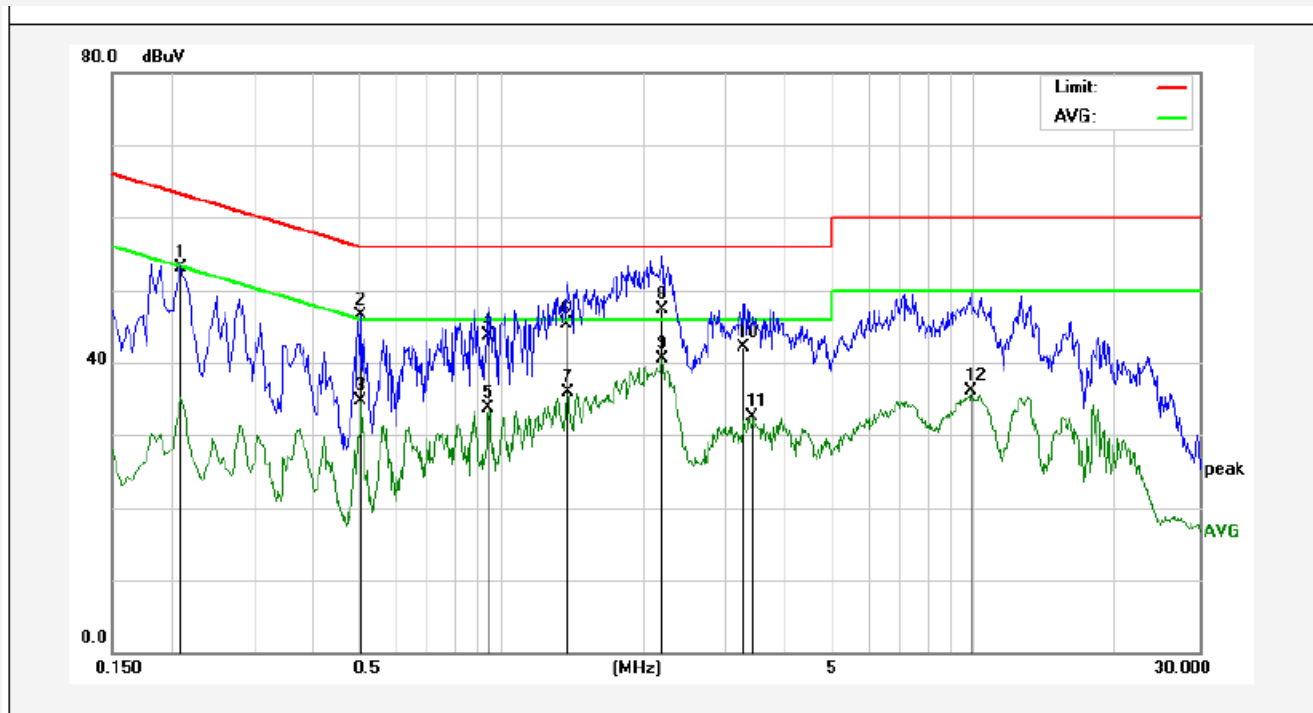

No.	Freq. (MHz)	Reading (dBuV)	Factor (dB)	Result (dBuV)	Limit dBuV	Over Limit (dB)	Detector	Remark
1	0.2100	33.30	19.90	53.20	63.20	-10.00	QP	
2	0.5060	26.47	19.98	46.45	56.00	-9.55	QP	
3	0.5060	14.64	19.98	34.62	46.00	-11.38	AVG	
4	0.9420	23.51	20.10	43.61	56.00	-12.39	QP	
5	0.9420	13.58	20.10	33.68	46.00	-12.32	AVG	
6	1.3740	25.17	20.13	45.30	56.00	-10.70	QP	
7	1.3860	15.79	20.13	35.92	46.00	-10.08	AVG	
8	2.1980	27.16	20.14	47.30	56.00	-8.70	QP	
9	2.1980	20.40	20.14	40.54	46.00	-5.46	AVG	
10	3.2620	21.98	20.17	42.15	56.00	-13.85	QP	
11	3.4100	12.35	20.17	32.52	46.00	-13.48	AVG	
12	9.8659	15.74	20.34	36.08	50.00	-13.92	AVG	

CONDUCTED EMISSION TEST DATA

Test Site: 1# Shielded Room
 Operating Condition: Charge Mode
 Test Specification: AC 240V, 60Hz for adapter
 Comment: Live Line
 Tem.:25°C Hum.:50%

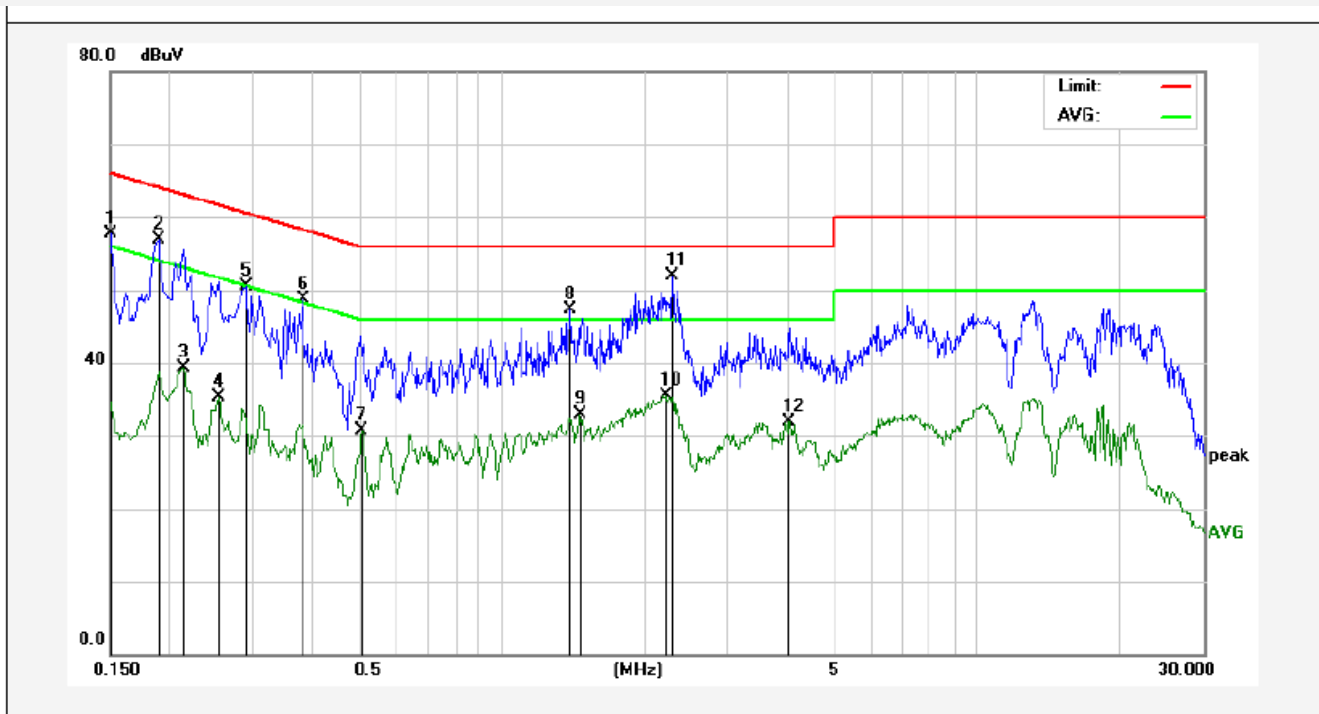

No.	Freq. (MHz)	Reading (dBuV)	Factor (dB)	Result (dBuV)	Limit dBuV	Over Limit (dB)	Detector	Remark
1	0.1499	37.83	19.90	57.73	66.00	-8.27	QP	
2	0.1900	36.93	19.90	56.83	64.03	-7.20	QP	
3	0.2139	19.49	19.90	39.39	53.05	-13.66	AVG	
4	0.2540	15.43	19.89	35.32	51.62	-16.30	AVG	
5	0.2899	30.58	19.89	50.47	60.52	-10.05	QP	
6	0.3820	28.77	19.93	48.70	58.23	-9.53	QP	
7	0.5100	10.79	19.98	30.77	46.00	-15.23	AVG	
8	1.4019	27.10	20.13	47.23	56.00	-8.77	QP	
9	1.4619	12.74	20.13	32.87	46.00	-13.13	AVG	
10	2.2139	15.46	20.14	35.60	46.00	-10.40	AVG	
11	2.2900	31.72	20.15	51.87	56.00	-4.13	QP	
12	4.0099	11.72	20.18	31.90	46.00	-14.10	AVG	

CONDUCTED EMISSION TEST DATA

Test Site: 1# Shielded Room
 Operating Condition: Charge Mode
 Test Specification: AC 240V, 60Hz for adapter
 Comment: Neutral Line
 Tem.:25°C Hum.:50%

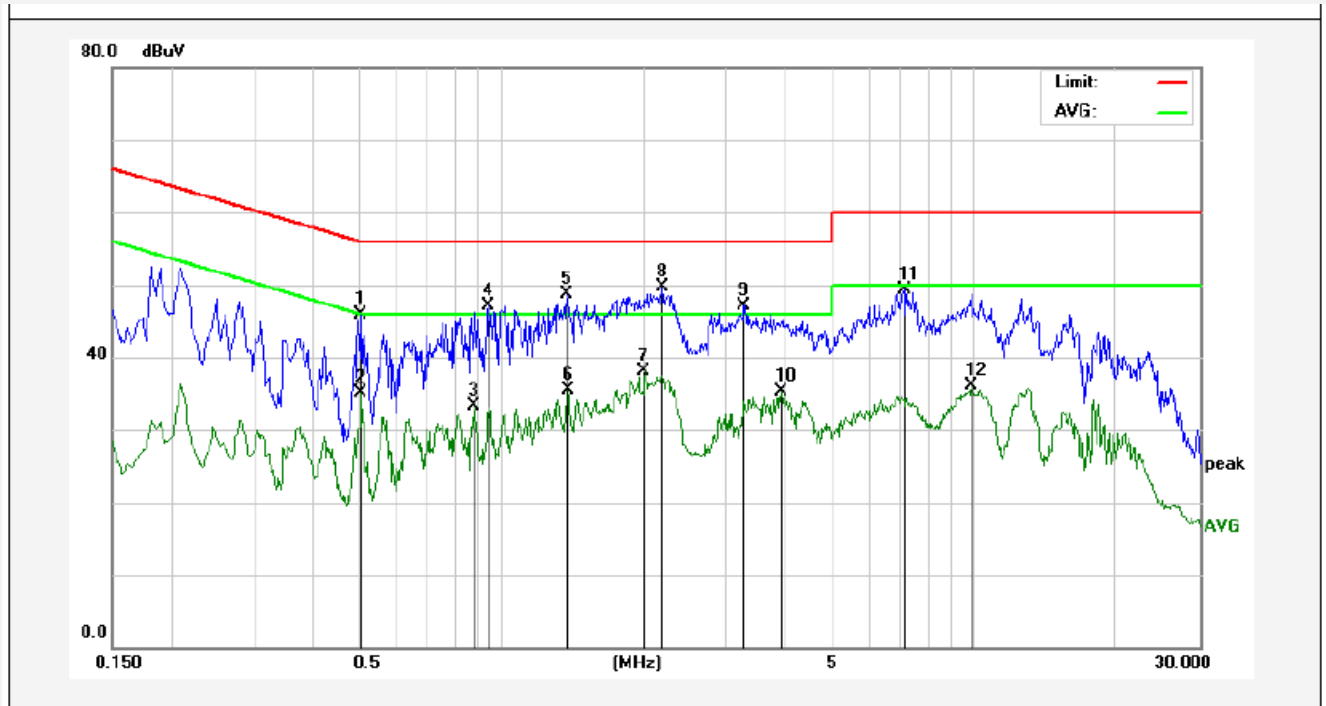

No.	Freq. (MHz)	Reading (dBuV)	Factor (dB)	Result (dBuV)	Limit dBuV	Over Limit (dB)	Detector	Remark
1	0.5060	25.97	19.98	45.95	56.00	-10.05	QP	
2	0.5060	15.14	19.98	35.12	46.00	-10.88	AVG	
3	0.8739	13.29	20.09	33.38	46.00	-12.62	AVG	
4	0.9417	27.10	20.10	47.20	56.00	-8.80	QP	
5	1.3740	28.51	20.13	48.64	56.00	-7.36	QP	
6	1.3857	15.29	20.13	35.42	46.00	-10.58	AVG	
7	2.0178	17.89	20.14	38.03	46.00	-7.97	AVG	
8	2.1979	29.49	20.14	49.63	56.00	-6.37	QP	
9	3.2620	26.98	20.17	47.15	56.00	-8.85	QP	
10	3.9100	15.08	20.18	35.26	46.00	-10.74	AVG	
11	7.1337	29.10	20.26	49.36	60.00	-10.64	QP	
12	9.8658	15.74	20.34	36.08	50.00	-13.92	AVG	

5. Radiation Interference

5.1. Requirements (15.249, 15.209):

FIELD STRENGTH of Fundamental: @3M	FIELD STRENGTH of Harmonics	S15.209	
902-928 MHZ		30 - 88 MHz	40 dBuV/m
2.4-2.4835 GHz		88 - 216 MHz	43.5
94 dB μ V/m @3m	54 dB μ V/m @3m	216 - 960 MHz	46
		ABOVE 960 MHz	54dBuV/m

Emissions radiated outside of the specified frequency bands, except for harmonics, shall be attenuated by at least 50 dB below the level of the fundamental or to the general radiated emission limits in 15.209, whichever is the lesser attenuation.

5.2. Test Procedure

For below 1GHz, the EUT is placed on a turn table which is 0.8 meter high above the ground. For above 1GHz, the EUT is placed on a turn table which is 1.5 meter high above the ground. The turn table can rotate 360 degrees to determine the position of the maximum emission level. The EUT is set 3 meters away from the receiving antenna which is mounted on a antenna tower. The antenna can be moved up and down from 1 to 4 meters to find out the maximum emission level. Both horizontal and vertical polarization of the antenna are set on test.

All readings from 30MHz to 1GHz are quasi-peak values with a resolution bandwidth of 120kHz. All reading are above 1GHz, peak & average values with a resolution bandwidth of 1MHz. The EUT is tested in 9*6*6 Chamber. The device is evaluated in xyz orientation. The test results are listed in Section 5.3.

5.3 Test Equipment

Item	Equipment	Manufacturer	Model No.	Serial No.	Last Cal.	Cal. Interval
1.	Two-Line V-network	Rohde & Schwarz	ENV216	100055	Jul. 19, 2016	1 Year
2.	EMI Test Receiver	Rohde & Schwarz	ESCI	100627	Jun. 17, 2016	1 Year
3.	RF Switching Unit	Compliance Direction	RSU-M2	38303	Jun. 17, 2016	1 Year
4.	Spectrum Analysis	Agilent	E4407B	US39390582	Jul. 12, 2016	1 Year
5	Preamplifier	Instruments corporation	EMC011830	980100	Jun. 17, 2016	1 Year
6.	EMI Test Receiver	Rohde & Schwarz	ESPI	101604	Jun. 17, 2016	1 Year
7.	Double Ridged Horn Antenna	Instruments corporation	GTH-0118	351600	May 06, 2016	1 Year
8.	Bilog Broadband Antenna	Schwarzbeck	VULB9163	VULB 9163-289	May 06, 2016	1 Year
9.	Loop Antenna	Schwarzbeck	FMZB 1519	012	May 11, 2016	1 Year
10.	Pre-amplifier	SONOMA	310N	186860	Jun. 17, 2016	1 Year
11	EMI Test Software EZ-EMC	SHURPLE	N/A	N/A	N/A	N/A
12.	Power Sensor	Agilent	KFSW150502	15I00041SN045	Jun. 17, 2016	1 Year
13.	MXA Spectrum Analysis	Agilent	N9020A	MY51170037	Jun. 17, 2016	1 Year
14.	MXG RF Vector Signal Generator	Agilent	N5182A	MY48180656	Jun. 17, 2016	1 Year
15	Signal Generator	Agilent	E4421B	MY41000743	Jun. 17, 2016	1 Year
16.	DC Power supply	IV	IV-8080	YQSB0096	Jun. 17, 2016	1 Year
17.	TEMP&HUMI PROGRAMMABLE CHAMBER	Bell Group	BE-THK-150M8	SE-0137	Jun. 17, 2016	1 Year

5.4. Test Results

PASS.

Please refer the following pages. Only the worst case (x orientation).

Below 1GHz:

Job No.:	0217030011W	Polarization:	Horizontal
Standard:	(RE)FCC PART15 C _3m	Power Source:	DC 3.7V Battery
Test item:	Radiation Test	Temp.(C)/Hum.(%RH):	24.3(C)/55%RH
Mode:	ON	Distance:	3m
Note:	30-1000MHz		

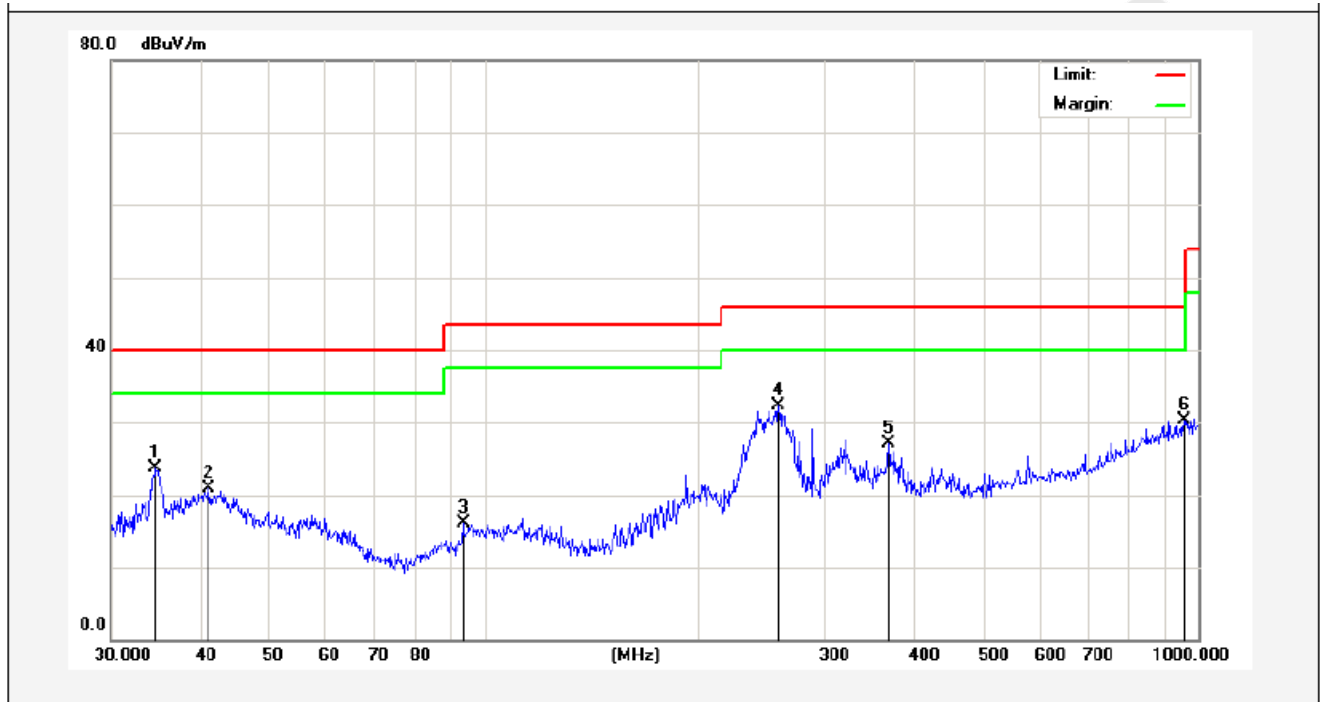

No.	Freq. (MHz)	Reading (dBuV/m)	Factor (dB/m)	Result (dBuV/m)	Limit (dBuV/)	Over Limit (dB)	Detector	Height (cm)	degree (deg)	Remark
1	34.6385	38.18	-14.49	23.69	40.00	-16.31	peak			
2	41.1320	31.63	-10.81	20.82	40.00	-19.18	peak			
3	93.4402	37.77	-21.60	16.17	43.50	-27.33	peak			
4	258.3264	51.14	-18.91	32.23	46.00	-13.77	peak			
5	368.1116	40.59	-13.50	27.09	46.00	-18.91	peak			
6	955.4381	34.14	-3.88	30.26	46.00	-15.74	peak			

Job No.:	0217030011W	Polarization:	Vertical
Standard:	(RE)FCC PART15 C_3m	Power Source:	DC 3.7V Battery
Test item:	Radiation Test	Temp.(C)/Hum.(%RH):	24.3(C)/55%RH
Mode:	ON	Distance:	3m
Note:	30-1000MHz		

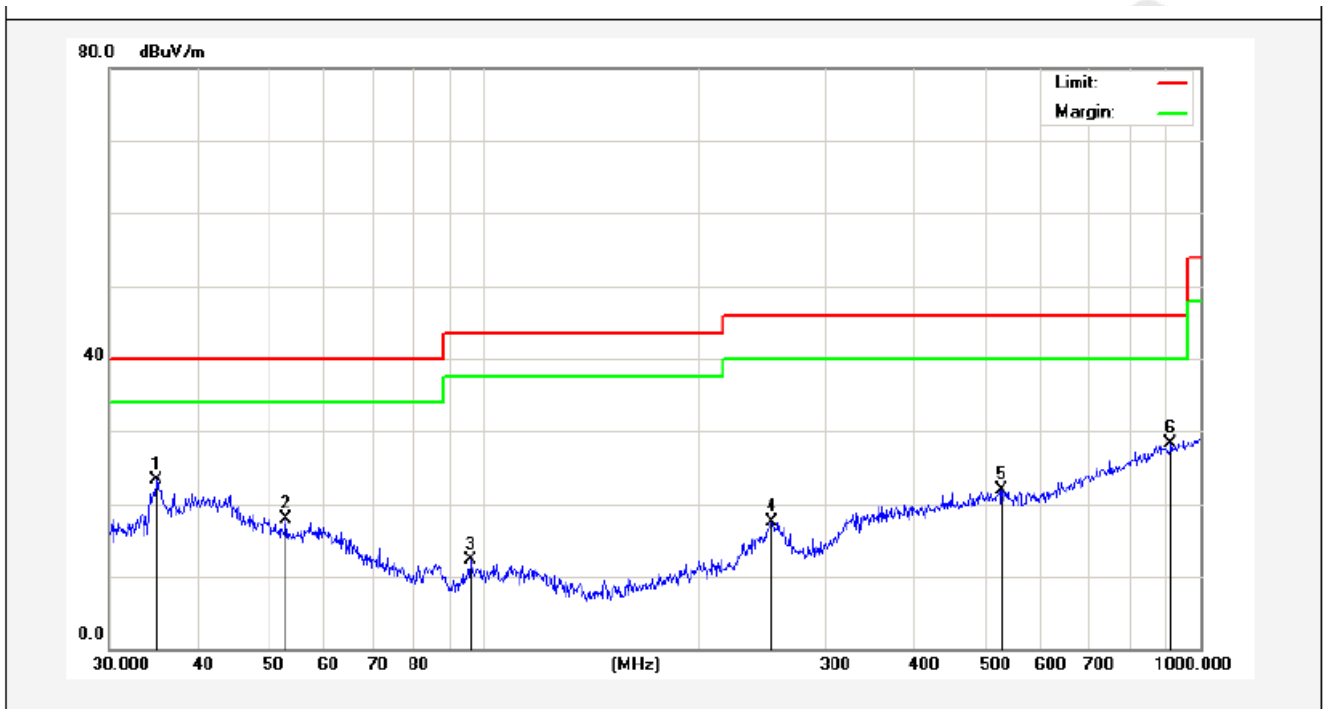

No.	Freq. (MHz)	Reading (dBuV/m)	Factor (dB/m)	Result (dBuV/m)	Limit (dBuV/)	Over Limit (dB)	Detector	Height (cm)	degree (deg)	Remark
1	34.8823	37.70	-14.35	23.35	40.00	-16.65	peak			
2	52.9453	32.75	-14.78	17.97	40.00	-22.03	peak			
3	95.7622	28.32	-15.98	12.34	43.50	-31.16	peak			
4	252.0627	31.59	-14.03	17.56	46.00	-28.44	peak			
5	528.2458	32.42	-10.47	21.95	46.00	-24.05	peak			
6	909.6667	31.85	-3.61	28.24	46.00	-17.76	peak			

Above 1 GHz:

Horizontal CH Low (2402MHz)								
Frequency MHz	Cable Loss dB	Ant Factor dB/m	Preamp Factor dB	Read Level dB μ V	Level dB μ V/m	Limit dB μ V/m	Over Limit dB	Remark
2402.000	2.17	31.21	35.30	85.32	83.40	114.0	-30.60	Peak
2402.000	2.17	31.21	35.30	78.24	76.32	94.0	-17.68	AV
4804.240	2.56	34.01	34.71	47.34	49.20	74.0	-24.80	Peak
4804.240	2.56	34.01	34.71	33.09	34.95	54.0	-19.05	AV
7206.380	2.98	36.16	35.15	40.12	44.11	74.0	-29.89	Peak
7206.380	2.98	36.16	35.15	26.69	30.68	54.0	-23.32	AV
9608.000	---	---	---	---	---	---	---	---
12010.00	---	---	---	---	---	---	---	---
14412.00	---	---	---	---	---	---	---	---
16814.00	---	---	---	---	---	---	---	---
---	---	---	---	---	---	---	---	---

Vertical CH Low (2402MHz)								
Frequency MHz	Cable Loss dB	Ant Factor dB/m	Preamp Factor dB	Read Level dB μ V	Level dB μ V/m	Limit dB μ V/m	Over Limit dB	Remark
2402.000	2.17	31.21	35.30	87.66	85.74	114.0	-28.26	Peak
2402.000	2.17	31.21	35.30	80.04	78.12	94.0	-15.88	AV
4804.240	2.56	34.01	34.71	46.37	48.23	74.0	-25.77	Peak
4804.240	2.56	34.01	34.71	34.42	36.28	54.0	-17.72	AV
7206.380	2.98	36.16	35.15	38.90	42.89	74.0	-31.11	Peak
7206.380	2.98	36.16	35.15	33.47	37.46	54.0	-16.54	AV
9608.000	---	---	---	---	---	---	---	---
12010.00	---	---	---	---	---	---	---	---
14412.00	---	---	---	---	---	---	---	---
16814.00	---	---	---	---	---	---	---	---
---	---	---	---	---	---	---	---	---

Horizontal
CH Middle (2440MHz)

Frequency MHz	Cable Loss dB	Ant Factor dB/m	Preamp Factor dB	Read Level dB μ V	Level dB μ V/m	Limit dB μ V/m	Over Limit dB	Remark
2440.000	2.19	31.22	34.60	90.12	88.93	114.0	-25.07	Peak
2440.000	2.19	31.22	34.60	82.21	81.02	94.0	-12.98	AV
4880.160	2.57	35.00	34.58	43.74	46.73	74.0	-27.27	Peak
4880.160	2.57	35.00	34.58	36.85	39.84	54.0	-14.16	AV
7320.320	3.00	36.17	35.14	40.31	44.34	74.0	-29.66	Peak
7320.320	3.00	36.17	35.14	38.06	42.09	54.0	-11.91	AV
9760.000	---	---	---	---	---	---	---	---
12220.00	---	---	---	---	---	---	---	---
14640.00	---	---	---	---	---	---	---	---
17080.00	---	---	---	---	---	---	---	---
---	---	---	---	---	---	---	---	---

Vertical
CH Middle (2440MHz)

Frequency MHz	Cable Loss dB	Ant Factor dB/m	Preamp Factor dB	Read Level dB μ V	Level dB μ V/m	Limit dB μ V/m	Over Limit dB	Remark
2440.000	2.19	31.22	34.60	89.34	88.15	114.0	-25.85	Peak
2440.000	2.19	31.22	34.60	80.23	79.04	94.0	-14.96	AV
4880.160	2.57	35.00	34.58	46.59	49.58	74.0	-24.42	Peak
4880.160	2.57	35.00	34.58	42.18	45.17	54.0	-8.83	AV
7320.320	3.00	36.17	35.14	41.67	45.70	74.0	-28.30	Peak
7320.320	3.00	36.17	35.14	37.25	41.28	54.0	-12.72	AV
9760.000	---	---	---	---	---	---	---	---
12220.00	---	---	---	---	---	---	---	---
14640.00	---	---	---	---	---	---	---	---
17080.00	---	---	---	---	---	---	---	---
---	---	---	---	---	---	---	---	---

Horizontal
CH High (2479.5MHz)

Frequency MHz	Cable Loss dB	Ant Factor dB/m	Preamp Factor dB	Read Level dB μ V	Level dB μ V/m	Limit dB μ V/m	Over Limit dB	Remark
2479.500	2.20	31.65	36.00	93.56	91.41	114.0	-22.59	Peak
2479.500	2.20	31.65	36.00	82.42	80.27	94.0	-13.73	AV
4959.000	2.58	35.06	34.79	43.64	46.49	74.0	-27.51	Peak
4959.000	2.58	35.06	34.79	39.56	42.41	54.0	-11.59	AV
7438.500	3.02	36.19	34.90	48.41	52.72	74.0	-21.28	Peak
7438.500	3.02	36.20	35.20	39.55	43.57	54.0	-10.43	AV
9918.000	---	---	---	---	---	---	---	---
12397.50	---	---	---	---	---	---	---	---
14877.00	---	---	---	---	---	---	---	---
17356.50	---	---	---	---	---	---	---	---
---	---	---	---	---	---	---	---	---

Vertical
CH High (2479.5MHz)

Frequency MHz	Cable Loss dB	Ant Factor dB/m	Preamp Factor dB	Read Level dB μ V	Level dB μ V/m	Limit dB μ V/m	Over Limit dB	Remark
2479.500	2.20	31.65	36.00	95.15	93.00	114.0	-21.00	Peak
2479.500	2.20	31.65	36.00	82.13	79.98	94.0	-14.02	AV
4959.000	2.58	35.06	34.79	44.39	47.24	74.0	-26.76	Peak
4959.000	2.58	35.06	34.79	38.45	41.30	54.0	-12.70	AV
7438.500	3.02	36.19	34.90	42.67	46.98	74.0	-27.02	Peak
7438.500	3.02	36.20	35.20	40.33	44.35	54.0	-9.65	AV
9918.000	---	---	---	---	---	---	---	---
12397.50	---	---	---	---	---	---	---	---
14877.00	---	---	---	---	---	---	---	---
17356.50	---	---	---	---	---	---	---	---
---	---	---	---	---	---	---	---	---

NOTE: “ --- ” in the table above means the reading of emissions are attenuated more than 20dB below the permissible limits or the field strength is too small to be measured. The results of different modulations are the same.

6. Bandedge

6.1. Requirements (15.249):

The field strength of any emissions appearing outside the band edges and up to 10 kHz above and below the band edges shall be attenuated at least 50 dB below the level of the carrier or to the general limits of 15.249.

6.2. Test Procedure

The EUT is placed on a turn table which is 1.5 meter high above the ground. The turn table can rotate 360 degrees to determine the position of the maximum emission level. The EUT is set 3 meters away from the receiving antenna which is mounted on a antenna tower. The antenna can be moved up and down from 1 to 4 meters to find out the maximum emission level. Both horizontal and vertical polarization of the antenna are set on test. The device is evaluated in xyz orientation.

Test Equipment

Same as the equipment listed in 6.3.

6.3. Test Configuration:

30M to 1G emissions:

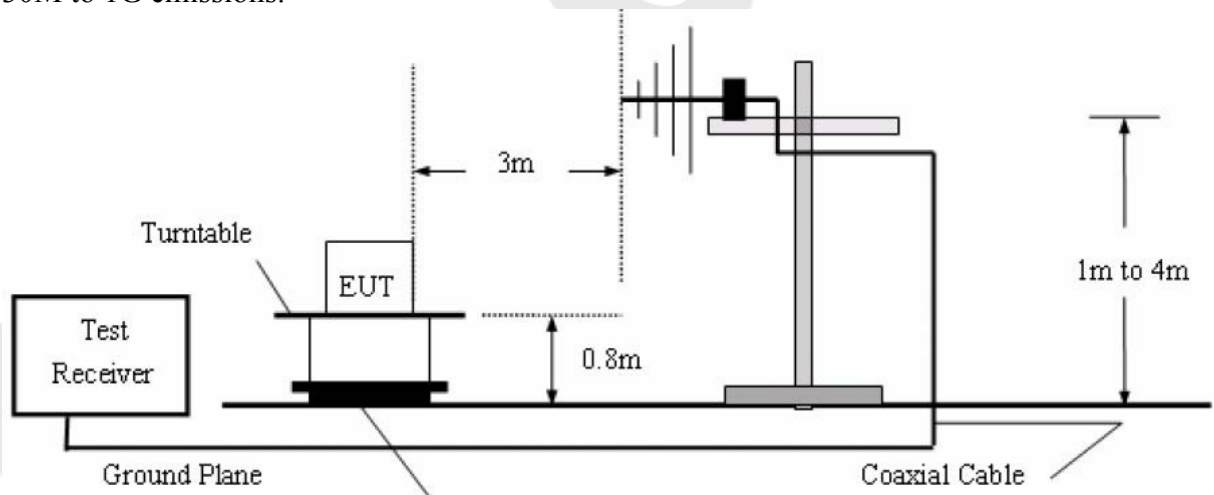

1G to 40G emissions:

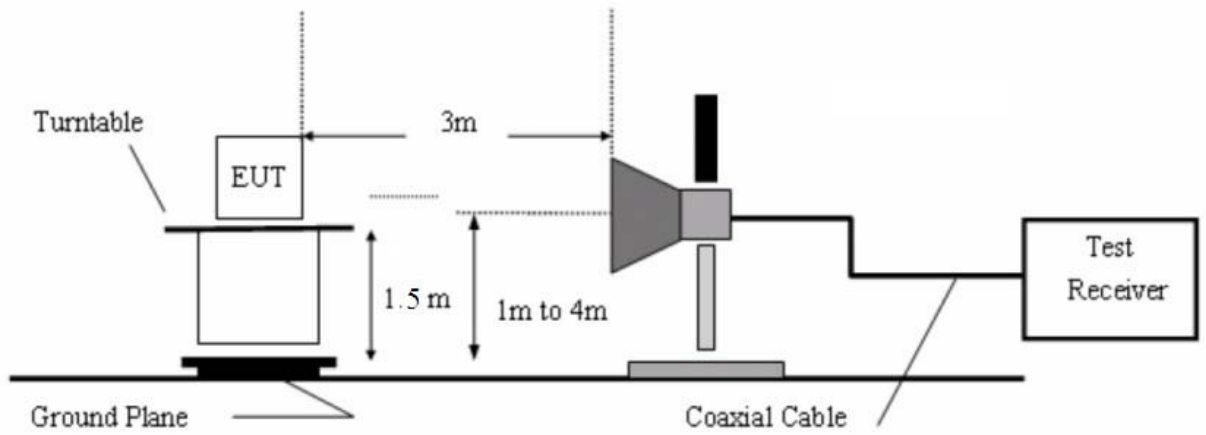

6.4. Test Results

Pass.

Please refer the following plot. Only the worst case (x orientation).

Anbotek

Job No.:	0217030011W	Polarization:	Horizontal
Standard:	(RE)FCC PART15 C _3m	Power Source:	DC 3.7V Battery
Test item:	Radiation Test	Temp.(C)/Hum.(%RH):	24.3(C)/55%RH
Note:	PEAK	Distance:	3m

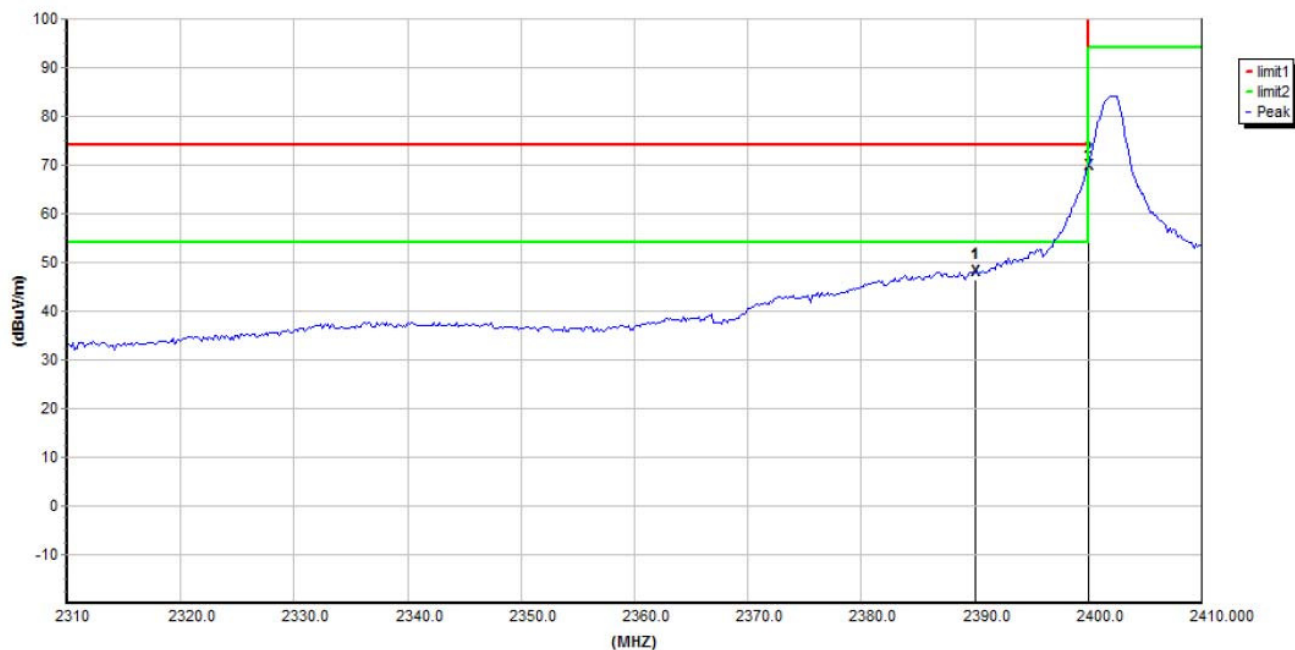

No.	Freq. (MHz)	Reading (dBuV)	Antenna Factor	Cable Loss (dB)	Amp. (dB)	Level (dBuV/m)	Limit (dBuV/m)	Over Limit (dB)	Detector
1	2390.0000	50.14	30.75	2.13	35.22	47.80	74.00	-26.20	Peak
2	2400.0000	72.01	30.80	2.15	35.26	69.70	74.00	-4.30	Peak

AMR

Job No.:	0217030011W	Polarization:	Vertical
Standard:	(RE)FCC PART15 C _3m	Power Source:	DC 3.7V Battery
Test item:	Radiation Test	Temp.(C)/Hum.(%RH):	24.3(C)/55%RH
Note:	PEAK	Distance:	3m

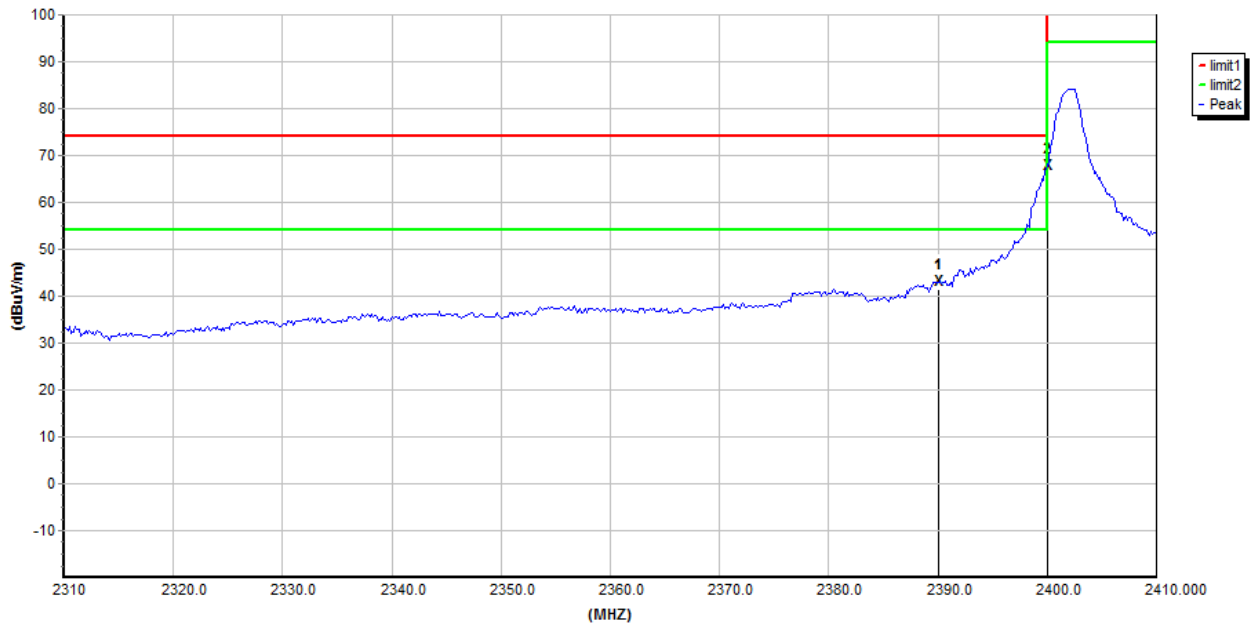

No.	Freq. (MHz)	Reading (dBuV)	Antenna Factor	Cable Loss (dB)	Amp. (dB)	Level (dBuV/m)	Limit (dBuV/m)	Over Limit (dB)	Detector
1	2390.0000	45.14	30.75	2.13	35.22	42.80	74.00	-31.20	Peak
2	2400.0000	70.01	30.80	2.15	35.26	67.70	74.00	-6.30	Peak

AMR

Job No.:	0217030011W	Polarization:	Horizontal
Standard:	(RE)FCC PART15 C _3m	Power Source:	DC 3.7V Battery
Test item:	Radiation Test	Temp.(C)/Hum.(%RH):	24.3(C)/55% RH
Note:	AV	Distance:	3m

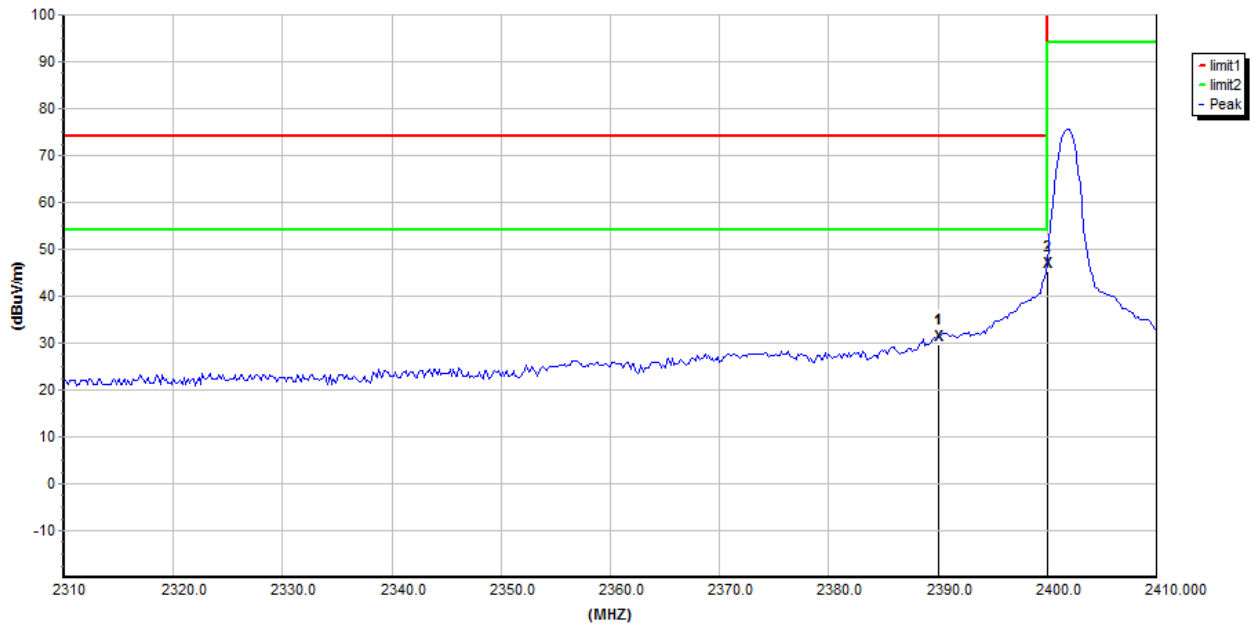

No.	Freq. (MHz)	Reading (dBuV)	Antenna Factor	Cable Loss (dB)	Amp. (dB)	Level (dBuV/m)	Limit (dBuV/m)	Over Limit (dB)	Detector
1	2390.0000	33.48	30.75	2.13	35.22	31.14	54.00	-22.86	AVG
2	2400.0000	49.13	30.80	2.15	35.26	46.82	54.00	-7.18	AVG

AMR

Job No.:	0217030011W	Polarization:	Vertical
Standard:	(RE)FCC PART15 C_3m	Power Source:	DC 3.7V Battery
Test item:	Radiation Test	Temp.(C)/Hum.(%RH):	24.3(C)/55%RH
Note:	AV	Distance:	3m

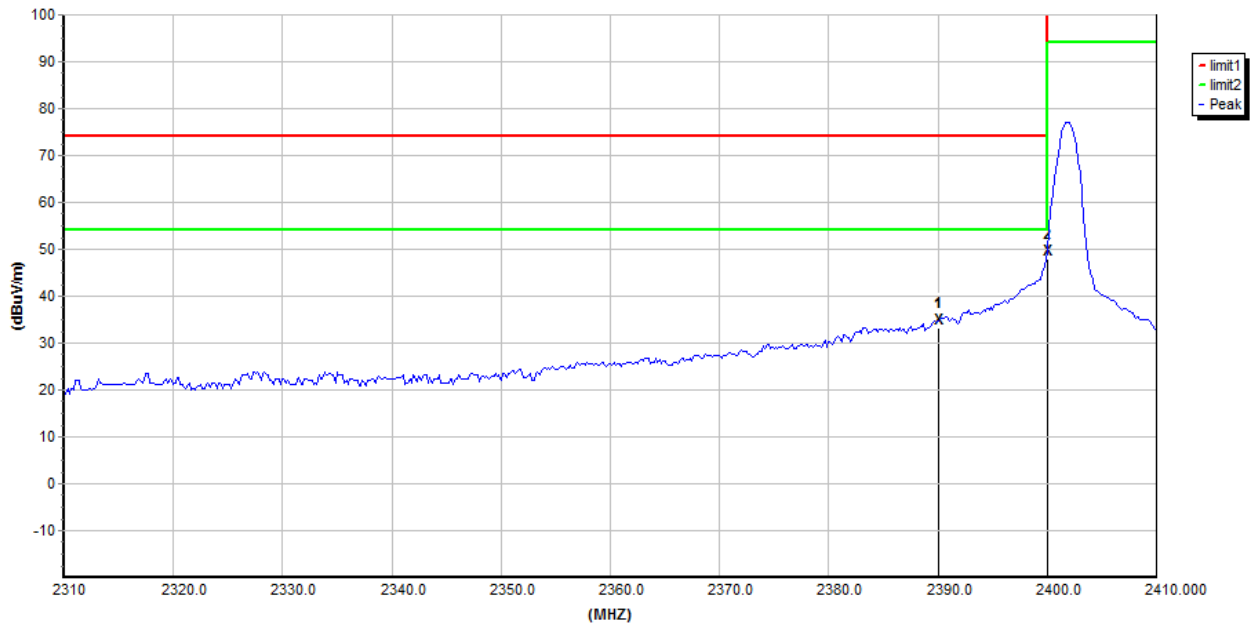

No.	Freq. (MHz)	Reading (dBuV)	Antenna Factor	Cable Loss (dB)	Amp. (dB)	Level (dBuV/m)	Limit (dBuV/m)	Over Limit (dB)	Detector
1	2390.0000	36.98	30.75	2.13	35.22	34.64	54.00	-19.36	AVG
2	2400.0000	51.63	30.80	2.15	35.26	49.32	54.00	-4.68	AVG

AVG

Job No.:	0217030011W	Polarization:	Horizontal
Standard:	(RE)FCC PART15 C_3m	Power Source:	DC 3.7V Battery
Test item:	Radiation Test	Temp.(C)/Hum.(%RH):	24.3(C)/55% RH
Note:	PEAK	Distance:	3m

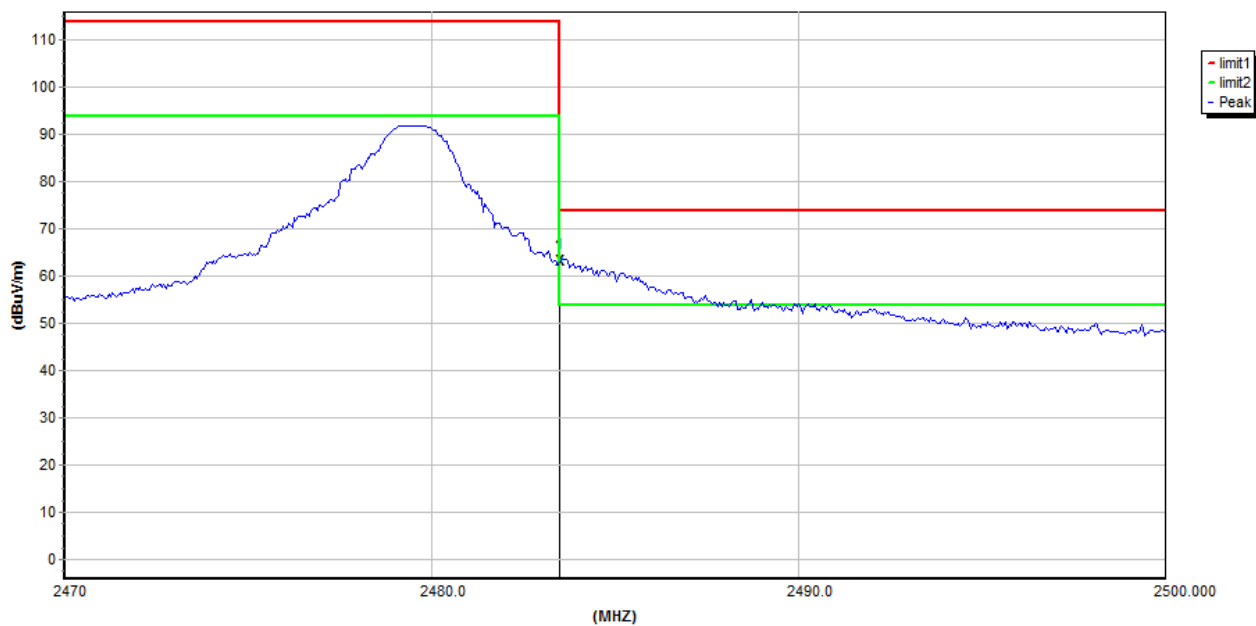

No.	Freq. (MHz)	Reading (dBuV)	Antenna Factor	Cable Loss (dB)	Amp. (dB)	Level (dBuV/m)	Limit (dBuV/m)	Over Limit	Detector
1	2483.5000	65.10	31.72	2.23	36.02	63.03	74.00	-10.97	Peak

AMC

Job No.:	0217030011W	Polarization:	Vertical
Standard:	(RE)FCC PART15 C _3m	Power Source:	DC 3.7V Battery
Test item:	Radiation Test	Temp.(C)/Hum.(%RH):	24.3(C)/55%RH
Note:	PEAK	Distance:	3m

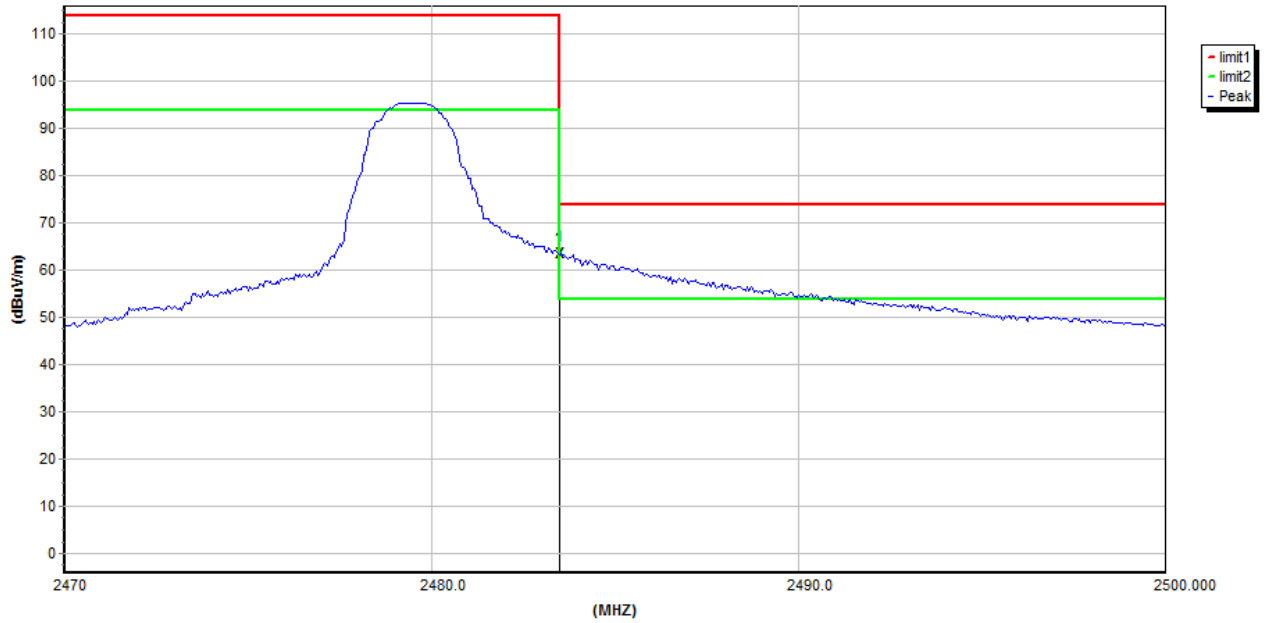

No.	Freq. (MHz)	Reading (dBuV)	Antenna Factor	Cable Loss (dB)	Amp. (dB)	Level (dBuV/m)	Limit (dBuV/m)	Over Limit	Detector
1	2483.5000	65.55	31.72	2.23	36.02	63.48	74.00	-10.52	Peak

AMR

Job No.:	0217030011W	Polarization:	Horizontal
Standard:	(RE)FCC PART15 C _3m	Power Source:	DC 3.7V Battery
Test item:	Radiation Test	Temp.(C)/Hum.(%RH):	24.3(C)/55% RH
Note:	AV	Distance:	3m

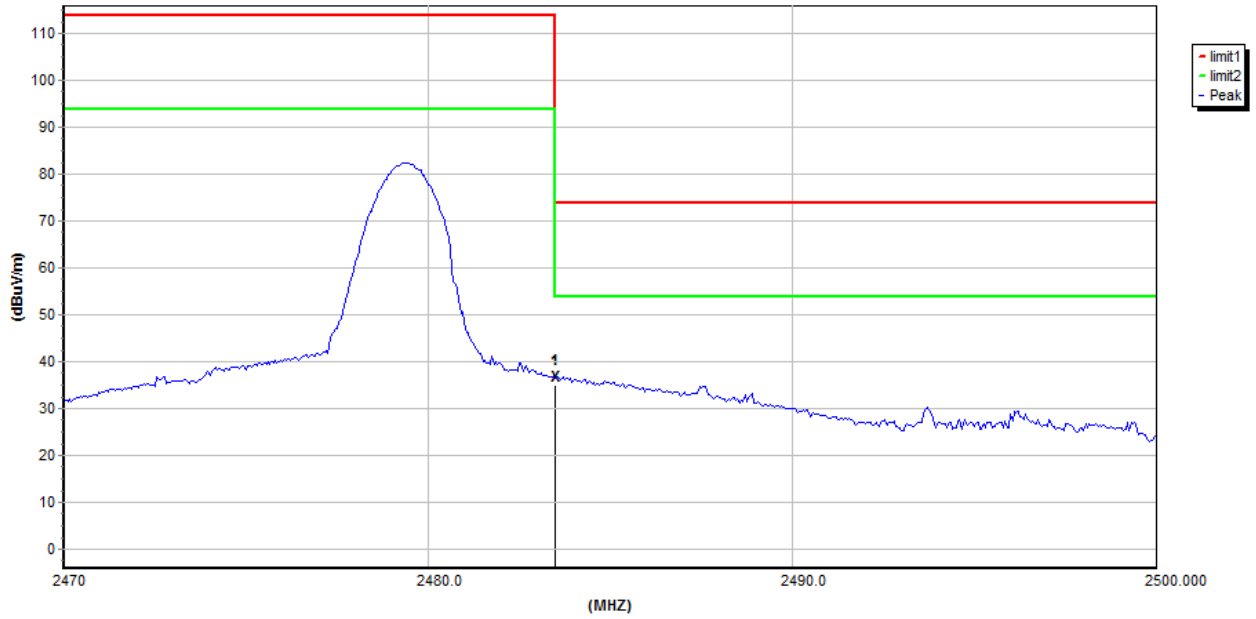

No.	Freq. (MHz)	Reading (dBuV)	Antenna Factor	Cable Loss (dB)	Amp. (dB)	Level (dBuV/m)	Limit (dBuV/m)	Over Limit	Detector
1	2483.5000	38.61	31.72	2.23	36.02	36.54	54.00	-17.46	AVG

AVG

Job No.:	0217030011W	Polarization:	Vertical
Standard:	(RE)FCC PART15 C_3m	Power Source:	DC 3.7V Battery
Test item:	Radiation Test	Temp.(C)/Hum.(%RH):	24.3(C)/55%RH
Note:	AV	Distance:	3m

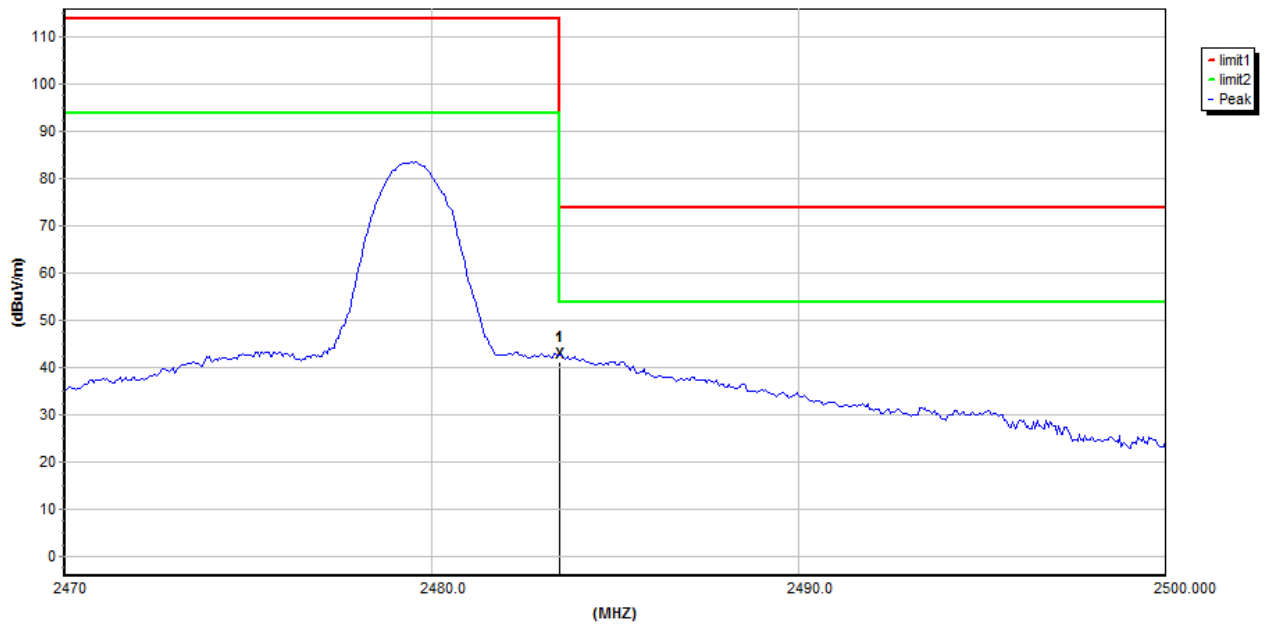

No.	Freq. (MHz)	Reading (dBuV)	Antenna Factor	Cable Loss (dB)	Amp. (dB)	Level (dBuV/m)	Limit (dBuV/m)	Over Limit	Detector
1	2483.5000	44.92	31.72	2.23	36.02	42.85	54.00	-11.15	AVG

AVG

7. Occupied Bandwidth

7.1. Requirements :

According to 15.215 (c), intentional radiators operating under the alternative provisions to the general emission limits, as contained in §§15.217 through 15.257 and in Subpart E of this part, must be designed to ensure that the 20 dB bandwidth of the emission, or whatever bandwidth may otherwise be specified in the specific rule section under which the equipment operates, is contained within the frequency band designated in the rule section under which the equipment is operated. The requirement to contain the designated bandwidth of the emission within the specified frequency band includes the effects from frequency sweeping, frequency hopping and other modulation techniques that may be employed as well as the frequency stability of the transmitter over expected variations in temperature and supply voltage. If a frequency stability is not specified in the regulations, it is recommended that the fundamental emission be kept within at least the central 80% of the permitted band in order to minimize the possibility of out-of-band operation.

7.2. Test SET-UP

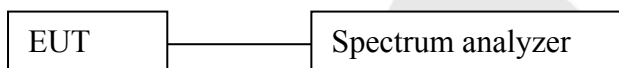

7.3 Test Equipment

Same as the equipment listed in 5.3.

7.4. Test Results

Pass.

Please refer the following plot.

20dB Down:

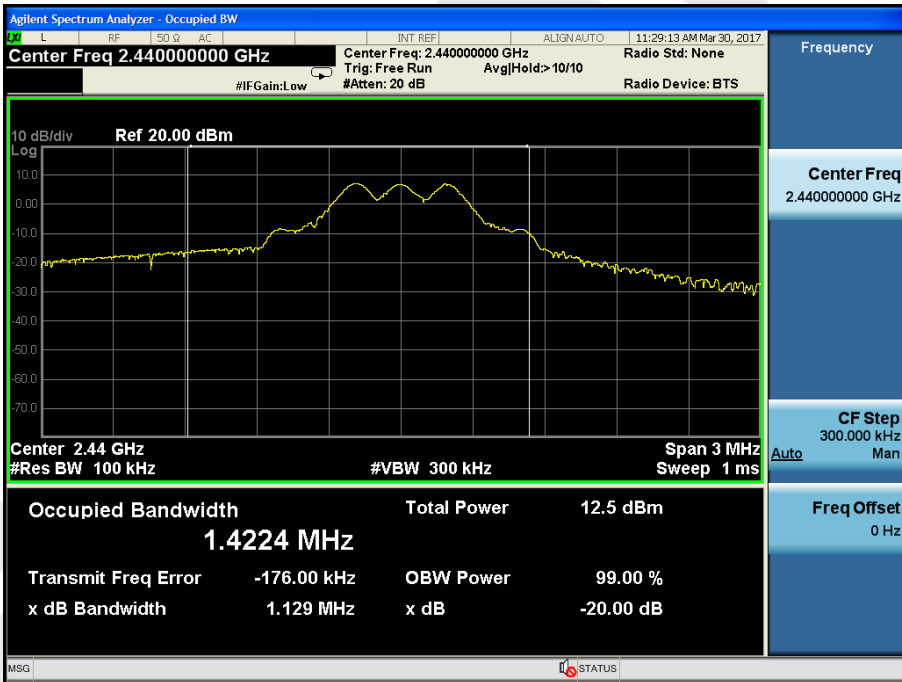
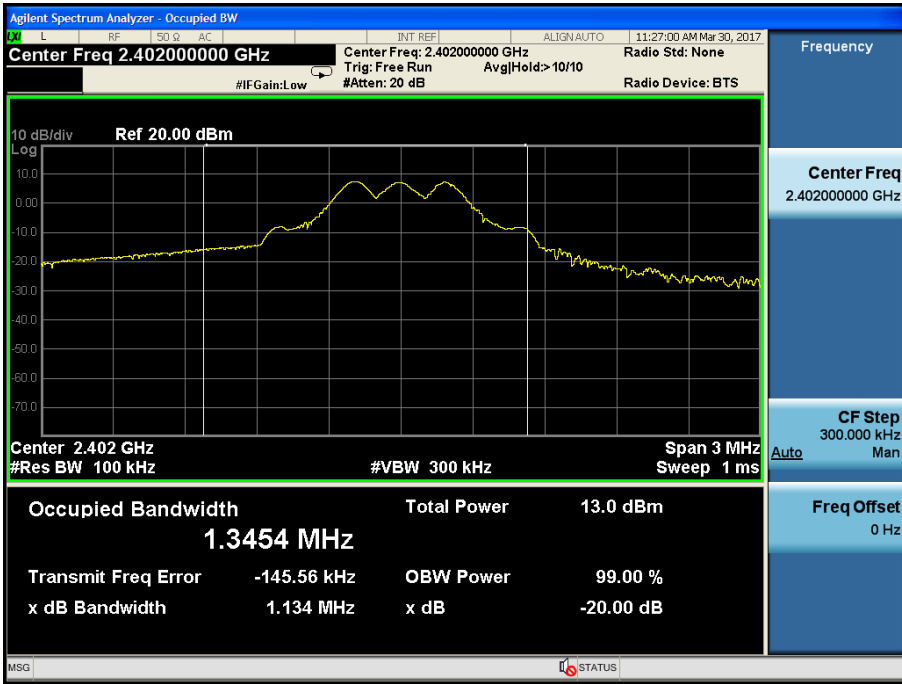

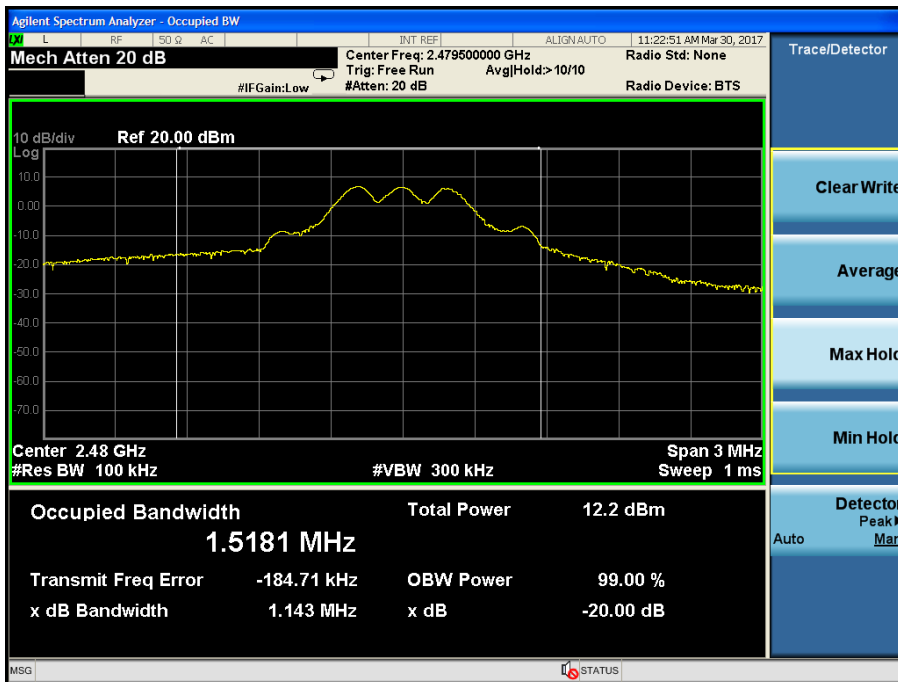

Anbotek

8. ANTENNA APPLICATION

8.1. Antenna requirement

The EUT'S antenna is met the requirement of FCC part 15C section 15.203.

An intentional radiator shall be designed to ensure that no antenna other than that furnished by the responsible party shall be used with the device. The use of a permanently attached antenna or of an antenna that uses a unique coupling to the intentional radiator shall be considered sufficient to comply with the provisions of this section. The manufacturer may design the unit so that a broken antenna can be replaced by the user, but the use of a standard antenna jack or electrical connector is prohibited. This requirement does not apply to carrier current devices or to devices operated under the provisions of §15.211, §15.213, §15.217, §15.219, or §15.221. Further, this requirement does not apply to intentional radiators that must be professionally installed, such as perimeter protection systems and some field disturbance sensors, or to other intentional radiators which, in accordance with §15.31(d), must be measured at the installation site. However, the installer shall be responsible for ensuring that the proper antenna is employed so that the limits in this part are not exceeded.

8.2. Result

The EUT's antenna used a PCB antenna which is permanently attached, The antenna's gain is 2dBi and meets the requirement.

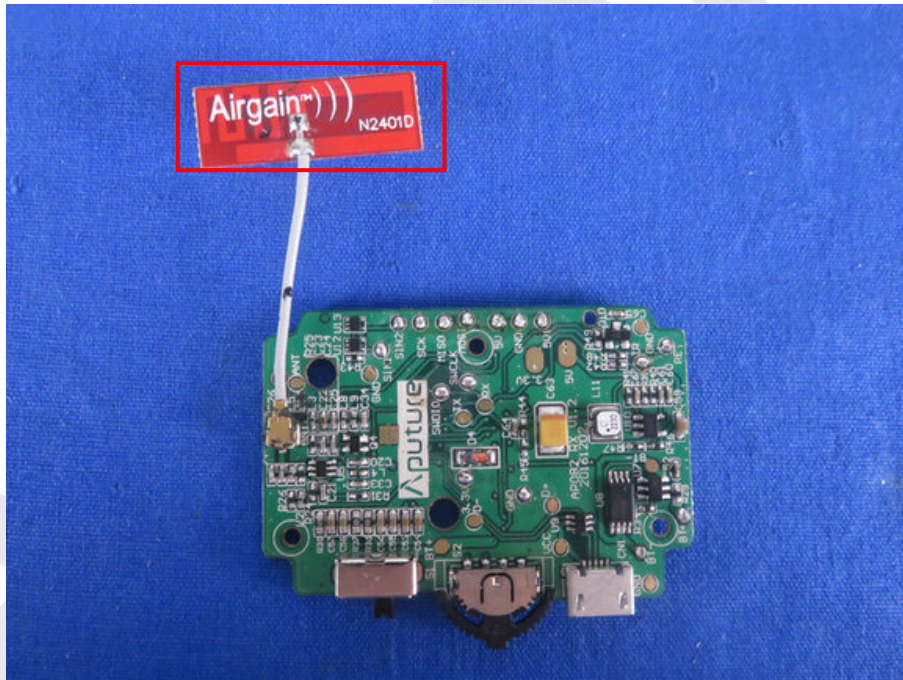

9. PHOTOGRAPH

9.1 Photo of Power Line Conducted Emission Measurement



9.2 Photo of Radiation Emission Test

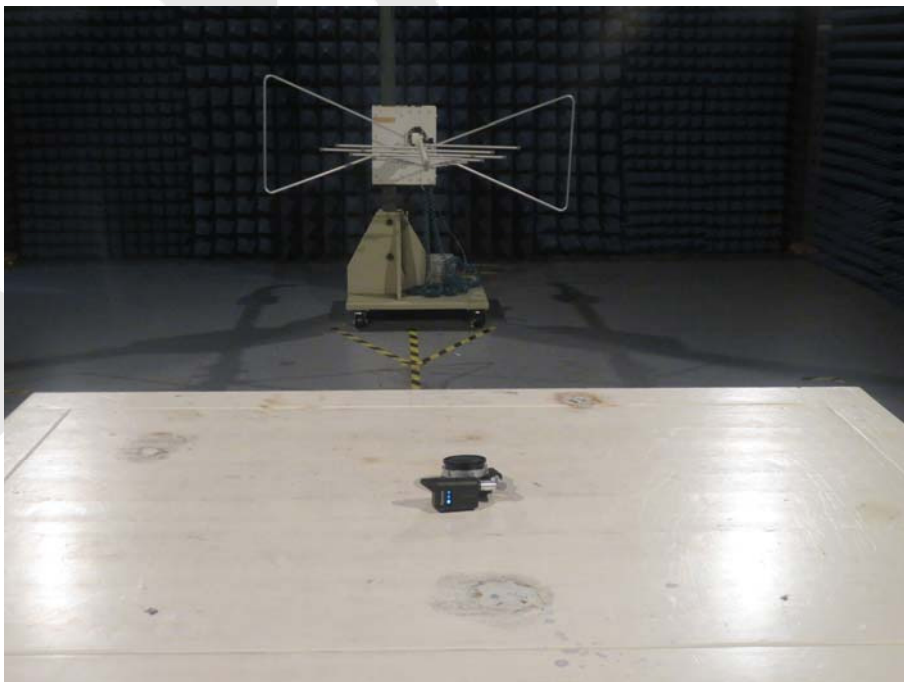

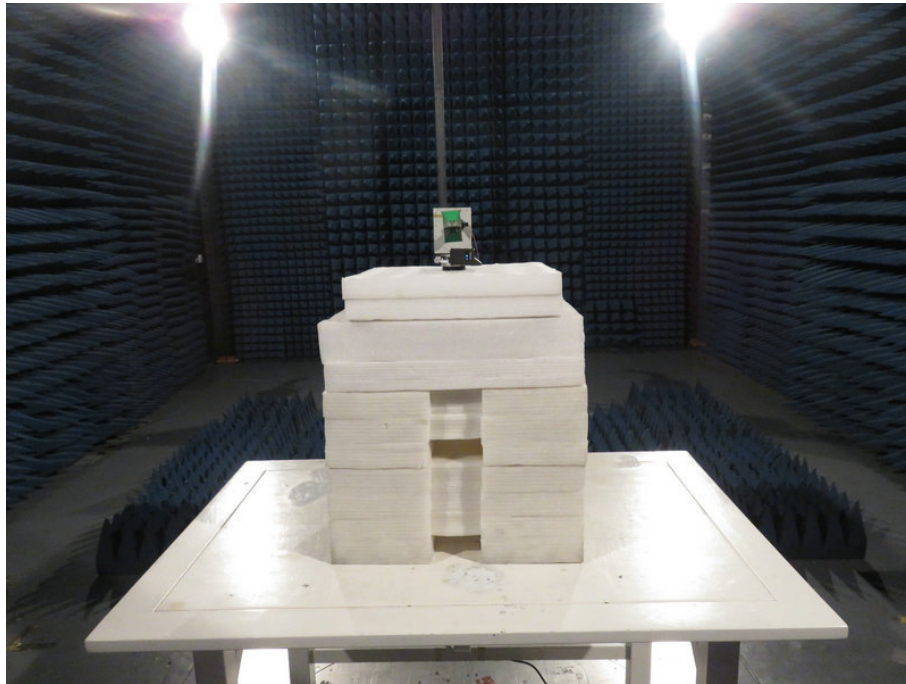

Anbotek

APPENDIX I (EXTERNAL PHOTOS)

1. Figure



2. Figure



3. Figure



4. Figure

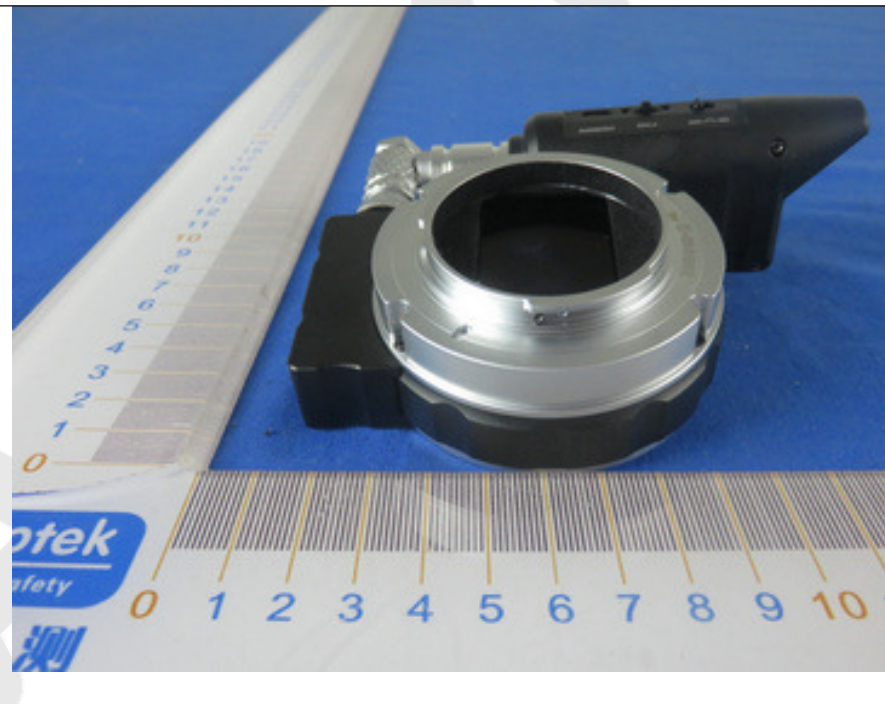

5. Figure



6. Figure

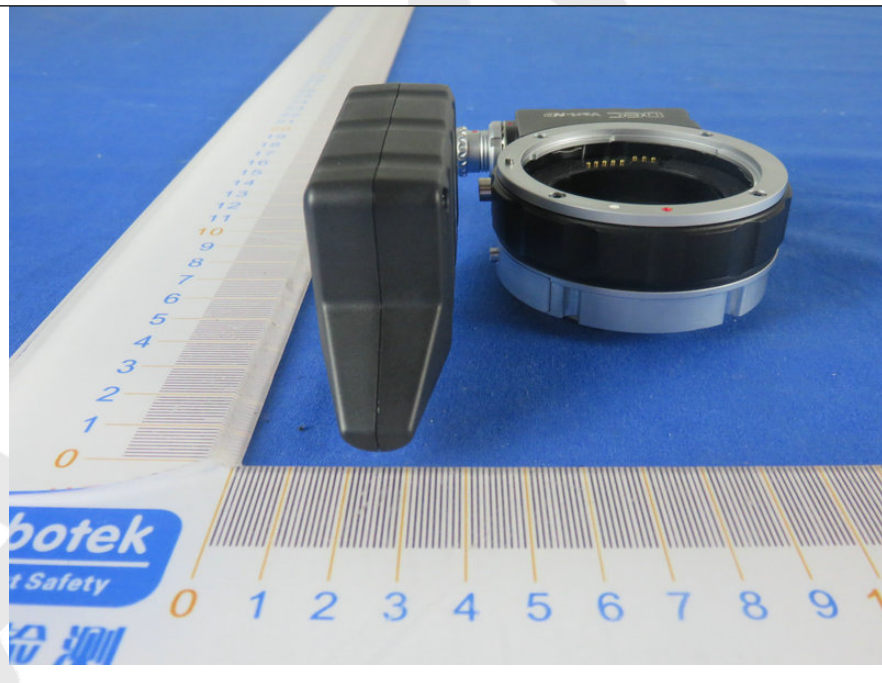

APPENDIX II (INTERNAL PHOTOS)

1. Figure



2. Figure

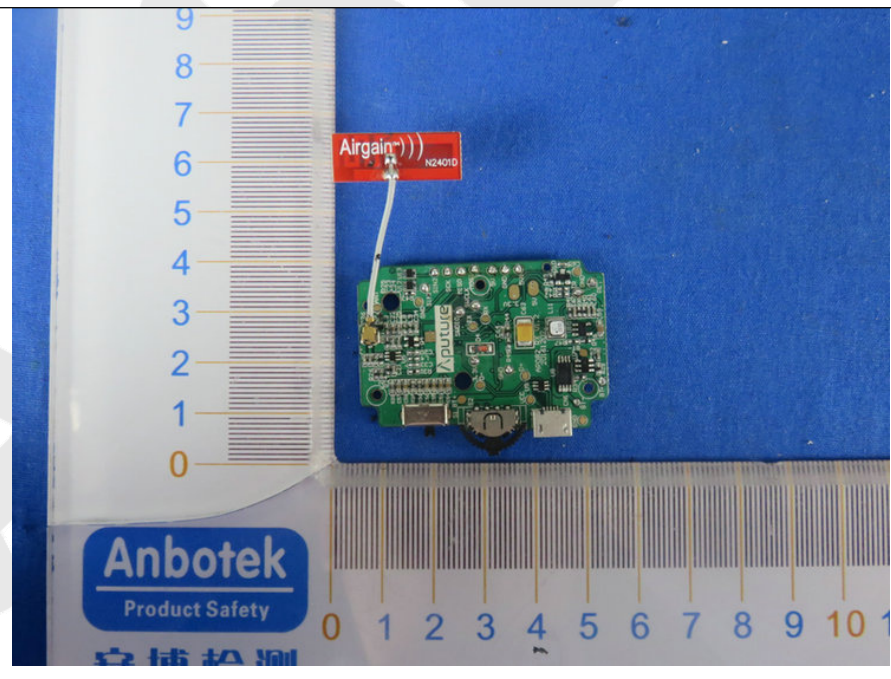

3. Figure

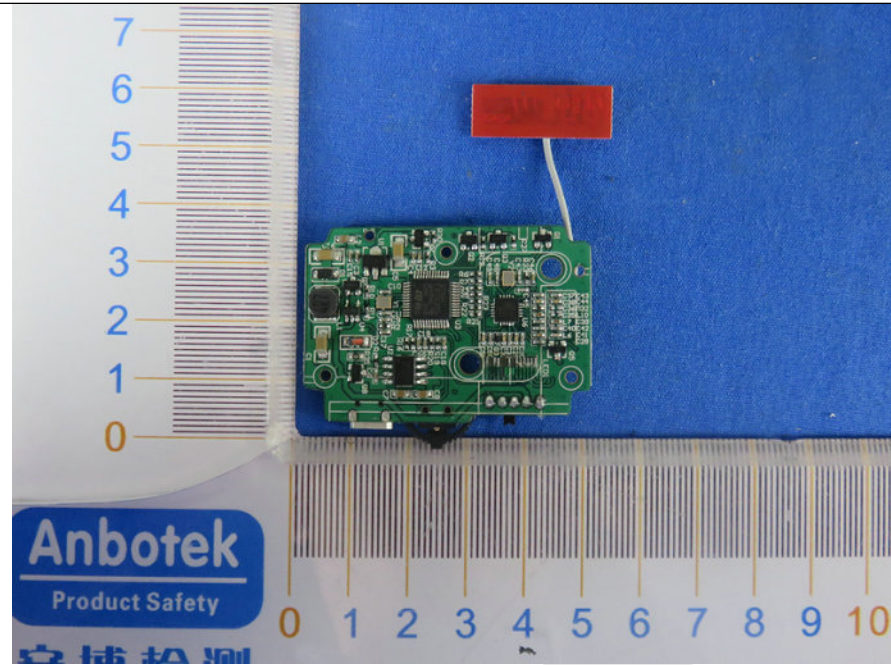

4. Figure

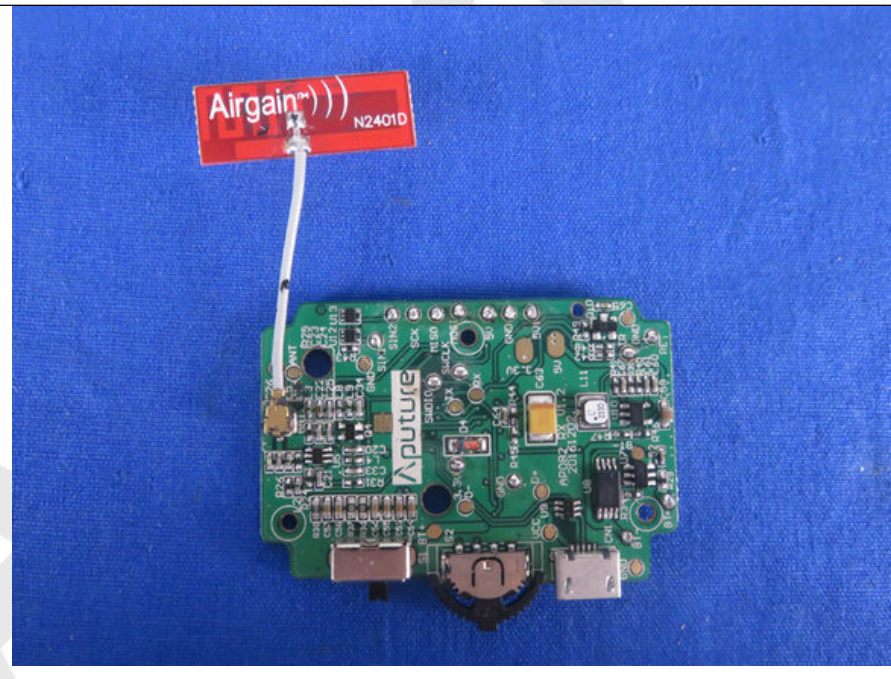

5. Figure

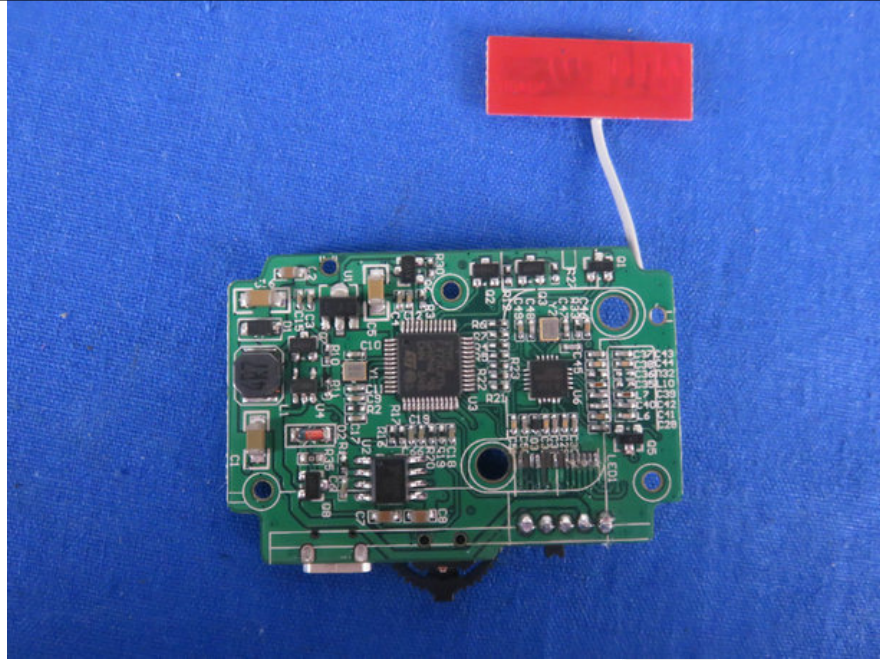

6. Figure



7. Figure



8. Figure

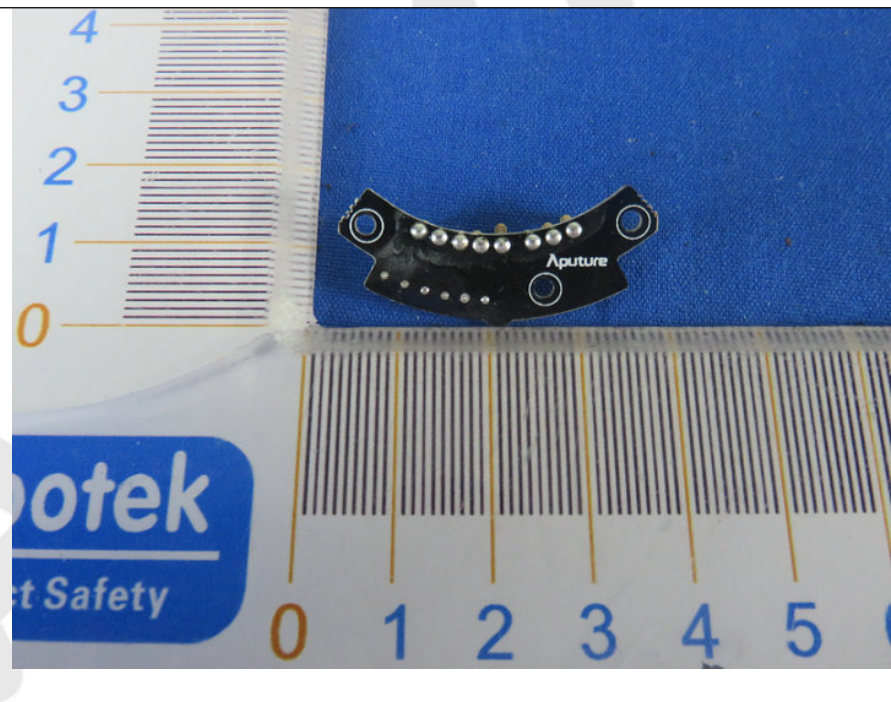

9. Figure



10. Figure

