USER MANUAL

CONTENT

CONTENT.....	1
1.Device Overview.....	2
1.1 Features.....	2
1.2 Applications.....	2
1.3 Functional Block Diagram.....	3
2. Pin Configuration and Functions.....	3
2.1 Module Pin Diagram.....	3
2.2 Pin Functions.....	4
3. Specifications.....	7
3.1 Absolute Maximum Rating.....	7
3.2 Recommended Operating Conditions.....	7
3.3 RF Characteristics.....	7
3.4 Power Consumption Summary.....	8
4. Application, Implementation, and Layout.....	9
4.1 Application Diagram.....	9
4.2 Typical Application Circuit.....	9
4.3 Layout Guideline.....	9
5. Mechanical and Package.....	10
5.1 Module Figure.....	10
5.2 Mechanical Dimension.....	10
5.3 Packaging Information.....	11
6. Thermal Reflow.....	12
7. Revision History.....	13

1. Device Overview

The Module is designed base on the Cypress® CYW20735 and the CYW0735 is a Bluetooth 5.0-compliant, stand-alone baseband processor with an integrated 2.4 GHz transceiver. This project only supports BLE 1MHz, BLE 2MHz is blocked by software.

The Module is the optimal solution for applications in wireless input devices including game controllers, remote controls, keyboards, and joysticks. Built-in firmware adheres to the Bluetooth Low Energy (BLE) profile and the BLE Human Interface Device (HID) profile.

1.1 Features

- 1) Bluetooth 5.0 .
- 2) Supports Bluetooth Low Energy(BLE)
- 3) BLE HID profile version 1.00 compliant
- 4) Bluetooth Device ID profile version 1.3 compliant
- 5) Supports Generic Access Profile (GAP)
- 6) Auxiliary ADC with up to 15 analog channels
- 7) Programmable key scan matrix interface, up to 8×8 key-scanning matrix

1.2 Applications

- 1) Game controllers&Joysticks
- 2) Wireless pointing devices (mice)&Wireless keyboards
- 3) Home automation
- 4) Remote controls
- 5) Find-me devices
- 6) SIG Mesh

1.3 Functional Block Diagram

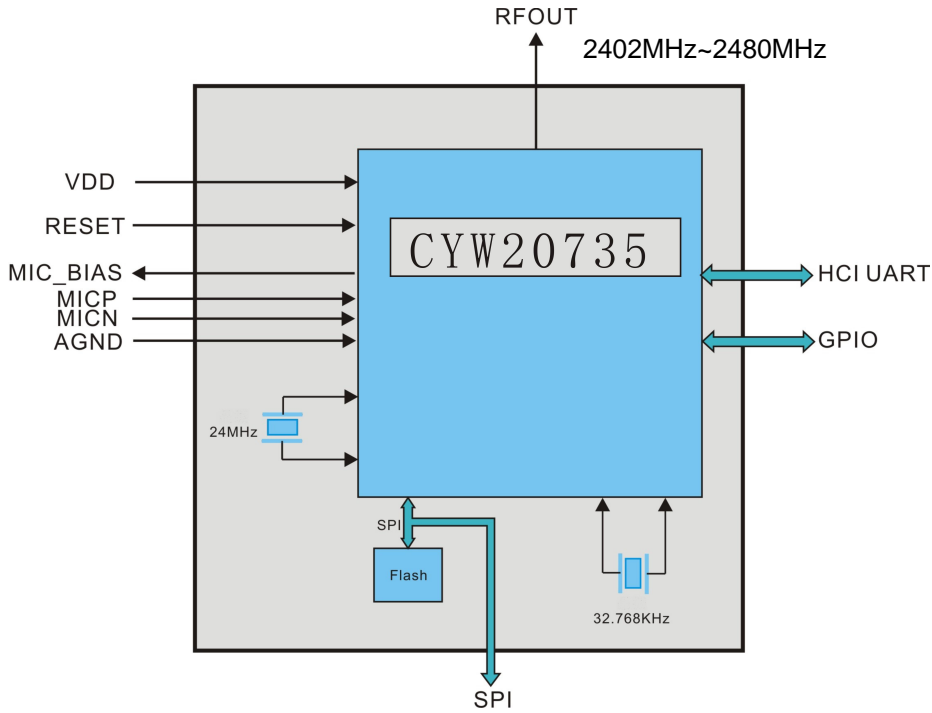

2. Pin Configuration and Functions

2.1 Module Pin Diagram

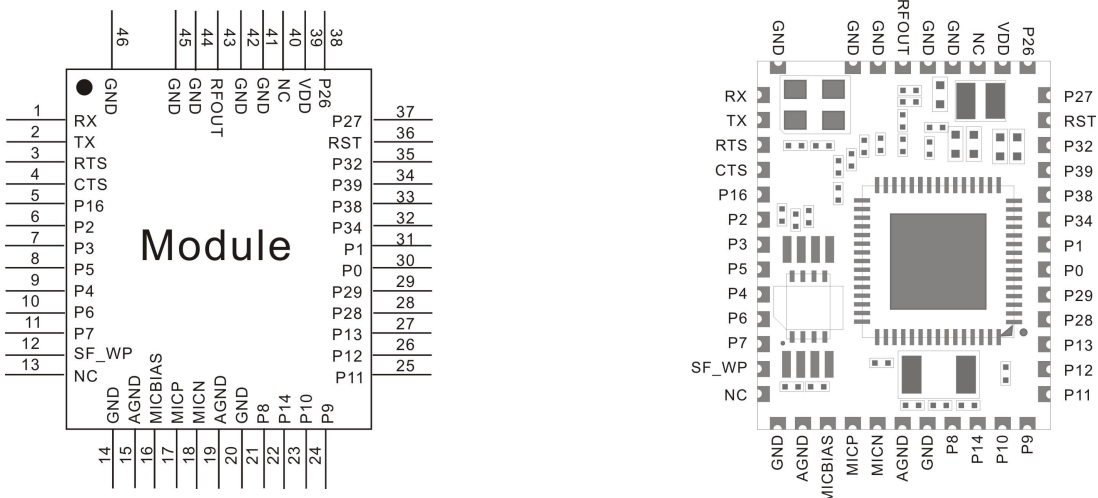

module pin assignments

2.2 Pin Functions

Pin	Name	IO Type	Description
1	RX	I	UART serial input. Serial data input for the HCI UART interface
2	TX	O, PU	UART serial input. Serial data input for the HCI UART interface
3	RTS	O, PU	RTS for HCI UART interface
4	CTS	I, PU	CTS for HCI UART interface:
5	P16	Input	<ul style="list-style-type: none"> • GPIO: P16 • Keyboard scan output (column): KSO8 • A/D converter input 19
6	P2	Input	<ul style="list-style-type: none"> • GPIO: P2 • Keyboard scan input (row): KSI2 • Peripheral UART: puart_rx • SPI_1: SPI_CS (slave only) • SPI_1: MOSI (master only)
7	P3	Input	<ul style="list-style-type: none"> • GPIO: P3 • Keyboard scan input (row): KSI3 • Peripheral UART: puart_cts • SPI_1: SPI_CLK (master and slave)
8	P5	Input	<ul style="list-style-type: none"> • GPIO: P5 • Keyboard scan input (row): KSI5 • Peripheral UART: puart_tx • SPI_1: MISO (master and slave) • BSC: SDA
9	P4	Input	<ul style="list-style-type: none"> • GPIO: P4 • Keyboard scan input (row): KSI4 • Peripheral UART: puart_rx • SPI_1: MOSI (master and slave) • IR_TX
10	P6	Input	<ul style="list-style-type: none"> • GPIO: P6 • Keyboard scan input (row): KSI6 • Peripheral UART: puart_rts • SPI_1: SPI_CS (slave only)
11	P7	Input	<ul style="list-style-type: none"> • GPIO: P7 • Keyboard scan input (row): KSI7 • Peripheral UART: puart_cts • SPI_1: SPI_CLK (master and slave) • BSC: SCL
12	SF_WP	Input	Flash WP port
13	NC	NC	NC
14	GND	Ground	Ground
15	AGND	Analog ground	Analog ground
16	MICBIAS	Input	Microphone bias supply
17	MICP	Input	Microphone positive input
18	MICN	Input	Microphone negative input
19	AGND	Analog ground	Analog ground

20	GND	Input	Analog ground
21	P8	Input	<ul style="list-style-type: none"> • GPIO: P8 • Keyboard scan output (column): KSO0 • A/D converter input 27
22	P14	Input	<ul style="list-style-type: none"> • GPIO: P14 • Keyboard scan output (column): KSO6 • A/D converter input 21 • PWM2
23	P10	Input	<ul style="list-style-type: none"> • GPIO: P10 • Keyboard scan output (column): KSO2 • A/D converter input 25
24	P9	Input	<ul style="list-style-type: none"> • GPIO: P9 • Keyboard scan output (column): KSO1 • A/D converter input 26
25	P11	Input	<ul style="list-style-type: none"> • GPIO: P11 • Keyboard scan output (column): KSO3 • A/D converter input 24
26	P12	Input	<ul style="list-style-type: none"> • GPIO: P12 • Keyboard scan output (column): KSO4 • A/D converter input 23
27	P13	Input	<ul style="list-style-type: none"> • GPIO: P13 • Keyboard scan output (column): KSO5 • A/D converter input 22 • PWM3
28	P28	Input	<ul style="list-style-type: none"> • GPIO: P28 • Optical control output: QOC2 • A/D converter input 11 • LED1 <p>Current: 16 mA sink</p>
29	P29	Input	<ul style="list-style-type: none"> • GPIO: P29 • Optical control output: QOC3 • A/D converter input 10 • LED2 <p>Current: 16 mA sink</p>
30	P0	Input	<ul style="list-style-type: none"> • GPIO: P0 • Keyboard scan input (row): KSI0 • A/D converter input 29 • Peripheral UART: uart_tx • SPI_1: MOSI (master and slave) • IR_RX
31	P1	Input	<ul style="list-style-type: none"> • GPIO: P1 • Keyboard scan input (row): KSI1 • A/D converter input 28 • Peripheral UART: uart_rts • SPI_1: MISO (master and slave) • IR_TX
32	P34	Input	<ul style="list-style-type: none"> • GPIO: P34 • A/D converter input 5 • Quadrature: QDY0 • Peripheral UART: uart_rx
33	P38	Input	<ul style="list-style-type: none"> • GPIO: P38 • A/D converter input 1 • SPI_1: MOSI (master and slave) • IR_TX
34	P39	Input	<ul style="list-style-type: none"> • GPIO: P39 • SPI_1: SPI_CS (slave only)

35	P32	Analog ground	Analog ground
36	RST	I/O,PU	Active-low system reset with open-drain output and internal pull-up resistor.
37	P27	Input	<ul style="list-style-type: none"> • GPIO: P27 • Keyboard scan output (column): KSO19 • SPI_1: MOSI (master and slave) • Optical control output: QOC1 • Triac control 2 Current: 16 mA sink
38	P26	Input	<ul style="list-style-type: none"> • GPIO: P26 • Keyboard scan output (column): KSO18 • SPI_1: SPI_CS (slave only) • Optical control output: QOC0 • Triac control 1 Current: 16 mA sink
39	VDD	Input	Supply Voltage input ,1.8V~3.6V
40	NC	NC	NC
41	GND	Ground	Ground
42	GND	Ground	Ground
43	RFOUT	Output	RF antenna port
44	GND	Ground	Ground
45	GND	Ground	Ground
46	GND	Ground	Ground

3. Specifications

3.1 Absolute Maximum Rating

- 1) Power supply voltage VDD:1.8V~3.6V(typical 3.3V)
- 2) MIC_BIAS output voltage: 2.1V typ.
- 3) Audio signal bandwidth:20Hz~8KHz

3.2 Recommended Operating Conditions

- 1) Operation temperature range: -30°C~+85°C
- 2) Storage temperature range: -40°C~+105°C

3.3 RF Characteristics

1) Receiver RF Specifications

Parameter	Conditions	Minimum	Typical ^a	Maximum	Unit
General					
Frequency range	–	2402	–	2480	MHz
RX sensitivity ^b	–	–	-91.5	–	–
Maximum input	GFSK, 1 Mbps	–	–	-20	dBm
Interference Performance					
TBD					
Out-of-Band Blocking Performance (CW)^c					
30 MHz–2000 MHz	0.1% BER	–	-10.0	–	dBm
2000–2399 MHz	0.1% BER	–	-27	–	dBm
2498–3000 MHz	0.1% BER	–	-27	–	dBm
3000 MHz–12.75 GHz	0.1% BER	–	-10.0	–	dBm
Intermodulation Performance^d					
BT, Df = 4 MHz	–	-39.0	–	–	dBm
Spurious Emissions^e					
30 MHz to 1 GHz	–	–	–	-62	dBm
1 GHz to 12.75 GHz	–	–	–	-47	dBm
65 MHz to 108 MHz	FM RX	–	-147	–	dBm/Hz
746 MHz to 764 MHz	CDMA	–	-147	–	dBm/Hz
851–894 MHz	CDMA	–	-147	–	dBm/Hz
925–960 MHz	EDGE/GSM	–	-147	–	dBm/Hz
1805–1880 MHz	EDGE/GSM	–	-147	–	dBm/Hz
1930–1990 MHz	PCS	–	-147	–	dBm/Hz
2110–2170 MHz	WCDMA	–	-147	–	dBm/Hz

2) Transmitter RF Specifications

Parameter	Conditions	Minimum	Typical	Maximum	Unit
General					
Frequency range	–	2402	–	2480	MHz
Out-of-Band Spurious Emissions					
30 MHz to 1 GHz	–	–	–	–36.0 ^a	dBm
1 GHz to 12.75 GHz	–	–	–	–30.0 ^{a, b}	dBm
1.8 GHz to 1.9 GHz	–	–	–	–47.0	dBm
5.15 GHz to 5.3 GHz	–	–	–	–47.0	dBm

3) BLE RF Specifications

Parameter	Conditions	Minimum	Typical	Maximum	Unit
Frequency range	N/A	2402	–	2480	MHz
RX sense ^a	GFSK, 0.1% BER, 1 Mbps	–	–94.5	–	dBm
Mod Char: Delta F1 average	N/A	225	255	275	kHz
Mod Char: Delta F2 max ^c	N/A	99.9	–	–	%
Mod Char: Ratio	N/A	0.8	0.95	–	%

4) Antenna

PCB antenna is widely used in short distance remote control and communication. This part outlines Printed Circuit Board (PCB) antennas used by this module.

Specifications and Interface

Standard	BT 5.0
Frequency range	2.4 to 2.49 GHz
Peak gain	3dBi @2.44 GHz
VSWR	< 2:1
Feed impedance	50 ohms
Power handling	30 dBm
Interface	50 ohms, 1.13 mm diameter, micro coax cable (available with optional U.FL-compatible cable connector and/or cable-mounted EMI ferrites)
Antenna dimensions	41.7 x 7.25x 1.6 (mm)
Weight	0.963g(0.034oz)
Temperature range	Operating: -40° C to +75° C (-40° F to +167° F) Storage: -40° C to +85° C (-40° F to +185° F)
Humidity range	0% to 95% non-condensing

3.4 Power Consumption Summary

BLE Current Consumption

<i>Operational Mode</i>	<i>Conditions</i>	<i>Typical</i>	<i>Max.</i>	<i>Unit</i>
Receiving	Receiver and baseband are both operating, 100% ON.	8	–	mA
Transmitting	Transmitter and baseband are both operating, 100% ON.	18	–	mA
Sleeping	32 kHz XTAL in use.	800	–	μA
Advertising	1.28s direct advertising in low power mode	30	–	μA
Connecting	1-second connection interval in Low Power mode	25	–	μA
HIDOFF (Deep Sleep)	–	1	–	μA

4. Application, Implementation, and Layout

4.1 Application Diagram

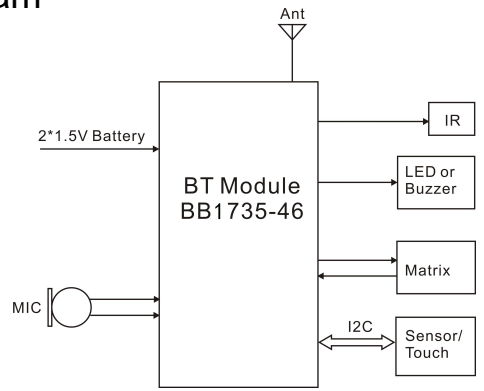

Remote control block diagram

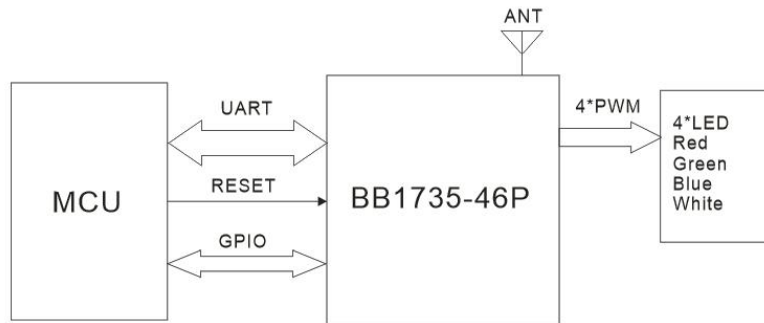

Mesh LED block diagram

4.2 Typical Application Circuit

Mesh LED Sch

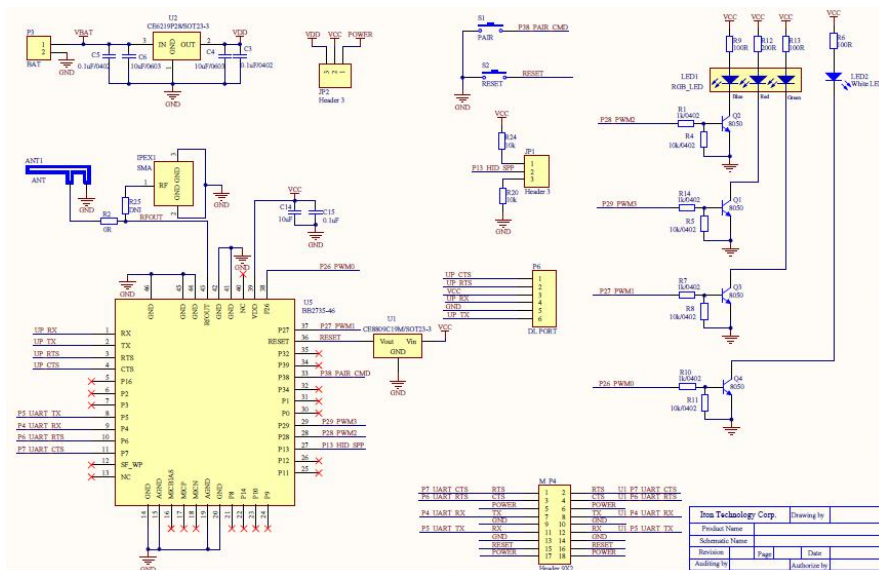

4.3 Layout Guideline

- (1) RF Output Routing Needs 50 Ω Impedance Matching;
- (2) The antenna needs sufficient clearance area

5. Mechanical and Package

5.1 Module Figure



TOP View



Bottom View

5.2 Mechanical Dimension

Unit: mm
Tolerance: $\pm 0.15\text{mm}$

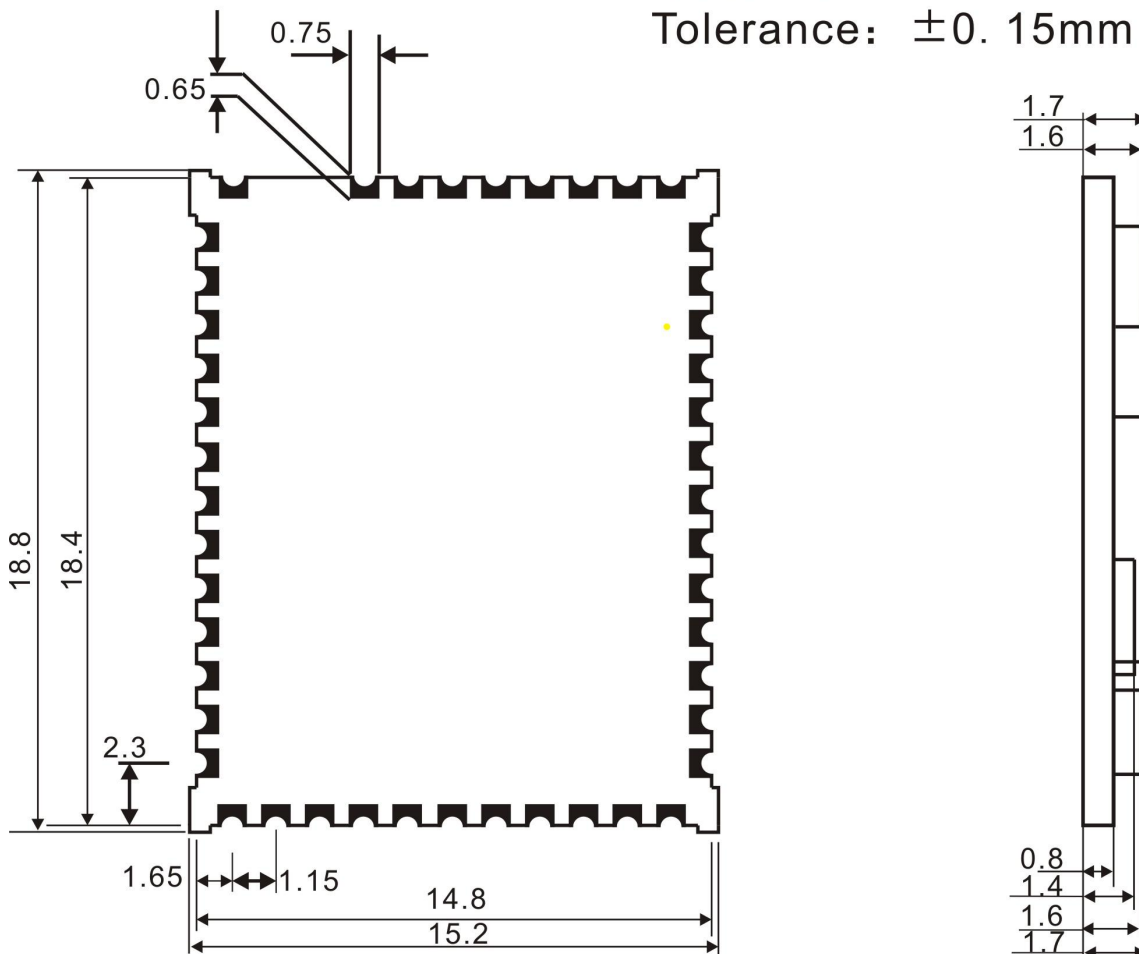

5.3 Packaging Information

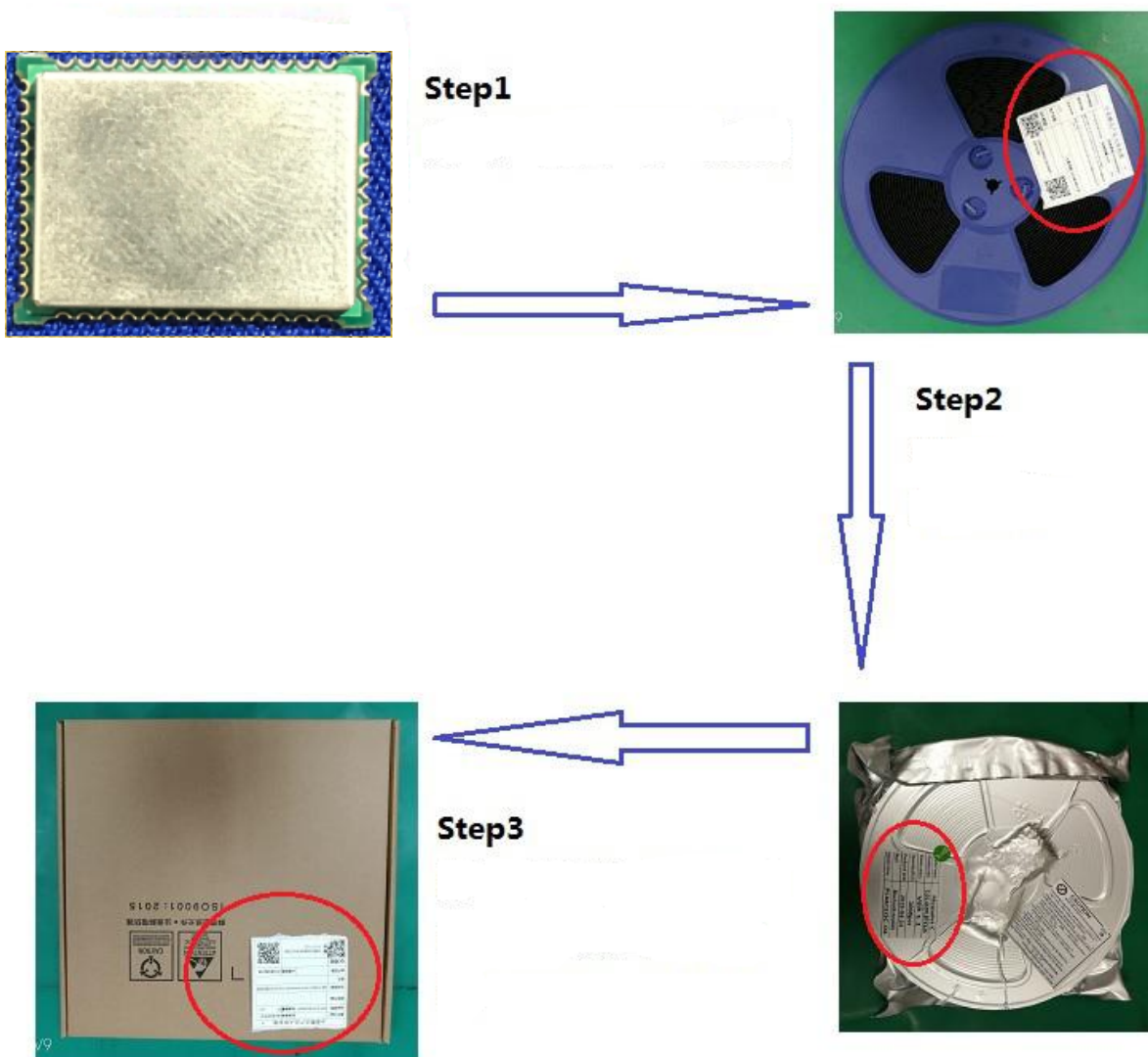

6. Thermal Reflow

Referred to IPC/JEDEC standard.

Peak Temperature: <250°C

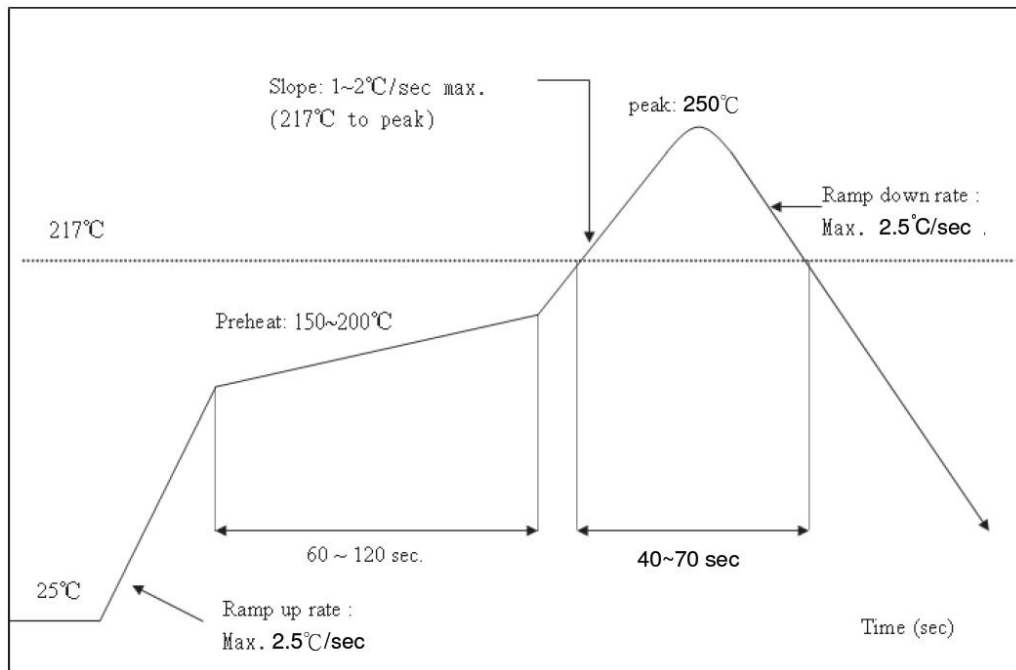

Note: Suggest the module can't be go through the reflow furnace again.

Regulatory Module Integration Instructions

2.2 List of applicable FCC rules

This device complies with part 15.247 of the FCC Rules.

2.3 Summarize the specific operational use conditions

This module can be used in household electrical appliances as well as lighting equipments.

The input voltage to the module should be nominally 1.8 to 3.6V_{DC}, typical value

3.3V_{DC} and the ambient temperature of the module should not exceed 85°C.

The antenna is not field replaceable. If the antenna needs to be changed, the certification should be re-applied.

2.4 Limited module procedures

Not applicable

2.5 Trace antenna designs

Not applicable

2.6 RF exposure considerations

This equipment complies with FCC/ISED radiation exposure limits set forth for an uncontrolled environment.

If the device built into a host as a portable usage, the additional RF exposure evaluation may be required as specified by §2.1093.

2.7 Antennas

The module have a permanently attached antenna.

2.8 Label and compliance information

The outside of final products that contains this module device must display a label referring to the enclosed module. This exterior label can use wording such as: “Contains Transmitter Module FCC ID: 2AABZ-B300D2”, or “Contains FCC ID: 2AABZ-B300D2”, Any similar wording that expresses the same meaning may be used.

2.9 Information on test modes and additional testing requirements

a) The modular transmitter has been fully tested by the module grantee on the required number of channels, modulation types, and modes, it should not be necessary for the host installer to re-test all the available transmitter modes or settings. It is recommended that the host product manufacturer, installing the modular transmitter, perform some investigative measurements to confirm that the resulting composite system does not exceed the spurious emissions limits or band edge limits (e.g., where a different antenna may be causing additional emissions).

b) The testing should check for emissions that may occur due to the intermixing of emissions with the other transmitters, digital circuitry, or due to physical properties of the host product (enclosure). This investigation is especially important when integrating multiple modular transmitters where the certification is based on testing each of them in a stand-alone configuration. It is important to note that host product manufacturers should not assume that because the modular transmitter is certified that they do not

have any responsibility for final product compliance.

c) If the investigation indicates a compliance concern the host product manufacturer is obligated to mitigate the issue. Host products using a modular transmitter are subject to all the applicable individual technical rules as well as to the general conditions of operation in Sections 15.5, 15.15, and 15.29 to not cause interference. The operator of the host product will be obligated to stop operating the device until the interference has been corrected

2.10 Additional testing, Part 15 subpart B disclaimer

The final module combination need to be evaluated against the FCC Part 15B criteria for unintentional radiators in order to be properly authorized for operation as a Part 15 digital device.

The integrator installing this module into their product must ensure that the final composite product complies with the FCC requirements by a technical assessment or evaluation to the FCC rules, including the transmitter operation and should refer to guidance in KDB 996369.

FCC Statement

Any Changes or modifications not expressly approved by the party responsible for compliance could void the user's authority to operate the equipment.

This device complies with part 15 of the FCC Rules. Operation is subject to the following two conditions:

- (1) This device may not cause harmful interference, and
- (2) This device must accept any interference received, including interference that may cause undesired operation.