

# **BTA-QA4020-1**

## **Preliminary Datasheet**

**(Version 01)**

**Issued date: May 7, 2019**

## EnzyTek WiFi<sup>®</sup> Module – BTA-QA4020-1

### OVERVIEW

- ▶ Dual-Band IEEE 802.11a/b/g/n, single stream 1x1
- ▶ BLE5.0
- ▶ ZigBee 15.4
- ▶ Green Tx power saving mode
- ▶ Low-power listen mode
- ▶ Four-layer PCB design
- ▶ Rich set of GPIOs and interface:I2C,HSUART,UART,SPI,QPSI,SDIO2.0,I2S,JTAG,  
SensorADC(up to 8 channel,12bit,1Mmps),Up to 8 PWM optimize for LED lighting application
- ▶ Secure boot and support for application-level AES encryption and image authentication hash  
function(SHA256)
- ▶ USB2.0 interface with integrated controller and PHY for manufacture test and configuration
- ▶ UART host interface to a remote microcontroller with an AT style command set
- ▶ Chipset : Qualcomm QCA4020
- ▶ Memory : 32Mb Nor Flash
- ▶ Operation Voltage : DC\_3.3V
- ▶ Dimension : 33.5 x 28.5 x 3.2 mm
- ▶ Environmental Range : Operation Temperature : -20~+85°C

**System Block Diagram**

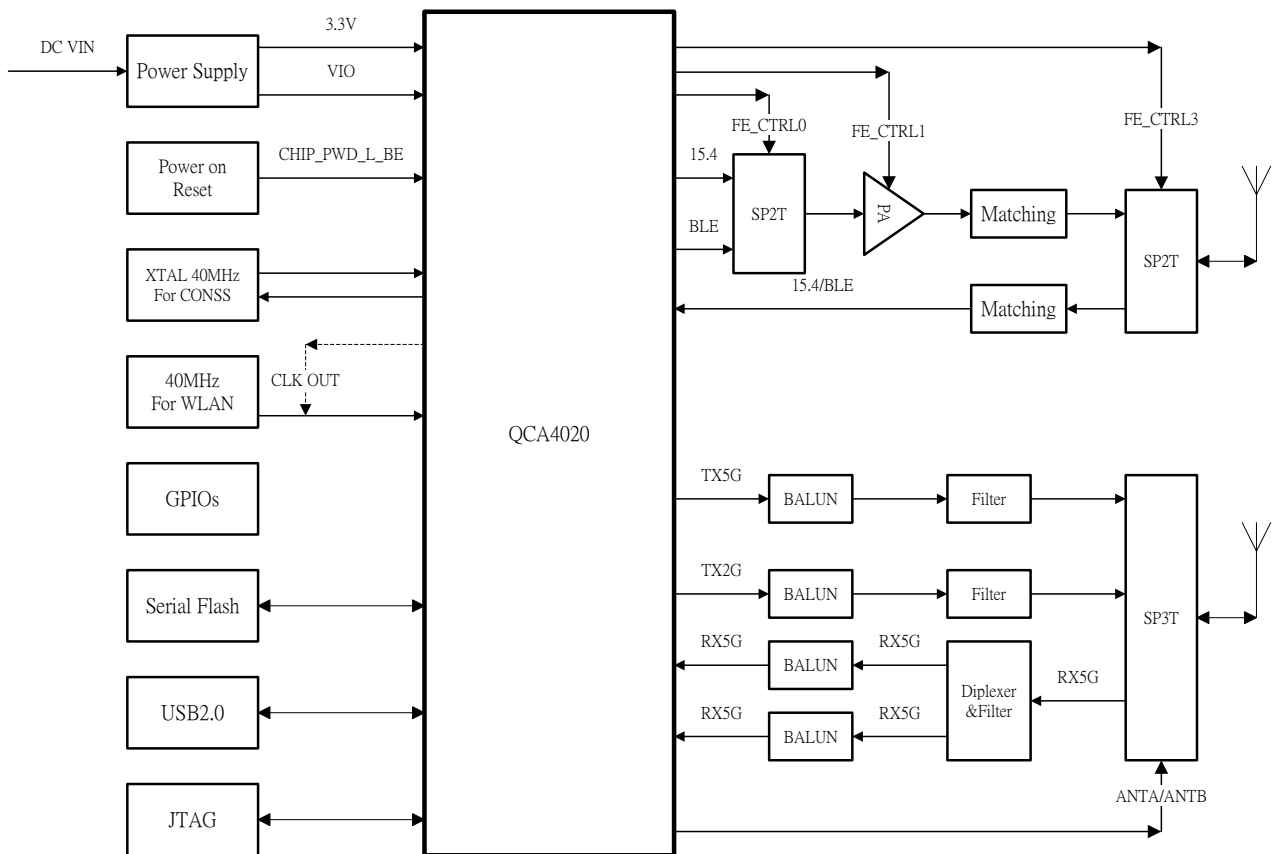



**I/O PIN LISTING**

Pin No.	Pin Name	Type	Description
1	GND	Power	Ground
2	GND	Power	Ground
3	GND	Power	Ground
4	GND	Power	Ground
5	GPIO60_BE	GPIO	Programmable input/output line
6	GPIO6_BE	GPIO	Programmable input/output line
7	GPIO21_WL	TEST PIN	NC
8	GPIO5_BE	GPIO	Programmable input/output line
9	GPIO20_WL	TEST PIN	NC
10	WL_WAKE_UP	DI	NC
11	GPIO19_WL	TEST PIN	NC
12	PWRDWN_OUT_WL	DI	NC
13	GPIO6_WL	TEST PIN	NC
14	GPIO5_WL	TEST PIN	NC
15	GPIO13_WL	TEST PIN	NC
16	GPIO4_WL	TEST PIN	NC
17	GPIO12_WL	TEST PIN	NC
18	GPIO3_WL	TEST PIN	NC
19	GPIO11_WL	TEST PIN	NC
20	GPIO2_WL	TEST PIN	NC
21	GPIO10_WL	TEST PIN	NC
22	GPIO1_WL	TEST PIN	NC
23	IOT_MODE_EN_WL	DI	NC
24	GPIO0_WL	TEST PIN	NC
25	WAKEUP_N_WL	DI	NC
26	GPIO59_BE/ SENSEADC7_BE	GPIO/AI	Can be used as Generic Digital IO or ADC input
27	VDD33	POWER	DC_3.3V Input
28	VDD33	POWER	DC_3.3V Input
29	VDD33	POWER	DC_3.3V Input
30	VDD33	POWER	DC_3.3V Input

31	GPIO58_BE/ SENSEADC6_BE	GPIO/AI	Can be used as Generic Digital IO or ADC input
32	GPIO18_BE	GPIO/PWM_OUT_6/ UART1_CTS	GPIO or PWM or HS_UART
33	GPIO57_BE/ SENSEADC5_BE	GPIO/AI	Can be used as Generic Digital IO or ADC input
34	GPIO19_BE	GPIO/PWM_OUT_1/ UART1_TXD	GPIO or PWM or HS_UART
35	BYPASS_INT_PMU-MSK	DI	NC
36	GPIO20_BE	GPIO/PWM_OUT_2/ UART1_RXD	GPIO or PWM or HS_UART
37	GPIO56_BE/ SENSEADC4_BE	GPIO/AI	Can be used as Generic Digital IO or ADC input
38	GPIO21_BE	GPIO/PWM_OUT_4	GPIO or PWM
39	GPIO55_BE/ SENSEADC3_BE	GPIO/AI	Can be used as Generic Digital IO or ADC input
40	GPIO22_BE	GPIO/PWM_OUT_3	GPIO or PWM
41	GPIO54_BE/ SENSEADC2_BE	GPIO	Can be used as Generic Digital IO or ADC input
42	GPIO23_BE	GPIO/PWM_OUT_5/ UART1_RTS	GPIO or PWM or HS_UART
43	SENSEADC0_BE	AI	ADC Input
44	USB20_DM_BE	AIO	USB D- Pin
45	SENSEADC1_BE	AI	ADC Input
46	USB20_DP_BE	AIO	USB D+ Pin
47	GPIO24_BE	GPIO/JTAG_TCK	GPIO or JTAG
48	GPIO26_BE	GPIO/JTAG_TDO	GPIO or JTAG
49	GPIO25_BE	GPIO/JTAG_TMS	GPIO or JTAG
50	GPIO27_BE	GPIO/JTAG_TDI	GPIO or JTAG
51	CHIP_PWD_L_BE	DI	System Reset (Active Low)
52	GPIO12_BE	GPIO/PWM_OUT_0	GPIO or PWM
53	VIO	POWER	DC_1.8V or DC_3.3V Input
54	VIO	POWER	DC_1.8V or DC_3.3V Input
55	VIO	POWER	DC_1.8V or DC_3.3V Input
56	VIO	POWER	DC_1.8V or DC_3.3V Input

57	GPIO28_BE	GPIO/I2S_BCLK	GPIO or I2S
58	GPIO29_BE	GPIO/I2S_RXD	GPIO or I2S
59	GPIO30_BE	GPIO/I2S_TXD	GPIO or I2S
60	GPIO31_BE	GPIO/I2S_FSYNC	GPIO or I2S
61	GPIO32_BE	GPIO/I2S_MCLK	GPIO or I2S
62	GPIO17_BE	GPIO/I2C1_SDA	GPIO or I2C
63	GPIO15_BE	GPIO	Programmable input/output line
64	GPIO16_BE	GPIO/I2C1_SCL	GPIO or I2C
65	GPIO14_BE	GPIO	Programmable input/output line
66	GPIO13_BE	GPIO	Programmable input/output line
67	GPIO48_BE	GPIO	Programmable input/output line
68	GPIO11_BE	GPIO/I2C0_SDA	GPIO or I2C
69	GPIO53_BE	GPIO	Programmable input/output line
70	GPIO10_BE	GPIO/I2C0_SCL	GPIO or I2C
71	GPIO52_BE	GPIO	Programmable input/output line
72	GPIO9_BE	GPIO/UART0_TX	GPIO or UART
73	GPIO51_BE	GPIO	GPIO
74	GPIO8_BE	GPIO/UART0_RX	GPIO or UART
75	GPIO50_BE	GPIO	Programmable input/output line
76	GPIO7_BE	GPIO	Programmable input/output line
77	GPIO41_BE	GPIO	Programmable input/output line
78	GPIO49_BE	GPIO	Programmable input/output line
79	GND	POWER	Ground
80	GND	POWER	Ground
81	GND	POWER	Ground
82	GND	POWER	Ground
83	GND	POWER	Ground
84	GND	POWER	Ground
85	GND	POWER	Ground
86	GND	POWER	Ground

**Bootstrap signals**

**Bootstrap Mode**

GPIO9_BE	GPIO22_BE	Description
0	0	Force M4 to load image from flash memory (Default)
0	1	Force M4 to boot in EDL (Emergency Download Mode)

**JTAG Mode**

GPIO9_BE	GPIO25_BE	GPIO18_BE	Description
0	0	0	No JTAG enabled
0	0	1	JTAG Pins on GPIO[53:50] _ BE
0	1	0	JTAG Pins on GPIO[11:8] _ BE
0	1	1	JTAG Pins on GPIO[27:24] _ BE (default)
1	X	X	Not Allowed

**XTAL Mode**

GPIO23_BE	Description
0	40MHz Xtal
1	Not Allowed

**32.768KHz Sleep Clock Mode**

GPIO21_BE	GPIO20_BE	Description
0	0	Chip Internal LPO
0	1	External Crystal 32.768KHz
1	0	External 32.768KHz TCXO Clock connected to GPIO_48_BE
1	1	Not Allowed



**Electrical Characteristics**

**Absolute Maximum Ratings :**

	<b>Min.</b>	<b>Typ.</b>	<b>Max.</b>	<b>Unit</b>
Supply Voltage	-0.3	-	4	V
V <sub>IO</sub>	-0.3	-	3.6	V
Storage Temperature	-45	-	125	°C

**Recommend Operation Conditions :**

	<b>Min.</b>	<b>Typ.</b>	<b>Max.</b>	<b>Unit</b>
Supply Voltage	3.14	3.3	3.46	V
V <sub>IO</sub>	3	3.3	3.6	V
V <sub>IL</sub>	-0.3		0.3	V
V <sub>IH</sub>	2.4		3.6	V
V <sub>OL</sub>	-0.3		0.4	V
V <sub>OH</sub>	3		3.3	V
Operating Temperature	-20	-	85	°C

**Dimension**

**Note:** Please contact EnzyTek to get the detail footprint of the module to do the PCB design.

PAD Size: 0.7x0.7 mm

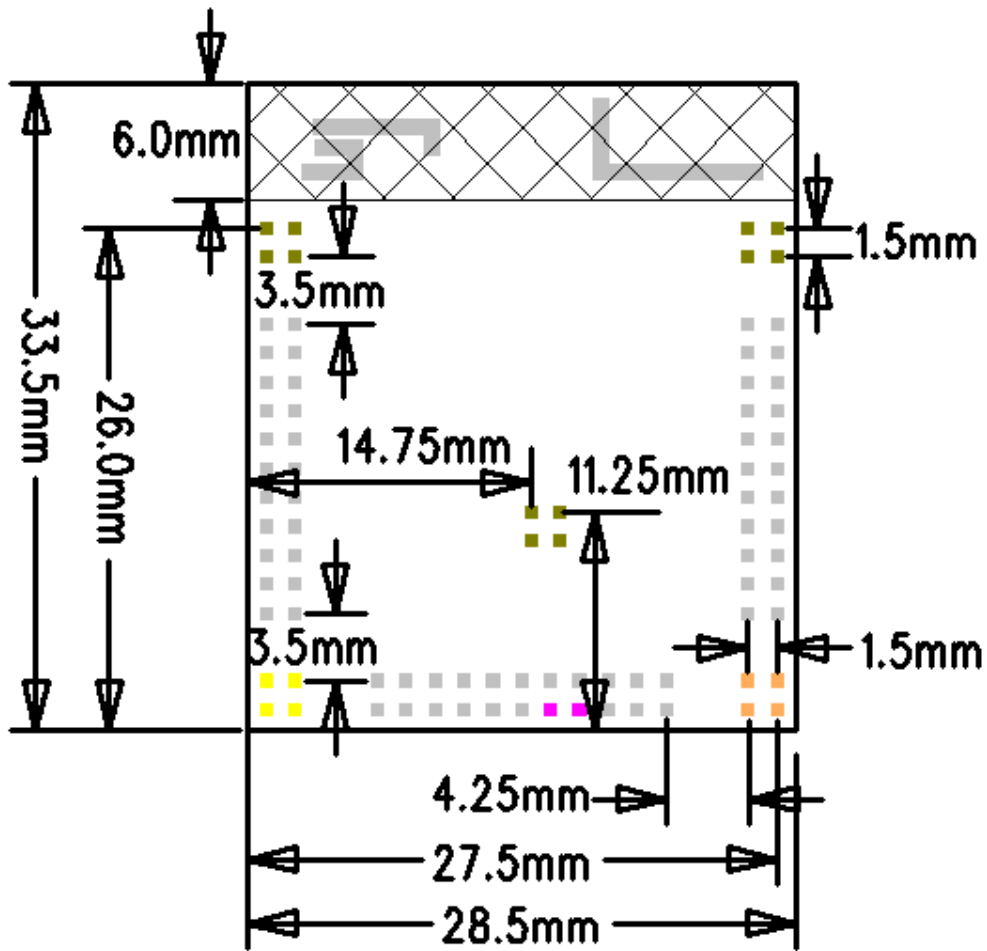

Top View

**Application Circuit**

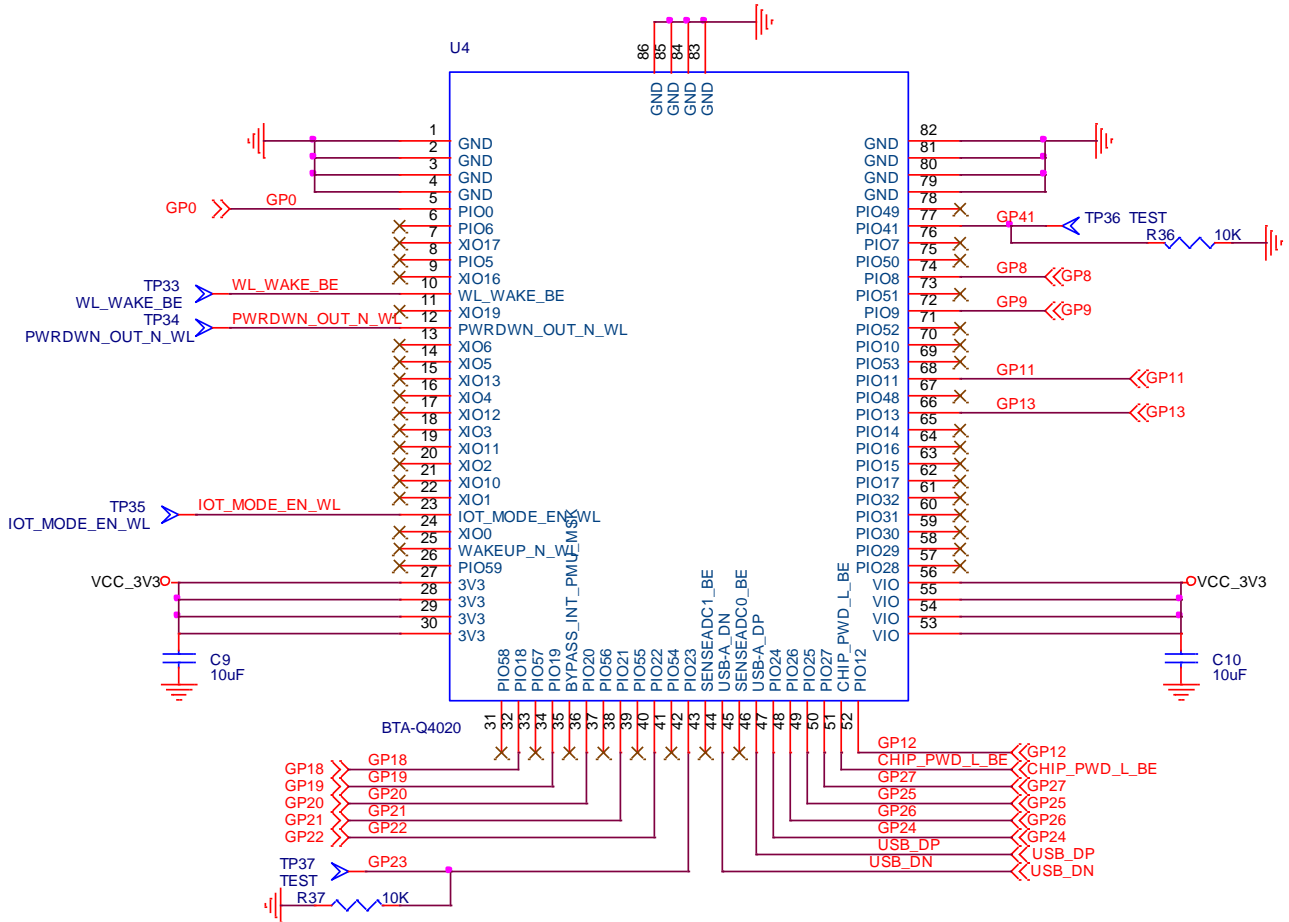

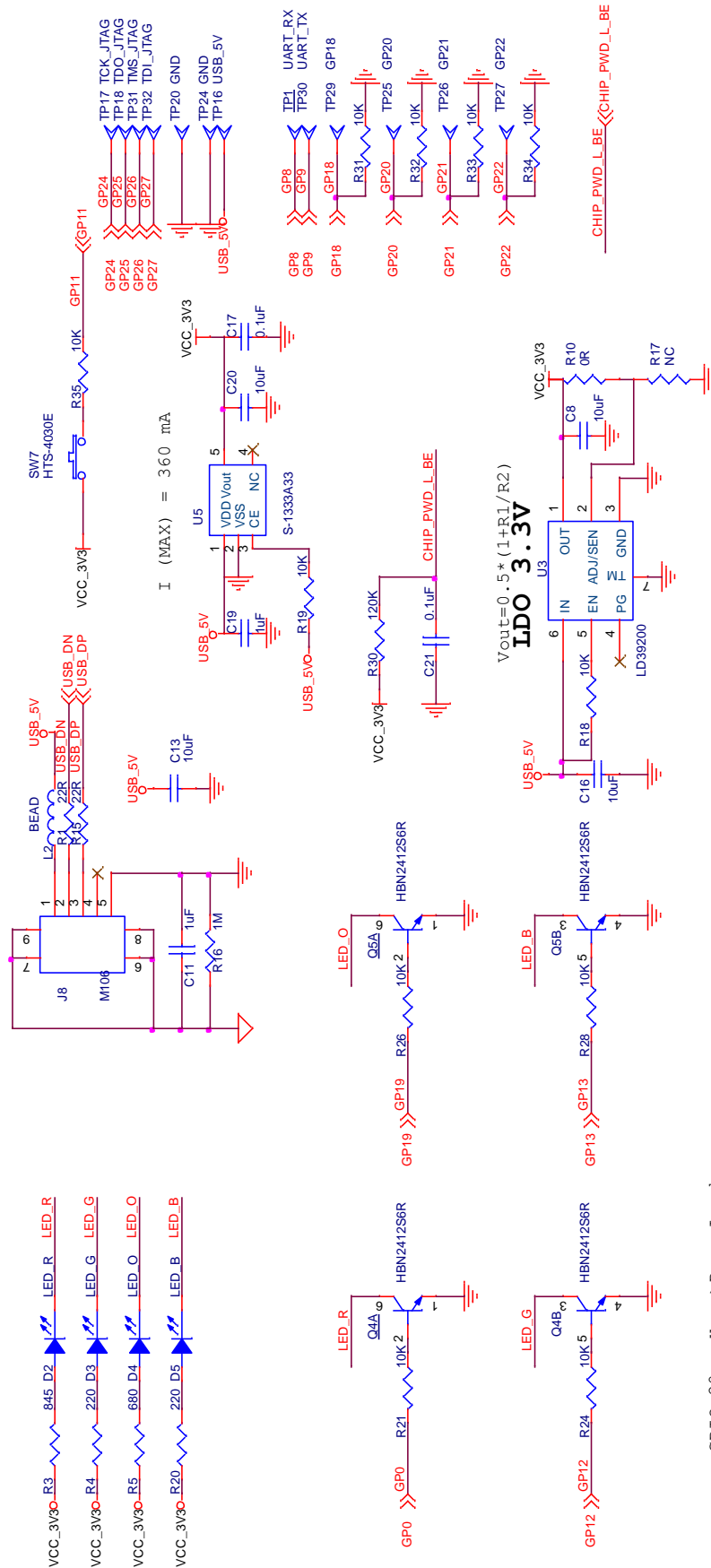

GPIO 20 = H --> Down Load  
GPIO 20 = L --> Normal

GPIO9	GPIO25	GPIO18	
0	1	1	4-Pin JTAG on GPIO27:24

GPIO9	GPIO21	GPIO20	
0	0	0	Internal MCU Ring Oscillator

GPIO22 --> H, USB Download  
GPIO22 --> L, EDL, RF TEST (IQ XEL)

GPIO9	GPIO22	
0	0	Force EDL Boot

## FEDERAL COMMUNICATIONS COMMISSION INTERFERENCE STATEMENT

This equipment has been tested and found to comply with the limits for a Class B digital device, pursuant to part 15 of the FCC Rules. These limits are designed to provide reasonable protection against harmful interference in a residential installation. This equipment generates, uses and can radiate radio frequency energy and, if not installed and used in accordance with the instructions, may cause harmful interference to radio communications. However, there is no guarantee that interference will not occur in a particular installation. If this equipment does cause harmful interference to radio or television reception, which can be determined by turning the equipment off and on, the user is encouraged to try to correct the interference by one or more of the following measures:

- Reorient or relocate the receiving antenna.
- Increase the separation between the equipment and receiver.
- Connect the equipment into an outlet on a circuit different from that to which the receiver is connected.
- Consult the dealer or an experienced radio/ TV technician for help.

### CAUTION:

Any changes or modifications not expressly approved by the grantee of this device could void the user's authority to operate the equipment.

This device complies with Part 15 of the FCC Rules. Operation is subject to the following two conditions: (1) this device may not cause harmful interference, and (2) this device must accept any interference received, including interference that may cause undesired operation.

### RF exposure warning :

This equipment must be installed and operated in accordance with provided instructions and the antenna(s) used for this transmitter must be installed to provide a separation distance of at least 20 cm from all persons and must not be co-located or operating in conjunction with any other antenna or transmitter. End-users and installers must be provide with antenna installation instructions and transmitter operating conditions for satisfying RF exposure compliance.

### End Product Labeling

This transmitter module is authorized only for use in device where the antenna may be installed such that 20cm may be maintained between the antenna and users. The final end product must be labeled in a visible area with the following: "Contains FCC ID: 2AABGQ4020-1M " and "Contains IC: 25041-Q40201M "

### Information for the OEMs and Integrators

The following statement must be included with all versions of this document supplied to an OEM or integrator, but should not be distributed to the end user.

- 1) This device is intended for OEM integrators only.
- 2) Please see the full Grant of Equipment document for other restrictions.

### Canada, Industry Canada (IC) Notices

This device complies with Canada licence-exempt RSS standard(s).

Operation is subject to the following two conditions: (1) this device may not cause interference, and (2) this device must accept any interference, including interference that may cause undesired operation of the device.

### Canada, avis d'Industry Canada (IC)

Cet appareil est conforme avec Industrie Canada exemptes de licence RSS standard(s).

Son fonctionnement est soumis aux deux conditions suivantes : (1) cet appareil ne doit pas causer d'interférence et (2) cet appareil doit accepter toute interférence, notamment les interférences qui peuvent affecter son fonctionnement.

### Radio Frequency (RF) Exposure Information

The radiated output power of the Wireless Device is below the Industry Canada (IC) radio frequency exposure limits. The Wireless Device should be used in such a manner such that the potential for human contact during normal operation is minimized.

This device has also been evaluated and shown compliant with the IC RF Exposure limits under mobile exposure conditions. (antennas are greater than 20cm from a person's body).

### Informations concernant l'exposition aux fréquences radio (RF)

La puissance de sortie émise par l'appareil de sans fil est inférieure à la limite d'exposition aux fréquences radio d'Industry Canada (IC). Utilisez l'appareil de sans fil de façon à minimiser les contacts humains lors du fonctionnement normal.

Ce périphérique a également été évalué et démontré conforme aux limites d'exposition aux RF d'IC dans des conditions d'exposition à des appareils mobiles (antennes sont supérieures à 20 cm à partir du corps d'une personne).

### Caution:

the device for operation in the band 5150 – 5250 MHz is only for indoor use to reduce the potential for harmful interference to co-channel mobile satellite systems;

les dispositifs fonctionnant dans la bande de 5150 à 5250 MHz sont réservés uniquement pour une utilisation à l'intérieur afin de réduire les risques de brouillage préjudiciable aux systèmes de satellites mobiles utilisant les mêmes canaux