



MEASUREMENT REPORT

FCC PART 15 Subpart E & IC RSS-247

WLAN 802.11a/n

FCC ID: 2AABGQ4020-1M
IC: 25041-Q40201M
APPLICANT: EnzyTek Technology Inc
Application Type: Certification
Product: Wireless module
Model No.: BTA-QA4020-1
FCC Classification: Unlicensed National Information Infrastructure (UNII)
FCC Rule Part(s): Part 15 Subpart E (Section 15.407)
IC Standard: RSS-247 Issue 2
Test Procedure(s): ANSI C63.10-2013, KDB 789033 D02v02r01,
KDB 662911 D01v02r01
Received Date: April 10, 2019
Test Date: April 15, 2019 ~ June 12, 2019

Tested By : *Peter Syu*
(Peter Syu)
Reviewed By : *Paddy Chen*
(Paddy Chen)
Approved By : *Chenz Ker*
(Chenz Ker)



The test results relate only to the samples tested.

This equipment has been shown to be capable of compliance with the applicable technical standards as indicated in the measurement report and was tested in accordance with the measurement procedures specified in KDB 789033 D02v02r01. Test results reported herein relate only to the item(s) tested.

The test report shall not be reproduced except in full without the written approval of MRT Technology (Taiwan) Co., Ltd.

Revision History

Report No.	Version	Description	Issue Date	Note
1904TW0501-U4	1.0	Original Report	2019-06-19	

CONTENTS

Description	Page
§2.1033 General Information	5
1. INTRODUCTION.....	6
1.1. Scope.....	6
1.2. MRT Test Location	6
2. PRODUCT INFORMATION	7
2.1. Equipment Description	7
2.2. Operation Frequencies and Channel List	8
2.3. Test Mode	8
2.4. Test Software	8
2.5. Device Capabilities.....	9
2.6. Test Configuration	9
2.7. EMI Suppression Device(s)/Modifications	9
2.8. Labeling Requirements	9
3. DESCRIPTION OF TEST	10
3.1. Evaluation Procedure	10
3.2. AC Line Conducted Emissions	10
3.3. Radiated Emissions.....	11
4. ANTENNA REQUIREMENTS.....	12
5. TEST EQUIPMENT CALIBRATION DATE.....	13
6. MEASUREMENT UNCERTAINTY.....	14
7. TEST RESULT	15
7.1. Summary.....	15
7.2. Occupied Bandwidth Measurement.....	16
7.2.1. Test Limit.....	16
7.2.2. Test Procedure used	16
7.2.3. Test Setting	16
7.2.4. Test Setup	16
7.2.5. Test Result	17
7.3. 6dB Bandwidth Measurement	21
7.3.1. Test Limit.....	21
7.3.2. Test Procedure used	21
7.3.3. Test Setting	21

7.3.4.	Test Setup	21
7.3.5.	Test Result	22
7.4.	Output Power Measurement.....	25
7.4.1.	Test Limit.....	25
7.4.2.	Test Procedure Used.....	26
7.4.3.	Test Setting	27
7.4.4.	Test Setup	27
7.4.5.	Test Result	28
7.5.	Transmit Power Control.....	32
7.5.1.	Test Limit.....	32
7.5.2.	Test Procedure Used.....	32
7.5.3.	Test Setting	32
7.5.4.	Test Setup	32
7.5.5.	Test Result	33
7.6.	Power Spectral Density Measurement.....	34
7.6.1.	Test Limit.....	34
7.6.2.	Test Procedure Used.....	34
7.6.3.	Test Setting	35
7.6.4.	Test Setup	35
7.6.5.	Test Result	36
7.7.	Radiated Spurious Emission Measurement	40
7.7.1.	Test Limit.....	40
7.7.2.	Test Procedure Used.....	40
7.7.3.	Test Setting	40
7.7.4.	Test Setup	42
7.7.5.	Test Result	44
7.8.	Radiated Restricted Band Edge Measurement.....	78
7.8.1.	Test Limit.....	78
7.8.2.	Test Result	81
7.9.	AC Conducted Emissions Measurement	99
7.9.1.	Test Limit.....	99
7.9.2.	Test Procedure	99
7.9.3.	Test Setup	100
7.9.4.	Test Result	101
8.	CONCLUSION	103

§2.1033 General Information

Applicant	EnzyTek Technology Inc
Applicant Address	7F., No.35, Hsueh Fu Rd., Hsinchu 300, Taiwan, R.O.C.
Manufacturer	EnzyTek Technology Inc
Manufacturer Address	7F., No.35, Hsueh Fu Rd., Hsinchu 300, Taiwan, R.O.C.
Test Site	MRT Technology (Taiwan) Co., Ltd
Test Site Address	No. 38, Fuxing Second Rd., Guishan Dist., Taoyuan City 333, Taiwan (R.O.C)
MRT FCC Registration No.	291082
FCC Rule Part(s)	Part 15 Subpart E (Section 15.407)
IC Standard:	RSS-247 Issue 2
Model No.	BTA-QA4020-1
Test Device Serial No.	N/A <input type="checkbox"/> Production <input checked="" type="checkbox"/> Pre-Production <input type="checkbox"/> Engineering
FCC Classification	Unlicensed National Information Infrastructure (UNII)

Test Facility / Accreditations

Measurements were performed at MRT Laboratory located in Fuxing Rd., Taoyuan, Taiwan (R.O.C)

- MRT facility is a FCC registered (Reg. No. 291082) test facility with the site description report on file and is designated by the FCC as an Accredited Test Firm.
- MRT facility is an IC registered (MRT Reg. No. 21723) test laboratory with the site description on file at Industry Canada.
- MRT Lab is accredited to ISO 17025 by the Taiwan Accreditation Foundation (TAF Cert. No. 3261) in EMC, Telecommunications and Radio testing for FCC (Designation Number: TW3261), Industry Taiwan, EU and TELEC Rules.

1. INTRODUCTION

1.1. Scope

Measurement and determination of electromagnetic emissions (EMC) of radio frequency devices including intentional and/or unintentional radiators for compliance with the technical rules and regulations of the Federal Communications Commission and the Industry Canada Certification and Engineering Bureau.

1.2. MRT Test Location

The map below shows the location of the MRT LABORATORY, its proximity to the Taoyuan City. These measurement tests were conducted at the MRT Technology (Taiwan) Co., Ltd. Facility located at No.38, Fuxing 2nd Rd., Guishan Dist., Taoyuan City 33377, Taiwan (R.O.C).

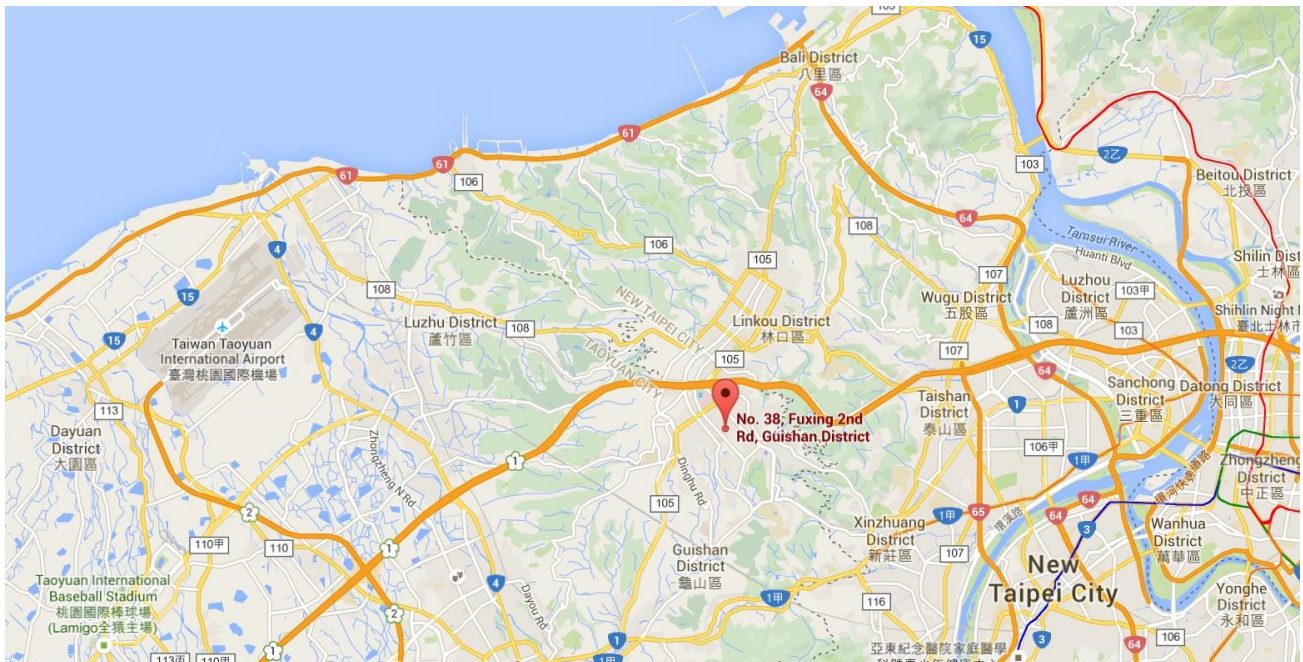

2. PRODUCT INFORMATION

2.1. Equipment Description

Product Name	Wireless module
Model No.	BTA-QA4020-1
Brand Name	EnzyTek
Supports Radios Spec.	2.4G: 802.11b/g/n-20/n-40 5G: 802.11a/n-20/n-40, Band 1,4 BLE 5.0 ZigBee 15.4
Wi-Fi Specification	802.11a/b/g/n
Frequency Range	<p>2.4GHz: For 802.11b/g/n-HT20: 2412 ~ 2462 MHz For 802.11n-HT40: 2422 ~ 2452 MHz</p> <p>5GHz: For 802.11a/n-HT20: 5180~5240MHz, 5745MHz~5825MHz For 802.11n-HT40: 5190~5230MHz, 5755MHz~5795MHz</p>
Maximum Output Power	802.11a: 12.71dBm 802.11n-HT20: 13.19dBm 802.11n-HT40: 12.39dBm
Modulation Type	802.11a/n-20/n-40: OFDM (BPSK, QPSK, 16QAM, 64QAM,256QAM)

2.2. Operation Frequencies and Channel List

802.11 a/ n-HT20

Channel	Frequency	Channel	Frequency	Channel	Frequency
36	5180 MHz	40	5200 MHz	44	5220 MHz
48	5240 MHz	149	5745 MHz	153	5765 MHz
157	5785 MHz	161	5805 MHz	165	5825 MHz

802.11 n-HT40

Channel	Frequency	Channel	Frequency	Channel	Frequency
38	5190 MHz	46	5230 MHz	151	5755 MHz
159	5795 MHz	--	--	--	--

2.3. Test Mode

Test Mode	Mode 1: Transmit by 802.11a
	Mode 2: Transmit by 802.11n-HT20
	Mode 3: Transmit by 802.11n-HT40

2.4. Test Software

The test utility software used during testing was “QDART”.

2.5. Device Capabilities

This device contains the following capabilities:

2.4GHz WLAN (DTS) and 5GHz WLAN (NII).

Note: 5GHz (NII) operation is possible in 20MHz, 40MHz channel bandwidths. The maximum achievable duty cycles for all modes were determined based on measurements performed on a spectrum analyzer in zero-span mode with RBW = 8MHz, VBW = 50MHz, and detector = average per the guidance of Section B)2)b) of KDB 789033 D02v02r01. The RBW and VBW were both greater than $50/T$, where T is the minimum transmission duration, and the number of sweep points across T was greater than 100. The duty cycles are as follows:

Test Mode	Duty Cycle
802.11a	100%
802.11n-HT20	100%
802.11n-HT40	100%

2.6. Test Configuration

This device was tested per the guidance of KDB 789033 D02v02r01. ANSI C63.10-2013 was used to reference the appropriate EUT setup for radiated spurious emissions testing and AC line conducted testing.

2.7. EMI Suppression Device(s)/Modifications

No EMI suppression device(s) were added and/or no modifications were made during testing.

2.8. Labeling Requirements

Per 2.1074 & 15.19; Docket 95-19

The label shall be permanently affixed at a conspicuous location on the device; instruction manual or pamphlet supplied to the user and be readily visible to the purchaser at the time of purchase.

However, when the device is so small wherein placement of the label with specified statement is not practical, only the FCC ID must be displayed on the device per Section 15.19(a)(5). Please see attachment for FCC ID label and label location.

3. DESCRIPTION OF TEST

3.1. Evaluation Procedure

The measurement procedures described in the American National Standard for Testing Unlicensed Wireless Devices (ANSI C63.10-2013), and the guidance provided in KDB 789033 were used in the measurement of the device.

Deviation from measurement procedure.....None

3.2. AC Line Conducted Emissions

The line-conducted facility is located inside an 9'x4'x3' shielded enclosure. A 1m x 2m wooden table 80cm high is placed 40cm away from the vertical wall and 80cm away from the sidewall of the shielded room. Two 10kHz-30MHz, 50Ω/50uH Line-Impedance Stabilization Networks (LISNs) are bonded to the shielded room floor. Power to the LISNs is filtered by external high-current high-insertion loss power line filters. These filters attenuate ambient signal noise from entering the measurement lines. These filters are also bonded to the shielded enclosure.

The EUT is powered from one LISN and the support equipment is powered from the second LISN. All interconnecting cables more than 1 meter were shortened to a 1 meter length by non-inductive bundling (serpentine fashion) and draped over the back edge of the test table. All cables were at least 40cm above the horizontal reference ground-plane. Power cables for support equipment were routed down to the second LISN while ensuring that that cables were not draped over the second LISN.

Sufficient time for the EUT, support equipment, and test equipment was allowed in order for them to warm up to their normal operating condition. The RF output of the LISN was connected to the receiver and exploratory measurements were made to determine the frequencies producing the maximum emission from the EUT. The receiver was scanned from 150kHz to 30MHz. The detector function was set to peak mode for exploratory measurements while the bandwidth of the analyzer was set to 9kHz. The EUT, support equipment, and interconnecting cables were arranged and manipulated to maximize each emission. Each emission was also maximized by varying: power lines, the mode of operation or data exchange speed, or support equipment whichever determined the worst-case emission. Once the worst case emissions have been identified, the one EUT cable configuration/arrangement and mode of operation that produced these emissions are used for final measurements on the same test site. The analyzer is set to CISPR quasi-peak and average detectors with a 9kHz resolution bandwidth for final measurements.

An extension cord was used to connect to a single LISN which powered by EUT. The extension cord was calibrated with LISN, the impedance and insertion loss are compliance with the requirements as stated in ANSI C63.10-2013.

Line conducted emissions test results are shown in Section 7.10.

3.3. Radiated Emissions

The radiated test facilities consisted of an indoor 3 meter semi-anechoic chamber used for final measurements and exploratory measurements, when necessary. The measurement area is contained within the semi-anechoic chamber which is shielded from any ambient interference. For measurements above 1GHz absorbers are arranged on the floor between the turn table and the antenna mast in such a way so as to maximize the reduction of reflections. For measurements below 1GHz, the absorbers are removed. A turntable is used for radiated measurement. It is a continuously rotatable, remote controlled, metallic turntable and 2 meters (6.56 ft.) in diameter. The turn table is flush with the raised floor of the chamber in order to maintain its function as a ground plane. An 80cm high PVC support structure is placed on top of the turntable.

For all measurements, the spectrum was scanned through all EUT azimuths and from 1 to 4 meter receive antenna height using a broadband antenna from 30MHz up to the upper frequency shown in 15.33(b)(1) depending on the highest frequency generated or used in the device or on which the device operates or tunes. For frequencies above 1GHz, linearly polarized double ridge horn antennas were used. For frequencies below 30MHz, a calibrated loop antenna was used. When exploratory measurements were necessary, they were performed at 1 meter test distance inside the semi-anechoic chamber using broadband antennas, broadband amplifiers, and spectrum analyzers to determine the frequencies and modes producing the maximum emissions. Sufficient time for the EUT, support equipment, and test equipment was allowed in order for them to warm up to their normal operating condition. The test set-up for frequencies below 1GHz was placed on top of the 0.8 meter high, 1 x 1.5 meter table; and test set-up for frequencies 1-40GHz was placed on top of the 1.5 meter high, 1 x 1.5 meter table. The EUT, support equipment, and interconnecting cables were arranged and manipulated to maximize each emission. Appropriate precaution was taken to ensure that all emissions from the EUT were maximized and investigated. The system configuration, clock speed, mode of operation or video resolution, if applicable, turntable azimuth, and receive antenna height was noted for each frequency found.

Final measurements were made in the semi-anechoic chamber using calibrated, linearly polarized broadband and horn antennas. The test setup was configured to the setup that produced the worst case emissions. The spectrum analyzer was set to investigate all frequencies required for testing to compare the highest radiated disturbances with respect to the specified limits. The turntable containing the EUT was rotated through 360 degrees and the height of the receive antenna was varied 1 to 4 meters and stopped at the azimuth and height producing the maximum emission. Each emission was maximized by changing the orientation of the EUT through three orthogonal planes and changing the polarity of the receive antenna, whichever produced the worst-case emissions. According to 3dB Beam-Width of horn antenna, the horn antenna should be always directed to the EUT when rising height.

4. ANTENNA REQUIREMENTS

Excerpt from §15.203 of the FCC Rules/Regulations:

“An intentional radiator antenna shall be designed to ensure that no antenna other than that furnished by the responsible party can be used with the device. The use of a permanently attached antenna or of an antenna that uses a unique coupling to the intentional radiator shall be considered sufficient to comply with the provisions of this section.”

- The antenna of the **Wireless module**, is permanently attached.
- There are no provisions for connection to an external antenna.

Conclusion:

The EUT unit complies with the requirement of §15.203.

Antenna List

No.	Manufacturer	Part No.	Antenna Type	Peak Gain
1	EnzyTek Technoloy Inc.	BTA-QA4020-1	PCB	-2.07dBi

5. TEST EQUIPMENT CALIBRATION DATE

Conducted Emissions – SR2

Instrument	Manufacturer	Type No.	Asset No.	Cali. Interval	Cali. Due Date
Two-Line V-Network	R&S	ENV216	MRTTWA00019	1 year	2020/4/25
Cable	Rosnol	N1C50-RG400-B 1C50-500CM	MRTTWE00013	1 year	2019/6/21
EMI Test Receiver	R&S	ESR3	MRTTWA00009	1 year	2020/3/25

Radiated Emissions – AC1

Instrument	Manufacturer	Type No.	Asset No.	Cali. Interval	Cali. Due Date
Broadband TRILOG Antenna	SCHWARZBECK	VULB 9162	MRTTWA00001	1 year	2020/6/4
EMI Test Receiver	R&S	ESR3	MRTTWA00009	1 year	2020/3/25
Active Loop Antenna	Schwarzbeck	FMZB 1519B	MRTTWA00002	1 year	2020/4/29
Broadband Horn antenna	SCHWARZBECK	BBHA 9120D	MRTTWA00003	1 year	2020/4/22
Breitband Hornantenna	Schwarzbeck	BBHA 9170	MRTTWA00004	1 year	2020/4/23
Broadband Amplifier	Schwarzbeck	BBV 9721	MRTTWA00006	1 year	2020/4/24
Broadband Preampfier	SCHWARZBECK	BBV 9718	MRTTWA00005	1 year	2020/4/24
Cable	HUBERSUHNER	SF106	MRTTWA00010	1 year	2019/6/18
Cable	Rosnol	K1K50-UP0264- K1K50-4M	MRTTWA00012	1 year	2019/7/30

Conducted Test Equipment – SR2

Instrument	Manufacturer	Type No.	Asset No.	Cali. Interval	Cali. Due Date
Spectrum Analyzer	KEYSIGHT	N9010A	MRTTWA00012	1 year	2019/7/30
USB Wideband Power Sensor	KEYSIGHT	U2021XA	MRTTWA00015	1 year	2020/3/26

Test Software

Software	Version	Function
e3	9.160520a	EMI Test Software
EMI	V3	EMI Test Software

6. MEASUREMENT UNCERTAINTY

Where relevant, the following test uncertainty levels have been estimated for tests performed on the EUT as specified in CISPR 16-4-2. This uncertainty represents an expanded uncertainty expressed at approximately the 95% confidence level using a coverage factor of $k = 2$.

Conducted Emission- Power Line	
Measuring Uncertainty for a Level of Confidence of 95% ($U=2Uc(y)$):	2.53dB
Conducted Emission- Impedance Stabilization Network Measurement	
Measuring Uncertainty for a Level of Confidence of 95% ($U=2Uc(y)$):	3.96dB
Radiated Spurious Emission	
Measuring Uncertainty for a Level of Confidence of 95% ($U=2Uc(y)$):	3.92dB (Below 30M)
Measuring Uncertainty for a Level of Confidence of 95% ($U=2Uc(y)$):	4.25dB (30M~1G)
Measuring Uncertainty for a Level of Confidence of 95% ($U=2Uc(y)$):	4.40dB (1G~18G)
Measuring Uncertainty for a Level of Confidence of 95% ($U=2Uc(y)$):	4.45dB (18G~40G)
Frequency Error	
Measuring Uncertainty for a Level of Confidence of 95% ($U=2Uc(y)$):	$\pm 78.4\text{Hz}$
Conducted Power	
Measuring Uncertainty for a Level of Confidence of 95% ($U=2Uc(y)$):	$\pm 0.84\text{dB}$
Conducted Spurious Emission	
Measuring Uncertainty for a Level of Confidence of 95% ($U=2Uc(y)$):	$\pm 2.65\text{ dB}$
Occupied Bandwidth	
Measuring Uncertainty for a Level of Confidence of 95% ($U=2Uc(y)$):	3.3%
Temp. / Humidity	
Measuring Uncertainty for a Level of Confidence of 95% ($U=2Uc(y)$):	$\pm 0.82^\circ\text{C}/ \pm 3\%$
DC Voltage	
Measuring Uncertainty for a Level of Confidence of 95% ($U=2Uc(y)$):	$\pm 0.3\%$

7. TEST RESULT

7.1. Summary

Company Name: Wireless module

6Mbps ~ 54Mbps (a):

Data Rate(s) Tested: **6.5/7.2Mbps ~ 65/72.2Mbps (n-HT20):**

13.5/15.0Mbps ~ 135/150Mbps (n-HT40):

FCC Section(s)	IC Section(s)	Test Description	Test Limit	Test Condition	Test Result	Reference
15.407(a)	RSS-247 §6.2	26dB/ 99% Bandwidth	N/A	Conducted	Pass	Section 7.2
15.407(e)	RSS-247 §6.2.4	6dB Bandwidth	≥ 500kHz		Pass	Section 7.3
15.407(a)	RSS-247 §6.2	Maximum Conducted Output Power	Refer to Section 7.5		Pass	Section 7.5
15.407(h)(1)	RSS-247 §6.2.2, §6.2.3	Transmit Power Control	≤ 24 dBm		N/A	Section 7.6
15.407(a)	RSS-247 §6.2	Power Spectral Density	Refer to Section 7.7		Pass	Section 7.7
15.407(b)(1), (4)	RSS-247 §6.2	Undesirable Emissions	≤ -27dBm/MHz EIRP ≤ -17dBm/MHz EIRP	Radiated	Pass	Section 7.8 & 7.9
15.205, 15.209, 15.407(b)(5), (6), (7)	RSS-247 §6.2	General Field Strength Limits (Restricted Bands and Radiated Emission Limits)	Emissions in restricted bands must meet the radiated limits detailed in 15.209		Pass	
15.207	RSS-Gen 8.8	AC Conducted Emissions 150kHz - 30MHz	< FCC 15.207 limits	Line Conducted	Pass	Section 7.10

Notes:

- 1) Determining compliance is based on the test results met the regulation limits or requirements declared by clients, and the test results don't take into account the value of measurement uncertainty.
- 2) All channels, modes, and modulations/data rates were investigated among all UNII bands. The test results shown in the following sections represent the worst case emissions.
- 3) The analyzer plots shown in this section were all taken with a correction table loaded into the analyzer. The correction table was used to account for the losses of the cables and attenuators used as part of the system to connect the EUT to the analyzer at all frequencies of interest.

7.2. Occupied Bandwidth Measurement

7.2.1. Test Limit

N/A

7.2.2. Test Procedure used

ANSI C63.10 6.9.3 / RSS-Gen 6.7

7.2.3. Test Setting

1. The analyzers' automatic bandwidth measurement capability was used to perform the 26dB bandwidth measurement. The "X" dB bandwidth parameter was set to $X = 26$. The automatic bandwidth measurement function also has the capability of simultaneously measuring the 99% occupied bandwidth. The bandwidth measurement was not influenced by any intermediated power nulls in the fundamental emission.
2. RBW = approximately 1% of the emission bandwidth.
3. VBW $\geq 3 \times$ RBW.
4. Detector = Peak.
5. Trace mode = max hold.

7.2.4. Test Setup

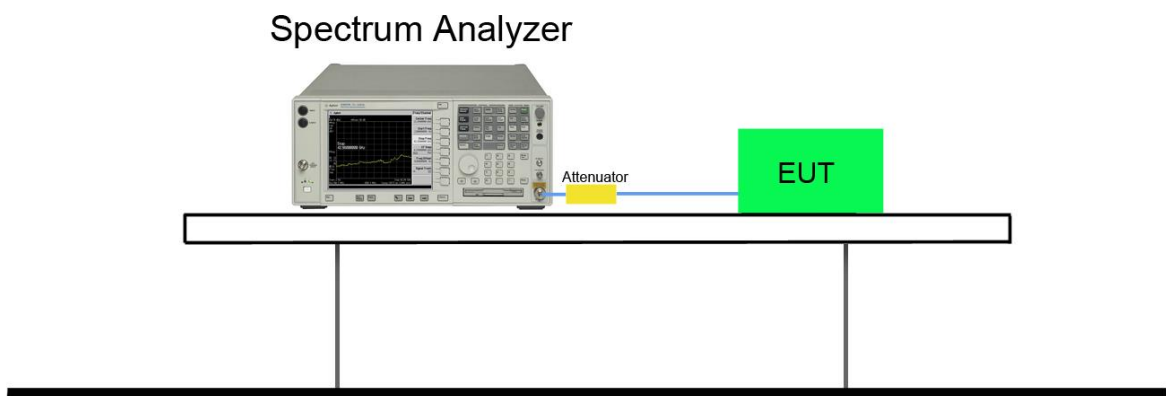

7.2.5. Test Result

Test Mode	Channel No.	Frequency (MHz)	26dB Bandwidth (MHz)	99% Bandwidth (MHz)
802.11a	36	5180	19.880	16.450
802.11a	44	5220	20.610	16.459
802.11a	48	5240	20.680	16.493
802.11a	149	5745	20.060	16.460
802.11a	157	5785	21.980	16.612
802.11a	165	5825	20.540	16.464
802.11n-HT20	36	5180	21.220	17.650
802.11n-HT20	44	5220	20.720	17.649
802.11n-HT20	48	5240	21.770	17.606
802.11n-HT20	149	5745	21.370	17.663
802.11n-HT20	157	5785	21.440	17.638
802.11n-HT20	165	5825	21.370	17.661
802.11n-HT40	38	5190	40.090	35.569
802.11n-HT40	46	5230	40.060	35.614
802.11n-HT40	151	5755	42.150	35.830
802.11n-HT40	159	5795	42.320	35.741

802.11a 26dB Bandwidth & 99% Bandwidth

Channel 36 (5180MHz)

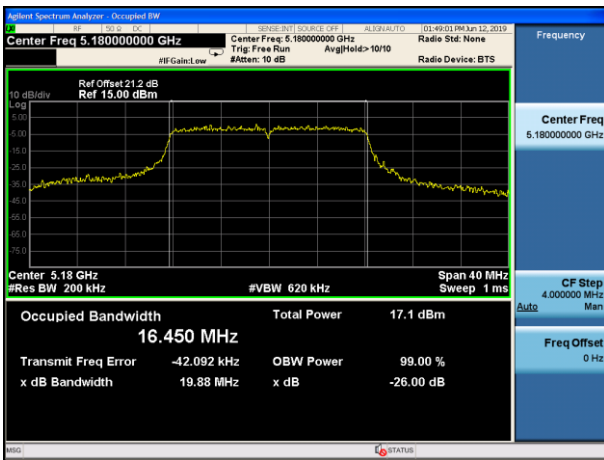

Channel 44 (5220MHz)

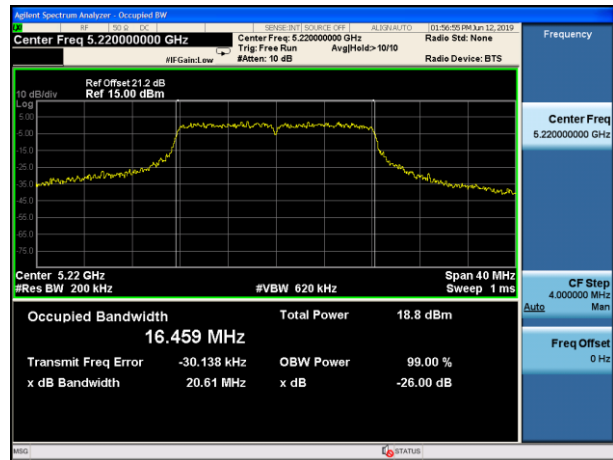

Channel 48 (5240MHz)

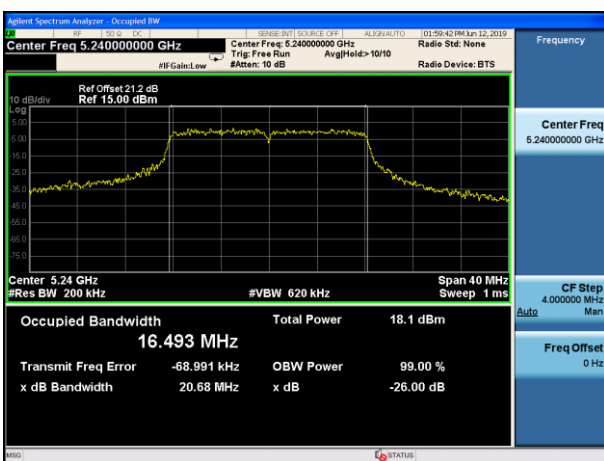

Channel 149 (5745MHz)

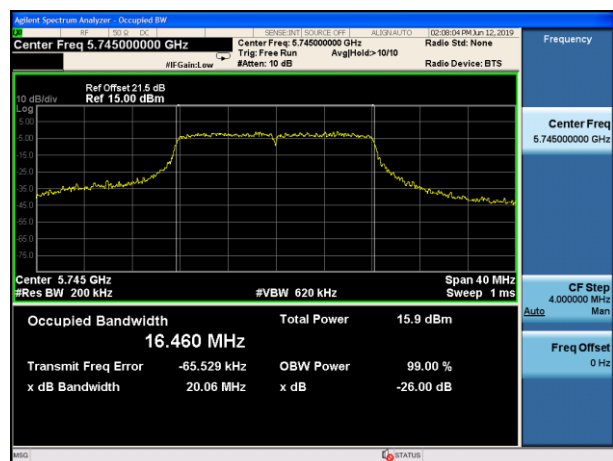

Channel 157 (5785MHz)

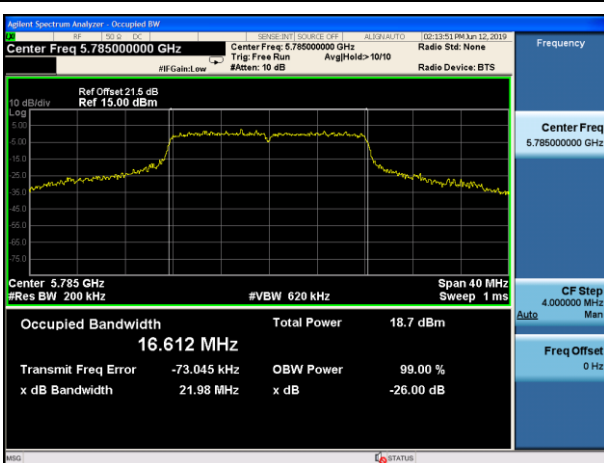

Channel 165 (5825MHz)

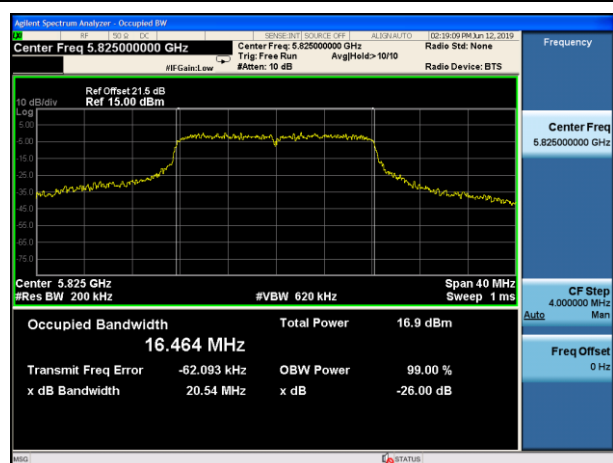

802.11n-HT20 26dB Bandwidth & 99% Bandwidth

Channel 36 (5180MHz)

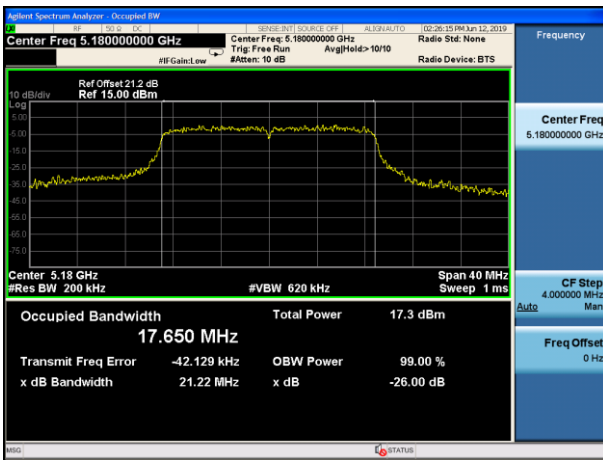

Channel 44 (5220MHz)

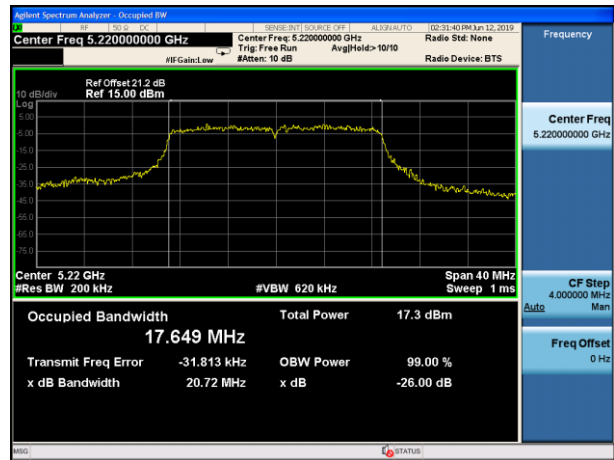

Channel 48 (5240MHz)



Channel 149 (5745MHz)

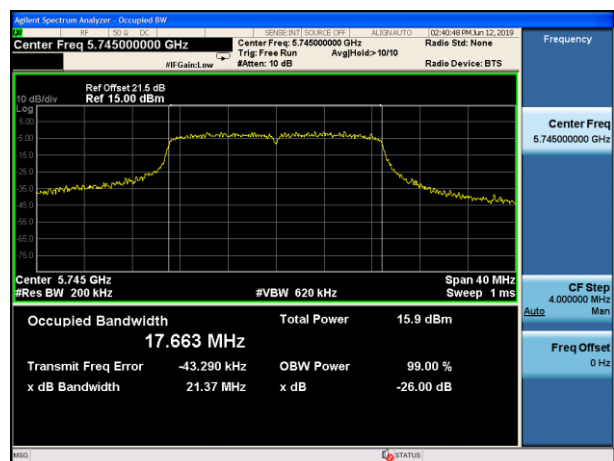

Channel 157 (5785MHz)

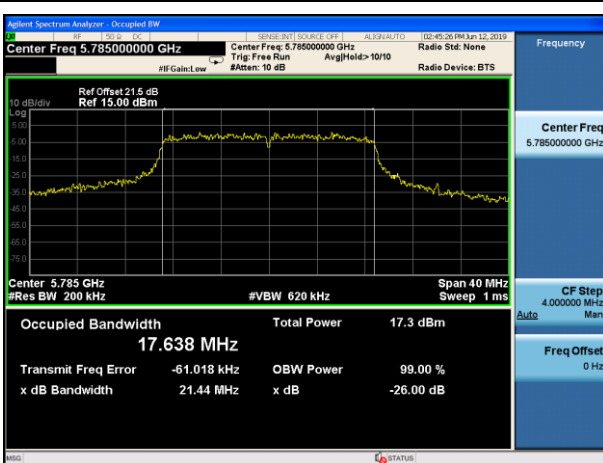

Channel 165 (5825MHz)

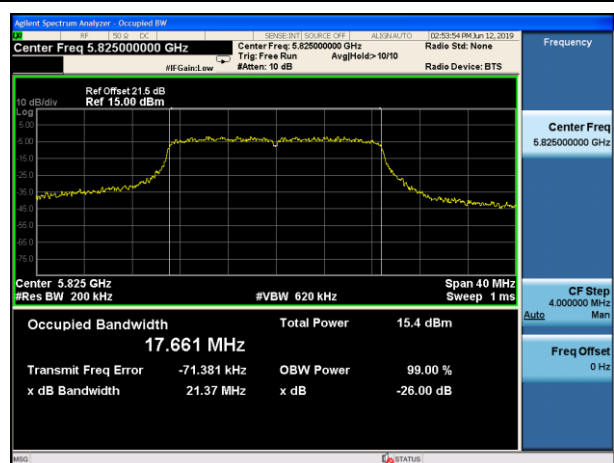

802.11n-HT40 26dB Bandwidth & 99% Bandwidth

Channel 38 (5190MHz)

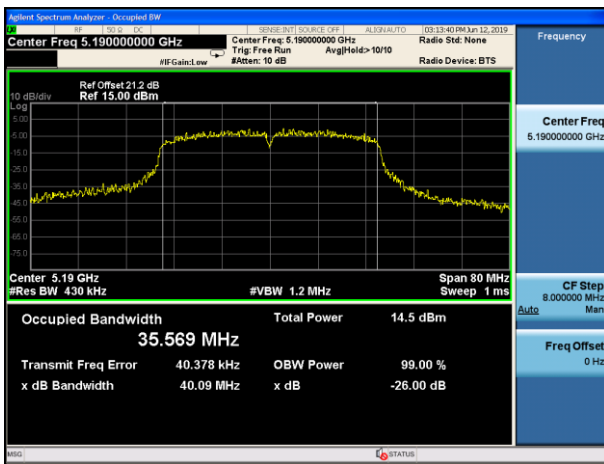

Channel 46 (5230MHz)

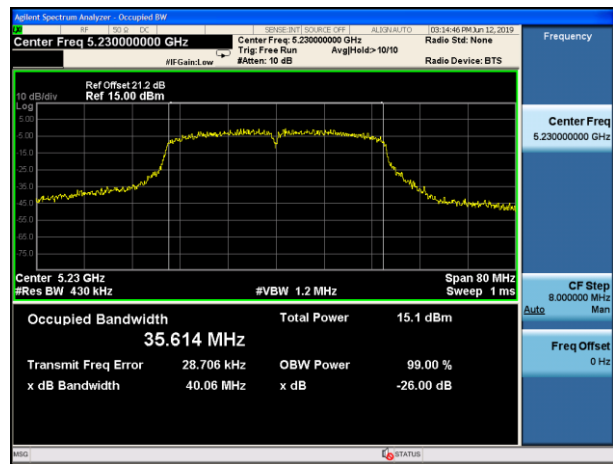

Channel 151 (5755MHz)

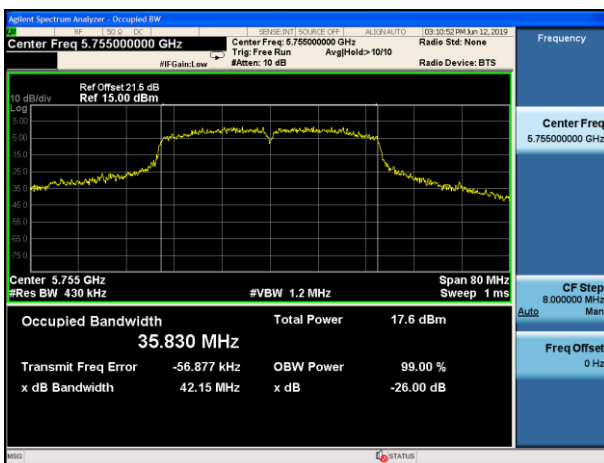

Channel 159 (5795MHz)

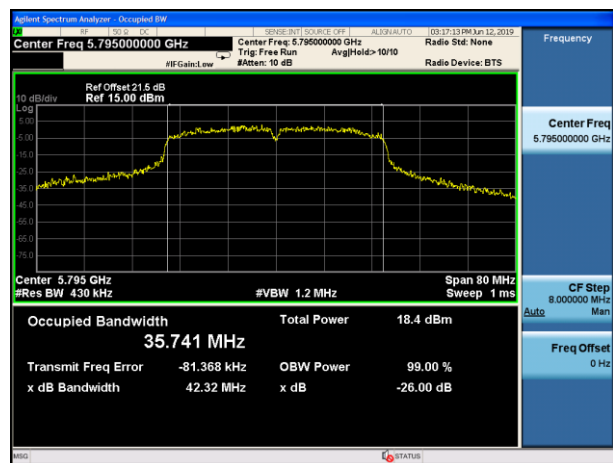

7.3. 6dB Bandwidth Measurement

7.3.1. Test Limit

The minimum 6dB bandwidth shall be at least 500 kHz.

7.3.2. Test Procedure used

KDB 789033 D02v02r01 - Section C.2

7.3.3. Test Setting

1. Set center frequency to the nominal EUT channel center frequency.
2. RBW = 100 kHz.
3. VBW $\geq 3 \times$ RBW.
4. Detector = Peak.
5. Trace mode = max hold.
6. Sweep = auto couple.
7. Allow the trace to stabilize.
8. Measure the maximum width of the emission that is constrained by the frequencies associated with the two outermost amplitude points (upper and lower frequencies) that are attenuated by 6 dB relative to the maximum level measured in the fundamental emission.

7.3.4. Test Setup

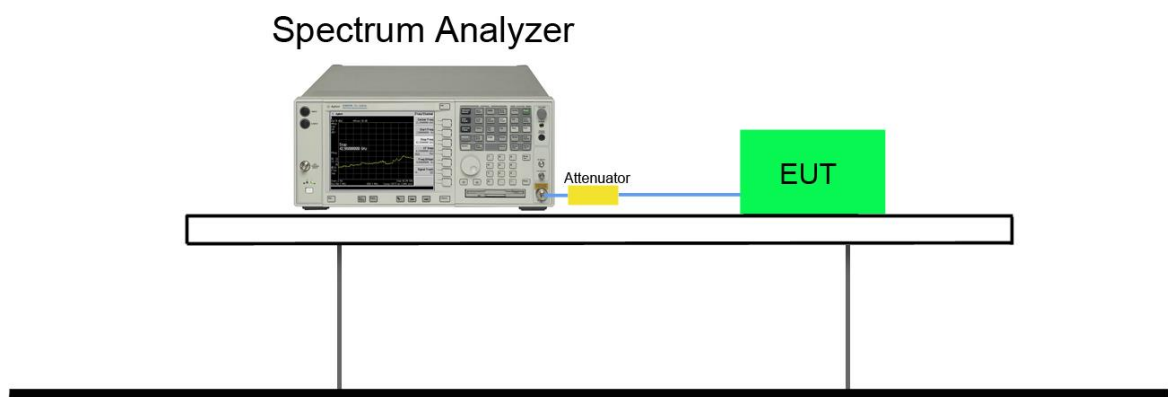

7.3.5. Test Result

Test Mode	Channel No.	Frequency (MHz)	6dB Bandwidth (MHz)	Limit (MHz)	Result
802.11a	149	5745	16.480	≥ 0.5	Pass
802.11a	157	5785	16.440	≥ 0.5	Pass
802.11a	165	5825	16.490	≥ 0.5	Pass
802.11n-HT20	149	5745	17.680	≥ 0.5	Pass
802.11n-HT20	157	5785	17.640	≥ 0.5	Pass
802.11n-HT20	165	5825	17.690	≥ 0.5	Pass
802.11n-HT40	151	5755	34.940	≥ 0.5	Pass
802.11n-HT40	159	5795	34.450	≥ 0.5	Pass

802.11a 6dB Bandwidth

Channel 149 (5745MHz)

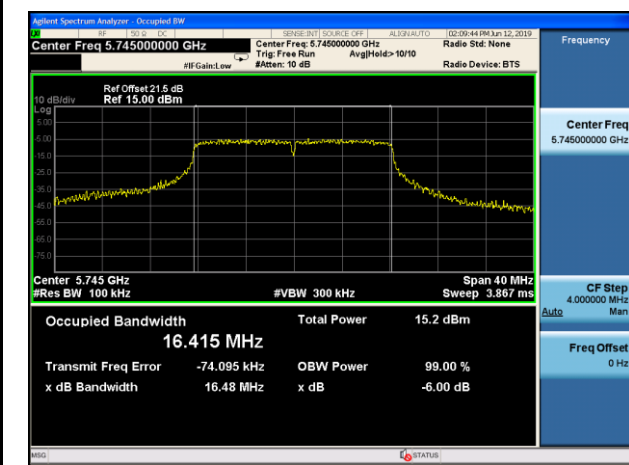

Channel 157 (5785MHz)

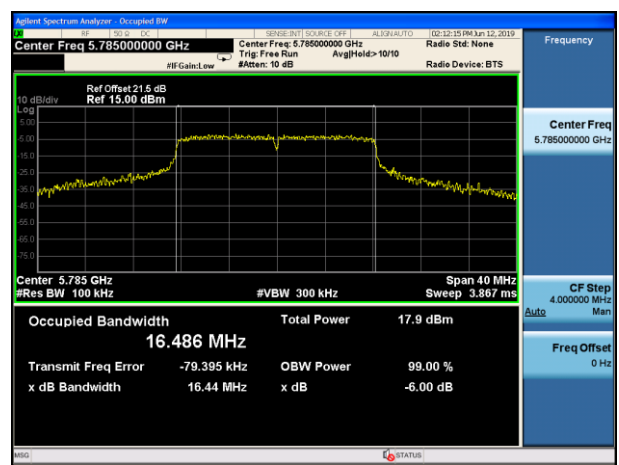

Channel 165 (5825MHz)

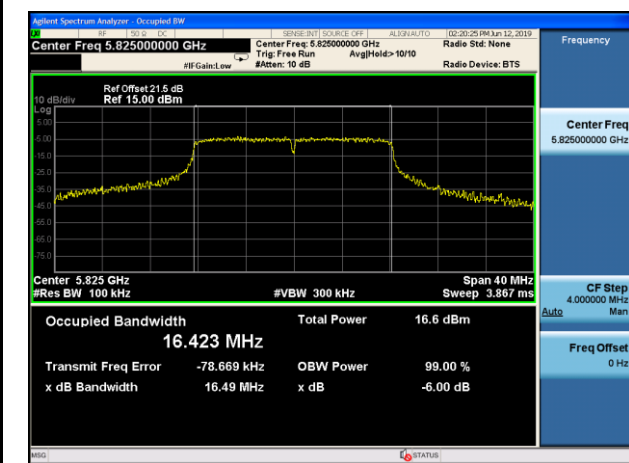

802.11n-HT20 6dB Bandwidth

Channel 149 (5745MHz)

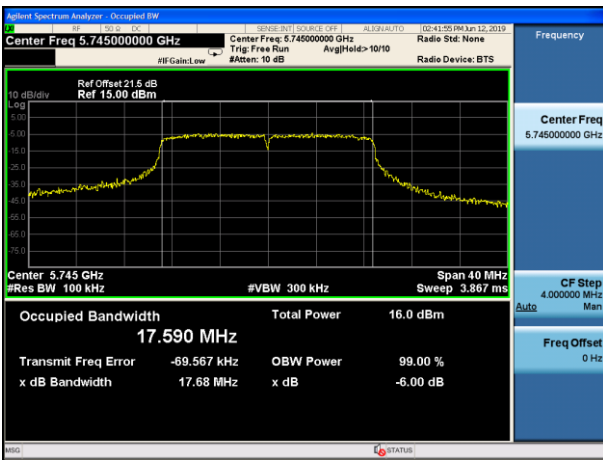

Channel 157 (5785MHz)

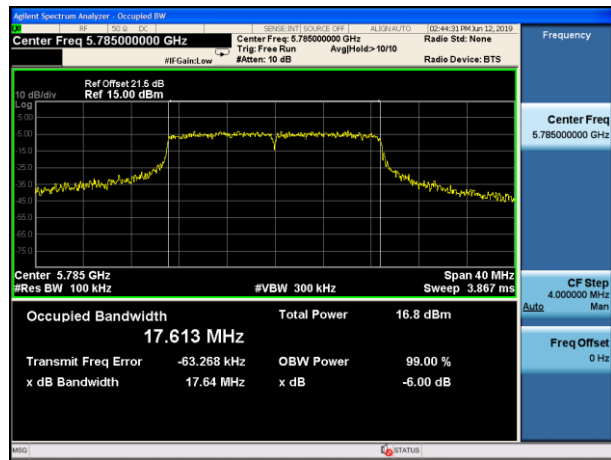

Channel 165 (5825MHz)

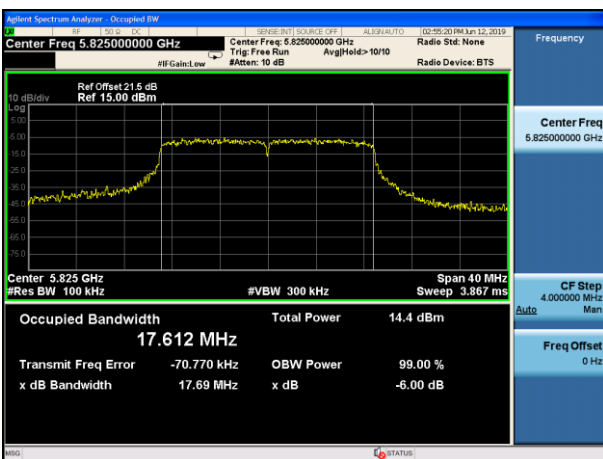

802.11n-HT40 6dB Bandwidth

Channel 151 (5755MHz)

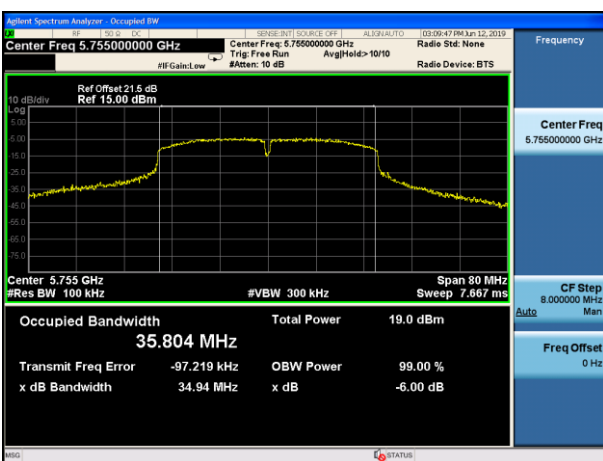

Channel 159 (5795MHz)

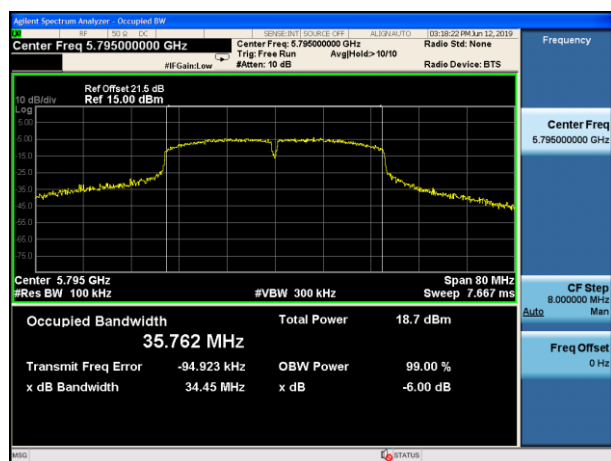

7.4. Output Power Measurement

7.4.1. Test Limit

For FCC Power Measurement Limit

For client operating in the band 5.15-5.25 GHz, the maximum conducted output power over the frequency band of operation shall not exceed 250mW.

For the 5.25-5.35 GHz and 5.47-5.725 GHz bands, the maximum conducted output power over the frequency bands of operation shall not exceed the lesser of 250 mW (23.98dBm) or $11\text{dBm} + 10 \log(26\text{dB BW})$.

For the band 5.725-5.85 GHz, the maximum conducted output power over the frequency band of operation shall not exceed 1 W (30dBm).

If transmitting antennas of directional gain greater than 6dBi are used, the maximum conducted output power shall be reduced by the amount in dB that the directional gain of the antenna exceeds 6dBi.

For IC Power Measurement Limit

For the band 5.15-5.25 GHz, the maximum e.i.r.p. shall not exceed 200 mW (23.01dBm) or $10 + 10 \cdot \log_{10} B$, dBm, whichever power is less. B is the 99% emission bandwidth in MHz.

For the 5.25-5.35 GHz and 5.47-5.725 GHz bands, the maximum conducted output power shall not exceed 250 mW (23.98dBm) or $11 + 10 \log_{10} B$, dBm, whichever power is less. The maximum e.i.r.p. shall not exceed 1.0 W (30dBm) or $17 + 10 \log_{10} B$, dBm, whichever power is less. B is the 99% emission bandwidth in MHz.

For the 5.725-5.85 GHz band, the maximum conducted output power shall not exceed 1 W.

If transmitting antennas of directional gain greater than 6dBi are used, the maximum conducted output power shall be reduced by the amount in dB that the directional gain of the antenna exceeds 6dBi.

Max Conducted Output Power Limit Calculation as below:

For U-NII-1 (5150-5250MHz)
24dBm for Client Device

For U-NII-3 (5725-5850MHz)
30dBm for Client Device

EIRP Limit Calculation as below:

For U-NII-1 (5150-5250MHz)
30dBm with 6dBi Antenna Gain

For U-NII-3 (5725-5850MHz)
36dBm with 6dBi Antenna Gain

7.4.2. Test Procedure Used

KDB 789033 D02v02r01 - Section E) 2) b) Method SA

7.4.3. Test Setting

Average power measurements were performed only when the EUT was transmitting at its maximum power control level using a broadband power meter with a pulse sensor. The power meter implemented triggering and gating capabilities which were set up such that power measurements were recorded only during the ON time of the transmitter. The trace was averaged over 100 traces to obtain the final measured average power.

7.4.4. Test Setup

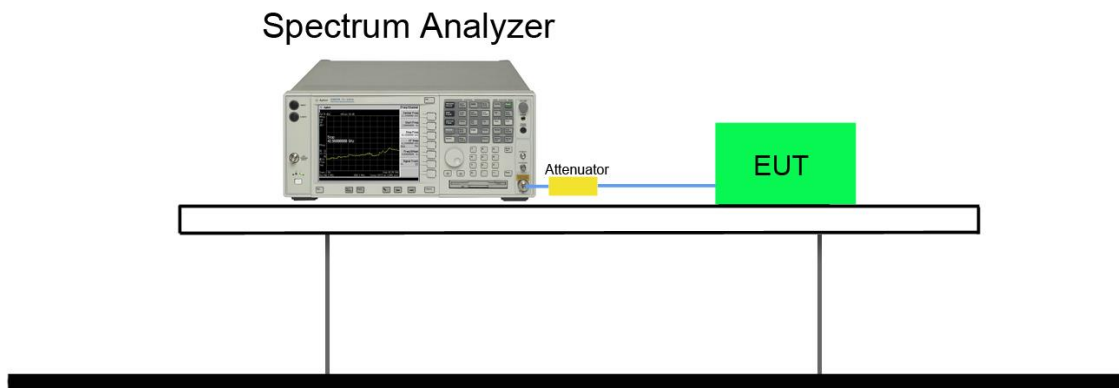

7.4.5. Test Result

RF Output Power:

5GHz 802.11a RF Output Power (dBm)										
Channel No.	Frequency (MHz)	Average Power								Required Limit (dBm)
		For different Data Rate (Mbps)								
		6	9	12	18	24	36	48	54	
36	5180	11.14	--	--	--	--	--	--	--	≤ 24
44	5220	12.71	12.70	12.63	12.61	12.55	12.43	12.40	12.35	≤ 24
48	5240	12.31	--	--	--	--	--	--	--	≤ 24
149	5745	8.85	--	--	--	--	--	--	--	≤ 30
157	5785	11.86	11.83	11.70	11.20	10.85	10.81	10.60	10.20	≤ 30
165	5825	11.33	--	--	--	--	--	--	--	≤ 30

Note: Output power = Reading value on Spectrum Analyzer + duty cycle factor + cable loss.

5GHz 802.11n-20 RF Output Power (dBm)										
Channel No.	Frequency (MHz)	Average Power								Required Limit (dBm)
		For different Data Rate (Mbps)								
		MCS0	MCS1	MCS2	MCS3	MCS4	MCS5	MCS6	MCS7	
36	5180	11.80	--	--	--	--	--	--	--	≤ 24
44	5220	11.74	11.52	11.41	11.20	10.89	10.85	10.78	10.50	≤ 24
48	5240	11.17	--	--	--	--	--	--	--	≤ 24
149	5745	9.99	--	--	--	--	--	--	--	≤ 30
157	5785	11.66	11.45	11.32	11.25	11.10	10.90	10.85	10.40	≤ 30
165	5825	13.19	--	--	--	--	--	--	--	≤ 30

Note: Output power = Reading value on Spectrum Analyzer + duty cycle factor + cable loss.

5GHz 802.11n-40 RF Output Power (dBm)										
Channel No.	Frequency (MHz)	Average Power								Required Limit (dBm)
		For different Data Rate (Mbps)								
		MCS0	MCS1	MCS2	MCS3	MCS4	MCS5	MCS6	MCS7	
38	5190	11.30	--	--	--	--	--	--	--	≤ 24
46	5230	11.63	11.52	11.31	11.00	10.85	10.71	10.63	10.52	≤ 24
151	5755	12.11	--	--	--	--	--	--	--	≤ 30
159	5795	12.39	12.35	12.30	12.10	12.03	11.98	11.95	11.60	≤ 30

Note: Output power = Reading value on Spectrum Analyzer + duty cycle factor + cable loss.

EIRP Power:

Test Mode	Channel No.	Freq. (MHz)	EIRP (dBm)	EIRP Limit (dBm)	Result
11a	36	5180	9.07	≤ 36	Pass
11a	44	5220	10.64	≤ 36	Pass
11a	48	5240	10.24	≤ 36	Pass
11a	149	5745	6.78	≤ 36	Pass
11a	157	5785	9.79	≤ 36	Pass
11a	165	5825	9.26	≤ 36	Pass
11n-HT20	36	5180	9.73	≤ 36	Pass
11n-HT20	44	5220	9.67	≤ 36	Pass
11n-HT20	48	5240	9.10	≤ 36	Pass
11n-HT20	149	5745	7.92	≤ 36	Pass
11n-HT20	157	5785	9.59	≤ 36	Pass
11n-HT20	165	5825	11.12	≤ 36	Pass
11n-HT40	38	5190	9.23	≤ 36	Pass
11n-HT40	46	5230	9.56	≤ 36	Pass
11n-HT40	151	5755	10.04	≤ 36	Pass
11n-HT40	159	5795	10.32	≤ 36	Pass

7.5. Transmit Power Control

7.5.1. Test Limit

The U-NII device is required to have the capability to operate at least 6 dB below the mean EIRP value of 30 dBm.

7.5.2. Test Procedure Used

KDB 789033 D02v02r01 - Section E) 2) b) Method SA

7.5.3. Test Setting

Average power measurements were performed only when the EUT was transmitting at its maximum power control level using a broadband power meter with a pulse sensor. The power meter implemented triggering and gating capabilities which were set up such that power measurements were recorded only during the ON time of the transmitter. The trace was averaged over 100 traces to obtain the final measured average power.

7.5.4. Test Setup

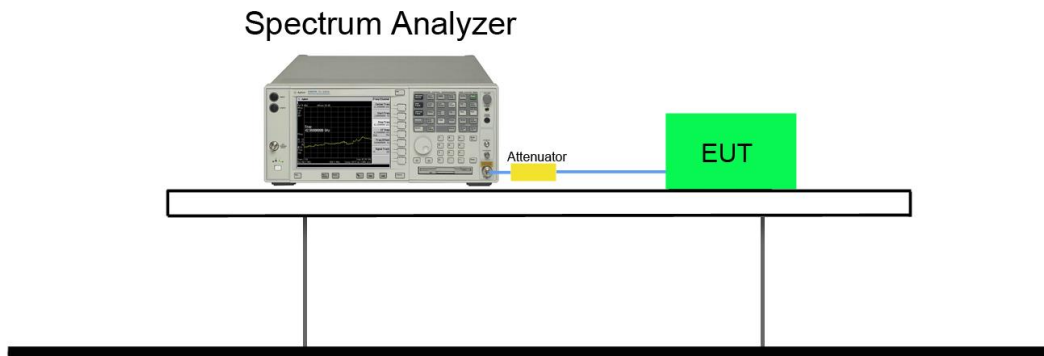

7.5.5. Test Result

Note TPC mechanism is not required for systems with an e.i.r.p. of less than 500 mW.

7.6. Power Spectral Density Measurement

7.6.1. Test Limit

For FCC Power Spectral Density Limit

For an outdoor access point operating in the band 5.15-5.25 GHz, the maximum power spectral density shall not exceed 17 dBm in any 1 megahertz band.

For the 5.25-5.35 GHz and 5.47-5.725 GHz bands, the maximum power spectral density shall not exceed 11 dBm in any 1 megahertz band.

For the band 5.725-5.85 GHz, the maximum power spectral density shall not exceed 30 dBm in any 500-kHz band.

If transmitting antennas of directional gain greater than 6dBi are used, the peak power spectral density shall be reduced by the amount in dB that the directional gain of the antenna exceeds 6dBi.

For IC Power Spectral Density Limit

For the band 5.15-5.25 GHz, the e.i.r.p. spectral density shall not exceed 10 dBm in any 1.0 MHz band.

For the 5.25-5.35 GHz and 5.47-5.725 GHz bands, the power spectral density shall not exceed 11 dBm in any 1.0 MHz band.

For the 5.725-5.85 GHz band, the power spectral density shall not exceed 30 dBm in any 500 kHz band.

7.6.2. Test Procedure Used

KDB 789033 D02v02r01 - Section F

7.6.3. Test Setting

1. Analyzer was set to the center frequency of the UNII channel under investigation
2. Span was set to encompass the entire 26dB EBW of the signal.
3. RBW = 1MHz, if measurement bandwidth of Maximum PSD is specified in 500 kHz,
4. RBW = 100 kHz
5. VBW = 3MHz
6. Number of sweep points $\geq 2 \times (\text{span} / \text{RBW})$
7. Detector = power averaging (Average)
8. Sweep time = auto
9. Trigger = free run
10. Use the peak search function on the instrument to find the peak of the spectrum and record its value.
11. Add $10 \cdot \log(1/x)$, where x is the duty cycle, to the measured power in order to compute the average power during the actual transmission times (because the measurement represents an average over both the on and off times of the transmission). For example, add $10 \cdot \log(1/0.25) = 6$ dB if the duty cycle is 25 percent.
12. When the measurement bandwidth of Maximum PSD is specified in 500 kHz, add a constant factor $10 \cdot \log(500\text{kHz}/100\text{kHz}) = 7$ dB to the measured result

7.6.4. Test Setup

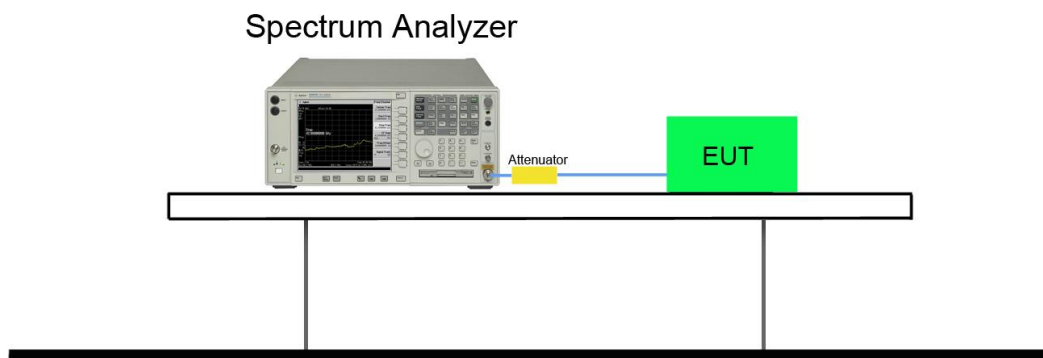

7.6.5. Test Result

For FCC bands (UNII-1)

Test Mode	Data Rate (Mbps)	Channel No.	Freq. (MHz)	PSD (dBm/MHz)	Duty Cycle (%)	Total PSD (dBm/MHz)	PSD Limit (dBm/MHz)	Result
11a	6	36	5180	1.153	100%	-0.917	≤ 11	Pass
11a	6	44	5220	3.375	100%	1.305	≤ 11	Pass
11a	6	48	5240	2.984	100%	0.914	≤ 11	Pass
11n-HT20	6.5	36	5180	1.821	100%	-0.249	≤ 11	Pass
11n-HT20	6.5	44	5220	1.443	100%	-0.627	≤ 11	Pass
11n-HT20	6.5	48	5240	0.796	100%	-1.274	≤ 11	Pass
11n-HT40	13.5	38	5190	-1.089	100%	-3.159	≤ 11	Pass
11n-HT40	13.5	46	5230	-1.148	100%	-3.218	≤ 11	Pass

For FCC bands (UNII-4)

Test Mode	Data Rate (Mbps)	Channel No.	Freq. (MHz)	PSD (dBm/100kHz)	Duty Cycle (%)	Constant Factor	Total PSD (dBm/500kHz)	Limit (dBm/500kHz)	Result
11a	6	149	5745	-3.639	100%	-3.639	-5.709	≤ 30	Pass
11a	6	157	5785	-0.247	100%	-0.247	-2.317	≤ 30	Pass
11a	6	165	5825	-1.603	100%	-1.603	-3.673	≤ 30	Pass
11n-HT20	6.5	149	5745	-3.194	100%	-3.194	-5.264	≤ 30	Pass
11n-HT20	6.5	157	5785	-1.199	100%	-1.199	-3.269	≤ 30	Pass
11n-HT20	6.5	165	5825	-0.194	100%	-0.194	-2.264	≤ 30	Pass
11n-HT40	13.5	151	5755	-3.573	100%	-3.573	-5.643	≤ 30	Pass
11n-HT40	13.5	159	5795	-3.200	100%	-3.200	-5.270	≤ 30	Pass

802.11a Power Spectral Density

Channel 36 (5180MHz)

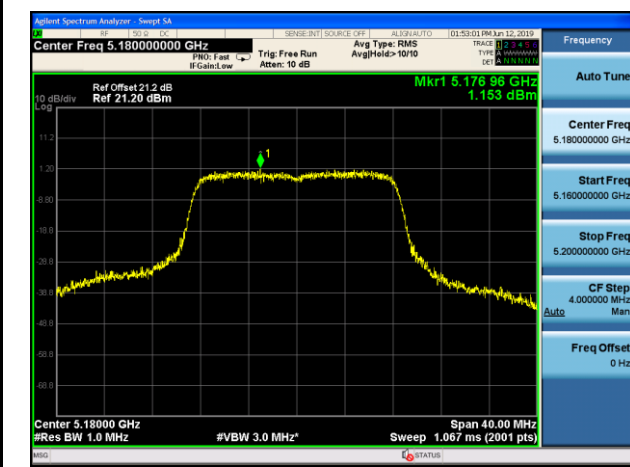

Channel 44 (5220MHz)

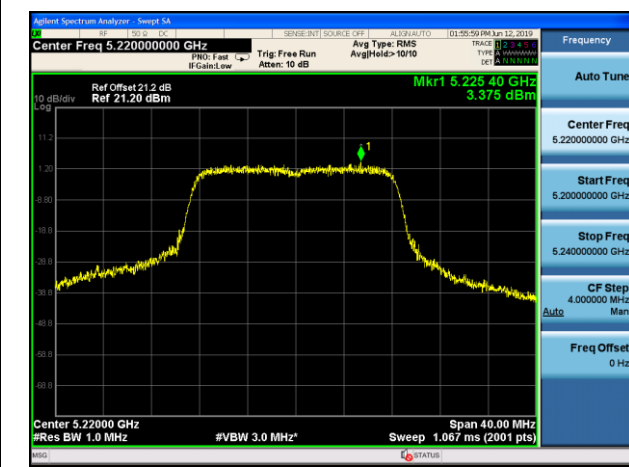

Channel 48 (5240MHz)

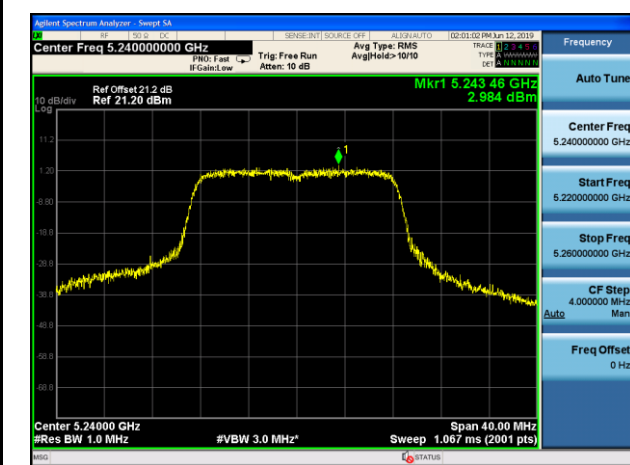

Channel 149 (5745MHz)

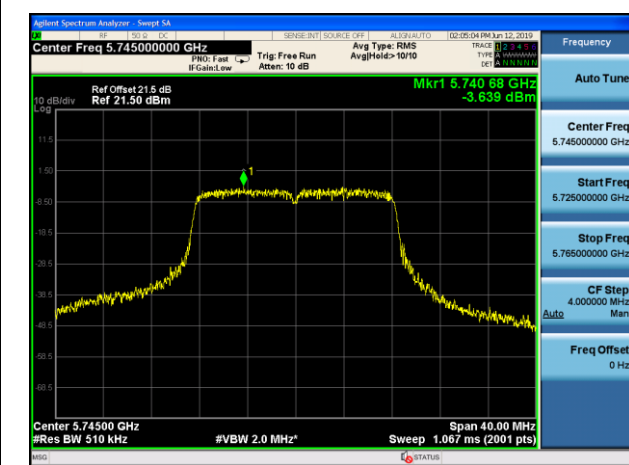

Channel 157 (5785MHz)

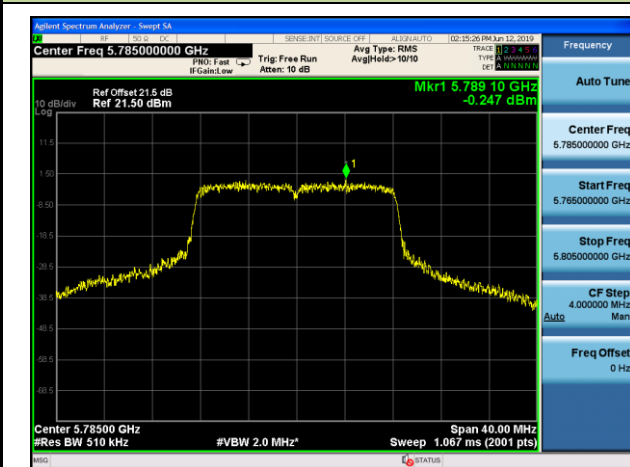

Channel 165 (5825MHz)

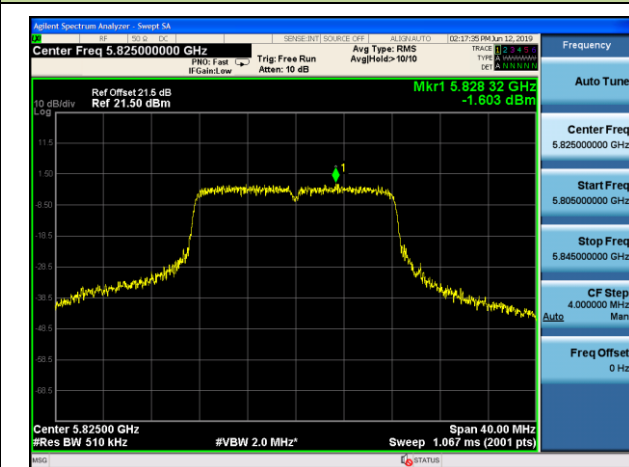

802.11n-HT20 Power Spectral Density

Channel 36 (5180MHz)

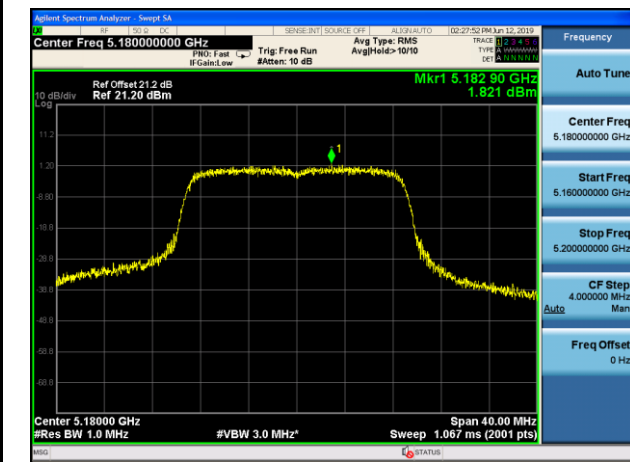

Channel 44 (5220MHz)

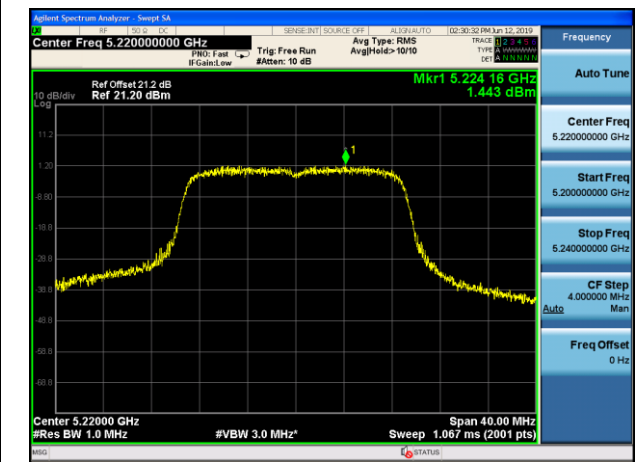

Channel 48 (5240MHz)

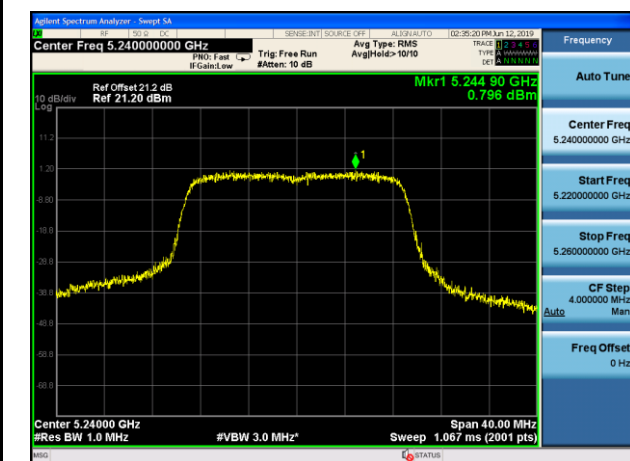

Channel 149 (5745MHz)

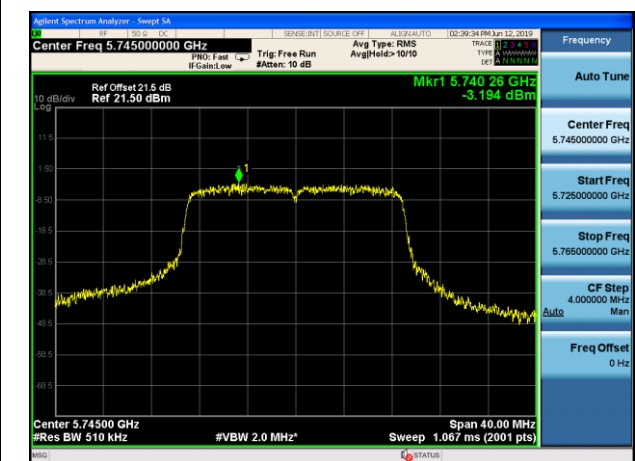

Channel 157 (5785MHz)

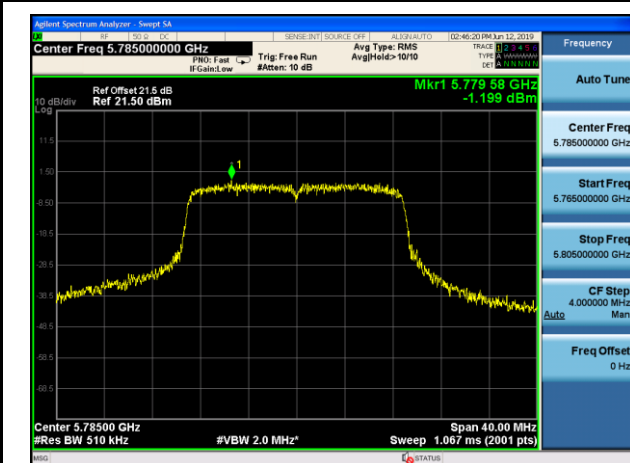

Channel 165 (5825MHz)

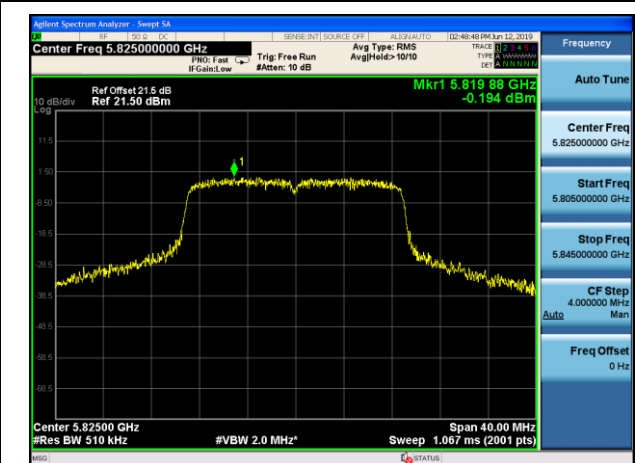

802.11n-HT40 Power Spectral Density

Channel 38 (5190MHz)

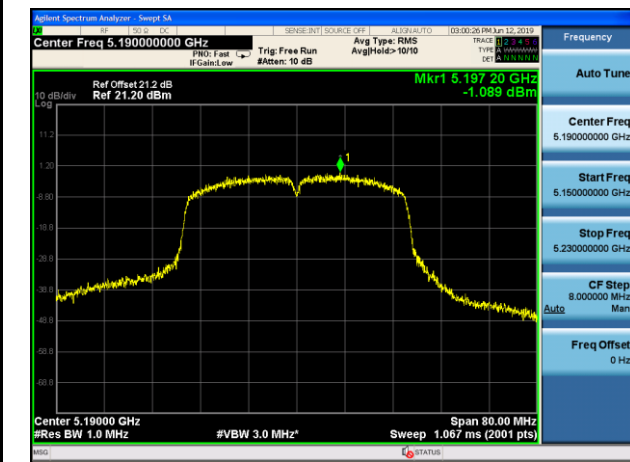

Channel 46 (5230MHz)

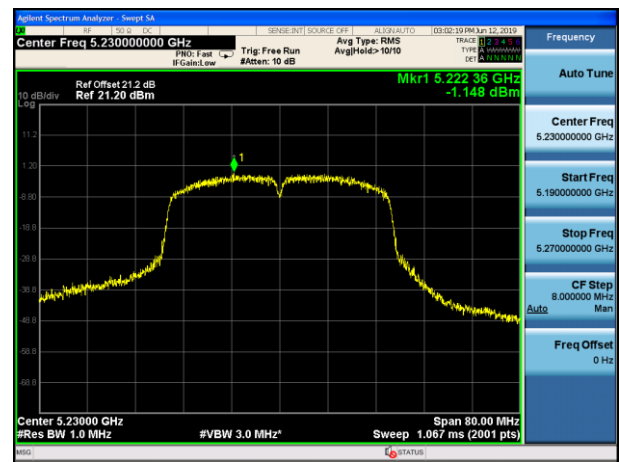

Channel 151 (5755MHz)

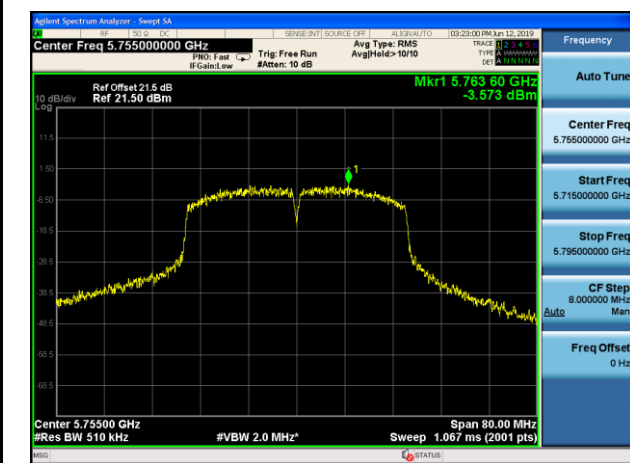

Channel 159 (5795MHz)

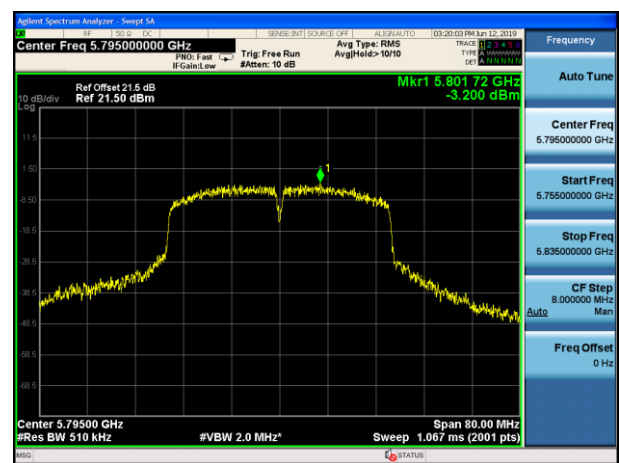

7.7. Radiated Spurious Emission Measurement

7.7.1. Test Limit

All out of band emissions appearing in a restricted band as specified in Section 15.205 of the Title 47 CFR must not exceed the limits shown in Table per Section 15.209.

FCC Part 15 Subpart C Paragraph 15.209		
Frequency [MHz]	Field Strength [V/m]	Measured Distance [Meters]
0.009 – 0.490	2400/F (kHz)	300
0.490 – 1.705	24000/F (kHz)	30
1.705 - 30	30	30
30 - 88	100	3
88 - 216	150	3
216 - 960	200	3
Above 960	500	3

7.7.2. Test Procedure Used

KDB 789033 D02v02r01 – Section G

7.7.3. Test Setting

Peak Measurements above 1GHz

1. Analyzer center frequency was set to the frequency of the radiated spurious emission of interest
2. RBW = 1MHz
3. VBW = 3MHz
4. Detector = peak
5. Sweep time = auto couple
6. Trace mode = max hold
7. Trace was allowed to stabilize

Quasi-Peak Measurements below 1GHz

1. Analyzer center frequency was set to the frequency of the radiated spurious emission of interest
2. Span was set greater than 1MHz
3. RBW = 120 kHz
4. Detector = CISPR quasi-peak
5. Sweep time = auto couple
6. Trace was allowed to stabilize

Average Measurements above 1GHz (Method AD)

1. Analyzer center frequency was set to the frequency of the radiated spurious emission of interest
2. RBW = 1MHz
3. VBW = 3MHz
4. Detector = power average (Average)
5. Number of measurement points = 1001 (Number of points must be $> 2 \times \text{span/RBW}$)
6. Sweep time = auto
7. Trace was averaged over at 100 sweeps

Quasi-Peak & Average Measurements below 30MHz

1. Analyzer center frequency was set to the frequency of the radiated spurious emission of interest
2. Span was set greater than 1MHz
3. RBW = 200Hz for 9kHz to 150kHz frequency; RBW = 9kHz for 0.15MHz to 30MHz frequency
4. Detector = CISPR quasi-peak or power average (Average)
5. Sweep time = auto couple
6. Trace was allowed to stabilize

7.7.4. Test Setup

9kHz ~ 30MHz Test Setup:

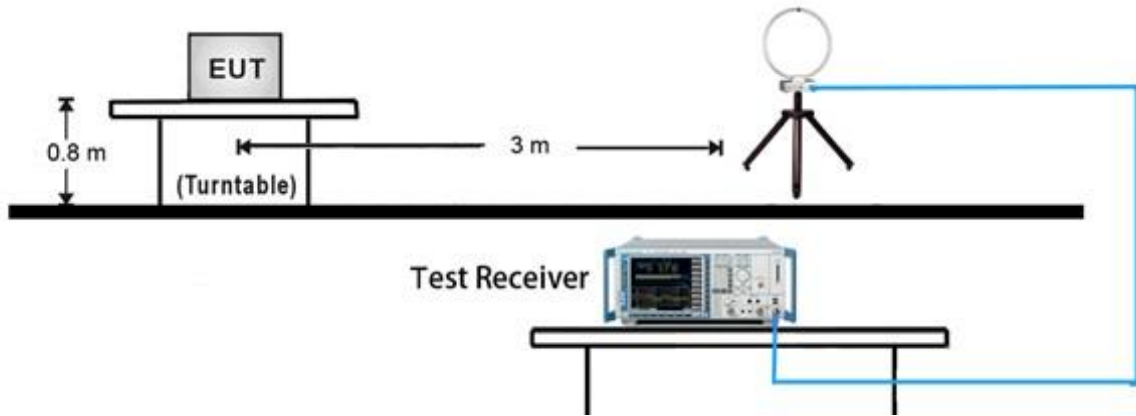

30MHz ~ 1GHz Test Setup:

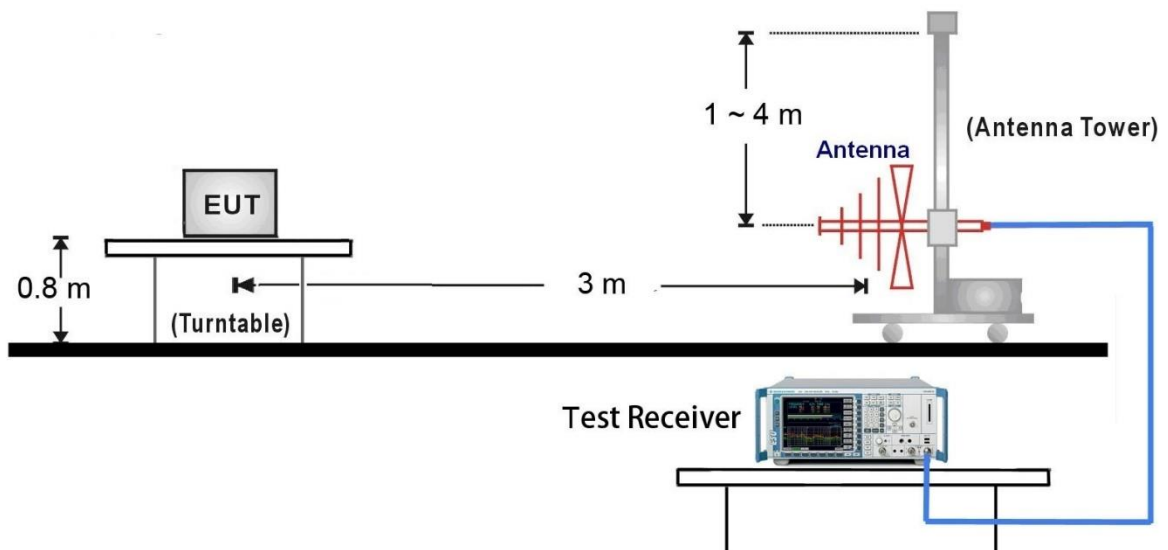

1GHz ~18GHz Test Setup:

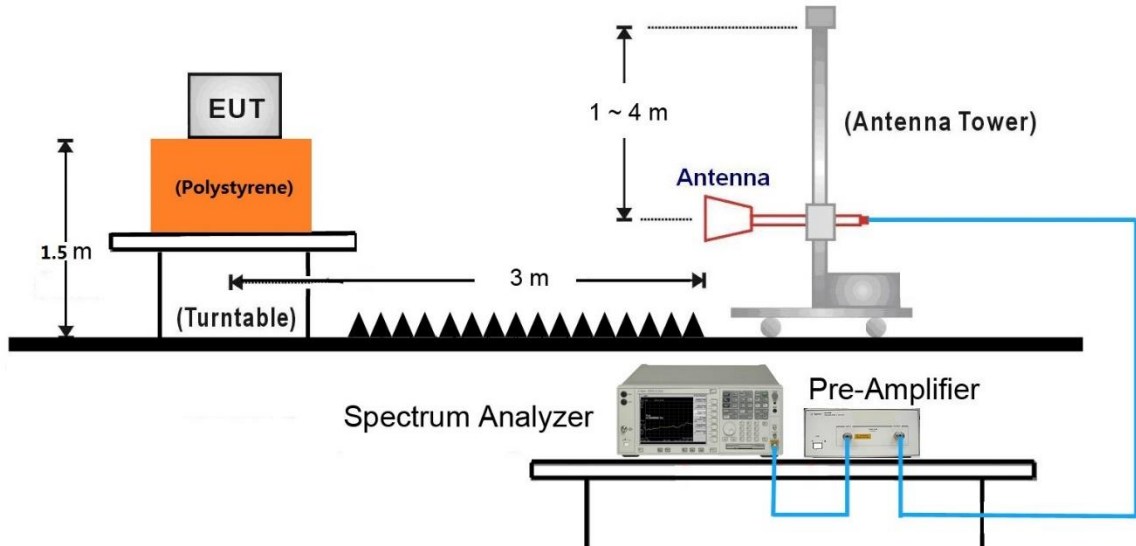

18GHz ~40GHz Test Setup:

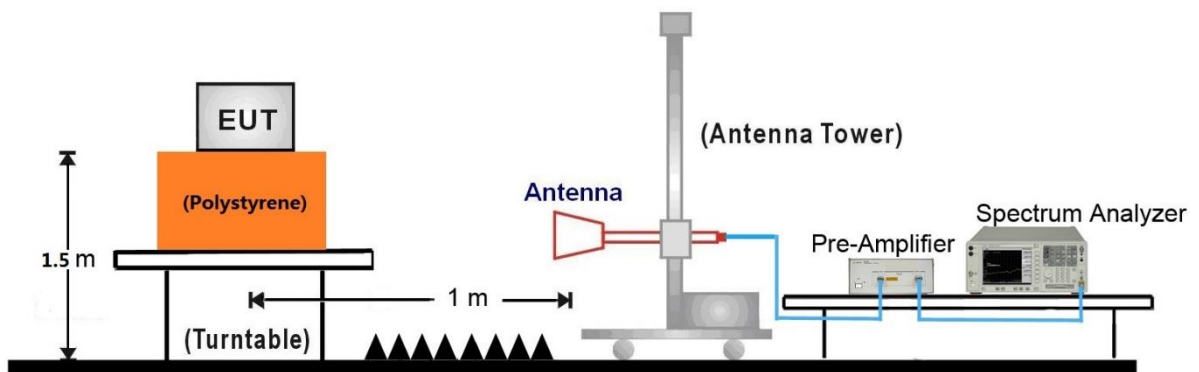

7.7.5. Test Result

EUT	Wireless module	Test Date	2019/4/15
Factor	VULB 9162	Temp. / Humidity	25°C / 60%
Polarity	Horizontal	Site / Engineer	AC1 / Peter
Test Mode	MODE2_CH44	Test Voltage	AC 120V/60Hz

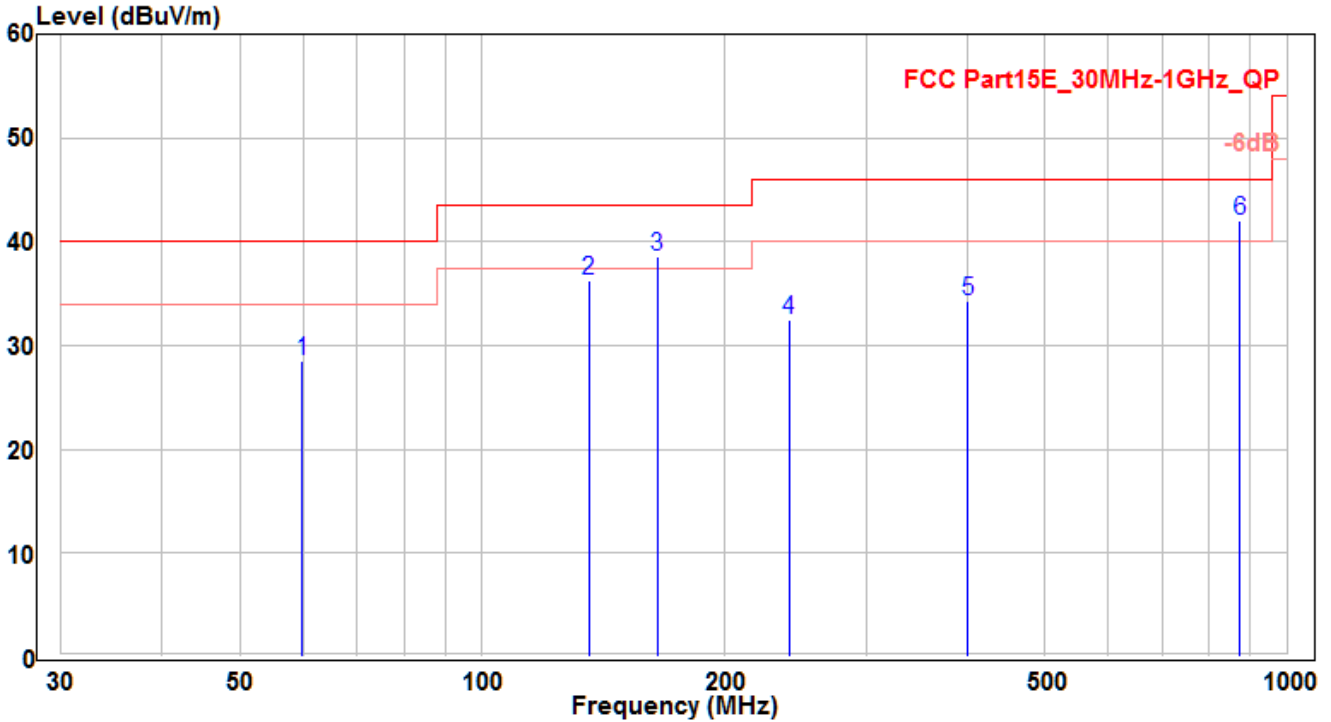

No	Frequency (MHz)	Reading (dBuV)	C.F (dB)	Measurement (dBuV/m)	Margin (dB)	Limit (dBuV)	Height (cm)	Angle (deg)	Remark (QP/PK/AV)
1	59.767	8.34	20.15	28.49	-11.51	40	125	100	QP
2	135.63	20.27	15.96	36.23	-7.27	43.5	150	140	QP
3	165.123	22.21	16.29	38.5	-5	43.5	185	175	QP
4	240.456	12.49	19.92	32.41	-13.59	46	190	360	QP
5	401.3	10.31	23.97	34.28	-11.72	46	125	190	QP
6	* 874.99	10.67	31.33	42	-4	46	155	140	QP

Note: The EUT Power by Notebook PC

- "*" means the worst value in this measurement data.
- Measure Level (dBuV/m) = Reading Level (dBuV) + Factor (dB)
- C.F Factor (dB) = Cable Loss (dB) + Antenna Factor (dB/m).
- The emission levels of other frequencies are very lower than the limit and not show in test report.
- Other channel/mode was also verified. The test results shown represent the worst case emissions.
- No emission found between lowest internal used/generated frequency to 30MHz.

EUT	Wireless module	Test Date	2019/4/15
Factor	VULB 9162	Temp. / Humidity	25°C / 60%
Polarity	Vertical	Site / Engineer	AC1 / Peter
Test Mode	MODE2_CH44	Test Voltage	AC 120V/60Hz

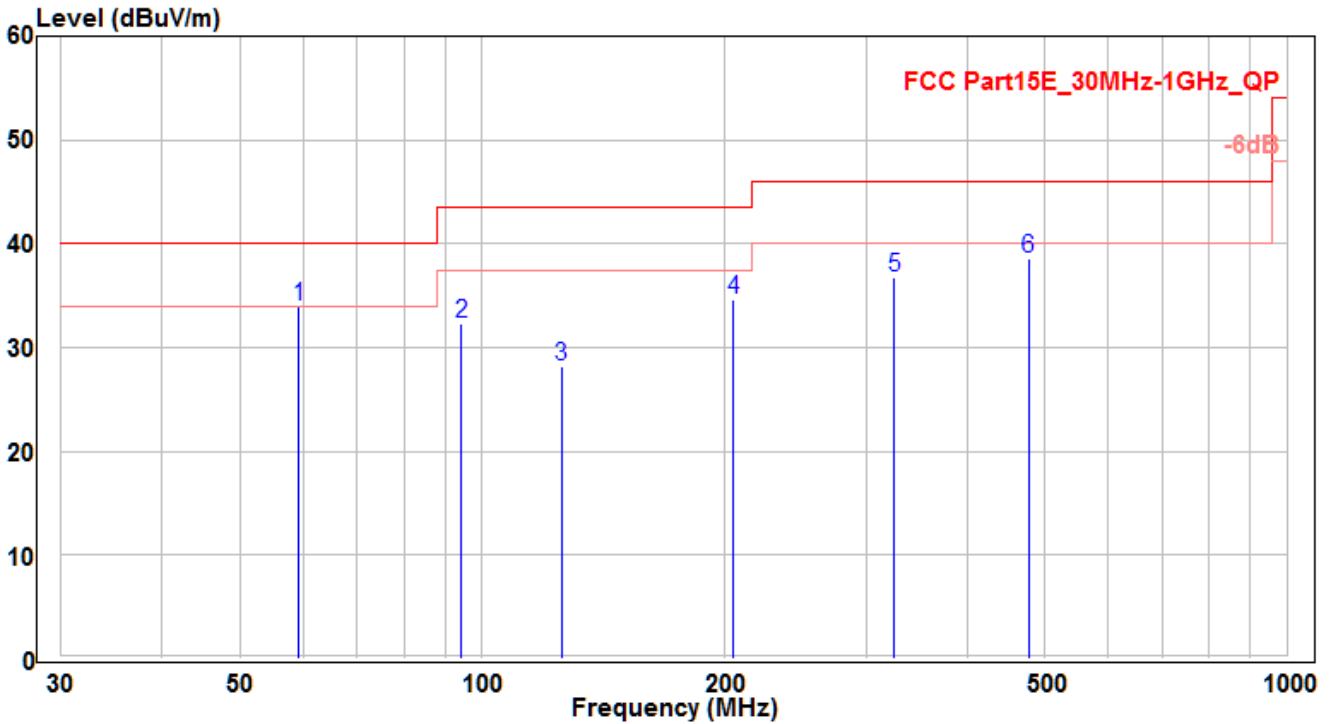

No	Frequency (MHz)	Reading (dBuV)	C.F (dB)	Measurement (dBuV/m)	Margin (dB)	Limit (dBuV)	Height (cm)	Angle (deg)	Remark (QP/PK/AV)	
1	*	59.13	13.76	20.26	34.02	-5.98	40	115	240	QP
2		94.172	14.42	17.91	32.33	-11.17	43.5	190	360	QP
3		125.636	11.11	17.07	28.18	-15.32	43.5	155	-40	QP
4		205.267	15.6	19.01	34.61	-8.89	43.5	185	170	QP
5		325.062	14.35	22.37	36.72	-9.28	46	100	0	QP
6		477.746	13.31	25.34	38.65	-7.35	46	165	230	QP

Note: The EUT Power by Notebook PC

1. " * " means the worst value in this measurement data.
2. Measure Level (dBuV/m) = Reading Level (dBuV) + Factor (dB)
3. C.F Factor (dB) = Cable Loss (dB) + Antenna Factor (dB/m).
4. The emission levels of other frequencies are very lower than the limit and not show in test report.
5. Other channel/mode was also verified. The test results shown represent the worst case emissions.
6. No emission found between lowest internal used/generated frequency to 30MHz.

EUT	Wireless module	Test Date	2019/6/12
Factor	BBHA 9120D & BBHA 9170	Temp. / Humidity	25°C / 60%
Polarity	Horizontal	Site / Engineer	AC1 / Peter
Test Mode	MODE1 -CH36	Test Voltage	AC 120V/60Hz

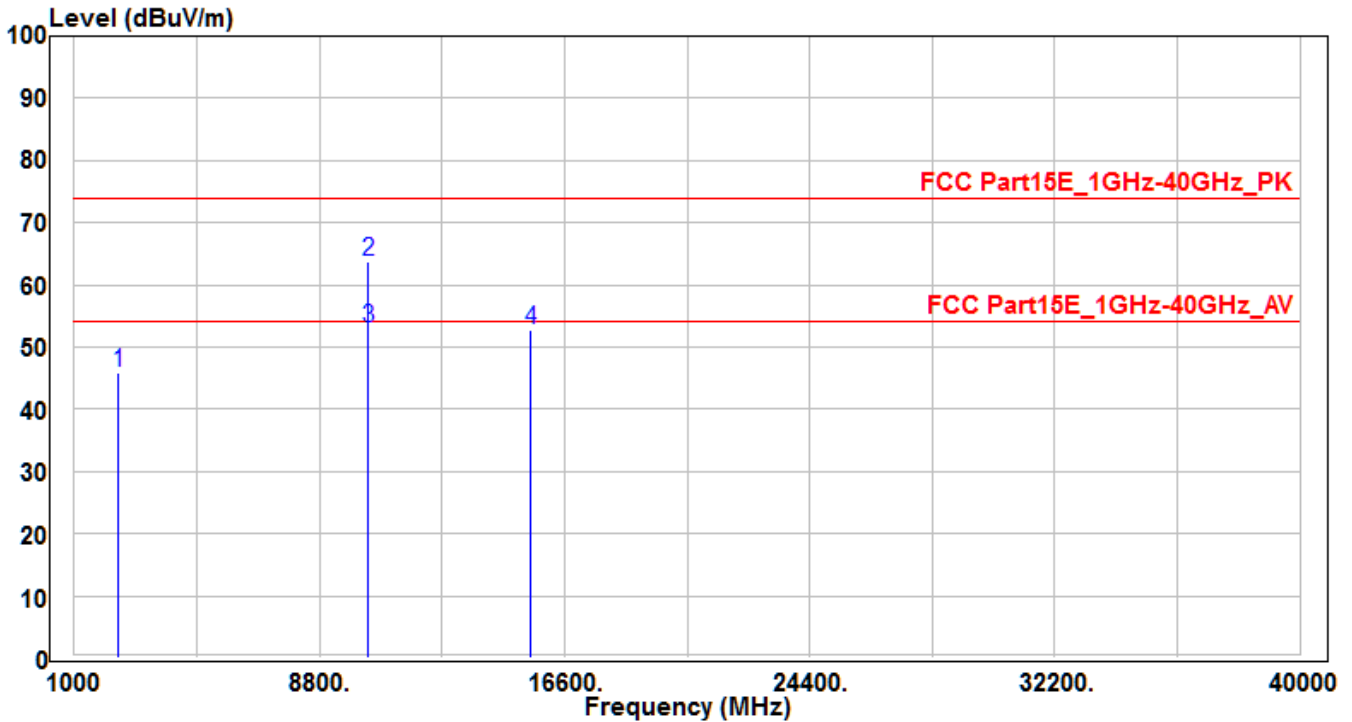

No	Frequency (MHz)	Reading (dBuV)	C.F (dB)	Measurement (dBuV/m)	Margin (dB)	Limit (dBuV)	Height (cm)	Angle (deg)	Remark (QP/PK/AV)	
1	2394.36	48.53	-2.59	45.94	-28.06	74	150	400	Peak	
2	*	10360	46.96	16.74	63.7	-10.3	74	150	140	Peak
3	*	10360	36.41	16.74	53.15	-0.85	54	150	140	Average
4		15540	31.1	21.69	52.79	-21.21	74	150	400	Peak

Note: The EUT Power by Notebook PC

1. " * " means the worst value in this measurement data.
2. Measure Level (dBuV/m) = Reading Level (dBuV) + Factor (dB)
3. C.F Factor (dB) = Cable Loss (dB) + Antenna Factor (dB/m) - Preamplifier(dB).
4. The emission levels of other frequencies are very lower than the limit and not show in test report.

EUT	Wireless module	Test Date	2019/6/12
Factor	BBHA 9120D & BBHA 9170	Temp. / Humidity	25°C / 60%
Polarity	Vertical	Site / Engineer	AC1 / Peter
Test Mode	MODE1 -CH36	Test Voltage	AC 120V/60Hz

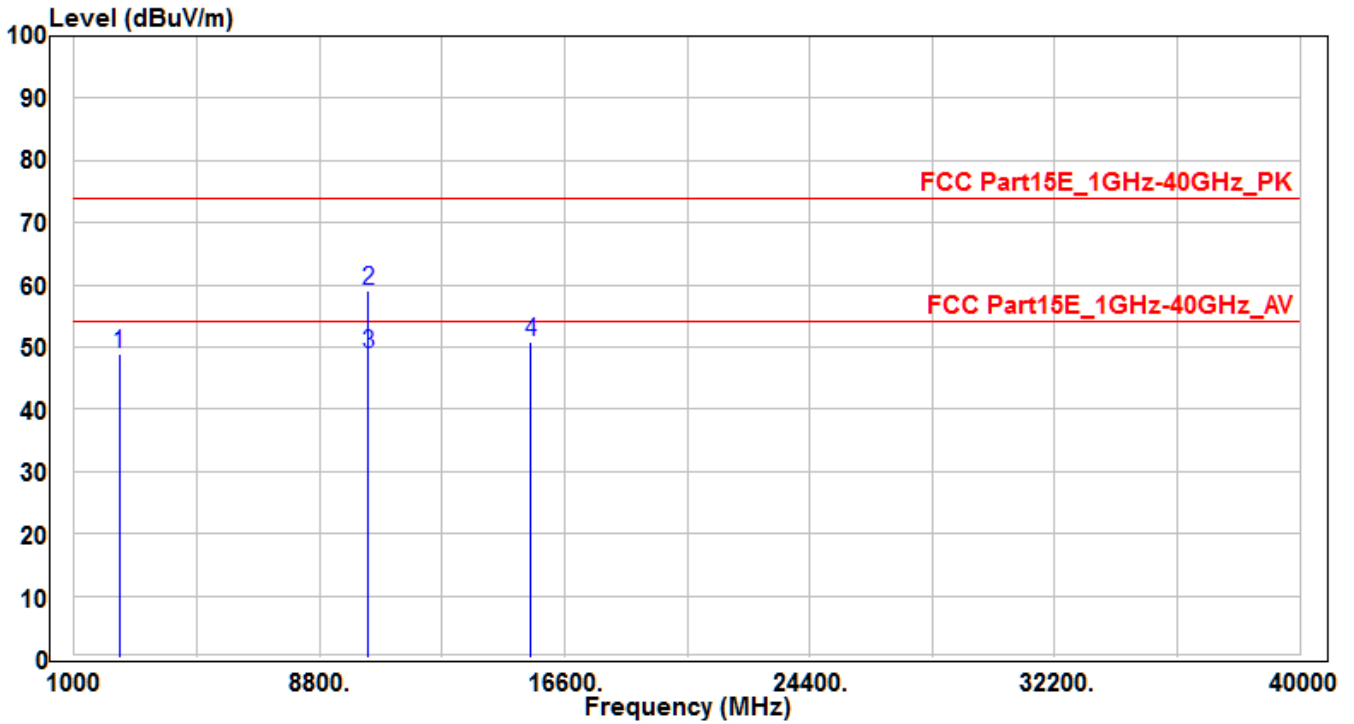

No	Frequency (MHz)	Reading (dBuV)	C.F (dB)	Measurement (dBuV/m)	Margin (dB)	Limit (dBuV)	Height (cm)	Angle (deg)	Remark (QP/PK/AV)
1	2426.28	51.35	-2.45	48.9	-25.1	74	150	400	Peak
2	* 10360	42.37	16.74	59.11	-14.89	74	150	190	Peak
3	* 10360	32.16	16.74	48.9	-5.1	54	150	190	Average
4	15540	29.2	21.69	50.89	-23.11	74	150	400	Peak

Note: The EUT Power by Notebook PC

- "*" means the worst value in this measurement data.
- Measure Level (dBuV/m) = Reading Level (dBuV) + Factor (dB)
- C.F Factor (dB) = Cable Loss (dB) + Antenna Factor (dB/m) - Pre-amplifier (dB).
- The emission levels of other frequencies are very lower than the limit and not show in test report.

EUT	Wireless module	Test Date	2019/6/12
Factor	BBHA 9120D & BBHA 9170	Temp. / Humidity	25°C / 60%
Polarity	Horizontal	Site / Engineer	AC1 / Peter
Test Mode	MODE1 -CH44	Test Voltage	AC 120V/60Hz

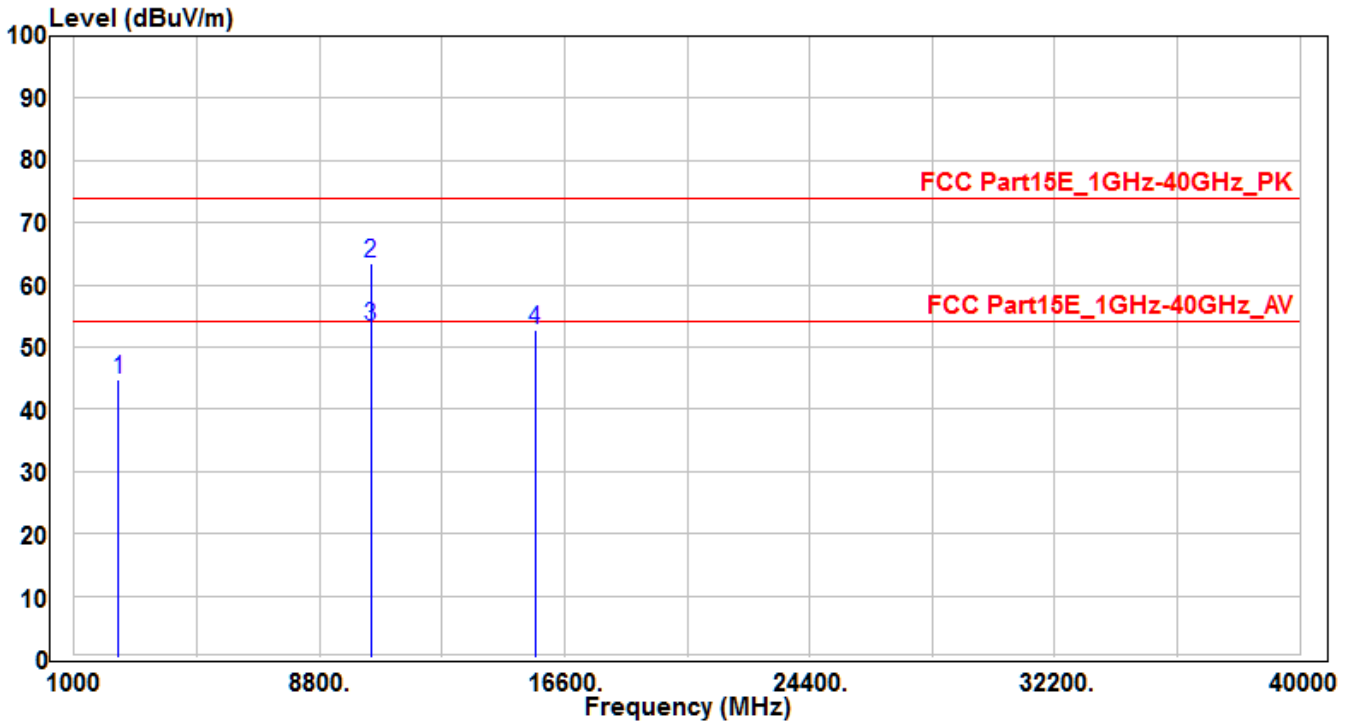

No	Frequency (MHz)	Reading (dBuV)	C.F (dB)	Measurement (dBuV/m)	Margin (dB)	Limit (dBuV)	Height (cm)	Angle (deg)	Remark (QP/PK/AV)	
1	2398.36	47.25	-2.57	44.68	-29.32	74	150	400	Peak	
2	*	10440	46.47	16.99	63.46	-10.54	74	150	140	Peak
3	*	10440	36.2	16.99	53.19	-0.81	54	150	140	Average
4		15660	31.34	21.48	52.82	-21.18	74	150	400	Peak

Note: The EUT Power by Notebook PC

- "*" means the worst value in this measurement data.
- Measure Level (dBuV/m) = Reading Level (dBuV) + Factor (dB)
- C.F Factor (dB) = Cable Loss (dB) + Antenna Factor (dB/m) - Pre-amplifier (dB).
- The emission levels of other frequencies are very lower than the limit and not show in test report.

EUT	Wireless module	Test Date	2019/6/12
Factor	BBHA 9120D & BBHA 9170	Temp. / Humidity	25°C / 60%
Polarity	Vertical	Site / Engineer	AC1 / Peter
Test Mode	MODE1 -CH44	Test Voltage	AC 120V/60Hz

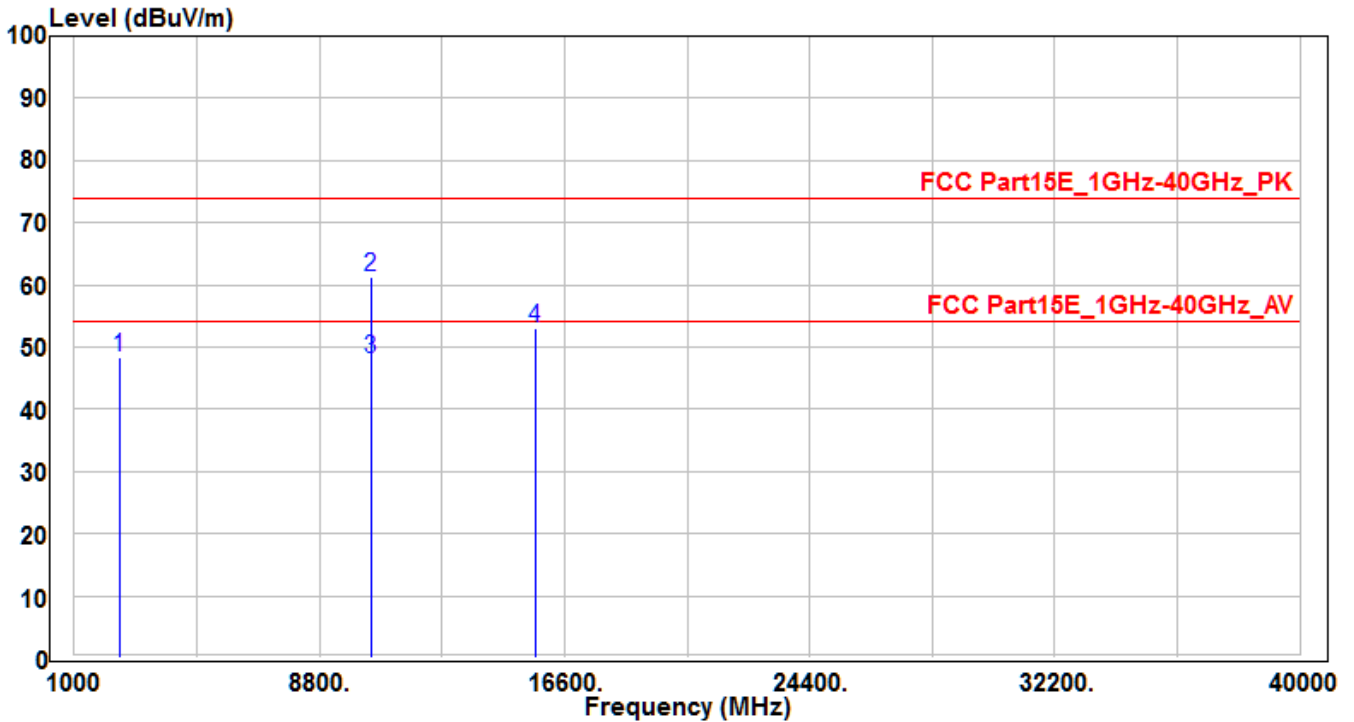

No	Frequency (MHz)	Reading (dBuV)	C.F (dB)	Measurement (dBuV/m)	Margin (dB)	Limit (dBuV)	Height (cm)	Angle (deg)	Remark (QP/PK/AV)	
1	2423.55	50.75	-2.45	48.3	-25.7	74	150	400	Peak	
2	*	10440	44.15	16.99	61.14	-12.86	74	150	190	Peak
3	*	10440	31.2	16.99	48.19	-5.81	54	150	190	Average
4		15660	31.63	21.48	53.11	-20.89	74	150	400	Peak

Note: The EUT Power by Notebook PC

1. " * " means the worst value in this measurement data.
2. Measure Level (dB μ V/m) = Reading Level (dB μ V) + Factor (dB)
3. C.F Factor (dB) = Cable Loss (dB) + Antenna Factor (dB/m) - Pre-amplifier(dB).
4. The emission levels of other frequencies are very lower than the limit and not show in test report.

EUT	Wireless module	Test Date	2019/6/12
Factor	BBHA 9120D & BBHA 9170	Temp. / Humidity	25°C / 60%
Polarity	Horizontal	Site / Engineer	AC1 / Peter
Test Mode	MODE1 -CH48	Test Voltage	AC 120V/60Hz

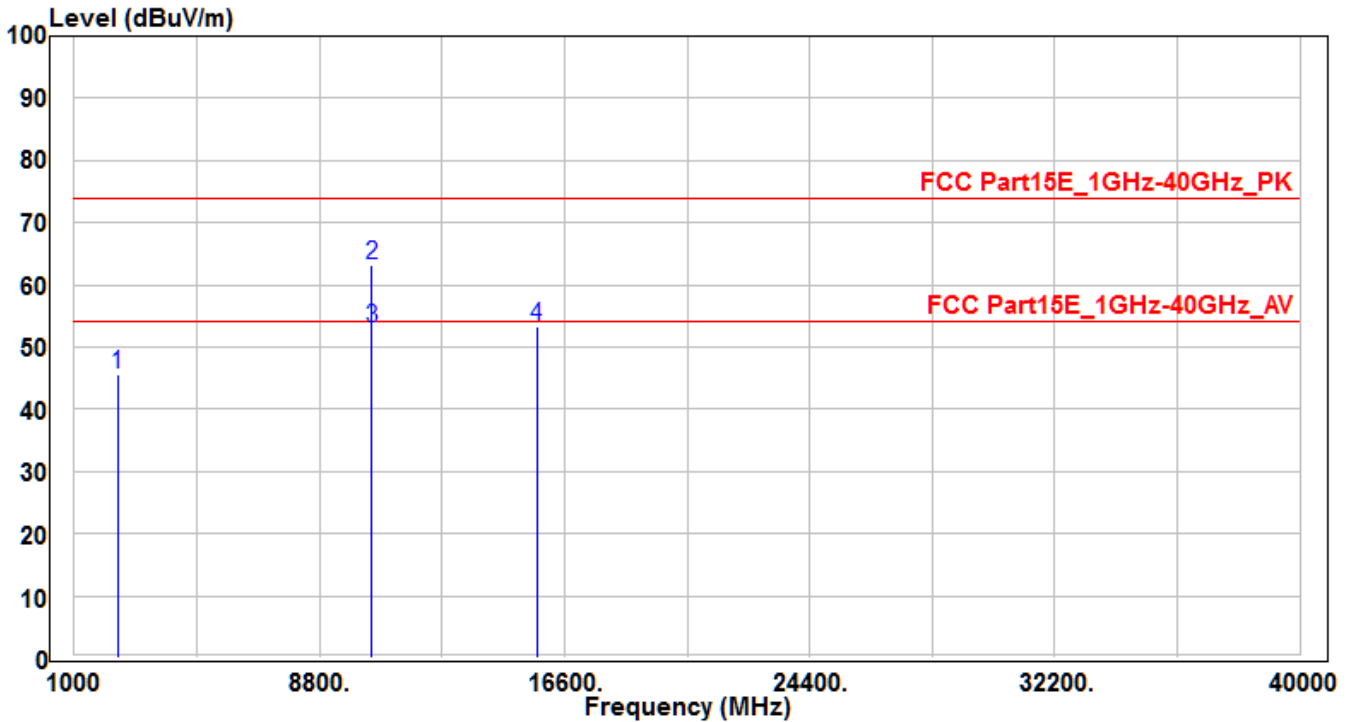

No	Frequency (MHz)	Reading (dBuV)	C.F (dB)	Measurement (dBuV/m)	Margin (dB)	Limit (dBuV)	Height (cm)	Angle (deg)	Remark (QP/PK/AV)
1	2391.37	48.29	-2.6	45.69	-28.31	74	150	400	Peak
2	* 10480	46.18	17.11	63.29	-10.71	74	150	140	Peak
3	* 10480	35.8	17.11	52.91	-1.09	54	150	140	Average
4	15720	32.02	21.37	53.39	-20.61	74	150	400	Peak

Note: The EUT Power by Notebook PC

- "*" means the worst value in this measurement data.
- Measure Level (dBuV/m) = Reading Level (dBuV) + Factor (dB)
- C.F Factor (dB) = Cable Loss (dB) + Antenna Factor (dB/m) - Preamplifier(dB).
- The emission levels of other frequencies are very lower than the limit and not show in test report.

EUT	Wireless module	Test Date	2019/6/12
Factor	BBHA 9120D & BBHA 9170	Temp. / Humidity	25°C / 60%
Polarity	Vertical	Site / Engineer	AC1 / Peter
Test Mode	MODE1 -CH48	Test Voltage	AC 120V/60Hz

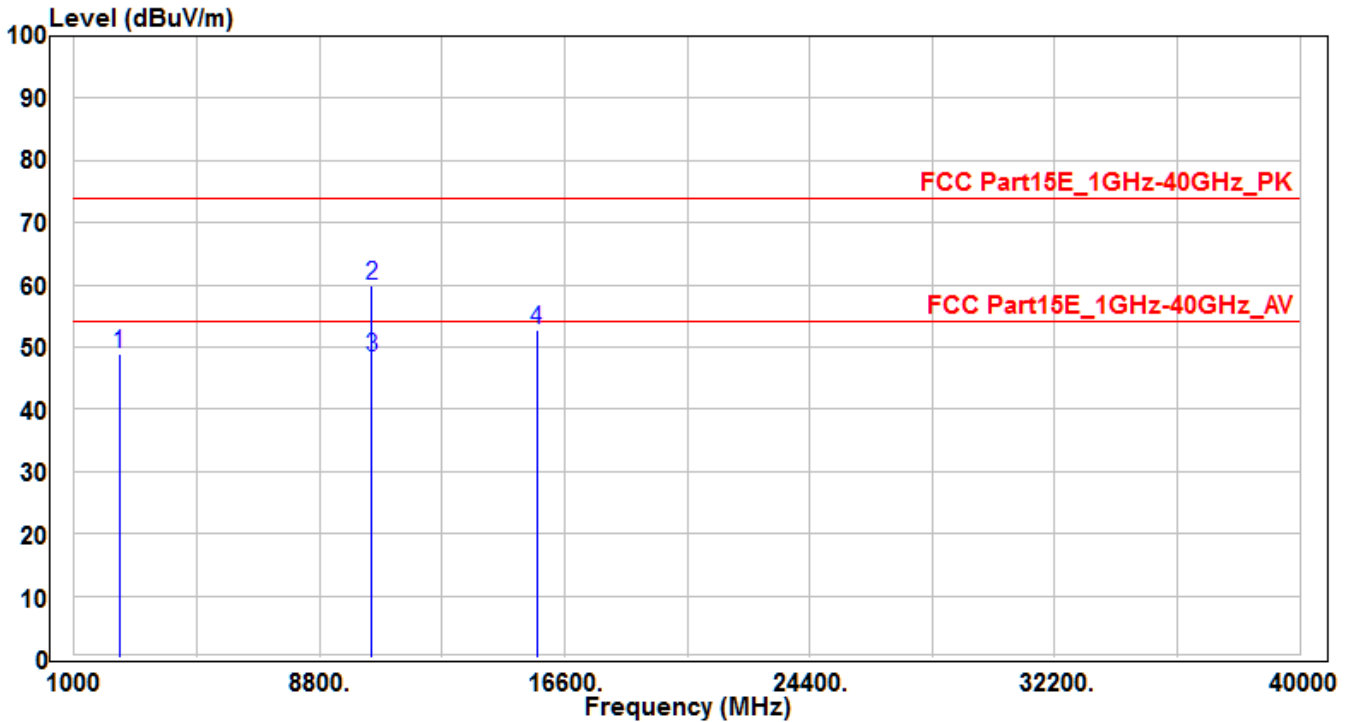

No	Frequency (MHz)	Reading (dBuV)	C.F (dB)	Measurement (dBuV/m)	Margin (dB)	Limit (dBuV)	Height (cm)	Angle (deg)	Remark (QP/PK/AV)	
1	2428.92	51.32	-2.44	48.88	-25.12	74	150	400	Peak	
2	*	10480	42.78	17.11	59.89	-14.11	74	150	190	Peak
3	*	10480	31.32	17.11	48.43	-5.57	54	150	190	Average
4		15720	31.32	21.37	52.69	-21.31	74	150	400	Peak

Note: The EUT Power by Notebook PC

- "*" means the worst value in this measurement data.
- Measure Level (dBuV/m) = Reading Level (dBuV) + Factor (dB)
- C.F Factor (dB) = Cable Loss (dB) + Antenna Factor (dB/m) - Pre-amplifier (dB).
- The emission levels of other frequencies are very lower than the limit and not show in test report.

EUT	Wireless module	Test Date	2019/6/12
Factor	BBHA 9120D & BBHA 9170	Temp. / Humidity	25°C / 60%
Polarity	Horizontal	Site / Engineer	AC1 / Peter
Test Mode	MODE1 -CH149	Test Voltage	AC 120V/60Hz

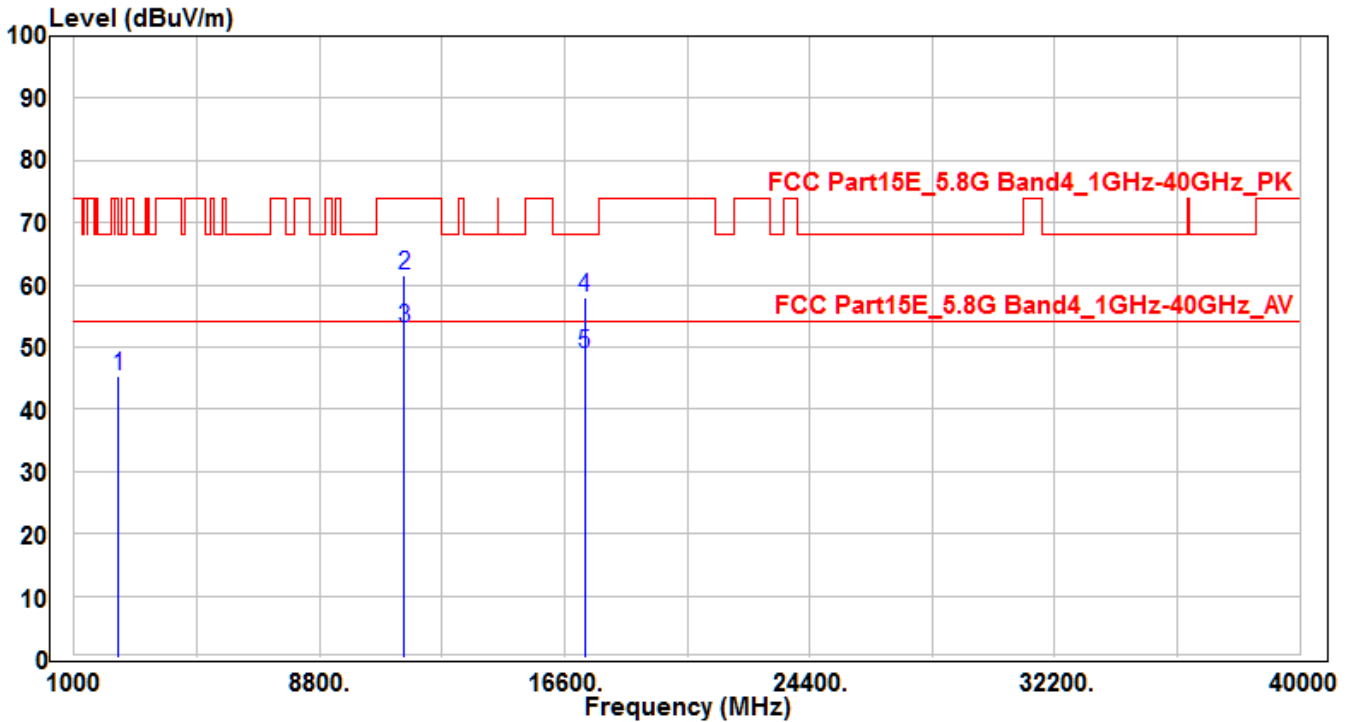

No	Frequency (MHz)	Reading (dBuV)	C.F (dB)	Measurement (dBuV/m)	Margin (dB)	Limit (dBuV)	Height (cm)	Angle (deg)	Remark (QP/PK/AV)	
1	2395.45	48.04	-2.59	45.45	-22.75	68.2	150	400	Peak	
2	*	11490	43.13	18.54	61.67	-12.33	74	150	75	Peak
3	*	11490	34.5	18.54	53.04	-0.96	54	150	75	Average
4		17235	30.12	27.82	57.94	-10.26	68.2	150	400	Peak
5		17235	21.06	27.82	48.88	-5.12	54	150	400	Average

Note: The EUT Power by Notebook PC

- "*" means the worst value in this measurement data.
- Measure Level (dBuV/m) = Reading Level (dBuV) + Factor (dB)
- C.F Factor (dB) = Cable Loss (dB) + Antenna Factor (dB/m) - Preamplifier(dB).
- The emission levels of other frequencies are very lower than the limit and not show in test report.

EUT	Wireless module	Test Date	2019/6/12
Factor	BBHA 9120D & BBHA 9170	Temp. / Humidity	25°C / 60%
Polarity	Vertical	Site / Engineer	AC1 / Peter
Test Mode	MODE1 -CH149	Test Voltage	AC 120V/60Hz

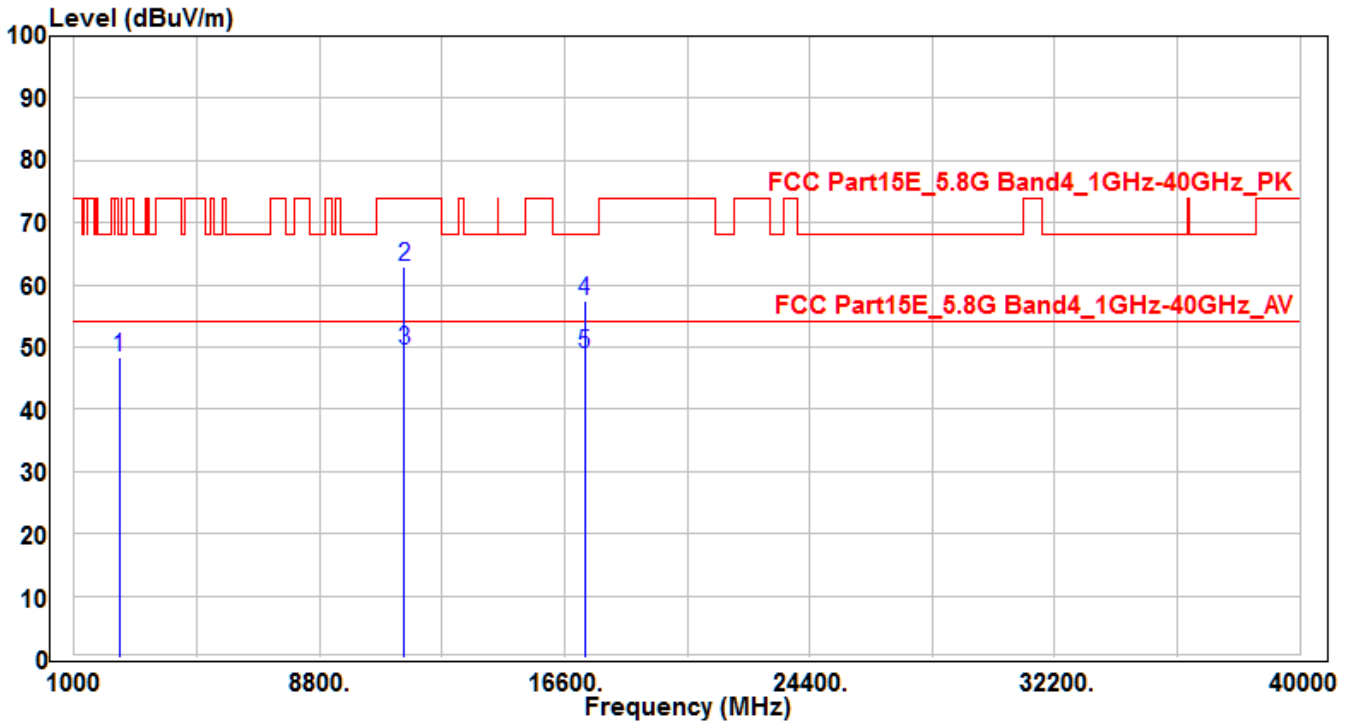

No	Frequency (MHz)	Reading (dBuV)	C.F (dB)	Measurement (dBuV/m)	Margin (dB)	Limit (dBuV)	Height (cm)	Angle (deg)	Remark (QP/PK/AV)
1	2429.5	50.76	-2.43	48.33	-19.87	68.2	150	400	Peak
2	*	11490	44.46	18.54	63	-11	74	150	Peak
3	*	11490	31.02	18.54	49.56	-4.44	54	150	Average
4		17235	29.52	27.82	57.34	-10.86	68.2	150	Peak
5		17235	21.16	27.82	48.98	-5.02	54	155	Average

Note: The EUT Power by Notebook PC

- "*" means the worst value in this measurement data.
- Measure Level (dBuV/m) = Reading Level (dBuV) + Factor (dB)
- C.F Factor (dB) = Cable Loss (dB) + Antenna Factor (dB/m) - Preamplifier(dB).
- The emission levels of other frequencies are very lower than the limit and not show in test report.

EUT	Wireless module	Test Date	2019/6/12
Factor	BBHA 9120D & BBHA 9170	Temp. / Humidity	25°C / 60%
Polarity	Horizontal	Site / Engineer	AC1 / Peter
Test Mode	MODE1 -CH157	Test Voltage	AC 120V/60Hz

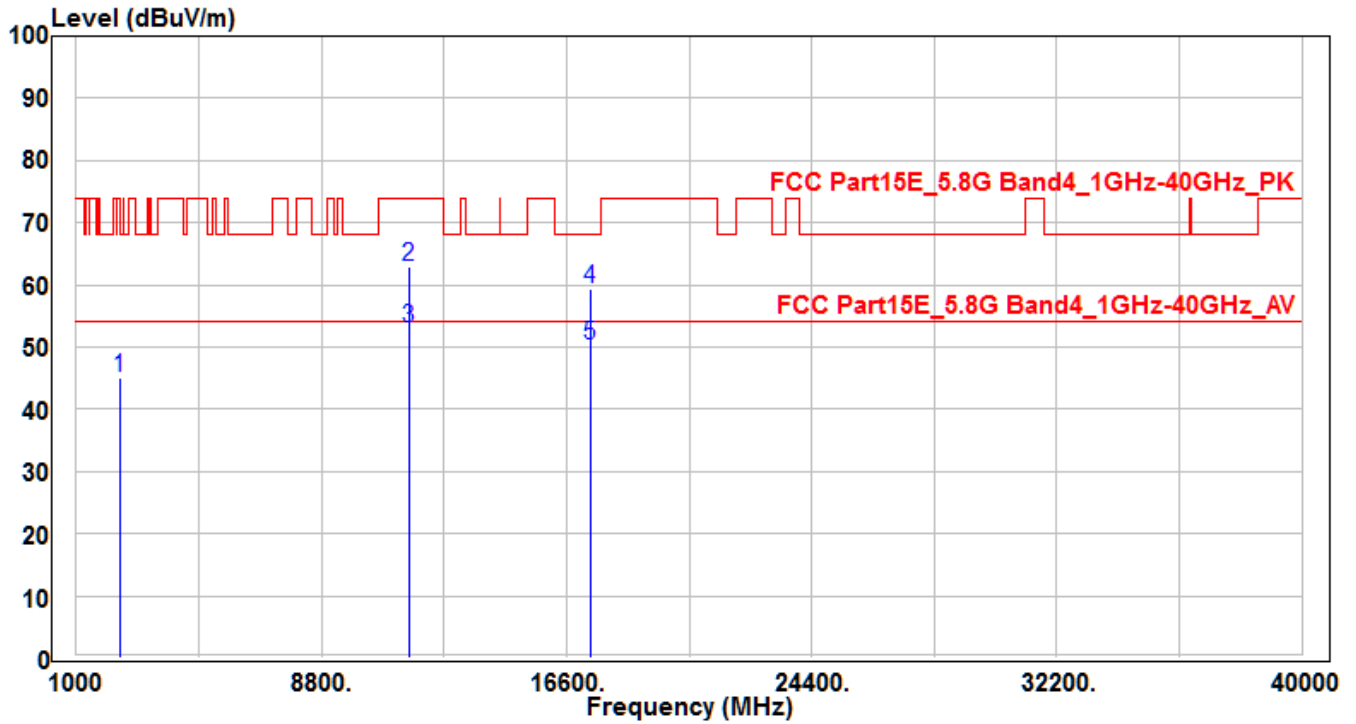

No	Frequency (MHz)	Reading (dBuV)	C.F (dB)	Measurement (dBuV/m)	Margin (dB)	Limit (dBuV)	Height (cm)	Angle (deg)	Remark (QP/PK/AV)	
1	2388.67	47.8	-2.61	45.19	-28.81	74	150	400	Peak	
2	*	11570	44.51	18.49	63	-11	74	150	75	Peak
3	*	11570	34.6	18.49	53.09	-0.91	54	150	75	Average
4		17355	30.26	29	59.26	-8.94	68.2	150	400	Peak
5		17355	21.25	29	50.25	-3.75	54	150	400	Average

Note: The EUT Power by Notebook PC

- "*" means the worst value in this measurement data.
- Measure Level (dBuV/m) = Reading Level (dBuV) + Factor (dB)
- C.F Factor (dB) = Cable Loss (dB) + Antenna Factor (dB/m) - Preamplifier(dB).
- The emission levels of other frequencies are very lower than the limit and not show in test report.

EUT	Wireless module	Test Date	2019/6/12
Factor	BBHA 9120D & BBHA 9170	Temp. / Humidity	25°C / 60%
Polarity	Vertical	Site / Engineer	AC1 / Peter
Test Mode	MODE1 -CH157	Test Voltage	AC 120V/60Hz

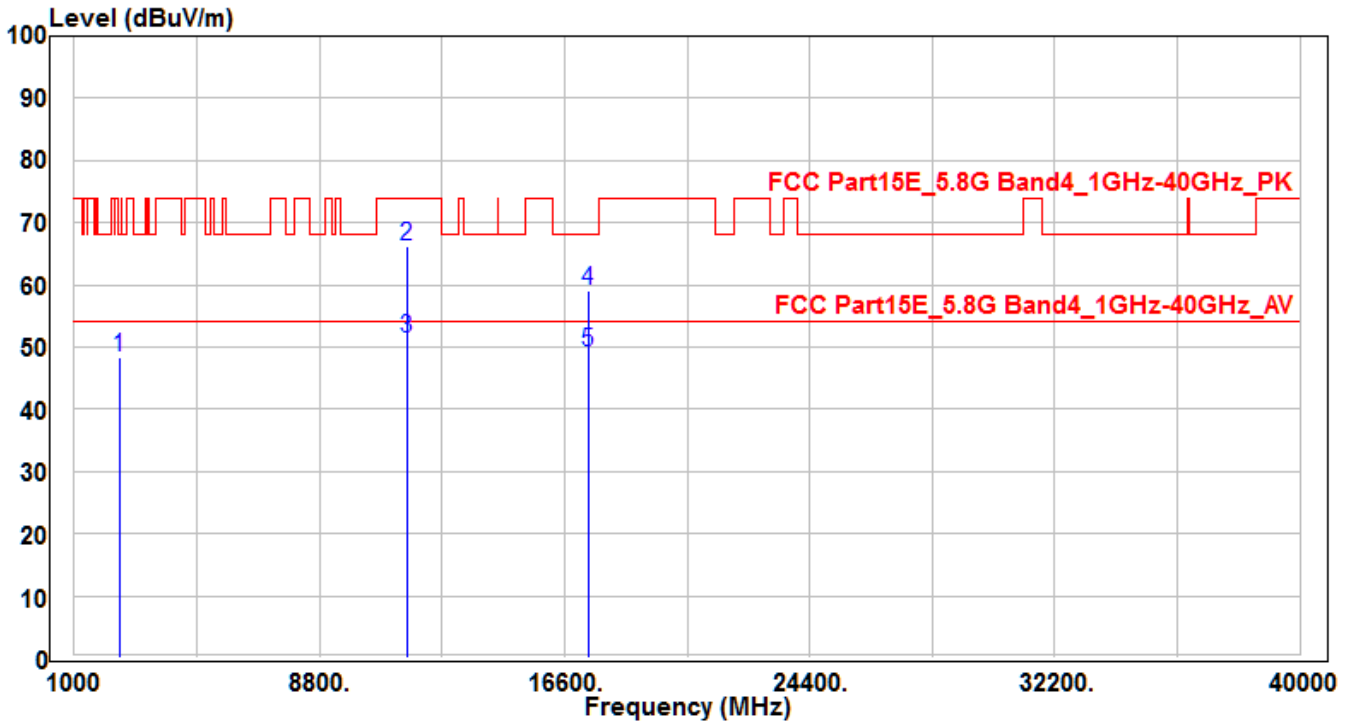

No	Frequency (MHz)	Reading (dBuV)	C.F (dB)	Measurement (dBuV/m)	Margin (dB)	Limit (dBuV)	Height (cm)	Angle (deg)	Remark (QP/PK/AV)
1	2428.61	50.85	-2.44	48.41	-19.79	68.2	150	400	Peak
2	*	47.84	18.49	66.33	-7.67	74	150	190	Peak
3	*	32.9	18.49	51.39	-2.61	54	150	190	Average
4	17355	30.07	29	59.07	-9.13	68.2	150	380	Peak
5	17355	20.14	29	49.14	-4.86	54	155	380	Average

Note: The EUT Power by Notebook PC

- "*" means the worst value in this measurement data.
- Measure Level (dBuV/m) = Reading Level (dBuV) + Factor (dB)
- C.F Factor (dB) = Cable Loss (dB) + Antenna Factor (dB/m) - Preamplifier(dB).
- The emission levels of other frequencies are very lower than the limit and not show in test report.

EUT	Wireless module	Test Date	2019/6/12
Factor	BBHA 9120D & BBHA 9170	Temp. / Humidity	25°C / 60%
Polarity	Horizontal	Site / Engineer	AC1 / Peter
Test Mode	MODE1 -CH165	Test Voltage	AC 120V/60Hz

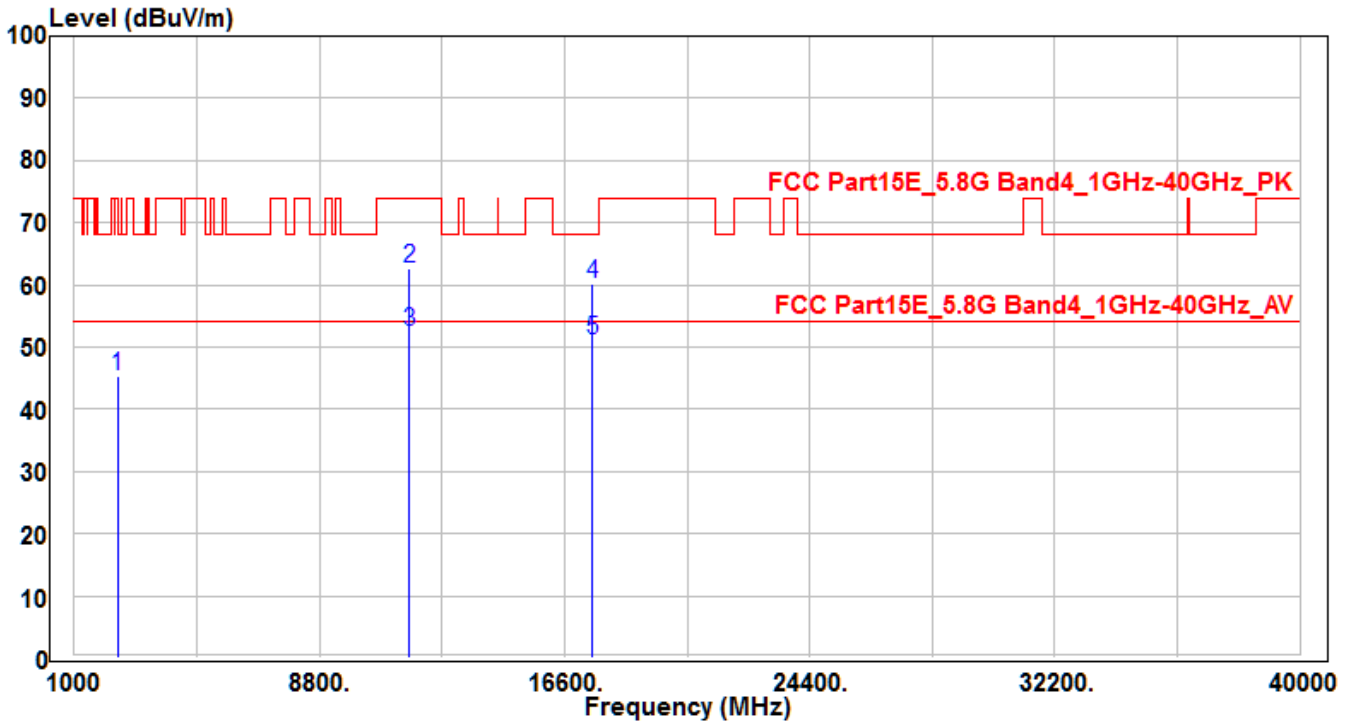

No	Frequency (MHz)	Reading (dBuV)	C.F (dB)	Measurement (dBuV/m)	Margin (dB)	Limit (dBuV)	Height (cm)	Angle (deg)	Remark (QP/PK/AV)	
1	2392.56	47.87	-2.6	45.27	-22.93	68.2	150	400	Peak	
2	*	11650	44.13	18.42	62.55	-11.45	74	150	75	Peak
3	*	11650	34	18.42	52.42	-1.58	54	150	75	Average
4		17475	29.87	30.18	60.05	-8.15	68.2	150	400	Peak
5		17475	20.89	30.18	51.07	-2.93	54	150	400	Average

Note: The EUT Power by Notebook PC

- "*" means the worst value in this measurement data.
- Measure Level (dBuV/m) = Reading Level (dBuV) + Factor (dB)
- C.F Factor (dB) = Cable Loss (dB) + Antenna Factor (dB/m) - Preamplifier(dB).
- The emission levels of other frequencies are very lower than the limit and not show in test report.

EUT	Wireless module	Test Date	2019/6/12
Factor	BBHA 9120D & BBHA 9170	Temp. / Humidity	25°C / 60%
Polarity	Vertical	Site / Engineer	AC1 / Peter
Test Mode	MODE1 -CH165	Test Voltage	AC 120V/60Hz

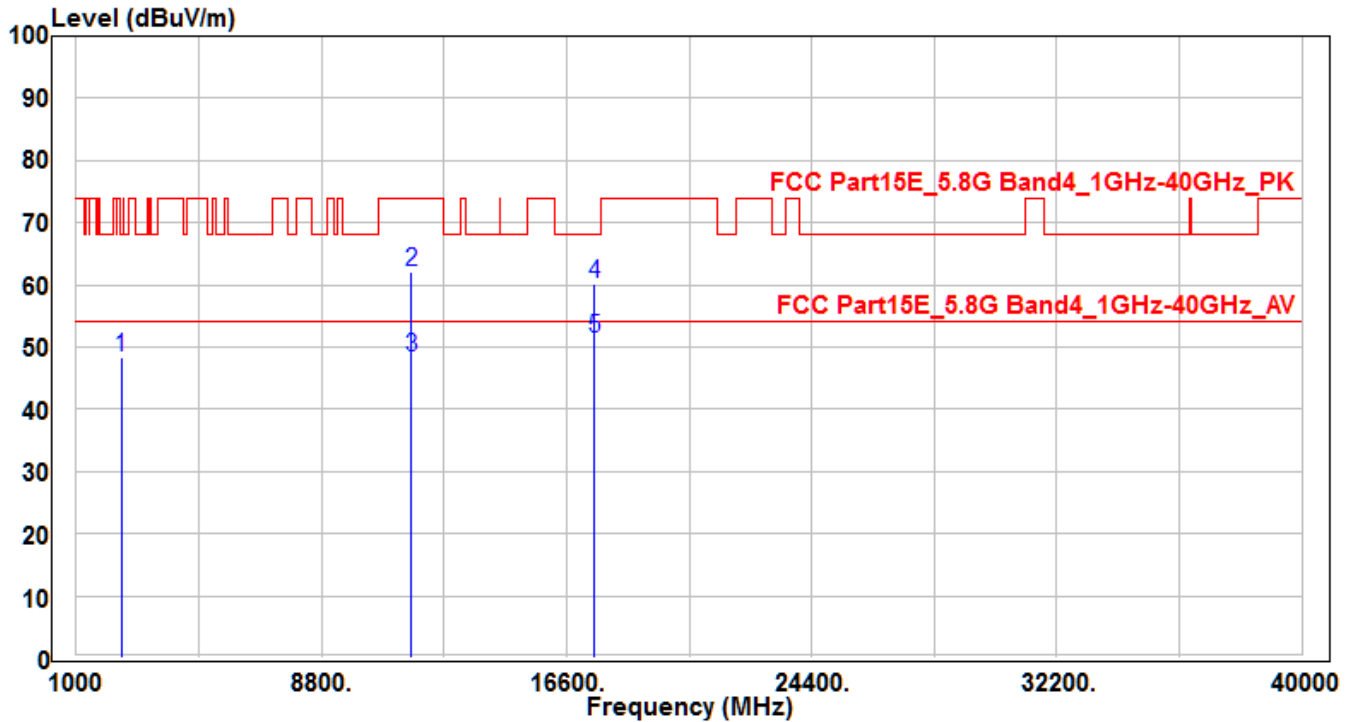

No	Frequency (MHz)	Reading (dBuV)	C.F (dB)	Measurement (dBuV/m)	Margin (dB)	Limit (dBuV)	Height (cm)	Angle (deg)	Remark (QP/PK/AV)
1	2425.23	50.94	-2.45	48.49	-19.71	68.2	150	400	Peak
2	11650	43.81	18.42	62.23	-11.77	74	150	190	Peak
3	11650	30.02	18.42	48.44	-5.56	54	150	190	Average
4	* 17475	29.94	30.18	60.12	-8.08	68.2	155	380	Peak
5	* 17475	21.24	30.18	51.42	-2.58	54	155	380	Average

Note: The EUT Power by Notebook PC

1. " * " means the worst value in this measurement data.
2. Measure Level (dBuV/m) = Reading Level (dBuV) + Factor (dB)
3. C.F Factor (dB) = Cable Loss (dB) + Antenna Factor (dB/m) - Preamplifier(dB).
4. The emission levels of other frequencies are very lower than the limit and not show in test report.

EUT	Wireless module	Test Date	2019/6/12
Factor	BBHA 9120D & BBHA 9170	Temp. / Humidity	25°C / 60%
Polarity	Horizontal	Site / Engineer	AC1 / Peter
Test Mode	MODE2 -CH36	Test Voltage	AC 120V/60Hz

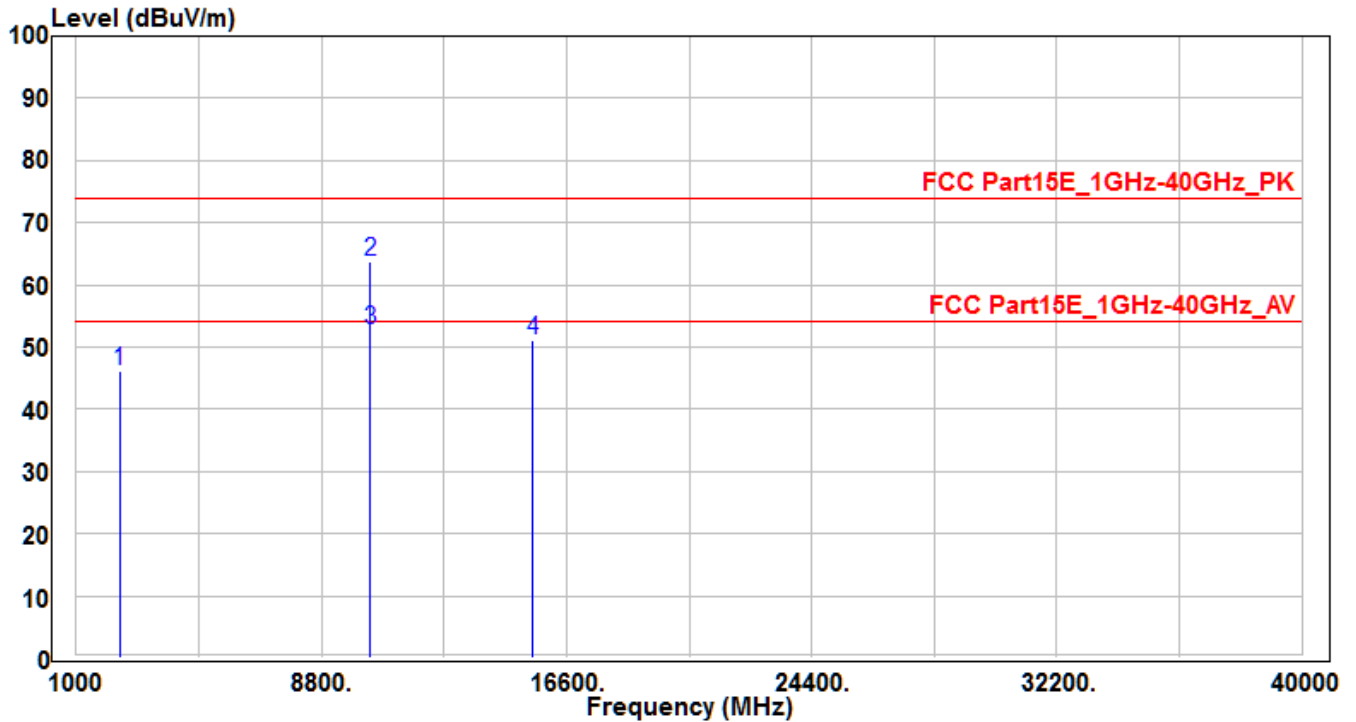

No	Frequency (MHz)	Reading (dBuV)	C.F (dB)	Measurement (dBuV/m)	Margin (dB)	Limit (dBuV)	Height (cm)	Angle (deg)	Remark (QP/PK/AV)	
1	2388.17	48.68	-2.61	46.07	-27.93	74	150	400	Peak	
2	*	10360	46.92	16.74	63.66	-10.34	74	150	140	Peak
3	*	10360	36.11	16.74	52.85	-1.15	54	150	140	Average
4		15540	29.33	21.69	51.02	-22.98	74	150	400	Peak

Note: The EUT Power by Notebook PC

- "*" means the worst value in this measurement data.
- Measure Level (dB μ V/m) = Reading Level (dB μ V) + Factor (dB)
- C.F Factor (dB) = Cable Loss (dB) + Antenna Factor (dB/m) - Pre-amplifier (dB).
- The emission levels of other frequencies are very lower than the limit and not show in test report.

EUT	Wireless module	Test Date	2019/6/12
Factor	BBHA 9120D & BBHA 9170	Temp. / Humidity	25°C / 60%
Polarity	Vertical	Site / Engineer	AC1 / Peter
Test Mode	MODE2 -CH36	Test Voltage	AC 120V/60Hz

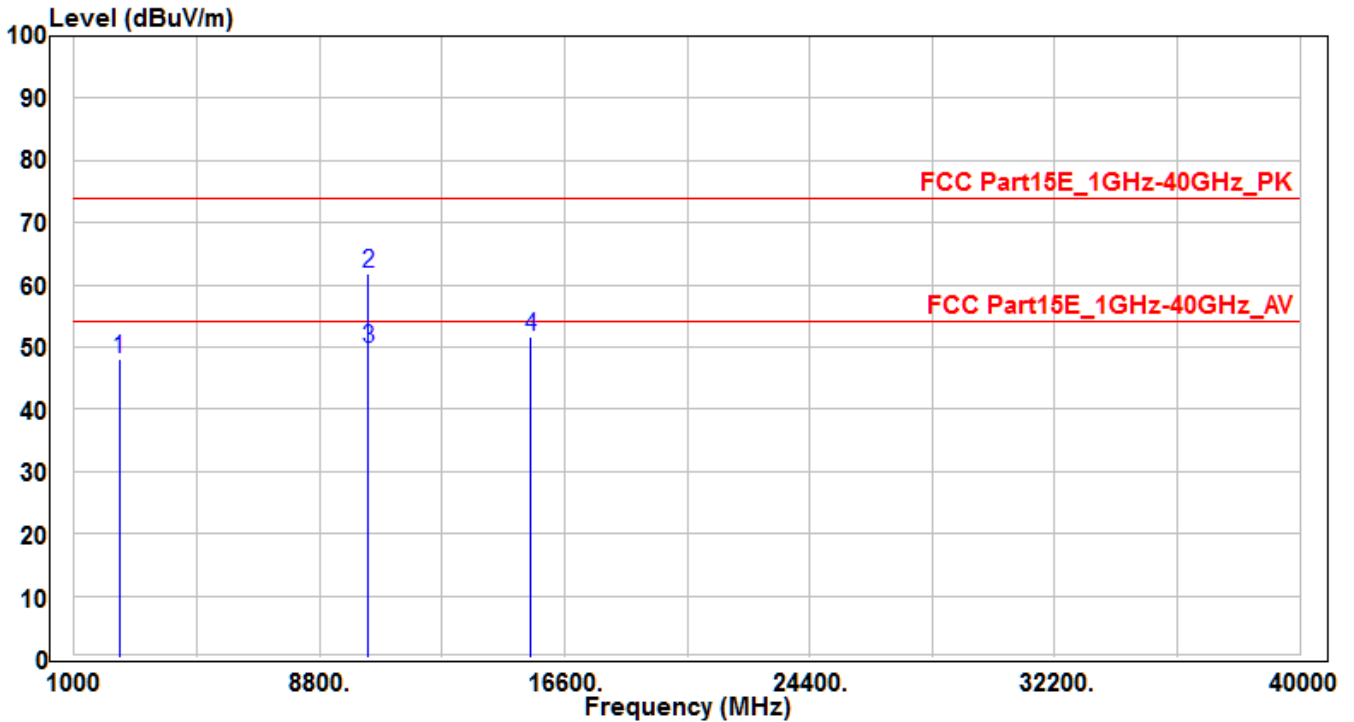

No	Frequency (MHz)	Reading (dBuV)	C.F (dB)	Measurement (dBuV/m)	Margin (dB)	Limit (dBuV)	Height (cm)	Angle (deg)	Remark (QP/PK/AV)
1	2426.25	50.67	-2.45	48.22	-25.78	74	150	400	Peak
2	*	10360	45.11	16.74	61.85	-12.15	74	150	Peak
3	*	10360	33.11	16.74	49.85	-4.15	54	150	Average
4		15540	30.01	21.69	51.7	-22.3	74	150	Peak

Note: The EUT Power by Notebook PC

1. " * " means the worst value in this measurement data.
2. Measure Level (dBuV/m) = Reading Level (dBuV) + Factor (dB)
3. C.F Factor (dB) = Cable Loss (dB) + Antenna Factor (dB/m) - Pre-amplifier(dB).
4. The emission levels of other frequencies are very lower than the limit and not show in test report.

EUT	Wireless module	Test Date	2019/6/12
Factor	BBHA 9120D & BBHA 9170	Temp. / Humidity	25°C / 60%
Polarity	Horizontal	Site / Engineer	AC1 / Peter
Test Mode	MODE2 -CH44	Test Voltage	AC 120V/60Hz

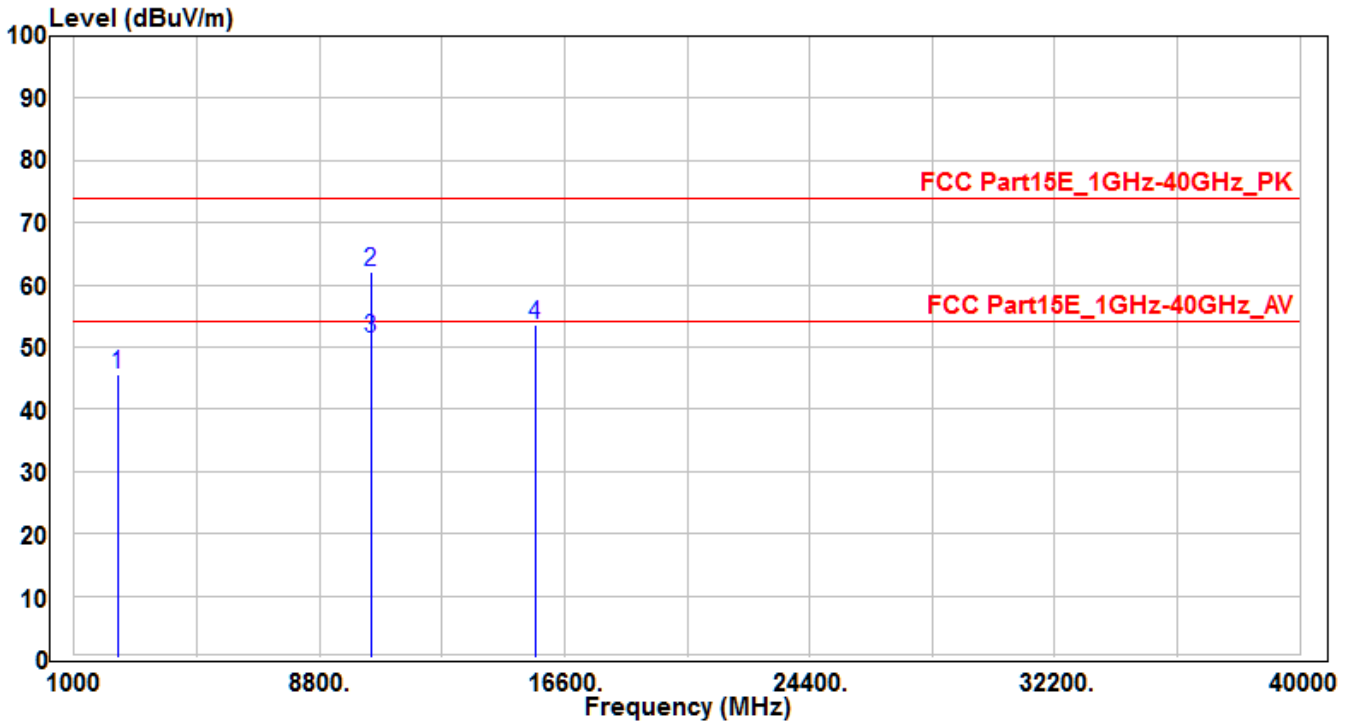

No	Frequency (MHz)	Reading (dBuV)	C.F (dB)	Measurement (dBuV/m)	Margin (dB)	Limit (dBuV)	Height (cm)	Angle (deg)	Remark (QP/PK/AV)	
1	2387.28	48.19	-2.62	45.57	-28.43	74	150	400	Peak	
2	*	10440	45.21	16.99	62.2	-11.8	74	150	140	Peak
3	*	10440	34.5	16.99	51.49	-2.51	54	150	140	Average
4		15660	32.09	21.48	53.57	-20.43	74	150	400	Peak

Note: The EUT Power by Notebook PC

1. " * " means the worst value in this measurement data.
2. Measure Level (dBuV/m) = Reading Level (dBuV) + Factor (dB)
3. C.F Factor (dB) = Cable Loss (dB) + Antenna Factor (dB/m) - Pre-amplifier(dB).
4. The emission levels of other frequencies are very lower than the limit and not show in test report.

EUT	Wireless module	Test Date	2019/6/12
Factor	BBHA 9120D & BBHA 9170	Temp. / Humidity	25°C / 60%
Polarity	Vertical	Site / Engineer	AC1 / Peter
Test Mode	MODE2 -CH44	Test Voltage	AC 120V/60Hz

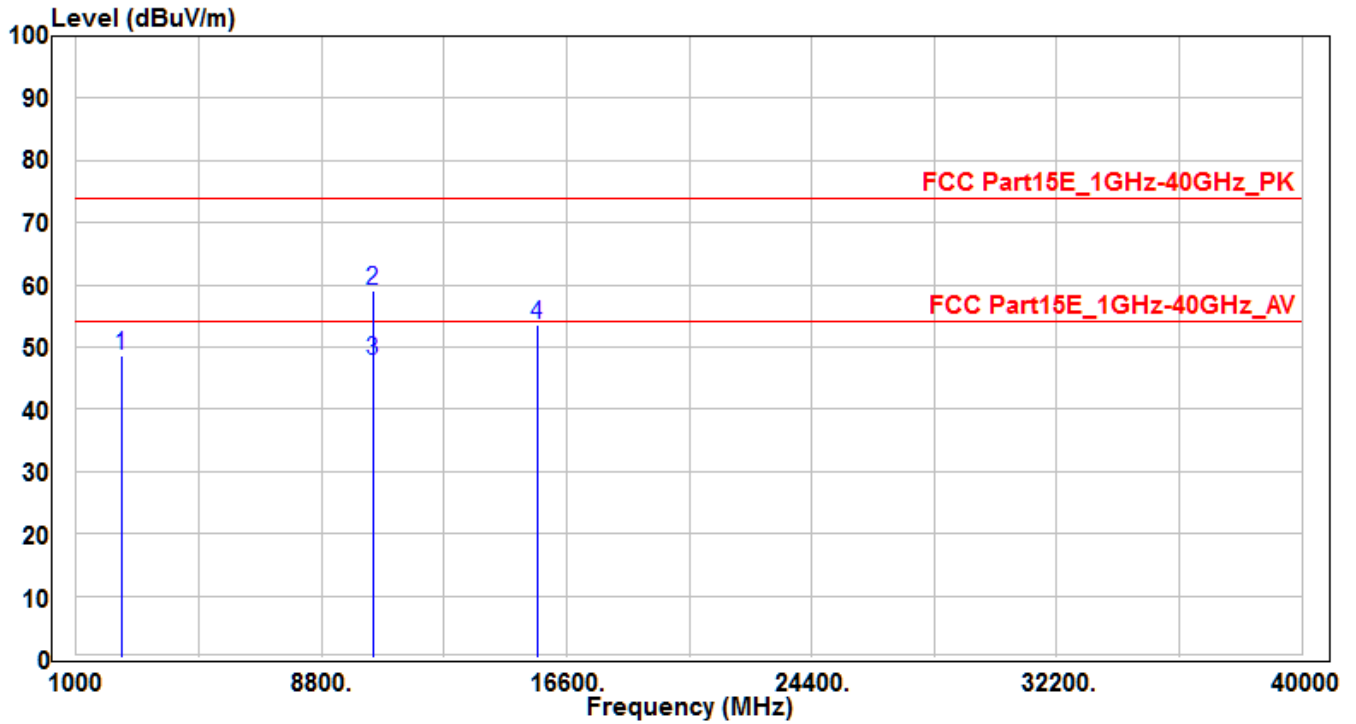

No	Frequency (MHz)	Reading (dBuV)	C.F (dB)	Measurement (dBuV/m)	Margin (dB)	Limit (dBuV)	Height (cm)	Angle (deg)	Remark (QP/PK/AV)
1	2430.58	51.04	-2.43	48.61	-25.39	74	150	400	Peak
2	*	10440	41.98	16.99	58.97	-15.03	74	150	Peak
3	*	10440	30.7	16.99	47.69	-6.31	54	150	Average
4		15660	32	21.48	53.48	-20.52	74	150	Peak

Note: The EUT Power by Notebook PC

1. " * " means the worst value in this measurement data.
2. Measure Level (dBuV/m) = Reading Level (dBuV) + Factor (dB)
3. C.F Factor (dB) = Cable Loss (dB) + Antenna Factor (dB/m) - Pre-amplifier(dB).
4. The emission levels of other frequencies are very lower than the limit and not show in test report.

EUT	Wireless module	Test Date	2019/6/12
Factor	BBHA 9120D & BBHA 9170	Temp. / Humidity	25°C / 60%
Polarity	Horizontal	Site / Engineer	AC1 / Peter
Test Mode	MODE2 -CH48	Test Voltage	AC 120V/60Hz

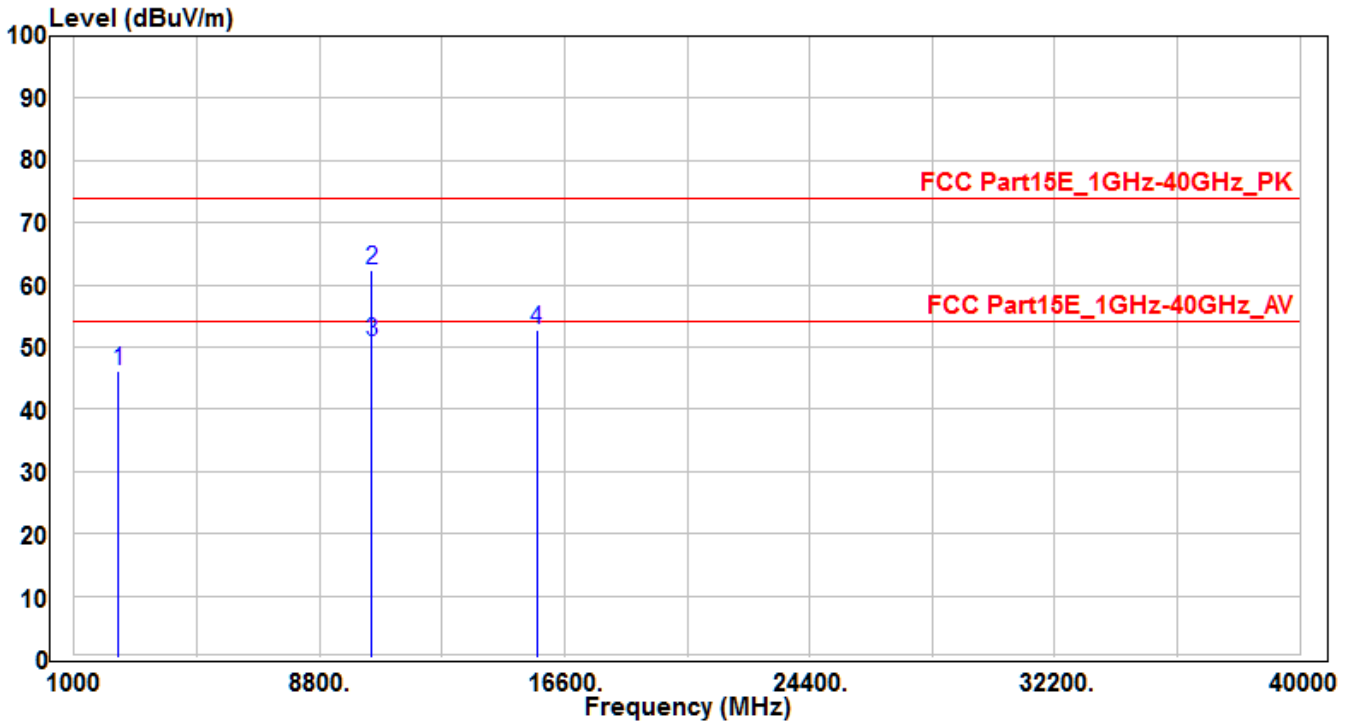

No	Frequency (MHz)	Reading (dBuV)	C.F (dB)	Measurement (dBuV/m)	Margin (dB)	Limit (dBuV)	Height (cm)	Angle (deg)	Remark (QP/PK/AV)	
1	2398.38	48.65	-2.57	46.08	-27.92	74	150	400	Peak	
2	*	10480	45.15	17.11	62.26	-11.74	74	150	140	Peak
3	*	10480	33.6	17.11	50.71	-3.29	54	150	140	Average
4		15720	31.33	21.37	52.7	-21.3	74	150	400	Peak

Note: The EUT Power by Notebook PC

1. " * " means the worst value in this measurement data.
2. Measure Level (dBuV/m) = Reading Level (dBuV) + Factor (dB)
3. C.F Factor (dB) = Cable Loss (dB) + Antenna Factor (dB/m) - Preamplifier(dB).
4. The emission levels of other frequencies are very lower than the limit and not show in test report.

EUT	Wireless module	Test Date	2019/6/12
Factor	BBHA 9120D & BBHA 9170	Temp. / Humidity	25°C / 60%
Polarity	Vertical	Site / Engineer	AC1 / Peter
Test Mode	MODE2 -CH48	Test Voltage	AC 120V/60Hz

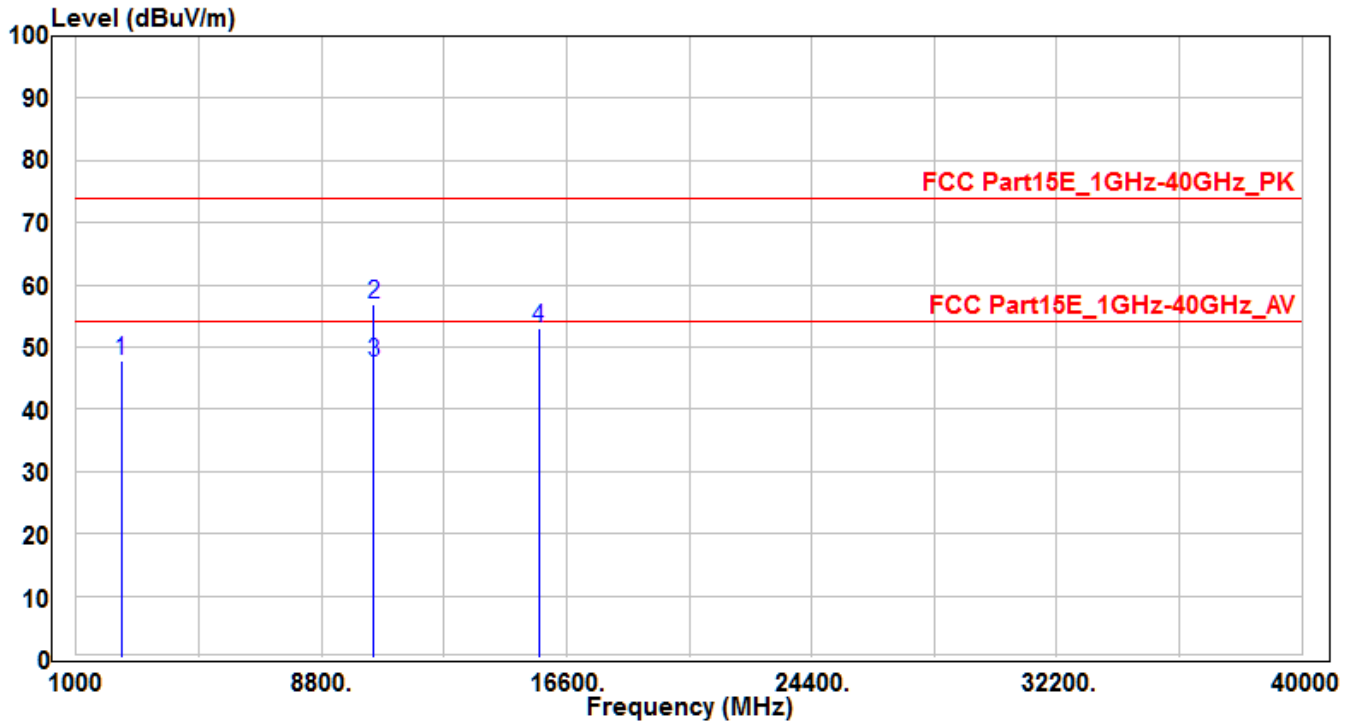

No	Frequency (MHz)	Reading (dBuV)	C.F (dB)	Measurement (dBuV/m)	Margin (dB)	Limit (dBuV)	Height (cm)	Angle (deg)	Remark (QP/PK/AV)
1	2435.14	50.27	-2.41	47.86	-26.14	74	150	400	Peak
2	* 10480	39.84	17.11	56.95	-17.05	74	150	190	Peak
3	* 10480	30.3	17.11	47.41	-6.59	54	150	190	Average
4	15720	31.54	21.37	52.91	-21.09	74	150	400	Peak

Note: The EUT Power by Notebook PC

- "*" means the worst value in this measurement data.
- Measure Level (dBuV/m) = Reading Level (dBuV) + Factor (dB)
- C.F Factor (dB) = Cable Loss (dB) + Antenna Factor (dB/m) - Preamplifier(dB).
- The emission levels of other frequencies are very lower than the limit and not show in test report.

EUT	Wireless module	Test Date	2019/6/12
Factor	BBHA 9120D & BBHA 9170	Temp. / Humidity	25°C / 60%
Polarity	Horizontal	Site / Engineer	AC1 / Peter
Test Mode	MODE2 -CH149	Test Voltage	AC 120V/60Hz

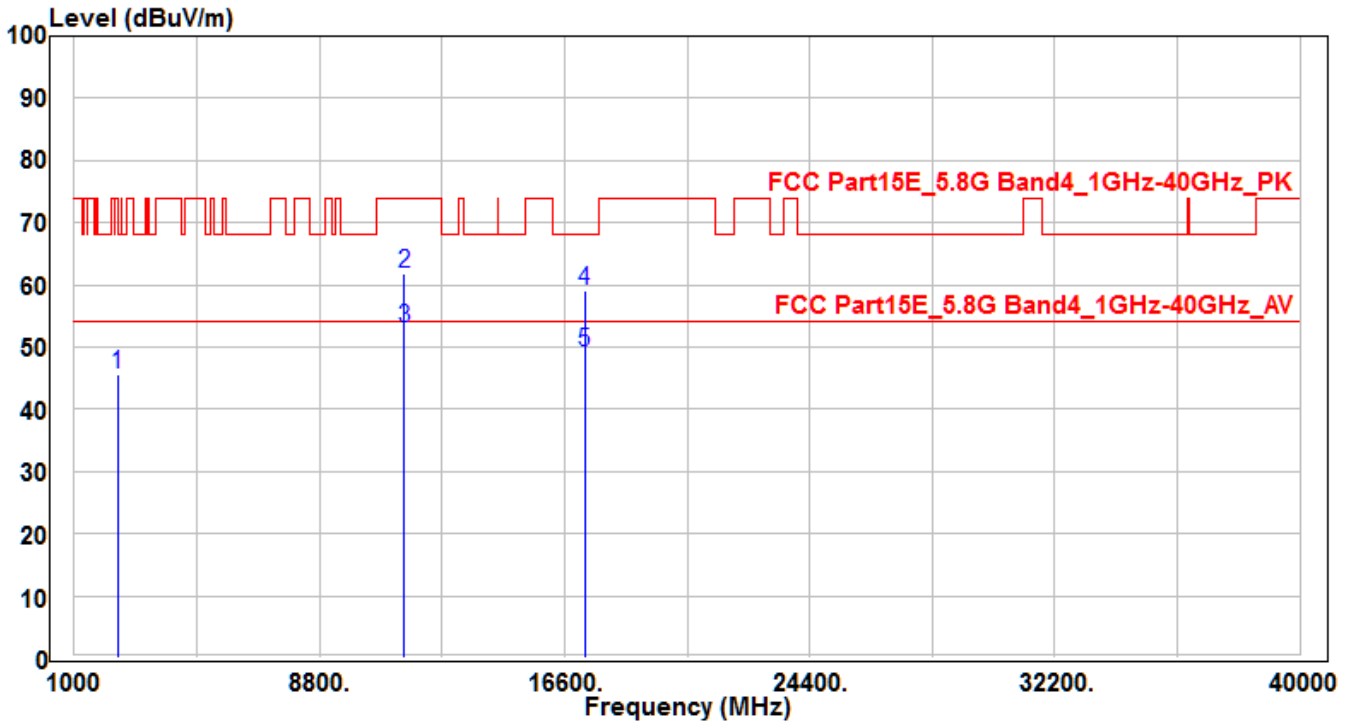

No	Frequency (MHz)	Reading (dBuV)	C.F (dB)	Measurement (dBuV/m)	Margin (dB)	Limit (dBuV)	Height (cm)	Angle (deg)	Remark (QP/PK/AV)
1	2386.54	48.24	-2.63	45.61	-28.39	74	150	400	Peak
2	* 11490	43.31	18.54	61.85	-12.15	74	150	75	Peak
3	* 11490	34.5	18.54	53.04	-0.96	54	150	75	Average
4	17235	31.13	27.82	58.95	-9.25	68.2	150	400	Peak
5	17235	21.36	27.82	49.18	-4.82	54	150	400	Average

Note: The EUT Power by Notebook PC

- "*" means the worst value in this measurement data.
- Measure Level (dBuV/m) = Reading Level (dBuV) + Factor (dB)
- C.F Factor (dB) = Cable Loss (dB) + Antenna Factor (dB/m) - Preamplifier(dB).
- The emission levels of other frequencies are very lower than the limit and not show in test report.

EUT	Wireless module	Test Date	2019/6/12
Factor	BBHA 9120D & BBHA 9170	Temp. / Humidity	25°C / 60%
Polarity	Vertical	Site / Engineer	AC1 / Peter
Test Mode	MODE2 -CH149	Test Voltage	AC 120V/60Hz

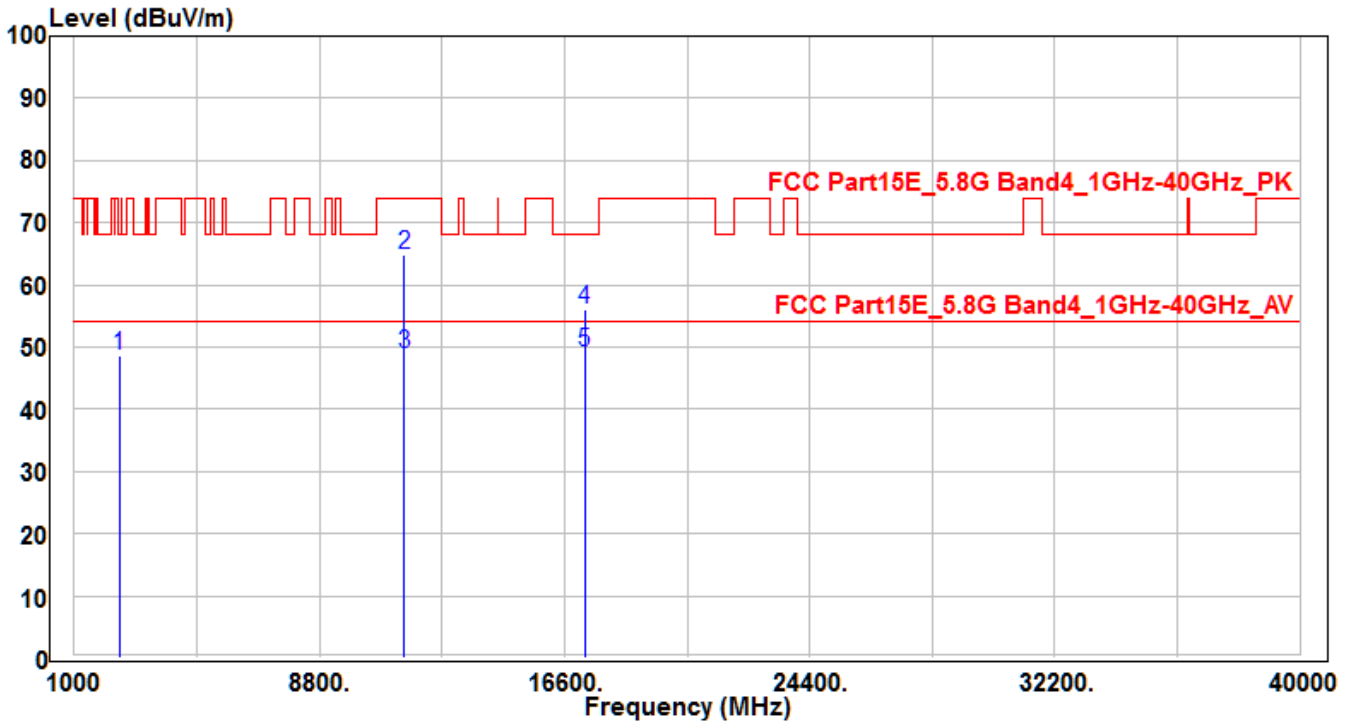

No	Frequency (MHz)	Reading (dBuV)	C.F (dB)	Measurement (dBuV/m)	Margin (dB)	Limit (dBuV)	Height (cm)	Angle (deg)	Remark (QP/PK/AV)
1	2426.91	51.14	-2.45	48.69	-19.51	68.2	150	400	Peak
2	11490	46.26	18.54	64.8	-9.2	74	150	190	Peak
3	11490	30.46	18.54	49	-5	54	150	190	Average
4	* 17235	28.3	27.82	56.12	-12.08	68.2	155	380	Peak
5	* 17235	21.24	27.82	49.06	-4.94	54	155	380	Average

Note: The EUT Power by Notebook PC

1. " * " means the worst value in this measurement data.
2. Measure Level (dBuV/m) = Reading Level (dBuV) + Factor (dB)
3. C.F Factor (dB) = Cable Loss (dB) + Antenna Factor (dB/m) - Preamplifier(dB).
4. The emission levels of other frequencies are very lower than the limit and not show in test report.

EUT	Wireless module	Test Date	2019/6/12
Factor	BBHA 9120D & BBHA 9170	Temp. / Humidity	25°C / 60%
Polarity	Horizontal	Site / Engineer	AC1 / Peter
Test Mode	MODE2 -CH157	Test Voltage	AC 120V/60Hz

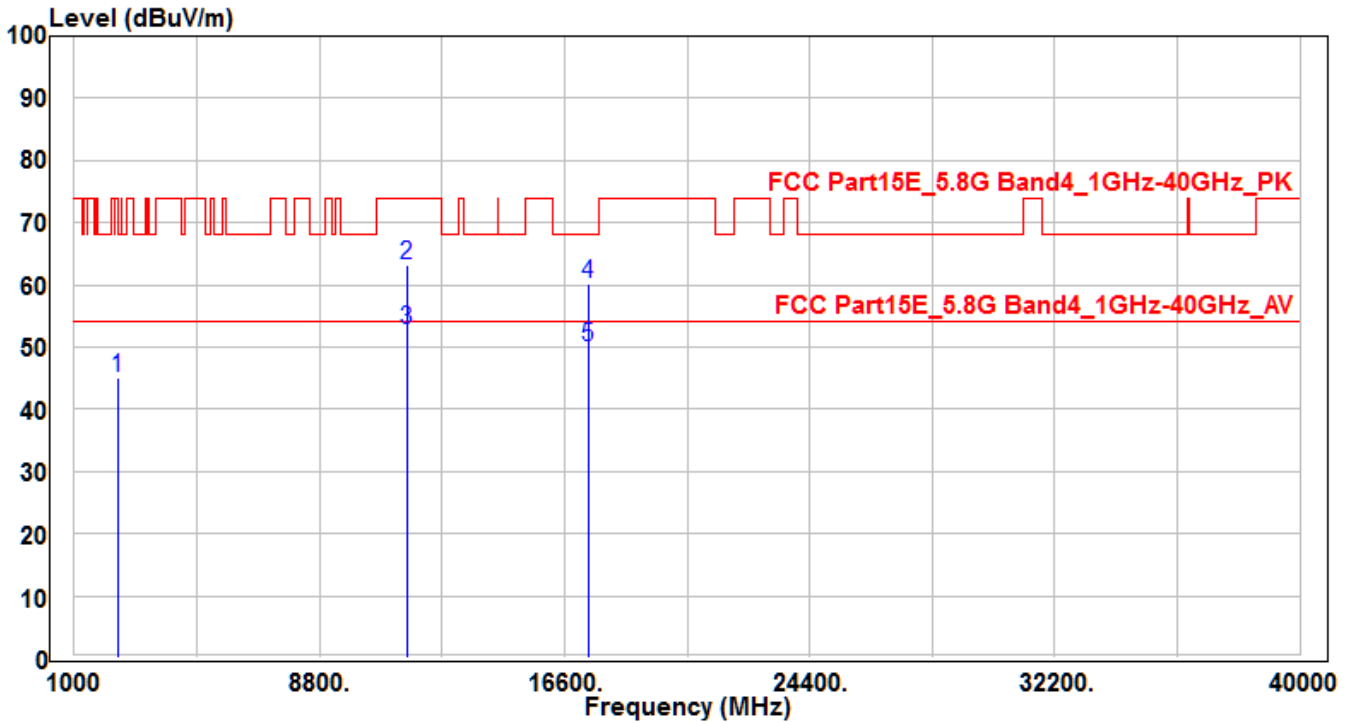

No	Frequency (MHz)	Reading (dBuV)	C.F (dB)	Measurement (dBuV/m)	Margin (dB)	Limit (dBuV)	Height (cm)	Angle (deg)	Remark (QP/PK/AV)	
1	2391.27	47.79	-2.6	45.19	-23.01	68.2	150	400	Peak	
2	*	11570	44.59	18.49	63.08	-10.92	74	150	75	Peak
3	*	11570	34.4	18.49	52.89	-1.11	54	150	75	Average
4		17355	31.12	29	60.12	-8.08	68.2	150	400	Peak
5		17355	20.98	29	49.98	-4.02	54	150	400	Average

Note: The EUT Power by Notebook PC

- "*" means the worst value in this measurement data.
- Measure Level (dBuV/m) = Reading Level (dBuV) + Factor (dB)
- C.F Factor (dB) = Cable Loss (dB) + Antenna Factor (dB/m) - Preamplifier(dB).
- The emission levels of other frequencies are very lower than the limit and not show in test report.

EUT	Wireless module	Test Date	2019/6/12
Factor	BBHA 9120D & BBHA 9170	Temp. / Humidity	25°C / 60%
Polarity	Vertical	Site / Engineer	AC1 / Peter
Test Mode	MODE2 -CH157	Test Voltage	AC 120V/60Hz

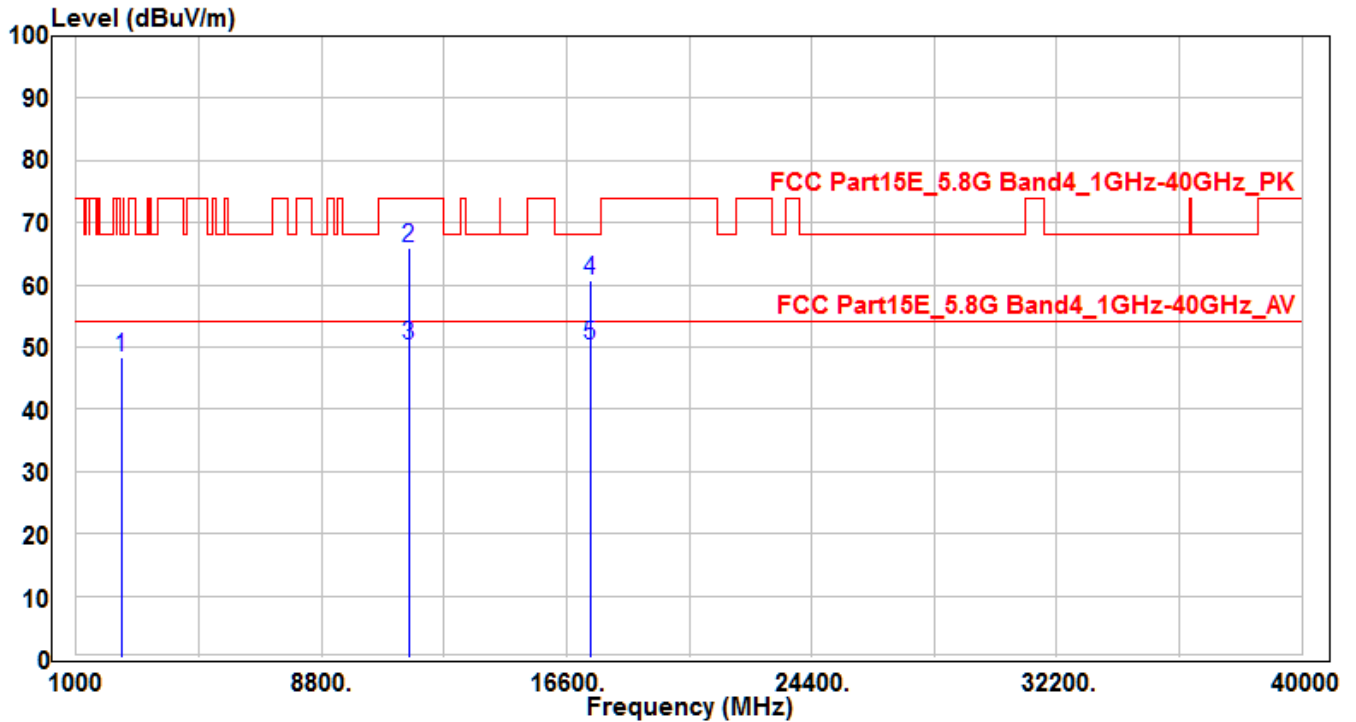

No	Frequency (MHz)	Reading (dBuV)	C.F (dB)	Measurement (dBuV/m)	Margin (dB)	Limit (dBuV)	Height (cm)	Angle (deg)	Remark (QP/PK/AV)
1	2430.62	50.75	-2.43	48.32	-19.88	68.2	150	400	Peak
2	*	47.45	18.49	65.94	-8.06	74	150	190	Peak
3	*	31.9	18.49	50.39	-3.61	54	150	190	Average
4	17355	31.63	29	60.63	-7.57	68.2	155	380	Peak
5	17355	21.34	29	50.34	-3.66	54	155	380	Average

Note: The EUT Power by Notebook PC

- "*" means the worst value in this measurement data.
- Measure Level (dBuV/m) = Reading Level (dBuV) + Factor (dB)
- C.F Factor (dB) = Cable Loss (dB) + Antenna Factor (dB/m) - Preamplifier(dB).
- The emission levels of other frequencies are very lower than the limit and not show in test report.

EUT	Wireless module	Test Date	2019/6/12
Factor	BBHA 9120D & BBHA 9170	Temp. / Humidity	25°C / 60%
Polarity	Horizontal	Site / Engineer	AC1 / Peter
Test Mode	MODE2 -CH165	Test Voltage	AC 120V/60Hz

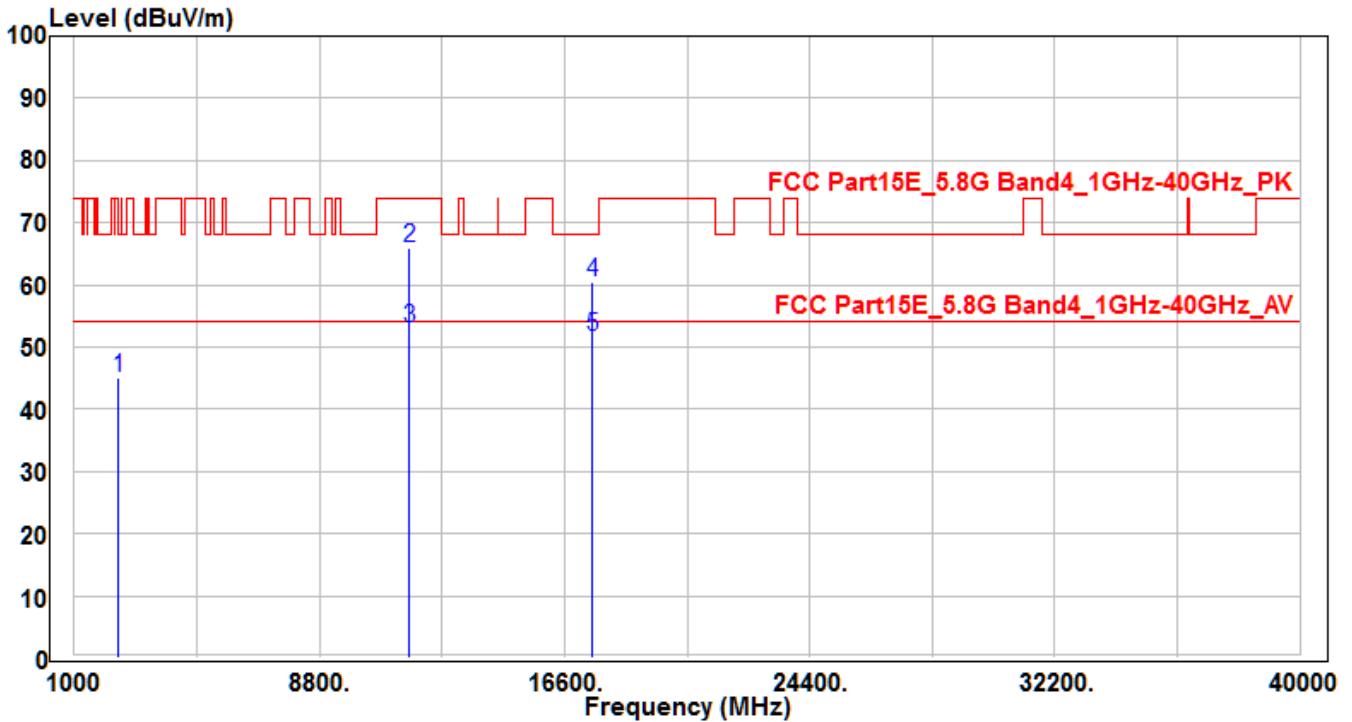

No	Frequency (MHz)	Reading (dBuV)	C.F (dB)	Measurement (dBuV/m)	Margin (dB)	Limit (dBuV)	Height (cm)	Angle (deg)	Remark (QP/PK/AV)	
1	2395.76	47.73	-2.58	45.15	-23.05	68.2	150	400	Peak	
2	*	11650	47.6	18.42	66.02	-7.98	74	150	75	Peak
3	*	11650	34.5	18.42	52.92	-1.08	54	150	75	Average
4		17475	30.15	30.18	60.33	-7.87	68.2	150	400	Peak
5		17475	21.39	30.18	51.57	-2.43	54	150	400	Average

Note: The EUT Power by Notebook PC

- "*" means the worst value in this measurement data.
- Measure Level (dBuV/m) = Reading Level (dBuV) + Factor (dB)
- C.F Factor (dB) = Cable Loss (dB) + Antenna Factor (dB/m) - Preamplifier(dB).
- The emission levels of other frequencies are very lower than the limit and not show in test report.

EUT	Wireless module	Test Date	2019/6/12
Factor	BBHA 9120D & BBHA 9170	Temp. / Humidity	25°C / 60%
Polarity	Vertical	Site / Engineer	AC1 / Peter
Test Mode	MODE2 -CH165	Test Voltage	AC 120V/60Hz

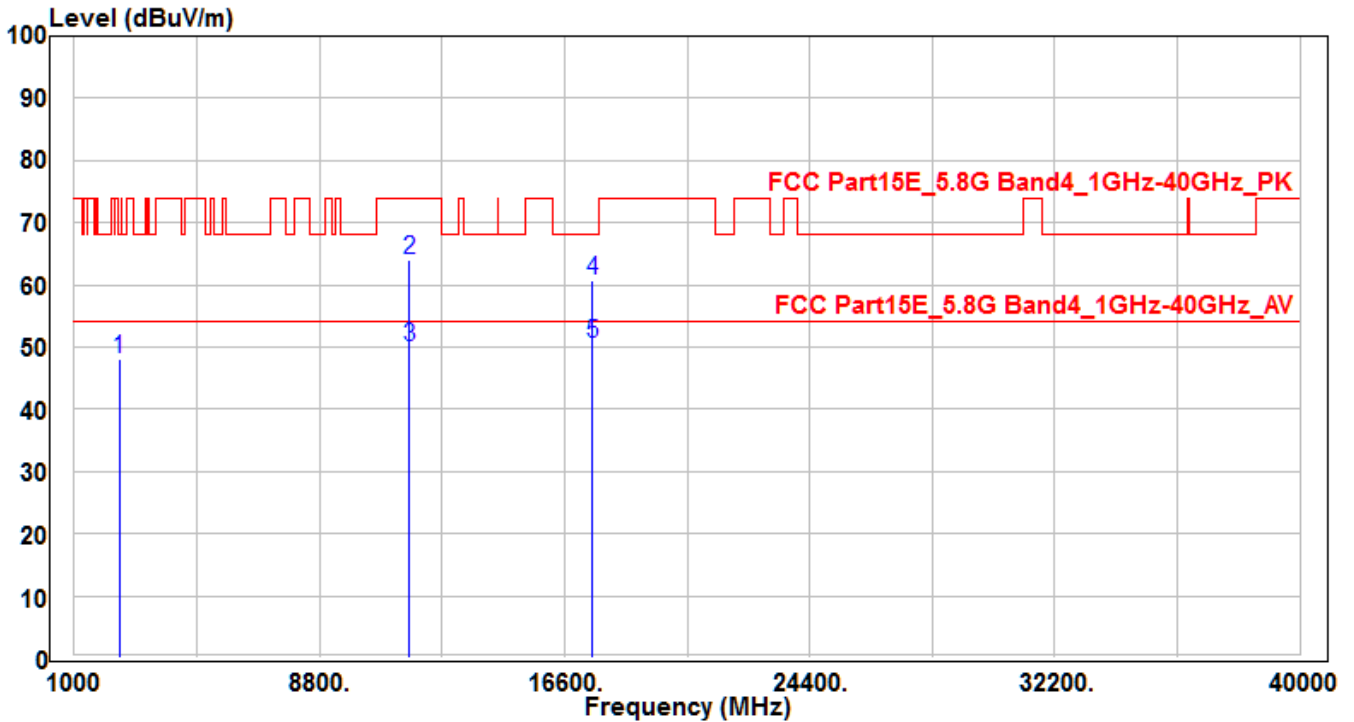

No	Frequency (MHz)	Reading (dBuV)	C.F (dB)	Measurement (dBuV/m)	Margin (dB)	Limit (dBuV)	Height (cm)	Angle (deg)	Remark (QP/PK/AV)
1	2427.16	50.63	-2.45	48.18	-20.02	68.2	150	400	Peak
2	11650	45.5	18.42	63.92	-10.08	74	150	190	Peak
3	11650	31.7	18.42	50.12	-3.88	54	150	190	Average
4	* 17475	30.41	30.18	60.59	-7.61	68.2	155	380	Peak
5	* 17475	20.37	30.18	50.55	-3.45	54	155	380	Average

Note: The EUT Power by Notebook PC

1. " * " means the worst value in this measurement data.
2. Measure Level (dBuV/m) = Reading Level (dBuV) + Factor (dB)
3. C.F Factor (dB) = Cable Loss (dB) + Antenna Factor (dB/m) - Preamplifier(dB).
4. The emission levels of other frequencies are very lower than the limit and not show in test report.

EUT	Wireless module	Test Date	2019/6/12
Factor	BBHA 9120D & BBHA 9170	Temp. / Humidity	25°C / 60%
Polarity	Horizontal	Site / Engineer	AC1 / Peter
Test Mode	MODE3 -CH38	Test Voltage	AC 120V/60Hz

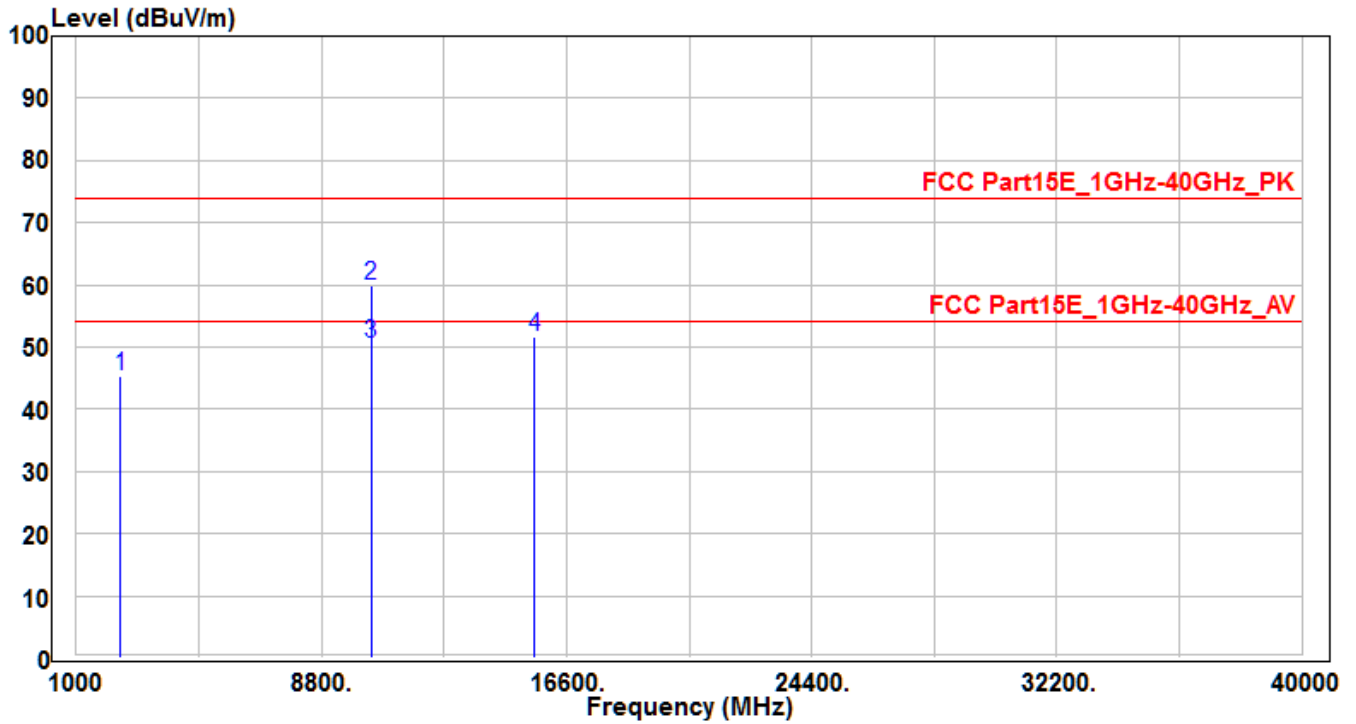

No	Frequency (MHz)	Reading (dBuV)	C.F (dB)	Measurement (dBuV/m)	Margin (dB)	Limit (dBuV)	Height (cm)	Angle (deg)	Remark (QP/PK/AV)	
1	2398.14	47.91	-2.57	45.34	-28.66	74	150	400	Peak	
2	*	10380	43.02	16.81	59.83	-14.17	74	150	135	Peak
3	*	10380	33.8	16.81	50.61	-3.39	54	150	135	Average
4		15570	30.02	21.62	51.64	-22.36	74	150	400	Peak

Note: The EUT Power by Notebook PC

1. " * " means the worst value in this measurement data.
2. Measure Level (dBuV/m) = Reading Level (dBuV) + Factor (dB)
3. C.F Factor (dB) = Cable Loss (dB) + Antenna Factor (dB/m) - Pre-amplifier(dB).
4. The emission levels of other frequencies are very lower than the limit and not show in test report.

EUT	Wireless module	Test Date	2019/6/12
Factor	BBHA 9120D & BBHA 9170	Temp. / Humidity	25°C / 60%
Polarity	Vertical	Site / Engineer	AC1 / Peter
Test Mode	MODE3 -CH38	Test Voltage	AC 120V/60Hz

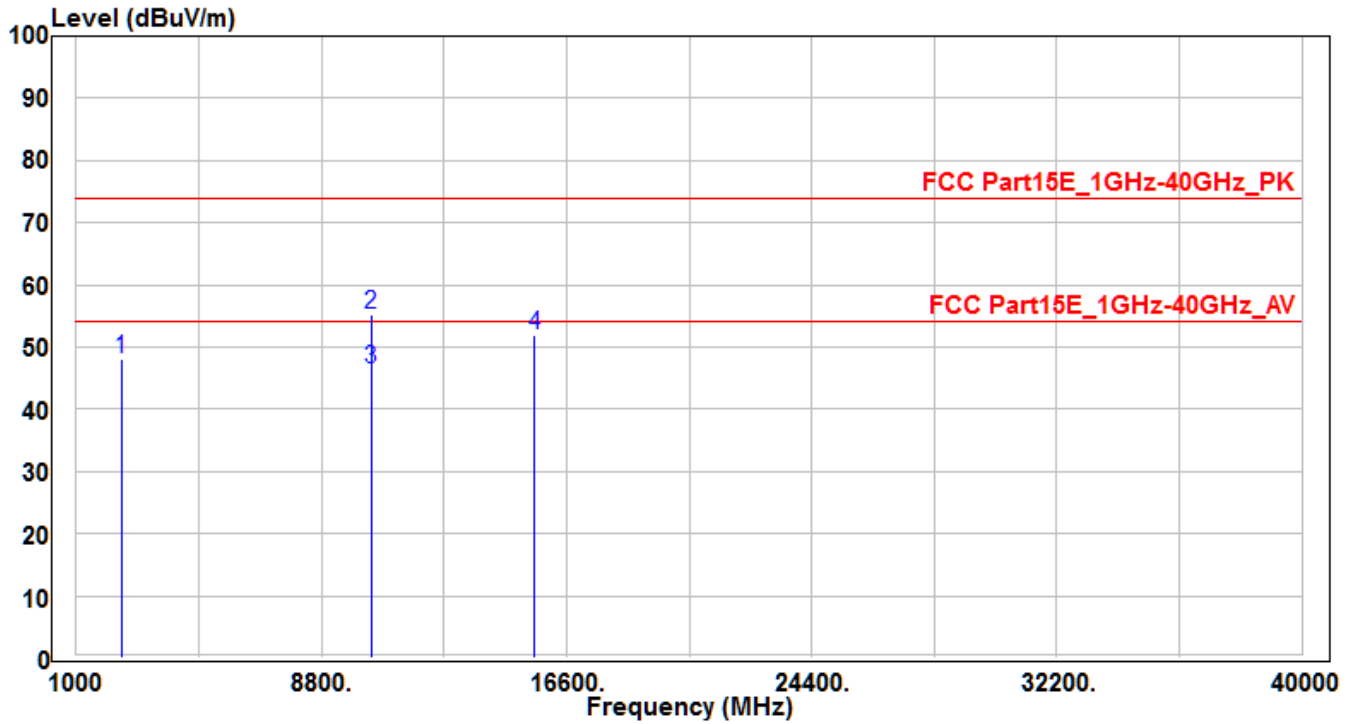

No	Frequency (MHz)	Reading (dBuV)	C.F (dB)	Measurement (dBuV/m)	Margin (dB)	Limit (dBuV)	Height (cm)	Angle (deg)	Remark (QP/PK/AV)
1	2429.62	50.63	-2.43	48.2	-25.8	74	150	400	Peak
2	* 10380	38.36	16.81	55.17	-18.83	74	150	190	Peak
3	* 10380	29.55	16.81	46.36	-7.64	54	150	190	Average
4	15570	30.25	21.62	51.87	-22.13	74	150	400	Peak

Note: The EUT Power by Notebook PC

1. " * " means the worst value in this measurement data.
2. Measure Level (dBuV/m) = Reading Level (dBuV) + Factor (dB)
3. C.F Factor (dB) = Cable Loss (dB) + Antenna Factor (dB/m) - Preamplifier(dB).
4. The emission levels of other frequencies are very lower than the limit and not show in test report.

EUT	Wireless module	Test Date	2019/6/12
Factor	BBHA 9120D & BBHA 9170	Temp. / Humidity	25°C / 60%
Polarity	Horizontal	Site / Engineer	AC1 / Peter
Test Mode	MODE3 -CH46	Test Voltage	AC 120V/60Hz

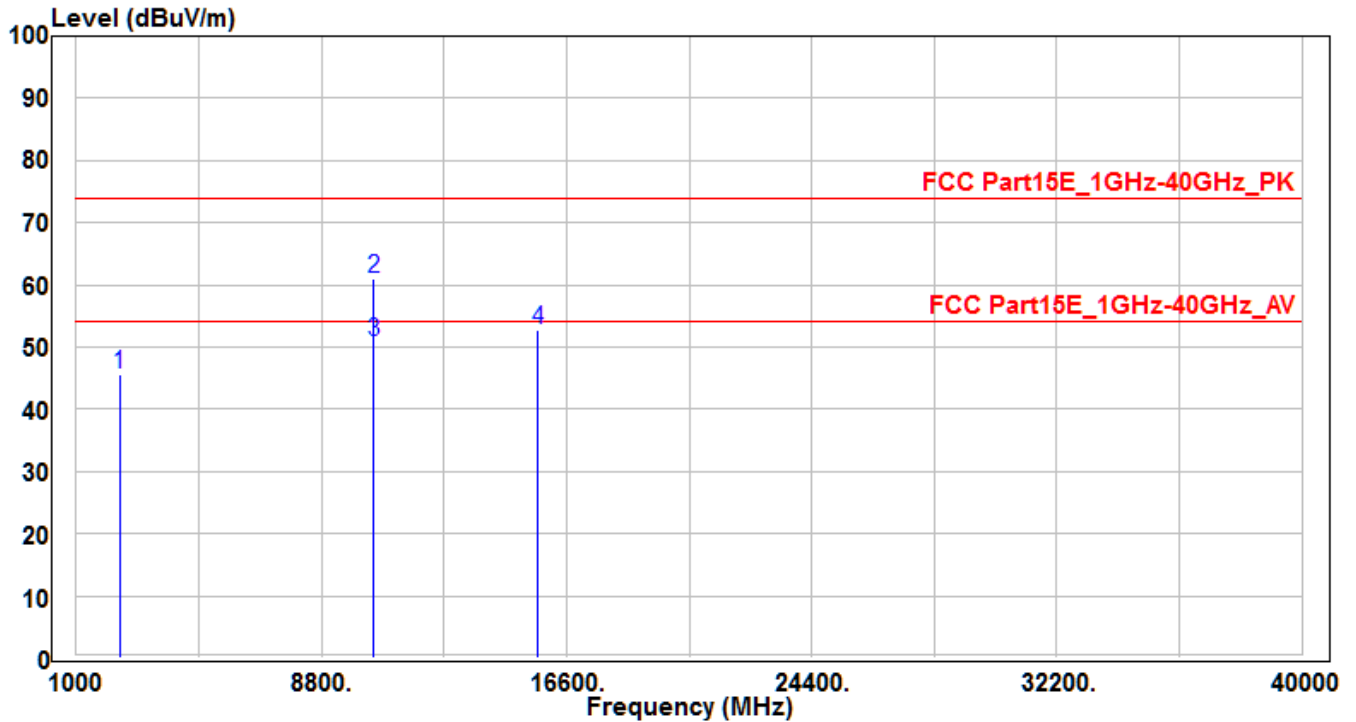

No	Frequency (MHz)	Reading (dBuV)	C.F (dB)	Measurement (dBuV/m)	Margin (dB)	Limit (dBuV)	Height (cm)	Angle (deg)	Remark (QP/PK/AV)
1	2386.34	48.18	-2.63	45.55	-28.45	74	150	400	Peak
2	* 10460	44.05	17.05	61.1	-12.9	74	150	135	Peak
3	* 10460	33.7	17.05	50.75	-3.25	54	150	135	Average
4	15690	31.22	21.43	52.65	-21.35	74	150	400	Peak

Note: The EUT Power by Notebook PC

- "*" means the worst value in this measurement data.
- Measure Level (dBuV/m) = Reading Level (dBuV) + Factor (dB)
- C.F Factor (dB) = Cable Loss (dB) + Antenna Factor (dB/m) - Pre-amplifier (dB).
- The emission levels of other frequencies are very lower than the limit and not show in test report.

EUT	Wireless module	Test Date	2019/6/12
Factor	BBHA 9120D & BBHA 9170	Temp. / Humidity	25°C / 60%
Polarity	Vertical	Site / Engineer	AC1 / Peter
Test Mode	MODE3 -CH46	Test Voltage	AC 120V/60Hz

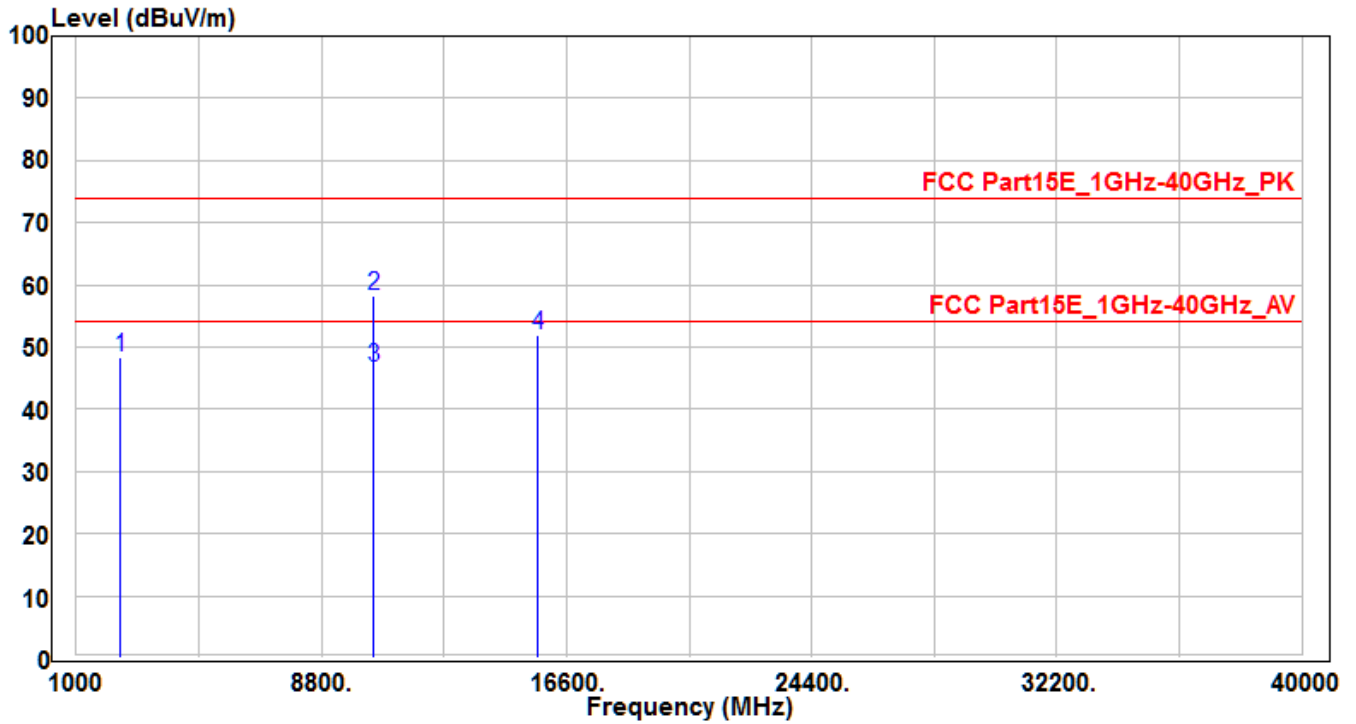

No	Frequency (MHz)	Reading (dBuV)	C.F (dB)	Measurement (dBuV/m)	Margin (dB)	Limit (dBuV)	Height (cm)	Angle (deg)	Remark (QP/PK/AV)
1	2418.58	50.79	-2.48	48.31	-25.69	74	150	400	Peak
2	*	41.18	17.05	58.23	-15.77	74	150	190	Peak
3	*	29.8	17.05	46.85	-27.15	74	150	190	Peak
4	15690	30.53	21.43	51.96	-22.04	74	150	400	Peak

Note: The EUT Power by Notebook PC

1. " * " means the worst value in this measurement data.
2. Measure Level (dBuV/m) = Reading Level (dBuV) + Factor (dB)
3. C.F Factor (dB) = Cable Loss (dB) + Antenna Factor (dB/m) - Preamplifier(dB).
4. The emission levels of other frequencies are very lower than the limit and not show in test report.

EUT	Wireless module	Test Date	2019/6/12
Factor	BBHA 9120D & BBHA 9170	Temp. / Humidity	25°C / 60%
Polarity	Horizontal	Site / Engineer	AC1 / Peter
Test Mode	MODE3 -CH151	Test Voltage	AC 120V/60Hz

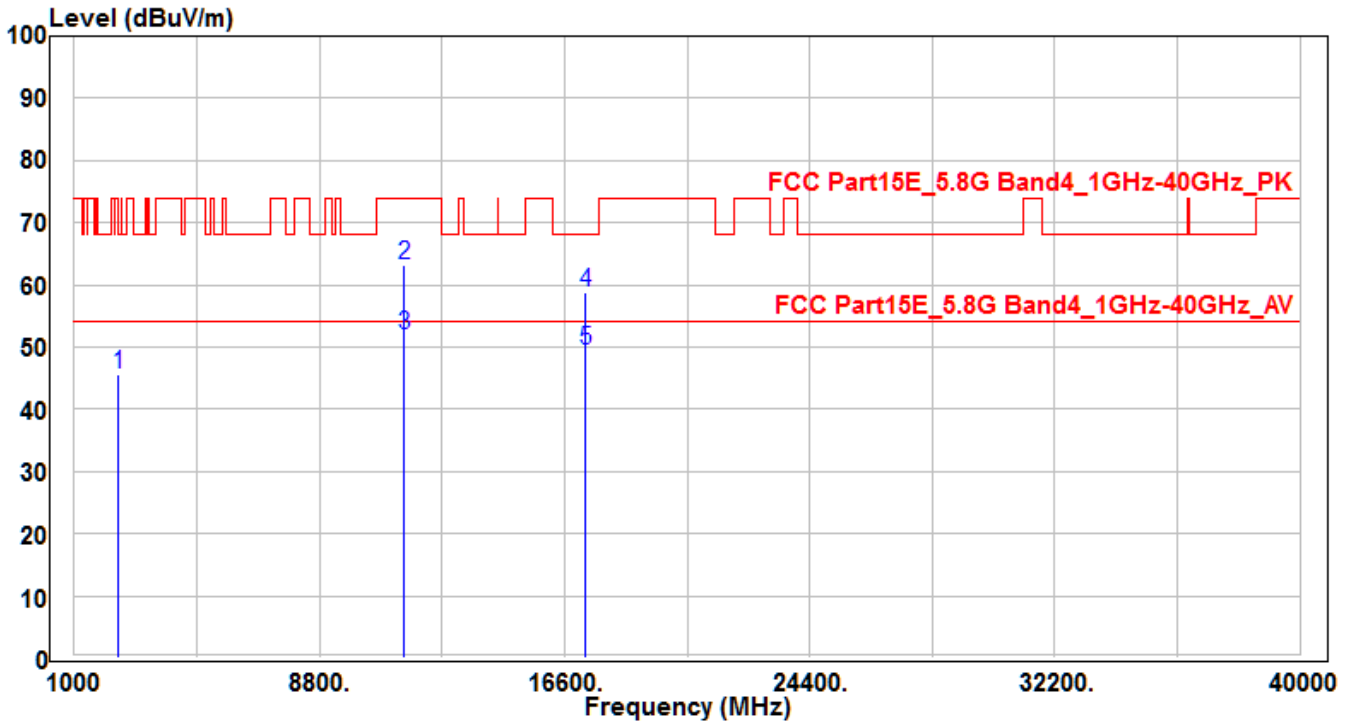

No	Frequency (MHz)	Reading (dBuV)	C.F (dB)	Measurement (dBuV/m)	Margin (dB)	Limit (dBuV)	Height (cm)	Angle (deg)	Remark (QP/PK/AV)	
1	2399.26	48.19	-2.56	45.63	-22.57	68.2	150	400	Peak	
2	*	11510	44.56	18.55	63.11	-10.89	74	150	75	Peak
3	*	11510	33.49	18.55	52.04	-1.96	54	150	75	Average
4		17265	30.69	28.12	58.81	-9.39	68.2	150	400	Peak
5		17265	21.23	28.12	49.35	-4.65	54	150	400	Average

Note: The EUT Power by Notebook PC

- "*" means the worst value in this measurement data.
- Measure Level (dBuV/m) = Reading Level (dBuV) + Factor (dB)
- C.F Factor (dB) = Cable Loss (dB) + Antenna Factor (dB/m) - Preamplifier(dB).
- The emission levels of other frequencies are very lower than the limit and not show in test report.

EUT	Wireless module	Test Date	2019/6/12
Factor	BBHA 9120D & BBHA 9170	Temp. / Humidity	25°C / 60%
Polarity	Vertical	Site / Engineer	AC1 / Peter
Test Mode	MODE3 -CH151	Test Voltage	AC 120V/60Hz

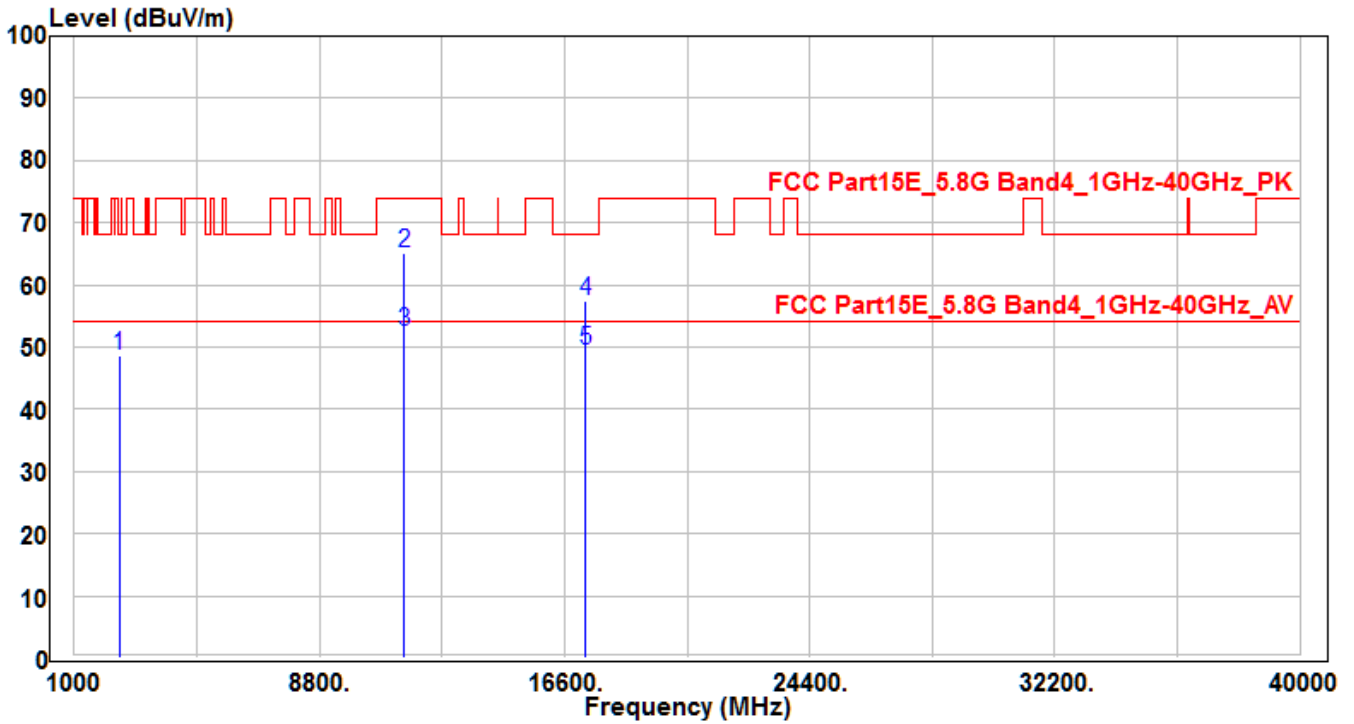

No	Frequency (MHz)	Reading (dBuV)	C.F (dB)	Measurement (dBuV/m)	Margin (dB)	Limit (dBuV)	Height (cm)	Angle (deg)	Remark (QP/PK/AV)
1	2428.96	51.07	-2.44	48.63	-19.57	68.2	150	400	Peak
2	*	46.68	18.55	65.23	-8.77	74	150	390	Peak
3	*	33.89	18.55	52.44	-1.56	54	150	390	Average
4	17265	29.35	28.12	57.47	-10.73	68.2	155	380	Peak
5	17265	21.33	28.12	49.45	-4.55	54	155	380	Average

Note: The EUT Power by Notebook PC

- "*" means the worst value in this measurement data.
- Measure Level (dBuV/m) = Reading Level (dBuV) + Factor (dB)
- C.F Factor (dB) = Cable Loss (dB) + Antenna Factor (dB/m) - Preamplifier(dB).
- The emission levels of other frequencies are very lower than the limit and not show in test report.

EUT	Wireless module	Test Date	2019/6/12
Factor	BBHA 9120D & BBHA 9170	Temp. / Humidity	25°C / 60%
Polarity	Horizontal	Site / Engineer	AC1 / Peter
Test Mode	MODE3 -CH159	Test Voltage	AC 120V/60Hz

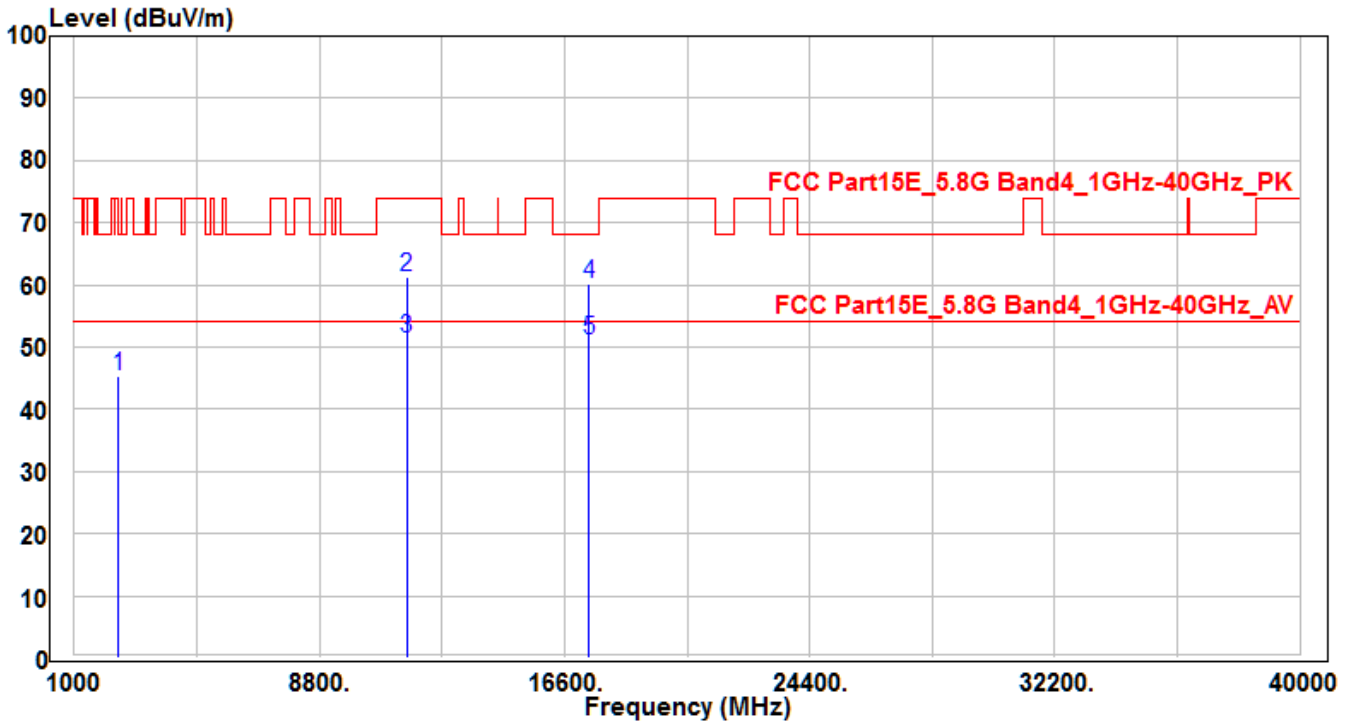

No	Frequency (MHz)	Reading (dBuV)	C.F (dB)	Measurement (dBuV/m)	Margin (dB)	Limit (dBuV)	Height (cm)	Angle (deg)	Remark (QP/PK/AV)	
1	2397.36	47.78	-2.57	45.21	-22.99	68.2	150	400	Peak	
2	*	11590	42.91	18.47	61.38	-12.62	74	150	75	Peak
3	*	11590	33	18.47	51.47	-2.53	54	150	75	Average
4		17385	30.94	29.3	60.24	-7.96	68.2	150	400	Peak
5		17385	21.81	29.3	51.11	-2.89	54	150	400	Average

Note: The EUT Power by Notebook PC

- "*" means the worst value in this measurement data.
- Measure Level (dBuV/m) = Reading Level (dBuV) + Factor (dB)
- C.F Factor (dB) = Cable Loss (dB) + Antenna Factor (dB/m) - Preamplifier(dB).
- The emission levels of other frequencies are very lower than the limit and not show in test report.

EUT	Wireless module	Test Date	2019/6/12
Factor	BBHA 9120D & BBHA 9170	Temp. / Humidity	25°C / 60%
Polarity	Vertical	Site / Engineer	AC1 / Peter
Test Mode	MODE3 -CH159	Test Voltage	AC 120V/60Hz

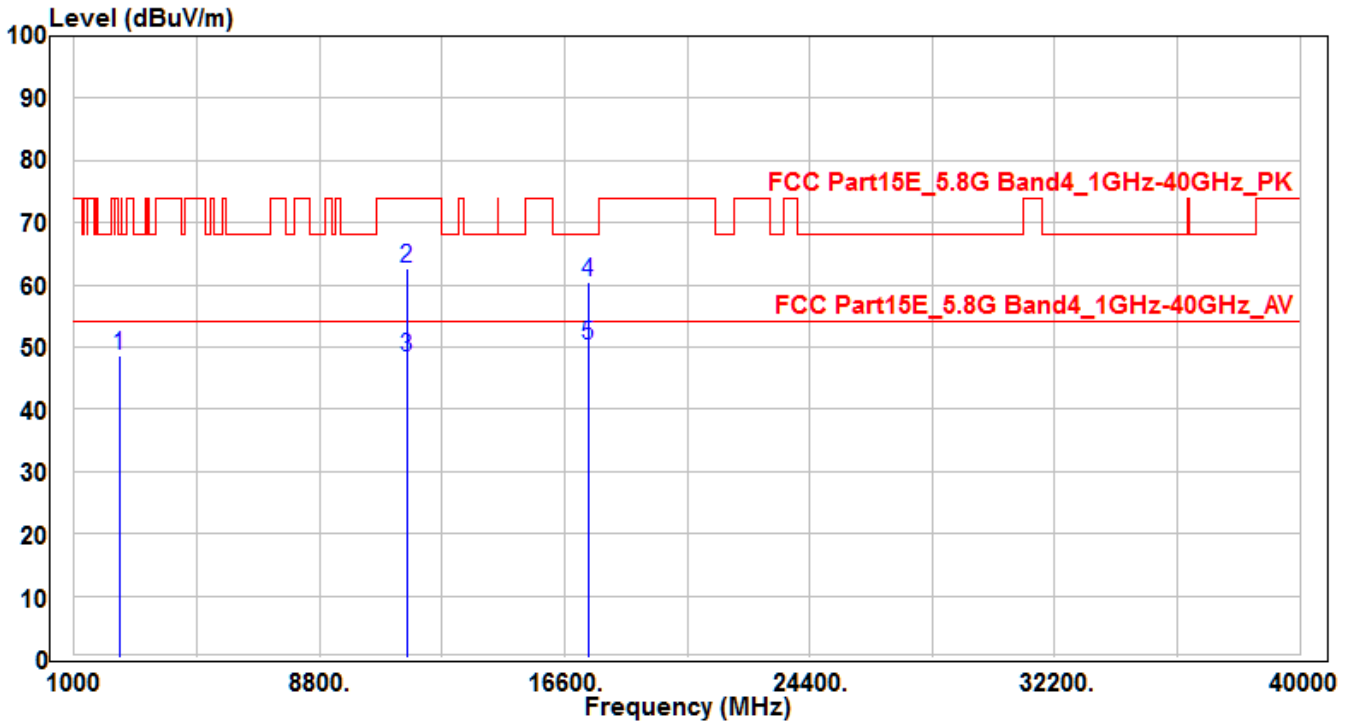

No	Frequency (MHz)	Reading (dBuV)	C.F (dB)	Measurement (dBuV/m)	Margin (dB)	Limit (dBuV)	Height (cm)	Angle (deg)	Remark (QP/PK/AV)
1	2427.57	51.21	-2.45	48.76	-19.44	68.2	150	400	Peak
2	11590	44.06	18.47	62.53	-11.47	74	150	190	Peak
3	11590	29.89	18.47	48.36	-5.64	54	150	190	Average
4	* 17355	31.4	29	60.4	-7.8	68.2	155	380	Peak
5	* 17355	21.24	29	50.24	-3.76	54	155	380	Average

Note: The EUT Power by Notebook PC

1. " * " means the worst value in this measurement data.
2. Measure Level (dBuV/m) = Reading Level (dBuV) + Factor (dB)
3. C.F Factor (dB) = Cable Loss (dB) + Antenna Factor (dB/m) - Preamplifier(dB).
4. The emission levels of other frequencies are very lower than the limit and not show in test report.

7.8. Radiated Restricted Band Edge Measurement

7.8.1. Test Limit

For 15.205 requirement/ For IC RSS-Gen requirement:

Radiated emissions which fall in the restricted bands, as defined in Section 15.205(a) of FCC part 15, must also comply with the radiated emission limits specified in Section 15.209(a)/ IC RSS-Gen Table 7..

Frequency (MHz)	Frequency (MHz)	Frequency (MHz)	Frequency (GHz)
0.090 - 0.110	16.42 - 16.423	399.9 - 410	4.5 - 5.15
¹ 0.495 - 0.505	16.69475 - 16.69525	608 - 614	5.35 - 5.46
2.1735 - 2.1905	16.80425 - 16.80475	960 - 1240	7.25 - 7.75
4.125 - 4.128	25.5 - 25.67	1300 - 1427	8.25 - 8.5
4.17725 - 4.17775	37.5 - 38.25	1435 - 1626.5	9.0 - 9.2
4.20725 - 4.20775	73 - 74.6	1645.5 - 1646.5	9.3 - 9.5
6.215 - 6.218	74.8 - 75.2	1660 - 1710	10.6 - 12.7
6.26775 - 6.26825	108 - 121.94	1718.8 - 1722.2	13.25 - 13.4
6.31175 - 6.31225	123 - 138	2200 - 2300	14.47 - 14.5
8.291 - 8.294	149.9 - 150.05	2310 - 2390	15.35 - 16.2
8.362 - 8.366	156.52475 - 156.525	2483.5 - 2500	17.7 - 21.4
8.37625 - 8.38675	156.7 - 156.9	2690 - 2900	22.01 - 23.12
8.41425 - 8.41475	162.0125 - 167.17	3260 - 3267	23.6 - 24.0
12.29 - 12.293	167.72 - 173.2	3332 - 3339	31.2 - 31.8
12.51975 - 12.52025	240 - 285	3345.8 - 3358	36.43 - 36.5
12.57675 - 12.57725	322 - 335.4	3600 - 4400	(²)
13.36 - 13.41	--	--	--

For 15.407(b) requirement:

For transmitters operating in the 5.15-5.25 GHz band: All emissions outside of the 5.15-5.35 GHz band shall not exceed an e.i.r.p. of -27 dBm/MHz.

For transmitters operating in the 5.25-5.35 GHz band: All emissions outside of the 5.15-5.35 GHz band shall not exceed an e.i.r.p. of -27 dBm/MHz.

For transmitters operating in the 5.47-5.725 GHz band: All emissions outside of the 5.47-5.725 GHz band shall not exceed an e.i.r.p. of -27 dBm/MHz.

For FCC transmitters operating in the 5.725-5.85 GHz band: All emissions shall be limited to a level of -27 dBm/MHz at 75 MHz or more above or below the band edge increasing linearly to 10 dBm/MHz at 25 MHz above or below the band edge, and from 25 MHz above or below the band edge increasing linearly to a level of 15.6 dBm/MHz at 5 MHz above or below the band edge, and from 5 MHz above or below the band edge increasing linearly to a level of 27 dBm/MHz at the band edge.

For IC transmitters operating in the 5.725-5.85 GHz band: All emissions within the frequency range from the band edge to 10 MHz above or below the band edge shall not exceed an e.i.r.p. of -17 dBm/MHz; for frequencies 10 MHz or greater above or below the band edge, emissions shall not exceed an e.i.r.p. of -27 dBm/MHz.

Refer to KDB 789033 D02v02r01 G)2)c), as specified in § 15.407(b), emissions above 1000 MHz that are outside of the restricted bands are subject to a maximum emission limit of -27 dBm/MHz (or -17 dBm/MHz as specified in § 15.407(b)(4)). However, an out-of-band emission that complies with both the peak and average limits of § 15.209 is not required to satisfy the -27 dBm/MHz or -17 dBm/MHz maximum emission limit.

All out of band emissions appearing in a restricted band as specified in Section 15.205 of the Title 47 CFR must not exceed the limits shown in Table per Section 15.209.

Radiated emission limits; general requirements.

FCC Part 15 Subpart C Paragraph 15.209/ IC RSS-Gen Table 7.		
Frequency [MHz]	Field Strength [V/m]	Measured Distance [Meters]
0.009 ~ 0.490	2400/F (kHz)	300
0.490 ~ 1.705	24000/F (kHz)	30
1.705 ~ 30	30	30
30 ~ 88	100	3
88 ~ 216	150	3
216 ~ 960	200	3
Above 960	500	3

7.8.2. Test Result

EUT	Wireless module	Test Date	2019/6/4
Factor	BBHA 9120D	Temp. / Humidity	21°C / 57%
Polarity	Horizontal	Site / Engineer	AC1 / Peter
Test Mode	MODE1-CH36	Test Voltage	AC 120V/60Hz

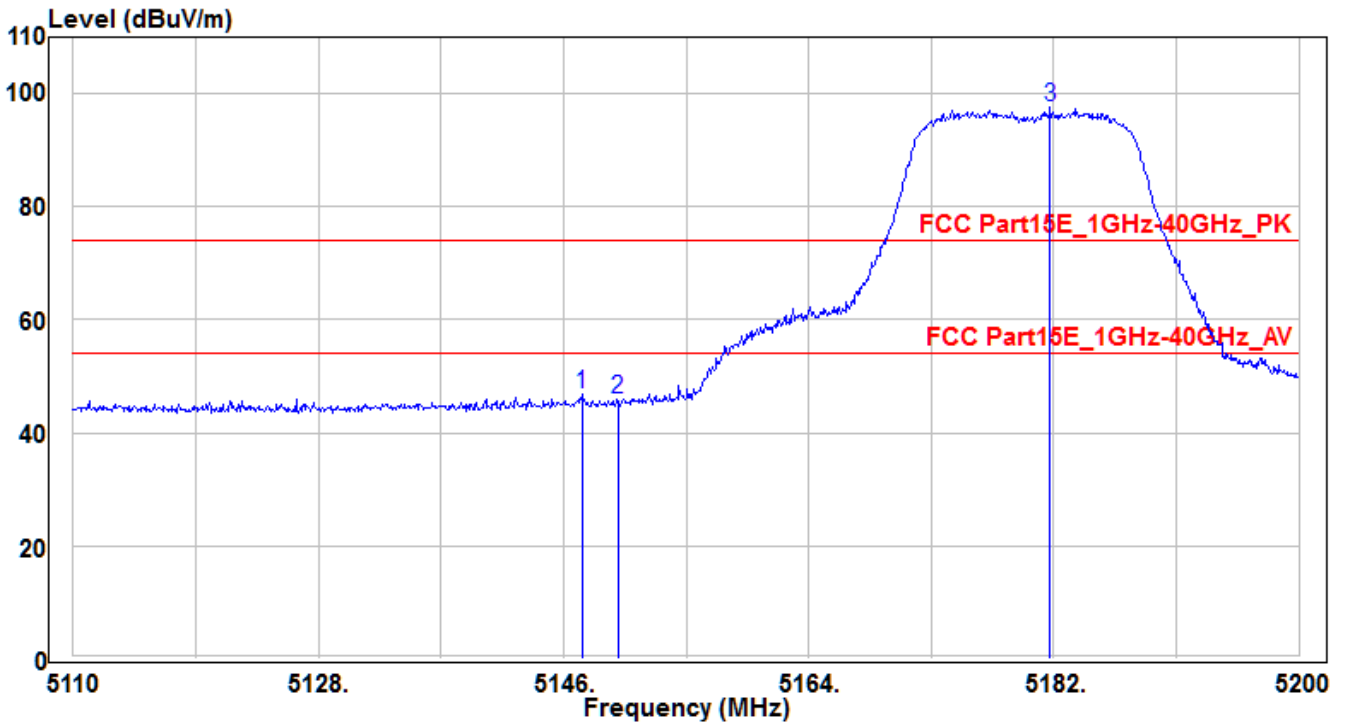

No	Frequency (MHz)	Reading (dBuV)	C.F (dB)	Measurement (dBuV/m)	Margin (dB)	Limit (dBuV)	Height (cm)	Angle (deg)	Remark (QP/PK/AV)
1	* 5147.35	42.85	3.9	46.75	-27.25	74	150	165	Peak
2	5150	42.03	3.91	45.94	-28.06	74	150	165	Peak
3	5181.73	93.57	3.94	97.51	23.51	74	150	165	Peak

Note: The EUT Power by Notebook PC

- "*" means the worst value in this measurement data.
- C.F (Correction Factor) = Antenna Factor (dB)+ Cable Loss (dB) – Preamplifier(dB)
- Measurement (dBuV/m) = Reading(dBuV) + C.F (Correction Factor)

EUT	Wireless module	Test Date	2019/6/4
Factor	BBHA 9120D	Temp. / Humidity	21°C / 57%
Polarity	Vertical	Site / Engineer	AC1 / Peter
Test Mode	MODE1-CH36	Test Voltage	AC 120V/60Hz

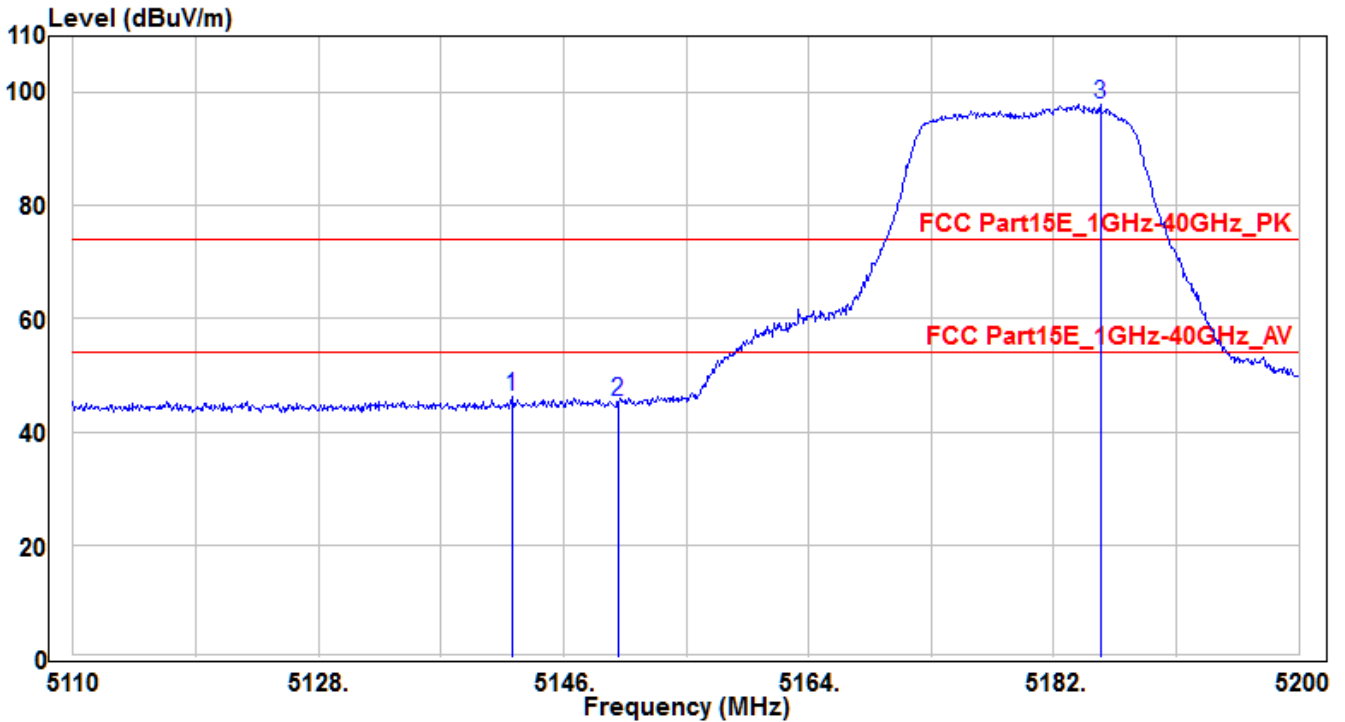

No	Frequency (MHz)	Reading (dBuV)	C.F (dB)	Measurement (dBuV/m)	Margin (dB)	Limit (dBuV)	Height (cm)	Angle (deg)	Remark (QP/PK/AV)	
1	*	5142.22	42.31	3.9	46.21	-27.79	74	150	90	Peak
2		5150	41.42	3.91	45.33	-28.67	74	150	90	Peak
3		5185.42	93.94	3.95	97.89	23.89	74	150	90	Peak

Note: The EUT Power by Notebook PC

1. " * " means the worst value in this measurement data.
2. C.F (Correction Factor) = Antenna Factor (dB)+ Cable Loss (dB) – Preamplifier(dB)
3. Measurement (dBuV/m) = Reading(dBuV) + C.F (Correction Factor)

EUT	Wireless module	Test Date	2019/6/4
Factor	BBHA 9120D	Temp. / Humidity	21°C / 57%
Polarity	Horizontal	Site / Engineer	AC1 / Peter
Test Mode	MODE1-CH149	Test Voltage	AC 120V/60Hz

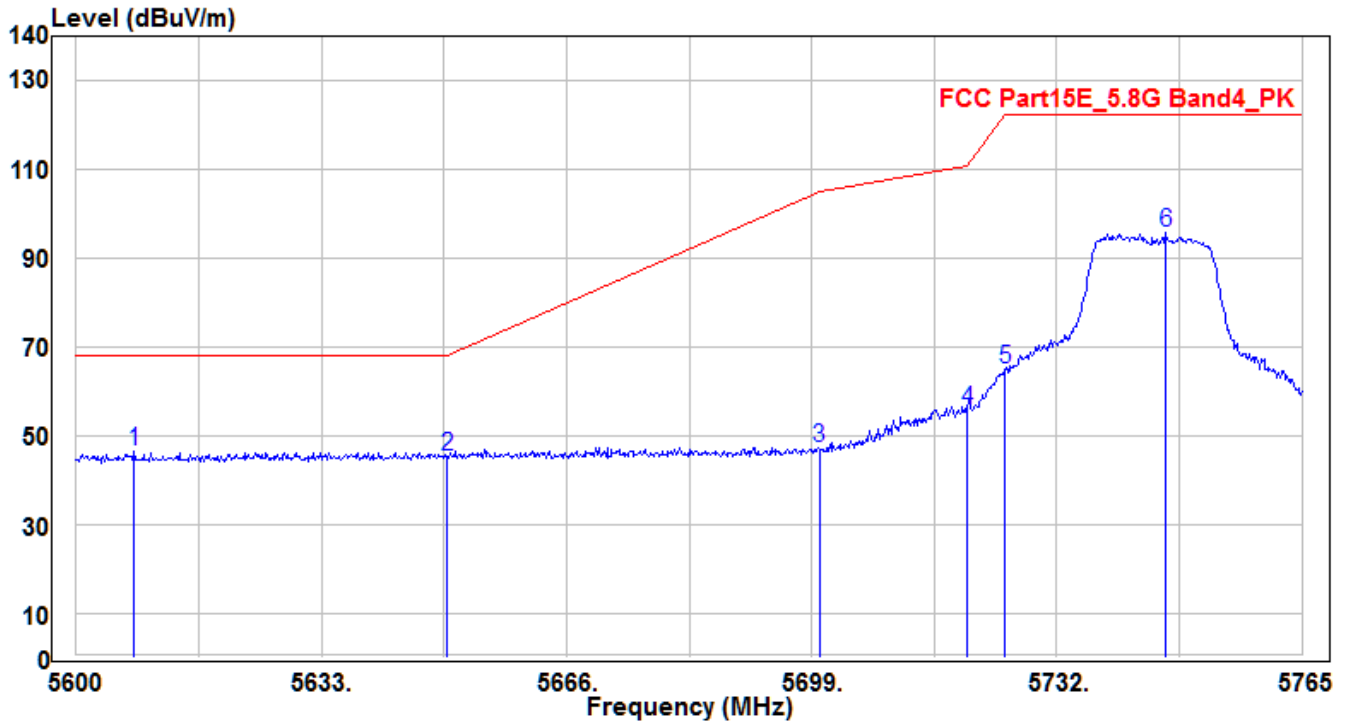

No	Frequency (MHz)	Reading (dBUV)	C.F (dB)	Measurement (dBUV/m)	Margin (dB)	Limit (dBUV)	Height (cm)	Angle (deg)	Remark (QP/PK/AV)
1	* 5607.755	41.81	4.62	46.43	-21.77	68.2	170	155	Peak
2	5650	40.55	4.76	45.31	-22.89	68.2	170	155	Peak
3	5700	42.24	4.92	47.16	-58.04	105.2	170	155	Peak
4	5720	50.72	4.97	55.69	-55.11	110.8	170	155	Peak
5	5725	59.98	5	64.98	-57.22	122.2	170	155	Peak
6	5746.685	90.62	5.08	95.7	-26.5	122.2	170	155	Peak

Note: The EUT Power by Notebook PC

1. " * " means the worst value in this measurement data.
2. C.F (Correction Factor) = Antenna Factor (dB)+ Cable Loss (dB) – Preamplifier(dB)
3. Measurement (dBUV/m) = Reading(dBUV) + C.F (Correction Factor)

EUT	Wireless module	Test Date	2019/6/4
Factor	BBHA 9120D	Temp. / Humidity	21°C / 57%
Polarity	Vertical	Site / Engineer	AC1 / Peter
Test Mode	MODE1-CH149	Test Voltage	AC 120V/60Hz

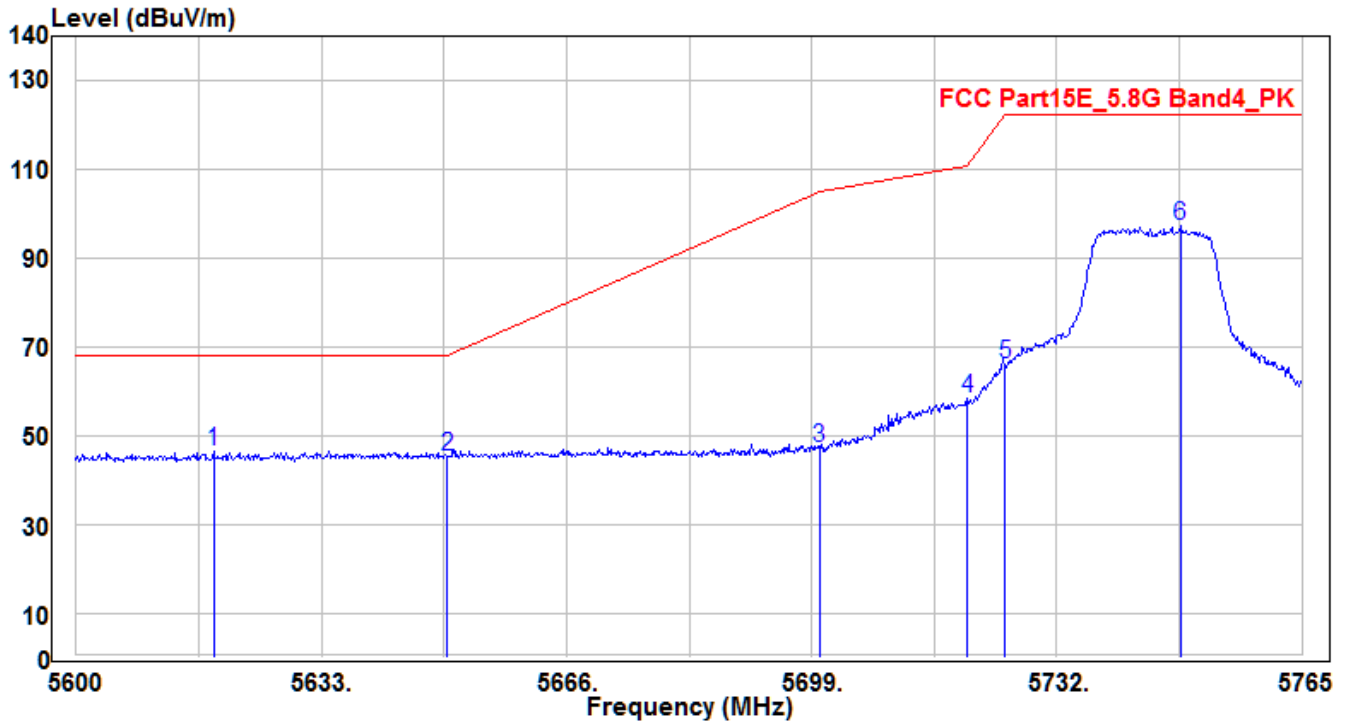

No	Frequency (MHz)	Reading (dBuV)	C.F (dB)	Measurement (dBuV/m)	Margin (dB)	Limit (dBuV)	Height (cm)	Angle (deg)	Remark (QP/PK/AV)
1	* 5618.48	41.88	4.65	46.53	-21.67	68.2	105	110	Peak
2	5650	40.81	4.76	45.57	-22.63	68.2	105	110	Peak
3	5700	42.33	4.92	47.25	-57.95	105.2	105	110	Peak
4	5720	53.41	4.97	58.38	-52.42	110.8	105	110	Peak
5	5725	61.26	5	66.26	-55.94	122.2	105	110	Peak
6	5748.665	92.18	5.08	97.26	-24.94	122.2	105	110	Peak

Note: The EUT Power by Notebook PC

- "*" means the worst value in this measurement data.
- C.F (Correction Factor) = Antenna Factor (dB)+ Cable Loss (dB) – Preamplifier(dB)
- Measurement (dBuV/m) = Reading(dBuV) + C.F (Correction Factor)

EUT	Wireless module	Test Date	2019/6/4
Factor	BBHA 9120D	Temp. / Humidity	21°C / 57%
Polarity	Horizontal	Site / Engineer	AC1 / Peter
Test Mode	MODE1-CH165	Test Voltage	AC 120V/60Hz

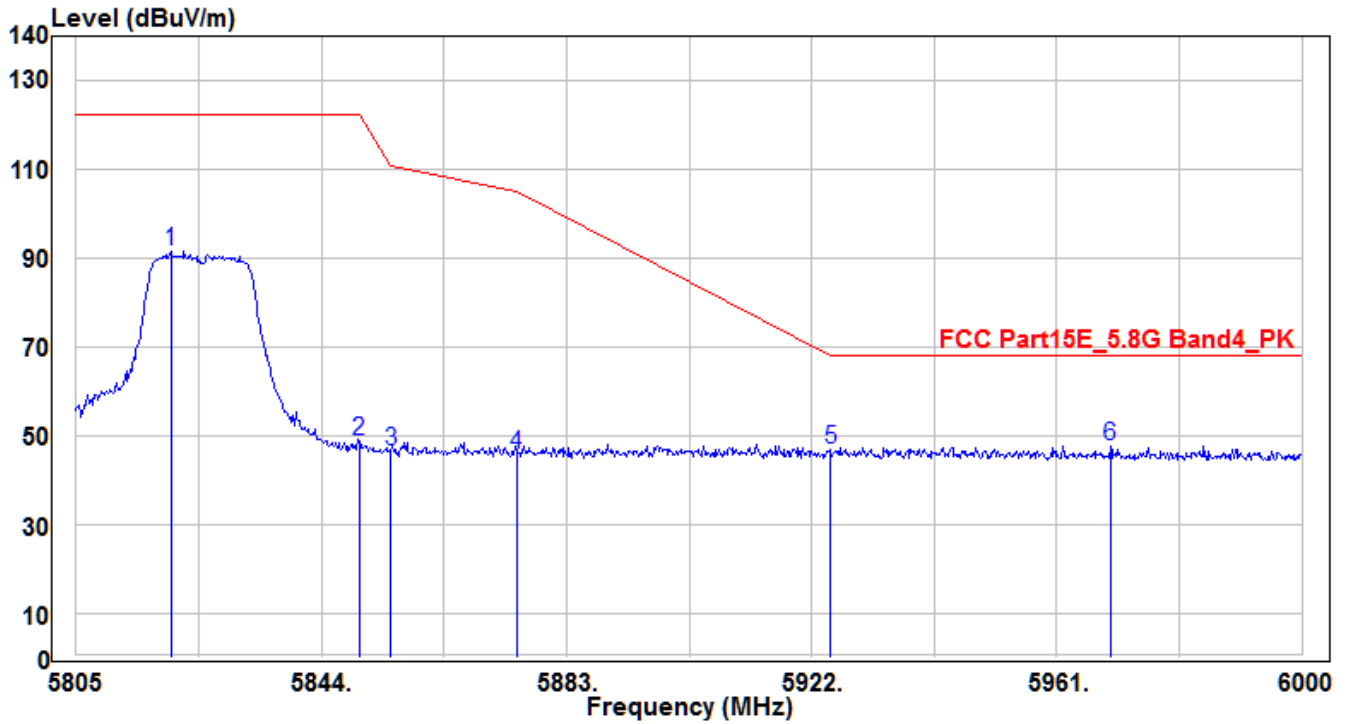

No	Frequency (MHz)	Reading (dBuV)	C.F (dB)	Measurement (dBuV/m)	Margin (dB)	Limit (dBuV)	Height (cm)	Angle (deg)	Remark (QP/PK/AV)
1	5820.015	86.42	5.3	91.72	-30.48	122.2	170	155	Peak
2	5850	43.6	5.4	49	-73.2	122.2	170	155	Peak
3	5855	41.28	5.43	46.71	-64.09	110.8	170	155	Peak
4	5875	40.46	5.49	45.95	-59.25	105.2	170	155	Peak
5	5925	41.1	5.65	46.75	-21.45	68.2	170	155	Peak
6	* 5969.58	41.88	5.78	47.66	-20.54	68.2	170	155	Peak

Note: The EUT Power by Notebook PC

1. " * " means the worst value in this measurement data.
2. C.F (Correction Factor) = Antenna Factor (dB)+ Cable Loss (dB) – Preamplifier(dB)
3. Measurement (dBuV/m) = Reading(dBuV) + C.F (Correction Factor)

EUT	Wireless module	Test Date	2019/6/4
Factor	BBHA 9120D	Temp. / Humidity	21°C / 57%
Polarity	Vertical	Site / Engineer	AC1 / Peter
Test Mode	MODE1-CH165	Test Voltage	AC 120V/60Hz

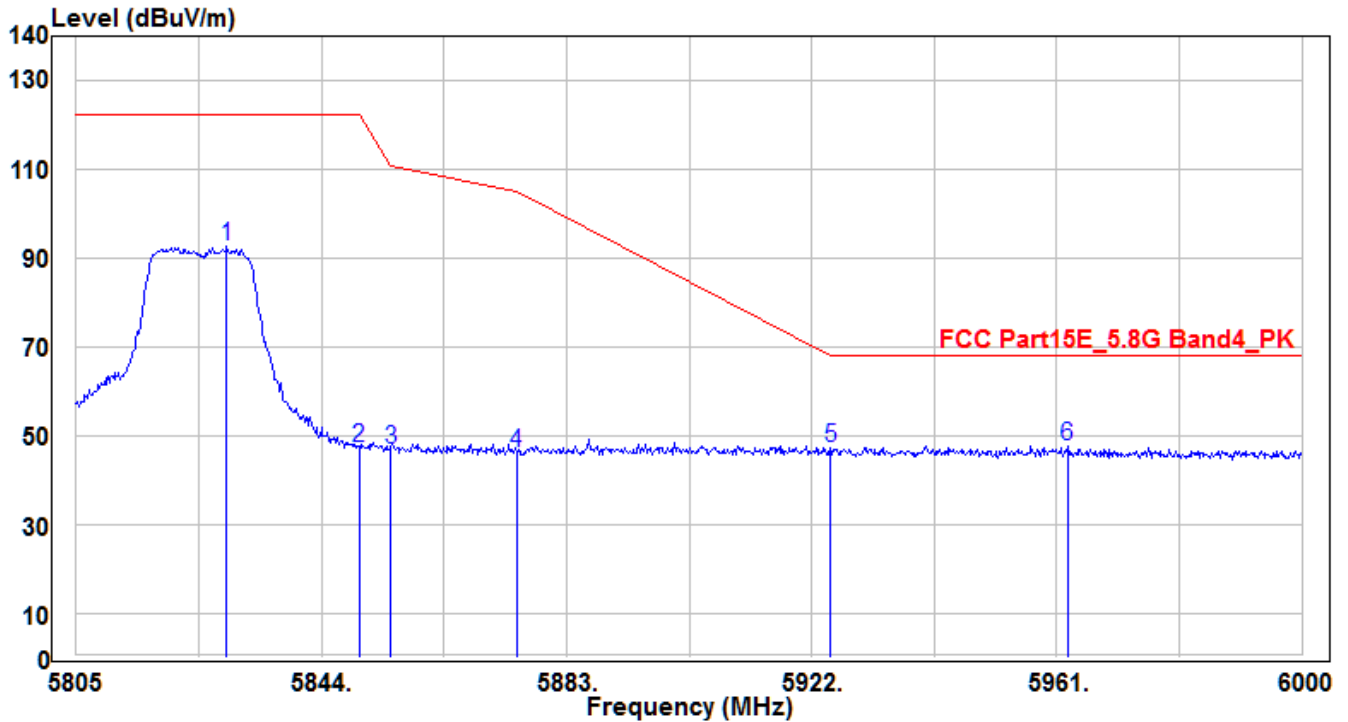

No	Frequency (MHz)	Reading (dBUV)	C.F (dB)	Measurement (dBUV/m)	Margin (dB)	Limit (dBUV)	Height (cm)	Angle (deg)	Remark (QP/PK/AV)
1	5828.985	87.22	5.33	92.55	-29.65	122.2	105	110	Peak
2	5850	42.08	5.4	47.48	-74.72	122.2	105	110	Peak
3	5855	41.52	5.43	46.95	-63.85	110.8	105	110	Peak
4	5875	40.84	5.49	46.33	-58.87	105.2	105	110	Peak
5	5925	41.76	5.65	47.41	-20.79	68.2	105	110	Peak
6	* 5962.755	41.95	5.78	47.73	-20.47	68.2	105	110	Peak

Note: The EUT Power by Notebook PC

1. " * " means the worst value in this measurement data.
2. C.F (Correction Factor) = Antenna Factor (dB)+ Cable Loss (dB) – Preamplifier(dB)
3. Measurement (dBUV/m) = Reading(dBUV) + C.F (Correction Factor)

EUT	Wireless module	Test Date	2019/6/4
Factor	BBHA 9120D	Temp. / Humidity	21°C / 57%
Polarity	Horizontal	Site / Engineer	AC1 / Peter
Test Mode	MODE2-CH36	Test Voltage	AC 120V/60Hz

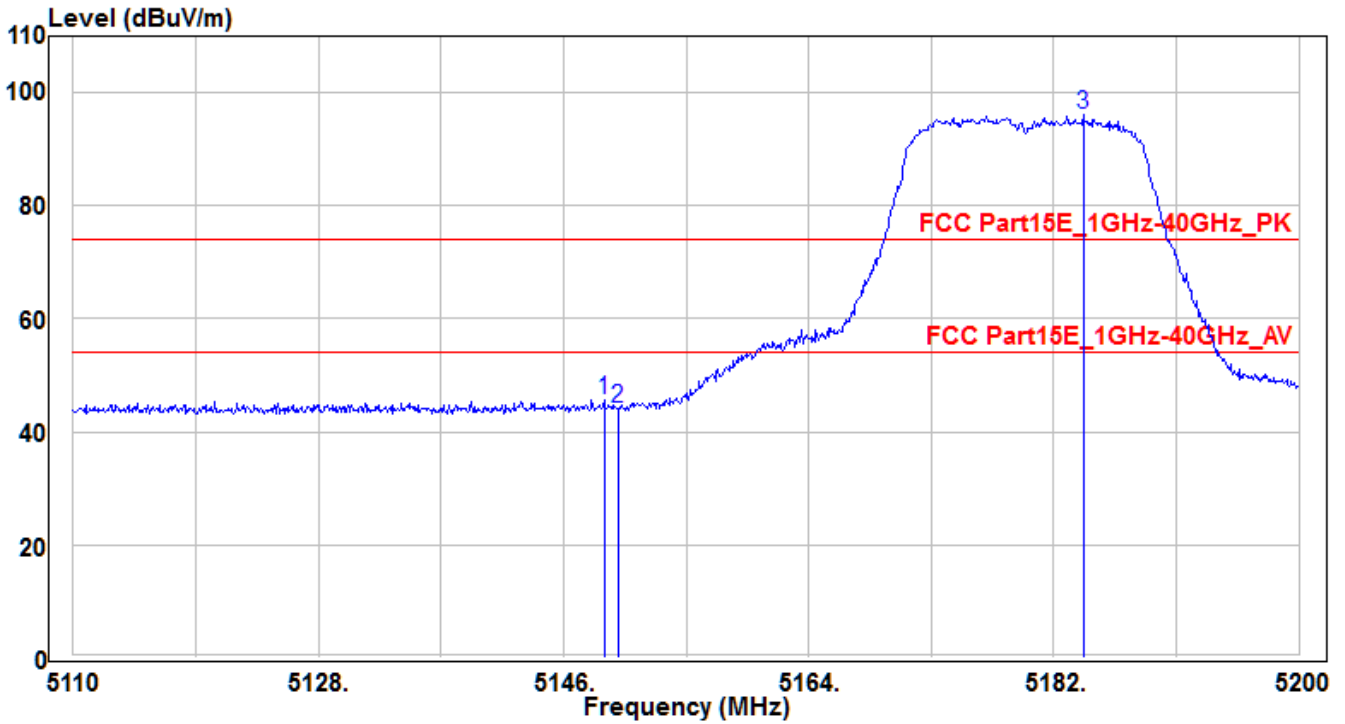

No	Frequency (MHz)	Reading (dBuV)	C.F (dB)	Measurement (dBuV/m)	Margin (dB)	Limit (dBuV)	Height (cm)	Angle (deg)	Remark (QP/PK/AV)	
1	*	5148.97	41.8	3.91	45.71	-28.29	74	150	165	Peak
2		5150	40.15	3.91	44.06	-29.94	74	150	165	Peak
3		5184.16	92.09	3.94	96.03	22.03	74	150	165	Peak

Note: The EUT Power by Notebook PC

1. " * " means the worst value in this measurement data.
2. C.F (Correction Factor) = Antenna Factor (dB)+ Cable Loss (dB) – Preamplifier(dB)
3. Measurement (dBuV/m) = Reading(dBuV) + C.F (Correction Factor)

EUT	Wireless module	Test Date	2019/6/4
Factor	BBHA 9120D	Temp. / Humidity	21°C / 57%
Polarity	Vertical	Site / Engineer	AC1 / Peter
Test Mode	MODE2-CH36	Test Voltage	AC 120V/60Hz

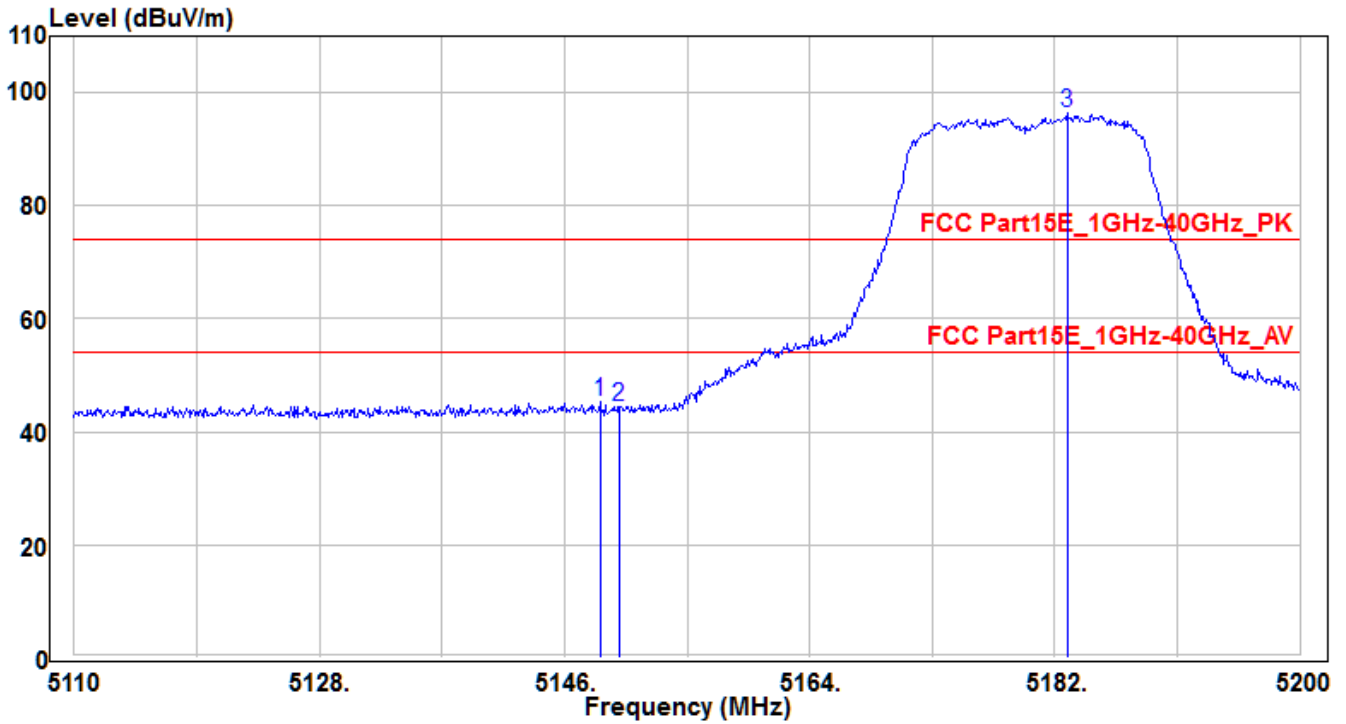

No	Frequency (MHz)	Reading (dBuV)	C.F (dB)	Measurement (dBuV/m)	Margin (dB)	Limit (dBuV)	Height (cm)	Angle (deg)	Remark (QP/PK/AV)	
1	*	5148.61	41.31	3.9	45.21	-28.79	74	150	90	Peak
2		5150	40.39	3.91	44.3	-29.7	74	150	90	Peak
3		5182.9	92.5	3.94	96.44	22.44	74	150	90	Peak

Note: The EUT Power by Notebook PC

1. " * " means the worst value in this measurement data.
2. C.F (Correction Factor) = Antenna Factor (dB)+ Cable Loss (dB) – Preamplifier(dB)
3. Measurement (dBuV/m) = Reading(dBuV) + C.F (Correction Factor)

EUT	Wireless module	Test Date	2019/6/4
Factor	BBHA 9120D	Temp. / Humidity	21°C / 57%
Polarity	Horizontal	Site / Engineer	AC1 / Peter
Test Mode	MODE2-CH149	Test Voltage	AC 120V/60Hz

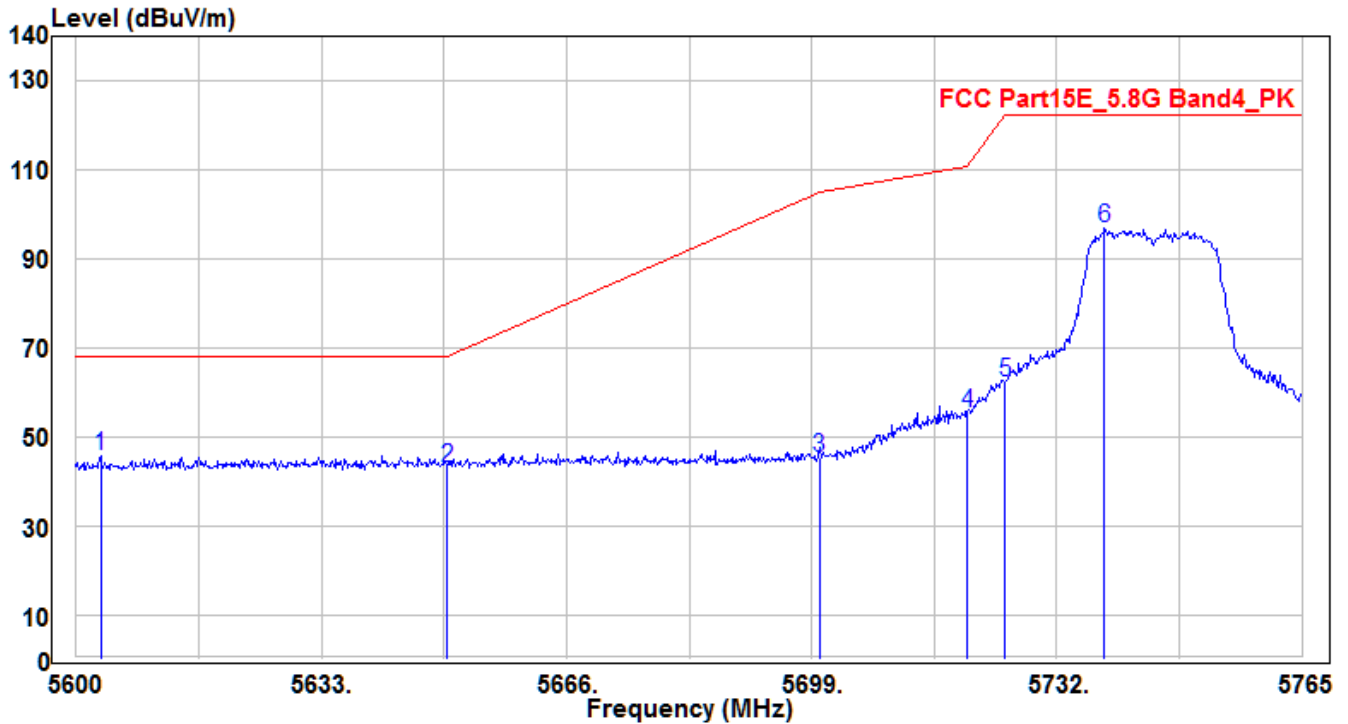

No	Frequency (MHz)	Reading (dBuV)	C.F (dB)	Measurement (dBuV/m)	Margin (dB)	Limit (dBuV)	Height (cm)	Angle (deg)	Remark (QP/PK/AV)
1	* 5603.3	41.17	4.6	45.77	-22.43	68.2	170	155	Peak
2	5650	38.44	4.76	43.2	-25	68.2	170	155	Peak
3	5700	40.37	4.92	45.29	-59.91	105.2	170	155	Peak
4	5720	50.41	4.97	55.38	-55.42	110.8	170	155	Peak
5	5725	57.18	5	62.18	-60.02	122.2	170	155	Peak
6	5738.435	91.8	5.05	96.85	-25.35	122.2	170	155	Peak

Note: The EUT Power by Notebook PC

- "*" means the worst value in this measurement data.
- C.F (Correction Factor) = Antenna Factor (dB)+ Cable Loss (dB) – Preamplifier(dB)
- Measurement (dBuV/m) = Reading(dBuV) + C.F (Correction Factor)

EUT	Wireless module	Test Date	2019/6/4
Factor	BBHA 9120D	Temp. / Humidity	21°C / 57%
Polarity	Vertical	Site / Engineer	AC1 / Peter
Test Mode	MODE2-CH149	Test Voltage	AC 120V/60Hz

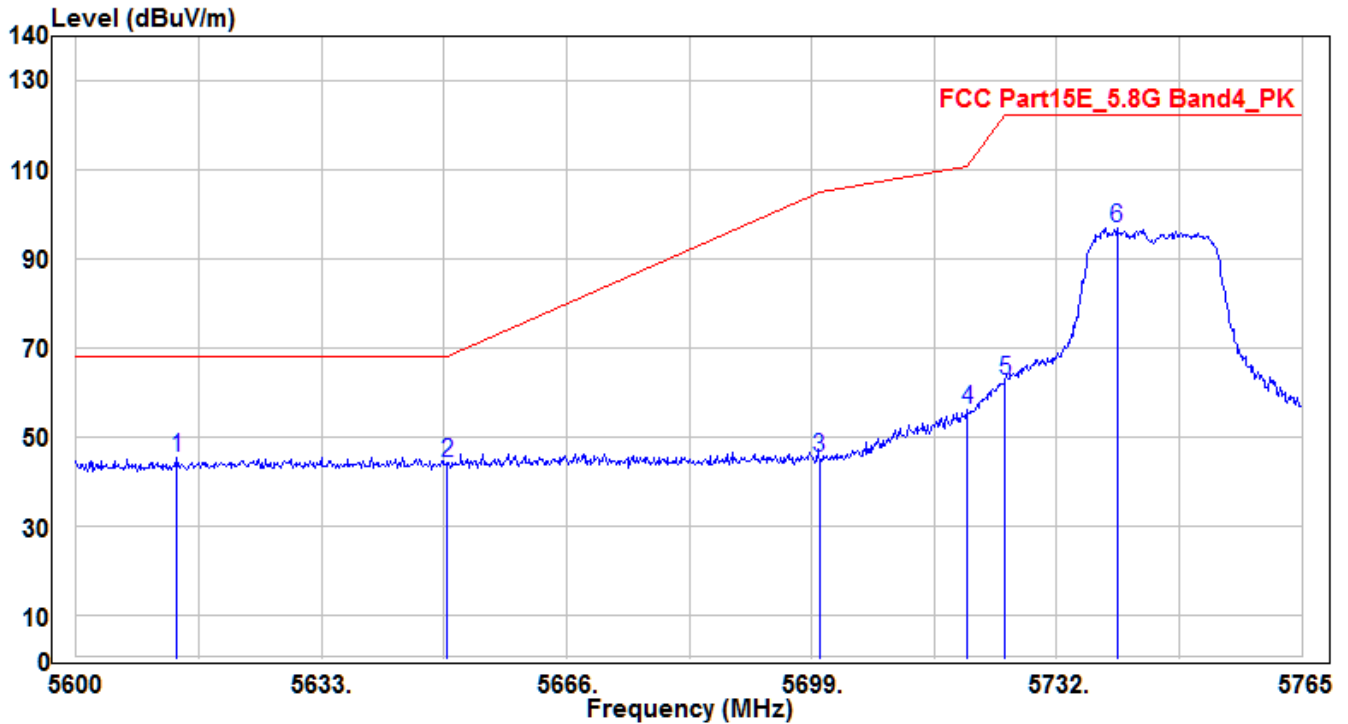

No	Frequency (MHz)	Reading (dBUV)	C.F (dB)	Measurement (dBUV/m)	Margin (dB)	Limit (dBUV)	Height (cm)	Angle (deg)	Remark (QP/PK/AV)
1	* 5613.53	40.94	4.65	45.59	-22.61	68.2	105	110	Peak
2	5650	39.45	4.76	44.21	-23.99	68.2	105	110	Peak
3	5700	40.52	4.92	45.44	-59.76	105.2	105	110	Peak
4	5720	51.07	4.97	56.04	-54.76	110.8	105	110	Peak
5	5725	57.67	5	62.67	-59.53	122.2	105	110	Peak
6	5740.085	91.9	5.05	96.95	-25.25	122.2	105	110	Peak

Note: The EUT Power by Notebook PC

- "*" means the worst value in this measurement data.
- C.F (Correction Factor) = Antenna Factor (dB)+ Cable Loss (dB) – Preamplifier(dB)
- Measurement (dBUV/m) = Reading(dBUV) + C.F (Correction Factor)

EUT	Wireless module	Test Date	2019/6/4
Factor	BBHA 9120D	Temp. / Humidity	21°C / 57%
Polarity	Horizontal	Site / Engineer	AC1 / Peter
Test Mode	MODE2-CH165	Test Voltage	AC 120V/60Hz

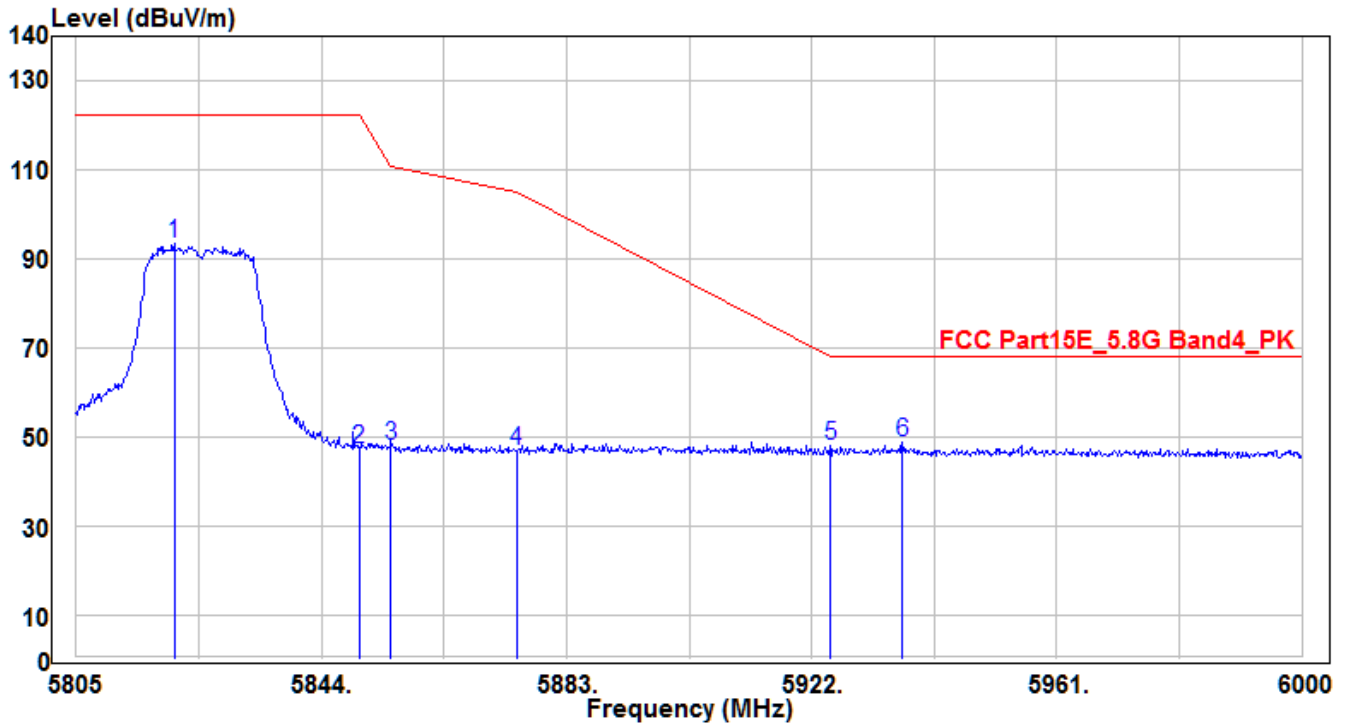

No	Frequency (MHz)	Reading (dBuV)	C.F (dB)	Measurement (dBuV/m)	Margin (dB)	Limit (dBuV)	Height (cm)	Angle (deg)	Remark (QP/PK/AV)
1	5820.6	88.07	5.3	93.37	-28.83	122.2	170	155	Peak
2	5850	42.09	5.4	47.49	-74.71	122.2	170	155	Peak
3	5855	42.67	5.43	48.1	-62.7	110.8	170	155	Peak
4	5875	41.58	5.49	47.07	-58.13	105.2	170	155	Peak
5	5925	42.5	5.65	48.15	-20.05	68.2	170	155	Peak
6	* 5936.43	43.21	5.68	48.89	-19.31	68.2	170	155	Peak

Note: The EUT Power by Notebook PC

1. " * " means the worst value in this measurement data.
2. C.F (Correction Factor) = Antenna Factor (dB)+ Cable Loss (dB) – Preamplifier(dB)
3. Measurement (dBuV/m) = Reading(dBuV) + C.F (Correction Factor)

EUT	Wireless module	Test Date	2019/6/4
Factor	BBHA 9120D	Temp. / Humidity	21°C / 57%
Polarity	Vertical	Site / Engineer	AC1 / Peter
Test Mode	MODE2-CH165	Test Voltage	AC 120V/60Hz

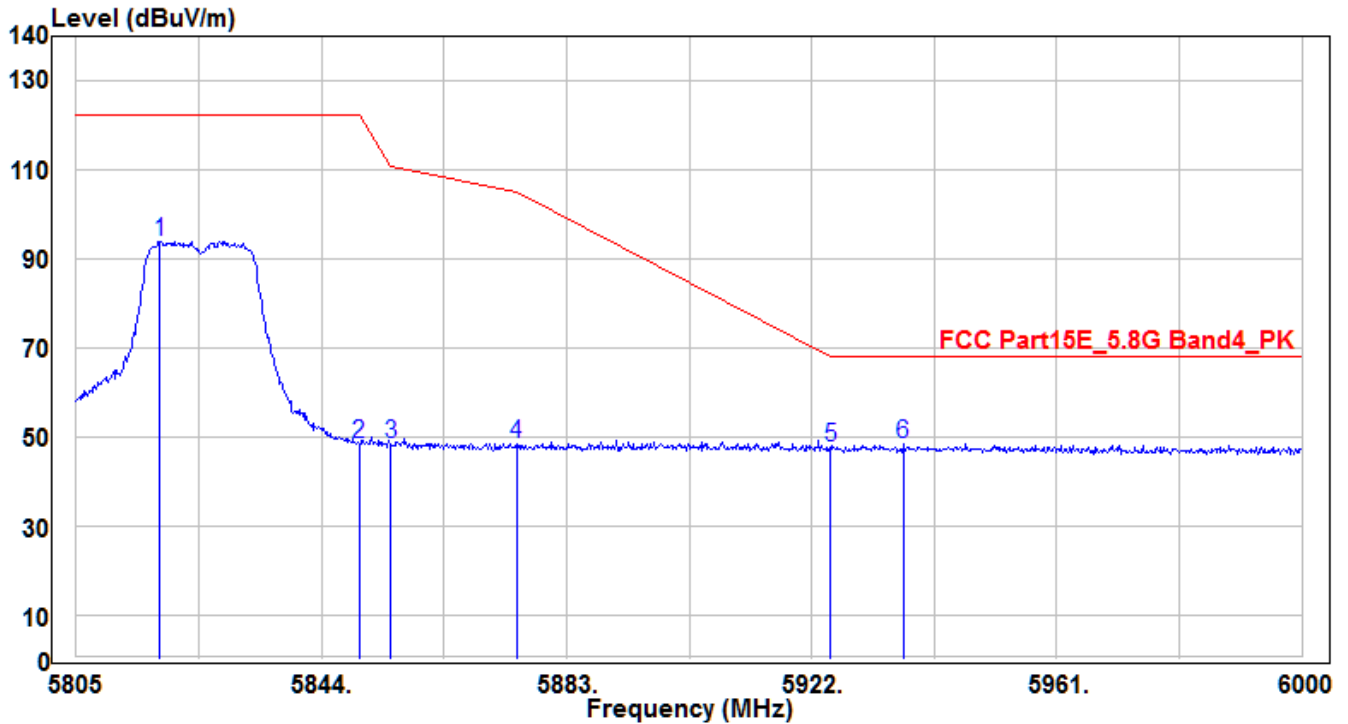

No	Frequency (MHz)	Reading (dBuV)	C.F (dB)	Measurement (dBuV/m)	Margin (dB)	Limit (dBuV)	Height (cm)	Angle (deg)	Remark (QP/PK/AV)
1	5818.26	88.67	5.3	93.97	-28.23	122.2	105	110	Peak
2	5850	42.95	5.4	48.35	-73.85	122.2	105	110	Peak
3	5855	43.09	5.43	48.52	-62.28	110.8	105	110	Peak
4	5875	42.82	5.49	48.31	-56.89	105.2	105	110	Peak
5	5925	42	5.65	47.65	-20.55	68.2	105	110	Peak
6	* 5936.625	42.75	5.68	48.43	-19.77	68.2	105	110	Peak

Note: The EUT Power by Notebook PC

- "*" means the worst value in this measurement data.
- C.F (Correction Factor) = Antenna Factor (dB)+ Cable Loss (dB) – Preamplifier(dB)
- Measurement (dBuV/m) = Reading(dBuV) + C.F (Correction Factor)

EUT	Wireless module	Test Date	2019/6/4
Factor	BBHA 9120D	Temp. / Humidity	21°C / 57%
Polarity	Horizontal	Site / Engineer	AC1 / Peter
Test Mode	MODE3-CH38	Test Voltage	AC 120V/60Hz

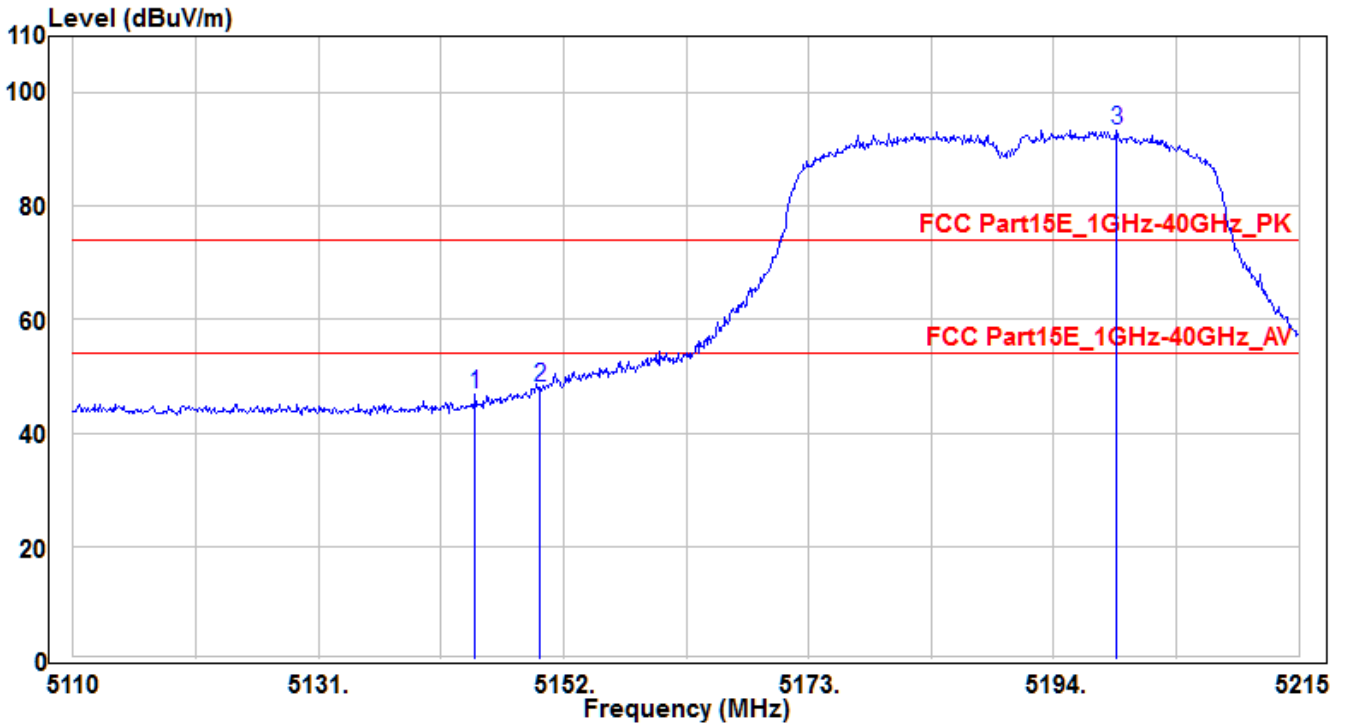

No	Frequency (MHz)	Reading (dBuV)	C.F (dB)	Measurement (dBuV/m)	Margin (dB)	Limit (dBuV)	Height (cm)	Angle (deg)	Remark (QP/PK/AV)
1	5144.44	43.08	3.9	46.98	-27.02	74	150	165	Peak
2	* 5150	44.14	3.91	48.05	-25.95	74	150	165	Peak
3	5199.355	89.57	3.96	93.53	19.53	74	150	165	Peak

Note: The EUT Power by Notebook PC

1. " * " means the worst value in this measurement data.
2. C.F (Correction Factor) = Antenna Factor (dB)+ Cable Loss (dB) – Preamplifier(dB)
3. Measurement (dBuV/m) = Reading(dBuV) + C.F (Correction Factor)

EUT	Wireless module	Test Date	2019/6/4
Factor	BBHA 9120D	Temp. / Humidity	21°C / 57%
Polarity	Vertical	Site / Engineer	AC1 / Peter
Test Mode	MODE3-CH38	Test Voltage	AC 120V/60Hz

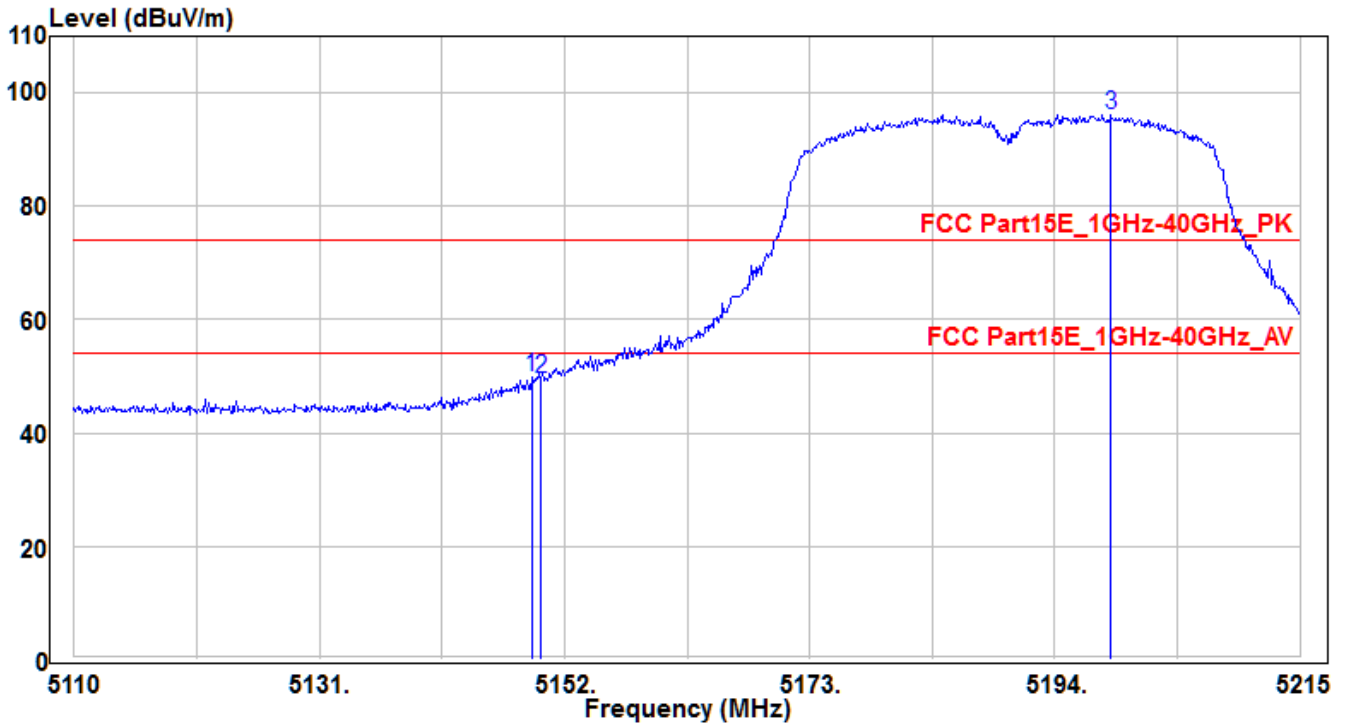

No	Frequency (MHz)	Reading (dBuV)	C.F (dB)	Measurement (dBuV/m)	Margin (dB)	Limit (dBuV)	Height (cm)	Angle (deg)	Remark (QP/PK/AV)
1	* 5149.165	46.09	3.91	50	-24	74	150	180	Peak
2	5150	45.64	3.91	49.55	-24.45	74	150	180	Peak
3	5198.83	92.21	3.96	96.17	22.17	74	150	180	Peak

Note: The EUT Power by Notebook PC

1. " * " means the worst value in this measurement data.
2. C.F (Correction Factor) = Antenna Factor (dB)+ Cable Loss (dB) – Preamplifier(dB)
3. Measurement (dBuV/m) = Reading(dBuV) + C.F (Correction Factor)

EUT	Wireless module	Test Date	2019/6/4
Factor	BBHA 9120D	Temp. / Humidity	21°C / 57%
Polarity	Horizontal	Site / Engineer	AC1 / Peter
Test Mode	MODE3-CH151	Test Voltage	AC 120V/60Hz

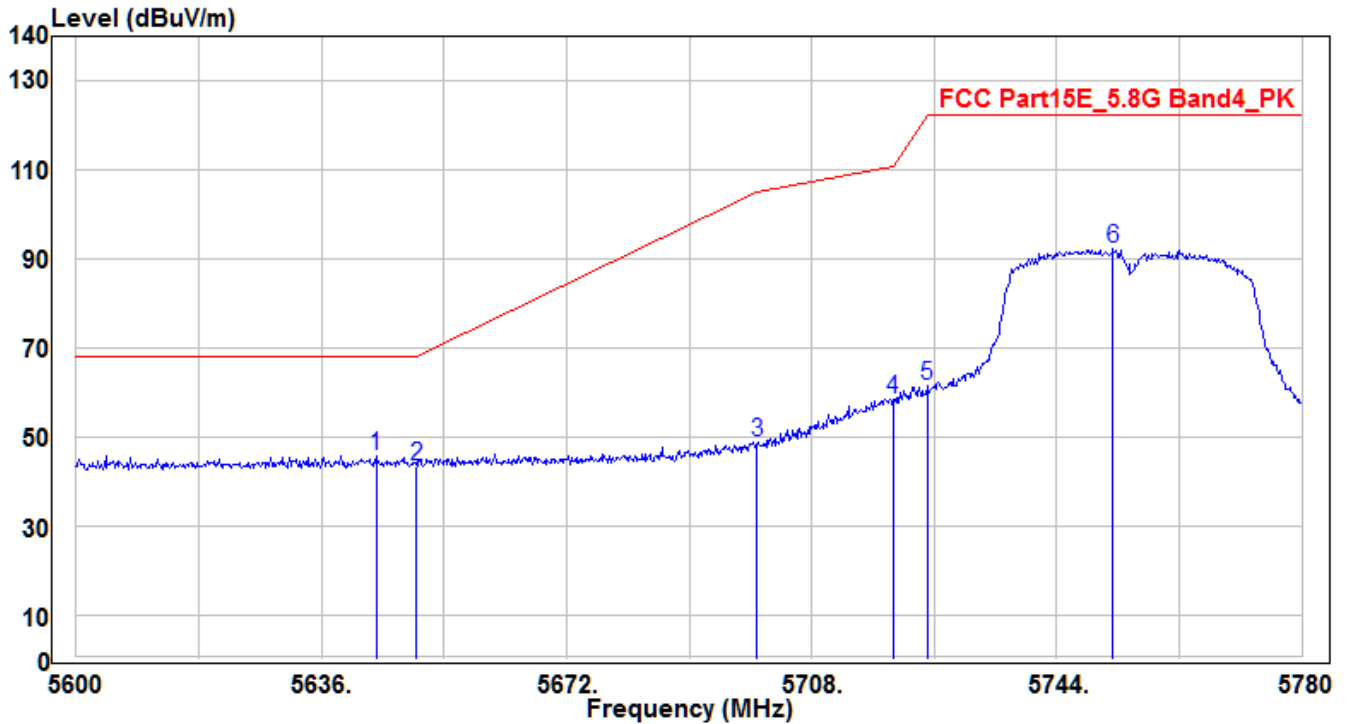

No	Frequency (MHz)	Reading (dBUV)	C.F (dB)	Measurement (dBUV/m)	Margin (dB)	Limit (dBUV)	Height (cm)	Angle (deg)	Remark (QP/PK/AV)
1	* 5644.1	41.21	4.73	45.94	-22.26	68.2	170	155	Peak
2	5650	38.8	4.76	43.56	-24.64	68.2	170	155	Peak
3	5700	43.97	4.92	48.89	-56.31	105.2	170	155	Peak
4	5720	53.32	4.97	58.29	-52.51	110.8	170	155	Peak
5	5725	56.53	5	61.53	-60.67	122.2	170	155	Peak
6	5752.28	87.09	5.08	92.17	-30.03	122.2	170	155	Peak

Note: The EUT Power by Notebook PC

1. " * " means the worst value in this measurement data.
2. C.F (Correction Factor) = Antenna Factor (dB)+ Cable Loss (dB) – Preamplifier(dB)
3. Measurement (dBUV/m) = Reading(dBUV) + C.F (Correction Factor)

EUT	Wireless module	Test Date	2019/6/4
Factor	BBHA 9120D	Temp. / Humidity	21°C / 57%
Polarity	Vertical	Site / Engineer	AC1 / Peter
Test Mode	MODE3-CH151	Test Voltage	AC 120V/60Hz

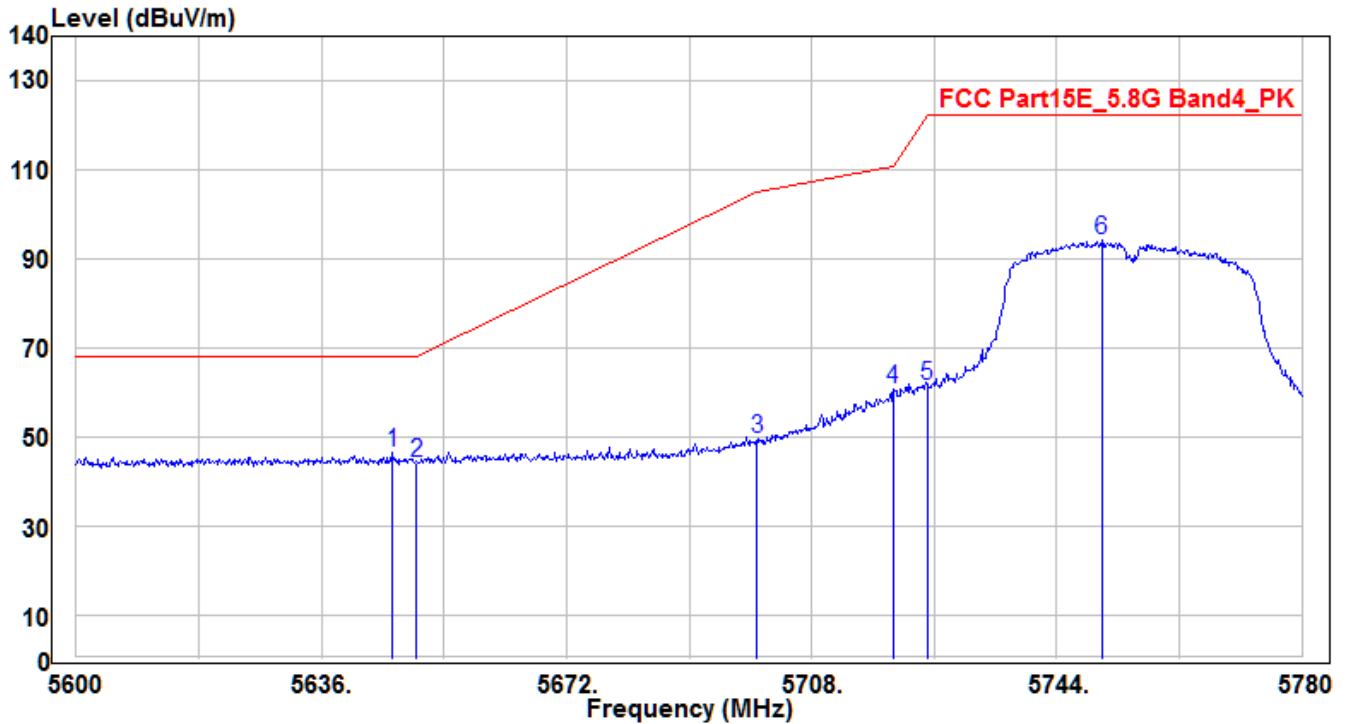

No		Frequency (MHz)	Reading (dBuV)	C.F (dB)	Measurement (dBuV/m)	Margin (dB)	Limit (dBuV)	Height (cm)	Angle (deg)	Remark (QP/PK/AV)
1	*	5646.44	41.74	4.75	46.49	-21.71	68.2	105	165	Peak
2		5650	39.67	4.76	44.43	-23.77	68.2	105	165	Peak
3		5700	44.77	4.92	49.69	-55.51	105.2	105	165	Peak
4		5720	55.65	4.97	60.62	-50.18	110.8	105	165	Peak
5		5725	56.61	5	61.61	-60.59	122.2	105	165	Peak
6		5750.66	88.99	5.08	94.07	-28.13	122.2	105	165	Peak

Note: The EUT Power by Notebook PC

1. " * " means the worst value in this measurement data.
2. C.F (Correction Factor) = Antenna Factor (dB)+ Cable Loss (dB) – Preamplifier(dB)
3. Measurement (dBuV/m) = Reading(dBuV) + C.F (Correction Factor)

EUT	Wireless module	Test Date	2019/6/4
Factor	BBHA 9120D	Temp. / Humidity	21°C / 57%
Polarity	Horizontal	Site / Engineer	AC1 / Peter
Test Mode	MODE3-CH159	Test Voltage	AC 120V/60Hz

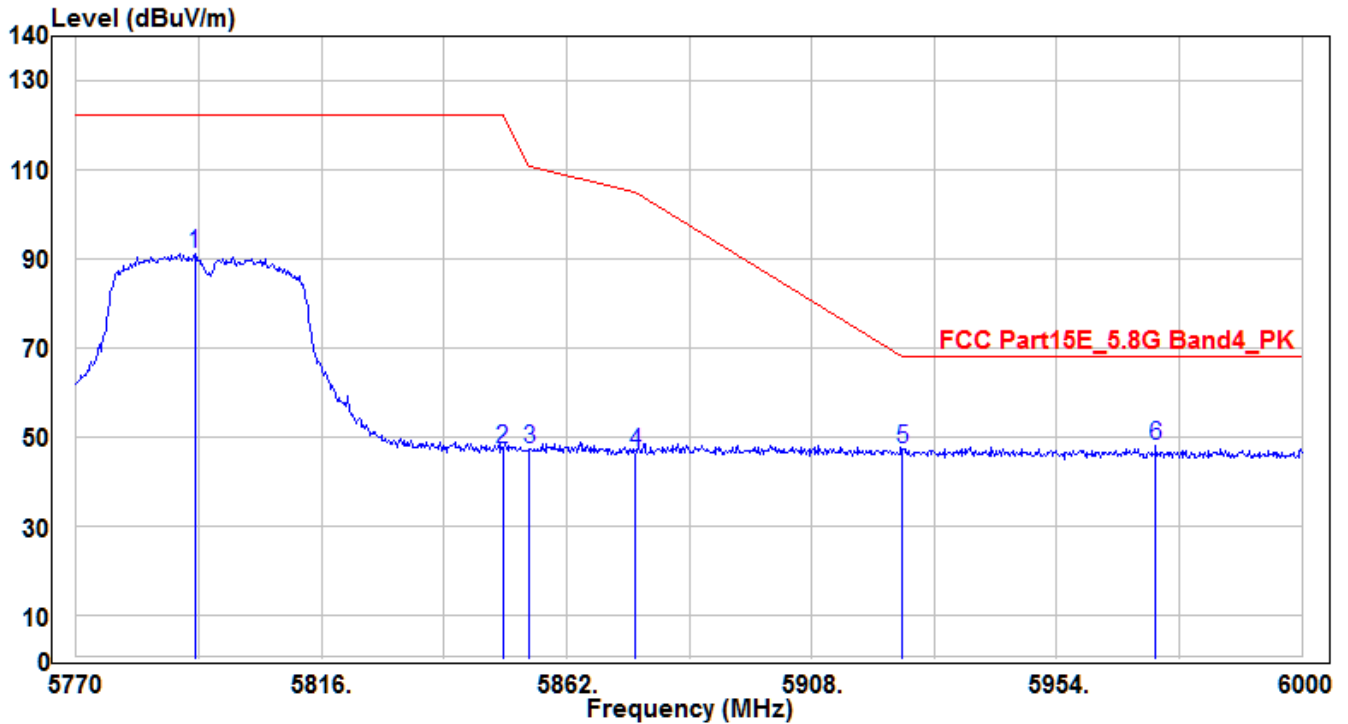

No	Frequency (MHz)	Reading (dBuV)	C.F (dB)	Measurement (dBuV/m)	Margin (dB)	Limit (dBuV)	Height (cm)	Angle (deg)	Remark (QP/PK/AV)
1	5792.31	85.89	5.22	91.11	-31.09	122.2	170	155	Peak
2	5850	41.97	5.4	47.37	-74.83	122.2	170	155	Peak
3	5855	42.05	5.43	47.48	-63.32	110.8	170	155	Peak
4	5875	40.94	5.49	46.43	-58.77	105.2	170	155	Peak
5	5925	41.64	5.65	47.29	-20.91	68.2	170	155	Peak
6	* 5972.63	42.31	5.81	48.12	-20.08	68.2	170	155	Peak

Note: The EUT Power by Notebook PC

1. " * " means the worst value in this measurement data.
2. C.F (Correction Factor) = Antenna Factor (dB)+ Cable Loss (dB) – Preamplifier(dB)
3. Measurement (dBuV/m) = Reading(dBuV) + C.F (Correction Factor)

EUT	Wireless module	Test Date	2019/6/4
Factor	BBHA 9120D	Temp. / Humidity	21°C / 57%
Polarity	Vertical	Site / Engineer	AC1 / Peter
Test Mode	MODE3-CH159	Test Voltage	AC 120V/60Hz

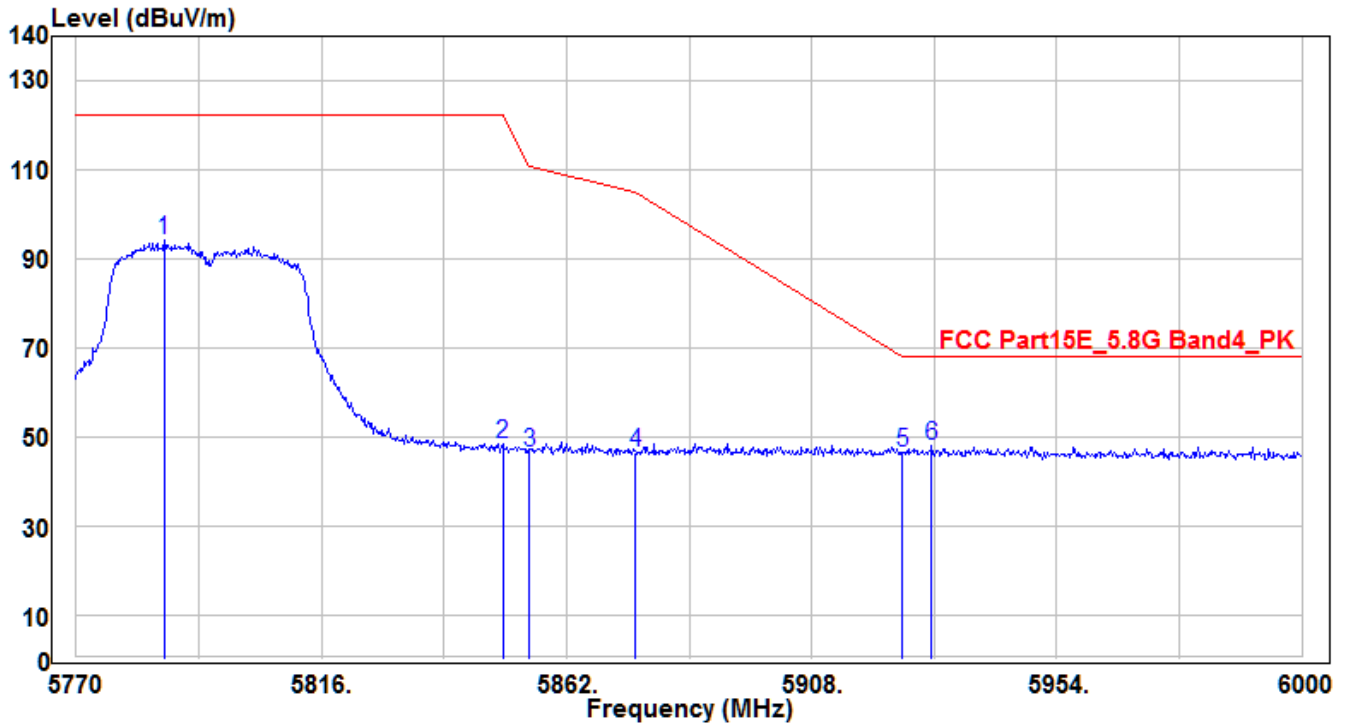

No	Frequency (MHz)	Reading (dBuV)	C.F (dB)	Measurement (dBuV/m)	Margin (dB)	Limit (dBuV)	Height (cm)	Angle (deg)	Remark (QP/PK/AV)
1	5786.56	89.24	5.19	94.43	-27.77	122.2	105	110	Peak
2	5850	42.96	5.4	48.36	-73.84	122.2	105	110	Peak
3	5855	41.02	5.43	46.45	-64.35	110.8	105	110	Peak
4	5875	41.08	5.49	46.57	-58.63	105.2	105	110	Peak
5	5925	40.76	5.65	46.41	-21.79	68.2	105	110	Peak
6	*s 5930.54	42.43	5.67	48.1	-20.1	68.2	105	110	Peak

Note: The EUT Power by Notebook PC

1. " * " means the worst value in this measurement data.
2. C.F (Correction Factor) = Antenna Factor (dB)+ Cable Loss (dB) – Preamplifier(dB)
3. Measurement (dBuV/m) = Reading(dBuV) + C.F (Correction Factor)

7.9. AC Conducted Emissions Measurement

7.9.1. Test Limit

FCC Part 15.207 Limits / IC RSS-Gen Table 3 Limits		
Frequency (MHz)	QP (dB μ V)	AV (dB μ V)
0.15 ~ 0.50	66 ~ 56	56 ~ 46
0.50 ~ 5.0	56	46
5.0 ~ 30	60	50

Note 1: The lower limit shall apply at the transition frequencies.

Note 2: The limit decreases linearly with the logarithm of the frequency in the range 0.15MHz to 0.5MHz.

7.9.2. Test Procedure

The EUT was setup according to ANSI C63.4, 2009 and tested according to KDB 789033 for compliance to FCC 47CFR 15.247 requirements. The EUT was placed on a platform of nominal size, 1 m by 1.5 m, raised 80 cm above the conducting ground plane. The vertical conducting plane was located 40 cm to the rear of the EUT. All other surfaces of EUT were at least 80 cm from any other grounded conducting surface. The EUT and simulators are connected to the main power through a line impedance stabilization network (LISN). The LISN provides a 50 ohm /50uH coupling impedance for the measuring equipment. The peripheral devices are also connected to the main power through a LISN. (Please refer to the block diagram of the test setup and photographs) Each current-carrying conductor of the EUT power cord, except the ground (safety) conductor, was individually connected through a LISN to the input power source.

The excess length of the power cord between the EUT and the LISN receptacle were folded back and forth at the center of the lead to form a bundle not exceeding 40 cm in length.

Conducted emissions were investigated over the frequency range from 0.15MHz to 30MHz using a receiver bandwidth of 9 kHz.

7.9.3. Test Setup

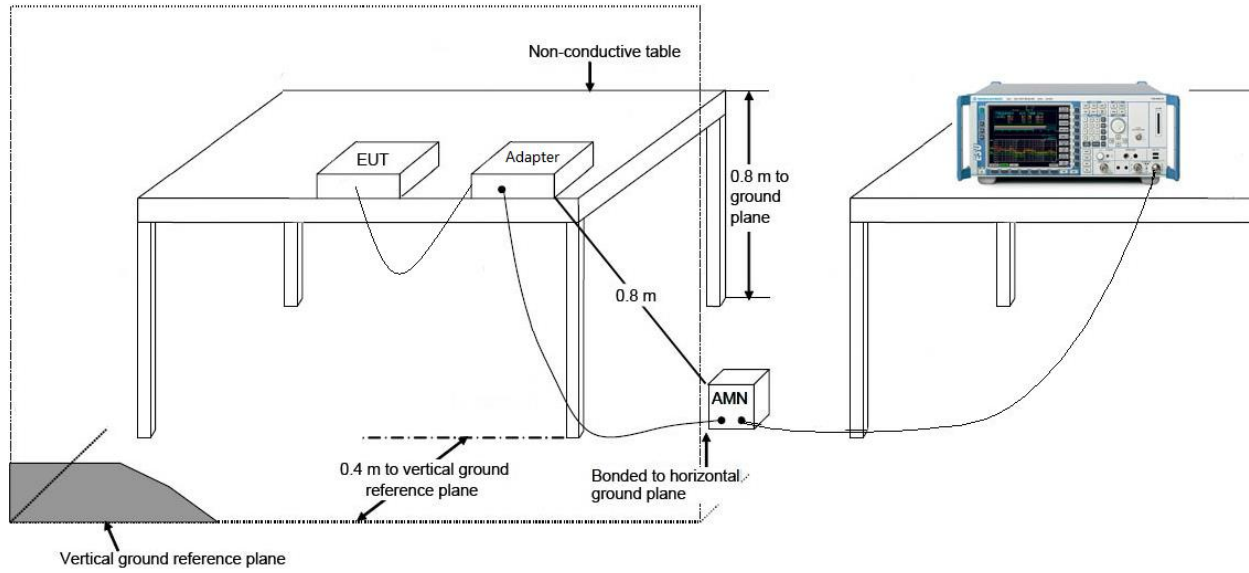

7.9.4. Test Result

EUT	Wireless module	Test Date	2019/5/7
Factor	CE_ENV216-L1 (Filter ON)	Temp. / Humidity	24°C / 55%
Polarity	Line1	Site / Engineer	SR2 / Peter
Test Mode	MODE2	Test Voltage	AC120V/60Hz

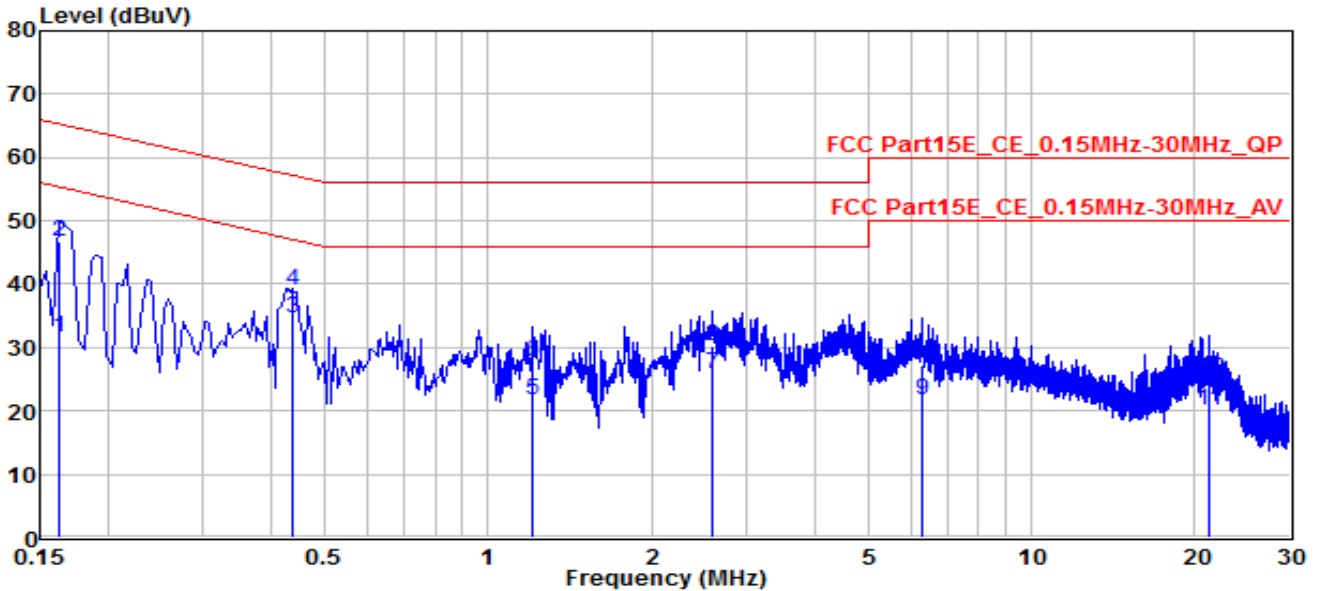

No	Frequency (MHz)	Reading (dBuV)	C.F (dB)	Measurement (dBuV)	Margin (dB)	Limit (dBuV)	Remark (QP/PK/AV)
1	0.1635	21.57	10.12	31.69	-23.59	55.28	Average
2	0.1635	36.74	10.12	46.86	-18.42	65.28	QP
3	* 0.43797	24.56	10.07	34.63	-12.47	47.1	Average
4	* 0.43797	28.88	10.07	38.95	-18.15	57.1	QP
5	1.212	11.92	9.88	21.8	-24.2	46	Average
6	1.212	17.99	9.88	27.87	-28.13	56	QP
7	2.584	16.03	9.85	25.88	-20.12	46	Average
8	2.584	20.29	9.85	30.14	-25.86	56	QP
9	6.323	11.97	9.78	21.75	-28.25	50	Average
10	6.323	17.4	9.78	27.18	-32.82	60	QP
11	21.235	10.06	10.01	20.07	-29.93	50	Average
12	21.235	15	10.01	25.01	-34.99	60	QP

Note: The EUT Power by Notebook PC

- "*" means the worst value in this measurement data.
- C.F (Correction Factor) = Factor (dB)+ Cable Loss (dB)
- Measurement (dBuV) = Reading(dBuV)+ C.F (Correction Factor)
- Other mode was also verified. The test results shown represent the worst case emissions.

EUT	Wireless module	Test Date	2019/5/7
Factor	CE_ENV216-N (Filter ON)	Temp. / Humidity	24°C / 55%
Polarity	Neutral	Site / Engineer	SR2 / Peter
Test Mode	MODE2	Test Voltage	AC120V/60Hz

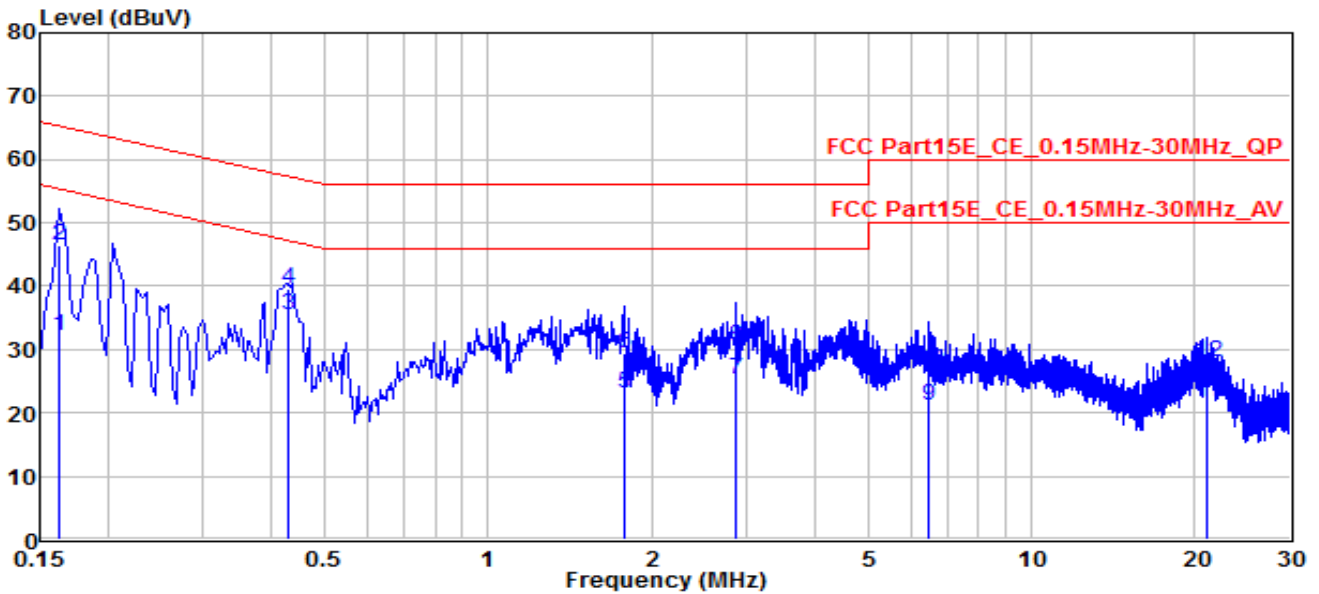

No	Frequency (MHz)	Reading (dBuV)	C.F (dB)	Measurement (dBuV)	Margin (dB)	Limit (dBuV)	Remark (QP/PK/AV)
1	0.1635	22.09	10.1	32.19	-23.09	55.28	Average
2	0.1635	36.39	10.1	46.49	-18.79	65.28	QP
3	* 0.42897	25.31	10.08	35.39	-11.88	47.27	Average
4	* 0.42897	29.45	10.08	39.53	-17.74	57.27	QP
5	1.779	13.2	9.87	23.07	-22.93	46	Average
6	1.779	19.6	9.87	29.47	-26.53	56	QP
7	2.872	15.34	9.82	25.16	-20.84	46	Average
8	2.872	20.82	9.82	30.64	-25.36	56	QP
9	6.463	11.43	9.77	21.2	-28.8	50	Average
10	6.463	16.88	9.77	26.65	-33.35	60	QP
11	21.055	11.55	10.07	21.62	-28.38	50	Average
12	21.055	17.93	10.07	28	-32	60	QP

Note: The EUT Power by Notebook PC

- " * " means the worst value in this measurement data.
- C.F (Correction Factor) = Factor (dB)+ Cable Loss (dB)
- Measurement (dBuV) = Reading(dBuV)+ C.F (Correction Factor)
- Other channel was also verified. The test results shown represent the worst case emissions.

8. CONCLUSION

The data collected relate only the item(s) tested and show that the **Wireless module ,Model Number: BTA-QA4020-1** is in compliance with Part 15E & IC RSS-247 of the FCC Rules & IC Rules.

————— The End —————