

2.7.4 Test Result

1 Mbps-DH5

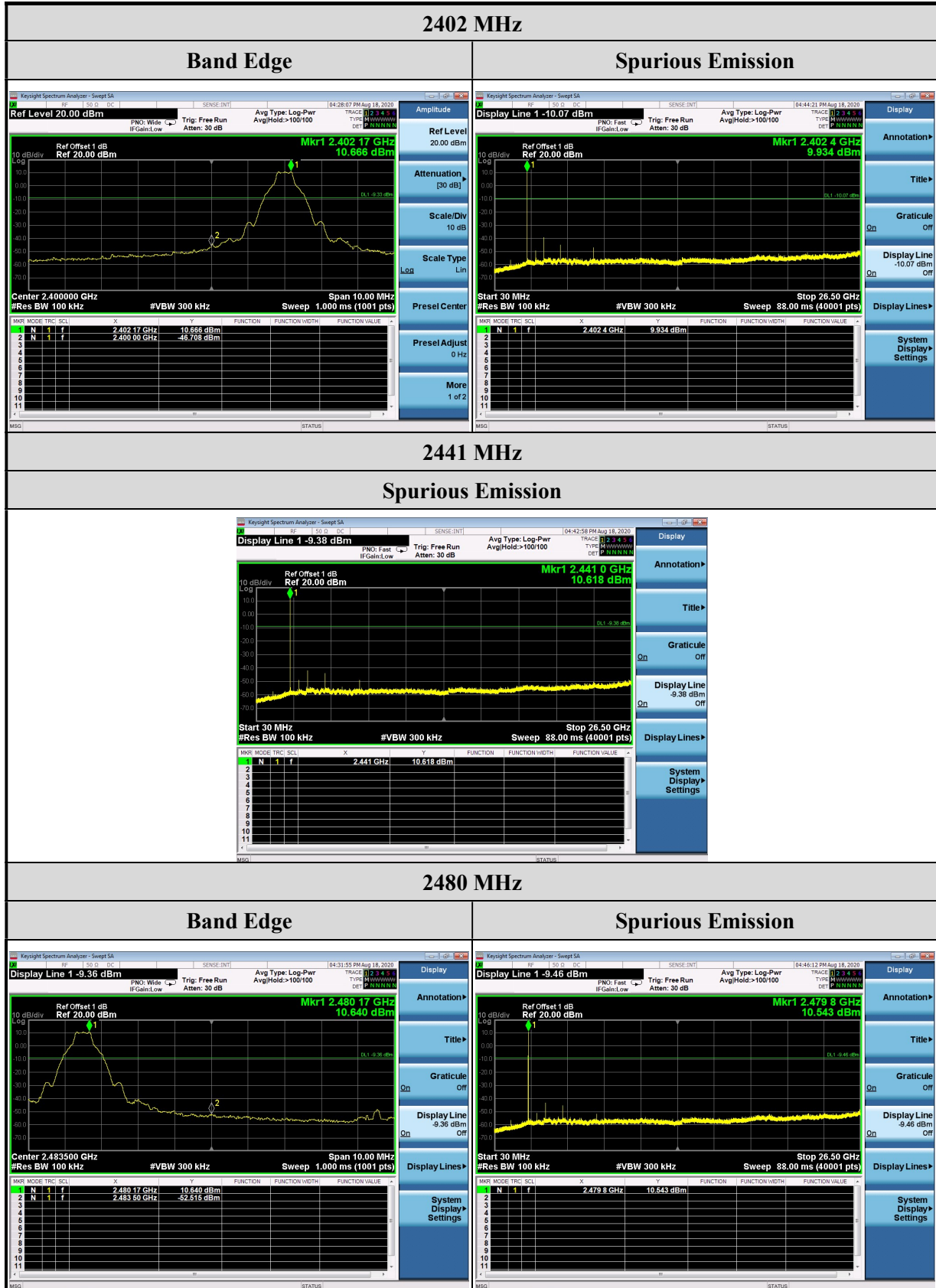

3 Mbps-DH5

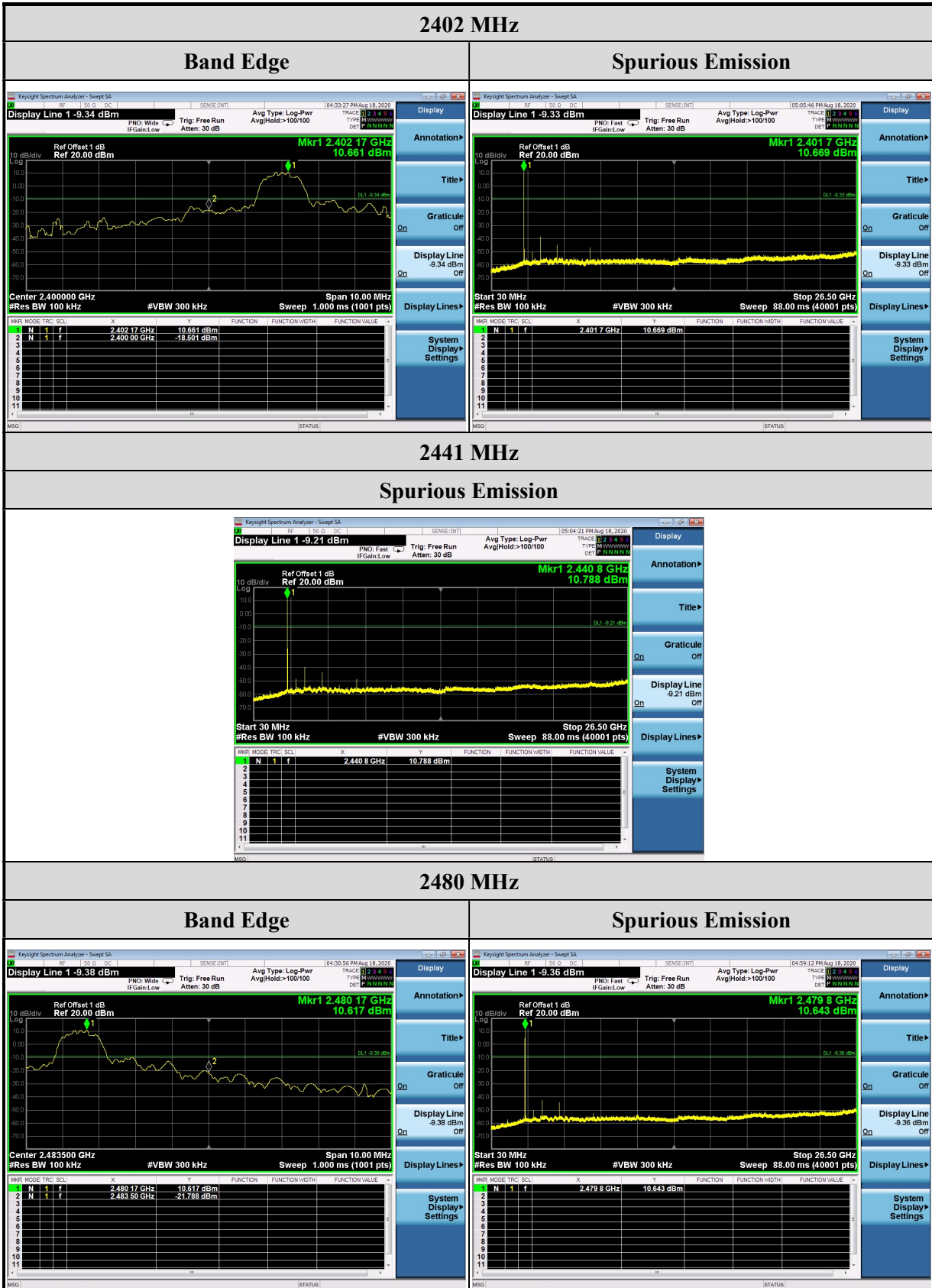

1 Mbps-DH5 Hopping Band Edge

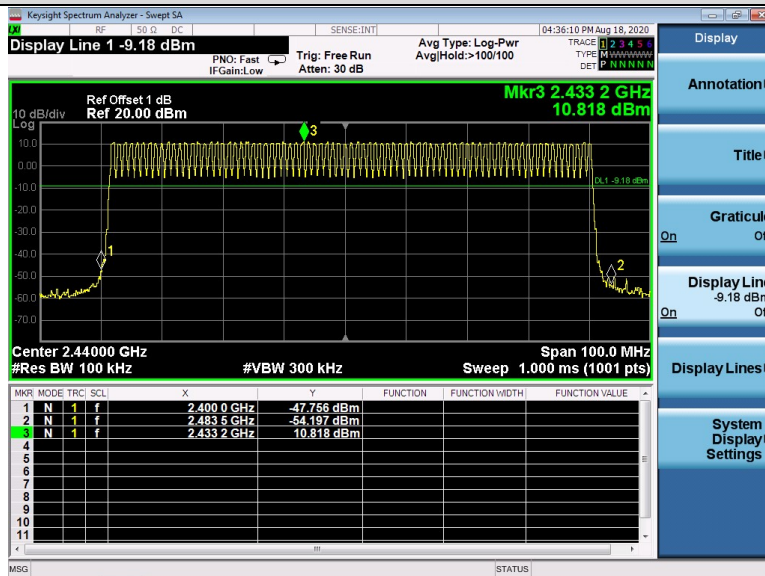

3 Mbps-DH5 Hopping Band Edge

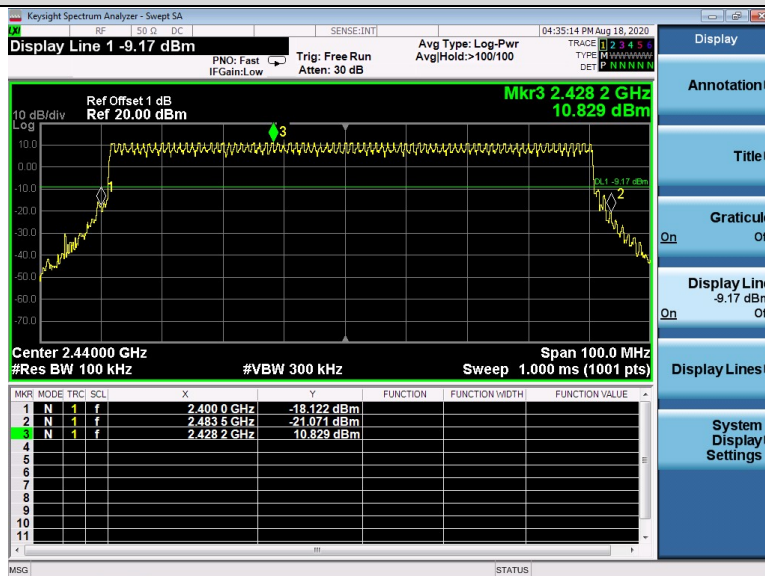

2.8 Radiated Band Edges and Spurious Emission Measurement

2.8.1 Limit

Frequency (MHz)	Field Strength ($\mu\text{V/m}$)	Measurement Distance (m)
0.009 – 0.490	2400/F(kHz)	300
0.490 – 1.705	24000/F(kHz)	30
1.705 – 30.0	30	30
30 – 88	100	3
88 – 216	150	3
216 - 960	200	3
Above 960	500	3

Remarks:

1. RF Voltage (dBuV) = $20 \log \text{RF Voltage}(\mu\text{V})$
2. In the Above Table, the tighter limit applies at the band edges.
3. Distance refers to the distance in meters between the measuring instrument antenna and the closed point of any part of the device or system

2.8.2 Test Setup

Below 30MHz

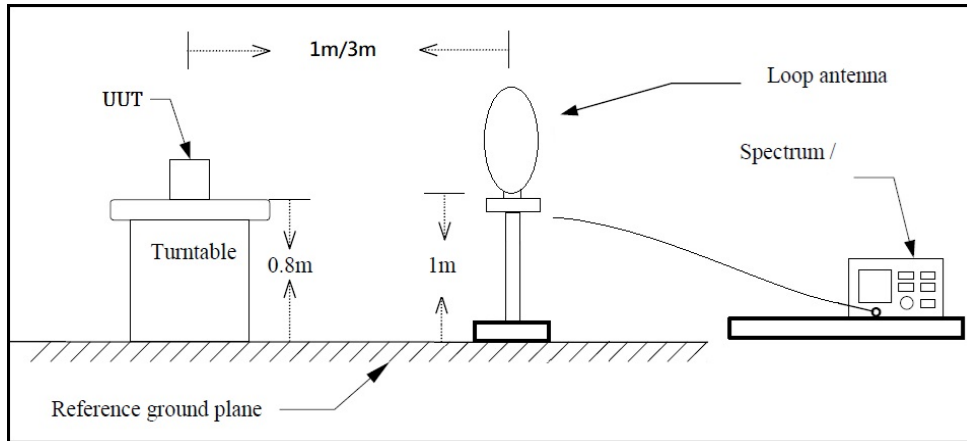

30MHz~1GHz

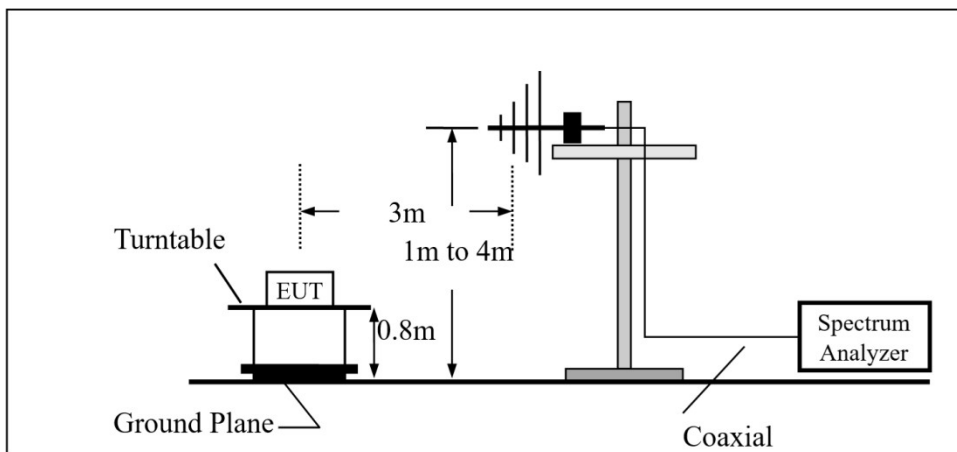

Above 1GHz

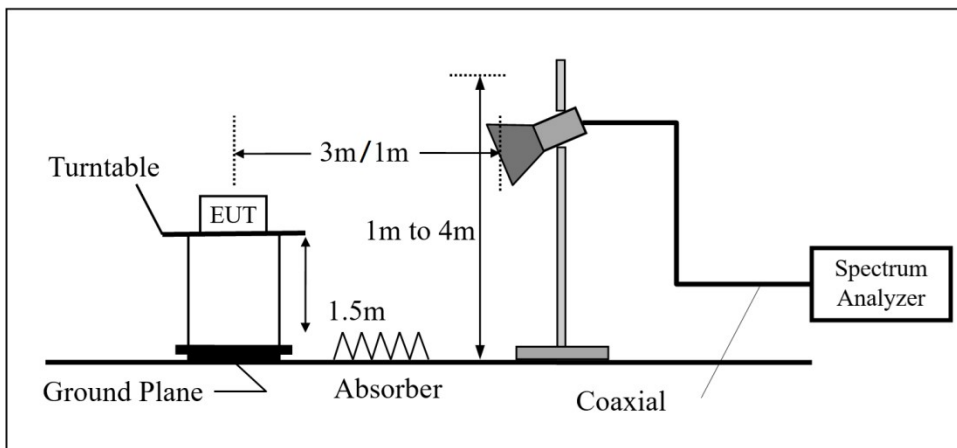

2.8.3 Test Procedure

The EUT was setup according to ANSI C63.10, 2013 and tested according test procedure of KDB 558074 for compliance to FCC 47CFR 15.247 requirements.

For Radiated emission below 30MHz

- (1) The EUT was placed on the top of a rotating table 0.8 meters above the ground in a 3 meter chamber room. The table was rotated 360 degrees to determine the position of the highest radiation.
- (2) The EUT was set 3 meters away from the interference-receiving antenna, which was mounted on the top of a variable-height antenna tower.
- (3) Parallel, perpendicular, and ground-parallel orientations of the antenna are set to make the measurement.
- (4) For each suspected emission, the EUT was arranged to its worst case and the rotatable table was turned from 0 degrees to 360 degrees to find the maximum reading.
- (5) The test-receiver system was set to Quasi-Peak Detect Function and Specified Bandwidth with Maximum Hold Mode.

For Radiated emission Above 30MHz

- (1) The EUT was placed on the top of a rotating table 0.8 meters (for below 1GHz) / 1.5 meters (for above 1GHz) above the ground at 3 meter chamber room for the test. The table was rotated 360 degrees to determine the position of the highest radiation.
- (2) The EUT was set 3 meters away from the interference-receiving antenna, the height of the antenna is varied from 1 meter to 4 meters above the ground to determine the maximum value of the field strength.
- (3) Parallel, perpendicular, and ground-parallel orientations of the antenna are set to make the measurement.
- (4) For each suspected emission, the EUT was arranged to its worst case and the rotatable table was turned from 0 degrees to 360 degrees to find the maximum reading.
- (5) The test-receiver system was set to quasi-peak detect function and specified bandwidth with maximum hold mode when the test frequency is below 1 GHz.
- (6) The test-receiver system was set to peak and average detect function and specified bandwidth with maximum hold mode when the test frequency is above 1 GHz. If the peak reading value also meets the average limit, measurement with the average detector is unnecessary.

2.8.4 Duty Cycle

Mode	Data Rate (Mbps)	on time (ms)	on+off time (ms)	Duty cycle	Duty Factor (dB)	1/T Minimum VBW (kHz)
BT	1	2.908	3.750	0.775	1.104	0.344
	3	2.918	3.750	0.778	1.089	0.343

2.8.5 Test Result of Radiated Band Edge Measurement

The following tables for radiated measurement, pre-scanned in three orthogonal panels, X, Y, Z. The worst cases (X axis) were recorded in this report.

Test Frequency	
RF	BT 1 Mbps / 3 Mbps
Tx	CH00 (2402 MHz)
	CH78 (2480 MHz)

Test Mode :	Transmit BT-BR(1Mbps)	Test Date :	2020/08/17
Test Channel	CH00 (2402 MHz)	Temperature :	25 °C
Polarization :	Horizontal	Relative Humidity :	65 %

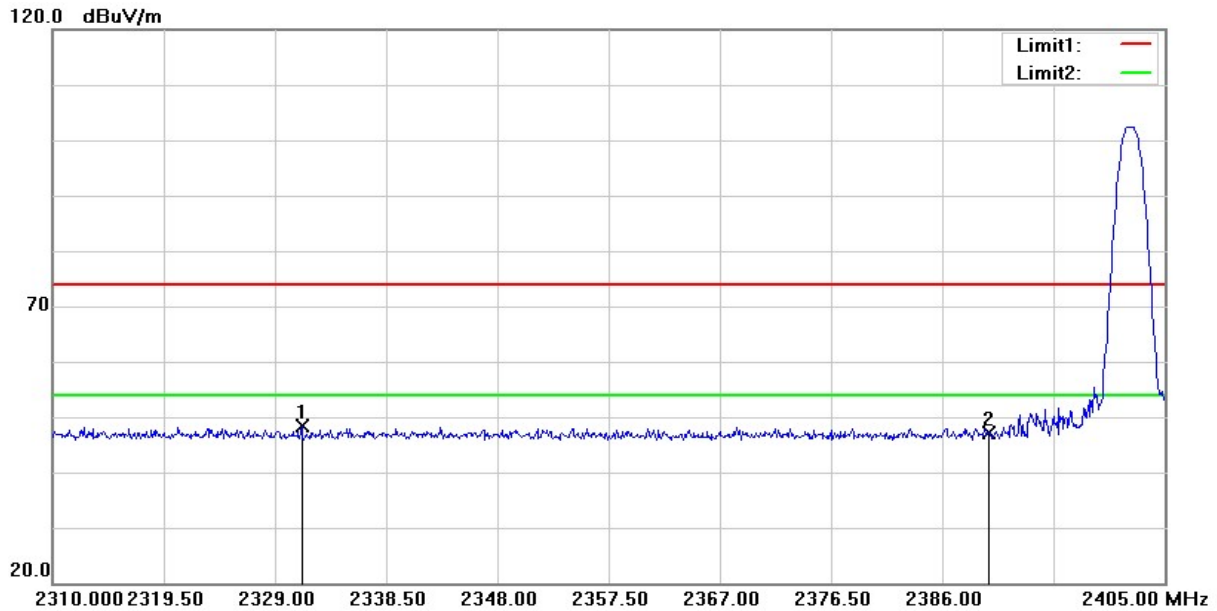

No.	Frequency (MHz)	Reading (dBuV/m)	Correct Factor (dB/m)	Result (dBuV/m)	Limit (dBuV/m)	Margin (dB)	Remark
1	2331.280	54.56	-6.17	48.39	74.00	-25.61	peak
2	2390.000	53.36	-6.28	47.08	74.00	-26.92	peak

Remark :

1. Correction Factor = Antenna factor + Cable loss – Amplifier gain
2. Result Value = Reading Level + Correct Factor
3. Margin Level = Result Value – Limit Value
4. The other emission levels were very low against the limit

Test Mode :	Transmit BT-BR(1Mbps)	Test Date :	2020/08/17
Test Channel	CH00 (2402 MHz)	Temperature :	25 °C
Polarization :	Vertical	Relative Humidity :	65 %

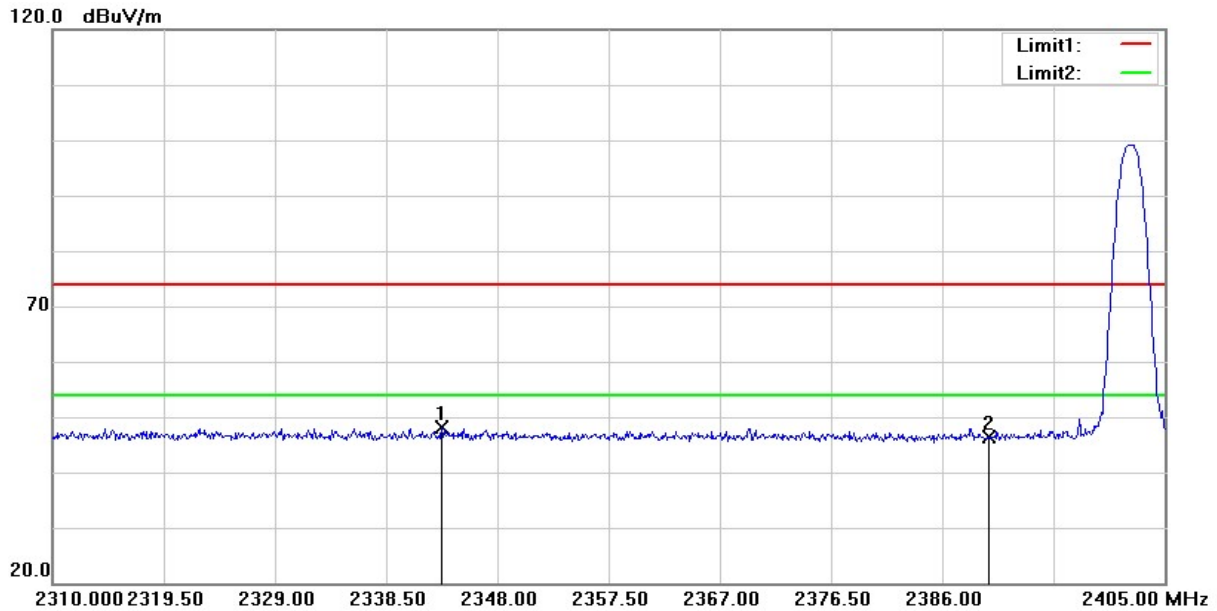

No.	Frequency (MHz)	Reading (dBuV/m)	Correct Factor (dB/m)	Result (dBuV/m)	Limit (dBuV/m)	Margin (dB)	Remark
1	2343.250	54.42	-6.18	48.24	74.00	-25.76	peak
2	2390.000	52.73	-6.28	46.45	74.00	-27.55	peak

Remark :

1. Correction Factor = Antenna factor + Cable loss – Amplifier gain
2. Result Value = Reading Level + Correct Factor
3. Margin Level = Result Value – Limit Value
4. The other emission levels were very low against the limit

Test Mode :	Transmit BT-BR(1Mbps)	Test Date :	2020/08/17
Test Channel	CH78 (2480 MHz)	Temperature :	25 °C
Polarization :	Horizontal	Relative Humidity :	65 %

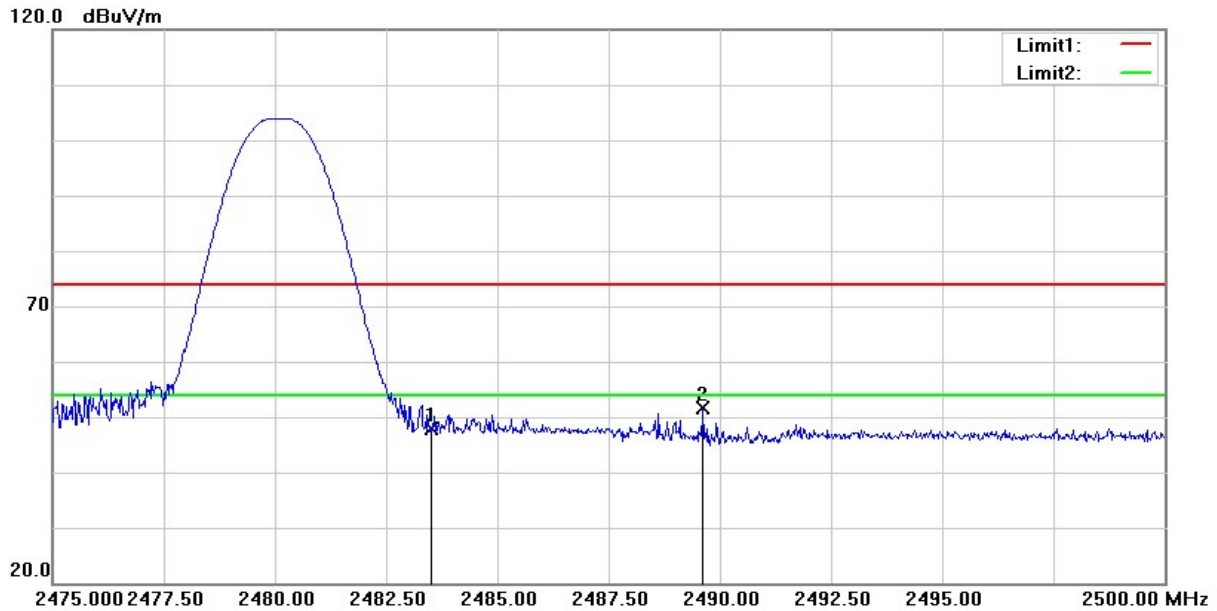

No.	Frequency (MHz)	Reading (dBuV/m)	Correct Factor (dB/m)	Result (dBuV/m)	Limit (dBuV/m)	Margin (dB)	Remark
1	2483.500	54.30	-6.34	47.96	74.00	-26.04	peak
2	2489.625	58.02	-6.36	51.66	74.00	-22.34	peak

Remark :

1. Correction Factor = Antenna factor + Cable loss – Amplifier gain
2. Result Value = Reading Level + Correct Factor
3. Margin Level = Result Value – Limit Value
4. The other emission levels were very low against the limit

Test Mode :	Transmit BT-BR(1Mbps)	Test Date :	2020/08/17
Test Channel	CH78 (2480 MHz)	Temperature :	25 °C
Polarization :	Vertical	Relative Humidity :	65 %

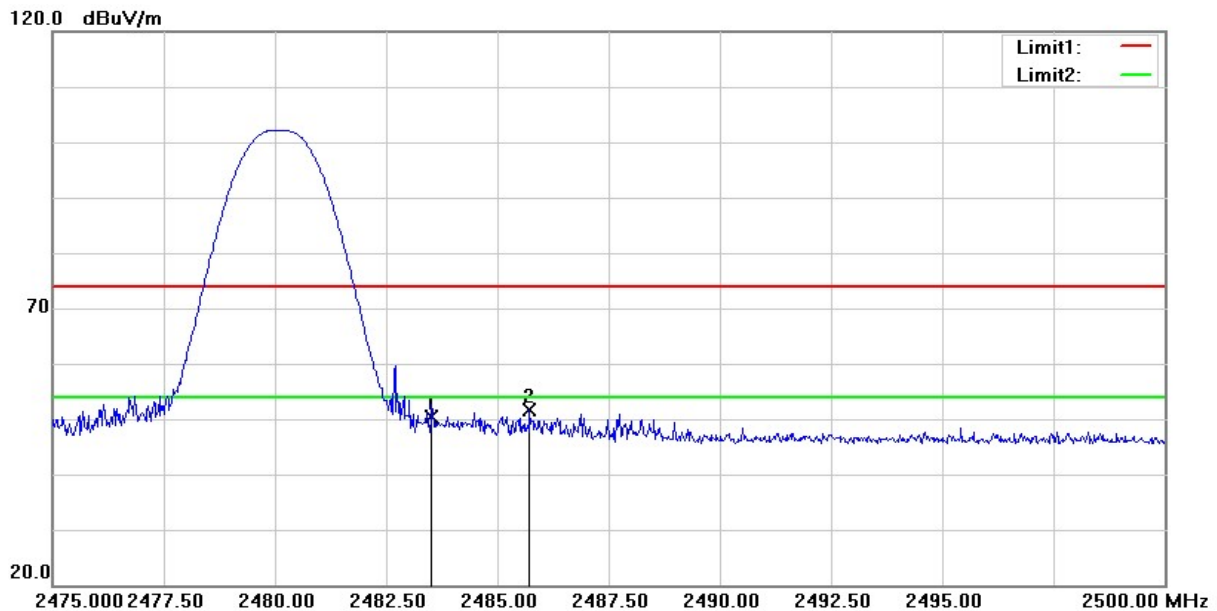

No.	Frequency (MHz)	Reading (dBuV/m)	Correct Factor (dB/m)	Result (dBuV/m)	Limit (dBuV/m)	Margin (dB)	Remark
1	2483.500	56.65	-6.34	50.31	74.00	-23.69	peak
2	2485.725	57.94	-6.35	51.59	74.00	-22.41	peak

Remark :

1. Correction Factor = Antenna factor + Cable loss – Amplifier gain
2. Result Value = Reading Level + Correct Factor
3. Margin Level = Result Value – Limit Value
4. The other emission levels were very low against the limit

Test Mode :	Transmit BT-EDR(3Mbps)	Test Date :	2020/08/17
Test Channel	CH00 (2402 MHz)	Temperature :	25 °C
Polarization :	Horizontal	Relative Humidity :	65 %

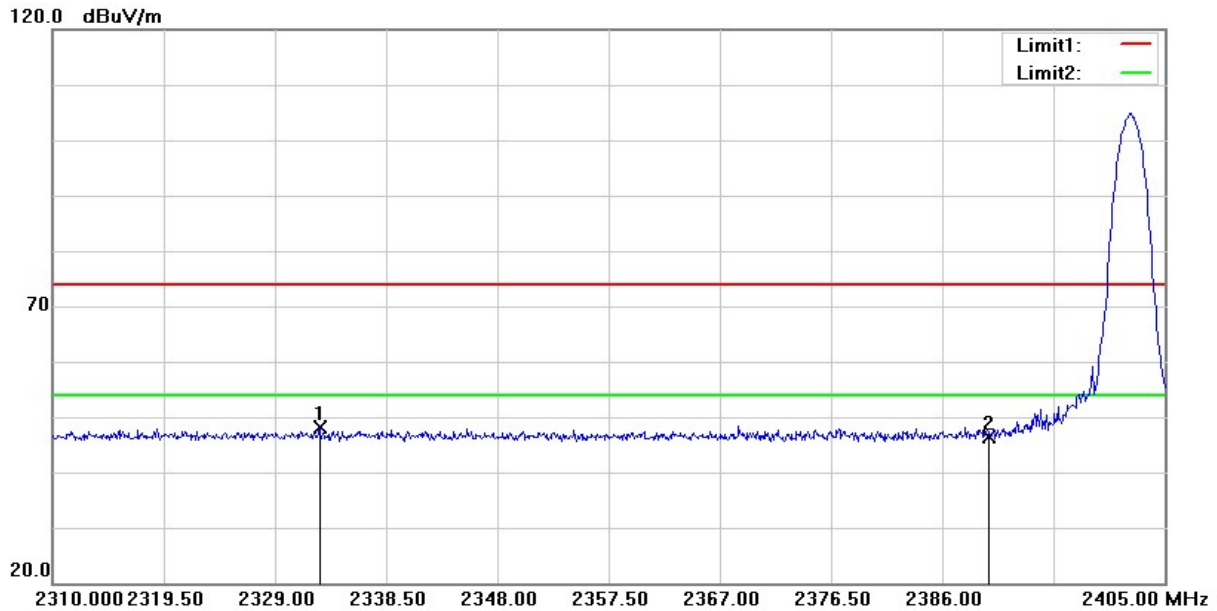

No.	Frequency (MHz)	Reading (dBuV/m)	Correct Factor (dB/m)	Result (dBuV/m)	Limit (dBuV/m)	Margin (dB)	Remark
1	2332.800	54.20	-6.17	48.03	74.00	-25.97	peak
2	2390.000	52.56	-6.28	46.28	74.00	-27.72	peak

Remark :

1. Correction Factor = Antenna factor + Cable loss – Amplifier gain
2. Result Value = Reading Level + Correct Factor
3. Margin Level = Result Value – Limit Value
4. The other emission levels were very low against the limit

Test Mode :	Transmit BT-EDR(3Mbps)	Test Date :	2020/08/17
Test Channel	CH00 (2402 MHz)	Temperature :	25 °C
Polarization :	Vertical	Relative Humidity :	65 %

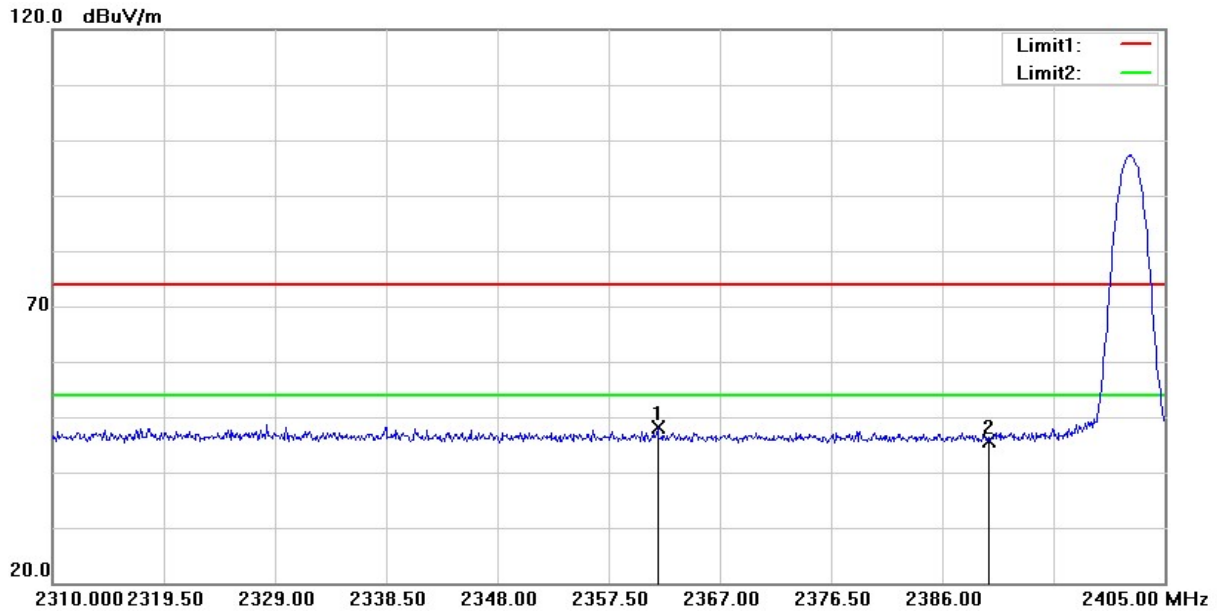

No.	Frequency (MHz)	Reading (dBuV/m)	Correct Factor (dB/m)	Result (dBuV/m)	Limit (dBuV/m)	Margin (dB)	Remark
1	2361.680	54.37	-6.22	48.15	74.00	-25.85	peak
2	2390.000	51.81	-6.28	45.53	74.00	-28.47	peak

Remark :

1. Correction Factor = Antenna factor + Cable loss – Amplifier gain
2. Result Value = Reading Level + Correct Factor
3. Margin Level = Result Value – Limit Value
4. The other emission levels were very low against the limit

Test Mode :	Transmit BT-EDR(3Mbps)	Test Date :	2020/08/17
Test Channel	CH78 (2480 MHz)	Temperature :	25 °C
Polarization :	Horizontal	Relative Humidity :	65 %

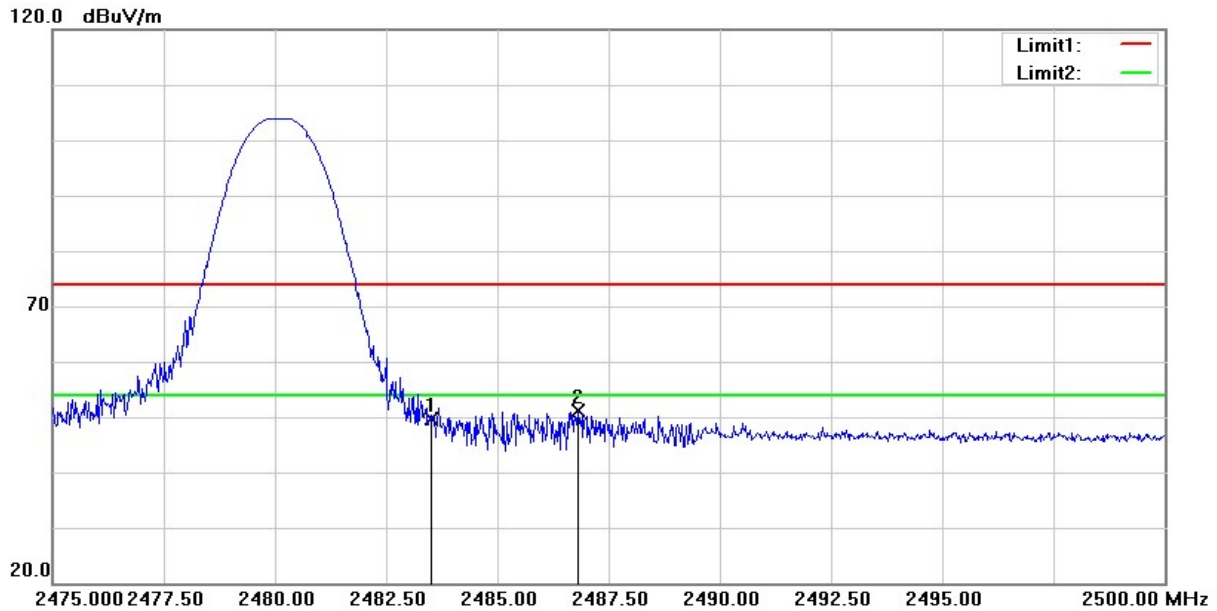

No.	Frequency (MHz)	Reading (dBuV/m)	Correct Factor (dB/m)	Result (dBuV/m)	Limit (dBuV/m)	Margin (dB)	Remark
1	2483.500	55.92	-6.34	49.58	74.00	-24.42	peak
2	2486.800	57.55	-6.36	51.19	74.00	-22.81	peak

Remark :

1. Correction Factor = Antenna factor + Cable loss – Amplifier gain
2. Result Value = Reading Level + Correct Factor
3. Margin Level = Result Value – Limit Value
4. The other emission levels were very low against the limit

Test Mode :	Transmit BT-EDR(3Mbps)	Test Date :	2020/08/17
Test Channel	CH78 (2480 MHz)	Temperature :	25 °C
Polarization :	Vertical	Relative Humidity :	65 %

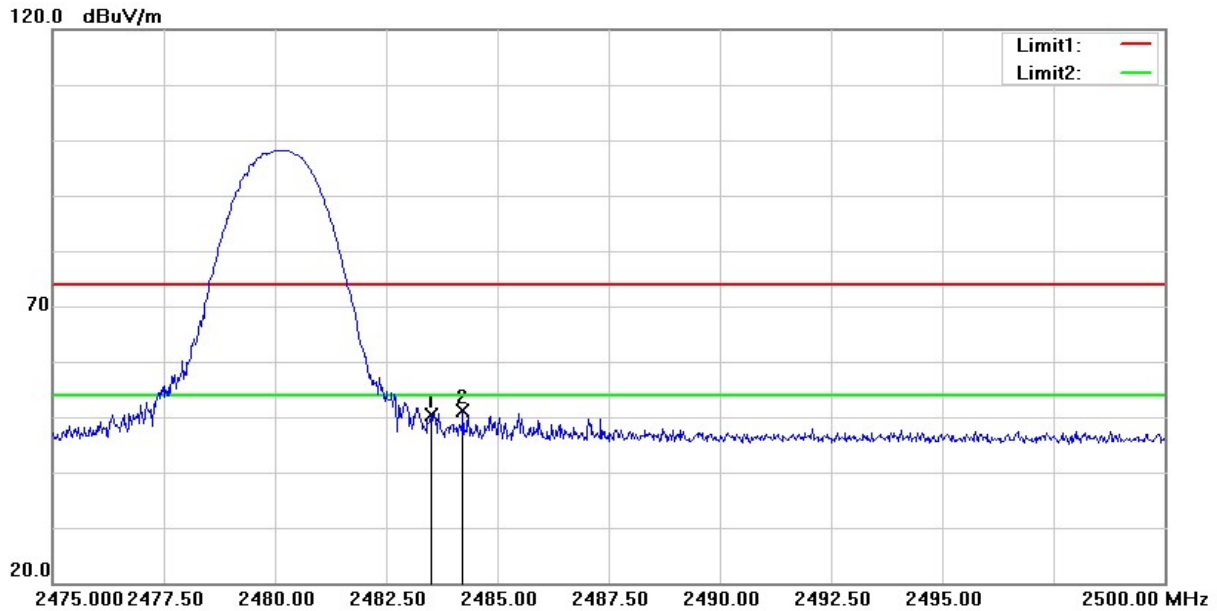

No.	Frequency (MHz)	Reading (dBuV/m)	Correct Factor (dB/m)	Result (dBuV/m)	Limit (dBuV/m)	Margin (dB)	Remark
1	2483.500	56.64	-6.34	50.30	74.00	-23.70	peak
2	2484.225	57.51	-6.35	51.16	74.00	-22.84	peak

Remark :

1. Correction Factor = Antenna factor + Cable loss – Amplifier gain
2. Result Value = Reading Level + Correct Factor
3. Margin Level = Result Value – Limit Value
4. The other emission levels were very low against the limit

2.8.6 Test Result of Radiated Spurious Emission Measurement

- (1) The radiation measurement frequency is 9kHz ~ 30MHz. The interference value of this frequency range is less than the limit value of 20 dB. It is considered that the background noise value is not recorded.
- (2) The following table shows the radiation measurement frequency from 30MHz to 26.5GHz, pre-scanning in the X, Y and Z axes. The worst case (X-axis) is documented in this report.

Test Frequency	
RF	BT 1 Mbps / 3 Mbps
Tx	CH00 (2402 MHz)
	CH39 (2441 MHz)
	CH78 (2480 MHz)

Above 1GHz Data

Test Mode :	Transmit BT-BR(1Mbps)	Test Date :	2020/08/18
Test Channel	CH00 (2402 MHz)	Temperature :	25 °C
Polarization :	Horizontal	Relative Humidity :	65 %

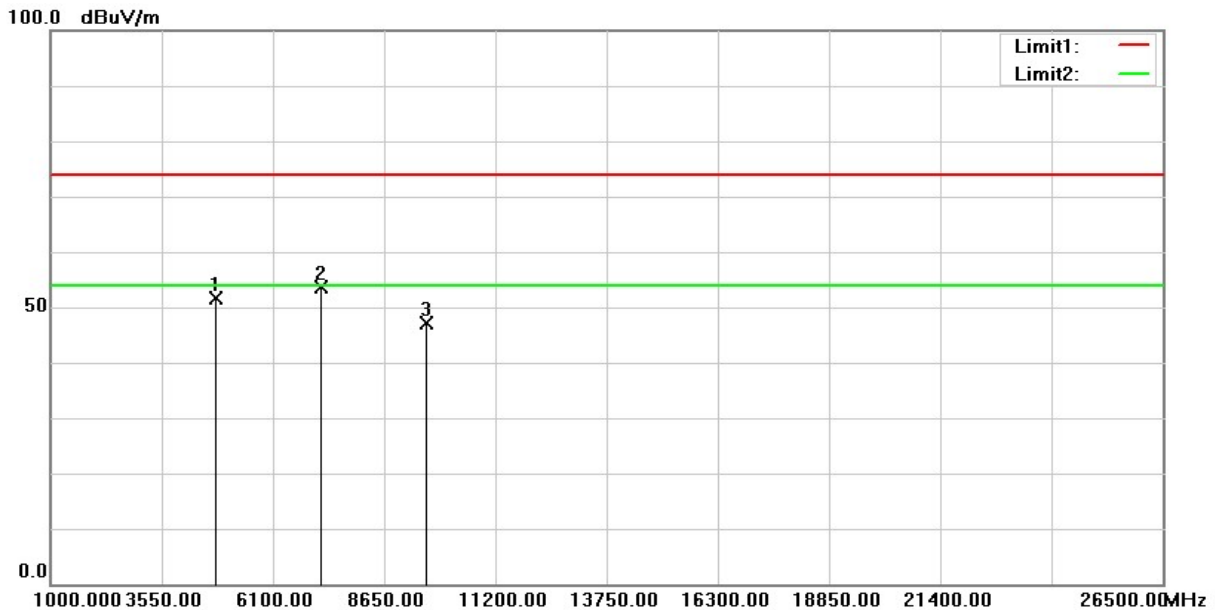

No.	Frequency (MHz)	Reading (dBuV/m)	Correct Factor (dB/m)	Result (dBuV/m)	Limit (dBuV/m)	Margin (dB)	Remark
1	4804.000	72.44	-20.80	51.64	74.00	-22.36	peak
2	7206.000	68.55	-14.83	53.72	74.00	-20.28	peak
3	9608.000	57.26	-10.03	47.23	74.00	-26.77	peak

Remark :

1. Correction Factor = Antenna factor + Cable loss – Amplifier gain
2. Result Value = Reading Level + Correct Factor
3. Margin Level = Result Value – Limit Value
4. The other emission levels were very low against the limit

Test Mode :	Transmit BT-BR(1Mbps)	Test Date :	2020/08/18
Test Channel	CH00 (2402 MHz)	Temperature :	25 °C
Polarization :	Vertical	Relative Humidity :	65 %

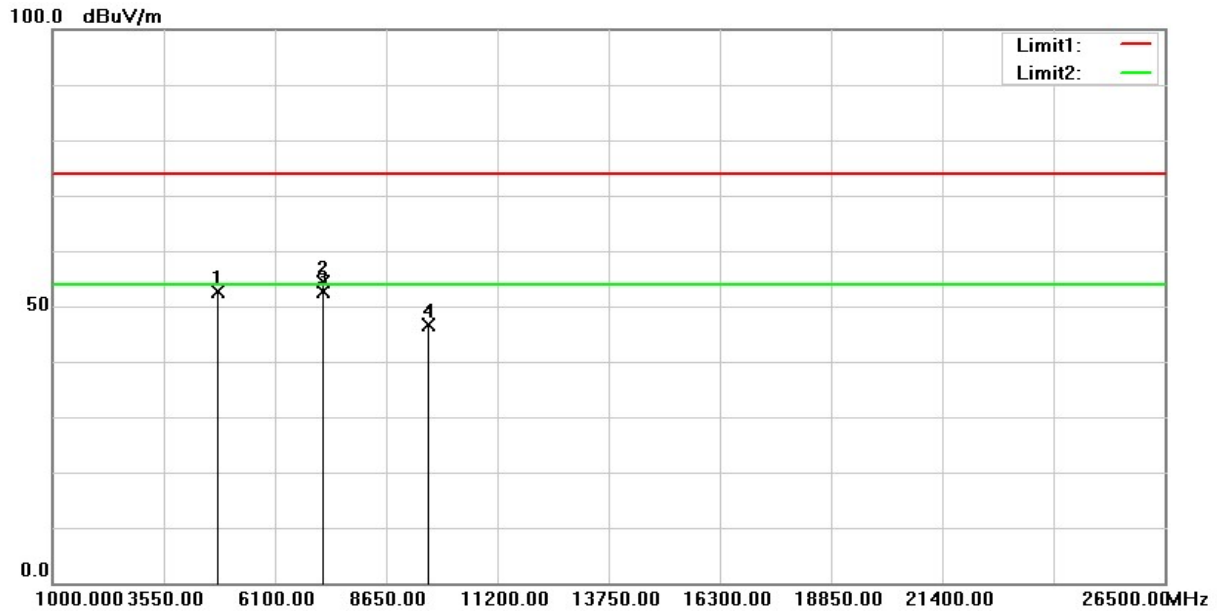

No.	Frequency (MHz)	Reading (dBuV/m)	Correct Factor (dB/m)	Result (dBuV/m)	Limit (dBuV/m)	Margin (dB)	Remark
1	4804.000	73.37	-20.80	52.57	74.00	-21.43	peak
2	7206.000	69.28	-14.83	54.45	74.00	-19.55	peak
3	7206.000	67.42	-14.83	52.59	54.00	-1.41	AVG
4	9608.000	56.74	-10.03	46.71	74.00	-27.29	peak

Remark :

1. Correction Factor = Antenna factor + Cable loss – Amplifier gain
2. Result Value = Reading Level + Correct Factor
3. Margin Level = Result Value – Limit Value
4. The other emission levels were very low against the limit

Test Mode :	Transmit BT-BR(1Mbps)	Test Date :	2020/08/18
Test Channel	CH39 (2441 MHz)	Temperature :	25 °C
Polarization :	Horizontal	Relative Humidity :	65 %

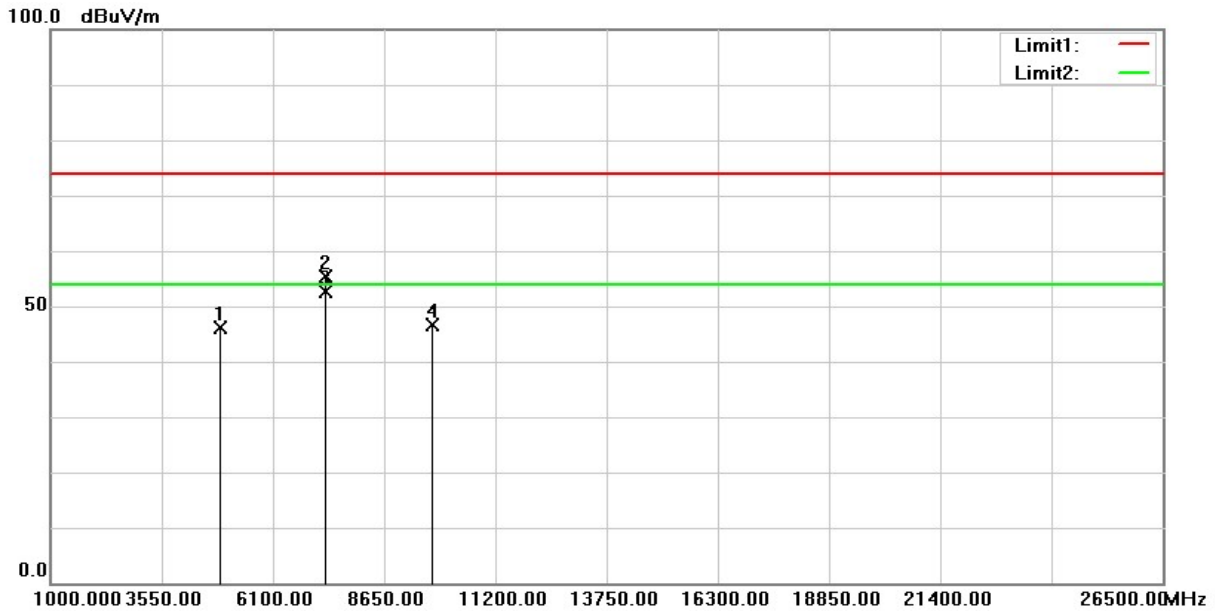

No.	Frequency (MHz)	Reading (dBuV/m)	Correct Factor (dB/m)	Result (dBuV/m)	Limit (dBuV/m)	Margin (dB)	Remark
1	4882.000	67.13	-20.90	46.23	74.00	-27.77	peak
2	7323.000	69.47	-14.08	55.39	74.00	-18.61	peak
3	7323.000	66.66	-14.08	52.58	54.00	-1.42	AVG
4	9764.000	56.32	-9.80	46.52	74.00	-27.48	peak

Remark :

1. Correction Factor = Antenna factor + Cable loss – Amplifier gain
2. Result Value = Reading Level + Correct Factor
3. Margin Level = Result Value – Limit Value
4. The other emission levels were very low against the limit

Test Mode :	Transmit BT-BR(1Mbps)	Test Date :	2020/08/18
Test Channel	CH39 (2441 MHz)	Temperature :	25 °C
Polarization :	Vertical	Relative Humidity :	65 %

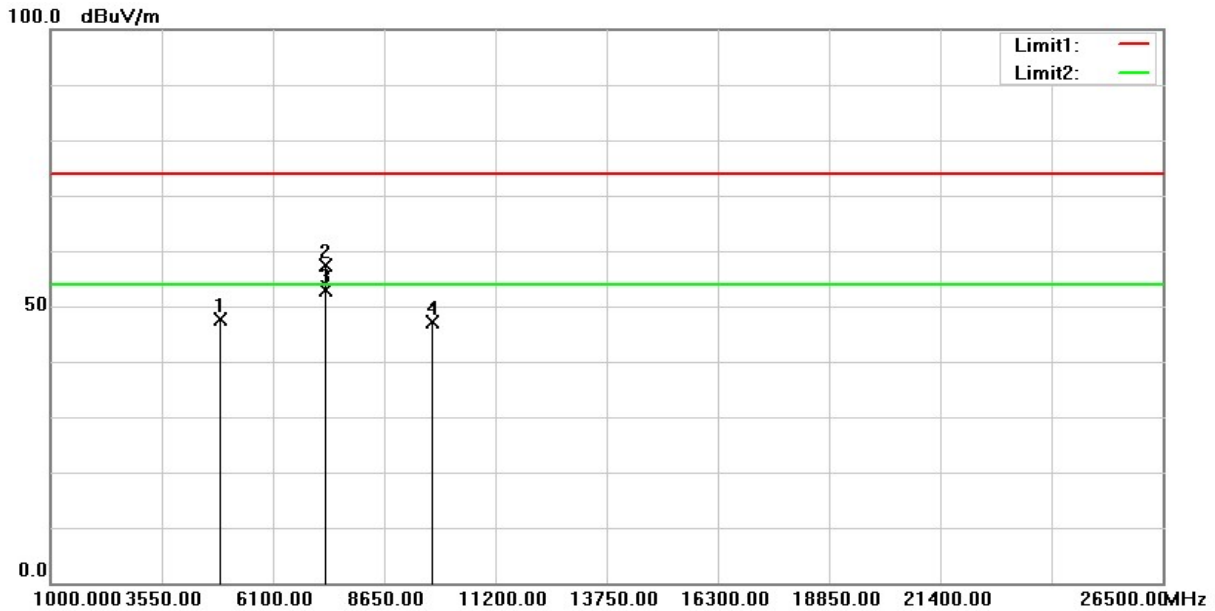

No.	Frequency (MHz)	Reading (dBuV/m)	Correct Factor (dB/m)	Result (dBuV/m)	Limit (dBuV/m)	Margin (dB)	Remark
1	4882.000	68.60	-20.90	47.70	74.00	-26.30	peak
2	7323.000	71.56	-14.08	57.48	74.00	-16.52	peak
3	7323.000	66.99	-14.08	52.91	54.00	-1.09	AVG
4	9764.000	56.98	-9.80	47.18	74.00	-26.82	peak

Remark :

1. Correction Factor = Antenna factor + Cable loss – Amplifier gain
2. Result Value = Reading Level + Correct Factor
3. Margin Level = Result Value – Limit Value
4. The other emission levels were very low against the limit

Test Mode :	Transmit BT-BR(1Mbps)	Test Date :	2020/08/18
Test Channel	CH78 (2480 MHz)	Temperature :	25 °C
Polarization :	Horizontal	Relative Humidity :	65 %

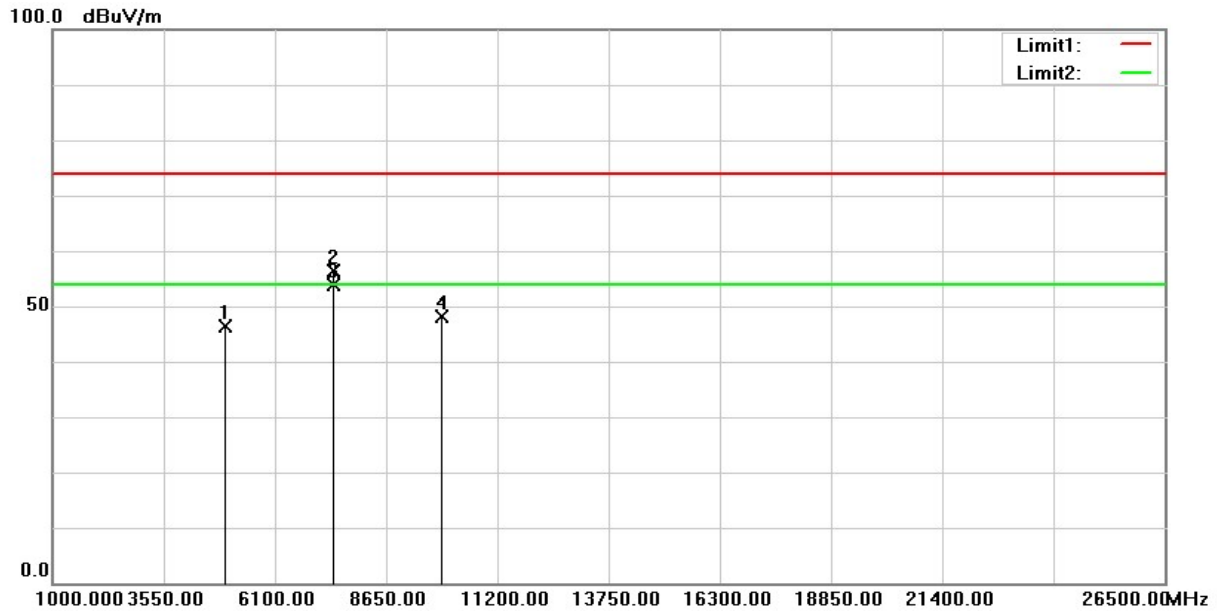

No.	Frequency (MHz)	Reading (dBuV/m)	Correct Factor (dB/m)	Result (dBuV/m)	Limit (dBuV/m)	Margin (dB)	Remark
1	4960.000	67.03	-20.72	46.31	74.00	-27.69	peak
2	7440.000	70.34	-13.88	56.46	74.00	-17.54	peak
3	7440.000	67.68	-13.88	53.80	54.00	-0.20	AVG
4	9920.000	58.03	-9.94	48.09	74.00	-25.91	peak

Remark :

1. Correction Factor = Antenna factor + Cable loss – Amplifier gain
2. Result Value = Reading Level + Correct Factor
3. Margin Level = Result Value – Limit Value
4. The other emission levels were very low against the limit

Test Mode :	Transmit BT-BR(1Mbps)	Test Date :	2020/08/18
Test Channel	CH78 (2480 MHz)	Temperature :	25 °C
Polarization :	Vertical	Relative Humidity :	65 %

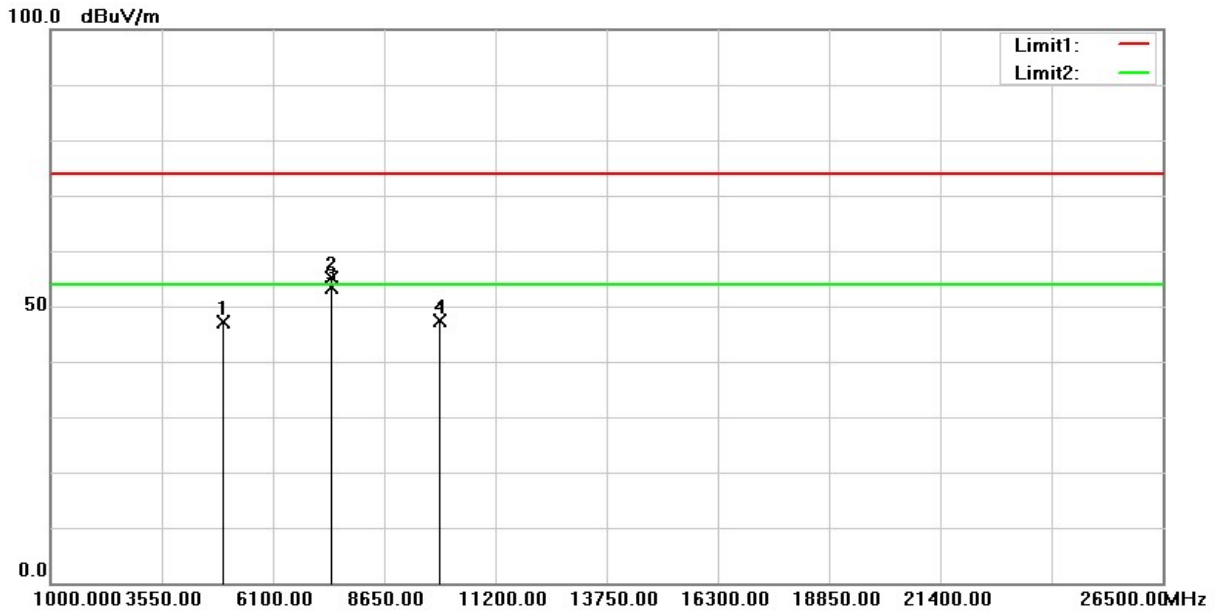

No.	Frequency (MHz)	Reading (dBuV/m)	Correct Factor (dB/m)	Result (dBuV/m)	Limit (dBuV/m)	Margin (dB)	Remark
1	4960.000	67.81	-20.72	47.09	74.00	-26.91	peak
2	7440.000	68.94	-13.88	55.06	74.00	-18.94	peak
3	7440.000	67.17	-13.88	53.29	54.00	-0.71	AVG
4	9920.000	57.42	-9.94	47.48	74.00	-26.52	peak

Remark :

1. Correction Factor = Antenna factor + Cable loss – Amplifier gain
2. Result Value = Reading Level + Correct Factor
3. Margin Level = Result Value – Limit Value
4. The other emission levels were very low against the limit

Test Mode :	Transmit BT-EDR(3Mbps)	Test Date :	2020/08/18
Test Channel	CH00 (2402 MHz)	Temperature :	25 °C
Polarization :	Horizontal	Relative Humidity :	65 %

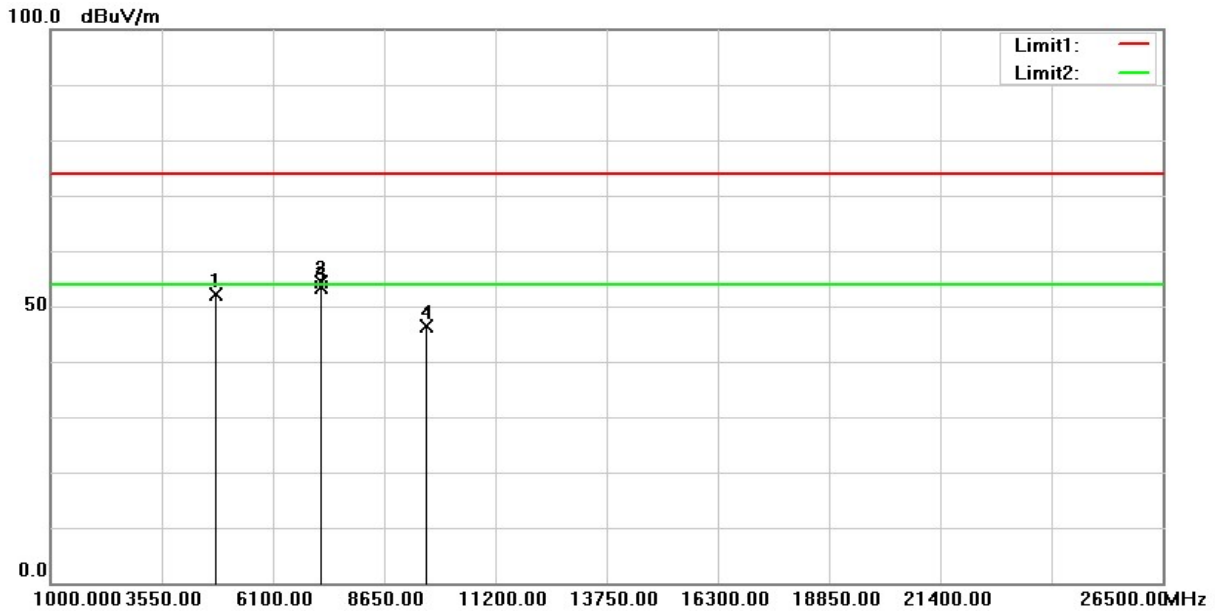

No.	Frequency (MHz)	Reading (dBuV/m)	Correct Factor (dB/m)	Result (dBuV/m)	Limit (dBuV/m)	Margin (dB)	Remark
1	4804.000	73.00	-20.80	52.20	74.00	-21.80	peak
2	7206.000	69.32	-14.83	54.49	74.00	-19.51	peak
3	7206.000	68.15	-14.83	53.32	54.00	-0.68	AVG
4	9608.000	56.52	-10.03	46.49	74.00	-27.51	peak

Remark :

1. Correction Factor = Antenna factor + Cable loss – Amplifier gain
2. Result Value = Reading Level + Correct Factor
3. Margin Level = Result Value – Limit Value
4. The other emission levels were very low against the limit

Test Mode :	Transmit BT-EDR(3Mbps)	Test Date :	2020/08/18
Test Channel	CH00 (2402 MHz)	Temperature :	25 °C
Polarization :	Vertical	Relative Humidity :	65 %

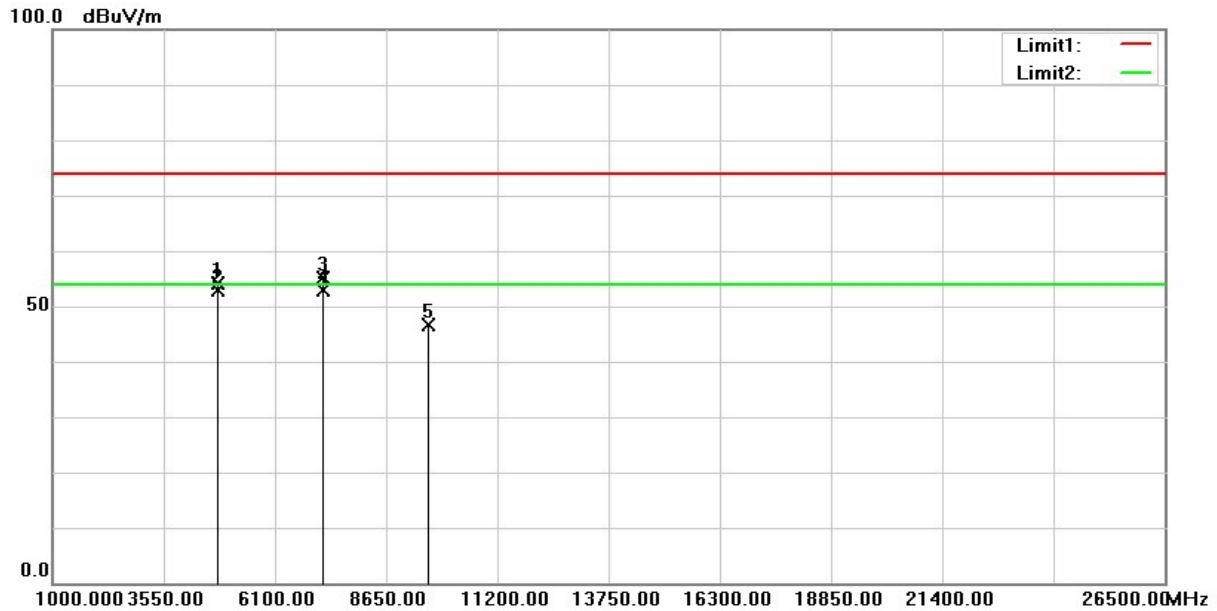

No.	Frequency (MHz)	Reading (dBuV/m)	Correct Factor (dB/m)	Result (dBuV/m)	Limit (dBuV/m)	Margin (dB)	Remark
1	4804.000	74.98	-20.80	54.18	74.00	-19.82	peak
2	4804.000	73.64	-20.80	52.84	54.00	-1.16	AVG
3	7206.000	70.06	-14.83	55.23	74.00	-18.77	peak
4	7206.000	67.60	-14.83	52.77	54.00	-1.23	AVG
5	9608.000	56.67	-10.03	46.64	74.00	-27.36	peak

Remark :

1. Correction Factor = Antenna factor + Cable loss – Amplifier gain
2. Result Value = Reading Level + Correct Factor
3. Margin Level = Result Value – Limit Value
4. The other emission levels were very low against the limit

Test Mode :	Transmit BT-EDR(3Mbps)	Test Date :	2020/08/18
Test Channel	CH39 (2441 MHz)	Temperature :	25 °C
Polarization :	Horizontal	Relative Humidity :	65 %

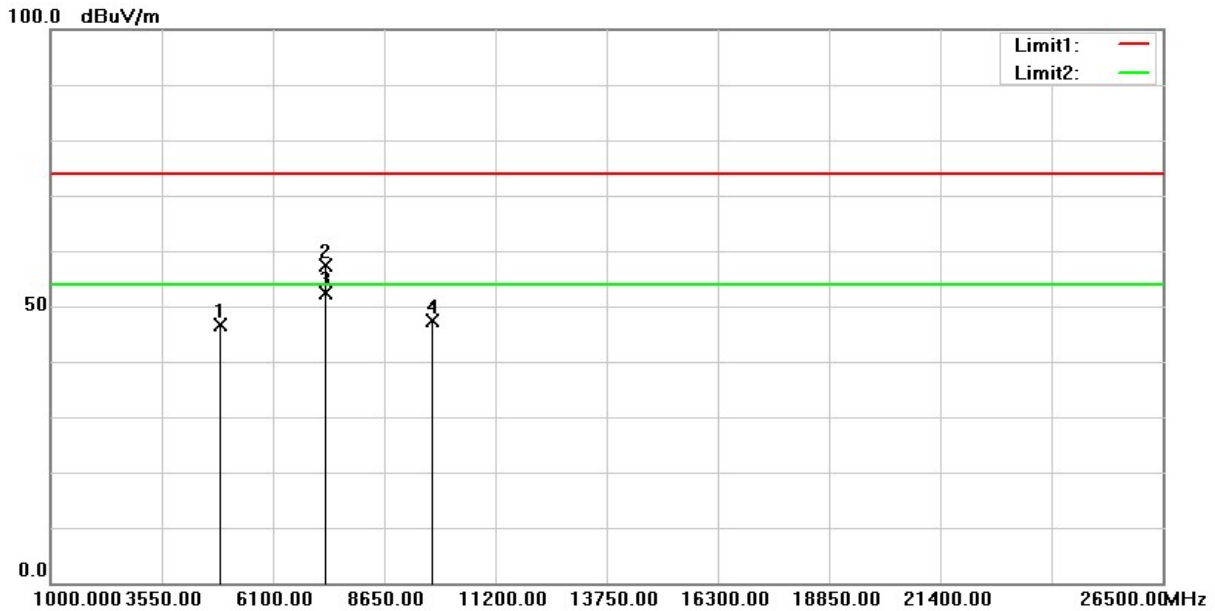

No.	Frequency (MHz)	Reading (dBuV/m)	Correct Factor (dB/m)	Result (dBuV/m)	Limit (dBuV/m)	Margin (dB)	Remark
1	4882.000	67.50	-20.90	46.60	74.00	-27.40	peak
2	7323.000	71.55	-14.08	57.47	74.00	-16.53	peak
3	7323.000	66.56	-14.08	52.48	54.00	-1.52	AVG
4	9764.000	57.12	-9.80	47.32	74.00	-26.68	peak

Remark :

1. Correction Factor = Antenna factor + Cable loss – Amplifier gain
2. Result Value = Reading Level + Correct Factor
3. Margin Level = Result Value – Limit Value
4. The other emission levels were very low against the limit

Test Mode :	Transmit BT-EDR(3Mbps)	Test Date :	2020/08/18
Test Channel	CH39 (2441 MHz)	Temperature :	25 °C
Polarization :	Vertical	Relative Humidity :	65 %

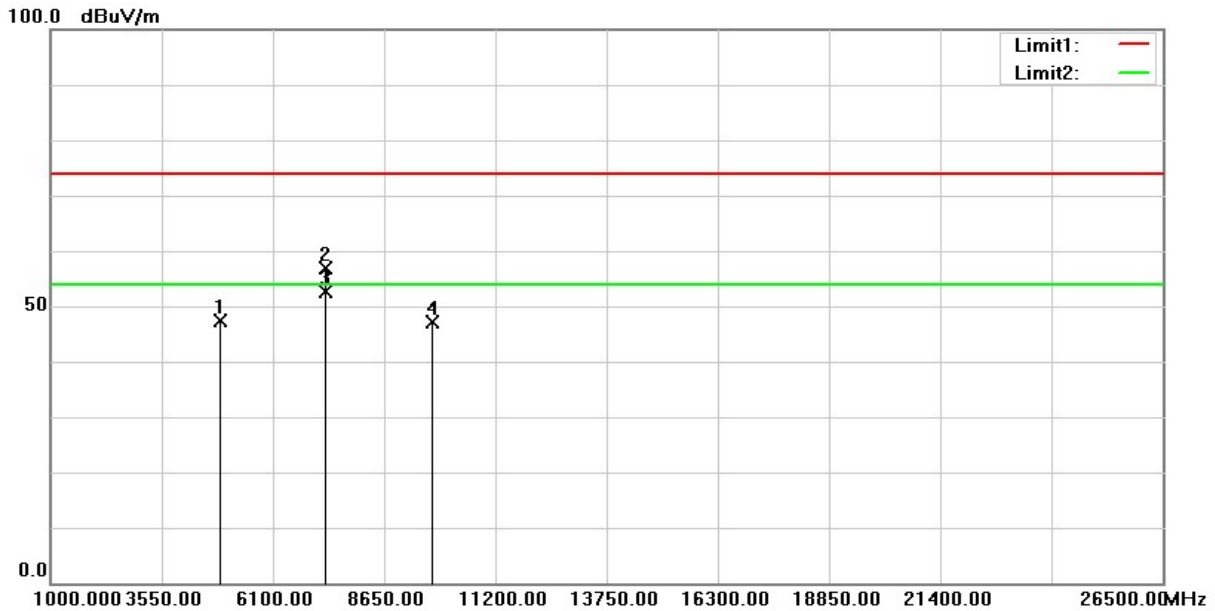

No.	Frequency (MHz)	Reading (dBuV/m)	Correct Factor (dB/m)	Result (dBuV/m)	Limit (dBuV/m)	Margin (dB)	Remark
1	4882.000	68.27	-20.90	47.37	74.00	-26.63	peak
2	7323.000	70.94	-14.08	56.86	74.00	-17.14	peak
3	7323.000	66.83	-14.08	52.75	54.00	-1.25	AVG
4	9764.000	56.82	-9.80	47.02	74.00	-26.98	peak

Remark :

1. Correction Factor = Antenna factor + Cable loss – Amplifier gain
2. Result Value = Reading Level + Correct Factor
3. Margin Level = Result Value – Limit Value
4. The other emission levels were very low against the limit

Test Mode :	Transmit BT-EDR(3Mbps)	Test Date :	2020/08/18
Test Channel	CH78 (2480 MHz)	Temperature :	25 °C
Polarization :	Horizontal	Relative Humidity :	65 %

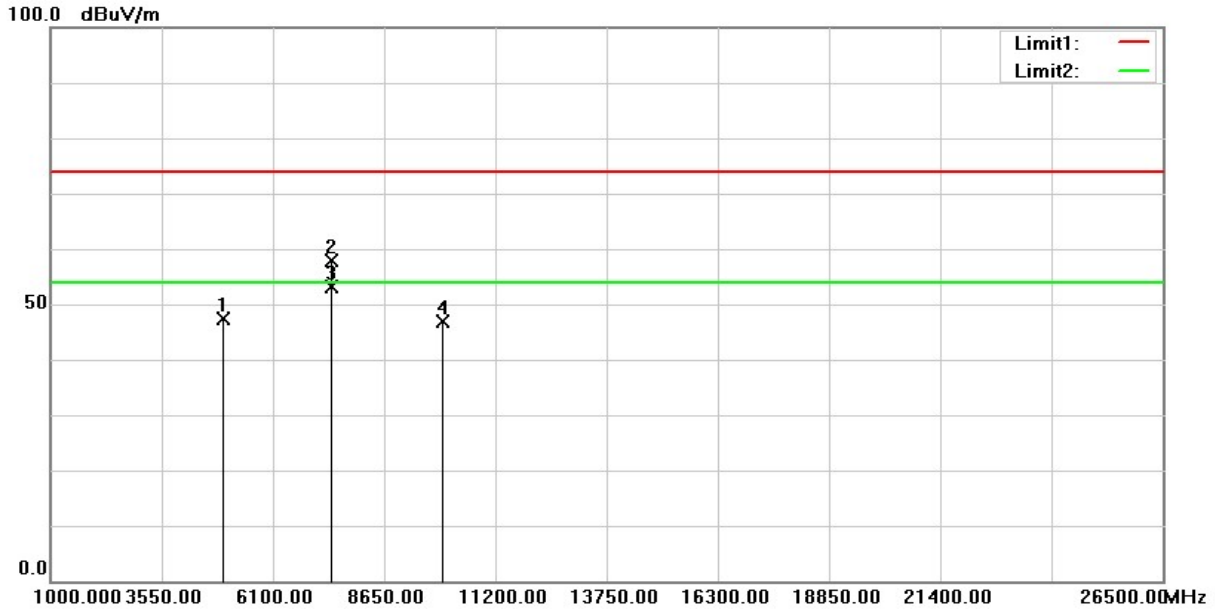

No.	Frequency (MHz)	Reading (dBuV/m)	Correct Factor (dB/m)	Result (dBuV/m)	Limit (dBuV/m)	Margin (dB)	Remark
1	4960.000	68.18	-20.72	47.46	74.00	-26.54	peak
2	7440.000	71.74	-13.88	57.86	74.00	-16.14	peak
3	7440.000	66.96	-13.88	53.08	54.00	-0.92	AVG
4	9960.000	57.05	-10.10	46.95	74.00	-27.05	peak

Remark :

1. Correction Factor = Antenna factor + Cable loss – Amplifier gain
2. Result Value = Reading Level + Correct Factor
3. Margin Level = Result Value – Limit Value
4. The other emission levels were very low against the limit

Test Mode :	Transmit BT-EDR(3Mbps)	Test Date :	2020/08/18
Test Channel	CH78 (2480 MHz)	Temperature :	25 °C
Polarization :	Vertical	Relative Humidity :	65 %

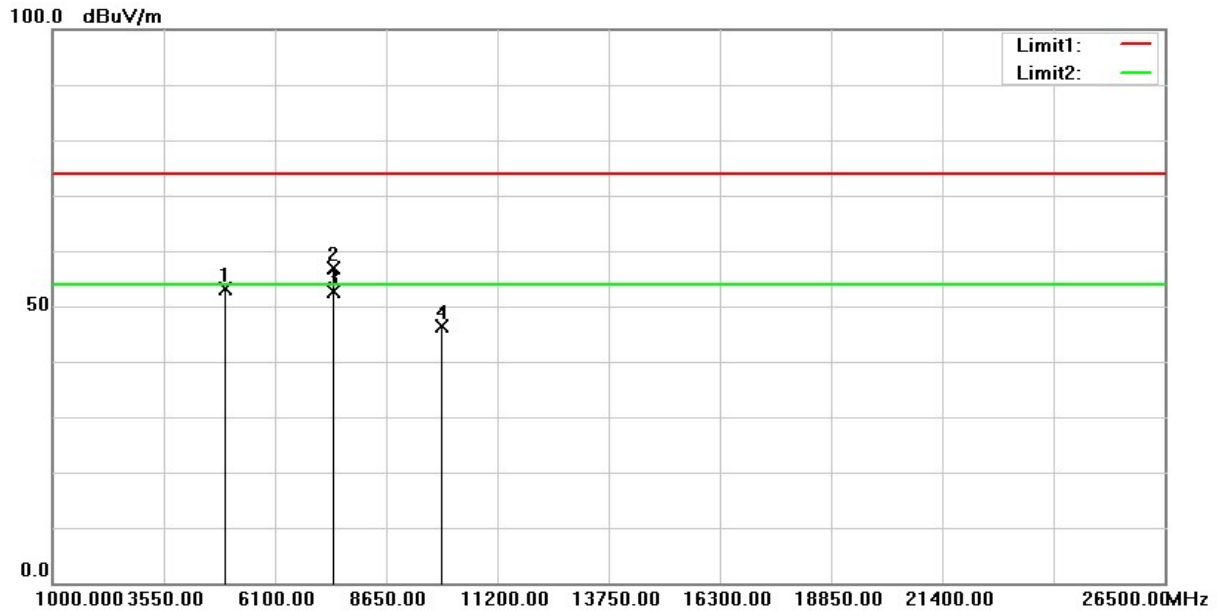

No.	Frequency (MHz)	Reading (dBuV/m)	Correct Factor (dB/m)	Result (dBuV/m)	Limit (dBuV/m)	Margin (dB)	Remark
1	4960.000	73.85	-20.72	53.13	74.00	-20.87	peak
2	7440.000	70.85	-13.88	56.97	74.00	-17.03	peak
3	7440.000	66.50	-13.88	52.62	54.00	-1.38	AVG
4	9920.000	56.39	-9.94	46.45	74.00	-27.55	peak

Remark :

1. Correction Factor = Antenna factor + Cable loss – Amplifier gain
2. Result Value = Reading Level + Correct Factor
3. Margin Level = Result Value – Limit Value
4. The other emission levels were very low against the limit

Below 1GHz Data

Test Mode :	Transmit BT	Test Date :	2020/08/17
Test Channel	CH39 (2441 MHz)	Temperature :	25 °C
Polarization :	Horizontal	Relative Humidity :	65 %

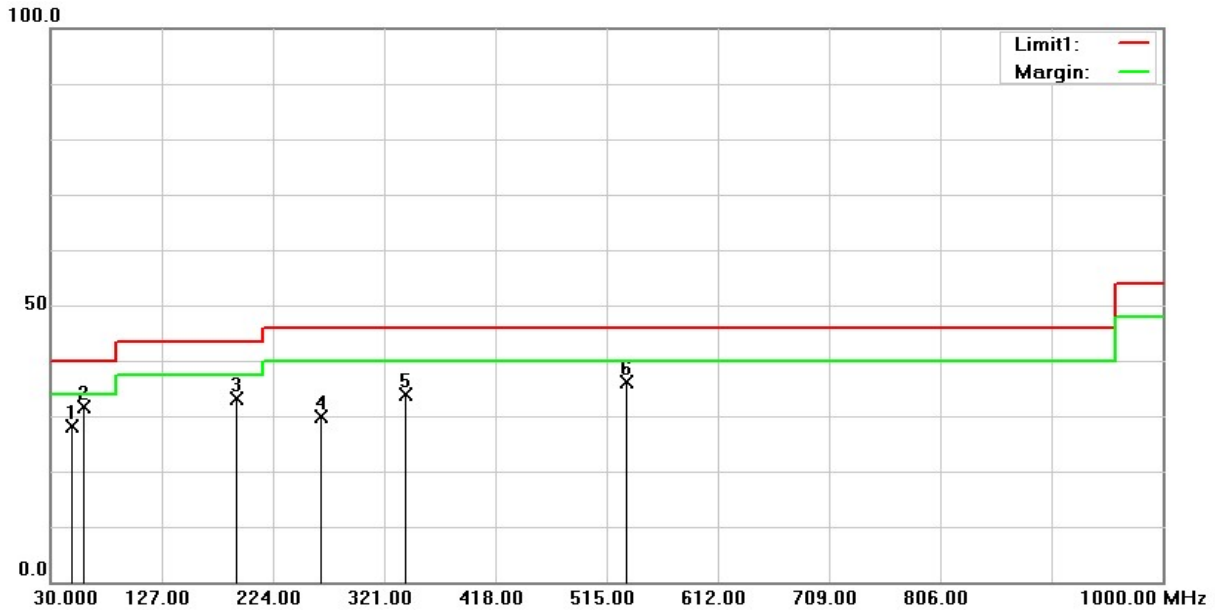

No.	Frequency (MHz)	Reading (dBuV/m)	Correct Factor (dB/m)	Result (dBuV/m)	Limit (dBuV/m)	Margin (dB)	Remark
1	48.4300	37.62	-9.60	28.02	40.00	-11.98	QP
2	59.1000	42.30	-10.58	31.72	40.00	-8.28	QP
3	191.9900	44.37	-11.22	33.15	43.50	-10.35	QP
4	265.7100	39.85	-9.91	29.94	46.00	-16.06	QP
5	339.4300	42.30	-8.46	33.84	46.00	-12.16	QP
6	532.4600	40.16	-4.13	36.03	46.00	-9.97	QP

Remark :

1. Correction Factor = Antenna factor + Cable loss – Amplifier gain
2. Result Value = Reading Level + Correct Factor
3. Margin Level = Result Value – Limit Value
4. The other emission levels were very low against the limit

Test Mode :	Transmit BT	Test Date :	2020/08/17
Test Channel	CH39 (2441 MHz)	Temperature :	25 °C
Polarization :	Vertical	Relative Humidity :	65 %

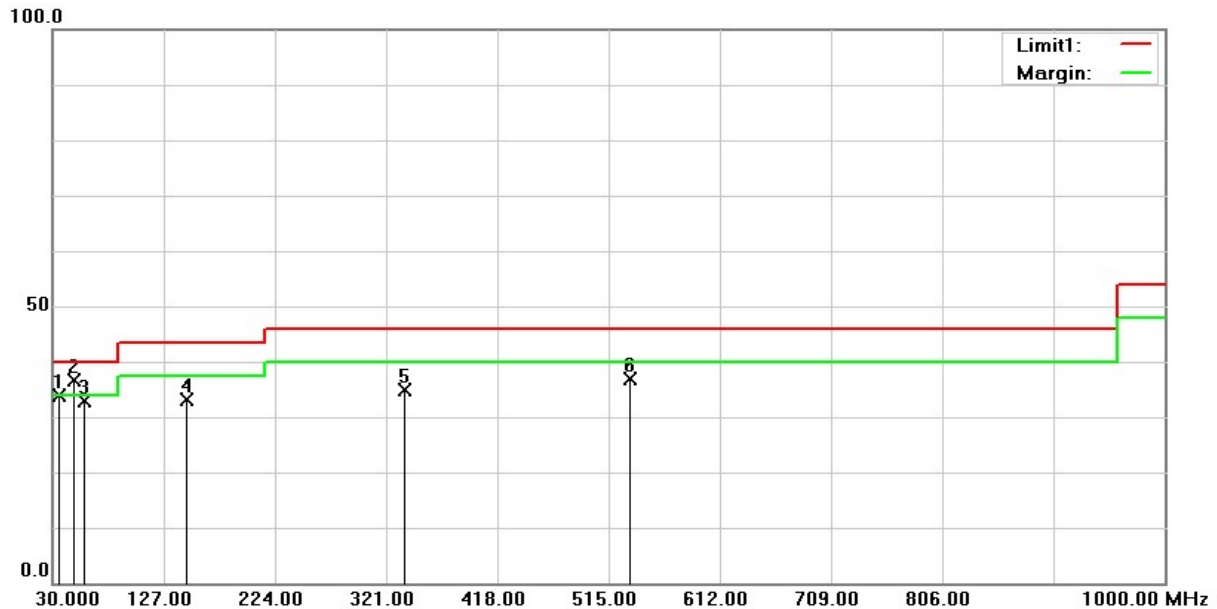

No.	Frequency (MHz)	Reading (dBuV/m)	Correct Factor (dB/m)	Result (dBuV/m)	Limit (dBuV/m)	Margin (dB)	Remark
1	35.8200	44.64	-10.66	33.98	40.00	-6.02	QP
2	48.4300	46.21	-9.60	36.61	40.00	-3.39	QP
3	58.1300	43.44	-10.48	32.96	40.00	-7.04	QP
4	147.3700	43.11	-10.09	33.02	43.50	-10.48	QP
5	337.4900	43.29	-8.51	34.78	46.00	-11.22	QP
6	533.4300	41.10	-4.11	36.99	46.00	-9.01	QP

Remark :

1. Correction Factor = Antenna factor + Cable loss – Amplifier gain
2. Result Value = Reading Level + Correct Factor
3. Margin Level = Result Value – Limit Value
4. The other emission levels were very low against the limit

2.9 AC Conducted Emissions Measurement

2.9.1 Limit

Frequency (MHz)	FCC Part 15 Subpart C Paragraph 15.207 (dB μ V) Limit	
	Quasi-peak	Average
0.15 to 0.5	66 to 56*	56 to 46*
0.50 to 5.0	56	46
5.0 to 30.0	60	50

*Decreases with the logarithm of the frequency

2.9.2 Test Setup

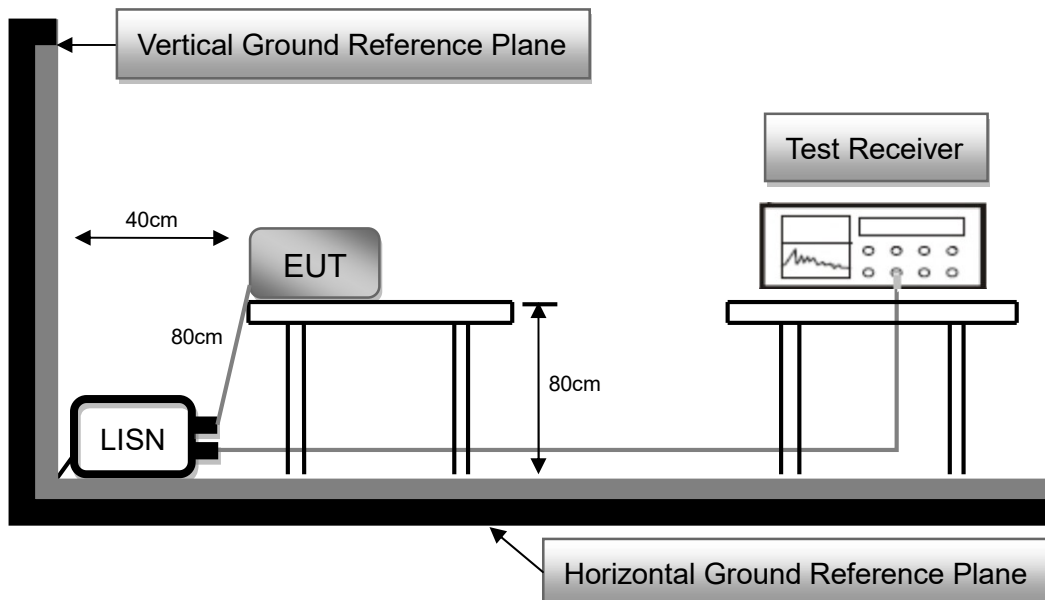

2.9.3 Test Procedure

1. The EUT was placed 0.8 meter height wooden table from the horizontal ground plane with EUT being connected to power source through a line impedance stabilization network (LISN). The LISN at least be 80 cm from nearest chassis of EUT.
2. The line impedance stabilization network (LISN) provides 50 ohm/50uH of coupling impedance for the measuring instrument. All other support equipments powered from additional LISN(s).
3. Interrelating cables that hang closer than 40 cm to the ground plane shall be folded back and forth in the center forming a bundle. All I/O cables were positioned to simulate typical usage.
4. All I/O cables that are not connected to a peripheral shall be bundle in the center. The end of the cable may be terminated, if required, using the correct terminating impedance. The overall length shall not exceed 1 m.
5. The EMI test receiver connected to LISN powering the EUT. The actual test configuration, please refer to EUT test photos.
6. The receiver scanned from 150kHz to 30MHz for emissions in each of test modes. A scan was taken on both power lines, Line and Neutral, recording at least six highest emissions.
7. The EUT and cable configuration of the above highest emission levels were recorded. The test data of the worst case was recorded.

2.9.4 Test Result

Owing to the DC operation of EUT, this test item is not performed.

--- END ---