

# **BTA-C1024-3M**

## **User Manual**

**Issued date: May 21, 2018**

## EnzyTek Bluetooth® Low Energy Module With on Board Antenna

### BTA-C1024-3M



### OVERVIEW

Highly integration BT 4.2 Low Energy module, CSR1024 + Filter + X'Tal + PCB Antenna. + Metal shielding case.

Wireless communications module conforming to Bluetooth Version 4.2.

UART, SPI interfaces available to various applications.

15 GPIO ports available for user's application.

1 Analog IO ports available for user's application.

BT Chipset	: CSR CSR1024
- Standards	: Bluetooth 4.2 Low Energy.
Frequency	: 2402 ~ 2480 MHz
- RX Sensitivity	: <b>-87</b> dBm (min)
Range	: > 10 m (line-of-sight at open space)
Memory	: on chip Flash memory (256K Bits)
Operation Voltage	: 1.8V ~ 3.6V
Dimension	: 18 x 13 x <b>2.7</b> <sub>(max)</sub> mm <sup>3</sup> (LxWxH)
Environmental Range	: Operation Temperature : -20~+85°C, Relative humidity : 0~95%

**Pinout Diagram / Dimension**

Unit : mm

Note: Please contact EnzyTek to get the detail footprint of the module to do the PCB design.

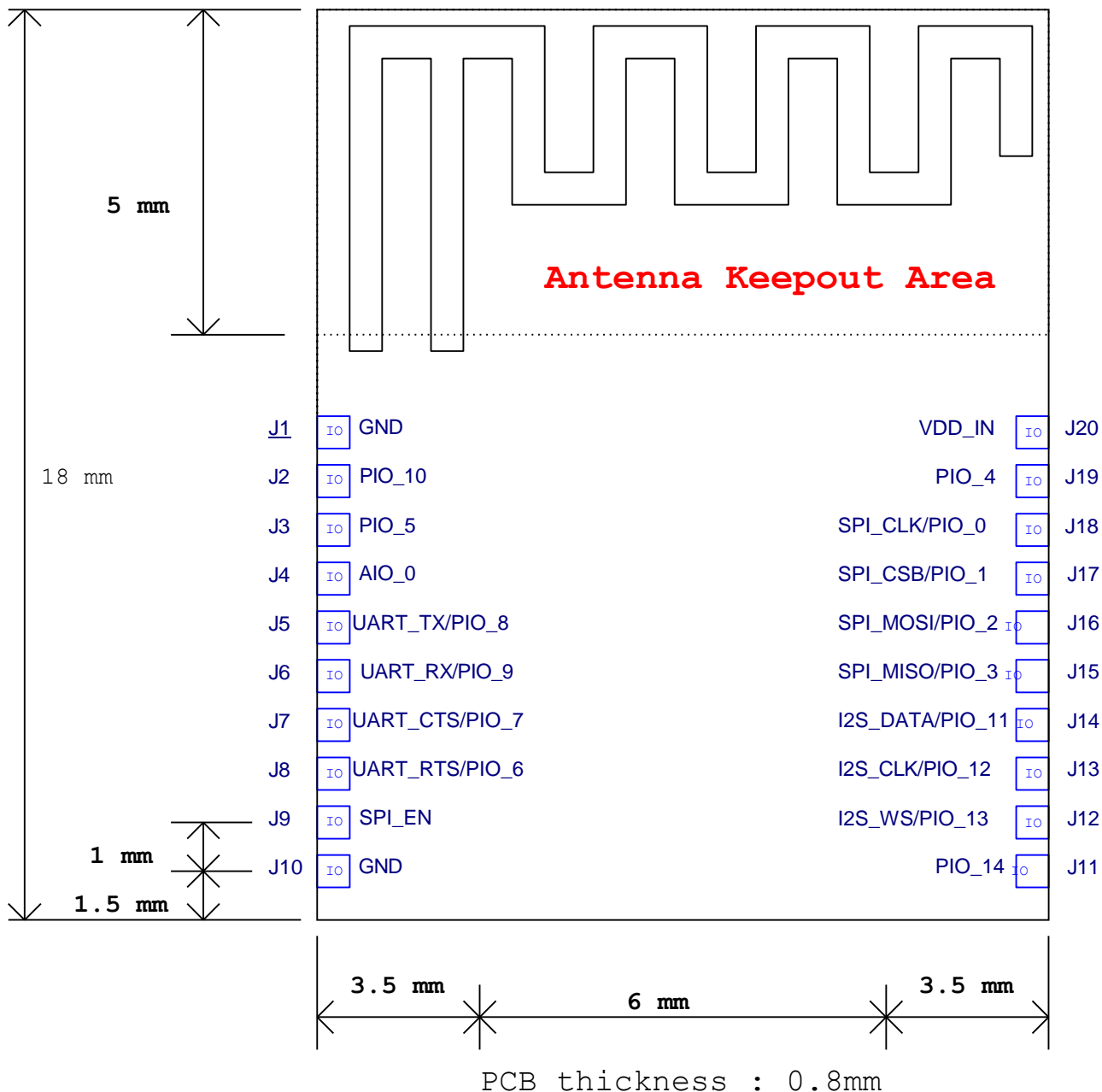

## I/O PIN LISTING

Pin No.	Pin Name	Type	Description
J1	GND	Power	Ground
J2	PIO_10	Bi-directional with programmable strength internal pull-up/down	Programmable input/output line 10
J3	PIO_5	Bi-directional with programmable strength internal pull-up/down	Programmable input/output line 5
J4	AIO_0	Analog bi-directional	Programmable input/output line
J5	UART_TX/PIO_8	Bi-directional with programmable strength internal pull-up/down	UART data output t, optional PIO8 which is defined by FW.
J6	UART_RX/PIO_9	Bi-directional with programmable strength internal pull-up/down	UART data input, optional PIO9 which is defined by FW.
J7	UART_CTS/PIO_7	Bi-directional with programmable strength internal pull-up/down	Programmable input/output line 7
J8	UART_RTS/PIO_6	Bi-directional with programmable strength internal pull-up/down	Programmable input/output line 6
J9	SPI_EN	Input with internal pull-down	Enable SPI interface for debug SPI on PIO[3:0].
J10	GND	Power	Ground
J11	PIO_14	Bi-directional with programmable strength internal pull-up/down	Programmable input/output line 14
J12	I2S_WS/PIO_13	Bi-directional with programmable strength internal pull-up/down	Programmable input/output line 13
J13	I2S_CLK/PIO_12	Bi-directional with programmable strength internal pull-up/down	Programmable input/output line 12
J14	I2S_DATA/PIO_11	Bi-directional with programmable strength internal pull-up/down	Programmable input/output line 11
J15	SPI_MISO/PIO_3	Bi-directional with programmable strength internal pull-up/down	Programmable input/output line 3
J16	SPI_MOSI/PIO_2	Bi-directional with programmable strength internal pull-up/down	Programmable input/output line 2
J17	SPI_CSB/PIO_1	Bi-directional with programmable strength internal pull-up/down	Programmable input/output line 1
J18	SPI_CLK/PIO_0	Bi-directional with programmable strength internal pull-up/down	Programmable input/output line 0

J19	PIO_4	Bi-directional with programmable strength internal pull-up/down	Programmable input/output line 4
J20	VDD_IN	Power	3.3V input

**Electrical Characteristics****Absolute Maximum Ratings :**

	<b>Min.</b>	<b>Typ.</b>	<b>Max.</b>	<b>Unit</b>
Supply Voltage	0	-	3.6	V
Storage Temperature	-20	-	85	°C

**Recommend Operation Conditions :**

	<b>Min.</b>	<b>Typ.</b>	<b>Max.</b>	<b>Unit</b>
Supply Voltage	1.8	-	3.6	V
Operating Temperature	0	-	85	°C

**Input/Output Terminal Characteristics :**

	<b>Min.</b>	<b>Typ.</b>	<b>Max.</b>	<b>Unit</b>
Digital (UART, PIO)				
V <sub>IL</sub> Input Voltage Low		-	0.25xVDD	V
V <sub>IH</sub> Input Voltage High	0.75xVDD	-		V
V <sub>OL</sub> Output Voltage Low, (I <sub>o</sub> is 4mA)	-	-	0.2xVDD	V
V <sub>OH</sub> Output Voltage High, (I <sub>o</sub> is -4mA)	0.8xVDD	-	-	V

## Radio Characteristics

VCC = 3.3V

	Min	Typ	Max	Limits(BLE SPEC)	Unit
Output Power					
Min Power	-20			>-20	dBm
Peak to Average		0		<3	dBm
Carrier drift					
Fn	-150		150	<=150	kHz
Drift rate	-20		20	<20	kHz/50us
Max Power	-50		50	<50	kHz
Modulation Characteristic					
F1avg,'F1max'	225		275	225<= <=275	kHz
F2avg,'F2max'	185			>=185	kHz
F1/F2 Ratio		0.8		>=0.8	
Sensitivity (-87dBm)					
Frame Error Rate	0		30.8	<=30.8(-70dBm)	%
PER Integrity					
Frame Error Rate	50		65.4	50<= <=65.4	%
Max Input Power					
Frame Error Rate		0		<=30.8(-40dBm)	%

**Current Consumption**

HW	BTA-C1024-3	
FW version	TBD	
FW configuration	Role	Gatt Server, device side
	Service	SPS Service
	Baud Rate	2400
	Default Power	Scale 0
BT BLE Host	iPhone 4S (ios5)	
Current Meter	Fluke 189	

	Min.	Avg.	Max.
Power On No connection	TBD	TBD	TBD
Power On advertising	TBD	TBD	TBD
Connected No Data Transfer	TBD	TBD	TBD
Connected TX Data/sec (from module to host)	TBD	TBD	TBD
Connected TX Data/500ms (from module to host)	TBD	TBD	TBD



# PCB Layout Guide

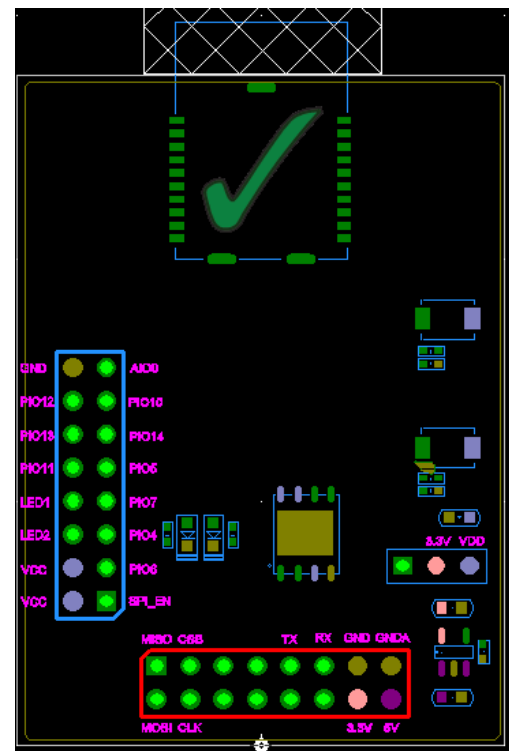
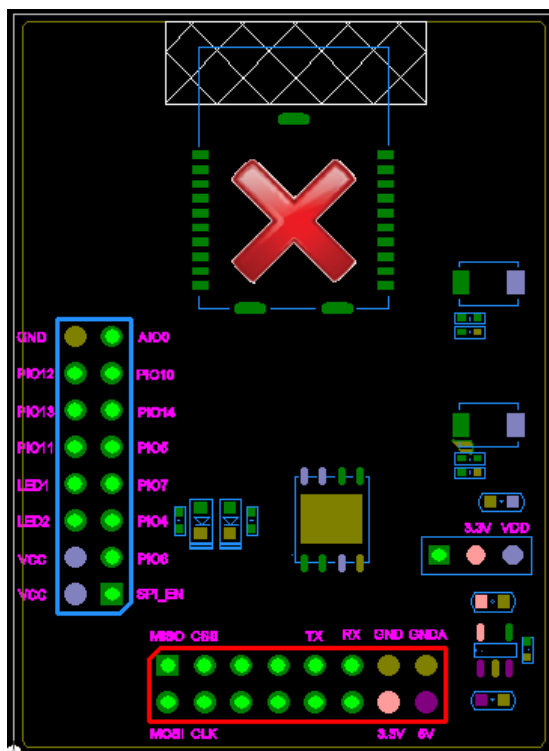
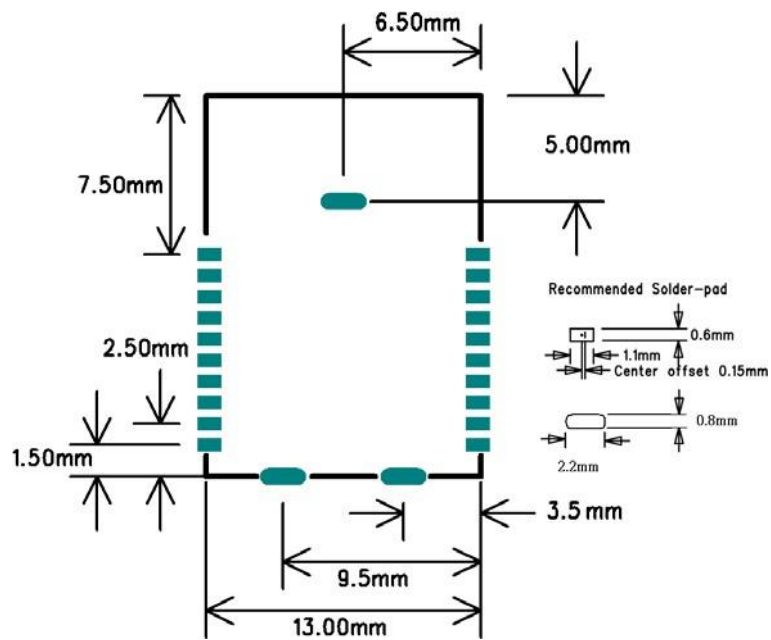

## **FCC Warning**

The final end product must be labeled in a visible area with the following: "Contains FCC ID: 2AABGC1024-3M". The equipment complies with FCC RF exposure limits set forth for an uncontrolled environment. The equipment must not be co-located or operating in conjunction with any other antenna or transmitter.

### Information for the OEMs and Integrators

The following statement must be included with all versions of this document supplied to an OEM or integrator, but should not be distributed to the end user.

- 1) This device is intended for OEM integrators only.
- 2) Please see the full Grant of Equipment document for other restrictions.

This device complies with part 15 of the FCC Rules. Operation is subject to the following two conditions: (1) This device may not cause harmful interference, and (2) this device must accept any interference received, including interference that may cause undesired operation.

## **NCC Warning**

根據低功率電波輻射性電機管理辦法：

第十二條 經型式認證合格之低功率射頻電機，非經許可，公司、商號或使用者均不得擅自變更頻率、加大功率或變更原設計之特性及功能。

第十四條 低功率射頻電機之使用不得影響飛航安全及干擾合法通信；經發現有干擾現象時，應立即停用，並改善至無干擾時方得繼續使用。前項合法通信，指依電信法規定作業之無線電通信。低功率射頻電機須忍受合法通信或工業、科學及醫療用電波輻射性電機設備之干擾。

本模組於取得認證後將依規定於模組本體標示審驗合格標籤，並要求最終產品平台廠商(OEM Integrator)於最終產品平台(End Product)上標示” 本產品內含射頻模組，其 NCC 型式認證號碼為：  CCXXxxYYyyyZzW “