

CERTIFICATION TEST REPORT FOR

FCC ID: 2AAB7WGM1
IC : 12247A-WGM1

Report Reference No.....: 13EAB08034 11

Date of issue.....: 2014-8-7

Testing Laboratory.....: ATT Product Service Co., Ltd.

Address.....: No. 3, ChangLianShan Industrial Park, ChangAn Town,
DongGuan City, GuangDong, China.

Applicant's name: Sintai Optical(Shenzhen)Co.,Ltd

Address.....: Qiwei Ind Sec, 1st, 2nd, &3Rd Bldg, Li-Song-Lang, Bao'an
District, Gong-Ming Town, Shenzhen, Guangdong, China

Manufacturer.....: Sintai Optical(Shenzhen)Co.,Ltd

Address.....: Qiwei Ind Sec, 1st, 2nd, &3Rd Bldg, Li-Song-Lang, Bao'an
District, Gong-Ming Town, Shenzhen, Guangdong, China

Test specification:

Test item description: Digital Camera

Trade Mark: RICOH

Model/Type reference: RICOH WG-M1

Ratings.....: Rechargeable Battery 3.6V1250mAh, 4.5Wh or
5Vd.c 1000mA via adapter (Adapter model:GAC-03-US,
Input:AC100-240V 50/60Hz 0.15A;output: DC5.0V)

Responsible Engineer

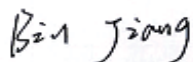

(Bin Jiang/ Engineer)

Approved by



(Tomy Wu /EMC Manager)

TABLE OF CONTENTS

TEST REPORT DECLARE	4
1.Summary of test Standards and results.....	5
2.General test information	6
2.1 Accreditations	6
2.2 Description of EUT.....	6
2.3 Accessories of EUT	6
2.4 Assistant equipment used for test	6
2.5 Block diagram of EUT configuration for test	7
2.6 Test environment conditions	7
2.7 Measurement uncertainty	7
3. 6dB Bandwidth and 99% Occupied Bandwidth	8
3.1 Test equipment.....	8
3.2 Block diagram of test setup	8
3.3 Limits.....	8
3.4 Test Procedure.....	8
3.5 Test Result.....	8
3.6 Original test data	9
4. Maximum Peak Output Power	14
4.1 Test equipment	14
4.2 Block diagram of test setup.....	14
4.3 Limits	14
4.4 Test Procedure	14
4.5 Test Result	14
5. Power Spectral Density	15
5.1 Test equipment	15
5.2 Block diagram of test setup.....	15
5.3 Limits	15
5.4 Test Procedure	15
5.5 Test Result	16
5.6 Original test data.....	16
6. Spurious Emissions	21
6.1 Test equipment	21
6.2 Block diagram of test setup.....	21
6.3 Limit	22
6.4 Test Procedure	23
6.5 Test result	24

7. 100 kHz Bandwidth of Frequency Band Edge.....	31
7.1 Test equipment.....	31
7.2 Block diagram of test setup	31
7.3 Limit.....	31
7.4 Test Procedure.....	32
7.5 Test result	32
8. Power Line Conducted Emission.....	36
8.1 Test equipment.....	36
8.2 Block diagram of test setup	36
8.3 Power Line Conducted Emission Limits(Class B).....	36
8.4 Test Procedure.....	36
8.5 Test Result	37
9. Conducted Spurious Emissions.....	39
9.1. Test Equipment.....	39
9.2. Limit	40
9.3. Test Procedure	40
9.4. Test result.....	40
10. Antenna Requirements.....	45
10.1 Limit.....	45
10.2 Result.....	45

TEST REPORT DECLARE

Applicant	:	Sintai Optical(Shenzhen)Co.,Ltd
Address	:	Qiwei Ind Sec, 1st, 2nd, &3Rd Bldg, Li-Song-Lang, Bao'an District, Gong-Ming Town, Shenzhen, Guangdong, China
Equipment under Test	:	Digital Camera
Model No	:	RICOH WG-M1
Trade Mark	:	RICOH
Manufacturer	:	Sintai Optical(Shenzhen)Co.,Ltd
Address	:	Qiwei Ind Sec, 1st, 2nd, &3Rd Bldg, Li-Song-Lang, Bao'an District, Gong-Ming Town, Shenzhen, Guangdong, China

Test Standard Used: FCC Rules and Regulations Part 15 Subpart C

RSS 210, ISSUE 8

Test procedure used: ANSI C63.10:2009, ANSI C63.4:2009, KDB558074 D01 DTS Meas Guidance V03r02

We Declare:

The equipment described above is tested by ATT Product Service Co., Ltd. and in the configuration tested the equipment complied with the standards specified above. The test results are contained in this test report and ATT Product Service Co., Ltd. is assumed of full responsibility for the accuracy and completeness of these tests.

After test and evaluation, our opinion is that the equipment provided for test compliance with the requirement of the above FCC standards.

Report No:	13EAB08034 11		
Date of Test:	2014-7-23---2014-8-4	Date of Report:	2014-8-7

Note: This report applies to above tested sample only. This report shall not be reproduced in parts without written approval of ATT Product Service Co., Ltd.

1.Summary of test Standards and results

The EUT have been tested according to the applicable standards as referenced below.

Description of Test Item	Standard	Results
6dB Bandwidth And 99% Occupied Bandwidth	§ 15.247 (a)(2) RSS 210, ISSUE 8	PASS
Peak Output Power	§ 15.247(b)(3) RSS 210, ISSUE 8	PASS
Power Spectral Density	§ 15.247(e) RSS 210, ISSUE 8	PASS
Spurious Emissions at Antenna Port	§ 15.247(d) RSS 210, ISSUE 8	PASS
Spurious Emissions	§ 15.205, §15.209, §15.247(d) RSS 210, ISSUE 8	PASS
100 kHz Bandwidth of Frequency Band Edge	§ 15.247(d) RSS 210, ISSUE 8	PASS
AC Line Conducted Emissions	§ 15.207 (a) RSS 210, ISSUE 8	PASS
Antenna requirement	FCC Part 15: 15.203 RSS 210, ISSUE 8	PASS

2.General test information

2.1 Accreditations

The measuring facility of laboratories has been authorized or registered by the following approval agencies.

USA **FCC** **Registration Number :923232**
Canada **INDUSTRY CANADA** **Registration Number 11033A**

2.2 Description of EUT

EUT* Name	:	Digital Camera
Model Number	:	RICOH WG-M1
Trade Mark	:	
EUT function description	:	Please reference user manual of this device
Power supply	:	DC 3.6V
Radio Specification	:	IEEE802.11b/g/n
Operation frequency	:	IEEE 802.11b: 2412MHz—2462MHz IEEE 802.11g: 2412MHz—2462MHz IEEE 802.11n HT20: 2412MHz—2462MHz
Modulation	:	IEEE 802.11b: DSSS(CCK,DQPSK,DBPSK) IEEE 802.11g: OFDM(64QAM, 16QAM, QPSK, BPSK) IEEE 802.11n HT20: OFDM (64QAM, 16QAM, QPSK,BPSK)
Antenna Type	:	built-in antenna, maximum PK gain:3dBi
Date of Receipt	:	2014-8-4
Sample Type	:	Series production

Note: EUT is the ab. of equipment under test.

2.3 Accessories of EUT

Description of Accessories	Manufacturer	Model number or Type	Other
AC ADAPTOR	SHENZHEN CYCLELONG POWER.TECH CO.,LTD	GAC-03-US	FCC VOC
DC Battery	RICOH	DB-65	/
USB Cable	RICOH	/	/

2.4 Assistant equipment used for test

Description of Assistant equipment	Manufacturer	Model number or Type	Other
PC	Lenovo	E R500	FCC DOC

2.5 Block diagram of EUT configuration for test

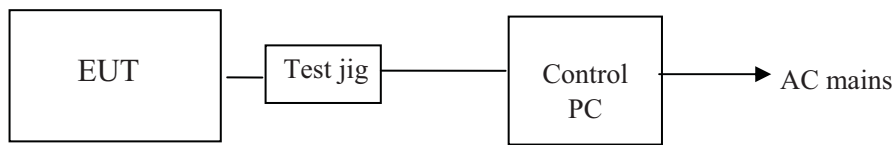

EUT was connected to control to a special test jig provided by manufacturer which has a standard RSS-232 connector to connect to Notebook, and the Notebook will run a special test software “MP_v1.1.1” provided by manufacturer to control EUT work in test mode as blow table.

Tested mode, channel, and data rate information			
Mode	data rate (Mbps) (see Note)	Channel	Frequency (MHz)
IEEE 802.11b	1	Low :CH1	2412
	1	Middle: CH6	2437
	1	High: CH11	2462
IEEE 802.11g	6	Low :CH1	2412
	6	Middle: CH6	2437
	6	High: CH11	2462
IEEE 802.11n HT20	MCS 0	Low :CH1	2412
	MCS 0	Middle: CH6	2437
	MCS 0	High: CH11	2462

Note: According exploratory test, EUT will have maximum output power in those data rate, so those data rate were used for all test.

2.6 Test environment conditions

During the measurement the environmental conditions were within the listed ranges:

Temperature range:	21-25°C
Humidity range:	40-75%
Pressure range:	86-106kPa

2.7 Measurement uncertainty

Test Item	Uncertainty
Uncertainty for Conduction emission test	2.44dB
Uncertainty for Radiation Emission test (150KHz-30MHz)	3.21dB
Uncertainty for Radiation Emission test (30MHz-1GHz)	3.14 dB (Polarize: V)
	3.16 dB (Polarize: H)
Uncertainty for Radiation Emission test (1GHz to 25GHz)	2.08dB(Polarize: V)
	2.56dB (Polarize: H)
Uncertainty for radio frequency	1×10 ⁻⁹
Uncertainty for conducted RF Power	0.65dB

Note: This uncertainty represents an expanded uncertainty expressed at approximately the 95%

confidence level using a coverage factor of k=2.

3. 6dB Bandwidth and 99% Occupied Bandwidth

3.1 Test equipment

Item	Equipment	Manufacturer	Model No.	Serial No.	Cal.Due	Cal. Interval
1	EMI Test Receiver	R&S	ESCI	101307	2014/12/27	1Y

3.2 Block diagram of test setup

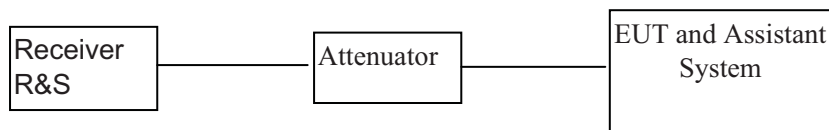

3.3 Limits

For direct sequence systems, the minimum 6dB bandwidth shall be at least 500 KHz

3.4 Test Procedure

- (1) Check the calibration of the measuring instrument using either an internal calibrator or a known signal from an external generator.
- (2) Position the EUT without connection to measurement instrument. Turn on the EUT and connect it to measurement instrument. Then set it to any one convenient frequency within its operating range. Set a reference level on the measuring instrument equal to the highest peak value.
- (3) Measure the frequency difference of two frequencies that were attenuated 6 dB from the reference level. Record the frequency difference as the emission bandwidth.
- (4) Repeat above procedures until all frequencies measured were complete.

3.5 Test Result

EUT Set Mode	CH or Frequency	6 dB bandwidth	99% dB bandwidth	Limt	Conclusion
		Result (MHz)	Result (MHz)	>500KHz	PASS

11b	CH1	10.3	15	>500KHz	PASS
	CH6	9.8	15	>500KHz	PASS
	CH11	10	15	>500KHz	PASS
11g	CH1	16.6	16.4	>500KHz	PASS
	CH6	16.6	16.5	>500KHz	PASS
	CH11	16.6	16.4	>500KHz	PASS
11n HT 20	CH1	16.6	16.5	>500KHz	PASS
	CH6	16.6	16.6	>500KHz	PASS
	CH11	16.7	16.5	>500KHz	PASS

3.6 Original test data

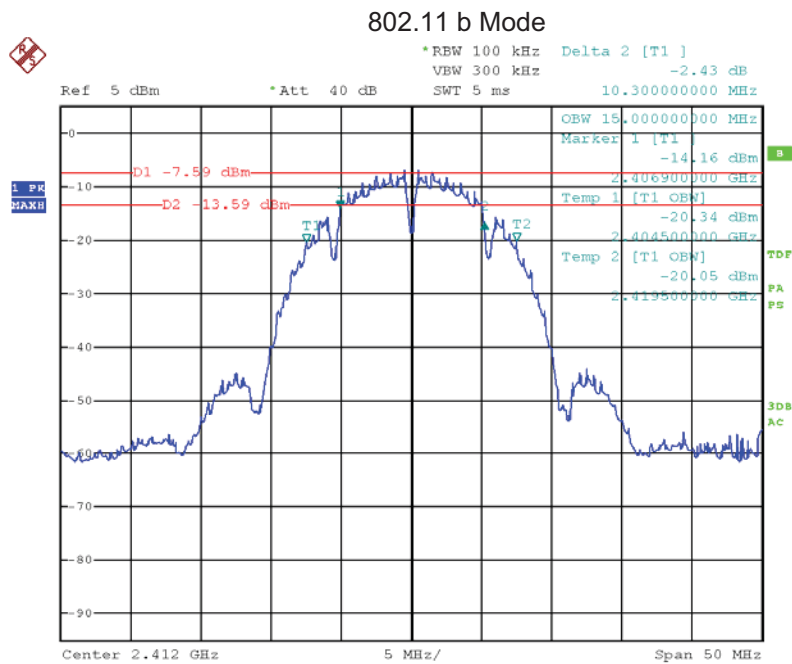

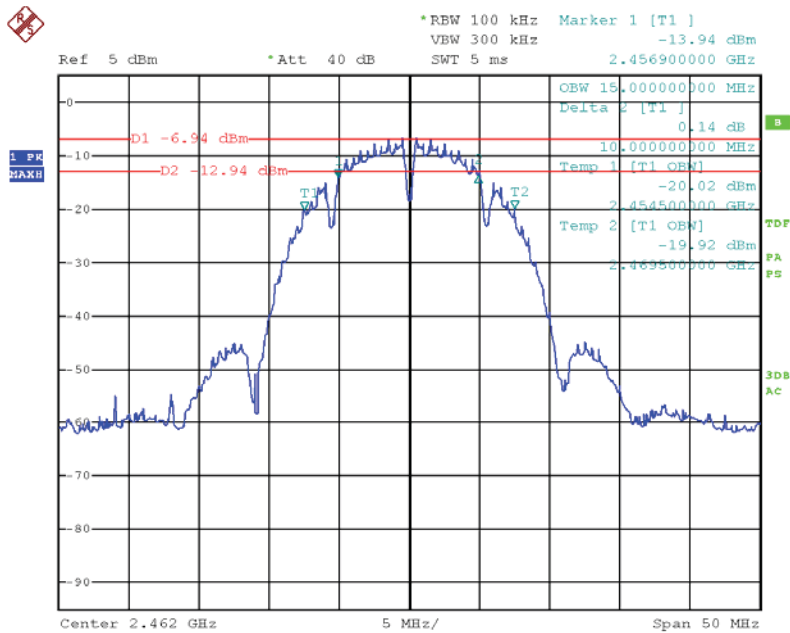
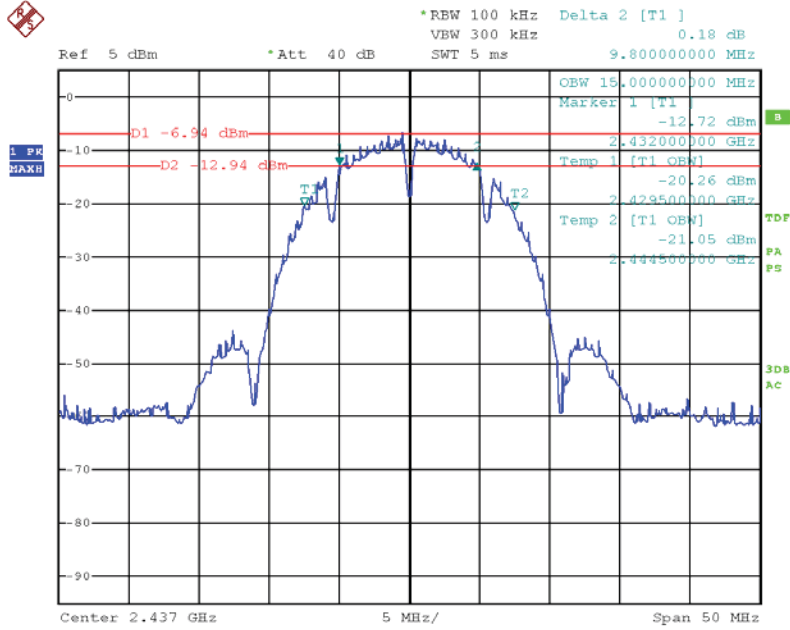

802.11 g Mode

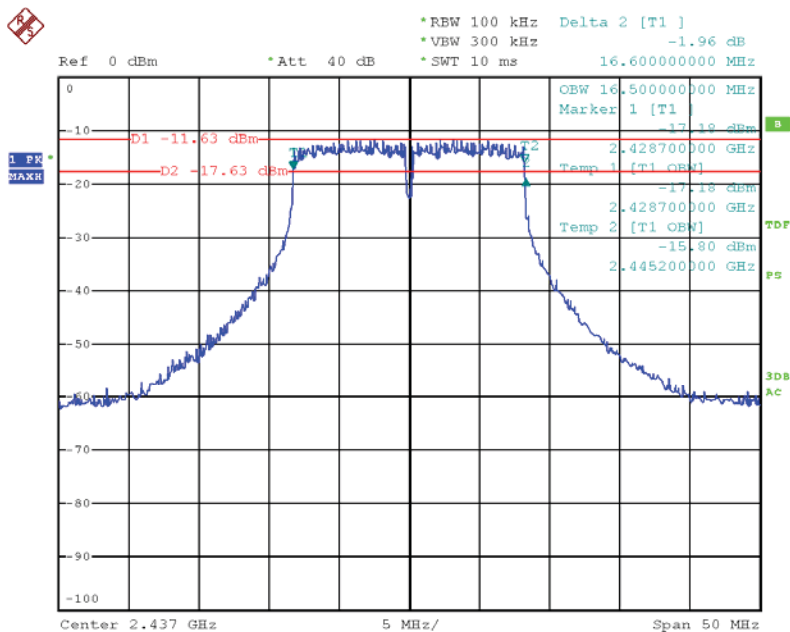
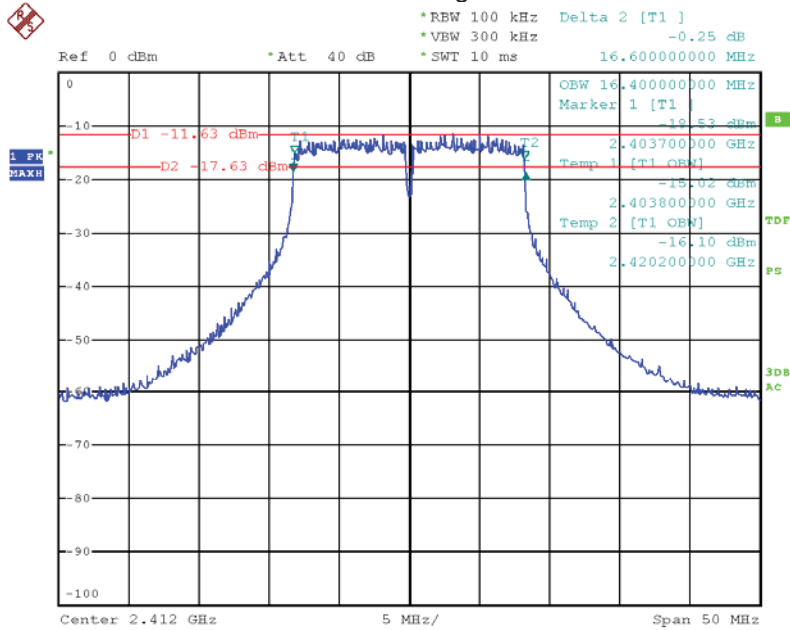

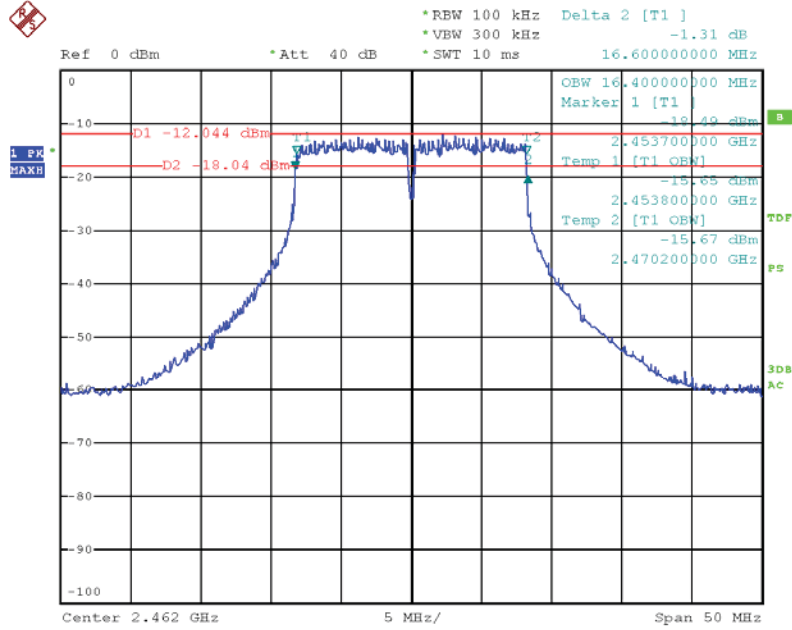

802.11 n20

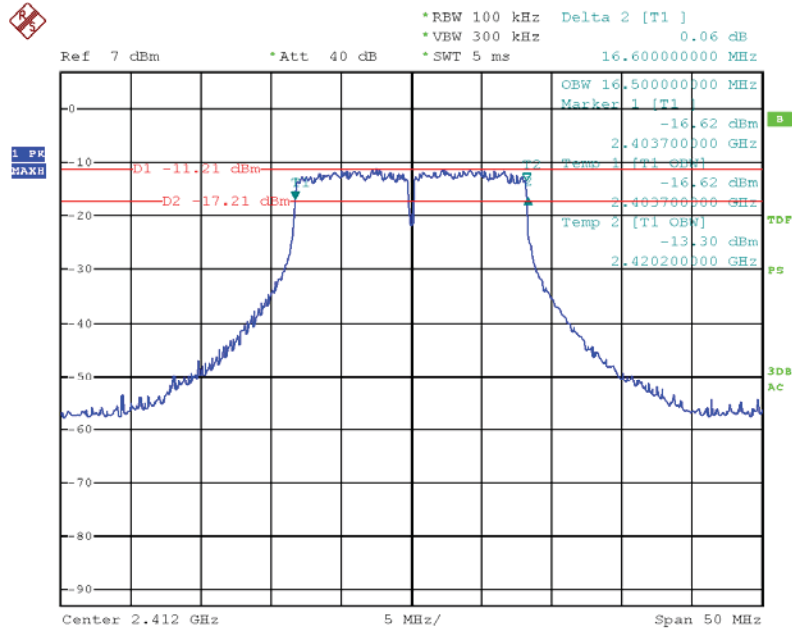

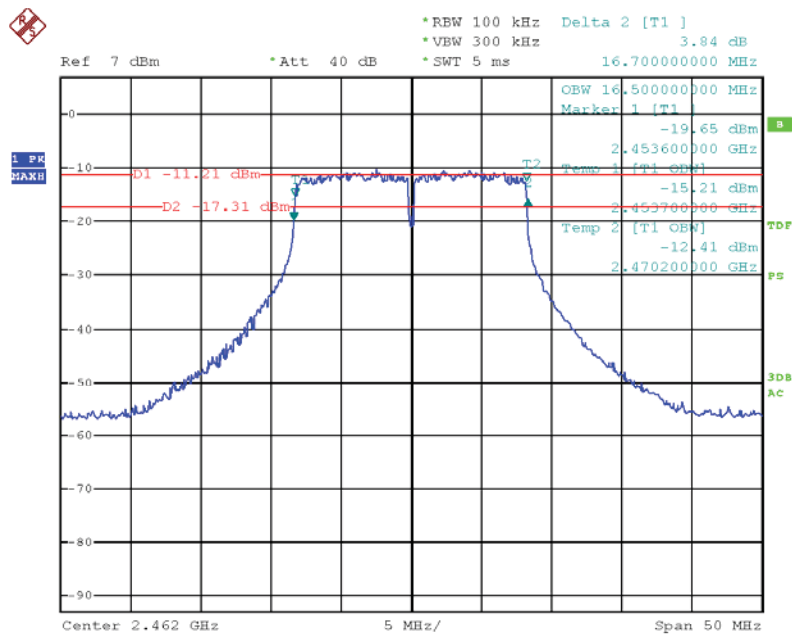
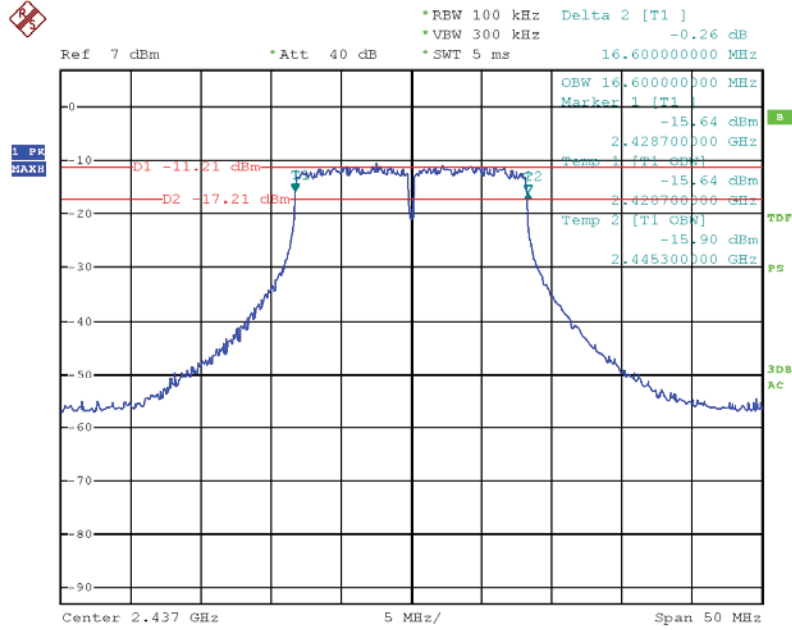

4. Maximum Peak Output Power

4.1 Test equipment

Item	Equipment	Manufacturer	Model No.	Serial No.	Cal.Due	Cal. Interval
1	Power meter	Agilent	E4417A	MY45100473	2014/12/27	1Y
2	Wireband Power sensor	Agilent	E4427A	MY5100041	2014/12/28	1Y

4.2 Block diagram of test setup

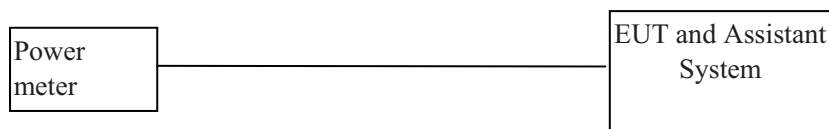

4.3 Limits

For systems using digital modulation in the 902-928 MHz, 2400-2483.5 MHz bands: 1 Watt. If transmitting antennas of directional gain greater than 6 dBi are used, the conducted output power from the intentional radiator shall be reduced below the stated values as appropriate, by the amount in dB that the directional gain of the antenna exceeds 6 dBi..

4.4 Test Procedure

1. Place the EUT on a bench and set it in transmitting mode. .
2. A wide band power meter with a matched thermocouple detector was used to directly measure the output power from the RF output port of the EUT in continuously transmitting mode.
3. The measurement shall be repeated at the lowest, the middle, and the highest channel of the stated frequency range.

4.5 Test Result

EUT Set Mode	Limit	Conclusion	CH	Result(dBm)
				Peak
11b	30dBm	PASS	CH1	7.53
			CH6	7.89
			CH11	7.99
11g	30dBm	PASS	CH1	8.81
			CH6	7.03
			CH11	7.24
11n HT20	30dBm	PASS	CH1	8.79
			CH6	9
			CH11	9.16

5. Power Spectral Density

5.1 Test equipment

Item	Equipment	Manufacturer	Model No.	Serial No.	Cal.Due	Cal. Interval
1	EMI Test Receiver	R&S	ESCI	101307	2014/12/27	1Y

5.2 Block diagram of test setup

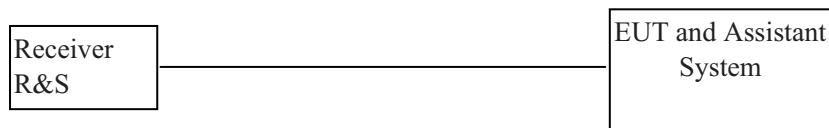

5.3 Limits

For digitally modulated systems, the power spectral density conducted from the intentional radiator to the antenna shall not be greater than 8dBm in any 3 kHz band during any time interval of continuous transmission.

5.4 Test Procedure

1. Check the calibration of the measuring instrument using either an internal calibrator or a known signal from an external generator.
2. Position the EUT was set without connection to measurement instrument. Turn on the EUT and connect its antenna terminal to measurement instrument via a low loss cable. Then set it to any one measured frequency within its operating range, and make sure the instrument is operated in its linear range
3. According to KDB 558074 D01 DTS Meas Guidance v03, set the RBW = 3 kHz, VBW = 30 kHz, Set the span to 1.5 times the DTS channel bandwidth.
4. Use the peak marker function to determine the maximum power level in any 3 kHz band segment within the fundamental EBW

5.5 Test Result

EUT Set Mode	CH or Frequency	Result	Limit: <dBm/3KHz	Conclusion
11b	CH1	-28.09	8	PASS
	CH6	-27.79	8	PASS
	CH11	-27.39	8	PASS
11g	CH1	-39.58	8	PASS
	CH6	-39.21	8	PASS
	CH11	-39.07	8	PASS
11n HT 20	CH1	-39.78	8	PASS
	CH6	-39.47	8	PASS
	CH11	-39.32	8	PASS

5.6 Original test data

802.11 b Mode

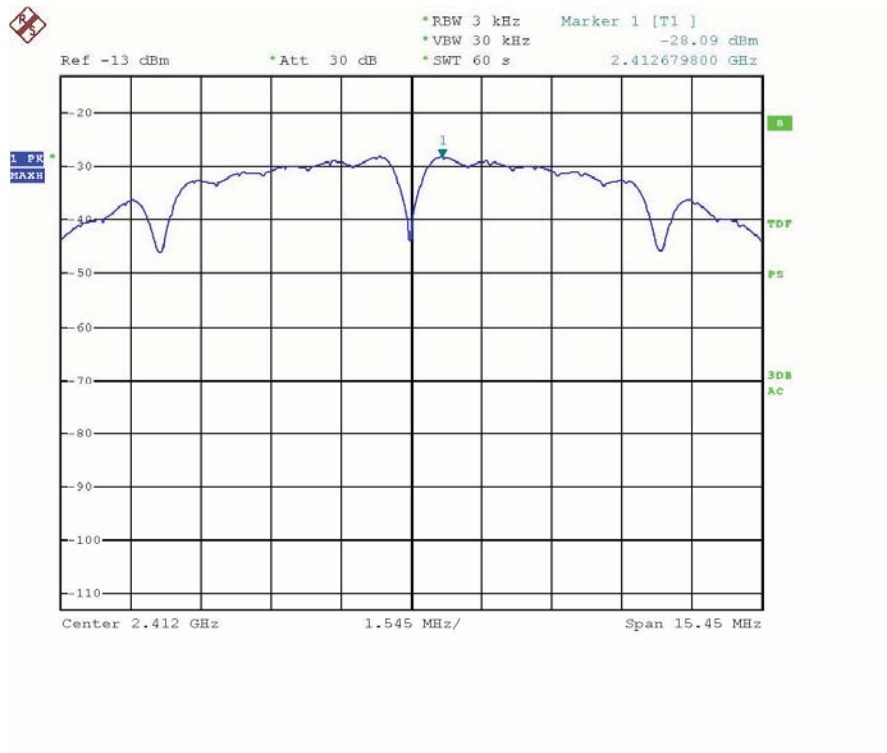

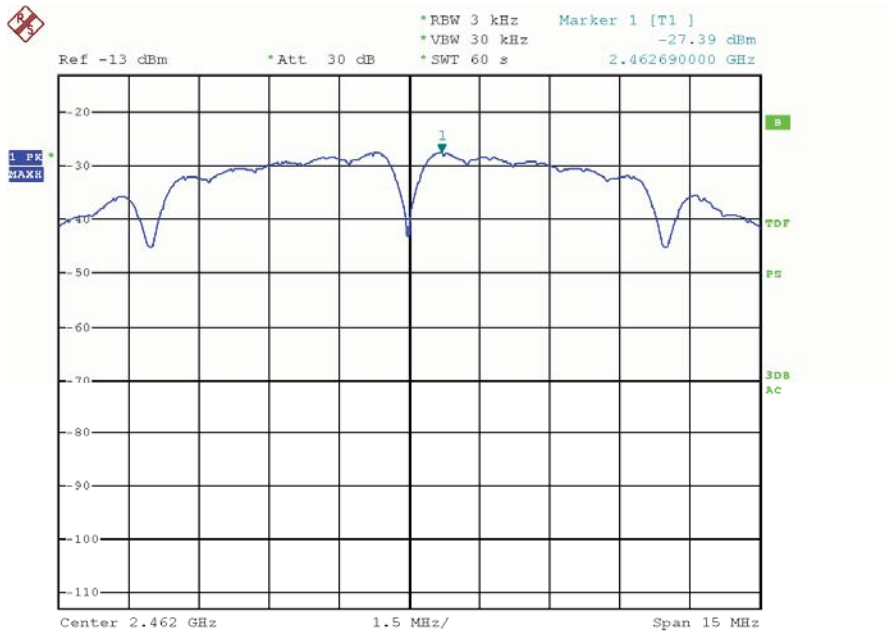
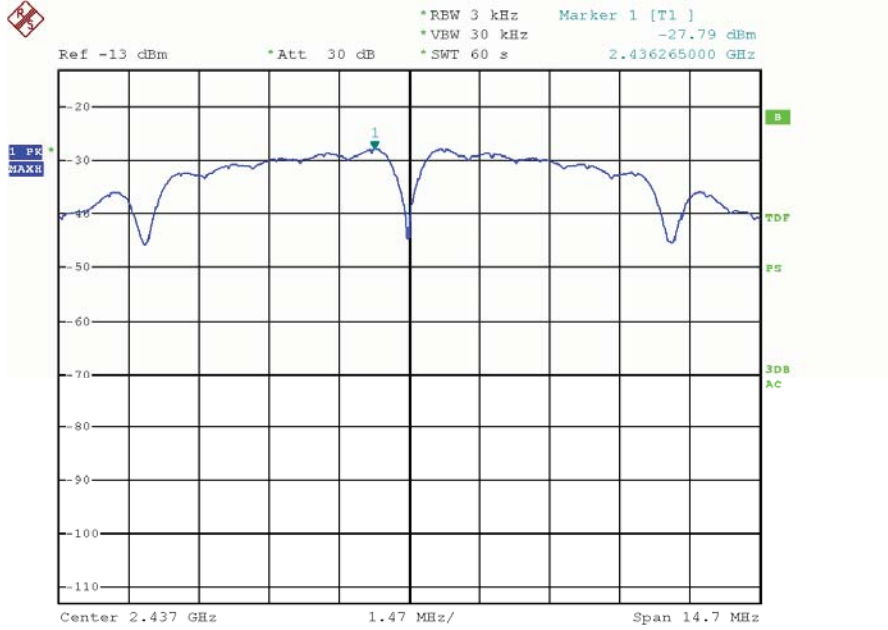

802.11 g Mode

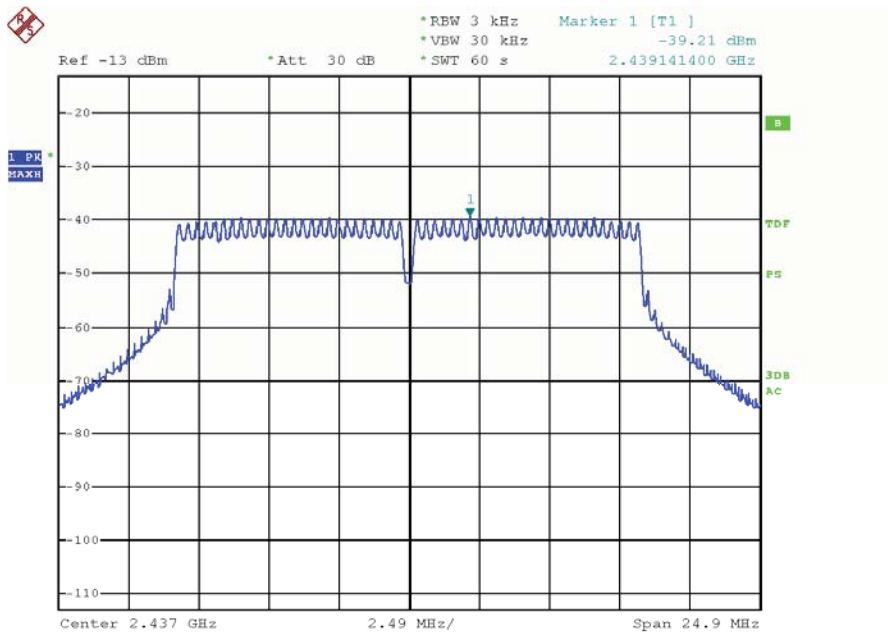
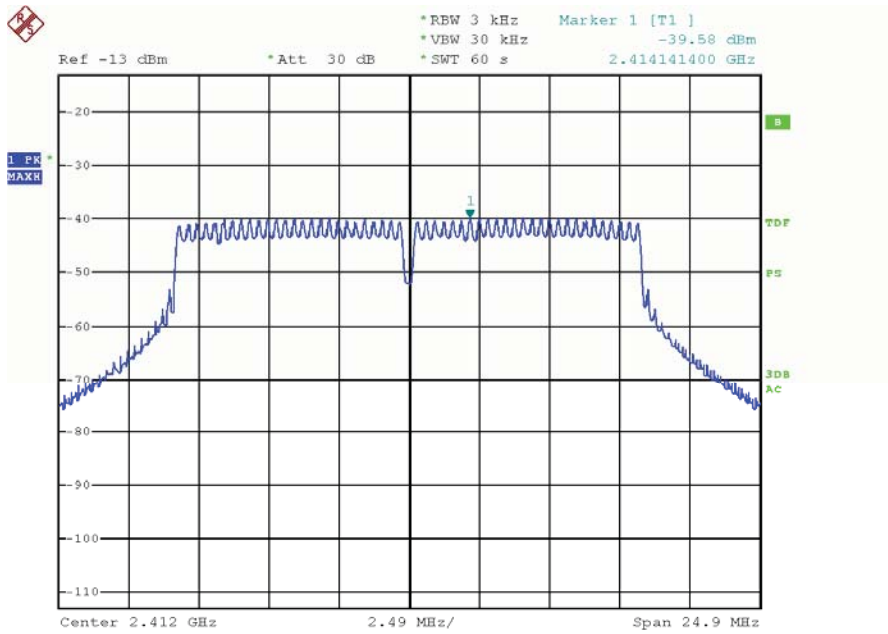

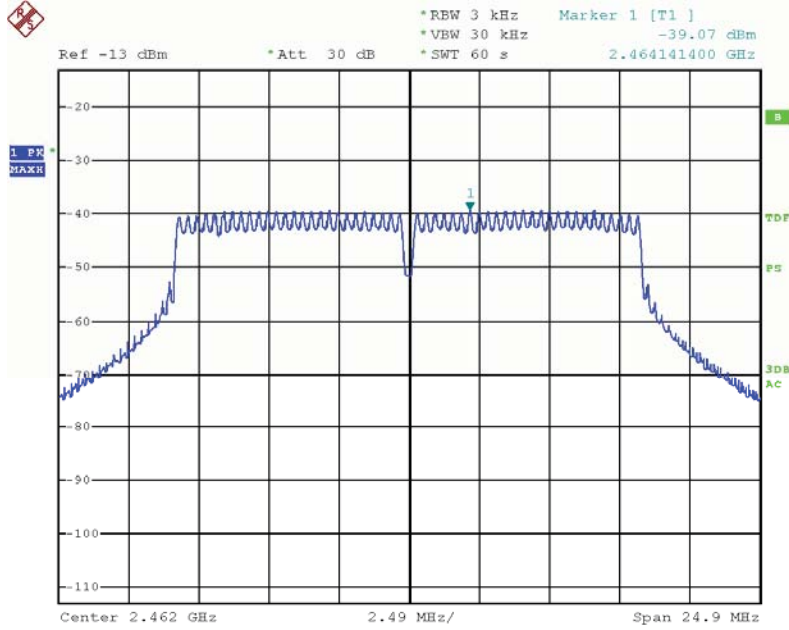

802.11 n20 Mode

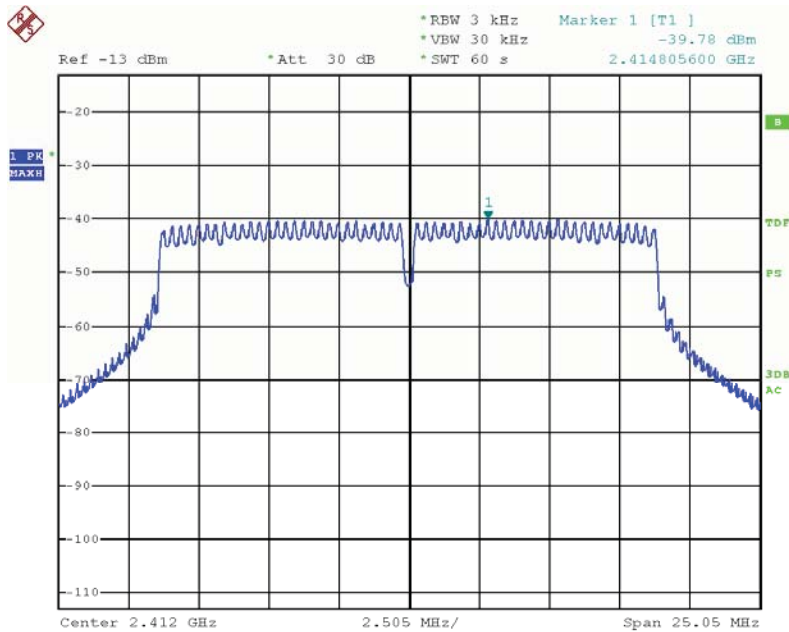

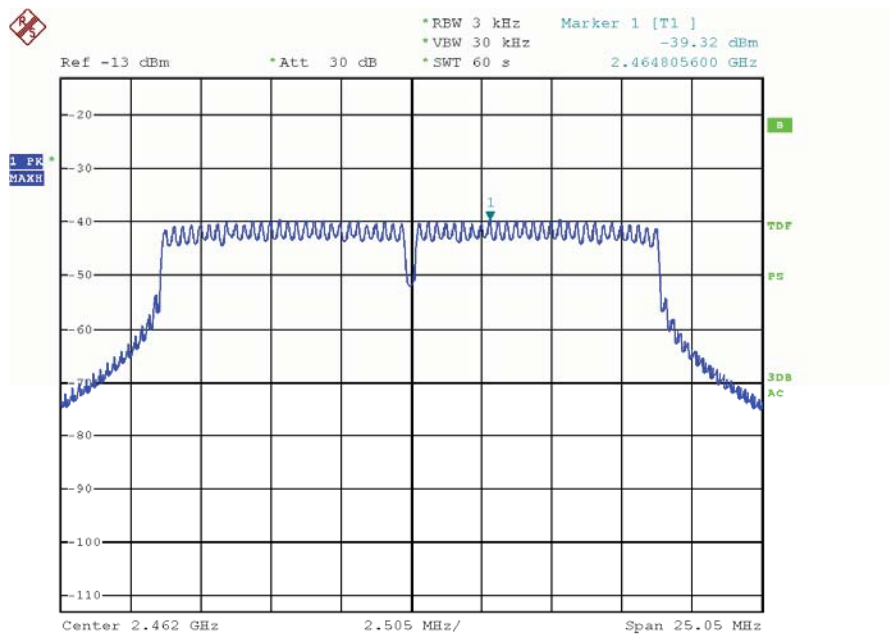
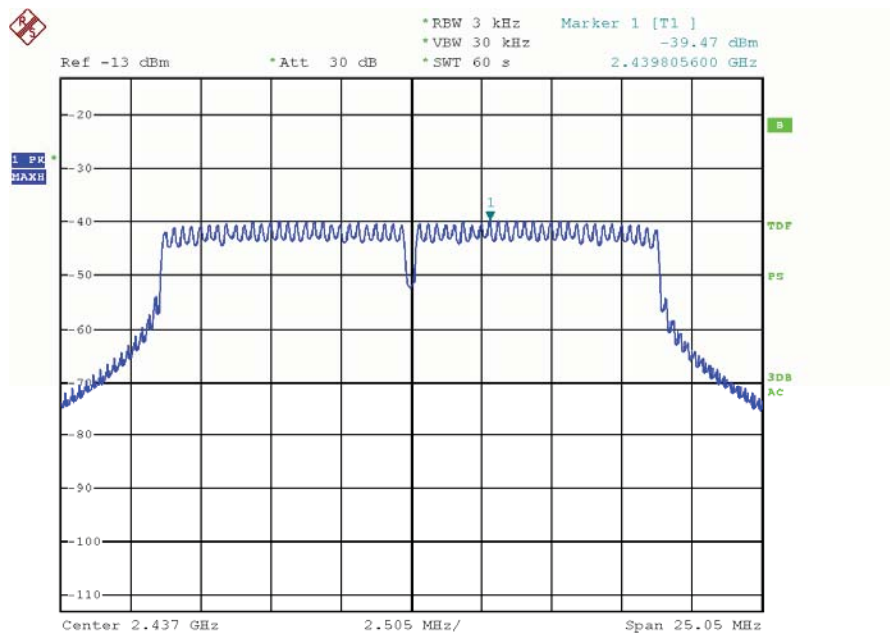

6. Spurious Emissions

6.1 Test equipment

Item	Equipment	Manufacturer	Model No.	Serial No.	Cal.Due	Cal. Interval
1	EMI Test Receiver	R&S	ESCI	101307	2014/12/27	1Y
2	Spectrum analyzer	Agilent	E4407B	US40240708	2014/12/28	1Y
3	Loop antenna	Chase	HLA6120	20129	2014/12/28	1Y
4	Trilog Broadband Antenna	Schwarzbeck	VULB9163	9163-462	2014/12/28	1Y
5	Double Ridged Horn Antenna	R&S	HF907	100276	2014/12/28	1Y
6	Pre-Amplifier	R&S	SCU-01	10049	2014/12/28	1Y
7	Pre-amplifier	A.H.	PAM0-0118	360	2014/12/28	1Y
8	RF Cable	R&S	R01	10403	2014/12/28	1Y
9	RF Cable	R&S	R02	10512	2014/12/28	1Y
10	Horn Antenna	EMCO	3116	9608-4877	2014/12/28	1Y

6.2 Block diagram of test setup

In 3m Anechoic Chamber Test Setup Diagram for below 1GHz

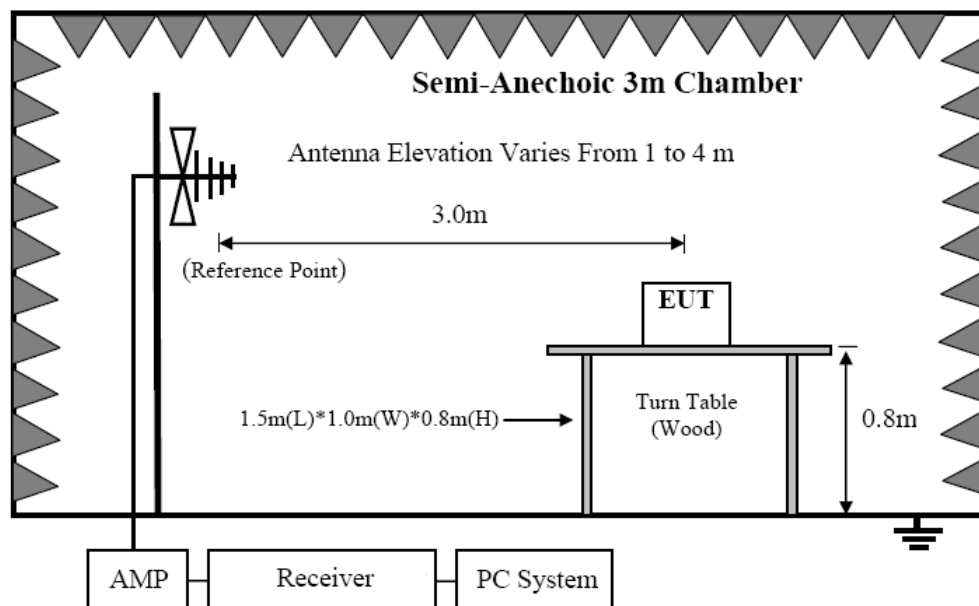

In 3m Anechoic Chamber Test Setup Diagram for frequency above 1GHz

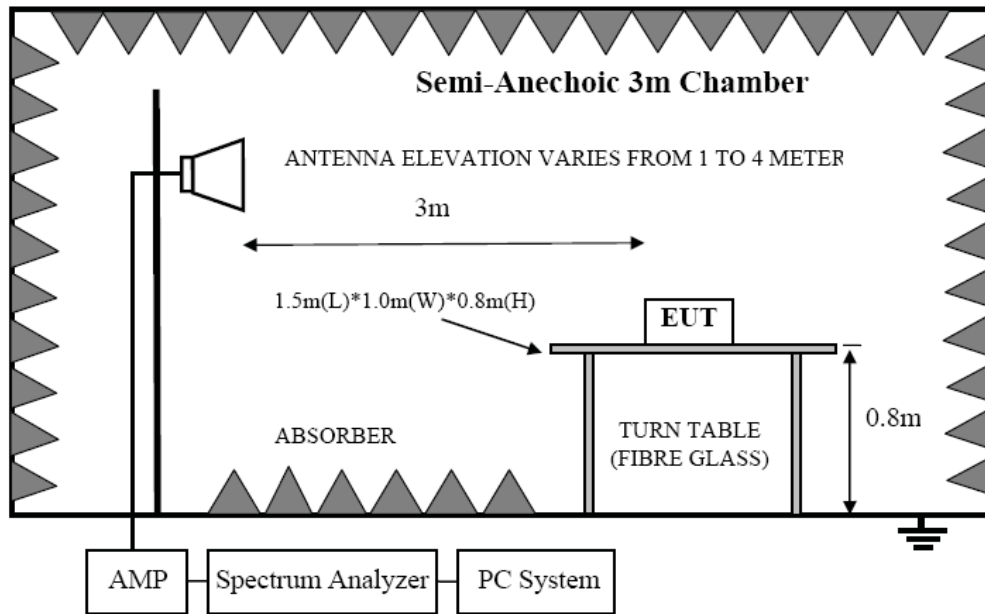

Note: For harmonic emissions test a appropriate high pass filter was inserted in the input port of AMP.

6.3 Limit

6.3.1 FCC 15.205 Restricted frequency band

MHz	MHz	MHz	GHz
0.090 - 0.110	16.42 - 16.423	399.9 - 410	4.5 - 5.15
¹ 0.495 - 0.505	16.69475 - 16.69525	608 - 614	5.35 - 5.46
2.1735 - 2.1905	16.80425 - 16.80475	960 - 1240	7.25 - 7.75
4.125 - 4.128	25.5 - 25.67	1300 - 1427	8.025 - 8.5
4.17725 - 4.17775	37.5 - 38.25	1435 - 1626.5	9.0 - 9.2
4.20725 - 4.20775	73 - 74.6	1645.5 - 1646.5	9.3 - 9.5
6.215 - 6.218	74.8 - 75.2	1660 - 1710	10.6 - 12.7
6.26775 - 6.26825	108 - 121.94	1718.8 - 1722.2	13.25 - 13.4
6.31175 - 6.31225	123 - 138	2200 - 2300	14.47 - 14.5
8.291 - 8.294	149.9 - 150.05	2310 - 2390	15.35 - 16.2
8.362 - 8.366	156.52475 - 156.52525	2483.5 - 2500	17.7 - 21.4
8.37625 - 8.38675	156.7 - 156.9	2690 - 2900	22.01 - 23.12
8.41425 - 8.41475	162.0125 - 167.17	3260 - 3267	23.6 - 24.0
12.29 - 12.293	167.72 - 173.2	3332 - 3339	31.2 - 31.8
12.51975 - 12.52025	240 - 285	3345.8 - 3358	36.43 - 36.5
12.57675 - 12.57725	322 - 335.4	3600 - 4400	(²)

6.3.2 FCC 15.209 Limit

FREQUENCY MHz	DISTANCE Meters	FIELD STRENGTHS LIMIT	
		μV/m	dB(μV)/m
30 ~ 88	3	100	40.0
88 ~ 216	3	150	43.5
216 ~ 960	3	200	46.0
960 ~ 1000	3	500	54.0
Above 1000	3	74.0 dB(μV)/m (Peak) 54.0 dB(μV)/m (Average)	

6.3.3 Limit for this EUT

The radiated emission tests were performed in the 3 meters test site, using the setup accordance with the ANSI C63.4-2009. The specification used was the FCC 15.209, and FCC 15.247 limits.

6.4 Test Procedure

- (1) EUT was placed on a non-metallic table, 80 cm above the ground plane inside a semi-anechoic chamber.
- (2) Setup EUT and assistant system according clause 2.4 and 8.2
- (3) Test antenna was located 3m from the EUT on an adjustable mast. Below pre-scan procedure was first performed in order to find prominent radiated emissions.
 - (a) Change work frequency or channel of device if practicable.
 - (b) Change modulation type of device if practicable.
 - (c) Change power supply range from 85% to 115% of the rated supply voltage
 - (d) Rotated EUT though three orthogonal axes to determine the attitude of EUT arrangement produces highest emissions
- (4) Spectrum frequency from 9MHz to 25GHz (tenth harmonic of fundamental frequency) was investigated, and no any obvious emission were detected from 9KHz to 30MHz and 18GHz to 25GHz, so below final test was performed with frequency range from 30MHz to 18GHz.
- (5) For final emissions measurements at each frequency of interest, the EUT were rotated and the antenna height was varied between 1m and 4m in order to maximize the emission. Measurements in both horizontal and vertical polarities were made and the data was recorded. In order to find the maximum emission, the relative positions of equipments and all of the interface cables were changed according to ANSI C63.10 2009 on Radiated Emission test.
- (6) For emissions from 30MHz to 1GHz, Quasi-Peak values were measured with EMI Receiver and the bandwidth of Receiver is 120 KHz.
- (7) For emissions above 1GHz, both Peak and Average level were measured with Spectrum Analyzer, and the RBW is set at 1MHz, VBW is set at 3MHz for Peak measure, Detector is at PK; RBW is set at 1MHz, VBW is set at 3MHz for Average measure, Detector is at RMS..

6.5 Test result

PASS. (See below detailed test result)

According to the recorded data in following table, the EUT complied with the FCC Title 47, Part 15, Subpart C, and section 15.205, 15.209 and 15.247, Vertical and Horizontal mode all have been tested. Horizontal mode is the worse case. with the worst margin reading of: 6.02 dB at 2483.5 MHz in the Horizontal polarization.

Radiated Emission Test Result

Test Site	: 3m Chamber	Tested By	: Bin Jiang
Test Date	: 2014-8-6	Model Number	: RICOH WG-M1
EUT	: Digital Camera	Test Mode	: 802.11 b
Power Supply	: DC 3.6V	Antenna/Distance	: 3m
Condition	: Temp:24.5°C,Humi:55%		

Frequency (MHz)	Receiver		Rx Antenna		Cable loss (dB)	Amplifier Gain (dB)	Corrected Amplitude (dBμV/m)	FCC 15.247	
	Reading (dBμV)	Detector (PK/QP/AV)	Polar (H/V)	Factor (dB)				Limit (dBμV/m)	Margin (dB)
Low Channel (2412)									
2412	62.35	PK	H	28	3.65	0	94	N/A	N/A
2412	55.83	AV	H	28	3.65	0	87.48	N/A	N/A
2412	72.32	PK	V	28	3.65	0	103.97	N/A	N/A
2412	66.36	AV	V	28	3.65	0	98.01	N/A	N/A
2390	28.63	PK	H	28.4	3.57	0	60.6	74	13.4
2390	15.47	AV	H	28.4	3.57	0	47.44	54	6.56
2390	27.58	PK	V	28.4	3.57	0	59.55	74	14.45
2390	14.57	AV	V	28.4	3.57	0	46.54	54	7.46
4824	44.32	PK	H	32.3	5.91	31.78	50.75	74	23.25
4824	28.96	AV	H	32.3	5.91	31.78	35.39	54	18.61
4824	42.84	PK	V	32.3	5.91	31.78	49.27	74	24.73
4824	26.48	AV	V	32.3	5.91	31.78	32.91	54	21.09
7236	43.51	PK	H	36.3	6.34	30.97	55.18	74	18.82
7236	27.66	AV	H	36.3	6.34	30.97	39.33	54	14.67
7236	4.67	PK	V	36.3	6.34	30.97	56.34	74	17.66
7236	25.87	AV	V	36.3	6.34	30.97	37.54	54	16.46
9648	44.11	PK	H	37.9	8.01	30.86	59.16	74	14.84
9648	27.08	AV	H	37.9	8.01	30.86	42.13	54	11.87
9648	39.91	PK	V	37.9	8.01	30.86	54.96	74	19.04
9648	24.86	AV	V	37.9	8.01	30.86	39.91	54	14.09
457.32	38.64	QP	H	12.8	2.63	27.2	26.87	46	19.13
457.25	36.87	QP	V	12.8	2.63	27.2	25.1	46	20.9
Middle Channel (2437)									
2437	64.08	PK	H	28.7	3.74	0	95.73	N/A	N/A
2437	57.32	AV	H	28.7	3.74	0	88.97	N/A	N/A
2437	73.07	PK	V	28.7	3.74	0	104.72	N/A	N/A
2437	66.22	AV	V	28.7	3.74	0	97.87	N/A	N/A
4874	43.65	PK	H	32.6	6.15	31.78	50.62	74	23.38
4874	29.14	AV	H	32.6	6.15	31.78	36.11	54	17.89
4874	42.84	PK	V	32.6	6.15	31.78	49.81	74	24.19
4874	28.95	AV	V	32.6	6.15	31.78	35.92	54	18.08

7311	44.25	PK	H	36.7	6.22	30.97	56.2	74	17.8
7311	29.88	AV	H	36.7	6.22	30.97	41.83	54	12.17
7311	43.56	PK	V	36.7	6.22	30.97	55.51	74	18.49
7311	29.21	AV	V	36.7	6.22	30.97	41.16	54	12.84
9748	43.02	PK	H	38.2	8.11	30.86	58.47	74	15.53
9748	28.14	AV	H	38.2	8.11	30.86	43.59	54	10.41
9748	43.19	PK	V	38.2	8.11	30.86	58.64	74	15.36
9748	28.75	AV	V	38.2	8.11	30.86	44.2	54	9.8
455.83	38.96	QP	H	12.8	2.63	27.2	27.19	46	18.81
456.04	37.58	QP	V	12.8	2.63	27.2	25.81	46	20.19
High Channel (2462)									
2462	63.16	PK	H	29.1	3.81	0	94.81	N/A	N/A
2462	56.87	AV	H	29.1	3.81	0	88.52	N/A	N/A
2462	72.89	PK	V	29.1	3.81	0	104.54	N/A	N/A
2462	65.68	AV	V	29.1	3.81	0	97.33	N/A	N/A
2483.5	30.63	PK	H	28.7	3.62	0	62.95	74	11.05
2483.5	17.04	AV	H	28.7	3.62	0	49.36	54	4.64
2483.5	28.54	PK	V	28.7	3.62	0	60.86	74	13.14
2483.5	16.87	AV	V	28.7	3.62	0	49.19	54	4.81
4924	43.52	PK	H	32.8	6.17	31.78	50.71	74	23.29
4924	30.12	AV	H	32.8	6.17	31.78	37.31	54	16.69
4924	41.67	PK	V	32.8	6.17	31.78	48.86	74	25.14
4924	30.24	AV	V	32.8	6.17	31.78	37.43	54	16.57
7386	42.35	PK	H	36.8	6.26	30.97	54.44	74	19.56
7386	29.61	AV	H	36.8	6.26	30.97	41.7	54	12.3
7386	41.89	PK	V	36.8	6.26	30.97	53.98	74	20.02
7386	29.34	AV	V	36.8	6.26	30.97	41.43	54	12.57
9848	40.15	PK	H	38.4	8.17	30.86	55.86	74	18.14
9848	28.33	AV	H	38.4	8.17	30.86	44.04	54	9.96
9848	39.86	PK	V	38.4	8.17	30.86	55.57	74	18.43
9848	28.67	AV	V	38.4	8.17	30.86	44.38	54	9.62
456.58	37.54	QP	H	12.8	2.63	27.2	25.77	46	20.03
456.43	38.47	QP	V	12.8	2.63	27.2	26.7	46	19.3

Test Site : 3m Chamber

Test Date : 2014-8-6

EUT : Digital Camera

Power Supply : DC 3.6V

Condition : Temp:24.5°C,Humi:55%

Tested By : Bin Jiang

Model Number : RICOH WG-M1

Test Mode : 802.11 g

Antenna/Distance : 3m

Frequency (MHz)	Receiver		Rx Antenna		Cable loss (dB)	Amplifier Gain (dB)	Corrected Amplitude (dB μ V/m)	FCC 15.247	
	Reading (dB μ V)	Detector (PK/QP/AV)	Polar (H/V)	Factor (dB)				Limit (dB μ V/m)	Margin (dB)
Low Channel (2412)									
2412	63.87	PK	H	28	3.65	0	95.52	N/A	N/A
2412	56.42	AV	H	28	3.65	0	88.07	N/A	N/A
2412	73.16	PK	V	28	3.65	0	104.81	N/A	N/A
2412	66.21	AV	V	28	3.65	0	97.86	N/A	N/A
2390	29.1	PK	H	28.4	3.57	0	61.07	74	12.93
2390	15.92	AV	H	28.4	3.57	0	47.89	54	6.11
2390	27.91	PK	V	28.4	3.57	0	59.55	74	14.45
2390	15.02	AV	V	28.4	3.57	0	46.54	54	7.46
4824	44.85	PK	H	32.3	5.91	31.78	51.28	74	22.72
4824	28.74	AV	H	32.3	5.91	31.78	35.17	54	18.83
4824	43.25	PK	V	32.3	5.91	31.78	49.27	74	24.73
4824	26.97	AV	V	32.3	5.91	31.78	32.91	54	21.09
7236	43.84	PK	H	36.3	6.34	30.97	55.51	74	18.49
7236	28.14	AV	H	36.3	6.34	30.97	39.81	54	14.19
7236	44.53	PK	V	36.3	6.34	30.97	56.2	74	17.8
7236	26.37	AV	V	36.3	6.34	30.97	38.04	54	15.96
9648	44.65	PK	H	37.9	8.01	30.86	59.7	74	14.3
9648	27.54	AV	H	37.9	8.01	30.86	42.59	54	11.41
9648	39.15	PK	V	37.9	8.01	30.86	54.2	74	19.8
9648	25.34	AV	V	37.9	8.01	30.86	40.39	54	13.61
457.18	38.21	QP	H	12.8	2.63	27.2	26.44	46	19.56
457.33	37.23	QP	V	12.8	2.63	27.2	25.46	46	20.54
Middle Channel (2437)									
2437	63.17	PK	H	28.7	3.74	0	94.82	N/A	N/A
2437	56.34	AV	H	28.7	3.74	0	87.99	N/A	N/A
2437	72.58	PK	V	28.7	3.74	0	104.23	N/A	N/A
2437	65.39	AV	V	28.7	3.74	0	97.04	N/A	N/A
4874	43.87	PK	H	32.6	6.15	31.78	50.84	74	23.16
4874	29.75	AV	H	32.6	6.15	31.78	36.72	54	17.28
4874	42.35	PK	V	32.6	6.15	31.78	49.32	74	24.68
4874	29.42	AV	V	32.6	6.15	31.78	36.39	54	17.61
7311	44.37	PK	H	36.7	6.22	30.97	56.32	74	17.68
7311	30.35	AV	H	36.7	6.22	30.97	42.3	54	11.7

7311	44.35	PK	V	36.7	6.22	30.97	56.3	74	17.7
7311	29.69	AV	V	36.7	6.22	30.97	41.64	54	12.36
9748	43.87	PK	H	38.2	8.11	30.86	59.32	74	14.68
9748	28.67	AV	H	38.2	8.11	30.86	44.12	54	9.88
9748	43.87	PK	V	38.2	8.11	30.86	59.32	74	14.68
9748	28.81	AV	V	38.2	8.11	30.86	44.26	54	9.74
458.31	39.51	QP	H	12.8	2.63	27.2	27.74	46	18.26
455.26	38.47	QP	V	12.8	2.63	27.2	26.7	46	19.3
High Channel (2462)									
2462	64.68	PK	H	29.1	3.81	0	96.33	N/A	N/A
2462	57.58	AV	H	29.1	3.81	0	89.23	N/A	N/A
2462	73.55	PK	V	29.1	3.81	0	105.2	N/A	N/A
2462	66.38	AV	V	29.1	3.81	0	98.03	N/A	N/A
2483.5	30.57	PK	H	28.7	3.62	0	62.89	74	11.11
2483.5	17.58	AV	H	28.7	3.62	0	49.9	54	4.1
2483.5	28.64	PK	V	28.7	3.62	0	60.96	74	13.04
2483.5	17.24	AV	V	28.7	3.62	0	49.56	54	4.44
4924	45.14	PK	H	32.8	6.17	31.78	52.33	74	21.67
4924	31.24	AV	H	32.8	6.17	31.78	38.43	54	15.57
4924	41.57	PK	V	32.8	6.17	31.78	48.76	74	25.24
4924	30.86	AV	V	32.8	6.17	31.78	38.05	54	15.95
7386	42.78	PK	H	36.8	6.26	30.97	54.87	74	19.13
7386	30.24	AV	H	36.8	6.26	30.97	42.33	54	11.67
7386	42.54	PK	V	36.8	6.26	30.97	54.63	74	19.37
7386	29.82	AV	V	36.8	6.26	30.97	41.91	54	12.09
9848	40.72	PK	H	38.4	8.17	30.86	56.43	74	17.57
9848	29.34	AV	H	38.4	8.17	30.86	45.05	54	8.95
9848	39.75	PK	V	38.4	8.17	30.86	55.46	74	18.54
9848	28.16	AV	V	38.4	8.17	30.86	43.87	54	10.13
456.88	37.18	QP	H	12.8	2.63	27.2	25.41	46	20.59
456.65	39.26	QP	V	12.8	2.63	27.2	27.49	46	18.51

Test Site : 3m Chamber

Test Date : 2014-8-6

EUT : Digital Camera

Power Supply : DC 3.6V

Condition : Temp:24.5°C,Humi:55%

Tested By : Bin Jiang

Model Number : RICOH WG-M1

Test Mode : 802.11 n20

Antenna/Distance : 3m

Frequency (MHz)	Receiver		Rx Antenna		Cable loss (dB)	Amplifier Gain (dB)	Corrected Amplitude (dB μ V/m)	FCC 15.247	
	Reading (dB μ V)	Detector (PK/QP/AV)	Polar (H/V)	Factor (dB)				Limit (dB μ V/m)	Margin (dB)
Low Channel (2402)									
2412	65.36	PK	H	28	3.65	0	97.01	N/A	N/A
2412	58.83	AV	H	28	3.65	0	90.48	N/A	N/A
2412	74.32	PK	V	28	3.65	0	105.97	N/A	N/A
2412	69.36	AV	V	28	3.65	0	101.01	N/A	N/A
2390	30.42	PK	H	28.4	3.57	0	62.39	74	11.61
2390	16.38	AV	H	28.4	3.57	0	48.35	54	5.65
2390	28.34	PK	V	28.4	3.57	0	59.55	74	14.45
2390	15.84	AV	V	28.4	3.57	0	46.54	54	7.46
4824	45.27	PK	H	32.3	5.91	31.78	51.7	74	22.3
4824	28.35	AV	H	32.3	5.91	31.78	34.78	54	19.22
4824	43.67	PK	V	32.3	5.91	31.78	49.27	74	24.73
4824	26.51	AV	V	32.3	5.91	31.78	32.91	54	21.09
7236	.25	PK	H	36.3	6.34	30.97	54.92	74	19.08
7236	28.99	AV	H	36.3	6.34	30.97	40.66	54	13.34
7236	43.12	PK	V	36.3	6.34	30.97	54.79	74	19.21
7236	26.37	AV	V	36.3	6.34	30.97	38.04	54	15.96
9648	44.57	PK	H	37.9	8.01	30.86	59.62	74	14.38
9648	27.31	AV	H	37.9	8.01	30.86	42.36	54	11.64
9648	39.5	PK	V	37.9	8.01	30.86	54.55	74	19.45
9648	25.81	AV	V	37.9	8.01	30.86	40.86	54	13.14
458.43	38.6	QP	H	12.8	2.63	27.2	26.83	46	19.17
458.25	37.84	QP	V	12.8	2.63	27.2	26.07	46	19.93
Middle Channel (2437)									
2437	64.88	PK	H	28.7	3.74	0	96.53	N/A	N/A
2437	59.62	AV	H	28.7	3.74	0	91.27	N/A	N/A
2437	75.13	PK	V	28.7	3.74	0	106.78	N/A	N/A
2437	68.24	AV	V	28.7	3.74	0	99.89	N/A	N/A
4874	43.19	PK	H	32.6	6.15	31.78	50.16	74	23.84
4874	29.57	AV	H	32.6	6.15	31.78	36.54	54	17.46
4874	42.96	PK	V	32.6	6.15	31.78	49.93	74	24.07
4874	30.01	AV	V	32.6	6.15	31.78	36.98	54	17.02
7311	44.84	PK	H	36.7	6.22	30.97	56.79	74	17.21
7311	30.84	AV	H	36.7	6.22	30.97	42.79	54	11.21

7311	44.76	PK	V	36.7	6.22	30.97	56.71	74	17.29
7311	30.21	AV	V	36.7	6.22	30.97	42.16	54	11.84
9748	44.15	PK	H	38.2	8.11	30.86	59.6	74	14.4
9748	29.16	AV	H	38.2	8.11	30.86	44.61	54	9.39
9748	44.02	PK	V	38.2	8.11	30.86	59.47	74	14.53
9748	28.36	AV	V	38.2	8.11	30.86	43.81	54	10.19
456.38	39.87	QP	H	12.8	2.63	27.2	28.1	46	17.9
455.62	38.76	QP	V	12.8	2.63	27.2	26.99	46	19.01
High Channel (2462)									
2462	65.04	PK	H	29.1	3.81	0	96.69	N/A	N/A
2462	58.69	AV	H	29.1	3.81	0	90.34	N/A	N/A
2462	74.81	PK	V	29.1	3.81	0	106.46	N/A	N/A
2462	67.03	AV	V	29.1	3.81	0	98.68	N/A	N/A
2483.5	30.87	PK	H	28.7	3.62	0	63.19	74	10.81
2483.5	17.43	AV	H	28.7	3.62	0	49.75	54	4.25
2483.5	28.41	PK	V	28.7	3.62	0	60.73	74	13.27
2483.5	17.88	AV	V	28.7	3.62	0	50.2	54	3.8
4924	44.67	PK	H	32.8	6.17	31.78	51.86	74	22.14
4924	31.57	AV	H	32.8	6.17	31.78	38.76	54	15.24
4924	43.98	PK	V	32.8	6.17	31.78	51.17	74	22.83
4924	31.27	AV	V	32.8	6.17	31.78	38.46	54	15.54
7386	42.33	PK	H	36.8	6.26	30.97	54.42	74	19.58
7386	30.63	AV	H	36.8	6.26	30.97	42.72	54	11.28
7386	42.66	PK	V	36.8	6.26	30.97	54.75	74	19.25
7386	30.17	AV	V	36.8	6.26	30.97	42.26	54	11.74
9848	40.24	PK	H	38.4	8.17	30.86	55.95	74	18.05
9848	29.86	AV	H	38.4	8.17	30.86	45.57	54	8.43
9848	40.31	PK	V	38.4	8.17	30.86	56.02	74	17.98
9848	28.75	AV	V	38.4	8.17	30.86	44.46	54	9.54
456.76	37.85	QP	H	12.8	2.63	27.2	26.08	46	19.92
458.31	39.24	QP	V	12.8	2.63	27.2	27.47	46	18.53

Note: 1. Result Level = Read Level + Antenna Factor + Cable loss - PRM Factor
 2. If Peak Result comply with QP limit, QP Result is deemed to comply with QP limit

7. 100 kHz Bandwidth of Frequency Band Edge

7.1 Test equipment

Item	Equipment	Manufacturer	Model No.	Serial No.	Cal.Due	Cal. Interval
1	Spectrum analyzer	Agilent	E4407B	US40240708	2014/12/28	1Y
2	RF Cable	R&S	R02	10512	2014/12/28	1Y

7.2 Block diagram of test setup

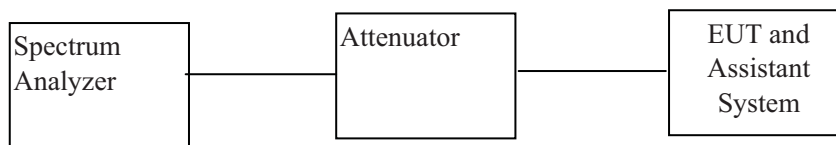

7.3 Limit

In any 100 kHz bandwidth outside the frequency band in which the spread spectrum or digitally modulated intentional radiator is operating, the radio frequency power that is produced by the intentional radiator shall be at least 20 dB below that in the 100 kHz bandwidth within the band that contains the highest level of the desired power, based on either an RF conducted or a radiated measurement, provided the transmitter demonstrates compliance with the peak conducted power limits. If the transmitter complies with the conducted power limits based on the use of RMS averaging over a time interval, as permitted under paragraph (b)(3) of this section, the attenuation required under this paragraph shall be 30 dB instead of 20 dB. Attenuation below the general limits specified in §15.209(a) is not required. In addition, radiated emissions which fall in the restricted bands, as defined in §15.205(a), must also comply with the radiated emission limits specified in §15.209(a) (see §15.205(c)).

7.4 Test Procedure

1. Check the calibration of the measuring instrument using either an internal calibrator or a known signal from an external generator.
2. Remove the antenna from the EUT and then connect to a low loss RF cable from the antenna port to a EMI test receiver, then turn on the EUT and make it operate in transmitting mode. Then set it to Low Channel and High Channel within its operating range, and make sure the instrument is operated in its linear range.
3. Set both RBW and VBW of spectrum analyzer to 100 kHz with a convenient frequency span including 100 kHz bandwidth from band edge.
4. Measure the highest amplitude appearing on spectral display and set it as a reference level. Plot the graph with marking the highest point and edge frequency.
5. Repeat above procedures until all measured frequencies were complete..

7.5 Test result

PASS. (hopping on and hopping off mode all have been tested , hopping off mode is the worse case ,See below detailed test result)

802.11 b Mode

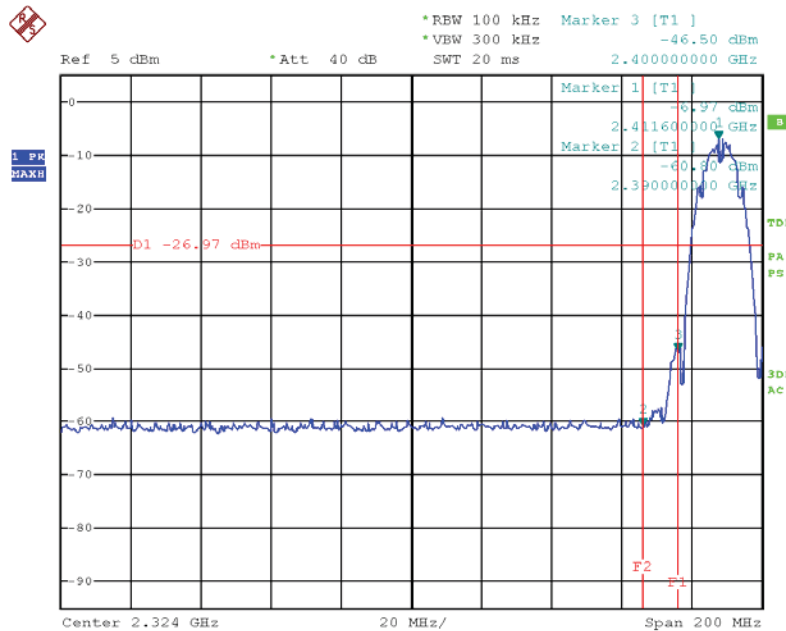

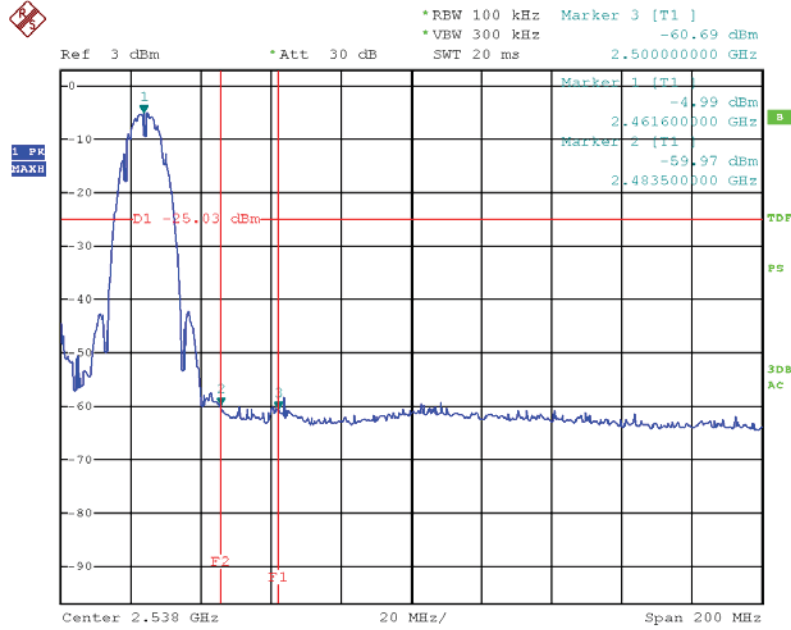

802.11 g Mode

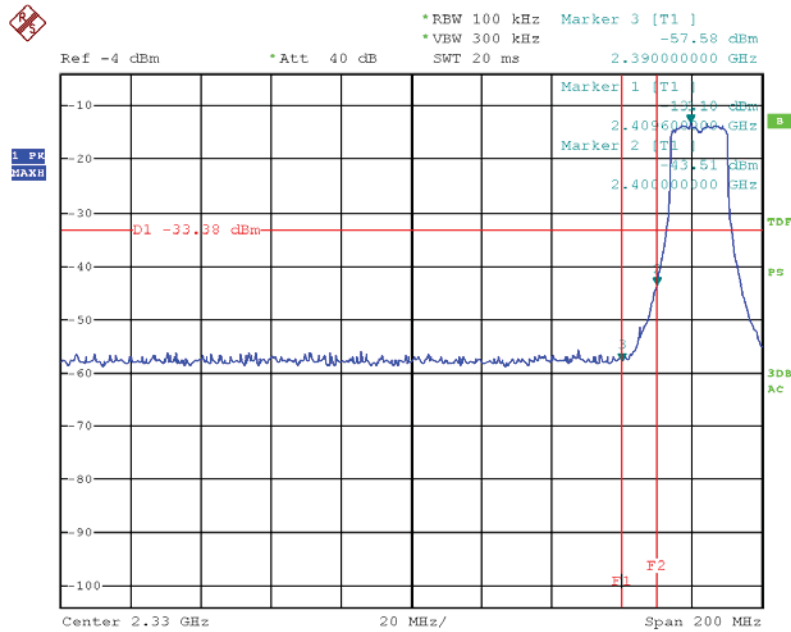

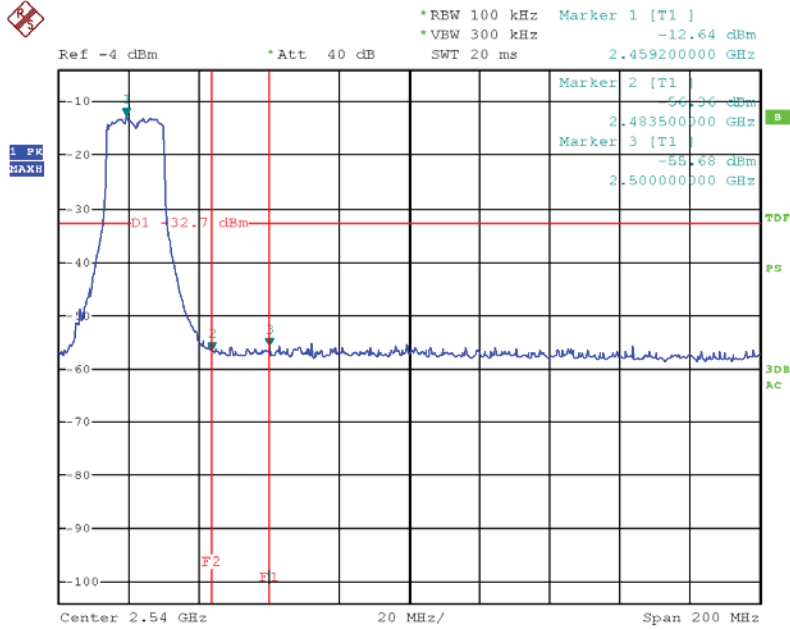

802.11 n20 Mode

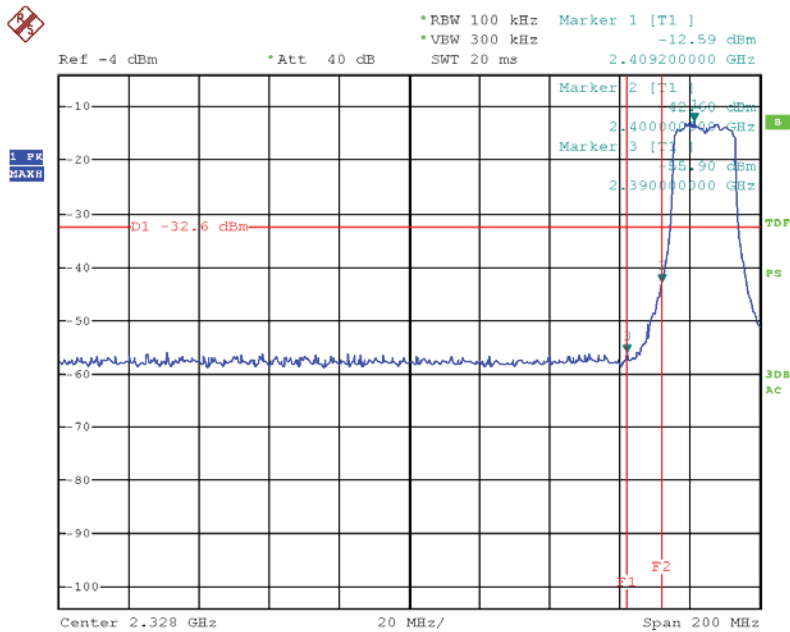

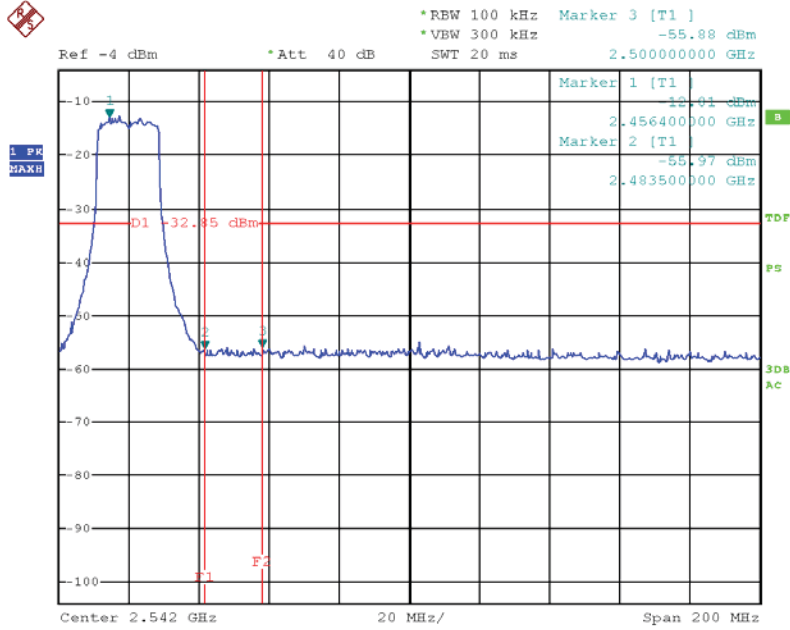

8. Power Line Conducted Emission

8.1 Test equipment

Item	Equipment	Manufacturer	Model No.	Serial No.	Cal.Due	Cal. Interval
1	Test Receiver	R&S	ESCI	101308	2014/12/27	1 Year
2	LISN 1	AFJ	LS16	16011103219	2014/12/28	1 Year
3	LISN 2	R&S	ESH2-Z5	100309	2014/12/28	1 Year
4	Pulse Limiter	MTS-systemtechnik	MTS-IMP-136	261115-010-0024	2014/12/28	1 Year

8.2 Block diagram of test setup

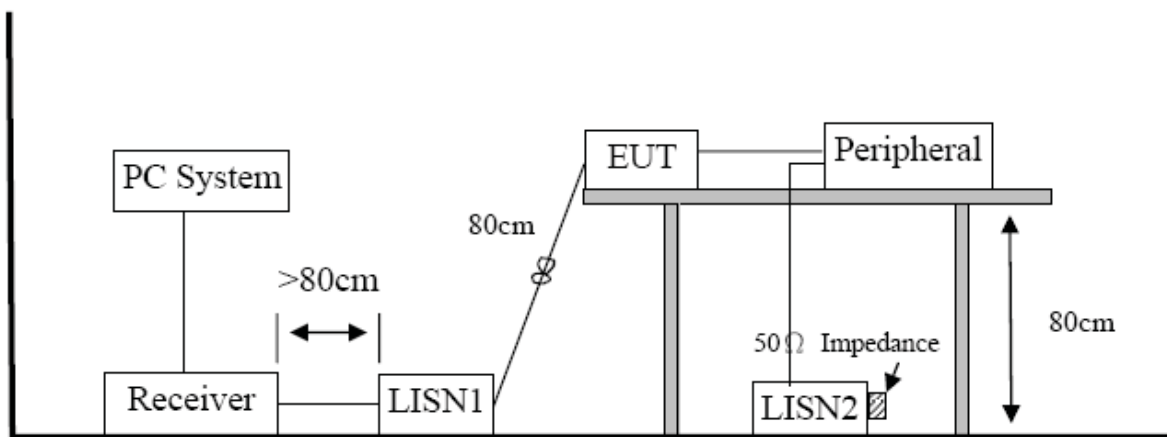

8.3 Power Line Conducted Emission Limits(Class B)

Frequency	Quasi-Peak Level dB(μV)	Average Level dB(μV)
150kHz ~ 500kHz	66 ~ 56*	56 ~ 46*
500kHz ~ 5MHz	56	46
5MHz ~ 30MHz	60	50

Note 1: * Decreasing linearly with logarithm of frequency.

Note 2: The lower limit shall apply at the transition frequencies.

8.4 Test Procedure

The EUT and Support equipment, if needed, were put placed on a non-metallic table, 80cm above the ground plane.

Configuration EUT to simulate typical usage as described in clause 2.4 and test equipment as described in clause 10.2 of this report.

All I/O cables were positioned to simulate typical actual usage as per ANSI C63.4.

All support equipment power received from a second LISN.

Emissions were measured on each current carrying line of the EUT using an EMI Test Receiver connected to the LISN powering the EUT.

The Receiver scanned from 150 kHz to 30MHz for emissions in each of the test modes.

During the above scans, the emissions were maximized by cable manipulation.

The test mode(s) described in clause 2.4 were scanned during the preliminary test.

After the preliminary scan, we found the test mode producing the highest emission level.

The EUT configuration and worse cable configuration of the above highest emission levels were recorded for reference of the final test.

EUT and support equipment were set up on the test bench as per the configuration with highest emission level in the preliminary test.

A scan was taken on both power lines, Neutral and Line, recording at least the six highest emissions.

Emission frequency and amplitude were recorded into a computer in which correction factors were used to calculate the emission level and compare reading to the applicable limit.

The test data of the worst-case condition(s) was recorded.

The bandwidth of test receiver is set at 9 KHz.

8.5 Test Result

pass. (See below detailed test result)

Note1: All emissions not reported below are too low against the prescribed limits.

Note2: "----" means average detection; "----" mans peak detection

EUT:	Digital Camera	Model No.:	RICOH WG-M1
Temperature:	24°C	Relative Humidity:	55%
Probe:	L1	Test Power:	AC 120V/60Hz
Standard:	FCC PART 15 class B_QP	Test Result:	Pass
Test Mode:	transmitting+charging	Test By:	Vito

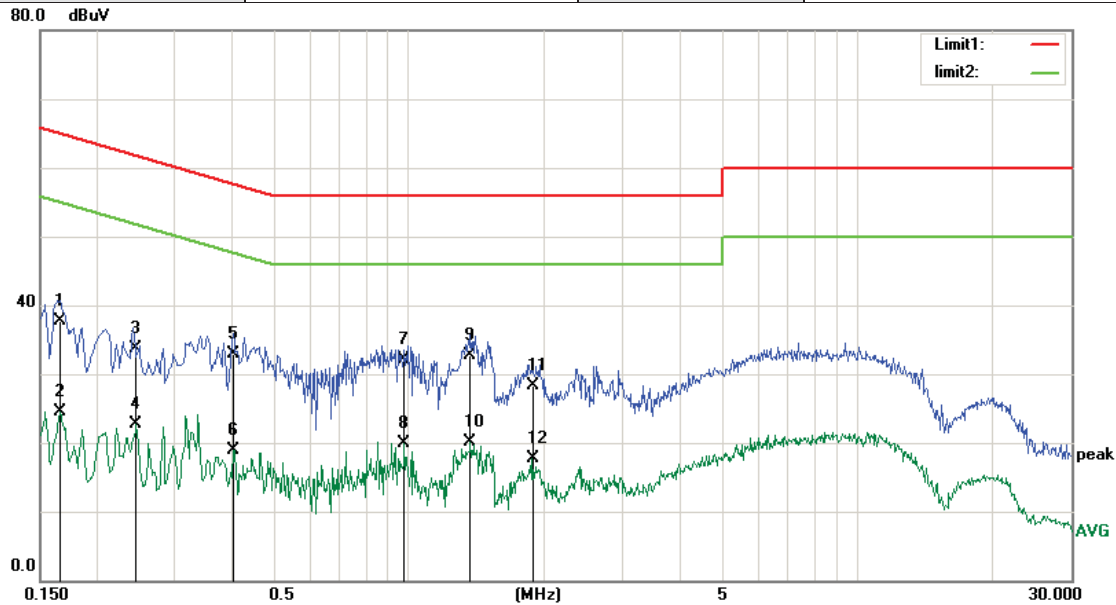

No.	Frequency (MHz)	Reading (dBuV)	Correct Factor(dB)	Result (dBuV)	Limit (dBuV)	Margin (dB)	Remark
1	0.1660	26.32	11.36	37.68	65.15	-27.47	QP
2	0.1660	13.19	11.36	24.55	55.15	-30.60	AVG
3	0.2459	22.97	10.81	33.78	61.89	-28.11	QP
4	0.2459	11.98	10.81	22.79	51.89	-29.10	AVG
5	0.4060	22.69	10.30	32.99	57.73	-24.74	QP
6	0.4060	8.63	10.30	18.93	47.73	-28.80	AVG
7	0.9778	21.91	10.10	32.01	56.00	-23.99	QP
8	0.9778	9.72	10.10	19.82	46.00	-26.18	AVG
9	1.3700	22.54	10.10	32.64	56.00	-23.36	QP
10	1.3700	10.01	10.10	20.11	46.00	-25.89	AVG
11	1.8817	18.27	10.11	28.38	56.00	-27.62	QP
12	1.8817	7.65	10.11	17.76	46.00	-28.24	AVG

EUT:	Digital Camera	Model No.:	RICOH WG-M1
------	----------------	------------	-------------

Temperature:	24°C	Relative Humidity:	55%
Probe:	N	Test Power:	AC 120V/60Hz
Standard:	FCC PART 15 class B_QP	Test Result:	Pass
Test Mode:	transmitting+charging	Test By:	Vito

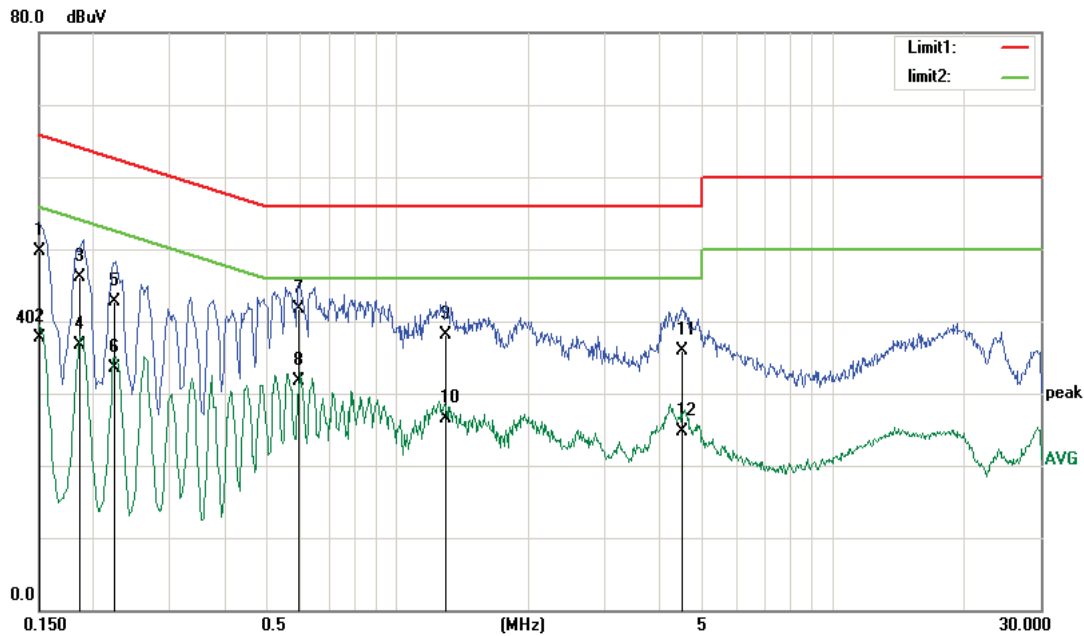

No.	Frequency (MHz)	Reading (dBuV)	Correct Factor(dB)	Result (dBuV)	Limit (dBuV)	Margin (dB)	Remark
1	0.1945	24.73	11.16	35.89	63.84	-27.95	QP
2	0.1945	10.13	11.16	21.29	53.84	-32.55	AVG
3	0.3738	22.00	10.34	32.34	58.41	-26.07	QP
4	0.3738	15.22	10.34	25.56	48.41	-22.85	AVG
5	0.6938	18.63	10.12	28.75	56.00	-27.25	QP
6	0.6938	5.14	10.12	15.26	46.00	-30.74	AVG
7	1.0980	18.84	10.10	28.94	56.00	-27.06	QP
8	1.0980	7.74	10.10	17.84	46.00	-28.16	AVG
9	2.2900	15.81	10.12	25.93	56.00	-30.07	QP
10	2.2900	6.72	10.12	16.84	46.00	-29.16	AVG
11	6.1139	20.11	10.11	30.22	60.00	-29.78	QP
12	6.1139	9.29	10.11	19.40	50.00	-30.60	AVG

9. Conducted Spurious Emissions

9.1. Test Equipment

Item	Equipment	Manufacturer	Model No.	Serial No.	Cal.Due	Cal. Interval
1	Spectrum analyzer	Agilent	E4407B	US40240708	2014/12/28	1Y
2	Attenuator	Mini-Circuits	BW-S10W2	101109	2014/12/28	1 Y
3	RF Cable	Micable	C10-01-01-1	100309	2014/12/28	1Y

9.2. Limit

In any 100kHz bandwidth outside the frequency bands in which the spread spectrum intentional radiator is operating, the radio frequency power that is produced by the intentional radiator shall be at least 20dB below that in the 100kHz bandwidth within the band that contains the highest level of the desired power.

9.3. Test Procedure

The transmitter output was connected to a spectrum analyzer, The resolution bandwidth is set to 100 kHz, The video bandwidth is set to 300 kHz and measure all the emissions detected.

9.4. Test result

PASS (See below detailed test result.)

802.11 b Mode

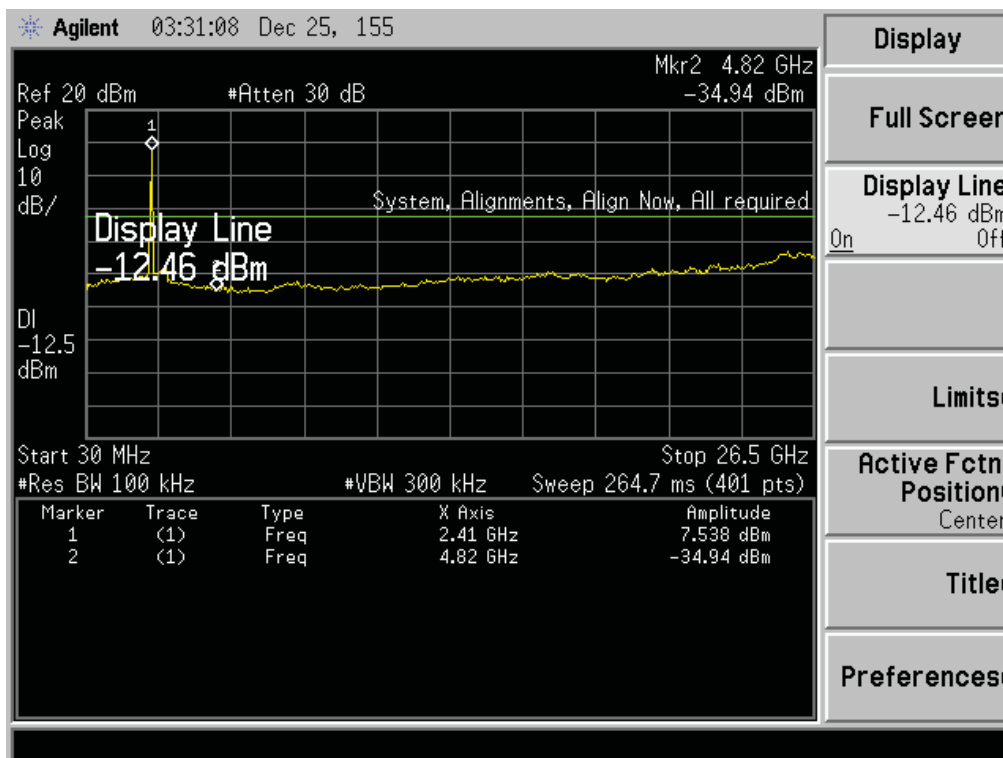

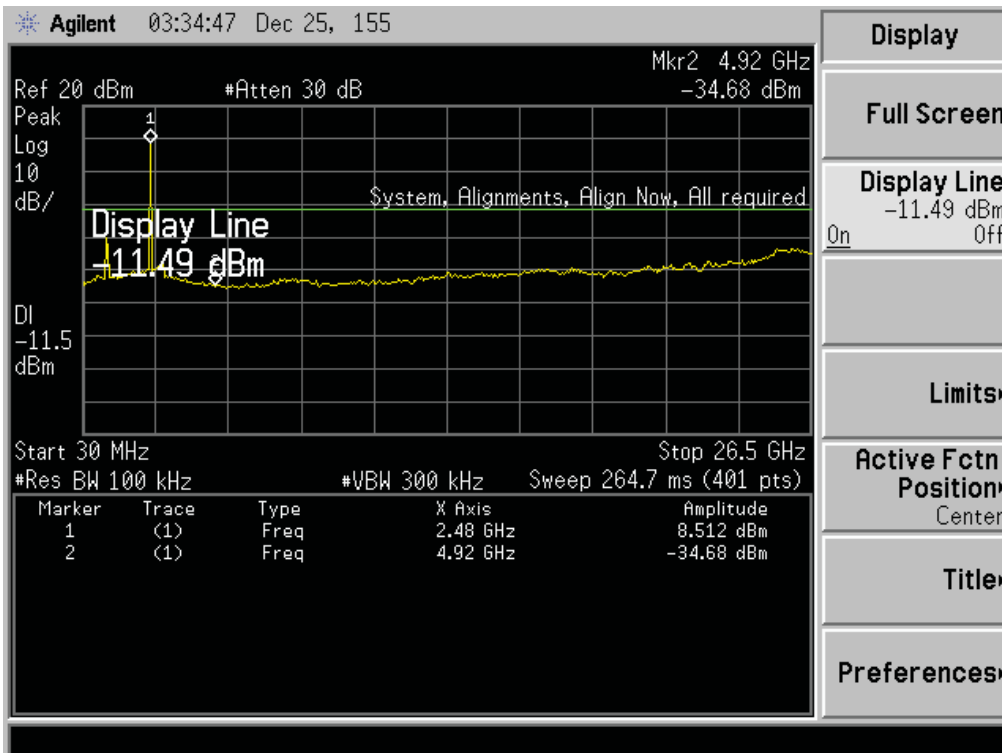
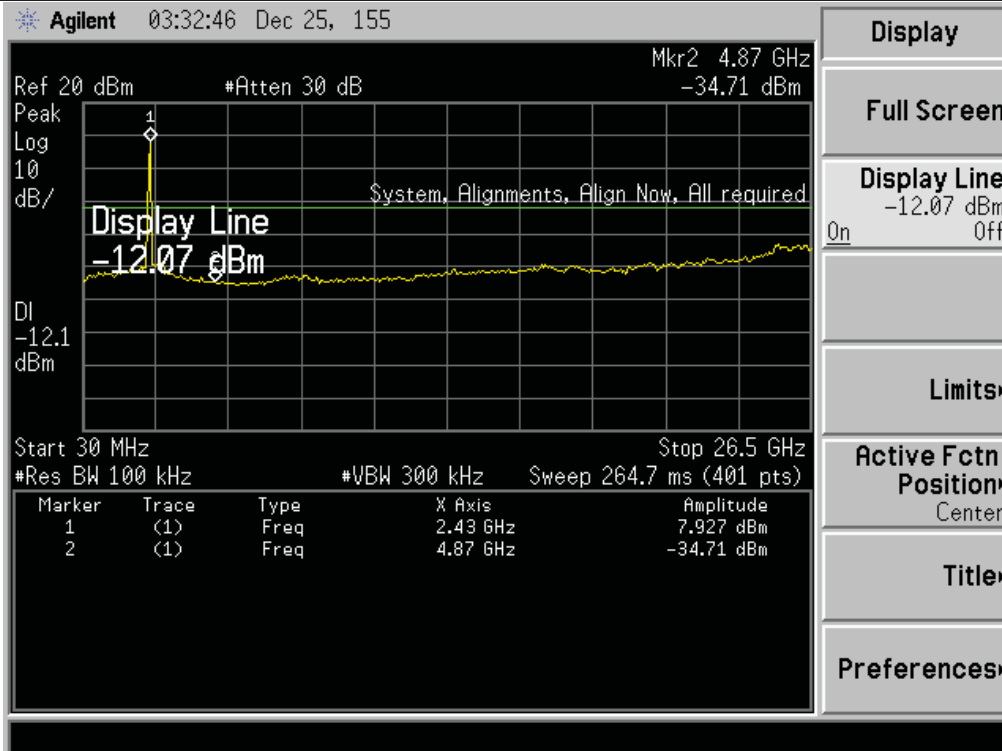

802.11 g Mode

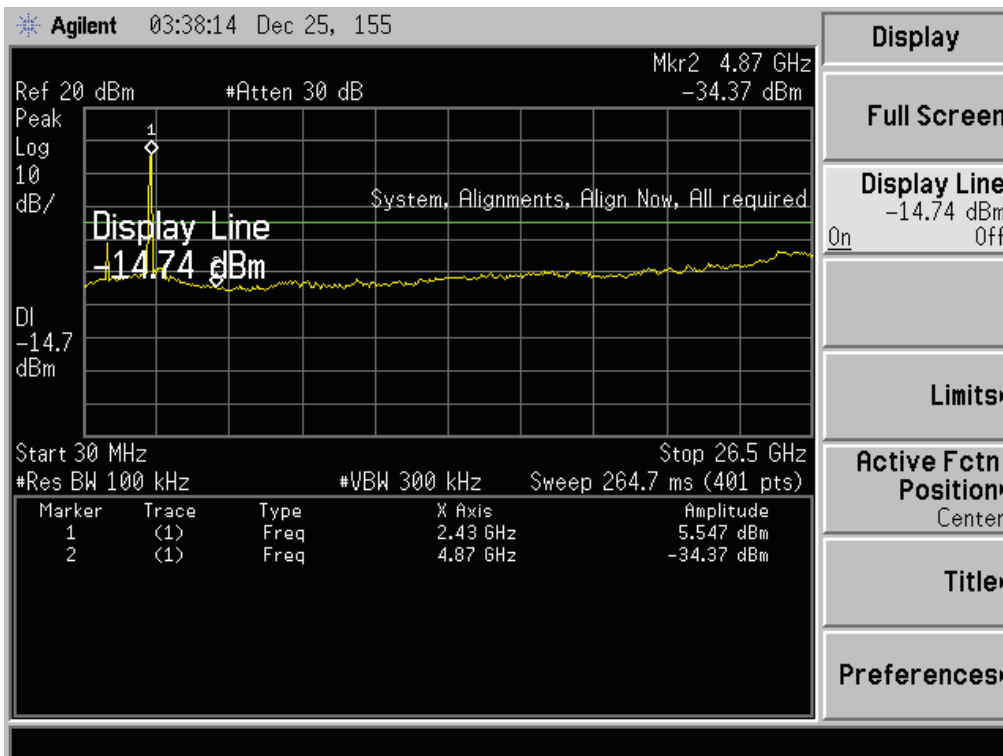
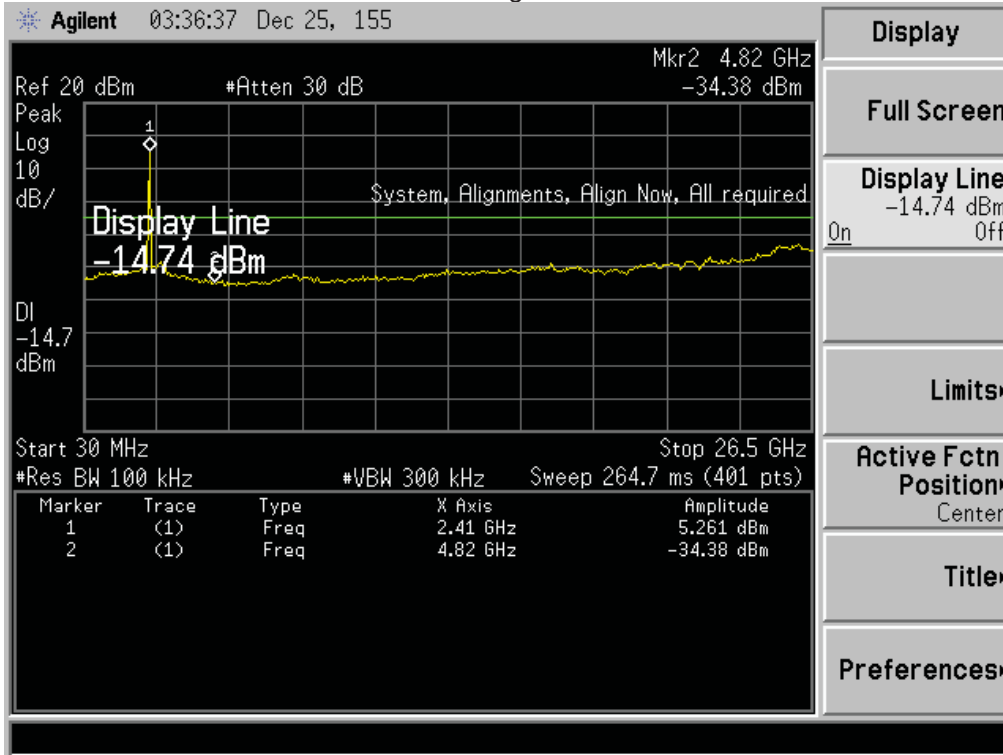

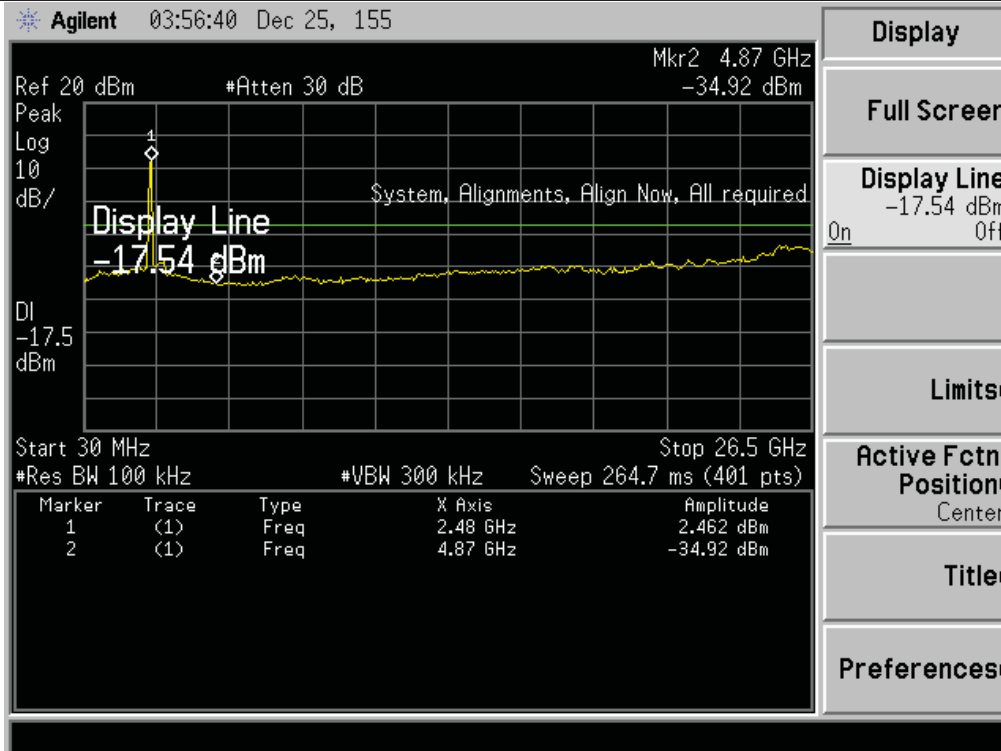

802.11 n20 Mode

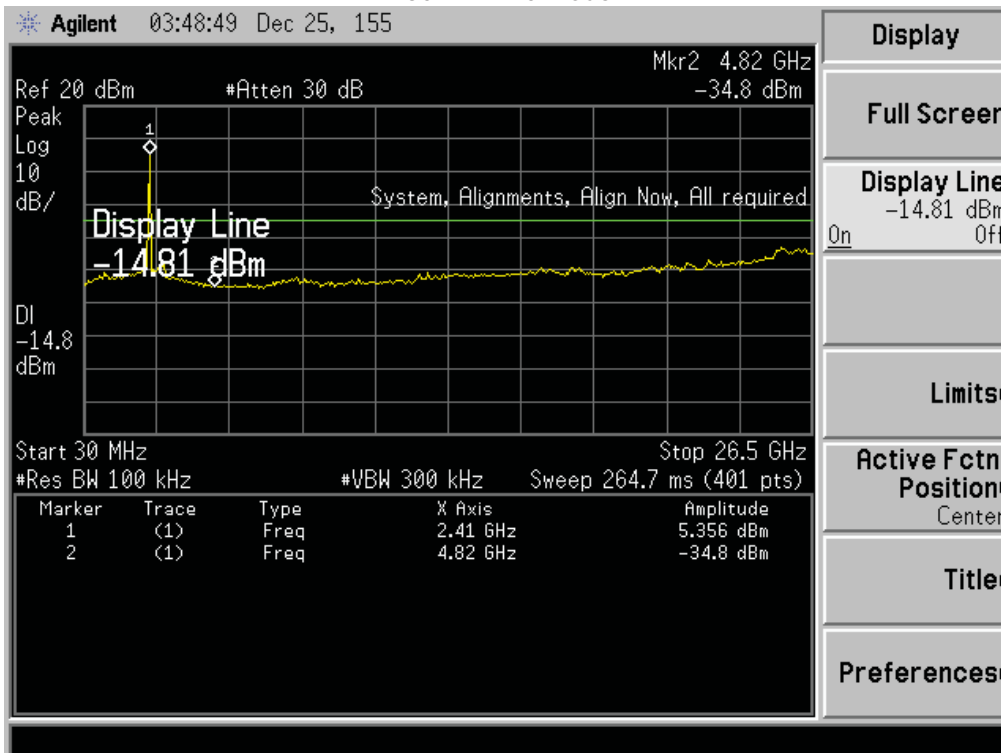

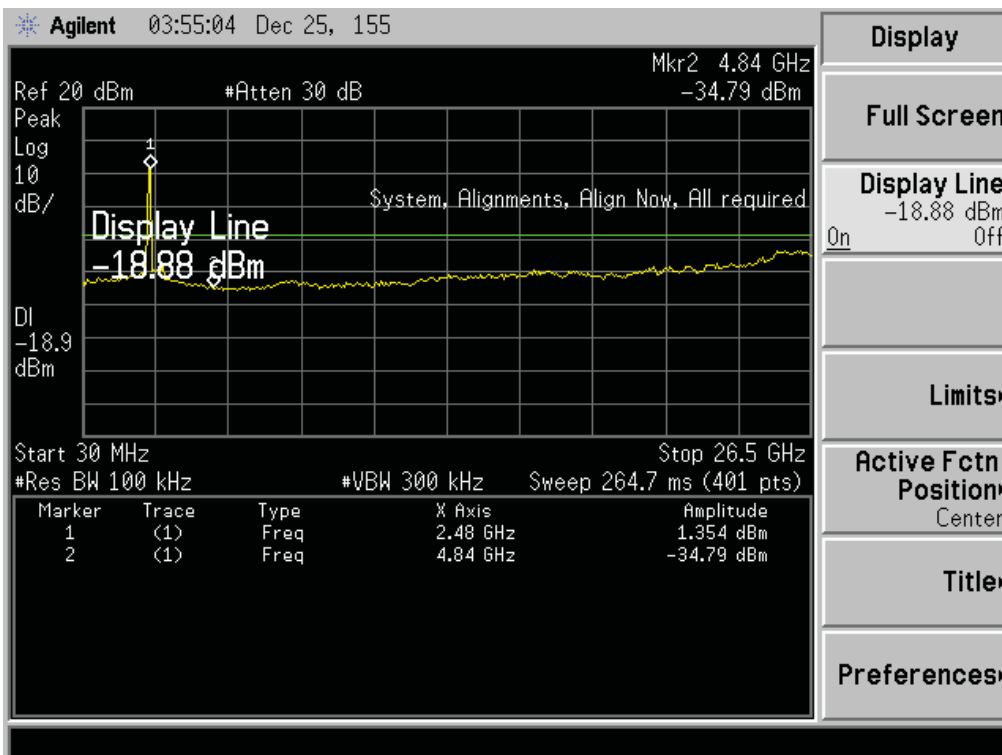
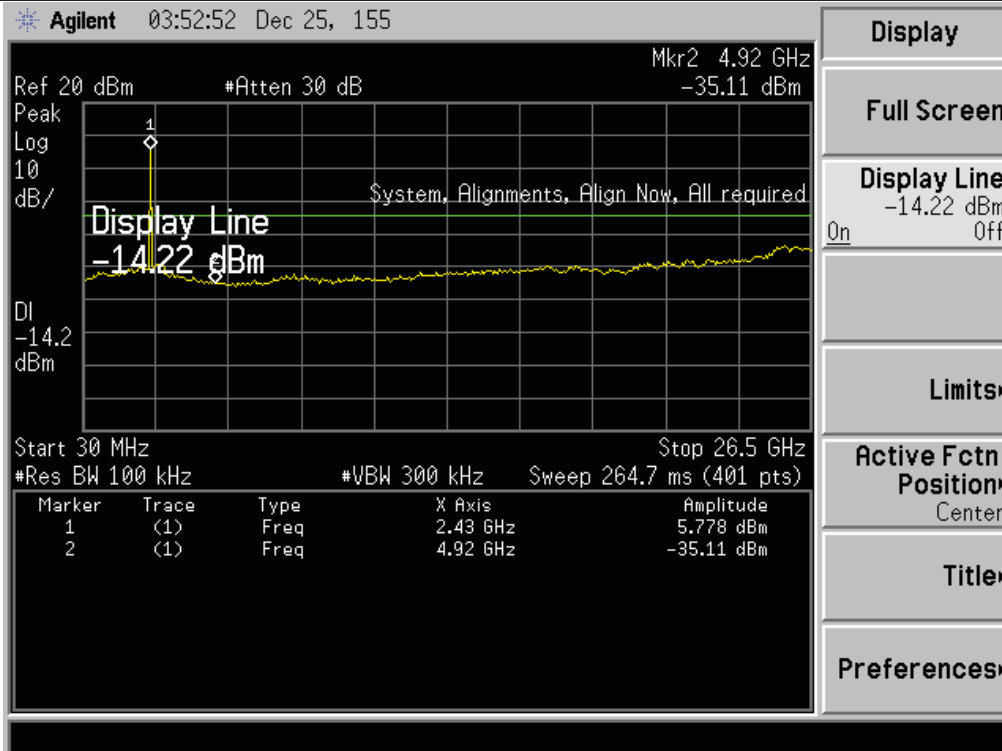

10. Antenna Requirements

10.1 Limit

For intentional device, according to FCC 47 CFR Section 15.203, an intentional radiator shall be designed to ensure that no antenna other than that furnished by the responsible party shall be used with the device. And according to FCC 47 CFR Section 15.247 (b), if transmitting antennas of directional gain greater than 6dBi are used, the power shall be reduced by the amount in dB that the directional gain of the antenna exceeds 6dBi.

10.2 Result

The antennas used for this product are built-in undetachable dipole antenna and that no antenna other than that furnished by the responsible party shall be used with the device, the maximum peak gain of the transmit antenna is only 3dBi.

END OF REPORT