

PRINT INSTRUCTIONS: !!! DRAFTr7 !!!

REFERENCE SHEET FOR VS-IDC350-GRY P/N 77-600061-001 REV 1.0 |

INK: BLACK | **MATERIAL:** 20 LB MEAD BOND | **SIZE:** 8.50" X 11.00" SCALE 1:1 |

FOLDS: BI-FOLD VERTICAL, BI-FOLD HORIZONTAL (TO FIT IN BOX)

Vivint Indoor Camera Pro

(VS-IDC350-GRY)

Quick Reference (User Manual — Installation & Operation)

vivint

4931 N 300 W Provo, UT 84604

The Vivint Indoor Camera Pro is a powerful multi-purpose video and audio communication device that can be added to an integrated Vivint Smart Home system, enhancing safety and security by letting the homeowner view a live video stream at both the panel/hub screen and remotely with the mobile app. Activity history in the viewing area can also be accessed via recorded video clips. Additionally, you can engage in two-way talk with anyone at the camera with the call initiated from either the app or the camera itself; as well as receive notifications when the camera detects a person in customized detection zones. The LED light on the front of the camera indicates real-time function and status. The Vivint Indoor Camera Pro is an indoor use only device.

Professionally installed by a Vivint technician (or customer DIY), the indoor camera is added to the system either through WPS, Wi-Fi Connect, or NFC. The camera can be installed on any flat surface or mounted on a wall with the wall mount back plate, and the field-of-view configured with the camera's full-motion (tilt and swivel) hinge and base.

Additional features include: Night vision with IR LEDs; 155° x 80° FOV (field of view); 1080p HD; Pinch-to-zoom video; Person-triggered notifications; Micro SD card for 24/7 playback DVR; Complete control and configuration via the app.

This document includes a product description, illustrations, basic operation / user functionality overview, and installation instructions; as well as technical specifications, standards listings, and regulatory compliance references.



Installation Instructions

Installing the indoor camera essentially involves selecting the location, mounting the camera, applying power, initiating the setup procedure and then following prompts. The camera can be installed by a Vivint Field Service Pro (FSP)/technician or the homeowner. The technician should carefully read all of these steps in order to ensure a successful installation and optimal performance. For additional information, refer to the *Field Service Pros* website.

To install the indoor camera, follow these steps:

- Determine where to place the camera inside the home, consulting with the homeowner.
IMPORTANT: Do NOT install outdoors. The IDCPro is an indoor use only device.
- Locate the nearest unswitched power outlet and plug in the power supply adapter.
- To install the camera on a flat surface: Place the camera in the desired location, and connect the camera's power cable to the cable coming from the power supply.
- To install the camera on a wall: Attach the wall mount back plate with standard screws (use anchors if necessary), place the base of the camera on the back plate pushing down until it latches securely, and then connect the power cables.
- Verify power is present. The LED light will illuminate. (See LED descriptions.)
- To pair the camera to the system: First, at the panel, tap the menu icon (...) in the bottom right corner > tap **Software version** > enter PIN code **2203** > tap **Smart Home devices** > **Cameras** > and then tap **Add camera**. Next, use one of these methods to pair.
 - For WPS pairing:** Tap **WPS Pro**, wait for the "listening for device" message, then go to the camera, press the top button, and follow the prompts until it shows online.
 - For Wi-Fi Connect pairing:** Tap **Wi-Fi Connect**, wait for the panel to find the camera device, then select the camera, tap **Add**, and wait for the camera to show online.
 - For NFC pairing (Note: Use only before installing!):** Tap **NFC**, align the bottom right of the front of the camera with the white light on the panel and hold until pairing is complete. Then install, power on, and wait for the camera to show online.
- Verify that you can view live video at the panel and with the app.

Indoor Camera Pro (front view) —

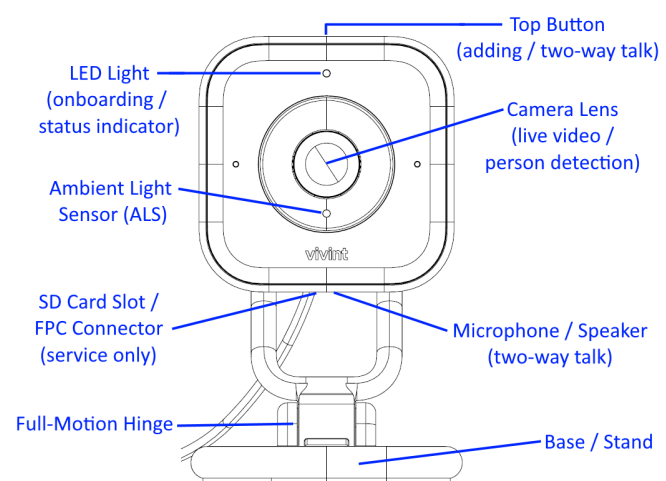

Wall Mount Back Plate and Camera Base (bottom view) —

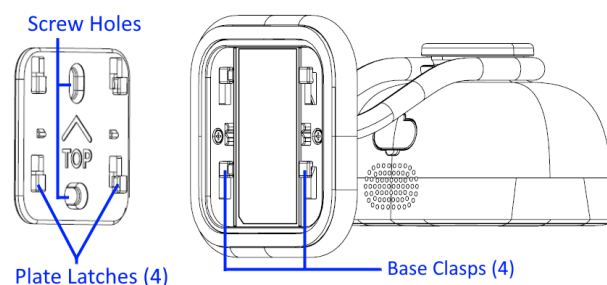

Operation Overview / User Functionality

Once the indoor camera is up and running — similar to other Vivint cameras — the user can perform the following functions at the panel and via the app. For detailed instructions, refer the homeowner to the online Help resources (articles and video tutorials) at the *Vivint Support* website.

- View a live video feed
- View recorded video clips
- Engage in two-way talk conversations
- Receive person detection notifications

Additionally, for camera management and configuration tasks, at the **Devices > Cameras** settings page, the user can:

- Adjust person detection & video settings (app only)
- Reboot the camera
- Delete the camera

Technical / Hardware Specifications

| | |
|---------------------------|--|
| Vivint Part Number (P/N) | VS-IDC350-GRY |
| Model Number (M/N) | CM07 |
| Color | Dark Gray |
| Weight | 1.05 lbs. (approx.) |
| Dimensions | 10.7 (h) x 6.6 (w) x 6.6 (d) cm / 4.2 (h) x 2.6 (w) x 2.6 (d) in |
| Power Usage | 12V DC 1.5A min. |
| AC Adapter | Input: 100-240V @ 50-60Hz AC, 0.2A Output: 12V DC, 1.5A |
| Camera Lens | 1/3", 4-megapixel sensor |
| Video Resolution | Full HD 1080p |
| FOV (Field of View) | 153° diagonal (vertical and horizontal) |
| Night Vision | 3 high-powered IR LEDs (850nm) with IR cut filter |
| Micro SD Card | 64GB micro SD card, onboard DVR support (local storage) |
| Audio | Built-in speaker and microphone |
| Connectivity | Wi-Fi connection: WLAN 2.4GHz/5GHz; 802.11 b/g/n |
| Bandwidth | 1 Mbps upload recommended |
| Environmental Temperature | -4°F to 113°F (-20°C to 45°C) |
| Weatherproofing | Yes (IP33, with UV protection) |

Standards Certifications and Listings

| | |
|---------|---|
| FCC | 47CFR Part 2.1091; 47CFR Part 15 Subpart B, Class B; Subpart C |
| FCC ID: | 2AAAS-CM07 |

*For complete regulatory compliance information, go to: vivint.com/legal/fcc

Indoor Camera Pro (back view) —

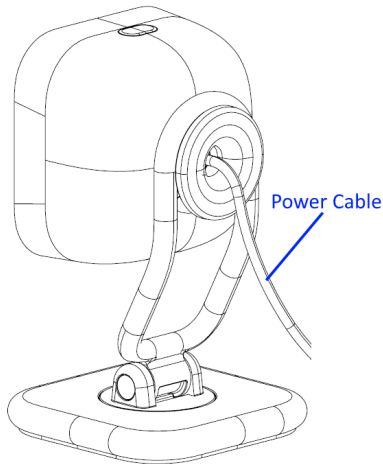

Power Supply Adapter —



Power Cable Barrel Connectors —



What the LED Light Colors Mean

The indoor camera has an LED light above the lens that illuminates different colors in order to indicate various functions and status, as described below.

- **Green (Breathing)** — Booting up, AP mode, ready to pair/connect
- **Green (Blinking)** — WPS connection in progress (configuration)
- **Green (Fast Blinking)** — WPS connection success
- **Red (Solid)** — WPS connection failure
- **White (Solid)** — Camera online
- **Blue (Solid)** — Two-way talk
- **Blue (Blinking)** — Updating firmware
- **Red (Blinking)** — Factory reset (press and hold)

Troubleshooting Tips

Possible failures with the indoor camera and what to do in order to resolve:

- **Camera is not adding (learning in) —**
 - ✓ Power cycle the camera
 - ✓ Factory reset the camera (press & hold the top button for 10-15 sec)
 - ✓ Reset the panel/hub network module
 - ✓ Reboot the panel/hub
- **Camera is offline —**
 - ✓ Verify the camera is receiving power
 - ✓ Power cycle the camera
 - ✓ Factory reset the camera (press & hold the top button for 10-15 sec)
- **Two-way talk is not working —**
 - ✓ Make sure the button is being pressed when talking
 - ✓ Verify the network upload speed is sufficient
 - ✓ Power cycle the camera
 - ✓ Reboot the panel/hub

Wireless Product Notice

Wireless communications hardware provides reliable communication; however, there are some limitations which must be observed.

- The transmitters are required to comply with all applicable wireless rules and regulations. As such, they have limited transmitter power and limited range.
- Wireless signals may be blocked by radio signals that occur on or near the wireless operating frequencies.

FCC Regulatory Compliance Statement*

CAUTION: Changes or modifications not expressly approved by the party responsible for compliance could void the user's authority to operate the equipment.

This device complies with Part 15 of the FCC Rules. Operation is subject to the following two conditions:

1. This device may not cause harmful interference; and
2. This device must accept any interference received, including interference that may cause undesired operation.

This equipment has been tested and found to comply with the limits for a Class B digital device, pursuant to Part 15 of the FCC Rules. These limits are designed to provide reasonable protection against harmful interference in a residential installation. This equipment generates, uses, and can radiate radio frequency energy and, if not installed and used in accordance with the instructions, may cause harmful interference to radio communications. However, there is no guarantee that interference will not occur in a particular installation. If this equipment does cause harmful interference to radio or television reception, which can be determined by turning the equipment off and on, the user is encouraged to try to correct the interference by one or more of the following measures:

- Reorient or relocate the receiving antenna.
- Increase the separation between the equipment and receiver.
- Connect the equipment into an outlet on a circuit different from that to which the receiver is connected.
- Consult the dealer or an experienced radio/TV technician for help.

FCC (U.S.) Radiation Exposure Statement: This equipment complies with FCC radiation exposure limits set forth for an uncontrolled environment. This equipment should be installed and operated with minimum distance 20 cm (7.9 in) between the radiator and your body.