

EMC Test Report

Application for Grant of Equipment Authorization

FCC Part 15, Subpart E

Model: Model 1520

FCC ID: 2AAAS-CE03

APPLICANT: Vivint Wireless
3945 Freedom Circle, Suite 150
Santa Clara, CA 95054

TEST SITE(S): National Technical Systems - Silicon Valley
41039 Boyce Road.
Fremont, CA. 94538-2435

IC SITE REGISTRATION #: 2845B-3; 2845B-4, 2845B-5, 2845B-7

REPORT DATE: February 5, 2015

REISSUE DATE: March 10, 2015

FINAL TEST DATES: September 3, October 27, 28, 29, 30 and 31,
November 3 and 6 and December 10, 12, 15 and
16, 2014

TOTAL NUMBER OF PAGES: 162

PROGRAM MGR /
TECHNICAL REVIEWER:



Mark E Hill
Staff Engineer

QUALITY ASSURANCE DELEGATE /
FINAL REPORT PREPARER:

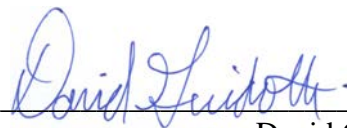

David Guidotti
Senior Technical Writer



National Technical Systems - Silicon Valley is accredited by the A2LA, certificate number 0214.26, to perform the test(s) listed in this report, except where noted otherwise. This report and the information contained herein represent the results of testing test articles identified and selected by the client performed to specifications and/or procedures selected by the client. National Technical Systems (NTS) makes no representations, expressed or implied, that such testing is adequate (or inadequate) to demonstrate efficiency, performance, reliability, or any other characteristic of the articles being tested, or similar products. This report should not be relied upon as an endorsement or certification by NTS of the equipment tested, nor does it represent any statement whatsoever as to its merchantability or fitness of the test article, or similar products, for a particular purpose. This report shall not be reproduced except in full

REVISION HISTORY

Rev#	Date	Comments	Modified By
-	February 5, 2015	First release	
1	March 9, 2015	A justification was added for below 1 GHz configuration	MEH
2	March 10, 2015	Fixed typo in summary of results	MEH

TABLE OF CONTENTS

REVISION HISTORY	2
TABLE OF CONTENTS	3
SCOPE.....	4
OBJECTIVE	4
STATEMENT OF COMPLIANCE.....	5
DEVIATIONS FROM THE STANDARDS.....	5
TEST RESULTS SUMMARY	6
UNII / LELAN DEVICES	6
GENERAL REQUIREMENTS APPLICABLE TO ALL BANDS.....	8
MEASUREMENT UNCERTAINTIES.....	9
EQUIPMENT UNDER TEST (EUT) DETAILS.....	10
GENERAL.....	10
OTHER EUT DETAILS.....	10
ANTENNA SYSTEM	10
ENCLOSURE.....	10
MODIFICATIONS.....	10
SUPPORT EQUIPMENT.....	11
EUT INTERFACE PORTS	11
EUT OPERATION	11
TEST SITE.....	12
GENERAL INFORMATION	12
CONDUCTED EMISSIONS CONSIDERATIONS	12
RADIATED EMISSIONS CONSIDERATIONS	12
MEASUREMENT INSTRUMENTATION	13
RECEIVER SYSTEM	13
INSTRUMENT CONTROL COMPUTER	13
LINE IMPEDANCE STABILIZATION NETWORK (LISN).....	13
FILTERS/ATTENUATORS	14
ANTENNAS.....	14
ANTENNA MAST AND EQUIPMENT TURNTABLE.....	14
INSTRUMENT CALIBRATION.....	14
TEST PROCEDURES	15
EUT AND CABLE PLACEMENT	15
CONDUCTED EMISSIONS.....	15
RADIATED EMISSIONS	15
CONDUCTED EMISSIONS FROM ANTENNA PORT	19
BANDWIDTH MEASUREMENTS	19
SPECIFICATION LIMITS AND SAMPLE CALCULATIONS	20
CONDUCTED EMISSIONS SPECIFICATION LIMITS: FCC 15.207; FCC 15.107(A), RSS GEN	20
GENERAL TRANSMITTER RADIATED EMISSIONS SPECIFICATION LIMITS	21
FCC 15.407 (A) OUTPUT POWER LIMITS	21
SPURIOUS EMISSIONS LIMITS –UNII AND LELAN DEVICES	21
SAMPLE CALCULATIONS - CONDUCTED EMISSIONS	22
SAMPLE CALCULATIONS - RADIATED EMISSIONS.....	22
SAMPLE CALCULATIONS - FIELD STRENGTH TO EIRP CONVERSION.....	23
APPENDIX A TEST EQUIPMENT CALIBRATION DATA	24
APPENDIX B TEST DATA	27
END OF REPORT	162

SCOPE

An electromagnetic emissions test has been performed on the Vivint Wireless model Model 1520, pursuant to the following rules:

FCC Part 15, Subpart E requirements for UNII Devices

Conducted and radiated emissions data has been collected, reduced, and analyzed within this report in accordance with measurement guidelines set forth in the following reference standards and as outlined in National Technical Systems - Silicon Valley test procedures:

ANSI C63.10-2009

FCC General UNII Test Procedures KDB789033

The intentional radiator above has been tested in a simulated typical installation to demonstrate compliance with the relevant Industry Canada performance and procedural standards.

Final system data was gathered in a mode that tended to maximize emissions by varying orientation of EUT, orientation of power and I/O cabling, antenna search height, and antenna polarization.

Every practical effort was made to perform an impartial test using appropriate test equipment of known calibration. All pertinent factors have been applied to reach the determination of compliance.

OBJECTIVE

The primary objective of the manufacturer is compliance with the regulations outlined in the previous section.

Prior to marketing in the USA, all unlicensed transmitters and transceivers require certification. Receive-only devices operating between 30 MHz and 960 MHz are subject to either certification or a manufacturer's declaration of conformity, with all other receive-only devices exempt from the technical requirements.

Certification is a procedure where the manufacturer submits test data and technical information to a certification body and receives a certificate or grant of equipment authorization upon successful completion of the certification body's review of the submitted documents. Once the equipment authorization has been obtained, the label indicating compliance must be attached to all identical units, which are subsequently manufactured.

Maintenance of compliance is the responsibility of the manufacturer. Any modification of the product which may result in increased emissions should be checked to ensure compliance has been maintained (i.e., printed circuit board layout changes, different line filter, different power supply, harnessing or I/O cable changes, etc.).

STATEMENT OF COMPLIANCE

The tested sample of Vivint Wireless model Model 1520 complied with the requirements of the following regulations:

FCC Part 15, Subpart E requirements for UNII Devices

Maintenance of compliance is the responsibility of the manufacturer. Any modifications to the product should be assessed to determine their potential impact on the compliance status of the device with respect to the standards detailed in this test report.

The test results recorded herein are based on a single type test of Vivint Wireless model Model 1520 and therefore apply only to the tested sample. The sample was selected and prepared by Venkat Kalkunte of Vivint Wireless.

DEVIATIONS FROM THE STANDARDS

No deviations were made from the published requirements listed in the scope of this report.

TEST RESULTS SUMMARY

UNII / LELAN DEVICES

Operation in the 5.15 – 5.25 GHz Band

FCC Rule Part	RSS Rule Part	Description	Measured Value / Comments	Limit / Requirement	Result
15.407(a) (1)(iv)	-	Output Power	n20: 20.5dBm (112.7 mW) n40: 20.7dBm (118.3 mW) ac80: 15.4dBm (34.8 mW)	24 dBm / 250mW (eirp < 30dBm)	Complies
	-	Power Spectral Density	n20: 7.5 dBm/MHz n40: 4.6 dBm/MHz ac80: -3.0 dBm/MHz	11 dBm/MHz	Complies

Operation in the 5.25 – 5.35 GHz Band

FCC Rule Part	RSS Rule Part	Description	Measured Value / Comments	Limit / Requirement	Result (margin)
15.407(a) (2)	-	26dB Bandwidth	n20: 24.5MHz n40: 41.5MHz ac80: 80.97MHz	N/A – limits output power if < 20MHz	N/A
15.407(a) (2)	-	Output Power	n20: 20.5dBm (112.8 mW) n40: 20.9dBm (124.0 mW) ac80: 17.9dBm (62.2 mW) (Max eirp: 29.9 dBm (987.2 mW))	24 dBm / 250mW (eirp < 30dBm)	Complies
			15.407(a) (2)		

Operation in the 5.47 – 5.725 GHz Band

FCC Rule Part	RSS Rule Part	Description	Measured Value / Comments	Limit / Requirement	Result (margin)
15.407(a) (2)	-	26dB Bandwidth	n20: 24.5MHz n40: 41.5MHz ac80: 80.97MHz	N/A – limits output power if < 20MHz	N/A
15.407(a) (2)	-	Output Power	n20: 20.96dBm (124.8 mW) n40: 20.8dBm (119 mW) ac80: 18.3dBm (67.4 mW) (Max eirp: 29.97 dBm (993.47 mW))	24 dBm / 250mW (eirp < 30dBm)	Complies
15.407(a) (2))	-	Power Spectral Density	n20: 7.7 dBm/MHz n40: 5.2 dBm/MHz ac80: 0.9 dBm/MHz	11 dBm/MHz	Complies

Operation in the 5.725 – 5.850 GHz Band

FCC Rule Part	RSS Rule Part	Description	Measured Value / Comments	Limit / Requirement	Result (margin)
15.407(a) (3) / 15.407(e)	-	6dB Bandwidth	n20: 17.6MHz n40: 36.27MHz ac80: 75.69MHz	>500kHz	N/A
15.407(a) (3)	-	Output Power	n20: 23.9dBm (246.1 mW) n40: 24.1dBm (260 mW) ac80: 19.1dBm (81 mW) (Max eirp: 33.2dBm (2.068W))	30 dBm / 1000W (eirp < 36dBm)	Complies
15.407(a) (3))	-	Power Spectral Density	n20: 10.7 dBm/MHz n40: 8.0 dBm/MHz ac80: 0.9 dBm/MHz	30dBm/500kHz (27dBm/MHz)	Complies

Requirements for all U-NII/LELAN bands

FCC Rule Part	RSS Rule Part	Description	Measured Value / Comments	Limit / Requirement	Result
15.407	-	Modulation	Digital Modulation is used	Digital modulation is required	Complies
15.407(b) (5) / 15.209	-	Spurious Emissions	53.9 dB μ V/m @ 11569.9 MHz (-0.1 dB)	Refer to page 21	Complies
15.407 (c)	-	Operation in the absence of information to transmit	Operation is discontinued in the absence of information	Device shall automatically discontinue operation in the absence of information to transmit	Complies
15.407 (g)	-	Frequency Stability	Frequency stability is better than 10ppm	Signal shall remain within the allocated band	Complies
15.407 (h1)	A9.4	Transmit Power Control	TCP mechanism is discussed in the Operational Description	The U-NII device shall have the capability to operate with a mean EIRP value lower than 24dBm (250mW)	Complies
15.407 (h2)	A9.4	Dynamic frequency Selection (device with radar detection)	Refer to separate test report, reference R97286	Threshold -62dBm (-64dBm if eirp > 200mW) Channel Availability Check > 60s Channel closing transmission time < 260ms Channel move time < 10s Non occupancy period > 30minutes	Complies

GENERAL REQUIREMENTS APPLICABLE TO ALL BANDS

FCC Rule Part	RSS Rule part	Description	Measured Value / Comments	Limit / Requirement	Result (margin)
15.203	-	RF Connector	Antenna is integral	Unique or integral antenna required	Complies
15.207	-	AC Conducted Emissions	46.7 dB μ V @ 14.772 MHz (-3.3 dB)	Refer to page 20	Complies
15.247 (b) (5) / 15.407 (f)	-	RF Exposure Requirements	Refer to MPE calculations in separate exhibit	Refer to OET 65, FCC Part 1 and RSS 102	Complies

MEASUREMENT UNCERTAINTIES

ISO/IEC 17025 requires that an estimate of the measurement uncertainties associated with the emissions test results be included in the report. The measurement uncertainties given below are based on a 95% confidence level and were calculated in accordance with UKAS document LAB 34.

Measurement Type	Measurement Unit	Frequency Range	Expanded Uncertainty
RF power, conducted (power meter)	dBm	25 to 7000 MHz	± 0.52 dB
RF power, conducted (Spectrum analyzer)	dBm	25 to 7000 MHz	± 0.7 dB
Conducted emission of transmitter	dBm	25 to 26500 MHz	± 0.7 dB
Conducted emission of receiver	dBm	25 to 26500 MHz	± 0.7 dB
Radiated emission (substitution method)	dBm	25 to 26500 MHz	± 2.5 dB
Radiated emission (field strength)	dB μ V/m	25 to 1000 MHz	± 3.6 dB
		1000 to 40000 MHz	± 6.0 dB
Conducted Emissions (AC Power)	dB μ V	0.15 to 30 MHz	± 2.4 dB

EQUIPMENT UNDER TEST (EUT) DETAILS

GENERAL

The Vivint Wireless model Model 1520 is a 5GHz 802.11 4x4 client device. The EUT would normally be pole or wall mounted. For testing, it was placed on a tabletop. The EUT is powered via POE connection.

The sample was received on September 3, 2014 and tested on September 3, October 27, 28, 29, 30 and 31, November 3 and 6 and December 10, 12, 15 and 16, 2014. The EUT consisted of the following component(s):

Company	Model	Description	Serial Number	FCC ID
Vivint Wireless	1520	5GHz 802.11 4x4 radio	-	TBD

OTHER EUT DETAILS

The following EUT details should be noted:

20/40MHz/80MHz

FCC "New" 5GHz rules

11a legacy data rates not supported

HT20 – MCS0 thru MCS7, VHT0 (min of 2 spatial stream, max of 4)

HT40 – MCS0 thru MCS7, VHT0, VHT1 (min of 2 spatial stream, max of 4)

AC80 – VHT0 thru VHT9 (min of 2 spatial stream, max of 4)

DFS Client device

4x4 only operation (does not support 3Tx, 2Tx or 1Tx operational modes)

Antenna: 6dBi

Non-point-to-point system

Beamforming (2 pairs) supported

ANTENNA SYSTEM

The antenna system consists of 4 element panel antenna integral to the device.

ENCLOSURE

The EUT enclosure is primarily constructed of uncoated plastic. It measures approximately 32 cm wide by 8 cm deep by 32 cm high.

MODIFICATIONS

No modifications were made to the EUT during the time the product was at NTS Silicon Valley.

SUPPORT EQUIPMENT

No local support equipment was used during testing.

The following equipment was used as remote support equipment for emissions testing:

Company	Model	Description	Serial Number	FCC ID
-	PSE802G	POE Injector		-
		Laptop Computer		

EUT INTERFACE PORTS

The I/O cabling configuration during testing was as follows:

Port	Connected To	Description	Cable(s)	
			Shielded or Unshielded	Length(m)
POE	POE Injector	CAT5	Unshielded	5m
USB	Not Connected	-	-	-

Additional on Support Equipment

Port	Connected To	Description	Cable(s)	
			Shielded or Unshielded	Length(m)
POE Injector	Laptop	CAT5	Unshielded	2m

EUT OPERATION

During emissions testing the EUT was configured to continuously transmit at the noted channel and power level. All transmissions were 4Tx with beamforming active.

TEST SITE

GENERAL INFORMATION

Final test measurements were taken at the test sites listed below. Pursuant to section 2.948 of the FCC's Rules and section 3.3 of RSP-100, construction, calibration, and equipment data has been filed with the Commission and with industry Canada.

Site	Designation / Registration Numbers		Location
	FCC	Canada	
Chamber 3	US0027	2845B-3	41039 Boyce Road Fremont, CA 94538-2435
Chamber 4	US0027	2845B-4	
Chamber 5	US0027	2845B-5	
Chamber 7	US0027	2845B-7	

ANSI C63.4 recommends that ambient noise at the test site be at least 6 dB below the allowable limits. Ambient levels are below this requirement. The test site(s) contain separate areas for radiated and conducted emissions testing. Considerable engineering effort has been expended to ensure that the facilities conform to all pertinent requirements of ANSI C63.4.

CONDUCTED EMISSIONS CONSIDERATIONS

Conducted emissions testing is performed in conformance with ANSI C63.10. Measurements are made with the EUT connected to the public power network through a nominal, standardized RF impedance, which is provided by a line impedance stabilization network, known as a LISN. A LISN is inserted in series with each current-carrying conductor in the EUT power cord.

RADIATED EMISSIONS CONSIDERATIONS

The FCC has determined that radiation measurements made in a shielded enclosure are not suitable for determining levels of radiated emissions. Radiated measurements are performed in an open field environment or in a semi-anechoic chamber. The test sites are maintained free of conductive objects within the CISPR defined elliptical area incorporated in ANSI C63.4 guidelines and meet the Normalized Site Attenuation (NSA) requirements of ANSI C63.4.

MEASUREMENT INSTRUMENTATION

RECEIVER SYSTEM

An EMI receiver as specified in CISPR 16-1-1 is used for emissions measurements. The receivers used can measure over the frequency range of 9 kHz up to 2000 MHz. These receivers allow both ease of measurement and high accuracy to be achieved. The receivers have Peak, Average, and CISPR (Quasi-peak) detectors built into their design so no external adapters are necessary. The receiver automatically sets the required bandwidth for the CISPR detector used during measurements. If the repetition frequency of the signal being measured is below 20Hz, peak measurements are made in lieu of Quasi-Peak measurements.

For measurements above the frequency range of the receivers, a spectrum analyzer is utilized because it provides visibility of the entire spectrum along with the precision and versatility required to support engineering analysis. Average measurements above 1000MHz are performed on the spectrum analyzer using the linear-average method with a resolution bandwidth of 1 MHz and a video bandwidth of 10 Hz, unless the signal is pulsed in which case the average (or video) bandwidth of the measuring instrument is reduced to onset of pulse desensitization and then increased.

INSTRUMENT CONTROL COMPUTER

The receivers utilize either a Rohde & Schwarz EZM Spectrum Monitor/Controller or contain an internal Spectrum Monitor/Controller to view and convert the receiver measurements to the field strength at an antenna or voltage developed at the LISN measurement port, which is then compared directly with the appropriate specification limit. This provides faster, more accurate readings by performing the conversions described under Sample Calculations within the Test Procedures section of this report. Results are printed in a graphic and/or tabular format, as appropriate. A personal computer is used to record all measurements made with the receivers.

The Spectrum Monitor provides a visual display of the signal being measured. In addition, the controller or a personal computer run automated data collection programs which control the receivers. This provides added accuracy since all site correction factors, such as cable loss and antenna factors are added automatically.

LINE IMPEDANCE STABILIZATION NETWORK (LISN)

Line conducted measurements utilize a fifty microhenry Line Impedance Stabilization Network as the monitoring point. The LISN used also contains a 250 uH CISPR adapter. This network provides for calibrated radio frequency noise measurements by the design of the internal low pass and high pass filters on the EUT and measurement ports, respectively.

FILTERS/ATTENUATORS

External filters and precision attenuators are often connected between the receiving antenna or LISN and the receiver. This eliminates saturation effects and non-linear operation due to high amplitude transient events.

ANTENNAS

A loop antenna is used below 30 MHz. For the measurement range 30 MHz to 1000 MHz either a combination of a biconical antenna and a log periodic or a bi-log antenna is used. Above 1000 MHz, horn antennas are used. The antenna calibration factors to convert the received voltage to an electric field strength are included with appropriate cable loss and amplifier gain factors to determine an overall site factor, which is then programmed into the test receivers or incorporated into the test software.

ANTENNA MAST AND EQUIPMENT TURNTABLE

The antennas used to measure the radiated electric field strength are mounted on a non-conductive antenna mast equipped with a motor-drive to vary the antenna height. Measurements below 30 MHz are made with the loop antenna at a fixed height of 1m above the ground plane.

ANSI C63.10 specifies that the test height above ground for table mounted devices shall be 80 centimeters. Floor mounted equipment shall be placed on the ground plane if the device is normally used on a conductive floor or separated from the ground plane by insulating material from 3 to 12 mm if the device is normally used on a non-conductive floor as specified in ANSI C63.4. During radiated measurements, the EUT is positioned on a motorized turntable in conformance with this requirement.

INSTRUMENT CALIBRATION

All test equipment is regularly checked to ensure that performance is maintained in accordance with the manufacturer's specifications. All antennas are calibrated at regular intervals with respect to tuned half-wave dipoles. An exhibit of this report contains the list of test equipment used and calibration information.

TEST PROCEDURES

EUT AND CABLE PLACEMENT

The regulations require that interconnecting cables be connected to the available ports of the unit and that the placement of the unit and the attached cables simulate the worst case orientation that can be expected from a typical installation, so far as practicable. To this end, the position of the unit and associated cabling is varied within the guidelines of ANSI C63.10, and the worst-case orientation is used for final measurements.

CONDUCTED EMISSIONS

Conducted emissions are measured at the plug end of the power cord supplied with the EUT. Excess power cord length is wrapped in a bundle between 30 and 40 centimeters in length near the center of the cord. Preliminary measurements are made to determine the highest amplitude emission relative to the specification limit for all the modes of operation. Placement of system components and varying of cable positions are performed in each mode. A final peak mode scan is then performed in the position and mode for which the highest emission was noted on all current carrying conductors of the power cord.

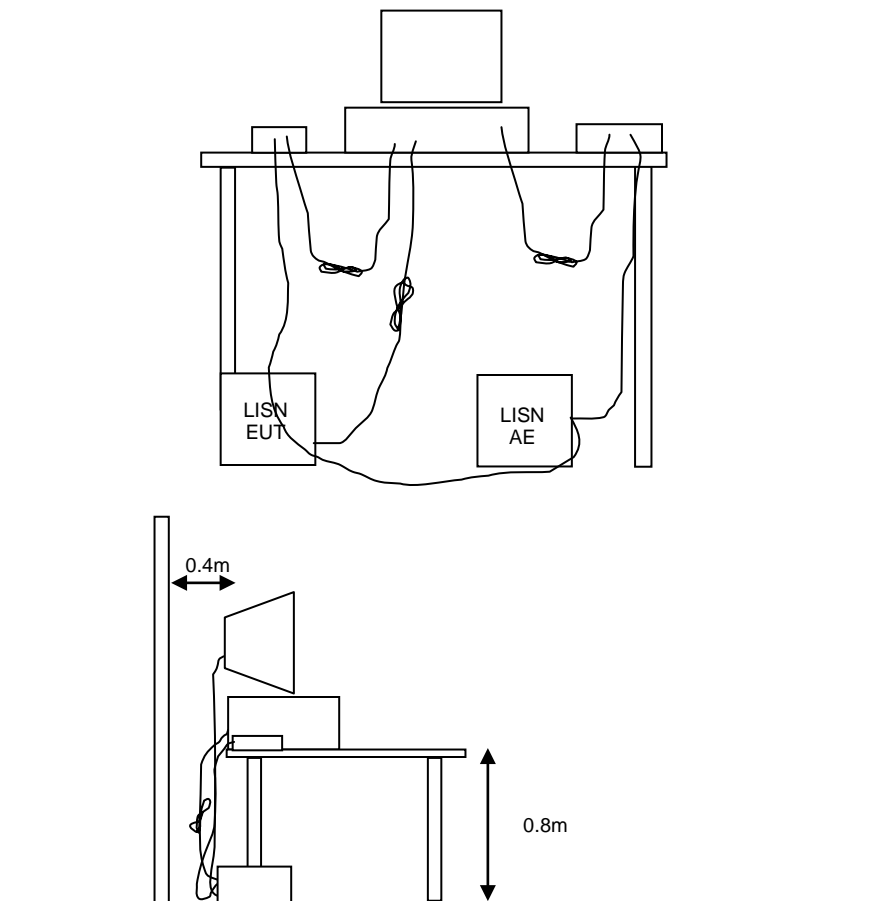

Figure 1 Typical Conducted Emissions Test Configuration

RADIATED EMISSIONS

A preliminary scan of the radiated emissions is performed in which all significant EUT frequencies are identified with the system in a nominal configuration. At least two scans are performed, one scan for each antenna polarization (horizontal and vertical; loop parallel and perpendicular to the EUT). During the preliminary scans, the EUT is rotated through 360°, the antenna height is varied (for measurements above 30 MHz) and cable positions are varied to determine the highest emission relative to the limit. Preliminary scans may be performed in a fully anechoic chamber for the purposes of identifying the frequencies of the highest emissions from the EUT.

A speaker is provided in the receiver to aid in discriminating between EUT and ambient emissions. Other methods used during the preliminary scan for EUT emissions involve scanning with near field magnetic loops, monitoring I/O cables with RF current clamps, and cycling power to the EUT.

Final maximization is a phase in which the highest amplitude emissions identified in the spectral search are viewed while the EUT azimuth angle is varied from 0 to 360 degrees relative to the receiving antenna. The azimuth, which results in the highest emission is then maintained while varying the antenna height from one to four meters (for measurements above 30 MHz, measurements below 30 MHz are made with the loop antenna at a fixed height of 1m). The result is the identification of the highest amplitude for each of the highest peaks. Each recorded level is corrected in the receiver using appropriate factors for cables, connectors, antennas, and preamplifier gain.

When testing above 18 GHz, the receive antenna is located at 1 meter from the EUT and the antenna height is restricted to a maximum of 2.5 meters.

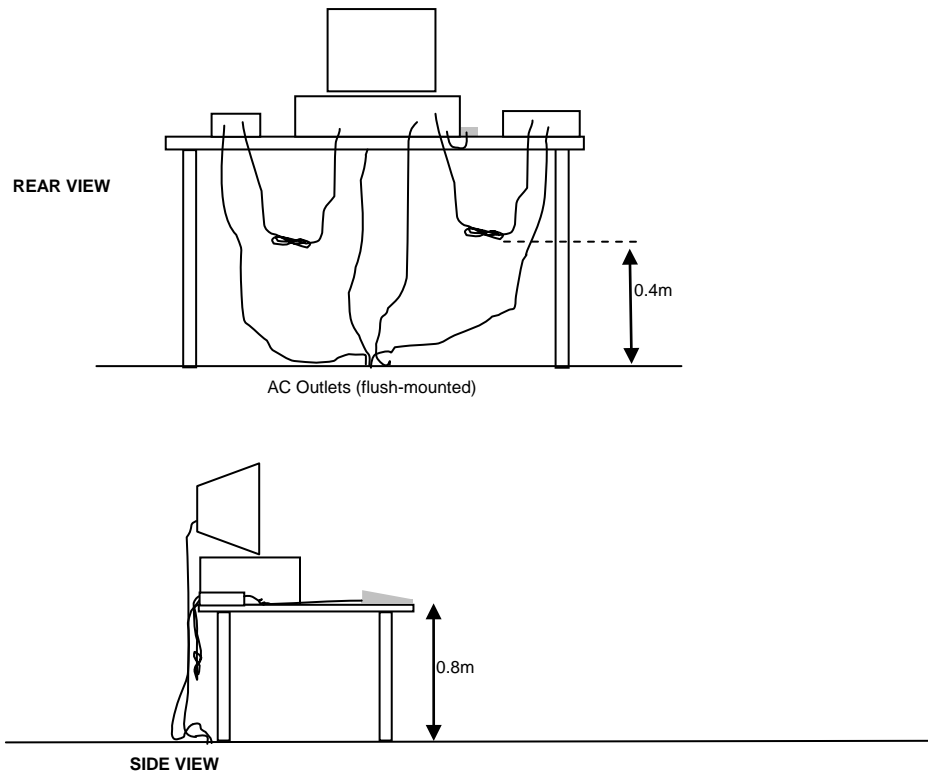

Typical Test Configuration for Radiated Field Strength Measurements

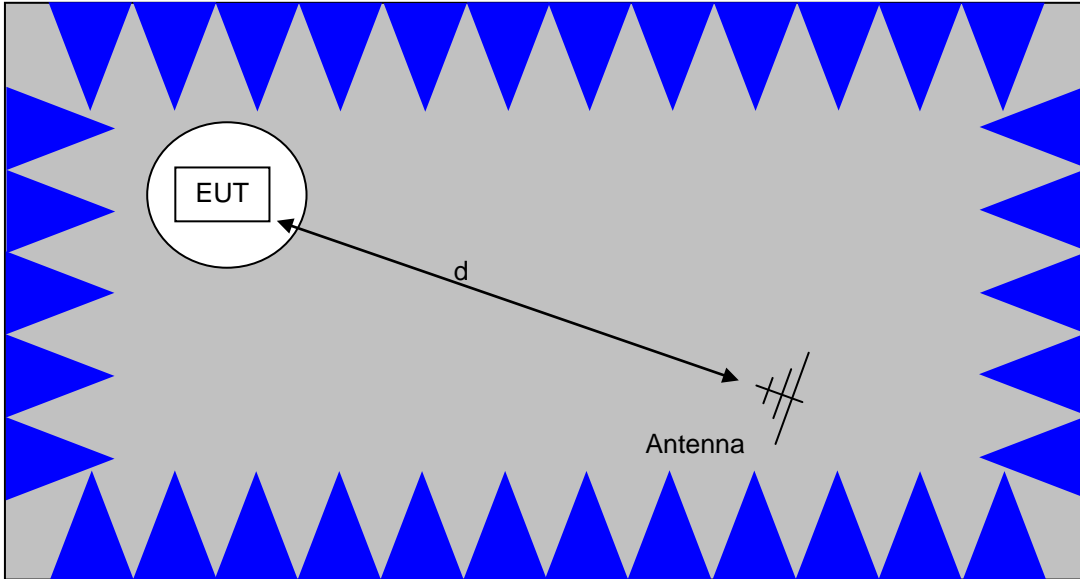

The anechoic materials on the walls and ceiling ensure compliance with the normalized site attenuation requirements of CISPR 16 / CISPR 22 / ANSI C63.4 for an alternate test site at the measurement distances used.

Floor-standing equipment is placed on the floor with insulating supports between the unit and the ground plane.

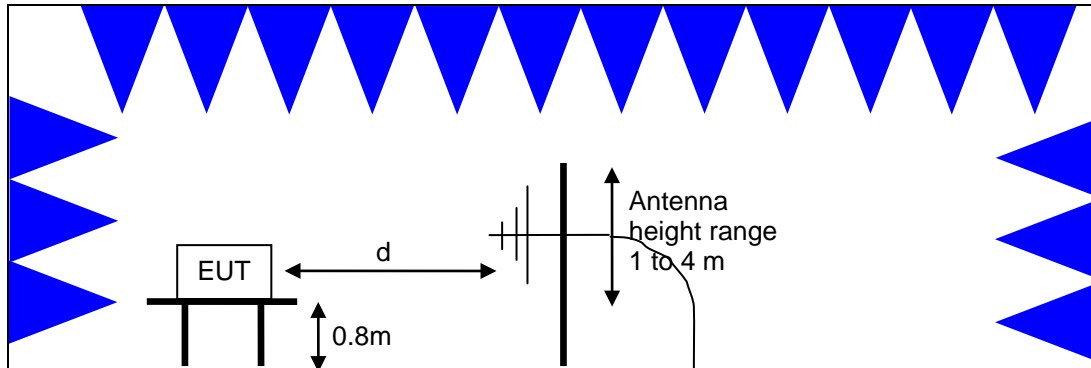

Test Configuration for Radiated Field Strength Measurements
Semi-Anechoic Chamber, Plan and Side Views

CONDUCTED EMISSIONS FROM ANTENNA PORT

Direct measurements of power, bandwidth and power spectral density are performed, where possible, with the antenna port of the EUT connected to either the power meter or spectrum analyzer via a suitable attenuator and/or filter. These are used to ensure that the front end of the measurement instrument is not overloaded by the fundamental transmission.

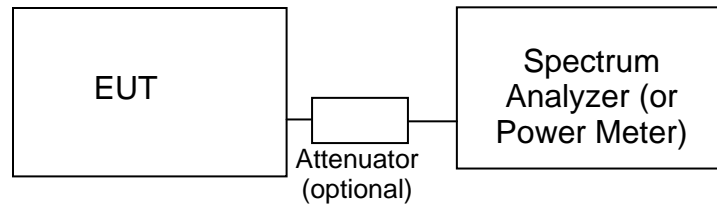

Test Configuration for Antenna Port Measurements

Measurement bandwidths (video and resolution) are set in accordance with the relevant standards and NTS Silicon Valley's test procedures for the type of radio being tested. When power measurements are made using a resolution bandwidth less than the signal bandwidth the power is calculated by summing the power across the signal bandwidth using either the analyzer channel power function or by capturing the trace data and calculating the power using software. In both cases the summed power is corrected to account for the equivalent noise bandwidth (ENBW) of the resolution bandwidth used.

If power averaging is used (typically for certain digital modulation techniques), the EUT is configured to transmit continuously. Power averaging is performed using either the built-in function of the analyzer or, if the analyzer does not feature power averaging, using external software. In both cases the average power is calculated over a number of sweeps (typically 100). When the EUT cannot be configured to continuously transmit then either the analyzer is configured to perform a gated sweep to ensure that the power is averaged over periods that the device is transmitting or power averaging is disabled and a max-hold feature is used.

If a power meter is used to make output power measurements the sensor head type (peak or average) is stated in the test data table.

BANDWIDTH MEASUREMENTS

The 6dB, 20dB, 26dB and/or 99% signal bandwidth are measured using the bandwidths recommended by ANSI C63.10 and RSS GEN.

SPECIFICATION LIMITS AND SAMPLE CALCULATIONS

The limits for conducted emissions are given in units of microvolts, and the limits for radiated emissions are given in units of microvolts per meter at a specified test distance. Data is measured in the logarithmic form of decibels relative to one microvolt, or dB microvolts (dBuV). For radiated emissions, the measured data is converted to the field strength at the antenna in dB microvolts per meter (dBuV/m). The results are then converted to the linear forms of uV and uV/m for comparison to published specifications.

For reference, converting the specification limits from linear to decibel form is accomplished by taking the base ten logarithm, then multiplying by 20. These limits in both linear and logarithmic form are as follows:

CONDUCTED EMISSIONS SPECIFICATION LIMITS: FCC 15.207; FCC 15.107(a), RSS GEN

The table below shows the limits for the emissions on the AC power line from an intentional radiator and a receiver.

Frequency (MHz)	Average Limit (dBuV)	Quasi Peak Limit (dBuV)
0.150 to 0.500	Linear decrease on logarithmic frequency axis between 56.0 and 46.0	Linear decrease on logarithmic frequency axis between 66.0 and 56.0
0.500 to 5.000	46.0	56.0
5.000 to 30.000	50.0	60.0

GENERAL TRANSMITTER RADIATED EMISSIONS SPECIFICATION LIMITS

The table below shows the limits for the spurious emissions from transmitters that fall in restricted bands¹ (with the exception of transmitters operating under FCC Part 15 Subpart D and RSS 210 Annex 9), the limits for all emissions from a low power device operating under the general rules of RSS 310 (tables 3 and 4), RSS 210 (table 2) and FCC Part 15 Subpart C section 15.209.

Frequency Range (MHz)	Limit (uV/m)	Limit (dBuV/m @ 3m)
0.009-0.490	$2400/F_{\text{KHz}} @ 300\text{m}$	$67.6-20*\log_{10}(F_{\text{KHz}}) @ 300\text{m}$
0.490-1.705	$24000/F_{\text{KHz}} @ 30\text{m}$	$87.6-20*\log_{10}(F_{\text{KHz}}) @ 30\text{m}$
1.705 to 30	30 @ 30m	29.5 @ 30m
30 to 88	100 @ 3m	40 @ 3m
88 to 216	150 @ 3m	43.5 @ 3m
216 to 960	200 @ 3m	46.0 @ 3m
Above 960	500 @ 3m	54.0 @ 3m

FCC 15.407 (a) OUTPUT POWER LIMITS

The table below shows the limits for output power and output power density. Where the signal bandwidth is less than 20 MHz the maximum output power is reduced to the power spectral density limit plus 10 times the log of the bandwidth (in MHz).

Operating Frequency (MHz)	Output Power	Power Spectral Density
5150 – 5250	50mW (17 dBm)	4 dBm/MHz
5250 – 5350	250 mW (24 dBm)	11 dBm/MHz
5725 – 5825	1 Watts (30 dBm)	17 dBm/MHz

For system using antennas with gains exceeding 6dBi, the output power and power spectral density limits are reduced by 1dB for every dB the antenna gain exceeds 6dBi. Fixed point-to-point applications using the 5725 – 5825 MHz band may use antennas with gains of up to 23dBi without this limitation. If the gain exceeds 23dBi then the output power limit of 1 Watt is reduced by 1dB for every dB the gain exceeds 23dBi.

The peak excursion envelope is limited to 13dB.

SPURIOUS EMISSIONS LIMITS –UNII and LELAN DEVICES

The spurious emissions limits for signals below 1GHz are the FCC/RSS-GEN general limits. For emissions above 1GHz, signals in restricted bands are subject to the FCC/RSS GEN general limits. All other signals have a limit of –27dBm/MHz, which is a field strength of 68.3dBuV/m/MHz at a distance of 3m. For devices operating in the 5725-5850Mhz bands under the LELAN/UNII rules, the limit within 10MHz of the allocated band is increased to –17dBm/MHz.

¹ The restricted bands are detailed in FCC 15.203, RSS 210 Table 1 and RSS 310 Table 2

SAMPLE CALCULATIONS - CONDUCTED EMISSIONS

Receiver readings are compared directly to the conducted emissions specification limit (decibel form) as follows:

$$R_r - S = M$$

where:

R_r = Receiver Reading in dBuV

S = Specification Limit in dBuV

M = Margin to Specification in +/- dB

SAMPLE CALCULATIONS - RADIATED EMISSIONS

Receiver readings are compared directly to the specification limit (decibel form). The receiver internally corrects for cable loss, preamplifier gain, and antenna factor. The calculations are in the reverse direction of the actual signal flow, thus cable loss is added and the amplifier gain is subtracted. The Antenna Factor converts the voltage at the antenna coaxial connector to the field strength at the antenna elements.

A distance factor, when used for electric field measurements above 30MHz, is calculated by using the following formula:

$$F_d = 20 * \text{LOG}_{10} (D_m/D_s)$$

where:

F_d = Distance Factor in dB

D_m = Measurement Distance in meters

D_s = Specification Distance in meters

For electric field measurements below 30MHz the extrapolation factor is either determined by making measurements at multiple distances or a theoretical value is calculated using the formula:

$$F_d = 40 * \text{LOG}_{10} (D_m/D_s)$$

Measurement Distance is the distance at which the measurements were taken and Specification Distance is the distance at which the specification limits are based. The antenna factor converts the voltage at the antenna coaxial connector to the field strength at the antenna elements.

The margin of a given emission peak relative to the limit is calculated as follows:

$$R_c = R_r + F_d$$

and

$$M = R_c - L_s$$

where:

R_r = Receiver Reading in dBuV/m

F_d = Distance Factor in dB

R_c = Corrected Reading in dBuV/m

L_s = Specification Limit in dBuV/m

M = Margin in dB Relative to Spec

SAMPLE CALCULATIONS - FIELD STRENGTH TO EIRP CONVERSION

Where the radiated electric field strength is expressed in terms of the equivalent isotropic radiated power (eirp), or where a field strength measurement of output power is made in lieu of a direct measurement, the following formula is used to convert between eirp and field strength at a distance of d (meters) from the equipment under test:

$$E = \frac{1000000 \sqrt{30 P}}{d} \quad \text{microvolts per meter}$$

where P is the eirp (Watts)

For a measurement at 3m the conversion from a logarithmic value for field strength (dBuV/m) to an eirp power (dBm) is -95.3dB.

Appendix A Test Equipment Calibration Data

<u>Manufacturer</u>	<u>Description</u>	<u>Model</u>	<u>Asset #</u>	<u>Calibrated</u>	<u>Cal Due</u>
Radiated Emissions, 30 - 2,000 MHz, 03-Sep-14					
EMCO	Antenna, Horn, 1-18 GHz (SA40-Red)	3115	1142		9/23/2014
Sunol Sciences	Biconilog, 30-3000 MHz	JB3	1548		9/9/2014
Rohde & Schwarz	EMI Test Receiver, 20 Hz-7 GHz	ESIB7	1630		6/21/2015
Micro-Tronics	Band Reject Filter, 5725-5875 MHz	BRC50705-02	1682		7/15/2015
Hewlett Packard	Microwave Preamplifier, 1- 26.5GHz	8449B	2199		2/20/2015
Hewlett Packard	SpecAn 9 kHz - 40 GHz, (SA40) Purple	8564E (84125C)	2415		2/27/2015
Com-Power	Preamplifier, 1-1000 MHz	PAM-103	2885		11/1/2014
Conducted Emissions - AC Power Ports, 03-Sep-14					
Rohde & Schwarz	Pulse Limiter	ESH3 Z2	1401		5/15/2015
Rohde & Schwarz	EMI Test Receiver, 20 Hz-7 GHz	ESIB7	1630		6/21/2015
Fischer Custom Comm	LISN, 25A, 150kHz to 30MHz, 25 Amp,	FCC-LISN-50- 25-2-09	2000		4/4/2015
Radiated Emissions, 1,000 - 6,500 MHz, 27-Oct-14					
EMCO	Antenna, Horn, 1-18 GHz	3115	487	7/29/2014	7/29/2016
Rohde & Schwarz	EMI Test Receiver, 20 Hz-7 GHz	ESIB7	1630	6/21/2014	6/21/2015
Radiated Emissions BE, 1000 - 6,500 MHz, 27-Oct-14					
EMCO	Antenna, Horn, 1-18 GHz	3115	487	7/29/2014	7/29/2016
Rohde & Schwarz	EMI Test Receiver, 20 Hz-7 GHz	ESIB7	1630	6/21/2014	6/21/2015
Radiated Emissions, 1,000 - 18,000 MHz, 28-Oct-14 to 29-Oct-14					
EMCO	Antenna, Horn, 1-18 GHz	3115	487	7/29/2014	7/29/2016
Hewlett Packard	High Pass filter, 8.2 GHz (Purple System)	P/N 84300- 80039	1767	11/26/2013	11/26/2014
Hewlett Packard	Microwave Preamplifier, 1- 26.5GHz	8449B	2199	2/20/2014	2/20/2015
Micro-Tronics	Band Reject Filter, 5150-5350 MHz	BRC50703-02	2239	9/16/2014	9/16/2015
Micro-Tronics	Band Reject Filter, 5470-5725 MHz	BRC50704-02	2240	9/16/2014	9/16/2015
Micro-Tronics	Band Reject Filter, 5725-5875 MHz	BRC50705-02	2241	9/16/2014	9/16/2015
Hewlett Packard	SpecAn 9 kHz - 40 GHz, (SA40) Purple	8564E (84125C)	2415	2/27/2014	2/27/2015
Radiated Emissions, 1000 - 40,000 MHz, 30-Oct-14 to 31-Oct-14					
Hewlett Packard	Head (Inc W1-W4, 1946 , 1947) Purple	84125C	1772	4/25/2014	4/25/2015
A. H. Systems	Purple System Horn, 18- 40GHz	SAS-574, p/n: 2581	2160	8/11/2014	8/11/2015
EMCO	Antenna, Horn, 1-18 GHz	3115	487	7/29/2014	7/29/2016
Hewlett Packard	High Pass filter, 8.2 GHz (Purple System)	P/N 84300- 80039	1767	11/26/2013	11/26/2014

<u>Manufacturer</u>	<u>Description</u>	<u>Model</u>	<u>Asset #</u>	<u>Calibrated</u>	<u>Cal Due</u>
Hewlett Packard	Microwave Preamplifier, 1-26.5GHz	8449B	2199	2/20/2014	2/20/2015
Micro-Tronics	Band Reject Filter, 5150-5350 MHz	BRC50703-02	2239	9/16/2014	9/16/2015
Micro-Tronics	Band Reject Filter, 5470-5725 MHz	BRC50704-02	2240	9/16/2014	9/16/2015
Micro-Tronics	Band Reject Filter, 5725-5875 MHz	BRC50705-02	2241	9/16/2014	9/16/2015
Hewlett Packard	SpecAn 9 kHz - 40 GHz, (SA40) Purple	8564E (84125C)	2415	2/27/2014	2/27/2015
Radio Antenna Port (Power and Spurious Emissions), 31-Oct-14 to 04-Nov-14					
Agilent Technologies	3Hz -44GHz PSA Spectrum Analyzer	E4446A	2796	2/6/2014	2/6/2015
Radiated Emissions, 1000 - 40,000 MHz, 06-Nov-14					
EMCO	Antenna, Horn, 1-18 GHz	3115	487	7/29/2014	7/29/2016
Hewlett Packard	High Pass filter, 8.2 GHz (Purple System)	P/N 84300-80039	1767	11/26/2013	11/26/2014
Hewlett Packard	Head (Inc W1-W4, 1946 , 1947) Purple	84125C	1772	4/25/2014	4/25/2015
A. H. Systems	Purple System Horn, 18-40GHz	SAS-574, p/n: 2581	2160	8/11/2014	8/11/2015
Hewlett Packard	Microwave Preamplifier, 1-26.5GHz	8449B	2199	2/20/2014	2/20/2015
Micro-Tronics	Band Reject Filter, 5470-5725 MHz	BRC50704-02	2240	9/16/2014	9/16/2015
Hewlett Packard	SpecAn 9 kHz - 40 GHz, (SA40) Purple	8564E (84125C)	2415	2/27/2014	2/27/2015
Radiated Emissions, 1,000 - 11,000 MHz, 10-Dec-14					
Hewlett Packard	Microwave Preamplifier, 1-26.5GHz	8449B	263	3/25/2014	3/25/2015
EMCO	Antenna, Horn, 1-18 GHz	3115	487	7/29/2014	7/29/2016
Hewlett Packard	SpecAn 30 Hz -40 GHz, SV (SA40) Red	8564E (84125C)	1148	9/20/2014	9/20/2015
Rohde & Schwarz	EMI Test Receiver, 20 Hz-7 GHz	ESIB7	1630	6/21/2014	6/21/2015
Micro-Tronics	Band Reject Filter, 5150-5350 MHz	BRC50703-02	2239	9/16/2014	9/16/2015
Micro-Tronics	Band Reject Filter, 5470-5725 MHz	BRC50704-02	2240	9/16/2014	9/16/2015
Radiated Emissions, 1,000 - 12,000 MHz, 12-Dec-14					
Hewlett Packard	Microwave Preamplifier, 1-26.5GHz	8449B	263	3/25/2014	3/25/2015
EMCO	Antenna, Horn, 1-18 GHz	3115	487	7/29/2014	7/29/2016
Hewlett Packard	SpecAn 30 Hz -40 GHz, SV (SA40) Red	8564E (84125C)	1148	9/20/2014	9/20/2015
Micro-Tronics	Band Reject Filter, 5470-5725 MHz	BRC50704-02	2240	9/16/2014	9/16/2015
Radiated Emissions, 11 - 40,000 MHz, 15-Dec-14					
Hewlett Packard	Microwave Preamplifier, 1-26.5GHz	8449B	263	3/25/2014	3/25/2015
EMCO	Antenna, Horn, 1-18 GHz	3115	487	7/29/2014	7/29/2016



<u>Manufacturer</u>	<u>Description</u>	<u>Model</u>	<u>Asset #</u>	<u>Calibrated</u>	<u>Cal Due</u>
Hewlett Packard	SpecAn 30 Hz -40 GHz, SV (SA40) Red	8564E (84125C)	1148	9/20/2014	9/20/2015
Hewlett Packard	High Pass filter, 8.2 GHz	P/N 84300-80039	1156	6/7/2014	6/7/2015
Micro-Tronics	Band Reject Filter, 5725-5875 MHz	BRC50705-02	1682	7/15/2014	7/15/2015
A. H. Systems	Red System Horn, 18-40GHz	SAS-574, p/n: 2581	2161	7/9/2014	7/9/2015
Radio Antenna Port (Power and Spurious Emissions), 16-Dec-14					
Agilent Technologies	PSA, Spectrum Analyzer, (installed options, 111, 115, 123, 1DS, B7J, HYX,	E4446A	2139	4/8/2014	4/8/2015

Appendix B Test Data

T96173 Pages 28 – 161



EMC Test Data

Client:	Vivint Wireless	Job Number:	J96091
Product	1520 (4x4 5GHz 802.11 Client)	T-Log Number:	T96173
		Project Manager:	Irene Rademacher
Contact:	Venkat Kalkunte	Project Coordinator:	-
Emissions Standard(s):	FCC 15.B / 15.407 (New Rules)	Class:	B
Immunity Standard(s):	-	Environment:	-

EMC Test Data

For The

Vivint Wireless

Product

1520 (4x4 5GHz 802.11 Client)

Date of Last Test: 12/16/2014



EMC Test Data

Client: Vivint Wireless	Job Number: J96091
Model: 1520 (4x4 5GHz 802.11 Client)	T-Log Number: T96173
	Project Manager: Irene Rademacher
Contact: Venkat Kalkunte	Project Coordinator: -
Standard: FCC 15.B / 15.407 (New Rules)	Class: N/A

Power vs. Data Rate

In normal operating modes the card uses power settings stored on EEPROM to set the output power. For a given nominal output power the actual transmit power normally is reduced as the data rate increases, therefore testing was performed at the data rate in the mode with highest power to determine compliance with the requirements.

The following power measurements were made using a GATED average power meter and with the device configured in a continuous transmit mode on Chain 1 at the various data rates in each mode to verify the highest power mode:

Sample Notes

Sample S/N: prototype

Driver: -

Date of Test: 10/16/2014

Test Location: Lab 4

Test Engineer: Mehra n Birgani

Mode	Data Rate	Power (dBm)	Power setting
802.11n 20MHz	6.5	13.8	17.0
	13	13.8	
	19.5	13.7	
	26	13.6	
	39	13.6	
	52	13.6	
	58.5	13.5	
	65	13.5	
	78	13.3	<<-11ac mode only
802.11n/ac 40MHz	13.5	14.6	17.0
	27	14.4	
	40.5	14.4	
	54	14.3	
	81	13.9	
	108	13.7	
	121.5	13.6	
	135	13.4	
	162	13.3	
	180	13.2	

Note : Power setting - the software power setting used during testing, included for reference only.

Client: Vivint Wireless	Job Number: J96091
Model: 1520 (4x4 5GHz 802.11 Client)	T-Log Number: T96173
	Project Manager: Irene Rademacher
Contact: Venkat Kalkunte	Project Coordinator: -
Standard: FCC 15.B / 15.407 (New Rules)	Class: N/A

Duty Cycle

Duty cycle measurements performed on the worse case data rate for power.

Notes: Measurements taken with maximum RBW/VBW settings allowed.

Mode	Data Rate	Duty Cycle (x)	Constant DC?	T (ms)	Pwr Cor Factor*	Lin Volt Cor Factor**	Min VBW for FS (Hz)
n20	6.5	96.5%	yes	2.54	0.16	0.31	394
n40	13.5	94.3%	yes	1.27	0.26	0.51	787
ac80	MCS8	92.1%	yes	0.58	0.36	0.72	1724

* Correction factor when using RMS/Power averaging - $10 \cdot \log(1/x)$

** Correction factor when using linear voltage average - $20 \cdot \log(1/x)$

T = Minimum transmission duration

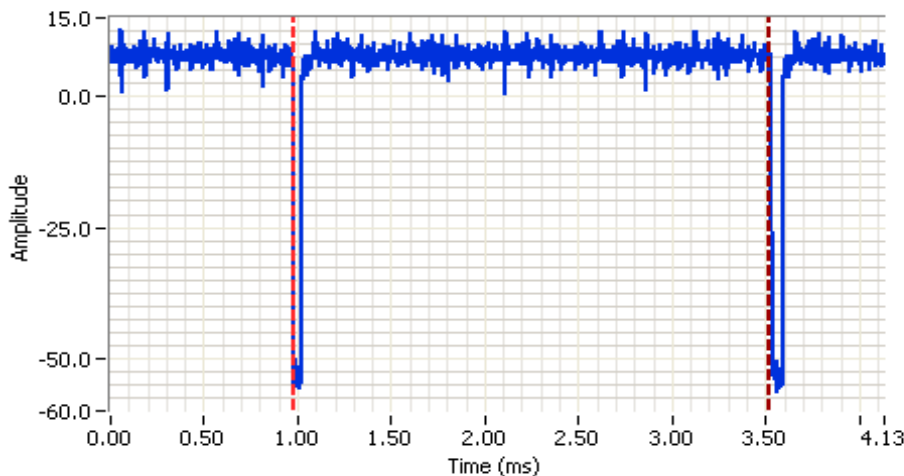

Analyzer Settings

Agilent Technologies, E4446A
 CF: 5500.000 MHz
 SPAN: 0.000 MHz
 RB: 2.000 MHz
 VB: 1.000 MHz
 Detector: POS
 Attn: 20 DB
 RL Offset: 11.5 DB
 Sweep Time: 4.1ms
 Ref Lvl: 20.0 DBM

Comments

802.11n 20MHz MCS8
 On time: 2.45ms
 Cycle time: 2.54ms
 Duty cycle: 96.5%

Cursor 1	0.9790	20.00	
Cursor 2	3.5180	20.00	

Delta Time (ms) 2.539

Delta Amplitude 0.00

Client: Vivint Wireless	Job Number: J96091
Model: 1520 (4x4 5GHz 802.11 Client)	T-Log Number: T96173
Contact: Venkat Kalkunte	Project Manager: Irene Rademacher
Standard: FCC 15.B / 15.407 (New Rules)	Project Coordinator: -
	Class: N/A

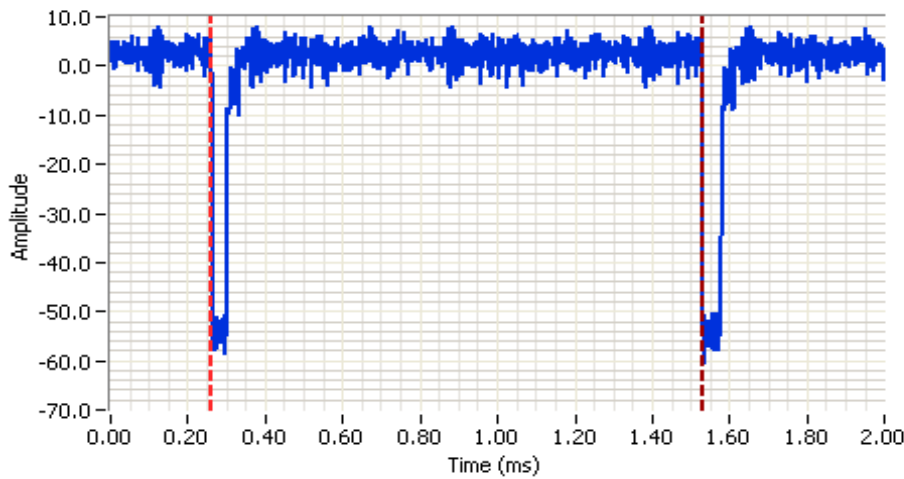

Analyzer Settings
 Agilent Technologies, E4446A
 CF: 5510.000 MHz
 SPAN: 0.000 MHz
 RB: 2.000 MHz
 VB: 1.000 MHz
 Detector: POS
 Attn: 20 DB
 RL Offset: 11.5 DB
 Sweep Time: 2.0ms
 Ref Lvl: 20.0 DBM

Comments
 802.11n 40MHz MCS8
 On time: 1.20
 Cycle time: 1.27ms
 Duty cycle: 94.3%

Cursor 1 0.2603 12.00    Delta Time (ms) 1.270
 Cursor 2 1.5305 12.00    Delta Amplitude 0.00

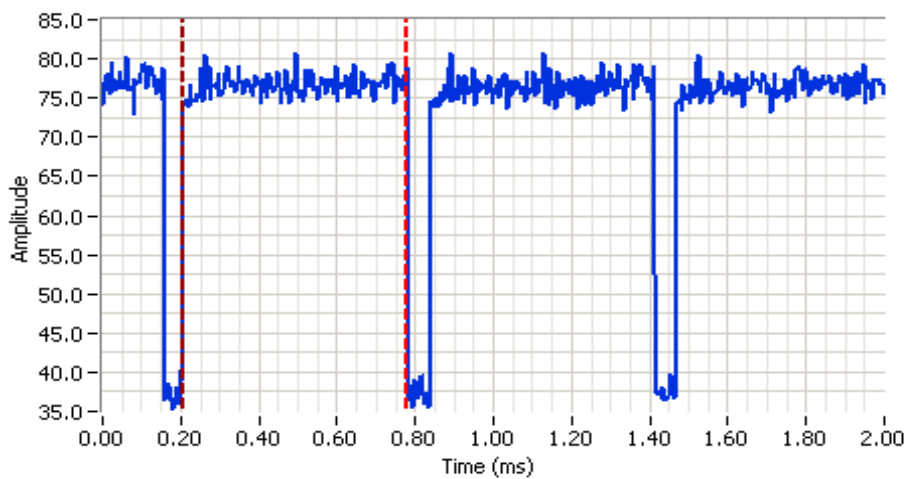

Analyzer Settings
 Rohde&Schwarz, ESI
 CF: 5210.000 MHz
 SPAN: 0.000 MHz
 RB: 5.000 MHz
 VB: 5.000 MHz
 Detector: POS
 Attn: 10 DB
 RL Offset: 0.0 DB
 Sweep Time: 2.0ms
 Ref Lvl: 83.5 DBUv

Comments
 802.11ac MCS8
 On time: 0.58ms
 Off time: 0.05ms
 Duty cycle: 92.1 %

Cursor 1 0.7794 100.00    Delta Time (ms) 0.58
 Cursor 2 0.2041 100.00    Delta Amplitude 0.00





EMC Test Data

Client: Vivint Wireless	Job Number: J96091
Model: 1520 (4x4 5GHz 802.11 Client)	T-Log Number: T96173
	Project Manager: Irene Rademacher
Contact: Venkat Kalkunte	Project Coordinator: -
Standard: FCC 15.B / 15.407 (New Rules)	Class: N/A

RSS 210 and FCC 15.407 (UNII) Radiated Spurious Emissions

Test Specific Details

Objective: The objective of this test session is to perform final qualification testing of the EUT with respect to the specification listed above.

General Test Configuration

The EUT and all local support equipment were located on the turntable for radiated spurious emissions testing. For radiated emissions testing the measurement antenna was located 3 meters from the EUT, unless otherwise noted.

Ambient Conditions:

Temperature: 23 °C
Rel. Humidity: 40 %

Summary of Results

Run #	Mode	Channel	Target Power Setting	Passing Power Setting	Test Performed	Limit	Result / Margin
1	n20	36 - 5180MHz	21	18	Restricted Band Edge at 5150 MHz	15.209	52.5 dBµV/m @ 5150.0 MHz (-1.5dB)
	n20	40 - 5200MHz	21	21	Restricted Band Edge at 5150 MHz	15.209	50.2 dBµV/m @ 5150.0 MHz (-3.8 dB)
2	n20	64 - 5320MHz	21	19	Restricted Band Edge at 5350 MHz	15.209	53.3 dBµV/m @ 5350.0 MHz (-0.7 dB)
3	n20	100 - 5500MHz	21	19	Restricted Band Edge at 5460 MHz	15.209	53.5 dBµV/m @ 5460.0 MHz (-0.5 dB)
					Band Edge 5460 - 5470 MHz	15E	53.6 dBµV/m @ 5470.0 MHz (-0.4 dB)
	n20	140 - 5700MHz	21	18	Band Edge 5725MHz	15E	53.8 dBµV/m @ 5725.0 MHz (-0.2 dB)
4	n20	149 - 5745MHz	21	19	Band Edge 5725MHz	15E	77.0 dBµV/m @ 5724.8 MHz (-1.3 dB)
	n20				Band Edge 5715MHz	15E	63.6 dBµV/m @ 5714.8 MHz (-4.7 dB)
	n20	165 - 5825MHz	21	21	Band Edge 5850MHz	15E	76.2 dBµV/m @ 5850.4 MHz (-2.1 dB)
	n20				Band Edge 5860MHz	15E	66.2 dBµV/m @ 5863.0 MHz (-2.1 dB)

Client:	Vivint Wireless	Job Number:	J96091
Model:	1520 (4x4 5GHz 802.11 Client)	T-Log Number:	T96173
		Project Manager:	Irene Rademacher
Contact:	Venkat Kalkunte	Project Coordinator:	-
Standard:	FCC 15.B / 15.407 (New Rules)	Class:	N/A

Modifications Made During Testing

No modifications were made to the EUT during testing

Deviations From The Standard

No deviations were made from the requirements of the standard.

Procedure Comments:

Measurements performed in accordance with FCC KDB 789033

Peak measurements performed with: RBW=1MHz, VBW=3MHz, peak detector, max hold, auto sweep time

Unless otherwise stated/noted, emission has duty cycle $\geq 98\%$ and was measured using RBW=1MHz, VBW=10Hz, peak detector, linear average mode, auto sweep time, max hold.

Mode	Data Rate	Duty Cycle (x)	Constant DC?	T (ms)	Pwr Cor Factor*	Lin Volt Cor Factor**	Min VBW for FS (Hz)
n20	6.5	96.5%	yes	2.54	0.16	0.31	394

Sample Notes

Sample S/N: Prototype

Driver: -

Antenna: 6dBi

Measurement Specific Notes:

Note 1:	For emissions outside of the restricted bands the limit is -27dBm/MHz eirp (68.3dBuV/m). The measurement method required is a peak measurement (RB=1MHz, VB \geq 3MHz, peak detector). Per KDB 789033 2) c) (i), compliance can be demonstrated by meeting the average and peak limits of 15.209, as an alternative.
Note 2:	Emission has duty cycle $\geq 98\%$, average measurement performed: RBW=1MHz, VBW=3MHz, RMS, Power averaging, auto sweep, trace average 100 traces
Note 3:	Emission has duty cycle $< 98\%$, but constant, average measurement performed: RBW=1MHz, VBW=10Hz, peak detector, linear averaging, auto sweep, trace average $100 * 1/DC$ traces, measurement corrected by Linear Voltage correction factor
Note 4:	Emission has duty cycle $< 98\%$ and is NOT constant, average measurement performed: RBW=1MHz, VBW $> 1/T$, peak detector, linear average mode, sweep time auto, max hold. Max hold for $50*(1/DC)$ traces
Note 5:	Emission has duty cycle $< 98\%$, but constant, average measurement performed: RBW=1MHz, VBW=3MHz, RMS, Power averaging, auto sweep, trace average $100 * 1/DC$ traces, measurement corrected by Pwr correction factor
Note 6:	Plots of the average and peak bandedge do not account for any duty cycle correction. Refer to the tabluar results for final measurements.



EMC Test Data

Client: Vivint Wireless	Job Number: J96091
Model: 1520 (4x4 5GHz 802.11 Client)	T-Log Number: T96173
	Project Manager: Irene Rademacher
Contact: Venkat Kalkunte	Project Coordinator: -
Standard: FCC 15.B / 15.407 (New Rules)	Class: N/A

Run #1: Radiated Bandedge Measurements, 5150-5250MHz

Date of Test: 10/27/2014 0:00
 Test Engineer: Mark Hill / Jack Liu
 Test Location: FT Chamber #4

Config. Used: 1
 Config Change: -
 EUT Voltage: POE

Channel: 36 - 5180 MHz Power Setting: 18
 Tx Chain: 4Tx
 Mode: n20
 Data Rate: MSC8

5150 MHz Band Edge Signal Radiated Field Strength

Frequency MHz	Level dB μ V/m	Pol v/h	FCC 15.209		Detector Pk/QP/Avg	Azimuth degrees	Height meters	Comments
			Limit	Margin				
5150.000	52.5	V	54.0	-1.5	AVG	258	1.5	Note 3, pwr = 18
5149.680	66.0	V	74.0	-8.0	PK	258	1.5	
5149.920	48.3	H	54.0	-5.7	AVG	261	1.8	Note 3, pwr = 18
5148.160	60.2	H	74.0	-13.8	PK	261	1.8	

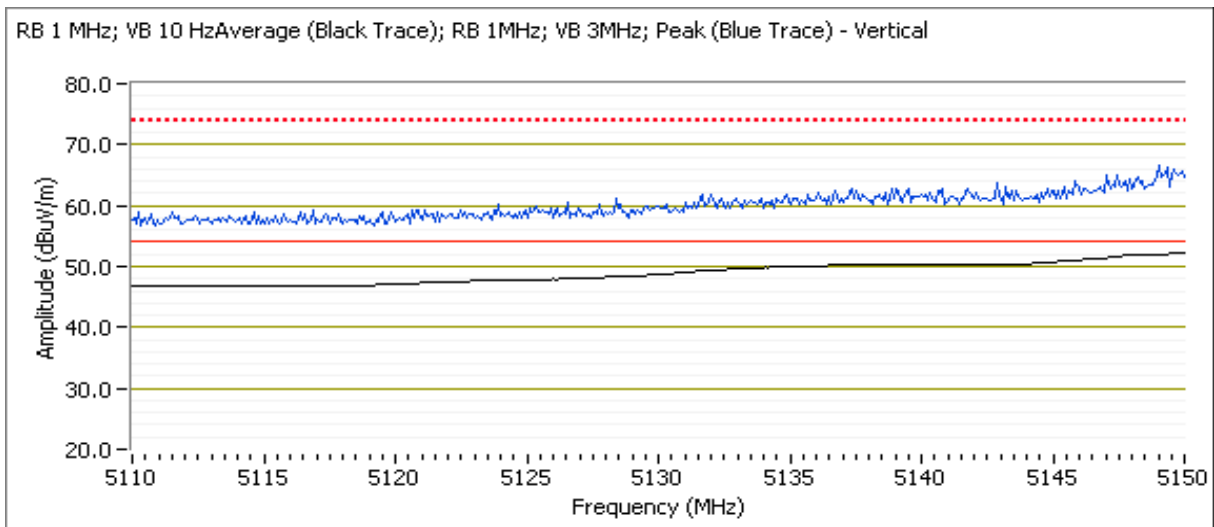

Client: Vivint Wireless	Job Number: J96091
Model: 1520 (4x4 5GHz 802.11 Client)	T-Log Number: T96173
	Project Manager: Irene Rademacher
Contact: Venkat Kalkunte	Project Coordinator: -
Standard: FCC 15.B / 15.407 (New Rules)	Class: N/A

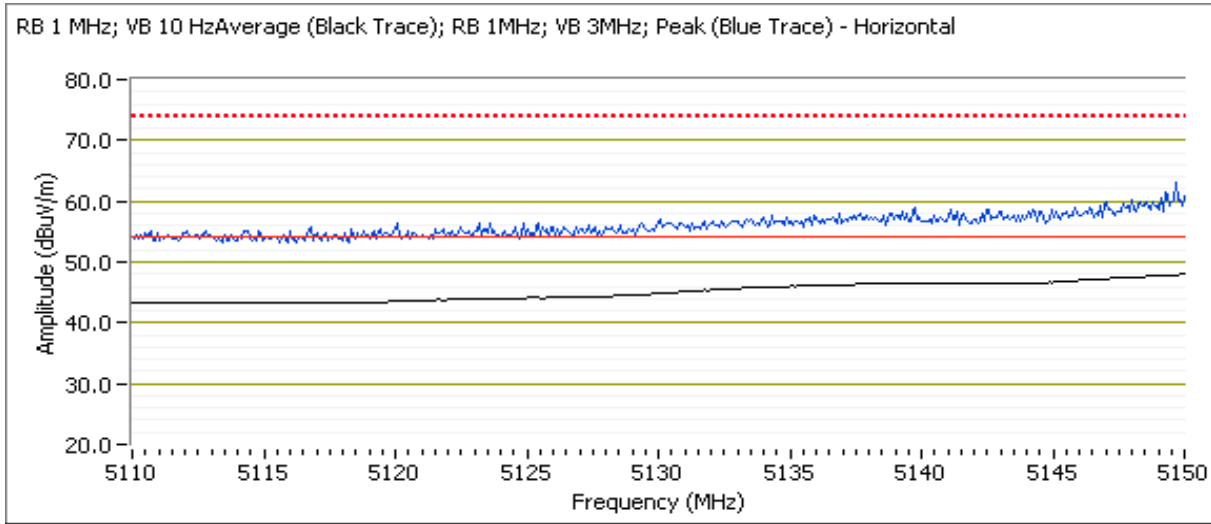



EMC Test Data

Client: Vivint Wireless	Job Number: J96091
Model: 1520 (4x4 5GHz 802.11 Client)	T-Log Number: T96173
	Project Manager: Irene Rademacher
Contact: Venkat Kalkunte	Project Coordinator: -
Standard: FCC 15.B / 15.407 (New Rules)	Class: N/A

Channel: 40 - 5200 MHz Power Setting: 21
 Tx Chain: 4Tx
 Mode: n20
 Data Rate: MSC8

5150 MHz Band Edge Signal Radiated Field Strength

Frequency MHz	Level dB μ V/m	Pol v/h	FCC 15.209		Detector Pk/QP/Avg	Azimuth degrees	Height meters	Comments
			Limit	Margin				
5150.000	50.2	V	54.0	-3.8	AVG	256	1.8	POS; RB 1 MHz; VB: 10 Hz; Note 3
5147.440	62.8	V	74.0	-11.2	PK	256	1.8	POS; RB 1 MHz; VB: 3 MHz
5149.920	45.7	H	54.0	-8.3	AVG	254	1.7	POS; RB 1 MHz; VB: 10 Hz; Note 3
5148.720	57.1	H	74.0	-16.9	PK	254	1.7	POS; RB 1 MHz; VB: 3 MHz

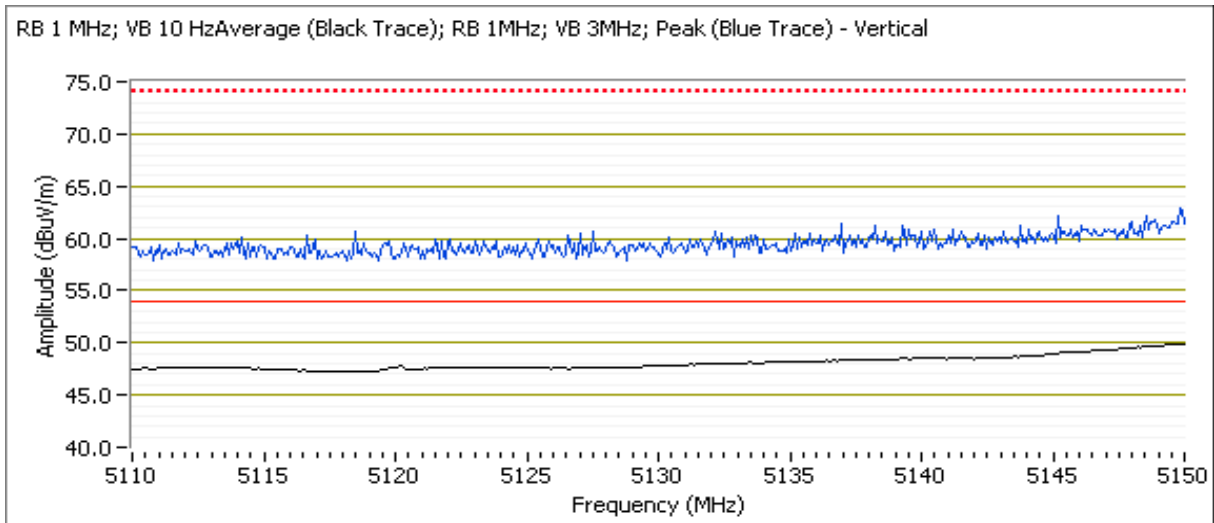



EMC Test Data

Client: Vivint Wireless	Job Number: J96091
Model: 1520 (4x4 5GHz 802.11 Client)	T-Log Number: T96173
	Project Manager: Irene Rademacher
Contact: Venkat Kalkunte	Project Coordinator: -
Standard: FCC 15.B / 15.407 (New Rules)	Class: N/A

Run #2: Radiated Bandedge Measurements, 5250-5350MHz

Date of Test: 10/27/2014 0:00
 Test Engineer: Jack Liu
 Test Location: FT Chamber #4

Config. Used: 1
 Config Change: -
 EUT Voltage: POE

Channel: 64 - 5320MHz Power Setting: 19
 Tx Chain: 4Tx
 Mode: n20
 Data Rate: MSC8

5350 MHz Band Edge Signal Radiated Field Strength

Frequency	Level	Pol	FCC 15.209		Detector	Azimuth	Height	Comments
MHz	dB μ V/m	v/h	Limit	Margin	Pk/QP/Avg	degrees	meters	
Power setting :19								
5350.000	53.3	V	54.0	-0.7	AVG	265	2.0	POS; RB 1 MHz; VB: 10 Hz; Note 3
5353.850	68.2	V	74.0	-5.8	PK	265	2.0	POS; RB 1 MHz; VB: 3 MHz
5350.000	49.8	H	54.0	-4.2	AVG	262	2.0	POS; RB 1 MHz; VB: 10 Hz; Note 3
5351.280	62.7	H	74.0	-11.3	PK	262	2.0	POS; RB 1 MHz; VB: 3 MHz

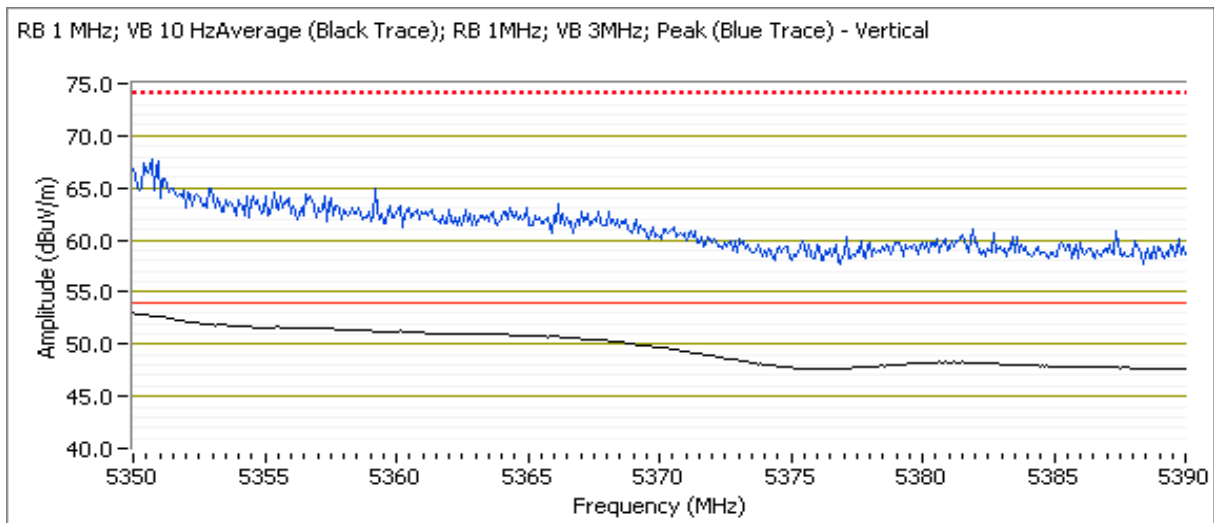



EMC Test Data

Client: Vivint Wireless	Job Number: J96091
Model: 1520 (4x4 5GHz 802.11 Client)	T-Log Number: T96173
	Project Manager: Irene Rademacher
Contact: Venkat Kalkunte	Project Coordinator: -
Standard: FCC 15.B / 15.407 (New Rules)	Class: N/A

Run #3: Radiated Bandedge Measurements, 5470-5725MHz

Date of Test: 10/27/2014 0:00
 Test Engineer: Jack Liu
 Test Location: FT Chamber #4

Config. Used: 1
 Config Change: -
 EUT Voltage: POE

Channel: 100 - 5500MHz Power Setting: 19
 Tx Chain: 4Tx
 Mode: n20
 Data Rate: MSC8

5460 MHz Band Edge Signal Radiated Field Strength

Frequency	Level	Pol	FCC 15.209		Detector	Azimuth	Height	Comments
MHz	dB μ V/m	v/h	Limit	Margin	Pk/QP/Avg	degrees	meters	
Power setting :19								
5460.000	53.5	V	54.0	-0.5	AVG	262	2.0	POS; RB 1 MHz; VB: 10 Hz; Note 3
5456.390	66.0	V	74.0	-8.0	PK	262	2.0	POS; RB 1 MHz; VB: 3 MHz
5460.000	48.9	H	54.0	-5.1	AVG	260	1.9	POS; RB 1 MHz; VB: 10 Hz; Note 3
5458.320	61.8	H	74.0	-12.2	PK	260	1.9	POS; RB 1 MHz; VB: 3 MHz

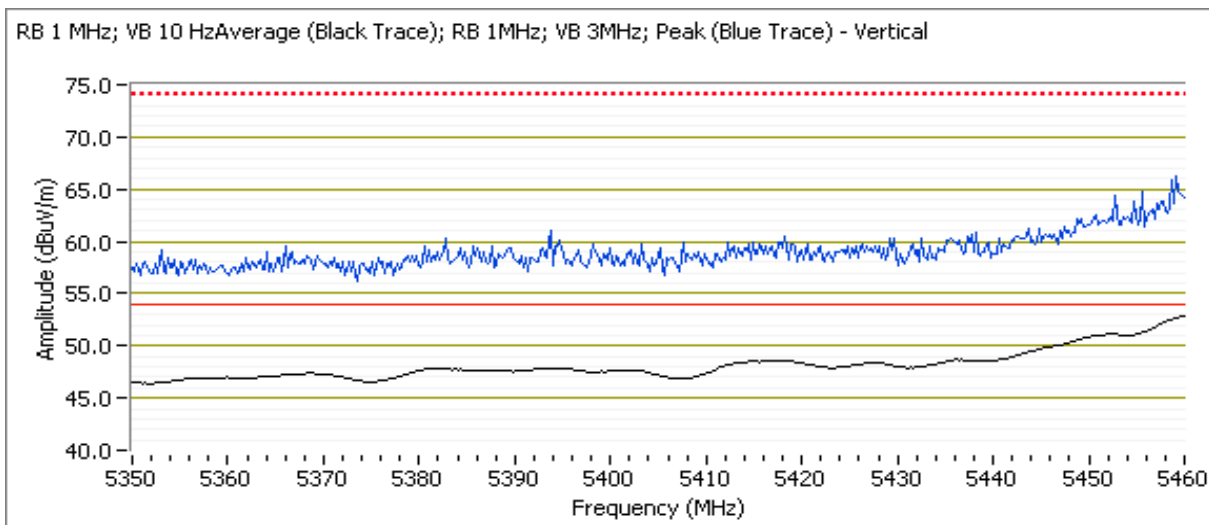



EMC Test Data

Client: Vivint Wireless	Job Number: J96091
Model: 1520 (4x4 5GHz 802.11 Client)	T-Log Number: T96173
	Project Manager: Irene Rademacher
Contact: Venkat Kalkunte	Project Coordinator: -
Standard: FCC 15.B / 15.407 (New Rules)	Class: N/A

5470 MHz Band Edge Signal Radiated Field Strength

Frequency MHz	Level dB μ V/m	Pol v/h	15.E		Detector Pk/QP/Avg	Azimuth degrees	Height meters	Comments
			Limit	Margin				
Power setting :19								
5470.000	53.6	V	54.0	-0.4	AVG	257	2.2	POS; RB 1 MHz; VB: 10 Hz; Note 3
5468.980	68.3	V	74.0	-5.7	PK	257	2.2	POS; RB 1 MHz; VB: 3 MHz
5470.000	48.7	H	54.0	-5.3	AVG	261	1.9	POS; RB 1 MHz; VB: 10 Hz; Note 3
5469.680	61.5	H	74.0	-12.5	PK	261	1.9	POS; RB 1 MHz; VB: 3 MHz

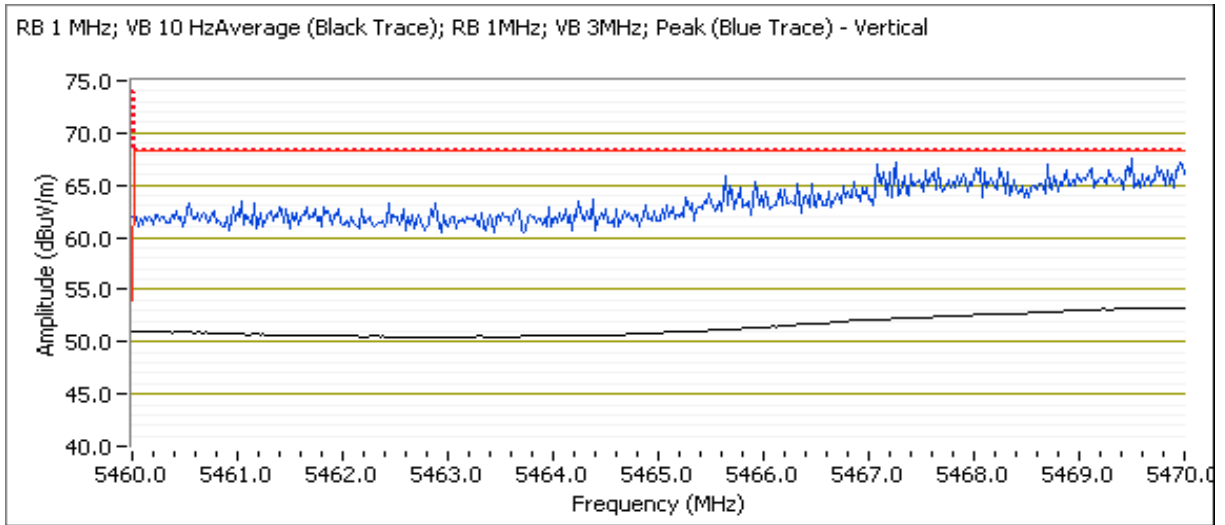



EMC Test Data

Client: Vivint Wireless	Job Number: J96091
Model: 1520 (4x4 5GHz 802.11 Client)	T-Log Number: T96173
	Project Manager: Irene Rademacher
Contact: Venkat Kalkunte	Project Coordinator: -
Standard: FCC 15.B / 15.407 (New Rules)	Class: N/A

Channel: 140- 5700MHz Power Setting: 18
 Tx Chain: 4Tx
 Mode: n20
 Data Rate: MSC8

5725 MHz Band Edge Signal Radiated Field Strength

Frequency MHz	Level dB μ V/m	Pol v/h	15.E		Detector Pk/QP/Avg	Azimuth degrees	Height meters	Comments
			Limit	Margin				
5725.000	53.8	V	54.0	-0.2	AVG	257	2.4	POS; RB 1 MHz; VB: 10 Hz; Note 3
5726.520	69.8	V	74.0	-4.2	PK	257	2.4	POS; RB 1 MHz; VB: 3 MHz
5725.000	49.4	H	54.0	-4.6	AVG	258	2.0	POS; RB 1 MHz; VB: 10 Hz; Note 3
5725.560	67.0	H	74.0	-7.0	PK	258	2.0	POS; RB 1 MHz; VB: 3 MHz

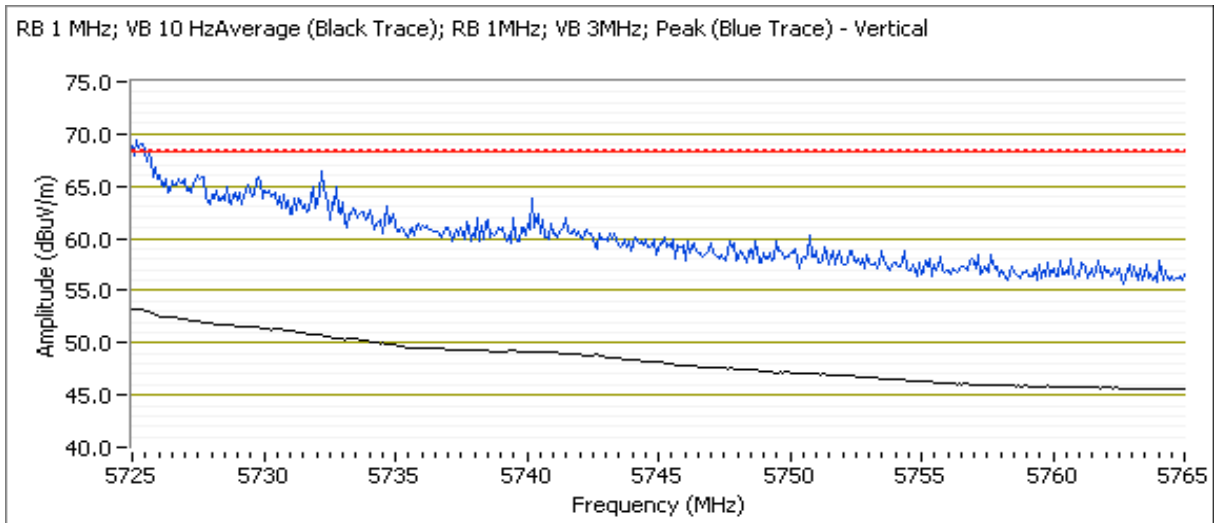



EMC Test Data

Client: Vivint Wireless	Job Number: J96091
Model: 1520 (4x4 5GHz 802.11 Client)	T-Log Number: T96173
	Project Manager: Irene Rademacher
Contact: Venkat Kalkunte	Project Coordinator: -
Standard: FCC 15.B / 15.407 (New Rules)	Class: N/A

Run #4: Radiated Bandedge Measurements, 5725-5850MHz

Date of Test: 10/27/2014 0:00
 Test Engineer: Jack Liu
 Test Location: FT Chamber #4

Config. Used: 1
 Config Change: -
 EUT Voltage: POE

Channel: 149 - 5745MHz Power Setting: 19
 Tx Chain: 4Tx
 Mode: n20
 Data Rate: MSC8

5725 MHz Band Edge Signal Radiated Field Strength

Frequency	Level	Pol	15.E		Detector	Azimuth	Height	Comments
MHz	dB μ V/m	v/h	Limit	Margin	Pk/QP/Avg	degrees	meters	
Power setting :19								
5724.820	77.0	V	78.3	-1.3	PK	264	2.3	POS; RB 1 MHz; VB: 3 MHz
5724.940	70.6	H	78.3	-7.7	PK	261	2.0	POS; RB 1 MHz; VB: 3 MHz

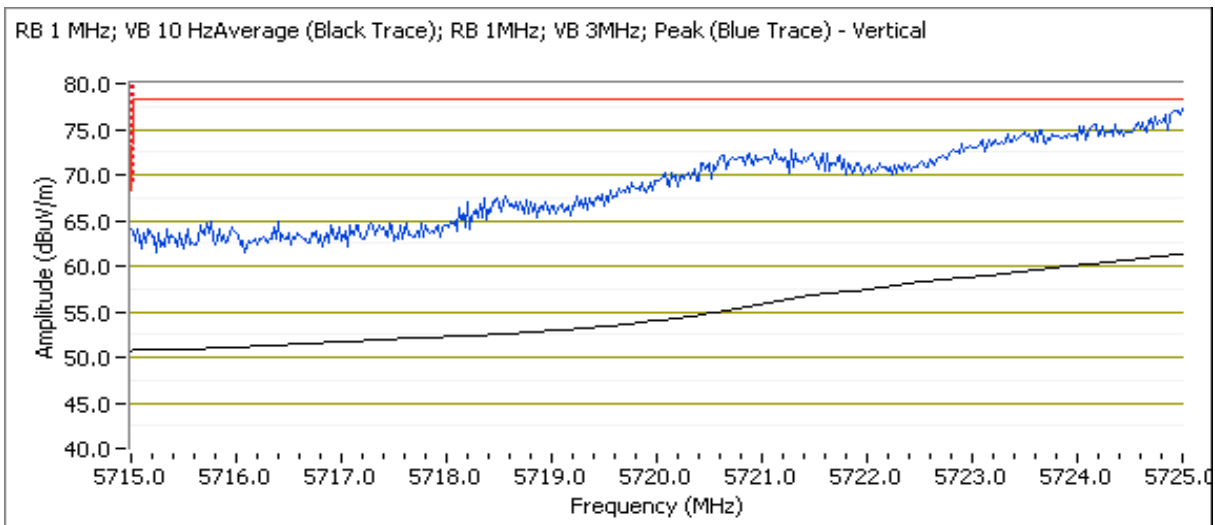



EMC Test Data

Client: Vivint Wireless	Job Number: J96091
Model: 1520 (4x4 5GHz 802.11 Client)	T-Log Number: T96173
Contact: Venkat Kalkunte	Project Manager: Irene Rademacher
Standard: FCC 15.B / 15.407 (New Rules)	Project Coordinator: -
	Class: N/A

5715 MHz Band Edge Signal Radiated Field Strength

Frequency	Level	Pol	15.E		Detector	Azimuth	Height	Comments
MHz	dB μ V/m	v/h	Limit	Margin	Pk/QP/Avg	degrees	meters	
Power setting :19								
5714.820	63.6	V	68.3	-4.7	PK	263	2.3	POS; RB 1 MHz; VB: 3 MHz
5710.670	59.3	H	68.3	-9.0	PK	255	2.0	POS; RB 1 MHz; VB: 3 MHz

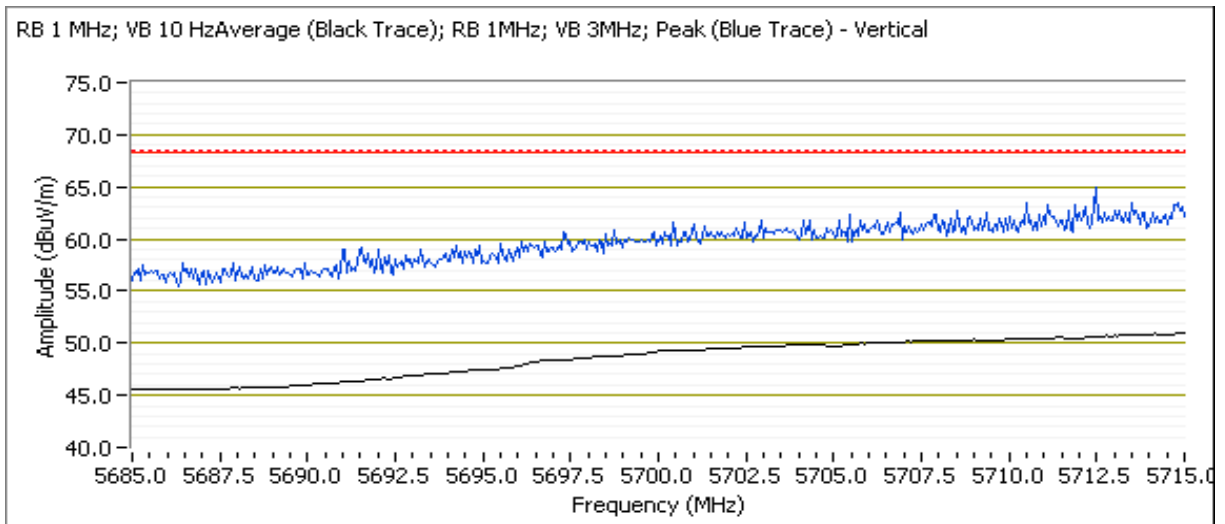



EMC Test Data

Client: Vivint Wireless	Job Number: J96091
Model: 1520 (4x4 5GHz 802.11 Client)	T-Log Number: T96173
	Project Manager: Irene Rademacher
Contact: Venkat Kalkunte	Project Coordinator: -
Standard: FCC 15.B / 15.407 (New Rules)	Class: N/A

Channel: 165 - 5825MHz Power Setting: 21
 Tx Chain: 4Tx
 Mode: n20
 Data Rate: MSC8

5850 MHz Band Edge Signal Radiated Field Strength

Frequency	Level	Pol	15.E		Detector	Azimuth	Height	Comments
MHz	dB μ V/m	v/h	Limit	Margin	Pk/QP/Avg	degrees	meters	
5850.360	76.2	V	78.3	-2.1	PK	250	1.8	POS; RB 1 MHz; VB: 3 MHz
5850.320	71.2	H	78.3	-7.1	PK	266	1.7	POS; RB 1 MHz; VB: 3 MHz

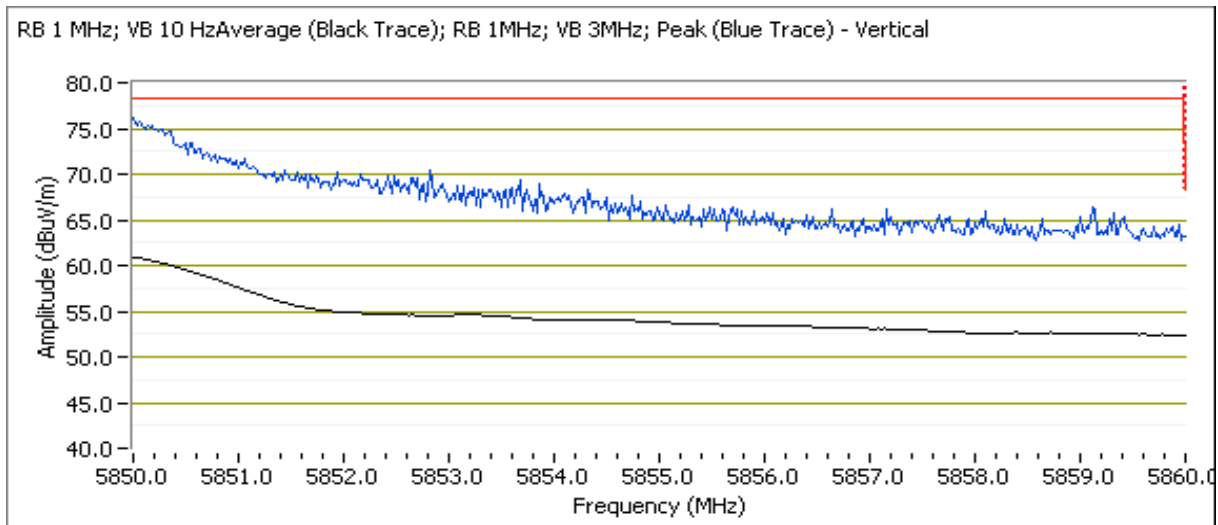



EMC Test Data

Client: Vivint Wireless	Job Number: J96091
Model: 1520 (4x4 5GHz 802.11 Client)	T-Log Number: T96173
	Project Manager: Irene Rademacher
Contact: Venkat Kalkunte	Project Coordinator: -
Standard: FCC 15.B / 15.407 (New Rules)	Class: N/A

5860 MHz Band Edge Signal Radiated Field Strength

Frequency MHz	Level dB μ V/m	Pol v/h	15.E		Detector Pk/QP/Avg	Azimuth degrees	Height meters	Comments
			Limit	Margin				
5863.010	66.2	V	68.3	-2.1	PK	255	1.8	POS; RB 1 MHz; VB: 3 MHz
5865.770	61.2	H	68.3	-7.1	PK	261	2.0	POS; RB 1 MHz; VB: 3 MHz

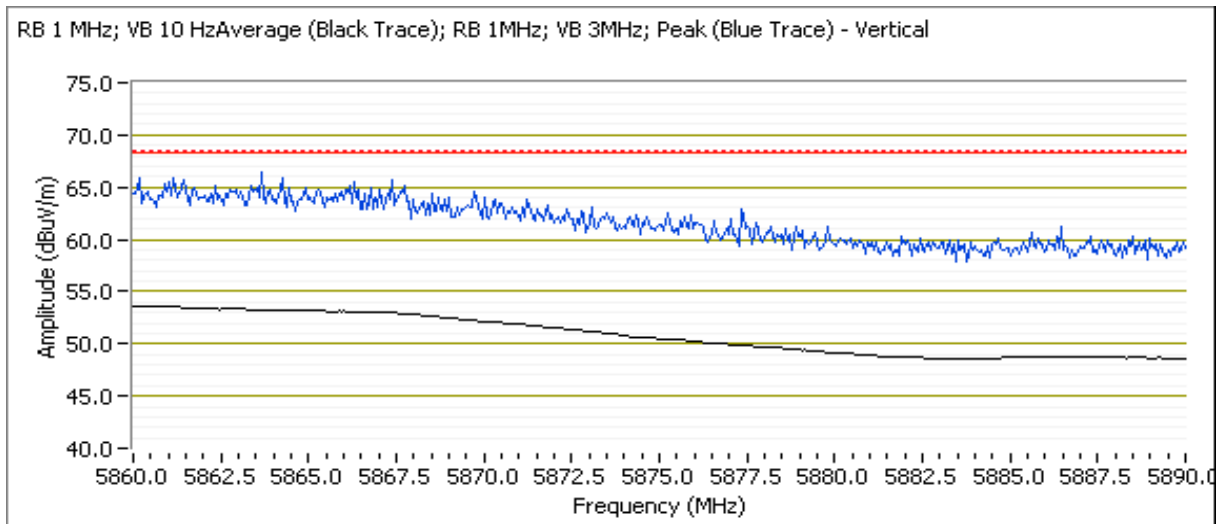



EMC Test Data

Client: Vivint Wireless	Job Number: J96091
Model: 1520 (4x4 5GHz 802.11 Client)	T-Log Number: T96173
	Project Manager: Irene Rademacher
Contact: Venkat Kalkunte	Project Coordinator: -
Standard: FCC 15.B / 15.407 (New Rules)	Class: N/A

RSS 210 and FCC 15.407 (UNII) Radiated Spurious Emissions

Test Specific Details

Objective: The objective of this test session is to perform final qualification testing of the EUT with respect to the specification listed above.

General Test Configuration

The EUT and all local support equipment were located on the turntable for radiated spurious emissions testing. For radiated emissions testing the measurement antenna was located 3 meters from the EUT, unless otherwise noted.

Ambient Conditions:

Temperature: 21.8 °C
Rel. Humidity: 40 %

Summary of Results

Run #	Mode	Channel	Target Power Setting	Passing Power Setting	Test Performed	Limit	Result / Margin
1	n40	38 - 5190MHz	21	14	Restricted Band Edge at 5150 MHz	15.209	53.6 dBµV/m @ 5150.0 MHz (-0.4 dB)
	n40	46 - 5230MHz	21	21	Restricted Band Edge at 5150 MHz	15.209	50.6 dBµV/m @ 5150.0 MHz (-3.4 dB)
2	n40	62 - 5310MHz	21	17	Restricted Band Edge at 5350 MHz	15.209	52.6 dBµV/m @ 5350.0 MHz (-1.4 dB)
	n40	54 - 5270MHz	21	21	Restricted Band Edge at 5350 MHz	15.209	50.4 dBµV/m @ 5350.0 MHz (-3.6 dB)
3	n40	102 - 5510MHz	21	15	Restricted Band Edge at 5460 MHz	15.209	50.0 dBµV/m @ 5460.0 MHz (-4.0 dB)
	n40	102 - 5510MHz	21	15	Band Edge 5460 - 5470 MHz	15E	53.7 dBµV/m @ 5470.0 MHz (-0.3 dB)
	n40	134 - 5670MHz	21	20	Band Edge 5725MHz	15E	52.6 dBµV/m @ 5725.9 MHz (-1.4 dB)
4	n40	151 - 5755MHz	21	16	Band Edge 5725MHz	15E	77.4 dBµV/m @ 5719.9 MHz (-0.9 dB)
	Band Edge 5715MHz				15E	67.1 dBµV/m @ 5710.3 MHz (-1.2 dB)	
	n40	159 - 5795MHz	21	20	Band Edge 5850MHz	15E	71.3 dBµV/m @ 5851.6 MHz (-7.0 dB)
	n40				Band Edge 5860MHz	15E	66.7 dBµV/m @ 5870.8 MHz (-1.6 dB)

Client: Vivint Wireless	Job Number: J96091
Model: 1520 (4x4 5GHz 802.11 Client)	T-Log Number: T96173
	Project Manager: Irene Rademacher
Contact: Venkat Kalkunte	Project Coordinator: -
Standard: FCC 15.B / 15.407 (New Rules)	Class: N/A

Modifications Made During Testing

No modifications were made to the EUT during testing

Deviations From The Standard

No deviations were made from the requirements of the standard.

Procedure Comments:

Measurements performed in accordance with FCC KDB 789033

Peak measurements performed with: RBW=1MHz, VBW=3MHz, peak detector, max hold, auto sweep time

Unless otherwise stated/noted, emission has duty cycle $\geq 98\%$ and was measured using RBW=1MHz, VBW=10Hz, peak detector, linear average mode, auto sweep time, max hold.

Mode	Data Rate	Duty Cycle (x)	Constant DC?	T (ms)	Pwr Cor Factor*	Lin Volt Cor Factor**	Min VBW for FS (Hz)
n40	13.5	94.3%	yes	1.27	0.26	0.51	787

Sample Notes

Sample S/N: Prototype

Driver: -

Antenna: 6dBi

Measurement Specific Notes:

Note 1:	For emissions outside of the restricted bands the limit is -27dBm/MHz eirp (68.3dBuV/m). The measurement method required is a peak measurement (RB=1MHz, VB \geq 3MHz, peak detector). Per KDB 789033 2) c) (i), compliance can be demonstrated by meeting the average and peak limits of 15.209, as an alternative.
Note 2:	Emission has duty cycle $\geq 98\%$, average measurement performed: RBW=1MHz, VBW=3MHz, RMS, Power averaging, auto sweep, trace average 100 traces
Note 3:	Emission has duty cycle $< 98\%$, but constant, average measurement performed: RBW=1MHz, VBW=10Hz, peak detector, linear averaging, auto sweep, trace average $100 * 1/DC$ traces, measurement corrected by Linear Voltage correction factor
Note 4:	Emission has duty cycle $< 98\%$ and is NOT constant, average measurement performed: RBW=1MHz, VBW $> 1/T$, peak detector, linear average mode, sweep time auto, max hold. Max hold for $50*(1/DC)$ traces
Note 5:	Emission has duty cycle $< 98\%$, but constant, average measurement performed: RBW=1MHz, VBW=3MHz, RMS, Power averaging, auto sweep, trace average $100 * 1/DC$ traces, measurement corrected by Pwr correction factor
Note 6:	Plots of the average and peak bandedge do not account for any duty cycle correction. Refer to the tabluar results for final measurements.



EMC Test Data

Client: Vivint Wireless	Job Number: J96091
Model: 1520 (4x4 5GHz 802.11 Client)	T-Log Number: T96173
	Project Manager: Irene Rademacher
Contact: Venkat Kalkunte	Project Coordinator: -
Standard: FCC 15.B / 15.407 (New Rules)	Class: N/A

Run #1: Radiated Bandedge Measurements, 5150-5250MHz

Date of Test: 10/27/2014 0:00
 Test Engineer: Rafael Varelas
 Test Location: FT Chamber #4

Config. Used: 1
 Config Change: -
 EUT Voltage: POE

Channel: 38 - 5190 MHz
 Tx Chain: 4Tx
 Mode: n40
 Data Rate: MCS8

5150 MHz Band Edge Signal Radiated Field Strength

Frequency	Level	Pol	FCC 15.209		Detector	Azimuth	Height	Comments
MHz	dB μ V/m	v/h	Limit	Margin	PK/QP/Avg	degrees	meters	
5150.000	53.6	V	54.0	-0.4	AVG	261	2.0	Note 3, pwr = 14
5148.000	66.3	V	74.0	-7.7	PK	261	2.0	pwr= 14
5150.000	48.7	H	54.0	-5.3	AVG	260	1.9	Note 3, pwr = 14
5144.710	61.3	H	74.0	-12.7	PK	260	1.9	pwr= 14

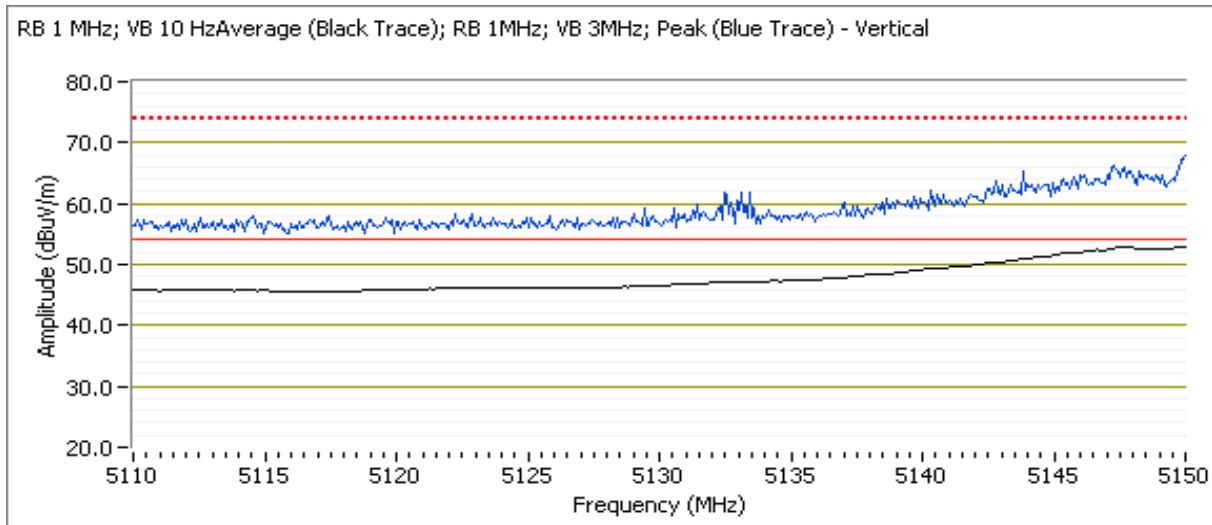



EMC Test Data

Client: Vivint Wireless	Job Number: J96091
Model: 1520 (4x4 5GHz 802.11 Client)	T-Log Number: T96173
	Project Manager: Irene Rademacher
Contact: Venkat Kalkunte	Project Coordinator: -
Standard: FCC 15.B / 15.407 (New Rules)	Class: N/A

Channel: 46 - 5230 MHz
 Tx Chain: 4Tx
 Mode: n40
 Data Rate: MCS8

5150 MHz Band Edge Signal Radiated Field Strength

Frequency MHz	Level dB μ V/m	Pol v/h	FCC 15.209		Detector Pk/QP/Avg	Azimuth degrees	Height meters	Comments
			Limit	Margin				
5150.000	50.6	V	54.0	-3.4	AVG	255	1.9	Note 3, pwr = 21
5133.490	65.1	V	74.0	-8.9	PK	255	1.9	pwr= 21
5150.000	46.1	H	54.0	-7.9	AVG	259	1.9	Note 3, pwr = 21
5143.110	57.9	H	74.0	-16.1	PK	259	1.9	pwr= 21

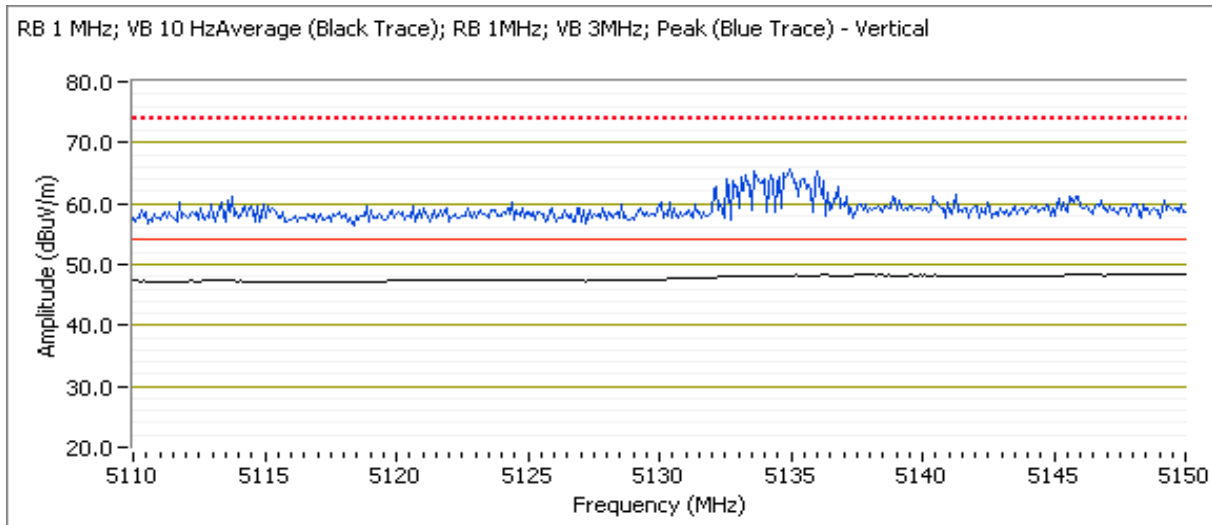



EMC Test Data

Client: Vivint Wireless	Job Number: J96091
Model: 1520 (4x4 5GHz 802.11 Client)	T-Log Number: T96173
	Project Manager: Irene Rademacher
Contact: Venkat Kalkunte	Project Coordinator: -
Standard: FCC 15.B / 15.407 (New Rules)	Class: N/A

Run #2: Radiated Bandedge Measurements, 5250-5350MHz

Date of Test: 10/27/2014 0:00
 Test Engineer: Rafael Varelas
 Test Location: FT Chamber #4

Config. Used: 1
 Config Change: -
 EUT Voltage: POE

Channel: 62 - 5310MHz
 Tx Chain: 4Tx
 Mode: n40
 Data Rate: MCS8

5350 MHz Band Edge Signal Radiated Field Strength

Frequency MHz	Level dB μ V/m	Pol v/h	FCC 15.209		Detector Pk/QP/Avg	Azimuth degrees	Height meters	Comments
			Limit	Margin				
5350.000	52.6	V	54.0	-1.4	AVG	249	1.6	Note 3, pwr = 17
5350.080	71.4	V	74.0	-2.6	PK	249	1.6	pwr= 17
5350.000	51.0	H	54.0	-3.0	AVG	256	1.9	Note 3, pwr = 17
5352.480	70.6	H	74.0	-3.4	PK	256	1.9	pwr= 17

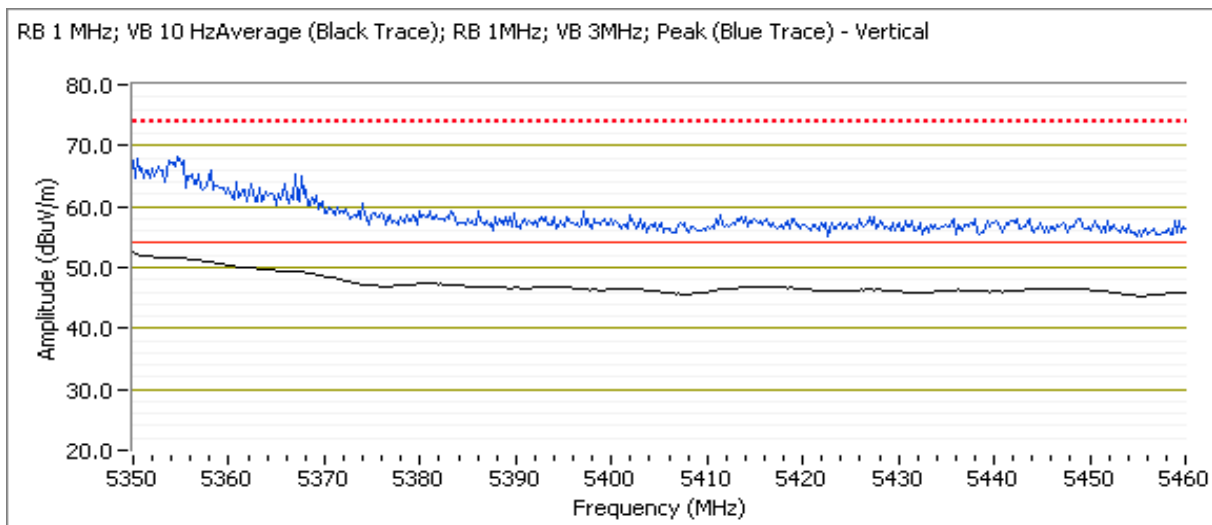



EMC Test Data

Client: Vivint Wireless	Job Number: J96091
Model: 1520 (4x4 5GHz 802.11 Client)	T-Log Number: T96173
	Project Manager: Irene Rademacher
Contact: Venkat Kalkunte	Project Coordinator: -
Standard: FCC 15.B / 15.407 (New Rules)	Class: N/A

Channel: 54 - 5270MHz
 Tx Chain: 4Tx
 Mode: n40
 Data Rate: MCS8

5350 MHz Band Edge Signal Radiated Field Strength

Frequency	Level	Pol	FCC 15.209		Detector	Azimuth	Height	Comments
MHz	dB μ V/m	v/h	Limit	Margin	Pk/QP/Avg	degrees	meters	
5350.000	50.4	V	54.0	-3.6	AVG	265	2.1	Note 3, pwr = 21
5356.970	62.5	V	74.0	-11.5	PK	265	2.1	pwr= 21
5350.000	47.9	H	54.0	-6.1	AVG	257	1.8	Note 3, pwr = 21
5350.000	59.1	H	74.0	-14.9	PK	257	1.8	pwr= 21

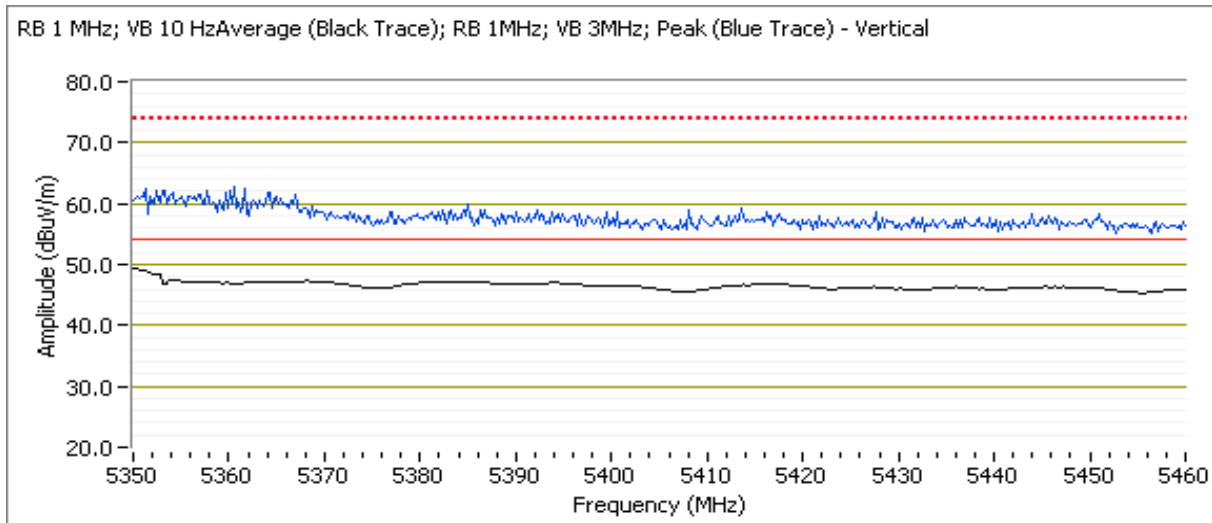



EMC Test Data

Client: Vivint Wireless	Job Number: J96091
Model: 1520 (4x4 5GHz 802.11 Client)	T-Log Number: T96173
	Project Manager: Irene Rademacher
Contact: Venkat Kalkunte	Project Coordinator: -
Standard: FCC 15.B / 15.407 (New Rules)	Class: N/A

Run #3: Radiated Bandedge Measurements, 5470-5725MHz

Date of Test: 10/27/2014 0:00
 Test Engineer: Rafael Varelas
 Test Location: FT Chamber #4

Config. Used: 1
 Config Change: -
 EUT Voltage: POE

Channel: 102 - 5510MHz
 Tx Chain: 4Tx
 Mode: n40
 Data Rate: MCS8

5460 MHz Band Edge Signal Radiated Field Strength

Frequency MHz	Level dB μ V/m	Pol v/h	FCC 15.209		Detector Pk/QP/Avg	Azimuth degrees	Height meters	Comments
			Limit	Margin				
5460.000	50.0	V	54.0	-4.0	AVG	263	1.9	Note 3, pwr = 15
5458.560	62.5	V	74.0	-11.5	PK	263	1.9	pwr= 15
5460.000	45.7	H	54.0	-8.3	AVG	258	2.0	Note 3, pwr = 15
5451.180	56.2	H	74.0	-17.8	PK	258	2.0	pwr= 15

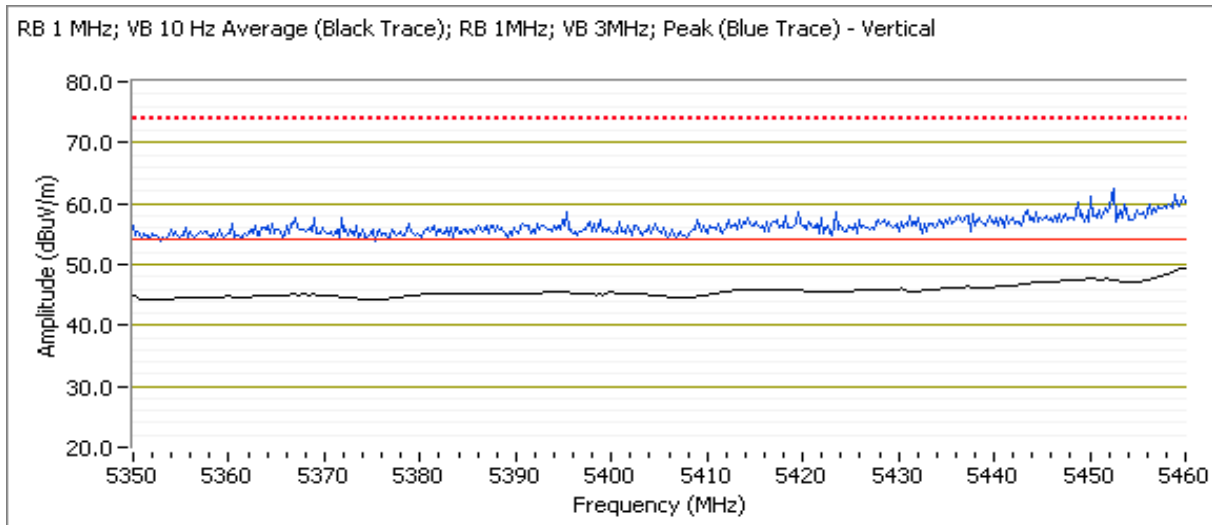



EMC Test Data

Client: Vivint Wireless	Job Number: J96091
Model: 1520 (4x4 5GHz 802.11 Client)	T-Log Number: T96173
Contact: Venkat Kalkunte	Project Manager: Irene Rademacher
Standard: FCC 15.B / 15.407 (New Rules)	Project Coordinator: -
	Class: N/A

5470 MHz Band Edge Signal Radiated Field Strength

Frequency MHz	Level dB μ V/m	Pol v/h	15.E		Detector Pk/QP/Avg	Azimuth degrees	Height meters	Comments
			Limit	Margin				
5470.000	53.7	V	54.0	-0.3	AVG	263	1.9	Note 3, pwr = 15
5469.620	67.5	V	74.0	-6.5	PK	263	1.9	pwr= 15
5470.000	48.2	H	54.0	-5.8	AVG	258	2.0	Note 3, pwr = 15
5466.370	65.9	H	74.0	-8.1	PK	258	2.0	pwr= 15

RB 1 MHz; VB 10 Hz Average (Black Trace); RB 1MHz; VB 3MHz; Peak (Blue Trace) - Vertical

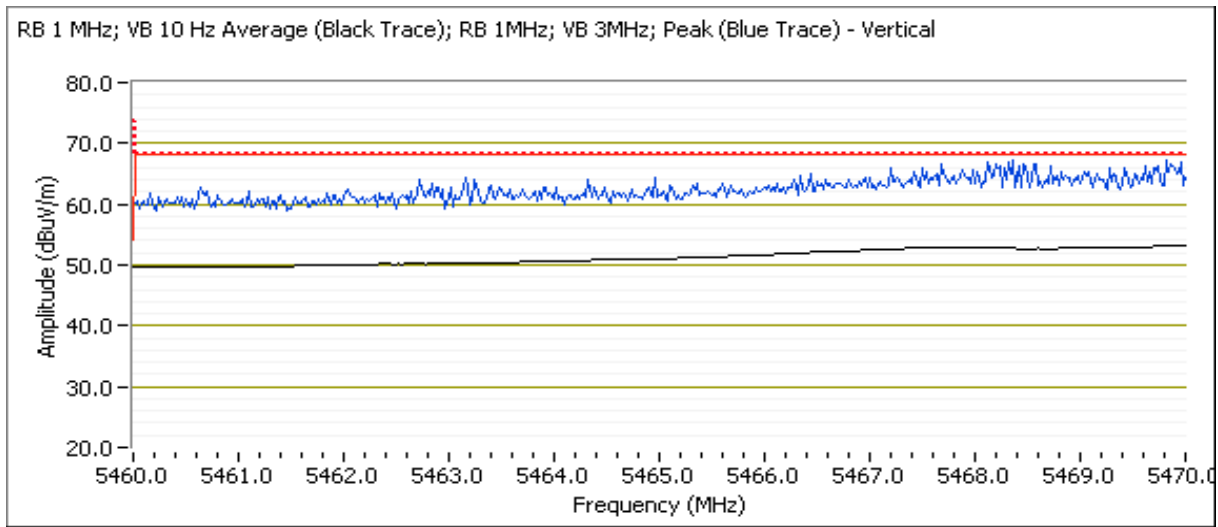



EMC Test Data

Client: Vivint Wireless	Job Number: J96091
Model: 1520 (4x4 5GHz 802.11 Client)	T-Log Number: T96173
	Project Manager: Irene Rademacher
Contact: Venkat Kalkunte	Project Coordinator: -
Standard: FCC 15.B / 15.407 (New Rules)	Class: N/A

Channel: 134 - 5670MHz
 Tx Chain: 4Tx
 Mode: n40
 Data Rate: MCS8

5725 MHz Band Edge Signal Radiated Field Strength

Frequency MHz	Level dB μ V/m	Pol v/h	15.E		Detector Pk/QP/Avg	Azimuth degrees	Height meters	Comments
			Limit	Margin				
5725.880	52.6	V	54.0	-1.4	AVG	254	1.7	Note 3, pwr=20
5728.050	68.6	V	74.0	-5.4	PK	254	1.7	pwr=20
5725.080	49.6	H	54.0	-4.4	AVG	255	2.2	Note 3, pwr=20
5733.020	62.4	H	74.0	-11.6	PK	255	2.2	pwr=20

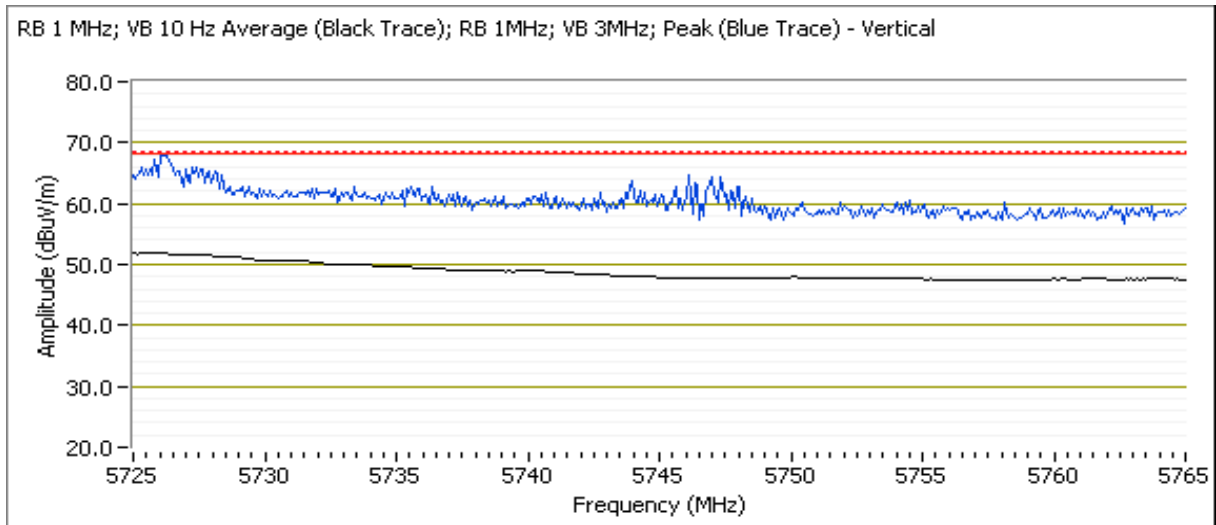



EMC Test Data

Client: Vivint Wireless	Job Number: J96091
Model: 1520 (4x4 5GHz 802.11 Client)	T-Log Number: T96173
	Project Manager: Irene Rademacher
Contact: Venkat Kalkunte	Project Coordinator: -
Standard: FCC 15.B / 15.407 (New Rules)	Class: N/A

Run #4: Radiated Bandedge Measurements, 5725-5850MHz

Date of Test: 10/27/2014 0:00
 Test Engineer: Rafael Varelas
 Test Location: FT Chamber #4

Config. Used: 1
 Config Change: -
 EUT Voltage: POE

Channel: 151 - 5755MHz
 Tx Chain: 4Tx
 Mode: n40
 Data Rate: MCS8

5725 MHz Band Edge Signal Radiated Field Strength

Frequency MHz	Level dB μ V/m	Pol v/h	15.E		Detector Pk/QP/Avg	Azimuth degrees	Height meters	Comments
			Limit	Margin				
5719.910	77.4	V	78.3	-0.9	PK	259	2.0	pwr=16
5719.710	69.4	H	78.3	-8.9	PK	257	2.0	pwr=16

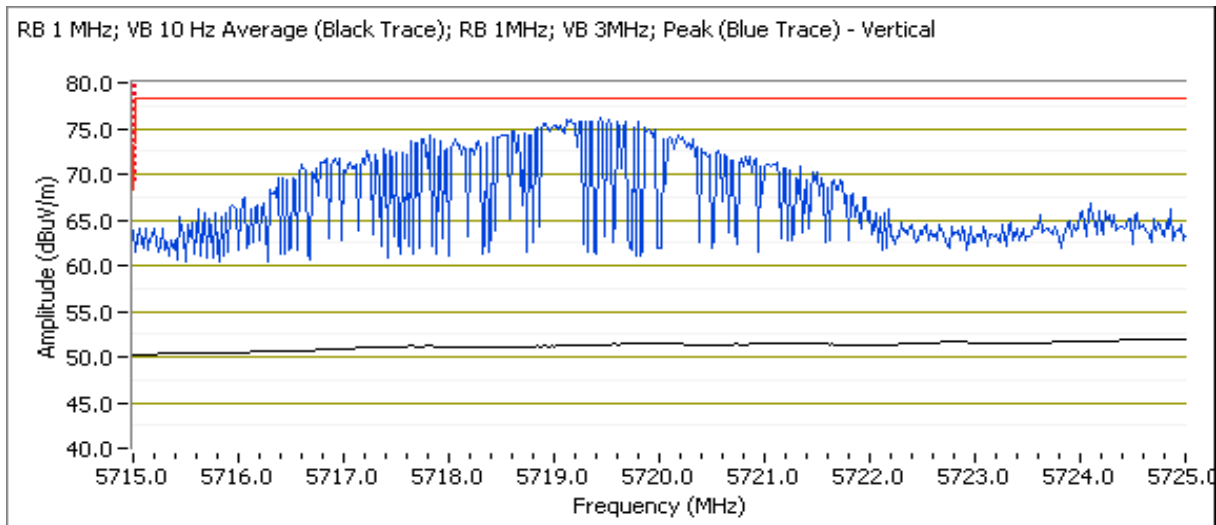



EMC Test Data

Client: Vivint Wireless	Job Number: J96091
Model: 1520 (4x4 5GHz 802.11 Client)	T-Log Number: T96173
Contact: Venkat Kalkunte	Project Manager: Irene Rademacher
Standard: FCC 15.B / 15.407 (New Rules)	Project Coordinator: -
	Class: N/A

5715 MHz Band Edge Signal Radiated Field Strength

Frequency MHz	Level dB μ V/m	Pol v/h	15.E		Detector Pk/QP/Avg	Azimuth degrees	Height meters	Comments
			Limit	Margin				
5710.310	67.1	V	68.3	-1.2	PK	259	2.0	pwr=16
5713.080	64.4	H	68.3	-3.9	PK	257	2.0	pwr=16

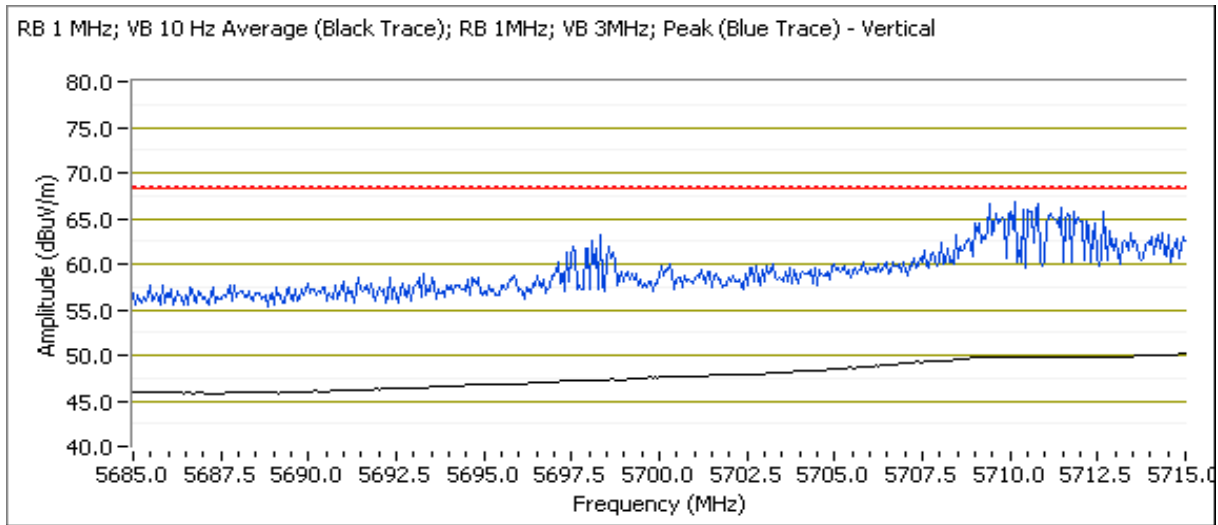



EMC Test Data

Client: Vivint Wireless	Job Number: J96091
Model: 1520 (4x4 5GHz 802.11 Client)	T-Log Number: T96173
	Project Manager: Irene Rademacher
Contact: Venkat Kalkunte	Project Coordinator: -
Standard: FCC 15.B / 15.407 (New Rules)	Class: N/A

Channel: 159 - 5795MHz
 Tx Chain: 4Tx
 Mode: n40
 Data Rate: MCS8

5850 MHz Band Edge Signal Radiated Field Strength

Frequency	Level	Pol	15.E		Detector	Azimuth	Height	Comments
MHz	dB μ V/m	v/h	Limit	Margin	Pk/QP/Avg	degrees	meters	
5851.580	71.3	V	78.3	-7.0	PK	258	1.9	pwr=20
5854.670	63.4	H	78.3	-14.9	PK	256	1.9	pwr=20

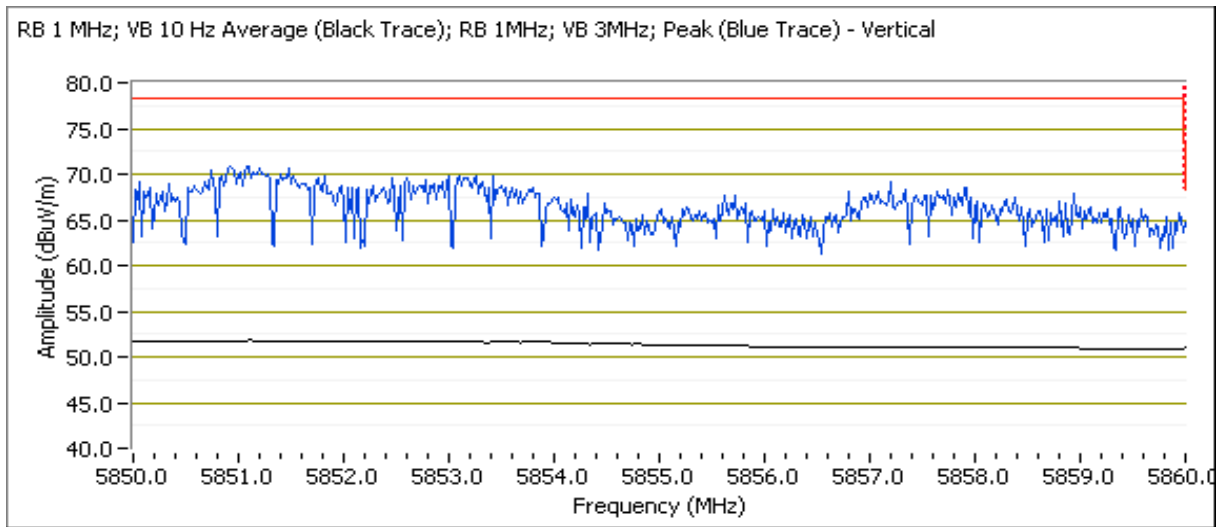



EMC Test Data

Client: Vivint Wireless	Job Number: J96091
Model: 1520 (4x4 5GHz 802.11 Client)	T-Log Number: T96173
Contact: Venkat Kalkunte	Project Manager: Irene Rademacher
Standard: FCC 15.B / 15.407 (New Rules)	Project Coordinator: -
	Class: N/A

5860 MHz Band Edge Signal Radiated Field Strength

Frequency MHz	Level dB μ V/m	Pol v/h	15.E		Detector Pk/QP/Avg	Azimuth degrees	Height meters	Comments
			Limit	Margin				
5870.820	66.7	V	68.3	-1.6	PK	258	1.9	pwr=20
5860.600	62.7	H	68.3	-5.6	PK	256	1.9	pwr=20

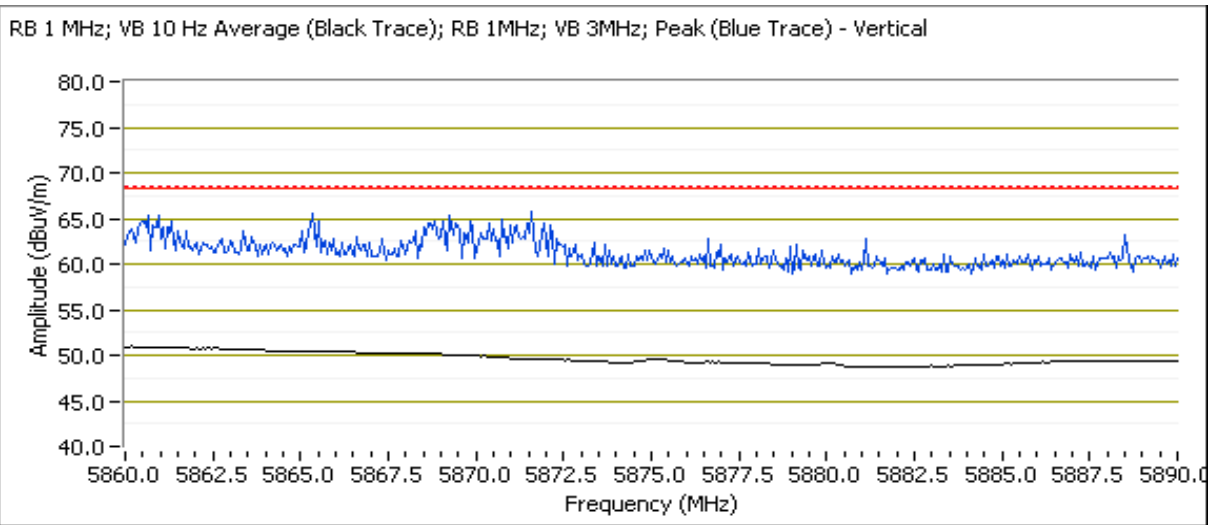



EMC Test Data

Client: Vivint Wireless	Job Number: J96091
Model: 1520 (4x4 5GHz 802.11 Client)	T-Log Number: T96173
	Project Manager: Irene Rademacher
Contact: Venkat Kalkunte	Project Coordinator: -
Standard: FCC 15.B / 15.407 (New Rules)	Class: N/A

RSS 210 and FCC 15.407 (UNII) Radiated Spurious Emissions

Test Specific Details

Objective: The objective of this test session is to perform final qualification testing of the EUT with respect to the specification listed above.

General Test Configuration

The EUT and all local support equipment were located on the turntable for radiated spurious emissions testing. For radiated emissions testing the measurement antenna was located 3 meters from the EUT, unless otherwise noted.

Ambient Conditions: Temperature: 18-20 °C
Rel. Humidity: 30-40 %

Summary of Results

Run #	Mode	Channel	Target Power Setting	Passing Power Setting	Test Performed	Limit	Result / Margin
1	ac80	42 - 5210MHz	21	11	Restricted Band Edge at 5150 MHz	15.209	52.5 dBµV/m @ 5134.0 MHz (-1.5 dB)
2	ac80	58 - 5290MHz	21	13	Restricted Band Edge at 5350 MHz	15.209	53.2 dBµV/m @ 5359.9 MHz (-0.8 dB)
3	ac80	106 - 5530MHz	21	12	Restricted Band Edge at 5460 MHz	15.209	51.8 dBµV/m @ 5452.5 MHz (-2.2 dB)
					Band Edge 5460 - 5470 MHz	15E	62.5 dBµV/m @ 5466.3 MHz (-5.8 dB)
4	ac80	155 - 5775MHz	21	14	Band Edge 5725MHz	15E	71.1 dBµV/m @ 5724.3 MHz (-7.2 dB)
	ac80				Band Edge 5715MHz	15E	60.7 dBµV/m @ 5705.0 MHz (-7.6 dB)
	ac80	155 - 5775MHz	21	14	Band Edge 5850MHz	15E	63.8 dBµV/m @ 5858.3 MHz (-14.5 dB)
	ac80				Band Edge 5860MHz	15E	66.7 dBµV/m @ 5866.3 MHz (-1.6 dB)

Modifications Made During Testing

No modifications were made to the EUT during testing

Deviations From The Standard

No deviations were made from the requirements of the standard.



EMC Test Data

Client: Vivint Wireless	Job Number: J96091
Model: 1520 (4x4 5GHz 802.11 Client)	T-Log Number: T96173
	Project Manager: Irene Rademacher
Contact: Venkat Kalkunte	Project Coordinator: -
Standard: FCC 15.B / 15.407 (New Rules)	Class: N/A

Procedure Comments:

Measurements performed in accordance with FCC KDB 789033
 Peak measurements performed with: RBW=1MHz, VBW=3MHz, peak detector, max hold, auto sweep time
 Unless otherwise stated/noted, emission has duty cycle $\geq 98\%$ and was measured using RBW=1MHz, VBW=10Hz, peak detector, linear average mode, auto sweep time, max hold.

Mode	Data Rate	Duty Cycle (x)	Constant DC?	T (ms)	Pwr Cor Factor*	Lin Volt Cor Factor**	Min VBW for FS (Hz)
11ac80	MCS8	92.1%	yes	0.58	0.36	0.72	1724

Sample Notes

Sample S/N: Prototype
 Driver: -
 Antenna: 6dBi

Measurement Specific Notes:

Note 1:	For emissions outside of the restricted bands the limit is -27dBm/MHz eirp (68.3dBuV/m). The measurement method required is a peak measurement (RB=1MHz, VB \geq 3MHz, peak detector). Per KDB 789033 2) c) (i), compliance can be demonstrated by meeing the average and peak limits of 15.209, as an alternative.
Note 2:	Emission has duty cycle $\geq 98\%$, average measurement performed: RBW=1MHz, VBW=3MHz, RMS, Power averaging, auto sweep, trace average 100 traces
Note 3:	Emission has duty cycle $< 98\%$, but constant, average measurement performed: RBW=1MHz, VBW=10Hz, peak detector, linear averaging, auto sweep, trace average 100 * 1/DC traces, measurement corrected by Linear Voltage correction factor
Note 4:	Emission has duty cycle $< 98\%$ and is NOT constant, average measurement performed: RBW=1MHz, VBW $>$ 1/T, peak detector, linear average mode, sweep time auto, max hold. Max hold for 50*(1/DC) traces
Note 5:	Emission has duty cycle $< 98\%$, but constant, average measurement performed: RBW=1MHz, VBW=3MHz, RMS, Power averaging, auto sweep, trace average 100 * 1/DC traces, measurement corrected by Pwr correction factor
Note 6:	Plots of the average and peak bandedge do not account for any duty cycle correction. Refer to the tabluar results for final measurements.

EUT Voltage: POE

Config. Used: 1



EMC Test Data

Client: Vivint Wireless	Job Number: J96091
Model: 1520 (4x4 5GHz 802.11 Client)	T-Log Number: T96173
	Project Manager: Irene Rademacher
Contact: Venkat Kalkunte	Project Coordinator: -
Standard: FCC 15.B / 15.407 (New Rules)	Class: N/A

Run #1: Radiated Bandedge Measurements, 5150-5250MHz

Date of Test: 12/10/14

Test Location: Chamber #4

Test Engineer: M. Birgani

EUT Voltage: POE

Channel: 42 - 5210MHz

Power Setting: 11

Tx Chain: 4Tx

Data Rate: MCS 8

Mode: AC80

Packet Size: 1000

5150 MHz Band Edge Signal Radiated Field Strength

Frequency MHz	Level dB μ V/m	Pol v/h	FCC 15.209		Detector Pk/QP/Avg	Azimuth degrees	Height meters	Comments
			Limit	Margin				
5133.970	52.5	V	54.0	-1.5	AVG	112	1.9	POS; RB 1 MHz; VB: 10 Hz, Note 3
5147.270	46.9	H	54.0	-7.1	AVG	112	1.5	POS; RB 1 MHz; VB: 10 Hz, Note 3
5133.490	64.3	V	74.0	-9.7	PK	112	1.9	POS; RB 1 MHz; VB: 3 MHz
5148.160	58.9	H	74.0	-15.1	PK	112	1.5	POS; RB 1 MHz; VB: 3 MHz

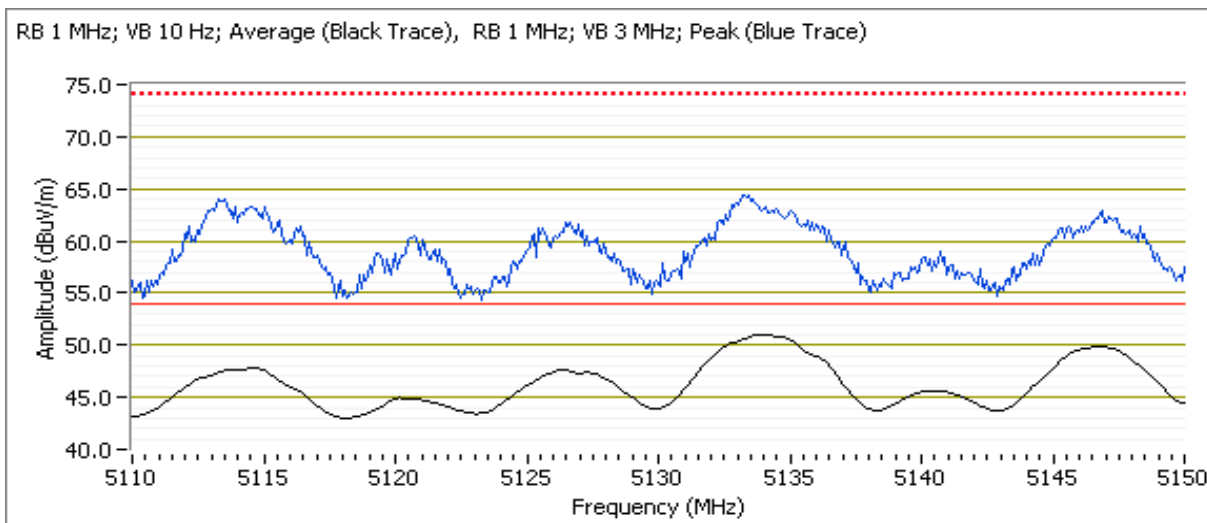



EMC Test Data

Client: Vivint Wireless	Job Number: J96091
Model: 1520 (4x4 5GHz 802.11 Client)	T-Log Number: T96173
	Project Manager: Irene Rademacher
Contact: Venkat Kalkunte	Project Coordinator: -
Standard: FCC 15.B / 15.407 (New Rules)	Class: N/A

Run #2: Radiated Bandedge Measurements, 5250-5350MHz

Date of Test: 12/10/14

Test Location: Chamber #4

Test Engineer: M. Birgani

EUT Voltage: POE

Channel: 58 - 5290MHz

Power Setting: 13

Tx Chain: 4Tx

Data Rate: MCS 8

Mode: AC80

Packet Size: 1000

5350 MHz Band Edge Signal Radiated Field Strength

Frequency MHz	Level dB μ V/m	Pol v/h	FCC 15.209		Detector Pk/QP/Avg	Azimuth degrees	Height meters	Comments
			Limit	Margin				
5359.940	53.2	V	54.0	-0.8	AVG	113	2.0	POS; RB 1 MHz; VB: 10 Hz, Note 3
5364.270	48.4	H	54.0	-6.3	AVG	113	2.0	POS; RB 1 MHz; VB: 10 Hz, Note 3
5359.540	67.3	V	74.0	-6.7	PK	113	2.0	POS; RB 1 MHz; VB: 3 MHz
5384.150	63.4	H	74.0	-10.6	PK	113	2.0	POS; RB 1 MHz; VB: 3 MHz

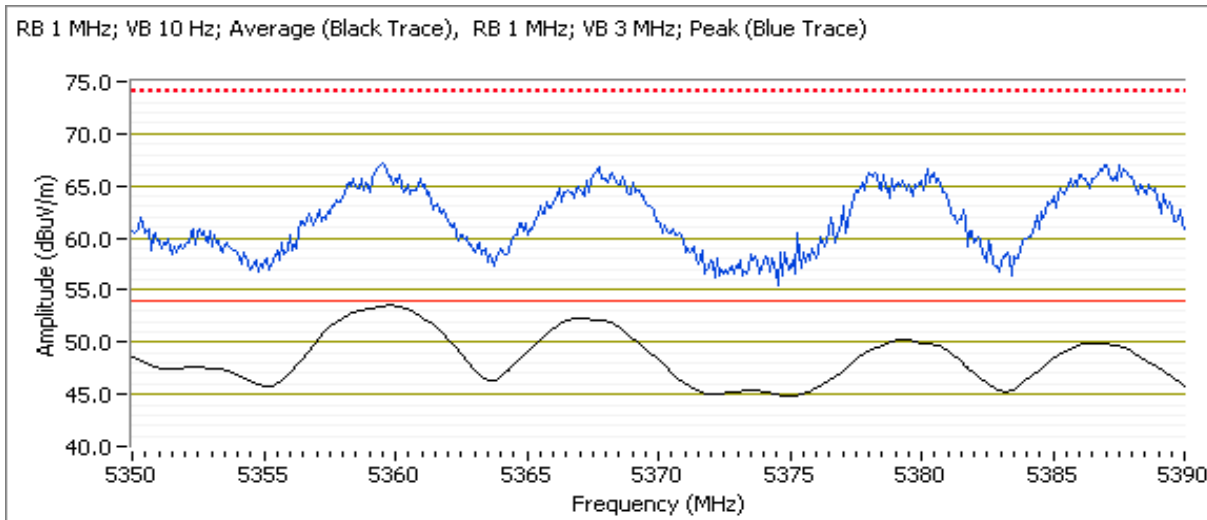



EMC Test Data

Client: Vivint Wireless	Job Number: J96091
Model: 1520 (4x4 5GHz 802.11 Client)	T-Log Number: T96173
	Project Manager: Irene Rademacher
Contact: Venkat Kalkunte	Project Coordinator: -
Standard: FCC 15.B / 15.407 (New Rules)	Class: N/A

Run #3: Radiated Bandedge Measurements, 5470-5725MHz

Date of Test: 12/10/14

Test Location: Chamber #4

Test Engineer: M. Birgani

EUT Voltage: POE

Channel: 106 - 5530 MHz

Power Setting: 12

Tx Chain: 4Tx

Data Rate: MCS 8

Mode: AC80

Packet Size: 1000

5460 MHz Band Edge Signal Radiated Field Strength

Frequency MHz	Level dB μ V/m	Pol v/h	FCC 15.209		Detector Pk/QP/Avg	Azimuth degrees	Height meters	Comments
			Limit	Margin				
5452.460	51.8	V	54.0	-2.2	AVG	113	1.8	POS; RB 1 MHz; VB: 10 Hz, Note 3
5446.130	46.8	H	54.0	-7.2	AVG	114	1.7	POS; RB 1 MHz; VB: 10 Hz, Note 3
5451.820	65.4	V	74.0	-8.6	PK	113	1.8	POS; RB 1 MHz; VB: 3 MHz
5445.010	60.4	H	74.0	-13.6	PK	114	1.7	POS; RB 1 MHz; VB: 3 MHz

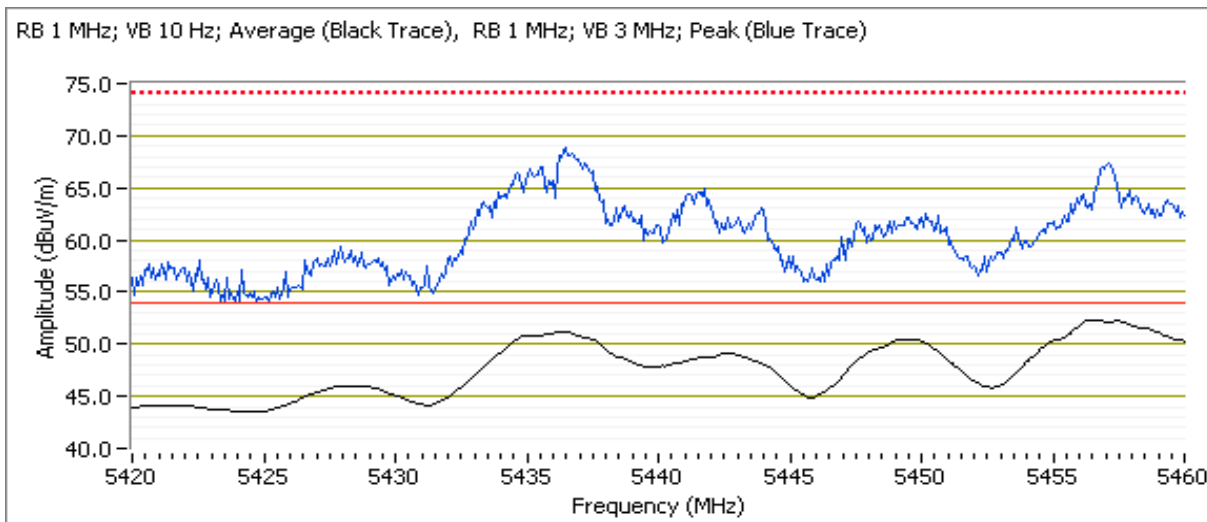

Client: Vivint Wireless	Job Number: J96091
Model: 1520 (4x4 5GHz 802.11 Client)	T-Log Number: T96173
	Project Manager: Irene Rademacher
Contact: Venkat Kalkunte	Project Coordinator: -
Standard: FCC 15.B / 15.407 (New Rules)	Class: N/A

5470 MHz Band Edge Signal Radiated Field Strength

Frequency MHz	Level dB μ V/m	Pol v/h	15.E		Detector Pk/QP/Avg	Azimuth degrees	Height meters	Comments
			Limit	Margin				
5466.250	62.5	V	68.3	-5.8	PK	113	1.8	POS; RB 1 MHz; VB: 3 MHz
5467.370	60.1	H	68.3	-8.2	PK	114	1.7	POS; RB 1 MHz; VB: 3 MHz

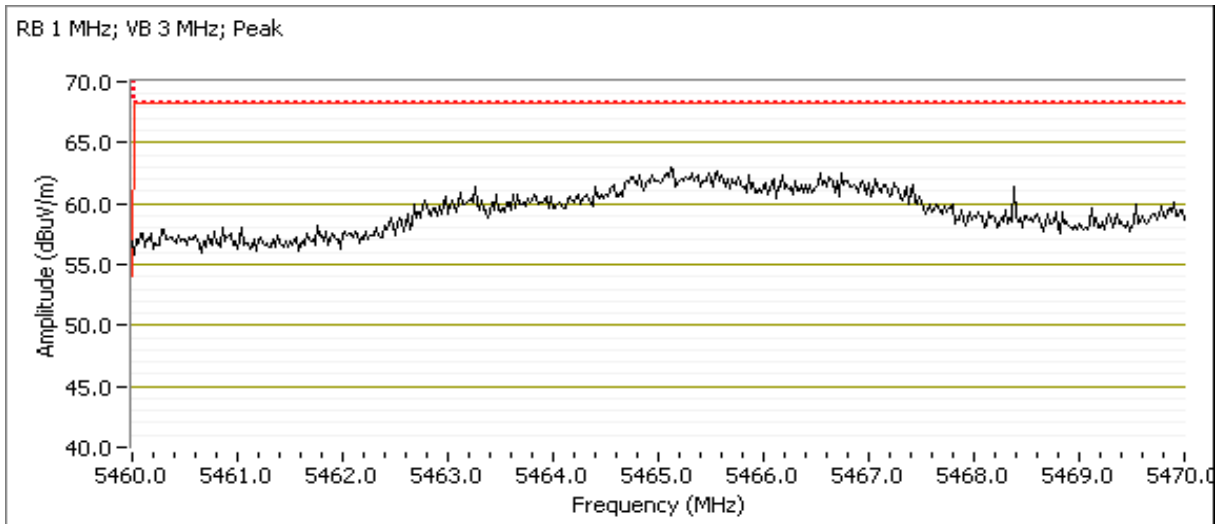



EMC Test Data

Client: Vivint Wireless	Job Number: J96091
Model: 1520 (4x4 5GHz 802.11 Client)	T-Log Number: T96173
	Project Manager: Irene Rademacher
Contact: Venkat Kalkunte	Project Coordinator: -
Standard: FCC 15.B / 15.407 (New Rules)	Class: N/A

Run #4: Radiated Bandedge Measurements, 5725-5850MHz

Date of Test: 12/10/14

Test Location: Chamber #4

Test Engineer: M. Birgani

EUT Voltage: POE

Channel: 155 - 5775MHz

Power Setting: 14

Tx Chain: 4Tx

Data Rate: MCS 8

Mode: AC80

Packet Size: 1000

5725 MHz Band Edge Signal Radiated Field Strength

Frequency	Level	Pol	15.E		Detector	Azimuth	Height	Comments
MHz	dB μ V/m	v/h	Limit	Margin	Pk/QP/Avg	degrees	meters	
5724.280	71.1	V	78.3	-7.2	PK	114	2.2	POS; RB 1 MHz; VB: 3 MHz
5724.640	64.7	H	78.3	-13.6	PK	109	1.8	POS; RB 1 MHz; VB: 3 MHz

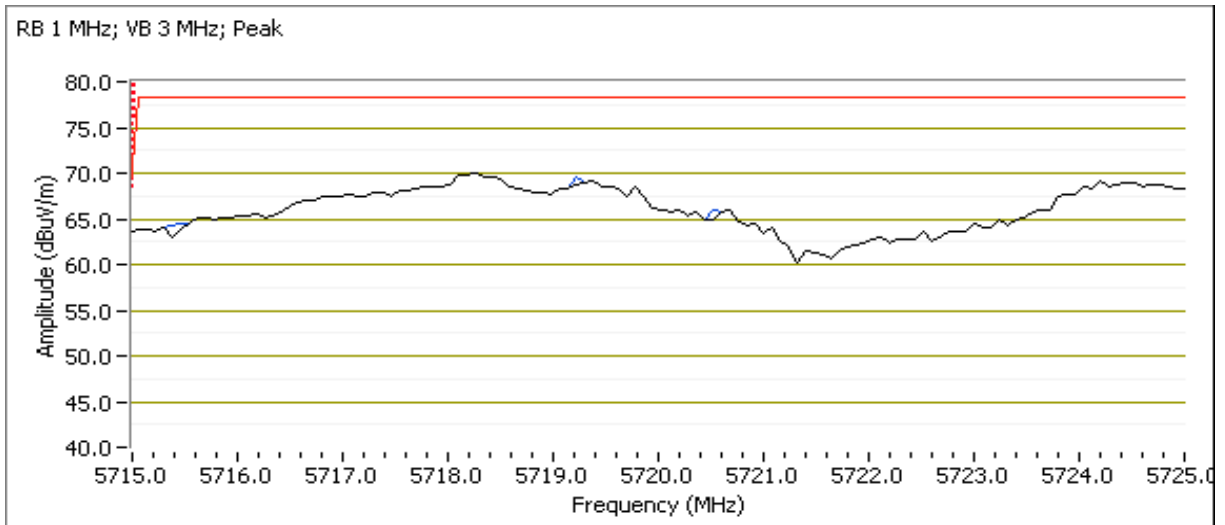



EMC Test Data

Client: Vivint Wireless	Job Number: J96091
Model: 1520 (4x4 5GHz 802.11 Client)	T-Log Number: T96173
	Project Manager: Irene Rademacher
Contact: Venkat Kalkunte	Project Coordinator: -
Standard: FCC 15.B / 15.407 (New Rules)	Class: N/A

5715 MHz Band Edge Signal Radiated Field Strength

Frequency MHz	Level dB μ V/m	Pol v/h	15.E		Detector Pk/QP/Avg	Azimuth degrees	Height meters	Comments
			Limit	Margin				
5704.960	60.7	V	68.3	-7.6	PK	114	2.2	POS; RB 1 MHz; VB: 3 MHz
5714.820	58.6	H	68.3	-9.7	PK	109	1.8	POS; RB 1 MHz; VB: 3 MHz





EMC Test Data

Client: Vivint Wireless	Job Number: J96091
Model: 1520 (4x4 5GHz 802.11 Client)	T-Log Number: T96173
	Project Manager: Irene Rademacher
Contact: Venkat Kalkunte	Project Coordinator: -
Standard: FCC 15.B / 15.407 (New Rules)	Class: N/A

Date of Test: 12/10/14
 Test Engineer: M. Birgani

Test Location: Chamber #4
 EUT Voltage: POE

Channel: 155 - 5775MHz
 Tx Chain: 4Tx
 Mode: AC80

Power Setting: 14
 Data Rate: MCS 8
 Packet Size: 1000

5850 MHz Band Edge Signal Radiated Field Strength

Frequency MHz	Level dB μ V/m	Pol v/h	15.E		Detector PK/QP/Avg	Azimuth degrees	Height meters	Comments
			Limit	Margin				
5858.340	63.8	V	78.3	-14.5	PK	114	2.2	POS; RB 1 MHz; VB: 3 MHz
5859.480	58.2	H	78.3	-20.1	PK	109	1.8	POS; RB 1 MHz; VB: 3 MHz

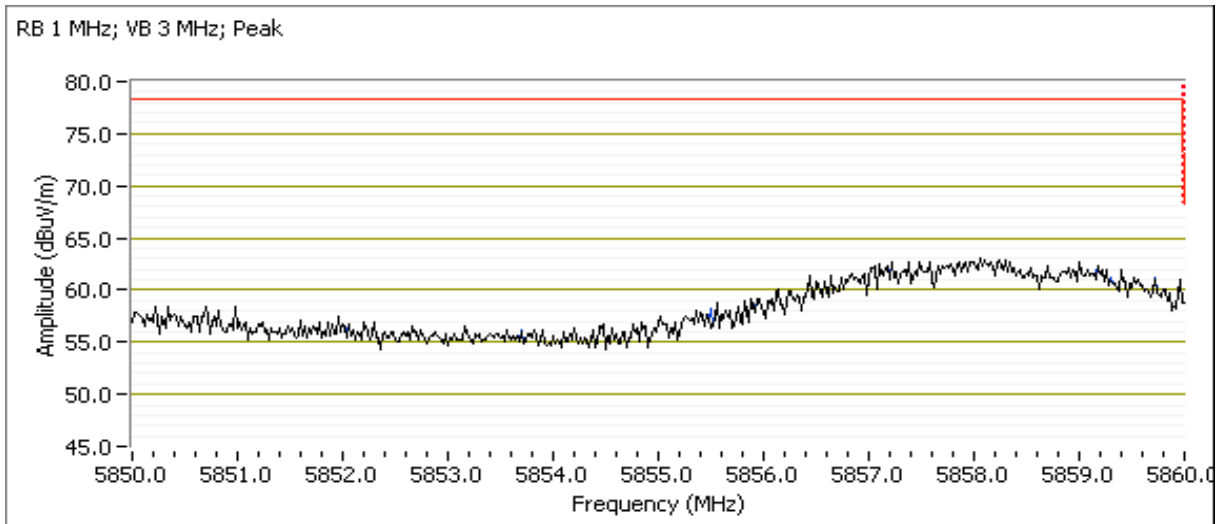



EMC Test Data

Client: Vivint Wireless	Job Number: J96091
Model: 1520 (4x4 5GHz 802.11 Client)	T-Log Number: T96173
	Project Manager: Irene Rademacher
Contact: Venkat Kalkunte	Project Coordinator: -
Standard: FCC 15.B / 15.407 (New Rules)	Class: N/A

5860 MHz Band Edge Signal Radiated Field Strength

Frequency MHz	Level dB μ V/m	Pol v/h	15.E		Detector Pk/QP/Avg	Azimuth degrees	Height meters	Comments
			Limit	Margin				
5866.310	66.7	V	68.3	-1.6	PK	114	2.2	POS; RB 1 MHz; VB: 3 MHz
5865.770	62.3	H	68.3	-6.0	PK	109	1.8	POS; RB 1 MHz; VB: 3 MHz





EMC Test Data

Client: Vivint Wireless	Job Number: J96091
Model: 1520 (4x4 5GHz 802.11 Client)	T-Log Number: T96173
	Project Manager: Irene Rademacher
Contact: Venkat Kalkunte	Project Coordinator: -
Standard: FCC 15.B / 15.407 (New Rules)	Class: N/A

RSS 210 and FCC 15.407 (UNII) Radiated Spurious Emissions

Test Specific Details

Objective: The objective of this test session is to perform final qualification testing of the EUT with respect to the specification listed above.

General Test Configuration

The EUT and all local support equipment were located on the turntable for radiated spurious emissions testing. For radiated emissions testing the measurement antenna was located 3 meters from the EUT, unless otherwise noted.

Ambient Conditions:

Temperature: 21.5 °C
Rel. Humidity: 42 %

Summary of Results

Run #	Mode	Channel	Target Power Setting	Passing Power Setting	Test Performed	Limit	Result / Margin
Scans on "center" channel for all four OFDM modes to determine the worst case mode.							
1	n20	40 - 5200MHz	21	21	Radiated Emissions, 1 - 40 GHz	FCC 15.209 / 15 E	53.3 dBµV/m @ 20800.0 MHz (-0.7 dB)
	n40	38 - 5190MHz	21	21	Radiated Emissions, 1 - 40 GHz	FCC 15.209 / 15 E	52.2 dBµV/m @ 20760.2 MHz (-1.8 dB)
Measurements on low and high channels in worst-case OFDM mode.							
2	n20	36 - 5180MHz	21	21	Radiated Emissions, 1 - 40 GHz	FCC 15.209 / 15 E	51.8 dBµV/m @ 20720.2 MHz (-2.2 dB)
	n20	48 - 5240MHz	21	21	Radiated Emissions, 1 - 40 GHz	FCC 15.209 / 15 E	50.9 dBµV/m @ 20960.1 MHz (-3.1 dB)



EMC Test Data

Client: Vivint Wireless	Job Number: J96091
Model: 1520 (4x4 5GHz 802.11 Client)	T-Log Number: T96173
	Project Manager: Irene Rademacher
Contact: Venkat Kalkunte	Project Coordinator: -
Standard: FCC 15.B / 15.407 (New Rules)	Class: N/A

Run #	Mode	Channel	Target Power Setting	Passing Power Setting	Test Performed	Limit	Result / Margin
Scans on "center" channel for all OFDM modes to determine the worst case mode.							
3	n20	60 - 5300MHz	21	17	Radiated Emissions, 1 - 40 GHz	FCC 15.209 / 15 E	53.7 dBµV/m @ 10600.1 MHz (-0.3 dB)
	n40	54 - 5270MHz	21	21	Radiated Emissions, 1 - 40 GHz	FCC 15.209 / 15 E	67.4 dBµV/m @ 10538.8 MHz (-0.9 dB)
Measurements on low and high channels in worst-case OFDM mode.							
4	n20	52 - 5260MHz	21	21	Radiated Emissions, 1 - 40 GHz	FCC 15.209 / 15 E	65.1 dBµV/m @ 10520.8 MHz (-3.2 dB)
	n20	64 - 5320MHz	21	19	Radiated Emissions, 1 - 40 GHz	FCC 15.209 / 15 E	52.7 dBµV/m @ 10640.2 MHz (-1.3 dB)
Scans on "center" channel for all OFDM modes to determine the worst case mode.							
5	n20	116 - 5580MHz	21	21	Radiated Emissions, 1 - 40 GHz	FCC 15.209 / 15 E	52.7 dBµV/m @ 22320.2 MHz (-1.3 dB)
	n40	110 - 5550MHz	21	21	Radiated Emissions, 1 - 40 GHz	FCC 15.209 / 15 E	53.1 dBµV/m @ 22200.1 MHz (-0.9 dB)
Measurements on low and high channels in worst-case OFDM mode.							
6	n40	102 - 5510MHz	21	21	Radiated Emissions, 1 - 40 GHz	FCC 15.209 / 15 E	51.1 dBµV/m @ 22040.3 MHz (-2.9 dB)
	n40	142 - 5710MHz	21	21	Radiated Emissions, 1 - 40 GHz	FCC 15.209 / 15 E	53.3 dBµV/m @ 22840.2 MHz (-0.7 dB)
Scans on "center" channel for all OFDM modes to determine the worst case mode.							
7	n20	157 - 5785MHz	21	20	Radiated Emissions, 1 - 40 GHz	FCC 15.209 / 15 E	53.9 dBµV/m @ 11569.9 MHz (-0.1 dB)
	n40	159 - 5795MHz	21	20	Radiated Emissions, 1 - 40 GHz	FCC 15.209 / 15 E	53.5 dBµV/m @ 11590.1 MHz (-0.5 dB)
Measurements on low and high channels in worst-case OFDM mode.							
8	n20	149 - 5745MHz	21	21	Radiated Emissions, 1 - 40 GHz	FCC 15.209 / 15 E	53.7 dBµV/m @ 11490.1 MHz (-0.3 dB)
	n20	165 - 5825MHz	21	20	Radiated Emissions, 1 - 40 GHz	FCC 15.209 / 15 E	52.8 dBµV/m @ 11649.9 MHz (-1.2 dB)

Client: Vivint Wireless	Job Number: J96091
Model: 1520 (4x4 5GHz 802.11 Client)	T-Log Number: T96173
	Project Manager: Irene Rademacher
Contact: Venkat Kalkunte	Project Coordinator: -
Standard: FCC 15.B / 15.407 (New Rules)	Class: N/A

Modifications Made During Testing

No modifications were made to the EUT during testing

Deviations From The Standard

No deviations were made from the requirements of the standard.

Procedure Comments:

Measurements performed in accordance with FCC KDB 789033

Peak measurements performed with: RBW=1MHz, VBW=3MHz, peak detector, max hold, auto sweep time

Unless otherwise stated/noted, emission has duty cycle $\geq 98\%$ and was measured using RBW=1MHz, VBW=10Hz, peak detector, linear average mode, auto sweep time, max hold.

Preliminary testing showed no radio related emissions below 1GHz

Testing below 1GHz was performed with the EUT at 1.5m height. C63.10 does not specify the height for floor standing products and the 1.5m height was considered more representative of the final end use installation.

Mode	Data Rate	Duty Cycle (x)	Constant DC?	T (ms)	Pwr Cor Factor*	Lin Volt Cor Factor**	Min VBW for FS (Hz)
n20	6.5	96.5%	yes	2.54	0.16	0.31	394
n40	13.5	94.3%	yes	1.27	0.26	0.51	787

Sample Notes

Sample S/N: Prototype

Driver: -

Antenna: 6dBi

Measurement Specific Notes:

Note 1:	For emissions outside of the restricted bands the limit is -27dBm/MHz eirp (68.3dBuV/m). The measurement method required is a peak measurement (RB=1MHz, VB \geq 3MHz, peak detector). Per KDB 789033 2) c) (i), compliance can be demonstrated by meeting the average and peak limits of 15.209, as an alternative.
Note 2:	Emission has duty cycle $\geq 98\%$, average measurement performed: RBW=1MHz, VBW=3MHz, RMS, Power averaging, auto sweep, trace average 100 traces
Note 3:	Emission has duty cycle $< 98\%$, but constant, average measurement performed: RBW=1MHz, VBW=10Hz, peak detector, linear averaging, auto sweep, trace average $100 * 1/DC$ traces, measurement corrected by Linear Voltage correction factor
Note 5:	Emission has duty cycle $< 98\%$, but constant, average measurement performed: RBW=1MHz, VBW=3MHz, RMS, Power averaging, auto sweep, trace average $100 * 1/DC$ traces, measurement corrected by Pwr correction factor
Note 6:	Plots of the average and peak bandedge do not account for any duty cycle correction. Refer to the tabluar results for final measurements.



EMC Test Data

Client: Vivint Wireless	Job Number: J96091
Model: 1520 (4x4 5GHz 802.11 Client)	T-Log Number: T96173
	Project Manager: Irene Rademacher
Contact: Venkat Kalkunte	Project Coordinator: -
Standard: FCC 15.B / 15.407 (New Rules)	Class: N/A

Run #1, Radiated Spurious Emissions, 1,000 - 40,000 MHz. Operation in the 5150-5250 MHz Band

Date of Test: 10/28/14, 10/30/14, 10/31/14 Config. Used: 1
 Test Engineer: Jack Liu / Rafael Varelas Config Change: -
 Test Location: FT Chamber# 4 EUT Voltage: PoE

Run #1a: Center Channel

Channel: 40 Mode: 11n20
 Tx Chain: 4x4 Data Rate: MCS8

Frequency MHz	Level dB μ V/m	Pol v/h	15.209 / 15E		Detector Pk/QP/Avg	Azimuth degrees	Height meters	Comments
			Limit	Margin				
20800.040	53.3	H	54.0	-0.7	AVG	125	1.8	Note3;RB 1 MHz;VB 10 Hz;Peak
20800.100	59.9	H	74.0	-14.1	PK	125	1.8	RB 1 MHz;VB 3 MHz;Peak
10399.130	64.9	H	68.3	-3.4	PK	35	1.9	RB 1 MHz;VB 3 MHz;Peak
1000.050	42.9	H	54.0	-11.1	AVG	37	1.0	RB 1 MHz;VB 10 Hz;Peak
1000.050	48.4	H	74.0	-25.6	PK	37	1.0	RB 1 MHz;VB 3 MHz;Peak
1125.020	42.8	H	54.0	-11.2	AVG	47	1.2	RB 1 MHz;VB 10 Hz;Peak
1125.100	48.1	H	74.0	-25.9	PK	47	1.2	RB 1 MHz;VB 3 MHz;Peak
6933.480	56.6	V	68.3	-11.7	PK	245	1.7	RB 1 MHz;VB 3 MHz;Peak
4840.130	42.1	V	54.0	-11.9	AVG	252	1.9	RB 1 MHz;VB 10 Hz;Peak
4868.000	54.0	V	74.0	-20.0	PK	252	1.9	RB 1 MHz;VB 3 MHz;Peak
5522.800	57.5	V	68.3	-10.8	PK	259	2.0	RB 1 MHz;VB 3 MHz;Peak
15600.070	49.3	H	54.0	-4.7	AVG	21	1.9	Note3;RB 1 MHz;VB 10 Hz;Peak
15596.130	63.0	H	74.0	-11.0	PK	21	1.9	RB 1 MHz;VB 3 MHz;Peak
20800.040	49.9	V	54.0	-4.1	AVG	75	1.7	Note3;RB 1 MHz;VB 10 Hz;Peak
20800.410	59.3	V	74.0	-14.7	PK	75	1.7	RB 1 MHz;VB 3 MHz;Peak

- Note: Preliminary Scans made between 18 - 40 GHz with the measurement antenna moved around the card and its antennas 20-50cm from the device. Plot not included.
- Note 1: For emissions in restricted bands, the limit of 15.209 was used which requires average and peak measurements.
- Note 2: For emissions outside of the restricted bands the limit is -27dBm/MHz eirp (68.3dBuV/m). The measurement method required is a peak measurement (RB=1MHz, VB \geq 3MHz, peak detector).

Client: Vivint Wireless	Job Number: J96091
Model: 1520 (4x4 5GHz 802.11 Client)	T-Log Number: T96173
	Project Manager: Irene Rademacher
Contact: Venkat Kalkunte	Project Coordinator: -
Standard: FCC 15.B / 15.407 (New Rules)	Class: N/A

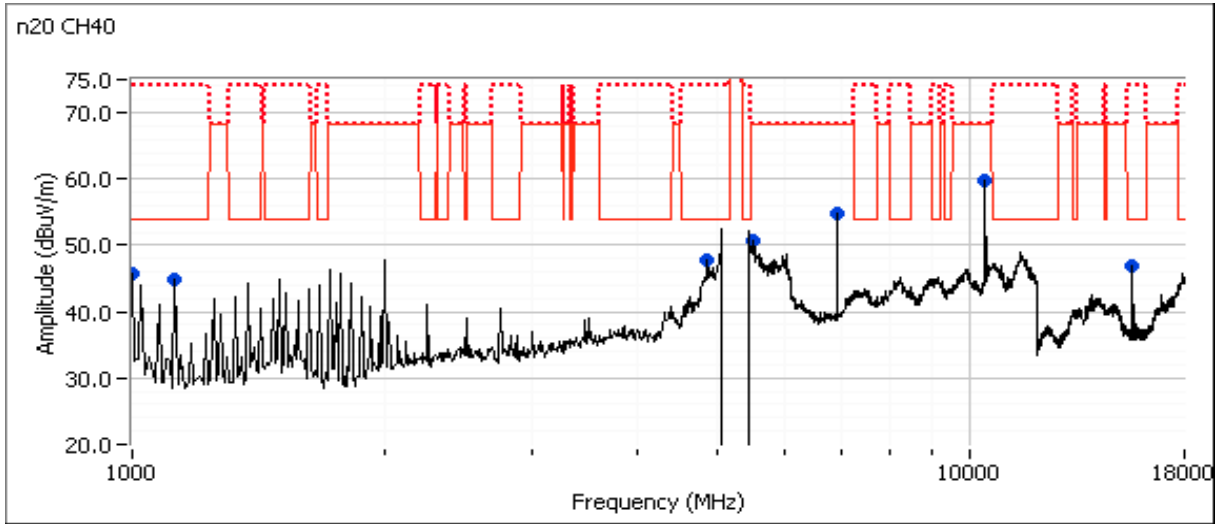



EMC Test Data

Client: Vivint Wireless	Job Number: J96091
Model: 1520 (4x4 5GHz 802.11 Client)	T-Log Number: T96173
	Project Manager: Irene Rademacher
Contact: Venkat Kalkunte	Project Coordinator: -
Standard: FCC 15.B / 15.407 (New Rules)	Class: N/A

Run #1b: Center Channel

Channel: 38 Mode: 11n40
 Tx Chain: 4x4 Data Rate: MCS8

Frequency MHz	Level dB μ V/m	Pol v/h	15.209 / 15E		Detector Pk/QP/Avg	Azimuth degrees	Height meters	Comments
			Limit	Margin				
20760.190	52.2	H	54.0	-1.8	AVG	125	1.7	Note3;RB 1 MHz;VB 10 Hz;Peak
20760.120	59.4	H	74.0	-14.6	PK	125	1.7	RB 1 MHz;VB 3 MHz;Peak
10384.470	63.9	H	68.3	-4.4	PK	44	2.4	RB 1 MHz;VB 3 MHz;Peak
1125.030	42.6	H	54.0	-11.4	AVG	42	1.2	RB 1 MHz;VB 10 Hz;Peak
1125.230	48.0	H	74.0	-26.0	PK	42	1.2	RB 1 MHz;VB 3 MHz;Peak
1000.050	42.6	H	54.0	-11.4	AVG	41	1.0	RB 1 MHz;VB 10 Hz;Peak
1000.220	48.3	H	74.0	-25.7	PK	41	1.0	RB 1 MHz;VB 3 MHz;Peak
1674.970	41.4	H	54.0	-12.6	AVG	117	1.2	RB 1 MHz;VB 10 Hz;Peak
1674.900	47.4	H	74.0	-26.6	PK	117	1.2	RB 1 MHz;VB 3 MHz;Peak
2000.010	50.8	H	68.3	-17.5	PK	144	1.8	RB 1 MHz;VB 3 MHz;Peak
6920.050	57.6	V	68.3	-10.7	PK	245	1.6	RB 1 MHz;VB 3 MHz;Peak
15582.070	44.2	H	54.0	-9.8	AVG	18	1.8	Note3;RB 1 MHz;VB 10 Hz;Peak
15581.730	57.4	H	74.0	-16.6	PK	18	1.8	RB 1 MHz;VB 3 MHz;Peak
20760.170	48.8	V	54.0	-5.2	AVG	76	1.8	Note3;RB 1 MHz;VB 10 Hz;Peak
20760.370	59.6	V	74.0	-14.4	PK	76	1.8	RB 1 MHz;VB 3 MHz;Peak

- Note: Preliminary Scans made between 18 - 40 GHz with the measurement antenna moved around the card and its antennas 20-50cm from the device. Plot not included.
- Note 1: For emissions in restricted bands, the limit of 15.209 was used which requires average and peak measurements.
- Note 2: For emissions outside of the restricted bands the limit is -27dBm/MHz eirp (68.3dBuV/m). The measurement method required is a peak measurement (RB=1MHz, VB \geq 3MHz, peak detector).

Client: Vivint Wireless	Job Number: J96091
Model: 1520 (4x4 5GHz 802.11 Client)	T-Log Number: T96173
	Project Manager: Irene Rademacher
Contact: Venkat Kalkunte	Project Coordinator: -
Standard: FCC 15.B / 15.407 (New Rules)	Class: N/A

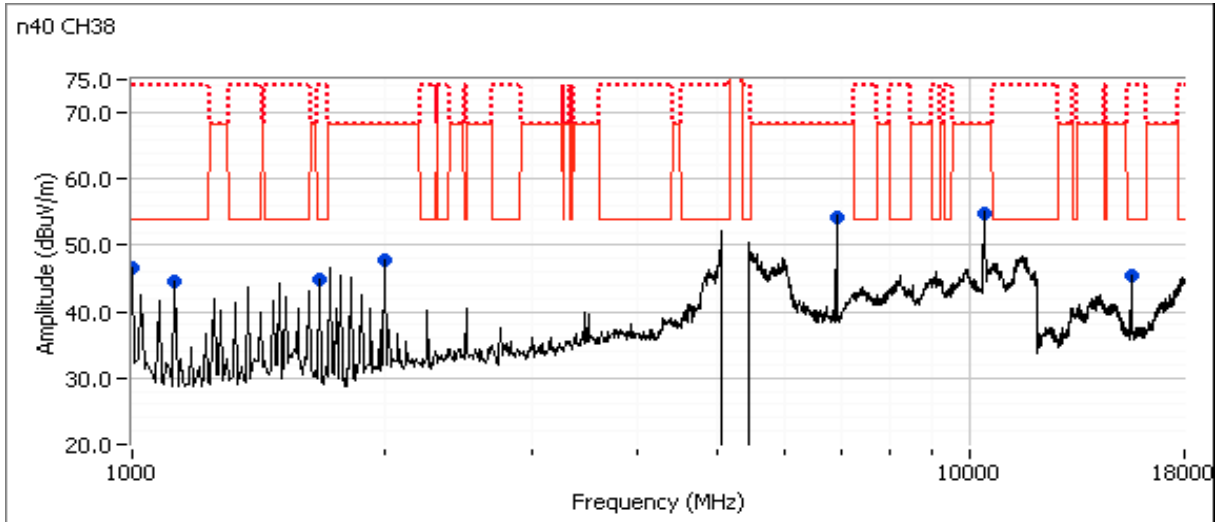



EMC Test Data

Client: Vivint Wireless	Job Number: J96091
Model: 1520 (4x4 5GHz 802.11 Client)	T-Log Number: T96173
	Project Manager: Irene Rademacher
Contact: Venkat Kalkunte	Project Coordinator: -
Standard: FCC 15.B / 15.407 (New Rules)	Class: N/A

Run #2: Radiated Spurious Emissions, 1,000 - 40000 MHz. Operating Mode: Worse case from Run #1
 Date of Test: 10/29/14, 10/30/14, 10/31/14 Config. Used: 1
 Test Engineer: Rafael Varelas / Jack Liu Config Change: -
 Test Location: FT Chamber# 4 EUT Voltage: PoE

Run #2a: Low Channel

Channel: 36 Mode: 11n20
 Tx Chain: 4x4 Data Rate: MCS8

Frequency MHz	Level dBµV/m	Pol v/h	15.209 / 15.247		Detector Pk/QP/Avg	Azimuth degrees	Height meters	Comments
			Limit	Margin				
20720.170	51.8	H	54.0	-2.2	AVG	126	1.7	Note 3, RB 1 MHz;VB 10 Hz;Peak
20720.080	59.9	H	74.0	-14.1	PK	126	1.7	RB 1 MHz;VB 3 MHz;Peak
10361.590	61.9	H	68.3	-6.4	PK	56	1.2	RB 1 MHz;VB 3 MHz;Peak
1125.010	43.1	H	54.0	-10.9	AVG	39	1.2	RB 1 MHz;VB 10 Hz;Peak
1125.120	48.1	H	74.0	-25.9	PK	39	1.2	RB 1 MHz;VB 3 MHz;Peak
1000.010	42.5	H	54.0	-11.5	AVG	68	1.0	RB 1 MHz;VB 10 Hz;Peak
1000.040	47.9	H	74.0	-26.1	PK	68	1.0	RB 1 MHz;VB 3 MHz;Peak
1675.010	40.9	H	54.0	-13.1	AVG	106	1.0	RB 1 MHz;VB 10 Hz;Peak
1675.050	46.5	H	74.0	-27.5	PK	106	1.0	RB 1 MHz;VB 3 MHz;Peak
6906.760	55.9	V	68.3	-12.4	PK	246	1.2	RB 1 MHz;VB 3 MHz;Peak
15540.130	44.3	H	54.0	-9.7	AVG	136	1.0	RB 1 MHz;VB 10 Hz;Peak
15539.800	55.0	H	74.0	-19.0	PK	136	1.0	RB 1 MHz;VB 3 MHz;Peak
15543.730	46.7	V	54.0	-7.3	AVG	94	2.0	Note 3, RB 1 MHz;VB 10 Hz;Peak
15538.930	57.6	V	74.0	-16.4	PK	94	2.0	RB 1 MHz;VB 3 MHz;Peak
20720.170	48.8	V	54.0	-5.2	AVG	74	1.7	Note 3, RB 1 MHz;VB 10 Hz;Peak
20720.250	58.8	V	74.0	-15.2	PK	74	1.7	RB 1 MHz;VB 3 MHz;Peak

Note: Preliminary Scans made between 18 - 40 GHz with the measurement antenna moved around the card and its antennas 20-50cm from the device. Plot not included.

Client: Vivint Wireless	Job Number: J96091
Model: 1520 (4x4 5GHz 802.11 Client)	T-Log Number: T96173
	Project Manager: Irene Rademacher
Contact: Venkat Kalkunte	Project Coordinator: -
Standard: FCC 15.B / 15.407 (New Rules)	Class: N/A

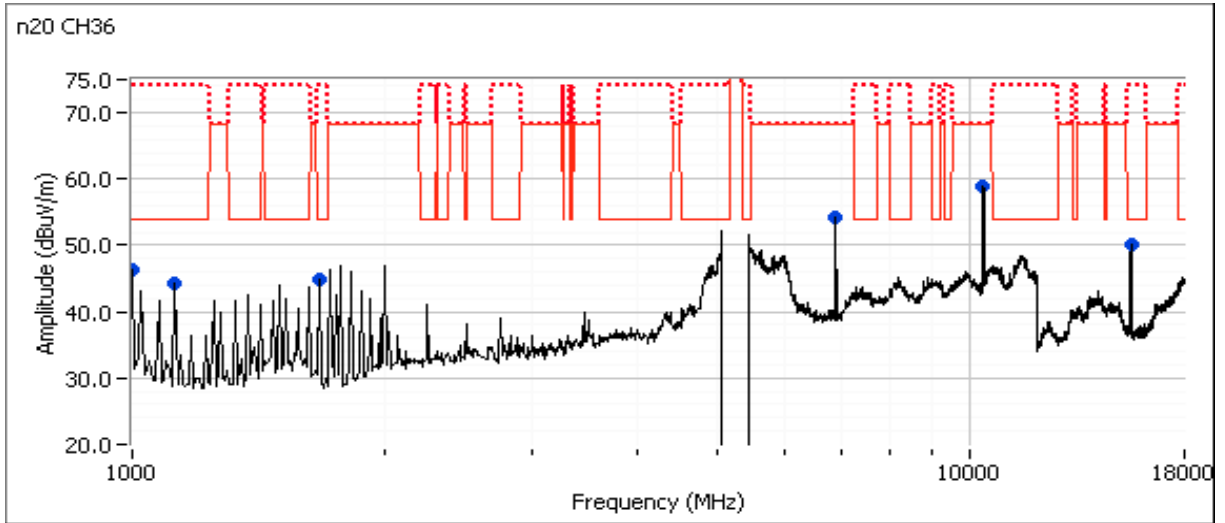



EMC Test Data

Client: Vivint Wireless	Job Number: J96091
Model: 1520 (4x4 5GHz 802.11 Client)	T-Log Number: T96173
	Project Manager: Irene Rademacher
Contact: Venkat Kalkunte	Project Coordinator: -
Standard: FCC 15.B / 15.407 (New Rules)	Class: N/A

Run #2b: High Channel

Channel: 48 Mode: 11n20
 Tx Chain: 4x4 Data Rate: MCS8

Frequency MHz	Level dB μ V/m	Pol v/h	15.209 / 15.247		Detector PK/QP/Avg	Azimuth degrees	Height meters	Comments
			Limit	Margin				
20960.140	50.9	H	54.0	-3.1	AVG	132	1.9	Note 3, RB 1 MHz;VB 10 Hz;Peak
20960.100	59.1	H	74.0	-14.9	PK	132	1.9	RB 1 MHz;VB 3 MHz;Peak
10480.270	64.7	H	68.3	-3.6	PK	56	1.4	RB 1 MHz;VB 3 MHz;Peak
1000.010	42.3	H	54.0	-11.7	AVG	33	1.0	RB 1 MHz;VB 3 MHz;Peak
1000.020	46.0	H	74.0	-28.0	PK	33	1.0	RB 1 MHz;VB 10 Hz;Peak
1125.010	41.0	H	54.0	-13.0	AVG	37	2.0	RB 1 MHz;VB 10 Hz;Peak
1125.060	46.5	H	74.0	-27.5	PK	37	2.0	RB 1 MHz;VB 3 MHz;Peak
6986.890	54.9	V	68.3	-13.4	PK	241	1.7	RB 1 MHz;VB 3 MHz;Peak
5440.170	48.5	V	54.0	-5.5	AVG	251	2.2	Note 3, RB 1 MHz;VB 10 Hz;Peak
5443.170	59.1	V	74.0	-14.9	PK	251	2.2	RB 1 MHz;VB 3 MHz;Peak
15720.200	44.7	H	54.0	-9.3	AVG	97	2.1	RB 1 MHz;VB 10 Hz;Peak
15736.330	55.7	H	74.0	-18.3	PK	97	2.1	RB 1 MHz;VB 3 MHz;Peak
15720.670	48.0	V	54.0	-6.0	AVG	93	1.8	Note 3, RB 1 MHz;VB 10 Hz;Peak
15716.000	60.0	V	74.0	-14.0	PK	93	1.8	RB 1 MHz;VB 3 MHz;Peak
20960.190	47.6	V	54.0	-6.4	AVG	75	1.7	Note 3, RB 1 MHz;VB 10 Hz;Peak
20960.180	58.3	V	74.0	-15.7	PK	75	1.7	RB 1 MHz;VB 3 MHz;Peak

Note: Preliminary Scans made between 18 - 40 GHz with the measurement antenna moved around the card and its antennas 20-50cm from the device. Plot not included.

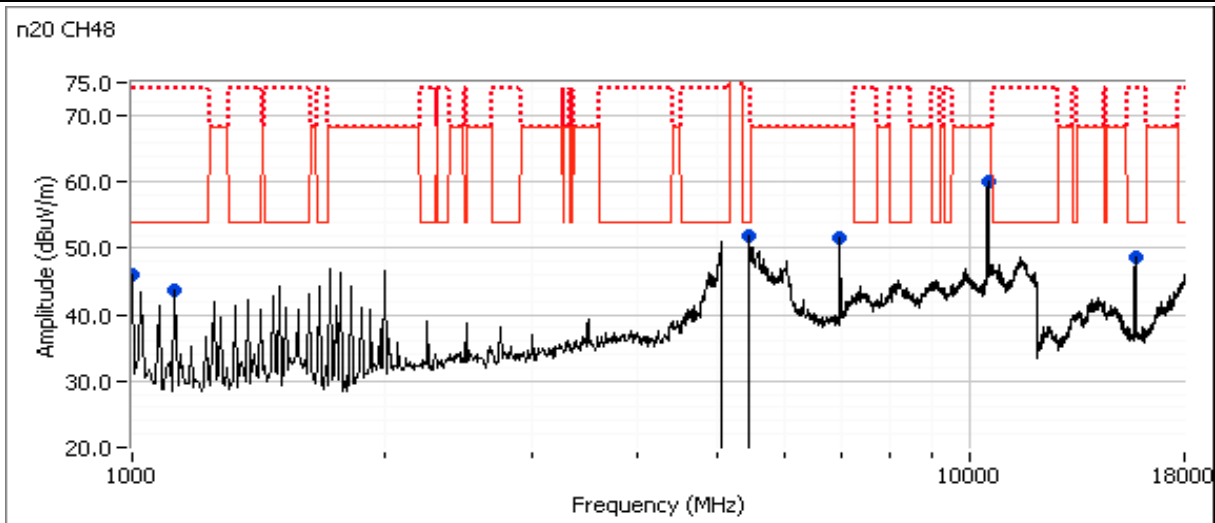



EMC Test Data

Client: Vivint Wireless	Job Number: J96091
Model: 1520 (4x4 5GHz 802.11 Client)	T-Log Number: T96173
	Project Manager: Irene Rademacher
Contact: Venkat Kalkunte	Project Coordinator: -
Standard: FCC 15.B / 15.407 (New Rules)	Class: N/A

Run #3, Radiated Spurious Emissions, 1,000 - 40,000 MHz. Operation in the 5250-5350 MHz Band

Date of Test: 10/28/14, 10/30/14, 10/31/14 Config. Used: 1
 Test Engineer: Jack Liu / Rafael Varelas Config Change: -
 Test Location: FT Chamber# 4 EUT Voltage: PoE

Run #3a: Center Channel

Channel: 60 Mode: 11n20
 Tx Chain: 4x4 Data Rate: MCS8 pre scan is using power setting 21

Frequency	Level	Pol	15.209 / 15E		Detector	Azimuth	Height	Comments
MHz	dB μ V/m	v/h	Limit	Margin	Pk/QP/Avg	degrees	meters	
Power setting : 17								
10600.100	53.7	H	54.0	-0.3	AVG	20	2.3	Note3;RB 1 MHz;VB 10 Hz;Peak
10603.200	66.2	H	74.0	-7.8	PK	20	2.3	RB 1 MHz;VB 3 MHz;Peak
1000.020	42.2	H	54.0	-11.8	AVG	46	1.8	RB 1 MHz;VB 10 Hz;Peak
1000.080	48.1	H	74.0	-25.9	PK	46	1.8	RB 1 MHz;VB 3 MHz;Peak
1500.030	44.0	H	54.0	-10.0	AVG	60	1.9	RB 1 MHz;VB 10 Hz;Peak
1499.930	48.3	H	74.0	-25.7	PK	60	1.9	RB 1 MHz;VB 3 MHz;Peak
1999.930	51.1	H	68.3	-17.2	PK	144	1.9	RB 1 MHz;VB 3 MHz;Peak
7066.830	54.7	V	68.3	-13.6	PK	240	1.8	RB 1 MHz;VB 3 MHz;Peak
15900.200	45.9	H	54.0	-8.1	AVG	117	1.9	Note3;RB 1 MHz;VB 10 Hz;Peak
15904.730	57.9	H	74.0	-16.1	PK	117	1.9	RB 1 MHz;VB 3 MHz;Peak
21200.210	51.7	H	54.0	-2.3	AVG	106	1.7	Note3;RB 1 MHz;VB 10 Hz;Peak
21200.200	60.0	H	74.0	-14.0	PK	106	1.7	RB 1 MHz;VB 3 MHz;Peak
21200.220	47.6	V	54.0	-6.4	AVG	102	1.6	Note3;RB 1 MHz;VB 10 Hz;Peak
21199.880	58.5	V	74.0	-15.5	PK	102	1.6	RB 1 MHz;VB 3 MHz;Peak

- Note: Preliminary Scans made between 18 - 40 GHz with the measurement antenna moved around the card and its antennas 20-50cm from the device. Plot not included.
- Note 1: For emissions in restricted bands, the limit of 15.209 was used which requires average and peak measurements.
- Note 2: For emissions outside of the restricted bands the limit is -27dBm/MHz eirp (68.3dBuV/m). The measurement method required is a peak measurement (RB=1MHz, VB \geq 3MHz, peak detector).

Client: Vivint Wireless	Job Number: J96091
Model: 1520 (4x4 5GHz 802.11 Client)	T-Log Number: T96173
	Project Manager: Irene Rademacher
Contact: Venkat Kalkunte	Project Coordinator: -
Standard: FCC 15.B / 15.407 (New Rules)	Class: N/A

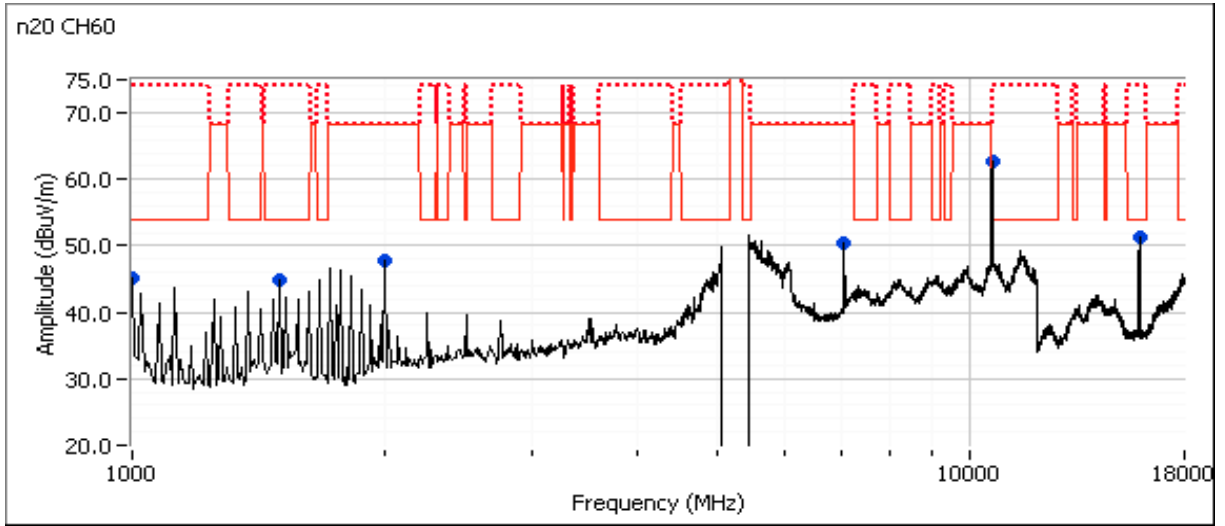



EMC Test Data

Client: Vivint Wireless	Job Number: J96091
Model: 1520 (4x4 5GHz 802.11 Client)	T-Log Number: T96173
	Project Manager: Irene Rademacher
Contact: Venkat Kalkunte	Project Coordinator: -
Standard: FCC 15.B / 15.407 (New Rules)	Class: N/A

Run #3b: Center Channel

Channel: 54 Mode: 11n40
 Tx Chain: 4x4 Data Rate: MCS8

Frequency MHz	Level dB μ V/m	Pol v/h	15.209 / 15E		Detector Pk/QP/Avg	Azimuth degrees	Height meters	Comments
			Limit	Margin				
10538.800	67.4	H	68.3	-0.9	PK	19	2.3	RB 1 MHz;VB 3 MHz;Peak
1000.020	42.4	H	54.0	-11.6	AVG	44	1.5	RB 1 MHz;VB 10 Hz;Peak
1000.130	48.1	H	74.0	-25.9	PK	44	1.5	RB 1 MHz;VB 3 MHz;Peak
1125.030	42.7	H	54.0	-11.3	AVG	48	1.2	RB 1 MHz;VB 10 Hz;Peak
1125.100	48.2	H	74.0	-25.8	PK	48	1.2	RB 1 MHz;VB 3 MHz;Peak
1675.030	40.6	H	54.0	-13.4	AVG	107	1.2	RB 1 MHz;VB 10 Hz;Peak
1675.030	47.1	H	74.0	-26.9	PK	107	1.2	RB 1 MHz;VB 3 MHz;Peak
2000.050	51.1	H	68.3	-17.2	PK	148	1.9	RB 1 MHz;VB 3 MHz;Peak
7026.680	55.8	V	68.3	-12.5	PK	247	1.5	RB 1 MHz;VB 3 MHz;Peak
15810.250	45.4	H	54.0	-8.6	AVG	118	1.7	Note3;RB 1 MHz;VB 10 Hz;Peak
15796.670	56.5	H	74.0	-17.5	PK	118	1.7	RB 1 MHz;VB 3 MHz;Peak
21080.240	49.9	H	54.0	-4.1	AVG	114	1.3	Note3;RB 1 MHz;VB 10 Hz;Peak
21080.180	58.3	H	74.0	-15.7	PK	114	1.3	RB 1 MHz;VB 3 MHz;Peak
21080.200	46.9	V	54.0	-7.1	AVG	103	1.8	Note3;RB 1 MHz;VB 10 Hz;Peak
21080.800	57.6	V	74.0	-16.4	PK	103	1.8	RB 1 MHz;VB 3 MHz;Peak

Note: Preliminary Scans made between 18 - 40 GHz with the measurement antenna moved around the card and its antennas 20-50cm from the device. Plot not included.

Note 1: For emissions in restricted bands, the limit of 15.209 was used which requires average and peak measurements.

Note 2: For emissions outside of the restricted bands the limit is -27dBm/MHz eirp (68.3dBuV/m). The measurement method required is a peak measurement (RB=1MHz, VB \geq 3MHz, peak detector).

Client: Vivint Wireless	Job Number: J96091
Model: 1520 (4x4 5GHz 802.11 Client)	T-Log Number: T96173
	Project Manager: Irene Rademacher
Contact: Venkat Kalkunte	Project Coordinator: -
Standard: FCC 15.B / 15.407 (New Rules)	Class: N/A

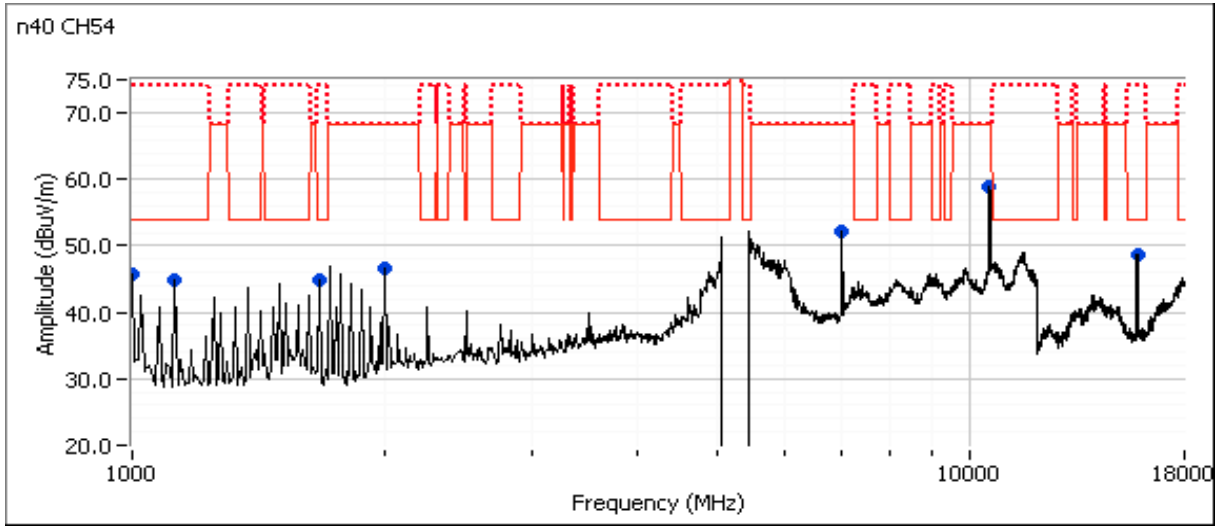



EMC Test Data

Client: Vivint Wireless	Job Number: J96091
Model: 1520 (4x4 5GHz 802.11 Client)	T-Log Number: T96173
	Project Manager: Irene Rademacher
Contact: Venkat Kalkunte	Project Coordinator: -
Standard: FCC 15.B / 15.407 (New Rules)	Class: N/A

Run #4: Radiated Spurious Emissions, 1,000 - 40000 MHz. Operating Mode: Worse case from Run #3
 Date of Test: 10/29/14, 10/30/14 Config. Used: 1
 Test Engineer: Rafael Varelas/Jack Liu Config Change: -
 Test Location: FT Chamber# 4 EUT Voltage: PoE

Run #4a: Low Channel

Channel: 52 Mode: 11n20
 Tx Chain: 4x4 Data Rate: MCS8

Frequency MHz	Level dB μ V/m	Pol v/h	15.209 / 15.247		Detector Pk/QP/Avg	Azimuth degrees	Height meters	Comments
			Limit	Margin				
10520.780	65.1	H	68.3	-3.2	PK	56	1.2	RB 1 MHz;VB 3 MHz;Peak
999.995	42.6	H	54.0	-11.4	AVG	33	1.0	RB 1 MHz;VB 10 Hz;Peak
1000.160	47.7	H	74.0	-26.3	PK	33	1.0	RB 1 MHz;VB 3 MHz;Peak
1124.990	42.7	H	54.0	-11.3	AVG	40	1.2	RB 1 MHz;VB 10 Hz;Peak
1125.070	47.9	H	74.0	-26.1	PK	40	1.2	RB 1 MHz;VB 3 MHz;Peak
7013.470	54.6	V	68.3	-13.7	PK	242	1.1	RB 1 MHz;VB 3 MHz;Peak
5439.990	48.9	V	54.0	-5.1	AVG	254	1.8	Note 3, RB 1 MHz;VB 10 Hz;Peak
5443.730	59.4	V	74.0	-14.6	PK	254	1.8	RB 1 MHz;VB 3 MHz;Peak
15780.130	45.7	H	54.0	-8.3	AVG	120	1.6	RB 1 MHz;VB 10 Hz;Peak
15787.200	56.8	H	74.0	-17.2	PK	120	1.6	RB 1 MHz;VB 3 MHz;Peak
15780.670	49.1	V	54.0	-4.9	AVG	94	1.8	Note 3, RB 1 MHz;VB 10 Hz;Peak
15786.400	61.0	V	74.0	-13.0	PK	94	1.8	RB 1 MHz;VB 3 MHz;Peak
21040.230	49.8	H	54.0	-4.2	AVG	114	1.3	Note 3, RB 1 MHz;VB 10 Hz;Peak
21040.370	58.4	H	74.0	-15.6	PK	114	1.3	RB 1 MHz;VB 3 MHz;Peak
21040.220	47.3	V	54.0	-6.7	AVG	102	1.7	Note 3, RB 1 MHz;VB 10 Hz;Peak
21040.220	58.2	V	74.0	-15.8	PK	102	1.7	RB 1 MHz;VB 3 MHz;Peak

Note: Preliminary Scans made between 18 - 40 GHz with the measurement antenna moved around the card and its antennas 20-50cm from the device. Plot not included.

Client: Vivint Wireless	Job Number: J96091
Model: 1520 (4x4 5GHz 802.11 Client)	T-Log Number: T96173
	Project Manager: Irene Rademacher
Contact: Venkat Kalkunte	Project Coordinator: -
Standard: FCC 15.B / 15.407 (New Rules)	Class: N/A

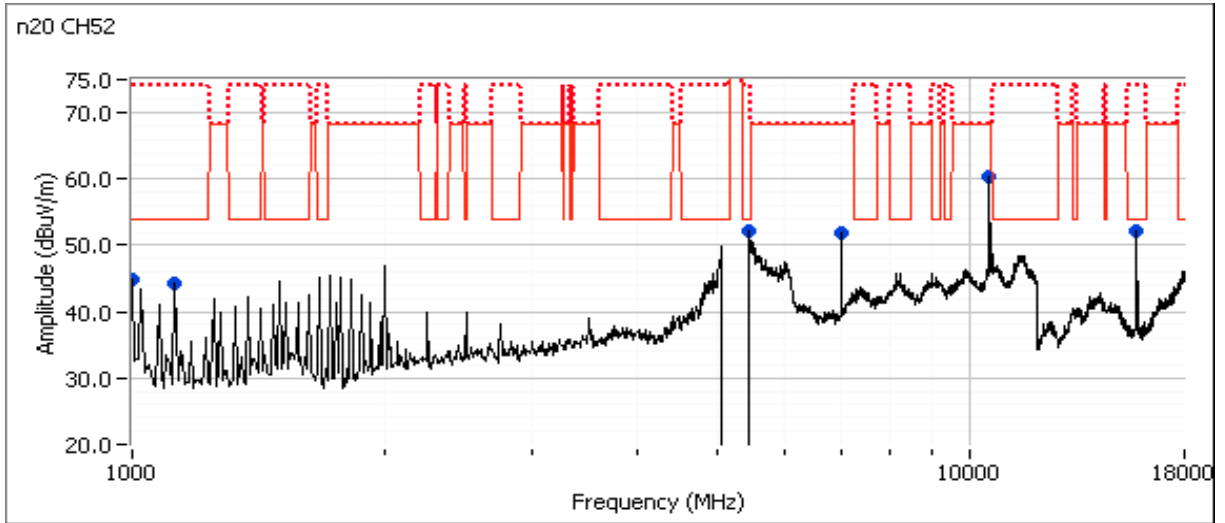



EMC Test Data

Client: Vivint Wireless	Job Number: J96091
Model: 1520 (4x4 5GHz 802.11 Client)	T-Log Number: T96173
	Project Manager: Irene Rademacher
Contact: Venkat Kalkunte	Project Coordinator: -
Standard: FCC 15.B / 15.407 (New Rules)	Class: N/A

Run #4b: High Channel

Channel: 64 Mode: 11n20
 Tx Chain: 4x4 Data Rate: MCS8

Frequency	Level	Pol	15.209 / 15.247		Detector	Azimuth	Height	Comments
MHz	dB μ V/m	v/h	Limit	Margin	PK/QP/Avg	degrees	meters	
Power setting : 19								
10640.200	52.7	H	54.0	-1.3	AVG	113	1.1	Note 3, RB 1 MHz; VB 10 Hz; Peak
10640.260	63.7	H	74.0	-10.3	PK	113	1.1	RB 1 MHz; VB 3 MHz; Peak
1000.030	42.6	H	54.0	-11.4	AVG	35	1.0	RB 1 MHz; VB 10 Hz; Peak
1000.010	47.7	H	74.0	-26.3	PK	35	1.0	RB 1 MHz; VB 3 MHz; Peak
1124.990	42.5	H	54.0	-11.5	AVG	36	1.1	RB 1 MHz; VB 10 Hz; Peak
1125.050	47.8	H	74.0	-26.2	PK	36	1.1	RB 1 MHz; VB 3 MHz; Peak
7093.500	54.2	V	68.3	-14.1	PK	239	1.8	RB 1 MHz; VB 3 MHz; Peak
5440.070	49.9	V	54.0	-4.1	AVG	252	1.5	Note 3, RB 1 MHz; VB 10 Hz; Peak
5447.770	61.0	V	74.0	-13.0	PK	252	1.5	RB 1 MHz; VB 3 MHz; Peak
15960.400	50.1	H	54.0	-3.9	AVG	102	1.7	Note 3, RB 1 MHz; VB 10 Hz; Peak
15957.070	62.2	H	74.0	-11.8	PK	102	1.7	RB 1 MHz; VB 3 MHz; Peak
15957.000	50.4	V	54.0	-3.6	AVG	66	2.0	Note 3, RB 1 MHz; VB 10 Hz; Peak
15966.330	62.1	V	74.0	-11.9	PK	66	2.0	RB 1 MHz; VB 3 MHz; Peak
21280.200	51.0	H	54.0	-3.0	AVG	105	1.7	Note 3, RB 1 MHz; VB 10 Hz; Peak
21280.370	59.7	H	74.0	-14.3	PK	105	1.7	RB 1 MHz; VB 3 MHz; Peak
21280.210	46.6	V	54.0	-7.4	AVG	105	1.5	Note 3, RB 1 MHz; VB 10 Hz; Peak
21279.020	59.1	V	74.0	-14.9	PK	105	1.5	RB 1 MHz; VB 3 MHz; Peak

Note: Preliminary Scans made between 18 - 40 GHz with the measurement antenna moved around the card and its antennas 20-50cm from the device. Plot not included.

Client: Vivint Wireless	Job Number: J96091
Model: 1520 (4x4 5GHz 802.11 Client)	T-Log Number: T96173
	Project Manager: Irene Rademacher
Contact: Venkat Kalkunte	Project Coordinator: -
Standard: FCC 15.B / 15.407 (New Rules)	Class: N/A

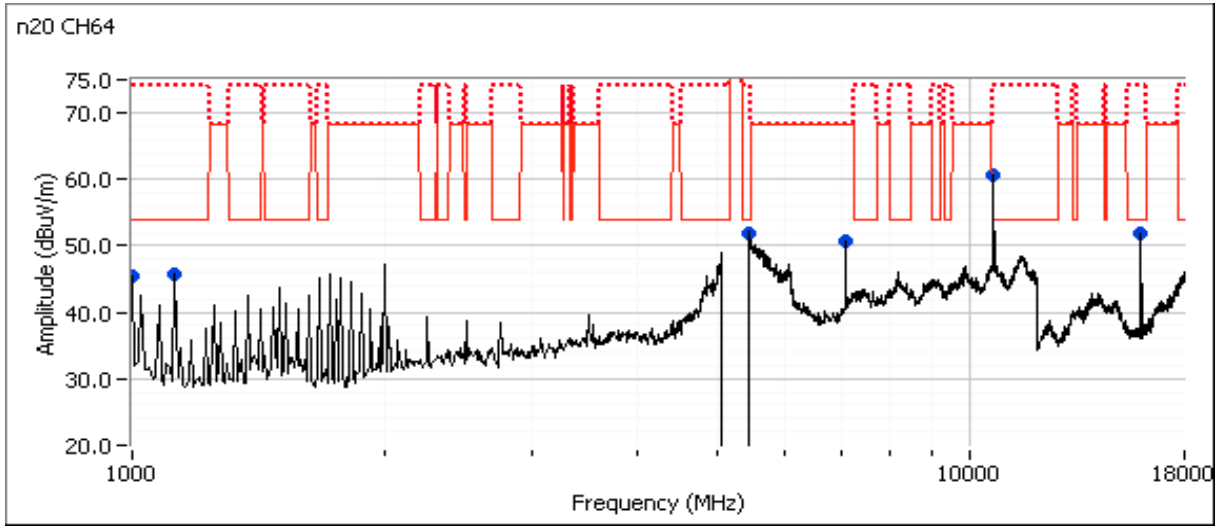



EMC Test Data

Client: Vivint Wireless	Job Number: J96091
Model: 1520 (4x4 5GHz 802.11 Client)	T-Log Number: T96173
	Project Manager: Irene Rademacher
Contact: Venkat Kalkunte	Project Coordinator: -
Standard: FCC 15.B / 15.407 (New Rules)	Class: N/A

Run #5, Radiated Spurious Emissions, 1,000 - 40,000 MHz. Operation in the 5470-5725 MHz Band

Date of Test: 10/29/14, 10/30/14, 10/31/14 Config. Used: 1
 Test Engineer: Jack Liu /Rafael Varelas Config Change: -
 Test Location: FT Chamber# 4 EUT Voltage: PoE

Run #5a: Center Channel

Channel: 116 Mode: 11n20
 Tx Chain: 4x4 Data Rate: MCS8

Frequency MHz	Level dB μ V/m	Pol v/h	15.209 / 15E		Detector Pk/QP/Avg	Azimuth degrees	Height meters	Comments
			Limit	Margin				
22320.180	52.7	H	54.0	-1.3	AVG	151	1.7	Note3; RB 1 MHz;VB 10 Hz;Peak
22320.090	60.3	H	74.0	-13.7	PK	151	1.7	RB 1 MHz;VB 3 MHz;Peak
16743.530	65.7	V	68.3	-2.6	PK	89	1.8	RB 1 MHz;VB 3 MHz;Peak
11160.130	44.7	H	54.0	-9.3	AVG	20	1.5	Note3; RB 1 MHz;VB 10 Hz;Peak
11159.130	56.5	H	74.0	-17.5	PK	20	1.5	RB 1 MHz;VB 3 MHz;Peak
1000.020	42.7	H	54.0	-11.3	AVG	42	1.5	RB 1 MHz;VB 10 Hz;Peak
1000.020	48.3	H	74.0	-25.7	PK	42	1.5	RB 1 MHz;VB 3 MHz;Peak
1125.030	42.1	H	54.0	-11.9	AVG	46	1.1	RB 1 MHz;VB 10 Hz;Peak
1125.070	47.8	H	74.0	-26.2	PK	46	1.1	RB 1 MHz;VB 3 MHz;Peak
1725.070	49.5	H	68.3	-18.8	PK	100	1.1	RB 1 MHz;VB 3 MHz;Peak
2000.080	51.4	H	68.3	-16.9	PK	145	1.8	RB 1 MHz;VB 3 MHz;Peak
3720.020	40.6	H	54.0	-13.4	AVG	140	1.3	RB 1 MHz;VB 10 Hz;Peak
3720.100	47.2	H	74.0	-26.8	PK	140	1.3	RB 1 MHz;VB 3 MHz;Peak
7440.130	45.2	H	54.0	-8.8	AVG	164	1.6	RB 1 MHz;VB 10 Hz;Peak
7439.950	53.9	H	74.0	-20.1	PK	164	1.6	RB 1 MHz;VB 3 MHz;Peak
22320.270	49.4	V	54.0	-4.6	AVG	69	1.8	Note3; RB 1 MHz;VB 10 Hz;Peak
22320.560	58.7	V	74.0	-15.3	PK	69	1.8	RB 1 MHz;VB 3 MHz;Peak

Note: Preliminary Scans made between 18 - 40 GHz with the measurement antenna moved around the card and its antennas 20-50cm from the device. Plot not included.

Note 1: For emissions in restricted bands, the limit of 15.209 was used which requires average and peak measurements.

Note 2: For emissions outside of the restricted bands the limit is -27dBm/MHz eirp (68.3dBuV/m). The measurement method required is a peak measurement (RB=1MHz, VB≥3MHz, peak detector).

Client: Vivint Wireless	Job Number: J96091
Model: 1520 (4x4 5GHz 802.11 Client)	T-Log Number: T96173
	Project Manager: Irene Rademacher
Contact: Venkat Kalkunte	Project Coordinator: -
Standard: FCC 15.B / 15.407 (New Rules)	Class: N/A

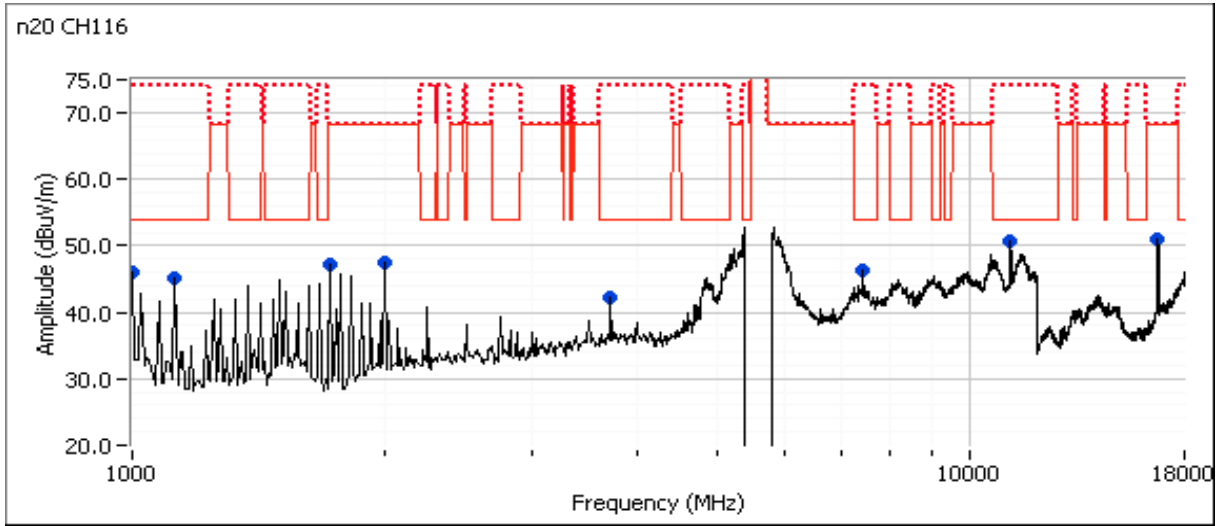



EMC Test Data

Client: Vivint Wireless	Job Number: J96091
Model: 1520 (4x4 5GHz 802.11 Client)	T-Log Number: T96173
	Project Manager: Irene Rademacher
Contact: Venkat Kalkunte	Project Coordinator: -
Standard: FCC 15.B / 15.407 (New Rules)	Class: N/A

Run #5b: Center Channel

Channel: 110 Mode: 11n40
 Tx Chain: 4x4 Data Rate: MCS8

Frequency MHz	Level dB μ V/m	Pol v/h	15.209 / 15E		Detector Pk/QP/Avg	Azimuth degrees	Height meters	Comments
			Limit	Margin				
22200.090	53.1	H	54.0	-0.9	AVG	133	1.7	Note3; RB 1 MHz;VB 10 Hz;Peak
22200.210	60.3	H	74.0	-13.7	PK	133	1.7	RB 1 MHz;VB 3 MHz;Peak
16647.670	63.1	V	68.3	-5.2	PK	102	1.8	RB 1 MHz;VB 3 MHz;Peak
11495.730	44.8	H	54.0	-9.2	AVG	5	1.3	RB 1 MHz;VB 10 Hz;Peak
11483.530	57.3	H	74.0	-16.7	PK	5	1.3	RB 1 MHz;VB 3 MHz;Peak
11109.670	45.4	H	54.0	-8.6	AVG	32	2.5	Note3; RB 1 MHz;VB 10 Hz;Peak
11101.600	58.7	H	74.0	-15.3	PK	32	2.5	RB 1 MHz;VB 3 MHz;Peak
1125.020	42.3	H	54.0	-11.7	AVG	45	1.2	RB 1 MHz;VB 10 Hz;Peak
1125.050	47.9	H	74.0	-26.1	PK	45	1.2	RB 1 MHz;VB 3 MHz;Peak
1000.030	42.0	H	54.0	-12.0	AVG	41	1.5	RB 1 MHz;VB 10 Hz;Peak
999.967	47.6	H	74.0	-26.4	PK	41	1.5	RB 1 MHz;VB 3 MHz;Peak
7400.150	45.3	H	54.0	-8.7	AVG	166	1.8	RB 1 MHz;VB 10 Hz;Peak
7400.180	54.6	H	74.0	-19.4	PK	166	1.8	RB 1 MHz;VB 3 MHz;Peak
2000.070	50.4	H	68.3	-17.9	PK	145	1.8	RB 1 MHz;VB 3 MHz;Peak
3700.030	39.8	H	54.0	-14.2	AVG	221	1.8	RB 1 MHz;VB 10 Hz;Peak
3700.270	46.7	H	74.0	-27.3	PK	221	1.8	RB 1 MHz;VB 3 MHz;Peak
16649.270	60.7	H	68.3	-7.6	PK	49	1.8	RB 1 MHz;VB 3 MHz;Peak
22200.180	51.9	V	54.0	-2.1	AVG	55	1.7	Note3; RB 1 MHz;VB 10 Hz;Peak
22200.010	59.9	V	74.0	-14.1	PK	55	1.7	RB 1 MHz;VB 3 MHz;Peak

- Note: Preliminary Scans made between 18 - 40 GHz with the measurement antenna moved around the card and its antennas 20-50cm from the device. Plot not included.
- Note 1: For emissions in restricted bands, the limit of 15.209 was used which requires average and peak measurements.
- Note 2: For emissions outside of the restricted bands the limit is -27dBm/MHz eirp (68.3dBuV/m). The measurement method required is a peak measurement (RB=1MHz, VB \geq 3MHz, peak detector).

Client: Vivint Wireless	Job Number: J96091
Model: 1520 (4x4 5GHz 802.11 Client)	T-Log Number: T96173
	Project Manager: Irene Rademacher
Contact: Venkat Kalkunte	Project Coordinator: -
Standard: FCC 15.B / 15.407 (New Rules)	Class: N/A

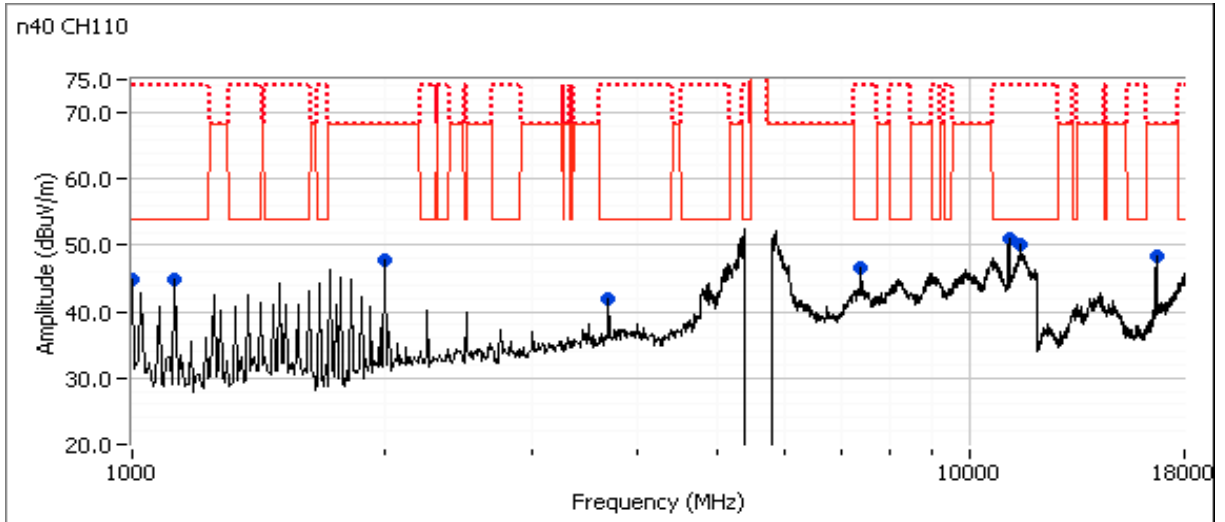

Client: Vivint Wireless	Job Number: J96091
Model: 1520 (4x4 5GHz 802.11 Client)	T-Log Number: T96173
	Project Manager: Irene Rademacher
Contact: Venkat Kalkunte	Project Coordinator: -
Standard: FCC 15.B / 15.407 (New Rules)	Class: N/A

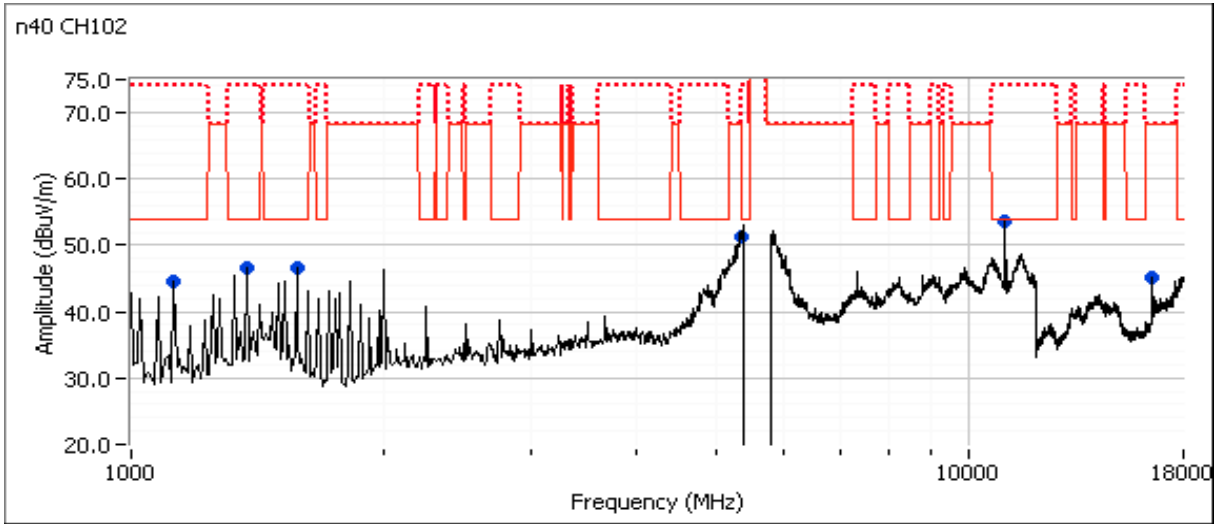



EMC Test Data

Client: Vivint Wireless	Job Number: J96091
Model: 1520 (4x4 5GHz 802.11 Client)	T-Log Number: T96173
	Project Manager: Irene Rademacher
Contact: Venkat Kalkunte	Project Coordinator: -
Standard: FCC 15.B / 15.407 (New Rules)	Class: N/A

Run #6d: High Channel

Date of Test: 10/29/14, 10/30/14, 10/31/14
 Test Engineer: Rafael Varelas/Jack Liu
 Test Location: FT Chamber# 4

Config. Used: 1
 Config Change: -
 EUT Voltage: PoE

Channel: 142 Mode: 11n40
 Tx Chain: 4x4 Data Rate: MCS8

Frequency	Level	Pol	15.209 / 15.247		Detector	Azimuth	Height	Comments
MHz	dB μ V/m	v/h	Limit	Margin	Pk/QP/Avg	degrees	meters	
22840.210	53.3	H	54.0	-0.7	AVG	131	1.6	Note3; RB 1 MHz;VB 10 Hz;Peak
22840.170	60.5	H	74.0	-13.5	PK	131	1.6	RB 1 MHz;VB 3 MHz;Peak
11419.840	50.6	V	54.0	-3.4	AVG	81	2.4	Note3; RB 1 MHz;VB 10 Hz;Peak
11420.770	61.6	V	74.0	-12.4	PK	81	2.4	RB 1 MHz;VB 3 MHz;Peak
1000.010	42.0	H	54.0	-12.0	AVG	32	1.0	RB 100 kHz;VB 10 Hz;Peak
1000.010	45.3	H	74.0	-28.7	PK	32	1.0	RB 100 kHz;VB 300 kHz;Peak
1124.980	42.7	H	54.0	-11.3	AVG	44	1.2	RB 1 MHz;VB 10 Hz;Peak
1125.110	48.1	H	74.0	-25.9	PK	44	1.2	RB 1 MHz;VB 3 MHz;Peak
1675.020	41.6	H	54.0	-12.4	AVG	111	1.4	RB 1 MHz;VB 10 Hz;Peak
1674.980	47.1	H	74.0	-26.9	PK	111	1.4	RB 1 MHz;VB 3 MHz;Peak
3806.730	41.8	H	54.0	-12.2	AVG	139	1.0	RB 1 MHz;VB 10 Hz;Peak
3806.520	47.0	H	74.0	-27.0	PK	139	1.0	RB 1 MHz;VB 3 MHz;Peak
17132.070	63.6	H	68.3	-4.7	PK	9	2.1	RB 1 MHz;VB 3 MHz;Peak
17136.800	64.9	V	68.3	-3.4	PK	91	1.7	RB 1 MHz;VB 3 MHz;Peak
22840.240	50.0	V	54.0	-4.0	AVG	75	1.8	Note3; RB 1 MHz;VB 10 Hz;Peak
22840.460	59.9	V	74.0	-14.1	PK	75	1.8	RB 1 MHz;VB 3 MHz;Peak

- Note: Preliminary Scans made between 18 - 40 GHz with the measurement antenna moved around the card and its antennas 20-50cm from the device. Plot not included.
- Note 1: For emissions in restricted bands, the limit of 15.209 was used which requires average and peak measurements.
- Note 2: For emissions outside of the restricted bands the limit is -27dBm/MHz eirp (68.3dBuV/m). The measurement method required is a peak measurement (RB=1MHz, VB \geq 3MHz, peak detector).

Client: Vivint Wireless	Job Number: J96091
Model: 1520 (4x4 5GHz 802.11 Client)	T-Log Number: T96173
	Project Manager: Irene Rademacher
Contact: Venkat Kalkunte	Project Coordinator: -
Standard: FCC 15.B / 15.407 (New Rules)	Class: N/A

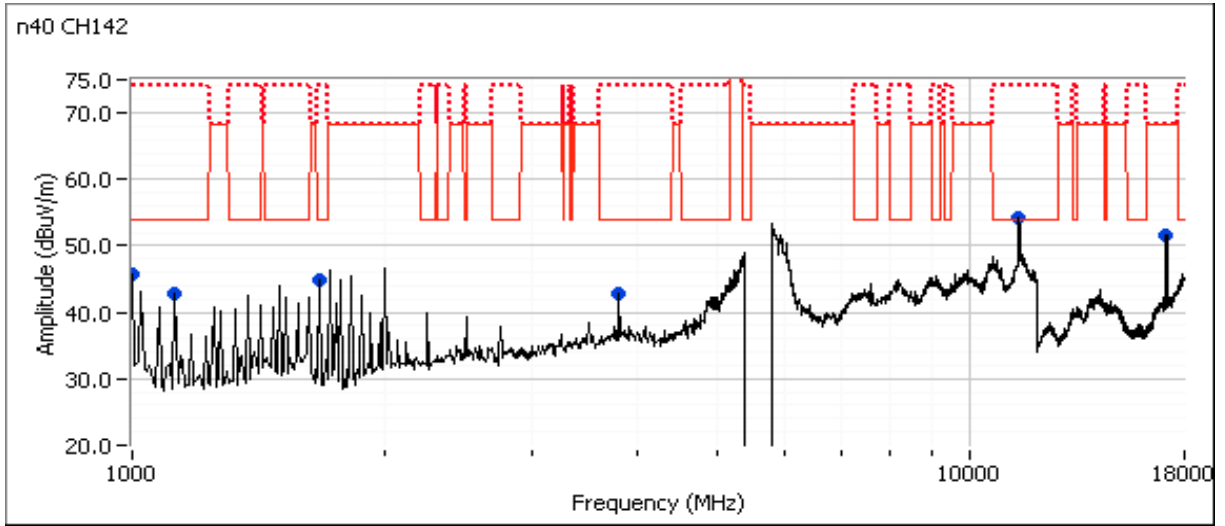



EMC Test Data

Client: Vivint Wireless	Job Number: J96091
Model: 1520 (4x4 5GHz 802.11 Client)	T-Log Number: T96173
	Project Manager: Irene Rademacher
Contact: Venkat Kalkunte	Project Coordinator: -
Standard: FCC 15.B / 15.407 (New Rules)	Class: N/A

Run #7, Radiated Spurious Emissions, 1,000 - 40,000 MHz. Operation in the 5725-5850 MHz Band

Date of Test: 10/29/14, 10/30/14, 10/31/14 Config. Used: 1
 Test Engineer: Jack Liu / Rafael Varelas Config Change: -
 Test Location: FT Chamber# 4 EUT Voltage: PoE

Run #7a: Center Channel

Channel: 157 Mode: 11n20 pre scan is using power setting 21
 Tx Chain: 4x4 Data Rate: MCS8

Frequency	Level	Pol	15.209 / 15E		Detector	Azimuth	Height	Comments
MHz	dB μ V/m	v/h	Limit	Margin	PK/QP/Avg	degrees	meters	
Power setting : 20								
11569.930	53.9	H	54.0	-0.1	AVG	18	1.9	Note3; RB 1 MHz;VB 10 Hz;Peak
11570.200	65.7	H	74.0	-8.3	PK	18	1.9	RB 1 MHz;VB 3 MHz;Peak
1000.020	42.9	H	54.0	-11.1	AVG	41	1.8	RB 1 MHz;VB 10 Hz;Peak
1000.130	48.6	H	74.0	-25.4	PK	41	1.8	RB 1 MHz;VB 3 MHz;Peak
1125.020	43.2	H	54.0	-10.8	AVG	51	1.2	RB 1 MHz;VB 10 Hz;Peak
1125.030	49.1	H	74.0	-24.9	PK	51	1.2	RB 1 MHz;VB 3 MHz;Peak
1724.990	53.0	H	68.3	-15.3	PK	103	1.2	RB 1 MHz;VB 3 MHz;Peak
7713.420	43.8	H	54.0	-10.2	AVG	119	2.4	RB 1 MHz;VB 10 Hz;Peak
7713.180	52.9	H	74.0	-21.1	PK	119	2.4	RB 1 MHz;VB 3 MHz;Peak
1675.020	45.0	H	54.0	-9.0	AVG	122	1.2	RB 1 MHz;VB 10 Hz;Peak
1675.070	51.1	H	74.0	-22.9	PK	122	1.2	RB 1 MHz;VB 3 MHz;Peak
1999.940	50.9	H	68.3	-17.4	PK	149	1.8	RB 1 MHz;VB 3 MHz;Peak
3856.710	42.2	H	54.0	-11.8	AVG	149	1.6	RB 1 MHz;VB 10 Hz;Peak
3856.740	48.6	H	74.0	-25.4	PK	149	1.6	RB 1 MHz;VB 3 MHz;Peak
17351.930	66.2	H	68.3	-2.1	PK	53	1.6	RB 1 MHz;VB 3 MHz;Peak
17367.460	66.9	V	68.3	-1.4	PK	57	1.9	RB 1 MHz;VB 3 MHz;Peak
23140.200	59.6	H	68.3	-8.7	PK	130	1.7	RB 1 MHz;VB 3 MHz;Peak
23140.380	60.8	V	68.3	-7.5	PK	59	1.8	RB 1 MHz;VB 3 MHz;Peak

Note: Preliminary Scans made between 18 - 40 GHz with the measurement antenna moved around the card and its antennas 20-50cm from the device. Plot not included.

Note 1: For emissions in restricted bands, the limit of 15.209 was used which requires average and peak measurements.

Note 2: For emissions outside of the restricted bands the limit is -27dBm/MHz eirp (68.3dBuV/m). The measurement method required is a peak measurement (RB=1MHz, VB≥3MHz, peak detector).

Client: Vivint Wireless	Job Number: J96091
Model: 1520 (4x4 5GHz 802.11 Client)	T-Log Number: T96173
	Project Manager: Irene Rademacher
Contact: Venkat Kalkunte	Project Coordinator: -
Standard: FCC 15.B / 15.407 (New Rules)	Class: N/A

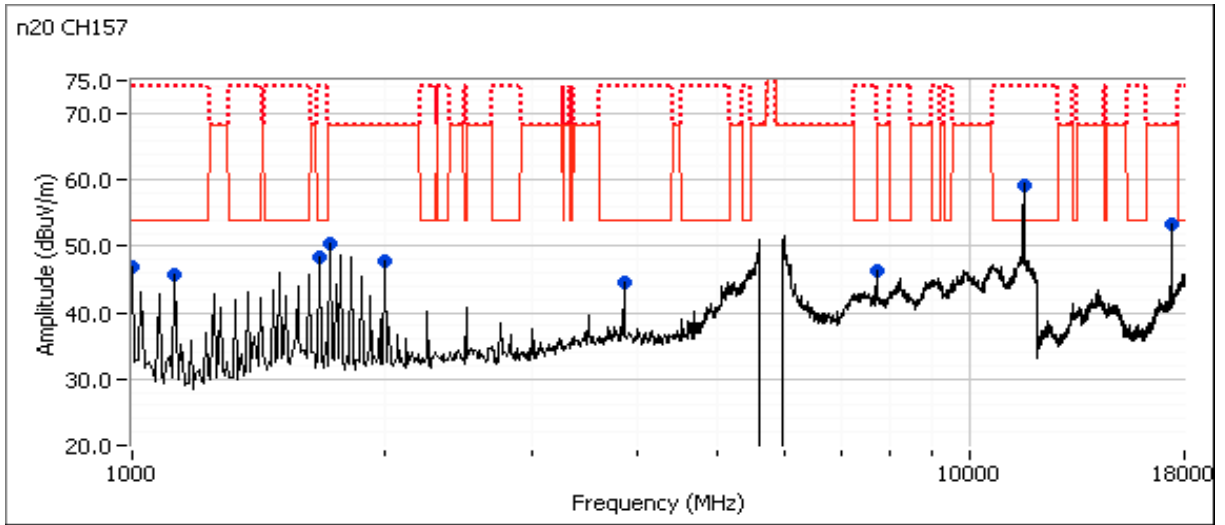



EMC Test Data

Client: Vivint Wireless	Job Number: J96091
Model: 1520 (4x4 5GHz 802.11 Client)	T-Log Number: T96173
	Project Manager: Irene Rademacher
Contact: Venkat Kalkunte	Project Coordinator: -
Standard: FCC 15.B / 15.407 (New Rules)	Class: N/A

Run #7b: Center Channel

Channel: 159 Mode: 11n40 pre scan is using power setting 21
 Tx Chain: 4x4 Data Rate: MCS8

Frequency	Level	Pol	15.209 / 15E		Detector	Azimuth	Height	Comments
MHz	dB μ V/m	v/h	Limit	Margin	Pk/QP/Avg	degrees	meters	
Power setting : 20								
11590.130	53.5	H	54.0	-0.5	AVG	18	1.8	Note3; RB 1 MHz;VB 10 Hz;Peak
11598.600	67.7	H	74.0	-6.3	PK	18	1.8	RB 1 MHz;VB 3 MHz;Peak
1125.080	44.8	H	54.0	-9.2	AVG	48	1.5	RB 1 MHz;VB 10 Hz;Peak
1125.130	49.0	H	74.0	-25.0	PK	48	1.5	RB 1 MHz;VB 3 MHz;Peak
1500.020	45.8	H	54.0	-8.2	AVG	63	1.9	RB 1 MHz;VB 10 Hz;Peak
1499.940	50.3	H	74.0	-23.7	PK	63	1.9	RB 1 MHz;VB 3 MHz;Peak
7726.670	43.1	V	54.0	-10.9	AVG	129	2.5	RB 1 MHz;VB 10 Hz;Peak
7726.630	50.8	V	74.0	-23.2	PK	129	2.5	RB 1 MHz;VB 3 MHz;Peak
2000.070	51.5	H	68.3	-16.8	PK	148	1.8	RB 1 MHz;VB 3 MHz;Peak
6035.080	60.2	V	68.3	-8.1	PK	261	2.0	RB 1 MHz;VB 3 MHz;Peak
3863.390	42.9	V	54.0	-11.1	AVG	276	1.9	RB 1 MHz;VB 10 Hz;Peak
3863.350	48.8	V	74.0	-25.2	PK	276	1.9	RB 1 MHz;VB 3 MHz;Peak
17391.200	64.9	H	68.3	-3.4	PK	55	1.8	RB 1 MHz;VB 3 MHz;Peak
17387.800	65.7	V	68.3	-2.6	PK	69	1.8	RB 1 MHz;VB 3 MHz;Peak
23177.270	62.5	H	68.3	-5.8	PK	59	1.8	RB 1 MHz;VB 3 MHz;Peak
23183.770	59.6	V	68.3	-8.7	PK	59	1.9	RB 1 MHz;VB 3 MHz;Peak

Note:	<i>Preliminary Scans made between 18 - 40 GHz with the measurement antenna moved around the card and its antennas 20-50cm from the device. Plot not included.</i>
Note 1:	For emissions in restricted bands, the limit of 15.209 was used which requires average and peak measurements.
Note 2:	For emissions outside of the restricted bands the limit is -27dBm/MHz eirp (68.3dBuV/m). The measurement method required is a peak measurement (RB=1MHz, VB≥3MHz, peak detector).

Client: Vivint Wireless	Job Number: J96091
Model: 1520 (4x4 5GHz 802.11 Client)	T-Log Number: T96173
	Project Manager: Irene Rademacher
Contact: Venkat Kalkunte	Project Coordinator: -
Standard: FCC 15.B / 15.407 (New Rules)	Class: N/A

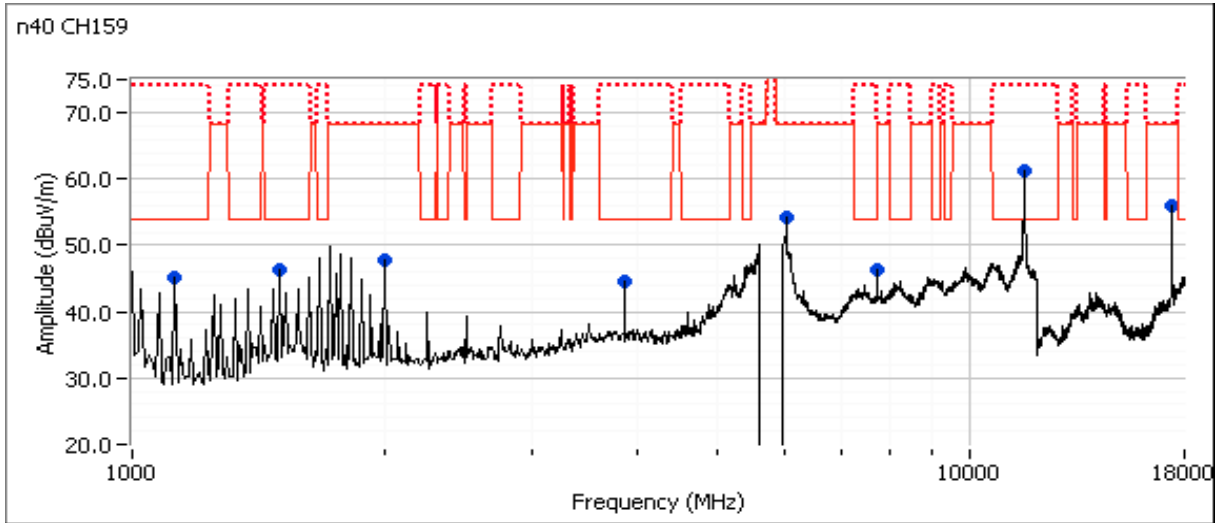



EMC Test Data

Client: Vivint Wireless	Job Number: J96091
Model: 1520 (4x4 5GHz 802.11 Client)	T-Log Number: T96173
	Project Manager: Irene Rademacher
Contact: Venkat Kalkunte	Project Coordinator: -
Standard: FCC 15.B / 15.407 (New Rules)	Class: N/A

Run #8: Radiated Spurious Emissions, 1,000 - 40000 MHz. Operating Mode: Worse case from Run #7

Date of Test: 10/29/14, 10/30/14, 10/31/14 Config. Used: 1
 Test Engineer: Rafael Varelas/Jack Liu Config Change: -
 Test Location: FT Chamber# 4 EUT Voltage: PoE

Run #8a: Low Channel

Channel: 149 Mode: 11n20
 Tx Chain: 4x4 Data Rate: MCS8

Frequency MHz	Level dB μ V/m	Pol v/h	15.209 / 15.247		Detector Pk/QP/Avg	Azimuth degrees	Height meters	Comments
			Limit	Margin				
11490.080	53.7	H	54.0	-0.3	AVG	14	1.8	Note 3, RB 1 MHz;VB 10 Hz;Peak
11490.750	66.3	H	74.0	-7.7	PK	14	1.8	RB 1 MHz;VB 3 MHz;Peak
3830.040	42.3	H	54.0	-11.7	AVG	140	1.3	RB 1 MHz;VB 10 Hz;Peak
3830.030	47.7	H	74.0	-26.3	PK	140	1.3	RB 1 MHz;VB 3 MHz;Peak
1675.010	44.4	H	54.0	-9.6	AVG	107	1.2	RB 1 MHz;VB 10 Hz;Peak
1674.980	50.0	H	74.0	-24.0	PK	107	1.2	RB 1 MHz;VB 3 MHz;Peak
1125.010	42.8	H	54.0	-11.2	AVG	38	1.1	RB 1 MHz;VB 10 Hz;Peak
1125.030	48.2	H	74.0	-25.8	PK	38	1.1	RB 1 MHz;VB 3 MHz;Peak
1000.020	42.6	H	54.0	-11.4	AVG	32	1.0	RB 1 MHz;VB 10 Hz;Peak
1000.140	48.1	H	74.0	-25.9	PK	32	1.0	RB 1 MHz;VB 3 MHz;Peak
17234.130	65.2	H	68.3	-3.1	PK	58	1.7	RB 1 MHz;VB 3 MHz;Peak
17230.470	67.0	V	68.3	-1.3	PK	91	1.7	RB 1 MHz;VB 3 MHz;Peak
22980.200	52.5	H	54.0	-1.5	AVG	130	1.6	Note 3, RB 1 MHz;VB 10 Hz;Peak
22979.980	60.2	H	74.0	-13.8	PK	130	1.6	RB 1 MHz;VB 3 MHz;Peak
22980.190	49.5	V	54.0	-4.5	AVG	72	1.8	Note 3, RB 1 MHz;VB 10 Hz;Peak
22980.170	58.2	V	74.0	-15.8	PK	72	1.8	RB 1 MHz;VB 3 MHz;Peak

Note: Preliminary Scans made between 18 - 40 GHz with the measurement antenna moved around the card and its antennas 20-50cm from the device. Plot not included.

Client: Vivint Wireless	Job Number: J96091
Model: 1520 (4x4 5GHz 802.11 Client)	T-Log Number: T96173
	Project Manager: Irene Rademacher
Contact: Venkat Kalkunte	Project Coordinator: -
Standard: FCC 15.B / 15.407 (New Rules)	Class: N/A

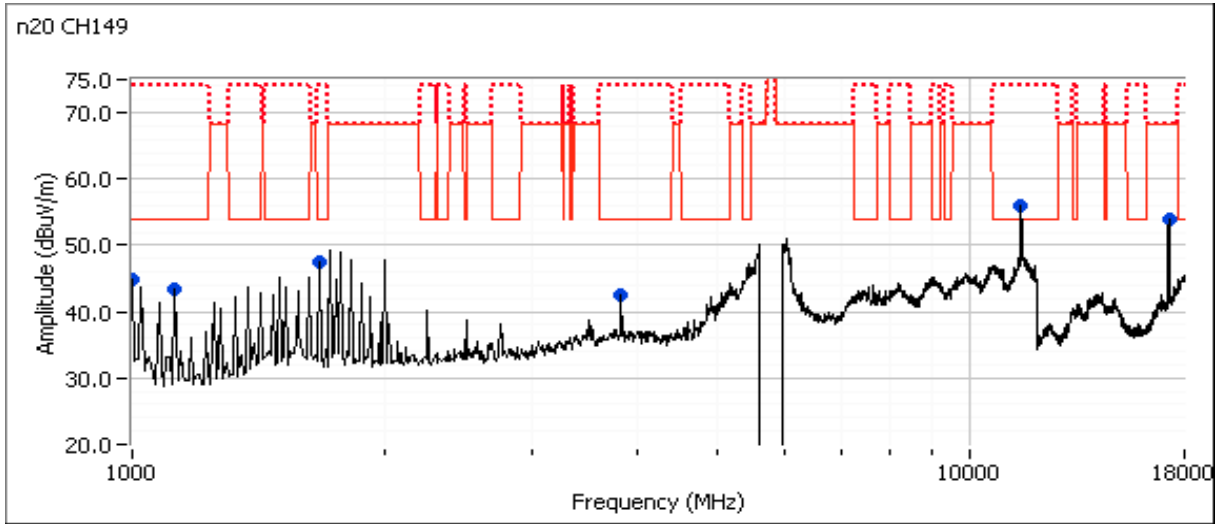



EMC Test Data

Client: Vivint Wireless	Job Number: J96091
Model: 1520 (4x4 5GHz 802.11 Client)	T-Log Number: T96173
	Project Manager: Irene Rademacher
Contact: Venkat Kalkunte	Project Coordinator: -
Standard: FCC 15.B / 15.407 (New Rules)	Class: N/A

Run #8b: High Channel

Channel: 165 Mode: 11n20
 Tx Chain: 4x4 Data Rate: MCS8

Frequency	Level	Pol	15.209 / 15.247		Detector	Azimuth	Height	Comments
MHz	dB μ V/m	v/h	Limit	Margin	PK/QP/Avg	degrees	meters	
Power setting : 20								
11649.950	52.8	H	54.0	-1.2	AVG	1	2.1	Note 3, RB 1 MHz;VB 10 Hz;Peak
11650.820	64.7	H	74.0	-9.3	PK	1	2.1	RB 1 MHz;VB 3 MHz;Peak
3883.330	41.7	H	54.0	-12.3	AVG	260	1.4	RB 1 MHz;VB 10 Hz;Peak
3883.480	47.4	H	74.0	-26.6	PK	260	1.4	RB 1 MHz;VB 3 MHz;Peak
1675.010	44.3	H	54.0	-9.7	AVG	109	1.4	RB 1 MHz;VB 10 Hz;Peak
1675.140	49.8	H	74.0	-24.2	PK	109	1.4	RB 1 MHz;VB 3 MHz;Peak
1000.030	42.2	H	54.0	-11.8	AVG	62	1.0	RB 1 MHz;VB 10 Hz;Peak
1000.090	47.9	H	74.0	-26.1	PK	62	1.0	RB 1 MHz;VB 3 MHz;Peak
1125.000	43.1	H	54.0	-10.9	AVG	39	1.1	RB 1 MHz;VB 10 Hz;Peak
1125.060	48.2	H	74.0	-25.8	PK	39	1.1	RB 1 MHz;VB 3 MHz;Peak
17477.330	67.1	H	68.3	-1.2	PK	53	1.8	RB 1 MHz;VB 3 MHz;Peak
17477.870	66.8	V	68.3	-1.5	PK	56	1.8	RB 1 MHz;VB 3 MHz;Peak
23299.870	58.8	H	68.3	-9.5	PK	129	1.8	RB 1 MHz;VB 3 MHz;Peak
23300.690	60.8	V	68.3	-7.5	PK	58	2.3	RB 1 MHz;VB 3 MHz;Peak

Note: Preliminary Scans made between 18 - 40 GHz with the measurement antenna moved around the card and its antennas 20-50cm from the device. Plot not included.

Client: Vivint Wireless	Job Number: J96091
Model: 1520 (4x4 5GHz 802.11 Client)	T-Log Number: T96173
	Project Manager: Irene Rademacher
Contact: Venkat Kalkunte	Project Coordinator: -
Standard: FCC 15.B / 15.407 (New Rules)	Class: N/A

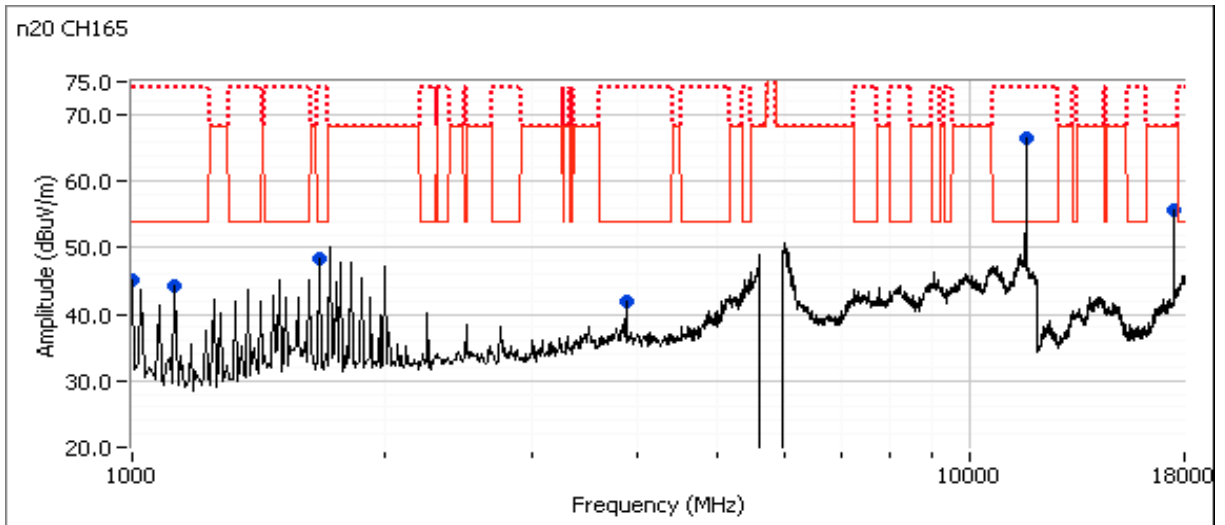



EMC Test Data

Client: Vivint Wireless	Job Number: J96091
Model: 1520 (4x4 5GHz 802.11 Client)	T-Log Number: T96173
	Project Manager: Irene Rademacher
Contact: Venkat Kalkunte	Project Coordinator: -
Standard: FCC 15.B / 15.407 (New Rules)	Class: N/A

RSS 210 and FCC 15.407 (UNII) Radiated Spurious Emissions

Test Specific Details

Objective: The objective of this test session is to perform final qualification testing of the EUT with respect to the specification listed above.

General Test Configuration

The EUT and all local support equipment were located on the turntable for radiated spurious emissions testing. For radiated emissions testing the measurement antenna was located 3 meters from the EUT, unless otherwise noted.

Ambient Conditions: Temperature: 19-22 °C
Rel. Humidity: 35-45 %

Summary of Results

Run #	Mode	Channel	Target Power Setting	Passing Power Setting	Test Performed	Limit	Result / Margin
1	ac80	42 - 5210MHz	21	18	Radiated Emissions, 1 - 40 GHz	FCC 15.209 / 15 E	49.8 dBµV/m @ 5444.5 MHz (-4.2 dB)
2	ac80	58 - 5290MHz	21	18	Radiated Emissions, 1 - 40 GHz	FCC 15.209 / 15 E	46.1 dBµV/m @ 1500.1 MHz (-7.9 dB)
3	ac80	106 - 5530MHz	21	18	Radiated Emissions, 1 - 40 GHz	FCC 15.209 / 15 E	44.0 dBµV/m @ 7386.8 MHz (-10.0 dB)
	ac80	122 - 5610MHz	21	21	Radiated Emissions, 1 - 40 GHz	FCC 15.209 / 15 E	46.8 dBµV/m @ 11222.1 MHz (-7.2 dB)
	ac80	138 - 5690MHz	21	21	Radiated Emissions, 1 - 40 GHz	FCC 15.209 / 15 E	48.0 dBµV/m @ 11380.0 MHz (-6.0 dB)
4	ac80	155 - 5775MHz	21	21	Radiated Emissions, 1 - 40 GHz	FCC 15.209 / 15 E	49.4 dBµV/m @ 11574.1 MHz (-4.6 dB)

Client:	Vivint Wireless	Job Number:	J96091
Model:	1520 (4x4 5GHz 802.11 Client)	T-Log Number:	T96173
		Project Manager:	Irene Rademacher
Contact:	Venkat Kalkunte	Project Coordinator:	-
Standard:	FCC 15.B / 15.407 (New Rules)	Class:	N/A

Modifications Made During Testing

No modifications were made to the EUT during testing

Deviations From The Standard

No deviations were made from the requirements of the standard.

Procedure Comments:

Measurements performed in accordance with FCC KDB 789033

Peak measurements performed with: RBW=1MHz, VBW=3MHz, peak detector, max hold, auto sweep time

Unless otherwise stated/noted, emission has duty cycle $\geq 98\%$ and was measured using RBW=1MHz, VBW=10Hz, peak detector, linear average mode, auto sweep time, max hold.

Preliminary testing showed no radio related emissions below 1GHz

Testing below 1GHz was performed with the EUT at 1.5m height. C63.10 does not specify the height for floor standing products and the 1.5m height was considered more representative of the final end use installation.

Mode	Data Rate	Duty Cycle (x)	Constant DC?	T (ms)	Pwr Cor Factor*	Lin Volt Cor Factor**	Min VBW for FS (Hz)
11ac80	MCS8	92.1%	yes	0.58	0.36	0.72	1724

Sample Notes

Sample S/N: Prototype

Driver: -

Antenna: 6dBi

Measurement Specific Notes:

Note 1:	For emissions outside of the restricted bands the limit is -27dBm/MHz eirp (68.3dBuV/m). The measurement method required is a peak measurement (RB=1MHz, VB \geq 3MHz, peak detector). Per KDB 789033 2) c) (i), compliance can be demonstrated by meeting the average and peak limits of 15.209, as an alternative.
Note 2:	Emission has duty cycle $\geq 98\%$, average measurement performed: RBW=1MHz, VBW=3MHz, RMS, Power averaging, auto sweep, trace average 100 traces
Note 3:	Emission has duty cycle $< 98\%$, but constant, average measurement performed: RBW=1MHz, VBW=10Hz, peak detector, linear averaging, auto sweep, trace average $100 * 1/DC$ traces, measurement corrected by Linear Voltage correction factor
Note 5:	Emission has duty cycle $< 98\%$, but constant, average measurement performed: RBW=1MHz, VBW=3MHz, RMS, Power averaging, auto sweep, trace average $100 * 1/DC$ traces, measurement corrected by Pwr correction factor
Note 6:	Plots of the average and peak bandedge do not account for any duty cycle correction. Refer to the tabluar results for final measurements.



EMC Test Data

Client: Vivint Wireless	Job Number: J96091
Model: 1520 (4x4 5GHz 802.11 Client)	T-Log Number: T96173
	Project Manager: Irene Rademacher
Contact: Venkat Kalkunte	Project Coordinator: -
Standard: FCC 15.B / 15.407 (New Rules)	Class: N/A

Run #1, Radiated Spurious Emissions, 1,000 - 40,000 MHz. Operation in the 5150-5250 MHz Band

Date of Test: 12/10/2014 and 12/15/2014

Test Location: Chamber #4

Test Engineer: M. Birgani

EUT Voltage: POE

Channel: 42 - 5210MHz

Power Setting: 18

Tx Chain: 4x4

Data Rate: MCS 8

Mode: AC80

Packet Size: 1000

Frequency MHz	Level dB μ V/m	Pol v/h	15.209 / 15E		Detector PK/QP/Avg	Azimuth degrees	Height meters	Comments
			Limit	Margin				
5444.470	49.8	V	54.0	-4.2	AVG	119	1.6	RB 1 MHz;VB 10 Hz;Peak, Note 7
5051.470	49.6	V	54.0	-4.4	AVG	119	1.6	RB 1 MHz;VB 10 Hz;Peak, Note 7
1500.060	46.4	H	54.0	-7.6	AVG	268	2.0	RB 1 MHz;VB 10 Hz;Peak
10451.330	58.4	V	68.3	-9.9	Peak	213	1.6	RB 1 MHz;VB 3 MHz;Peak
5051.250	62.8	V	74.0	-11.2	PK	119	1.6	RB 1 MHz;VB 3 MHz;Peak, Note 7
6962.400	55.4	V	68.3	-12.9	Peak	106	1.6	RB 1 MHz;VB 3 MHz;Peak
5441.240	61.0	V	74.0	-13.0	PK	119	1.6	RB 1 MHz;VB 3 MHz;Peak, Note 7
1499.900	50.5	H	74.0	-23.5	PK	268	2.0	RB 1 MHz;VB 3 MHz;Peak

Note:	Preliminary Scans made between 18 - 40 GHz with the measurement antenna moved around the card and its antennas 20-50cm from the device. Plot not included.
Note 1:	For emissions in restricted bands, the limit of 15.209 was used which requires average and peak measurements.
Note 2:	For emissions outside of the restricted bands the limit is -27dBm/MHz eirp (68.3dB μ V/m). The measurement method required is a peak measurement (RB=1MHz, VB \geq 3MHz, peak detector).
Note 7:	This signal was measured after removing the band reject. Prescan was perform with power setting of 21dBm.

Client: Vivint Wireless	Job Number: J96091
Model: 1520 (4x4 5GHz 802.11 Client)	T-Log Number: T96173
Contact: Venkat Kalkunte	Project Manager: Irene Rademacher
Standard: FCC 15.B / 15.407 (New Rules)	Project Coordinator: -
	Class: N/A

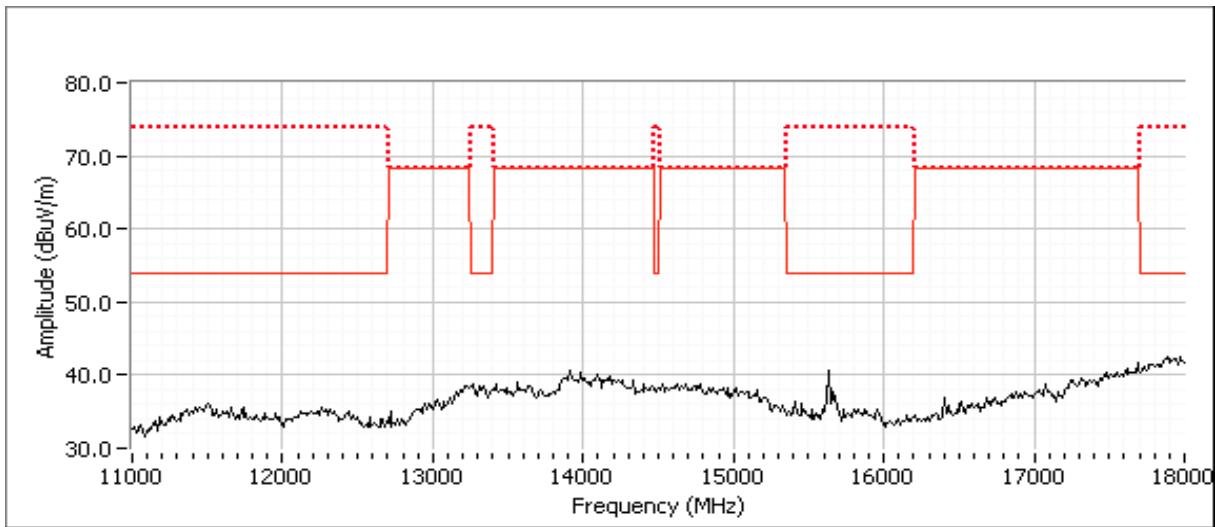
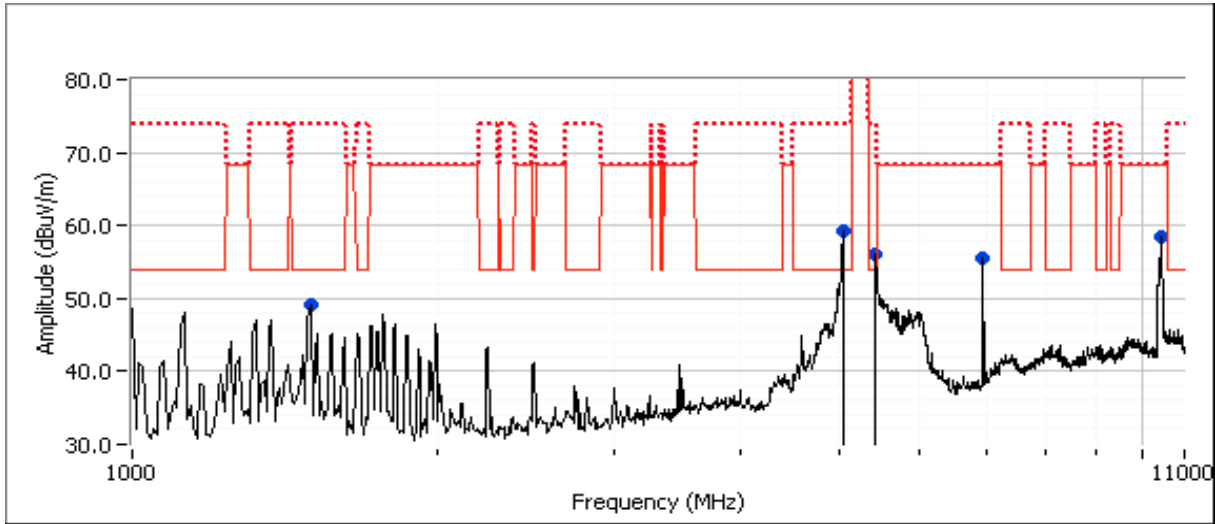



EMC Test Data

Client: Vivint Wireless	Job Number: J96091
Model: 1520 (4x4 5GHz 802.11 Client)	T-Log Number: T96173
	Project Manager: Irene Rademacher
Contact: Venkat Kalkunte	Project Coordinator: -
Standard: FCC 15.B / 15.407 (New Rules)	Class: N/A

Run #2, Radiated Spurious Emissions, 1,000 - 40,000 MHz. Operation in the 5250-5350 MHz Band

Date of Test: 12/10/2014 and 12/15/2014

Test Location: Chamber #4

Test Engineer: M. Birgani

EUT Voltage: POE

Channel: 58 - 5290MHz

Power Setting: 18

Tx Chain: 4x4

Data Rate: MCS 8

Mode: AC80

Packet Size: 1000

Frequency MHz	Level dB μ V/m	Pol v/h	15.209 / 15E		Detector PK/QP/Avg	Azimuth degrees	Height meters	Comments
			Limit	Margin				
1500.060	46.1	H	54.0	-7.9	AVG	260	2.0	RB 1 MHz;VB 10 Hz;Peak
15865.000	40.5	V	54.0	-13.5	Peak	241	1.7	RB 1 MHz;VB 10 Hz;Peak, Note 3
7050.000	45.7	V	68.3	-22.6	PK	1	1.6	RB 1 MHz;VB 3 MHz;Peak
1499.900	50.7	H	74.0	-23.3	PK	260	2.0	RB 1 MHz;VB 3 MHz;Peak
15865.000	44.8	V	74.0	-29.2	Peak	241	1.7	RB 1 MHz;VB 3 MHz;Peak

Note:	Preliminary Scans made between 18 - 40 GHz with the measurement antenna moved around the card and its antennas 20-50cm from the device. Plot not included.
Note 1:	For emissions in restricted bands, the limit of 15.209 was used which requires average and peak measurements.
Note 2:	For emissions outside of the restricted bands the limit is -27dBm/MHz eirp (68.3dBuV/m). The measurement method required is a peak measurement (RB=1MHz, VB \geq 3MHz, peak detector).

Client: Vivint Wireless	Job Number: J96091
Model: 1520 (4x4 5GHz 802.11 Client)	T-Log Number: T96173
Contact: Venkat Kalkunte	Project Manager: Irene Rademacher
Standard: FCC 15.B / 15.407 (New Rules)	Project Coordinator: -
	Class: N/A

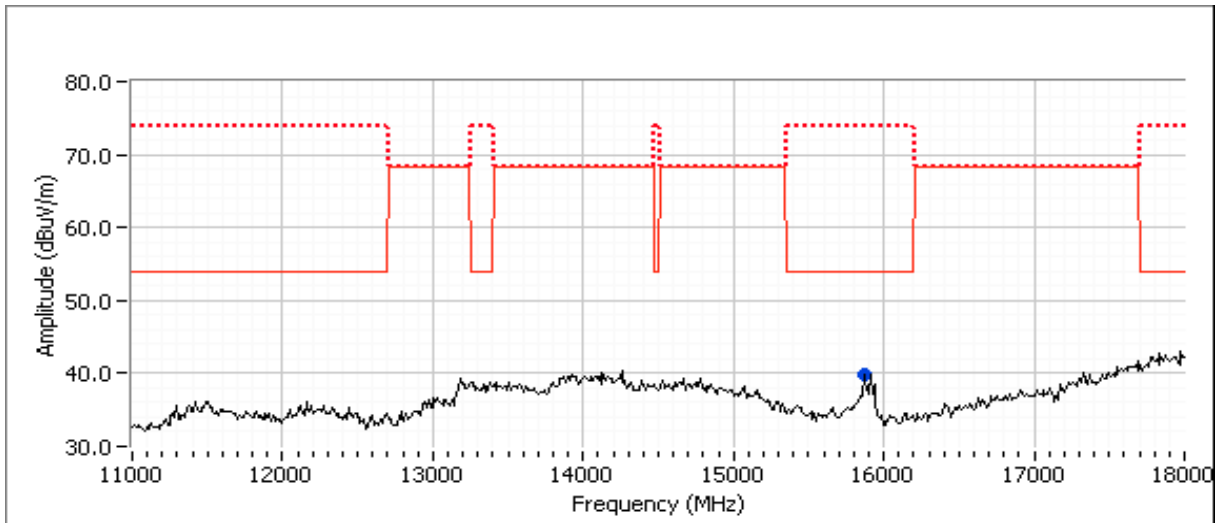
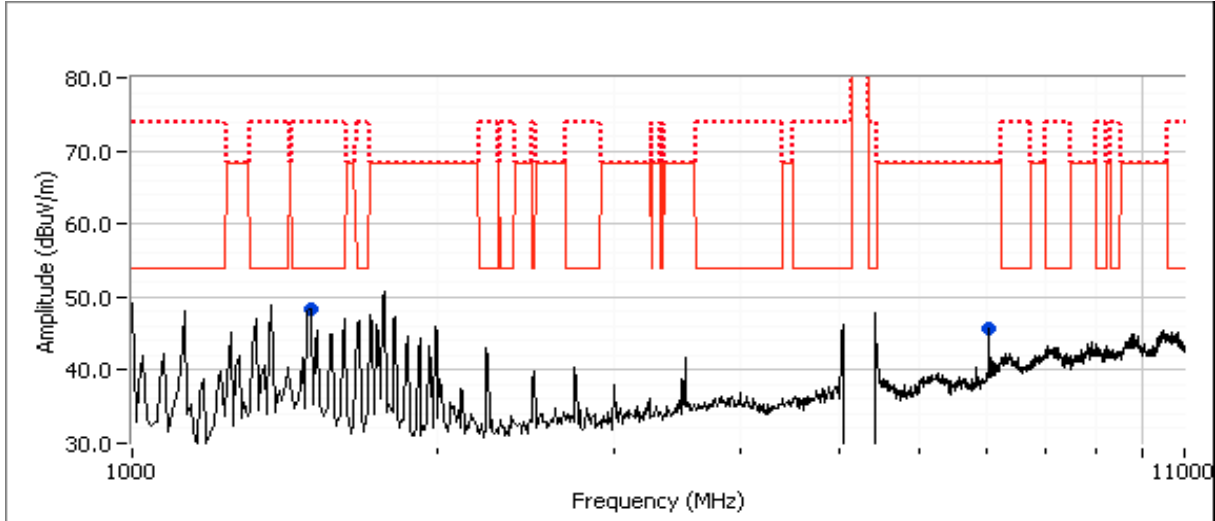



EMC Test Data

Client: Vivint Wireless	Job Number: J96091
Model: 1520 (4x4 5GHz 802.11 Client)	T-Log Number: T96173
	Project Manager: Irene Rademacher
Contact: Venkat Kalkunte	Project Coordinator: -
Standard: FCC 15.B / 15.407 (New Rules)	Class: N/A

Run #3, Radiated Spurious Emissions, 1,000 - 40,000 MHz. Operation in the 5470-5725 MHz Band

Date of Test: 12/10/2014 and 12/15/2014

Test Location: Chamber #4

Test Engineer: M. Birgani

EUT Voltage: POE

Channel: 106 - 5530 MHz

Power Setting: 18

Tx Chain: 4x4

Data Rate: MCS 8

Mode: AC80

Packet Size: 1000

Frequency MHz	Level dB μ V/m	Pol v/h	15.209 / 15E		Detector PK/QP/Avg	Azimuth degrees	Height meters	Comments
			Limit	Margin				
7386.750	44.0	H	54.0	-10.0	AVG	11	1.5	RB 1 MHz;VB 10 Hz;Peak
11058.330	43.9	V	54.0	-10.1	AVG	191	1.8	RB 1 MHz;VB 10 Hz;Peak, Note 3
1375.060	42.5	H	54.0	-11.5	AVG	8	0.9	RB 1 MHz;VB 10 Hz;Peak
1125.060	42.1	H	54.0	-11.9	AVG	219	1.0	RB 1 MHz;VB 10 Hz;Peak
11058.330	53.8	H	74.0	-20.2	PK	191	1.8	RB 1 MHz;VB 3 MHz;Peak
7386.560	51.9	H	74.0	-22.1	PK	11	1.5	RB 1 MHz;VB 3 MHz;Peak
1374.920	47.1	H	74.0	-26.9	PK	8	0.9	RB 1 MHz;VB 3 MHz;Peak
16646.670	41.2	V	68.3	-27.1	PK	252	1.7	RB 1 MHz;VB 3 MHz;Peak
1124.930	46.8	H	74.0	-27.2	PK	219	1.0	RB 1 MHz;VB 3 MHz;Peak

Note:	Preliminary Scans made between 18 - 40 GHz with the measurement antenna moved around the card and its antennas 20-50cm from the device. Plot not included.
Note 1:	For emissions in restricted bands, the limit of 15.209 was used which requires average and peak measurements.
Note 2:	For emissions outside of the restricted bands the limit is -27dBm/MHz eirp (68.3dB μ V/m). The measurement method required is a peak measurement (RB=1MHz, VB \geq 3MHz, peak detector).

Client: Vivint Wireless	Job Number: J96091
Model: 1520 (4x4 5GHz 802.11 Client)	T-Log Number: T96173
	Project Manager: Irene Rademacher
Contact: Venkat Kalkunte	Project Coordinator: -
Standard: FCC 15.B / 15.407 (New Rules)	Class: N/A

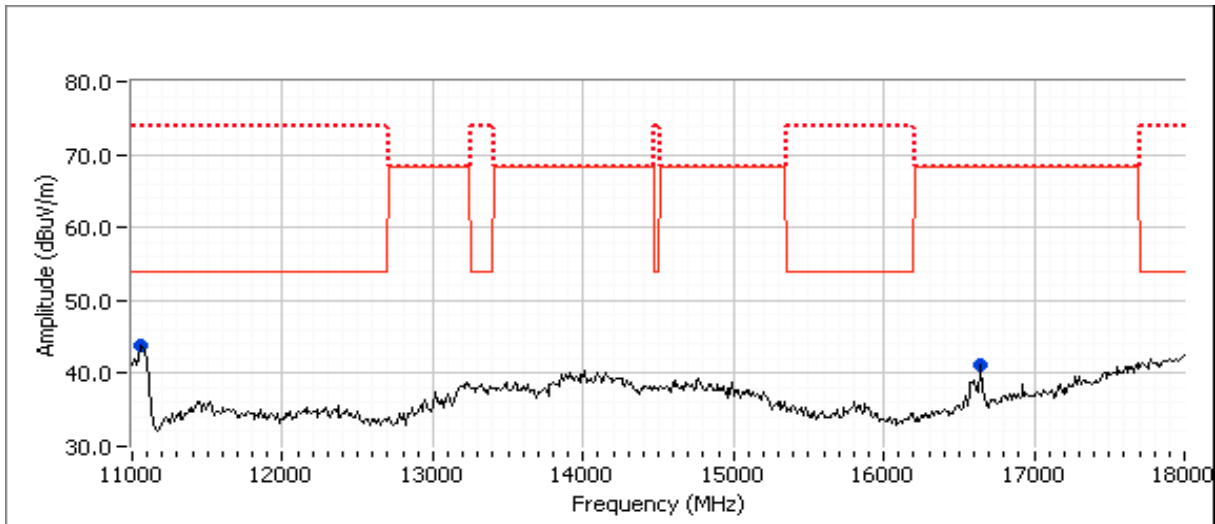
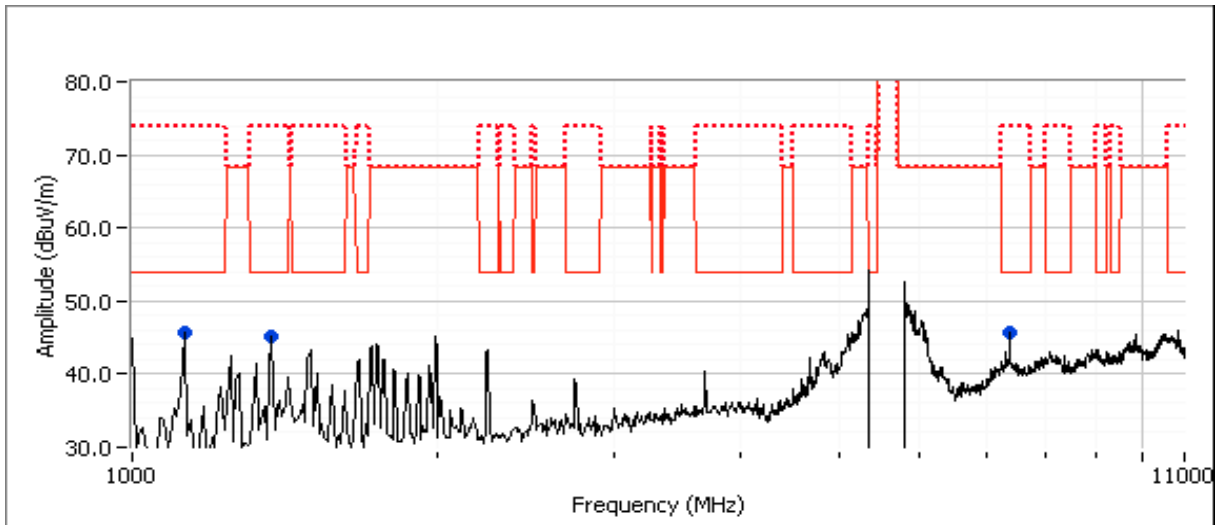



EMC Test Data

Client: Vivint Wireless	Job Number: J96091
Model: 1520 (4x4 5GHz 802.11 Client)	T-Log Number: T96173
	Project Manager: Irene Rademacher
Contact: Venkat Kalkunte	Project Coordinator: -
Standard: FCC 15.B / 15.407 (New Rules)	Class: N/A

Run #3b: Center Channel
 Date of Test: 12/12/2014 & 12/15/2014
 Test Engineer: Jack Liu; M. Birgani
 Test Location: FT Chamber# 4
 EUT Voltage: POE

Channel: 122 - 5610 MHz
 Tx Chain: 4x4
 Mode: AC80

Power Setting: 21
 Data Rate: MCS 8
 Packet Size: 1000

Frequency MHz	Level dB μ V/m	Pol v/h	15.209 / 15E		Detector PK/QP/Avg	Azimuth degrees	Height meters	Comments
			Limit	Margin				
11222.070	46.8	V	54.0	-7.2	AVG	253	1.0	RB 1 MHz;VB 10 Hz;Peak, Note 3
1125.040	46.6	H	54.0	-7.4	AVG	255	1.7	RB 1 MHz;VB 10 Hz;Peak
1500.090	45.4	H	54.0	-8.6	AVG	246	1.5	RB 1 MHz;VB 10 Hz;Peak
5120.200	43.7	V	54.0	-10.3	AVG	84	1.4	RB 1 MHz;VB 10 Hz;Peak
7480.130	43.1	H	54.0	-10.9	AVG	316	1.3	RB 1 MHz;VB 10 Hz;Peak
1000.050	43.0	H	54.0	-11.0	AVG	245	1.1	RB 1 MHz;VB 10 Hz;Peak
3740.050	38.7	H	54.0	-15.3	AVG	329	1.0	RB 1 MHz;VB 10 Hz;Peak
11222.530	58.5	V	74.0	-15.5	PK	253	1.0	RB 1 MHz;VB 3 MHz;Peak
5120.250	56.5	V	74.0	-17.5	PK	84	1.4	RB 1 MHz;VB 3 MHz;Peak
16870.000	47.7	V	68.3	-20.6	PK	295	1.7	RB 1 MHz;VB 3 MHz;Peak
7480.080	52.9	H	74.0	-21.1	PK	316	1.3	RB 1 MHz;VB 3 MHz;Peak
1125.020	50.7	H	74.0	-23.3	PK	255	1.7	RB 1 MHz;VB 3 MHz;Peak
1499.990	50.5	H	74.0	-23.5	PK	246	1.5	RB 1 MHz;VB 3 MHz;Peak
1000.110	49.2	H	74.0	-24.8	PK	245	1.1	RB 1 MHz;VB 3 MHz;Peak
3740.270	47.2	H	74.0	-26.8	PK	329	1.0	RB 1 MHz;VB 3 MHz;Peak

Note: Preliminary Scans made between 18 - 40 GHz with the measurement antenna moved around the card and its antennas 20-50cm from the device. Plot not included.

Note 1: For emissions in restricted bands, the limit of 15.209 was used which requires average and peak measurements.

Note 2: For emissions outside of the restricted bands the limit is -27dBm/MHz eirp (68.3dBuV/m). The measurement method required is a peak measurement (RB=1MHz, VB \geq 3MHz, peak detector).

Client: Vivint Wireless	Job Number: J96091
Model: 1520 (4x4 5GHz 802.11 Client)	T-Log Number: T96173
	Project Manager: Irene Rademacher
Contact: Venkat Kalkunte	Project Coordinator: -
Standard: FCC 15.B / 15.407 (New Rules)	Class: N/A

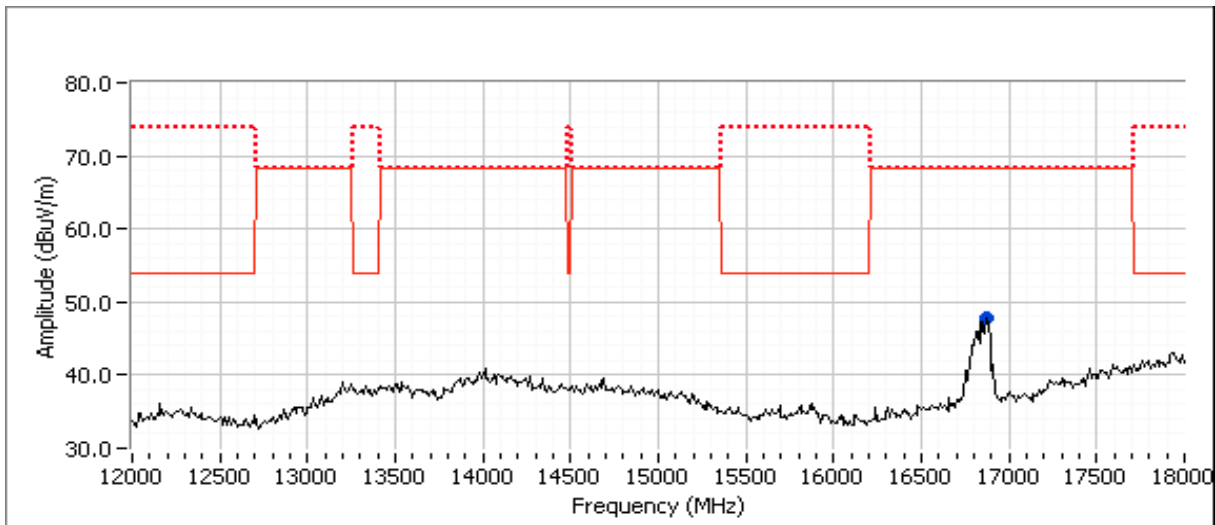
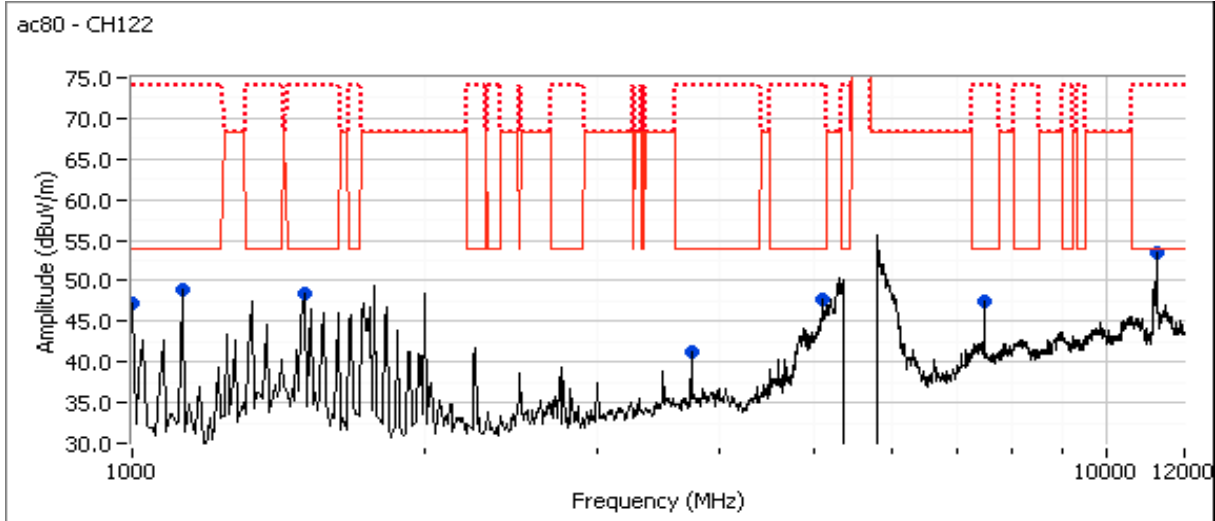



EMC Test Data

Client: Vivint Wireless	Job Number: J96091
Model: 1520 (4x4 5GHz 802.11 Client)	T-Log Number: T96173
	Project Manager: Irene Rademacher
Contact: Venkat Kalkunte	Project Coordinator: -
Standard: FCC 15.B / 15.407 (New Rules)	Class: N/A

Run #3c: High Channel

Date of Test: 12/12/2014 and 12/15/2014

Test Location: FT Chamber# 4

Test Engineer: Jack Liu & M. Birgani

EUT Voltage: POE

Channel: 138 - 5690 MHz

Power Setting: 21

Tx Chain: 4x4

Data Rate: MCS 8

Mode: AC80

Packet Size: 1000

Frequency MHz	Level dB μ V/m	Pol v/h	15.209 / 15E		Detector Pk/QP/Avg	Azimuth degrees	Height meters	Comments
			Limit	Margin				
11380.000	48.0	H	54.0	-6.0	AVG	220	2.5	RB 1 MHz;VB 10 Hz;Peak, Note 3
1125.080	46.5	H	54.0	-7.5	AVG	249	1.3	RB 1 MHz;VB 10 Hz;Peak
1500.060	45.4	H	54.0	-8.6	AVG	241	1.0	RB 1 MHz;VB 10 Hz;Peak
7586.750	43.1	H	54.0	-10.9	AVG	333	1.7	RB 1 MHz;VB 10 Hz;Peak
3793.440	40.9	V	54.0	-13.1	AVG	118	1.8	RB 1 MHz;VB 10 Hz;Peak
11377.400	58.3	H	74.0	-15.7	PK	220	2.5	RB 1 MHz;VB 3 MHz;Peak
7586.820	53.9	H	74.0	-20.1	PK	333	1.7	RB 1 MHz;VB 3 MHz;Peak
17070.000	47.0	H	68.3	-21.3	Peak	296	2.0	RB 1 MHz;VB 3 MHz;Peak
1500.020	50.8	H	74.0	-23.2	PK	241	1.0	RB 1 MHz;VB 3 MHz;Peak
1124.990	50.6	H	74.0	-23.4	PK	249	1.3	RB 1 MHz;VB 3 MHz;Peak
3793.240	47.9	V	74.0	-26.1	PK	118	1.8	RB 1 MHz;VB 3 MHz;Peak
2499.930	46.8	V	74.0	-27.2	PK	234	1.8	RB 1 MHz;VB 3 MHz;Peak
2500.040	38.2	V	68.3	-30.1	AVG	234	1.8	RB 1 MHz;VB 10 Hz;Peak

Note: Preliminary Scans made between 18 - 40 GHz with the measurement antenna moved around the card and its antennas 20-50cm from the device. Plot not included.

Note 1: For emissions in restricted bands, the limit of 15.209 was used which requires average and peak measurements.

Note 2: For emissions outside of the restricted bands the limit is -27dBm/MHz eirp (68.3dBuV/m). The measurement method required is a peak measurement (RB=1MHz, VB \geq 3MHz, peak detector).

Client: Vivint Wireless	Job Number: J96091
Model: 1520 (4x4 5GHz 802.11 Client)	T-Log Number: T96173
	Project Manager: Irene Rademacher
Contact: Venkat Kalkunte	Project Coordinator: -
Standard: FCC 15.B / 15.407 (New Rules)	Class: N/A

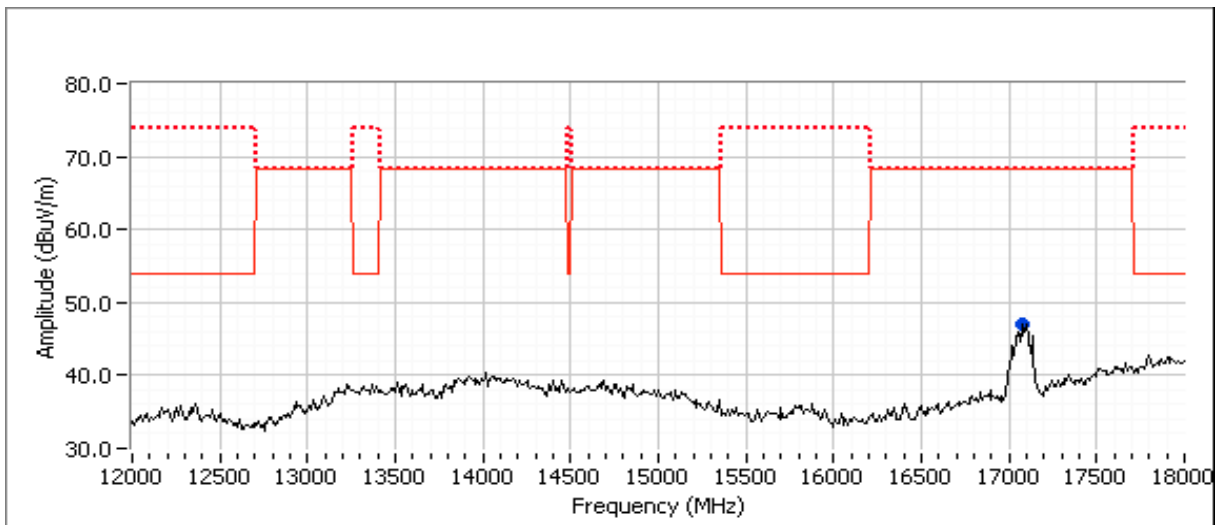
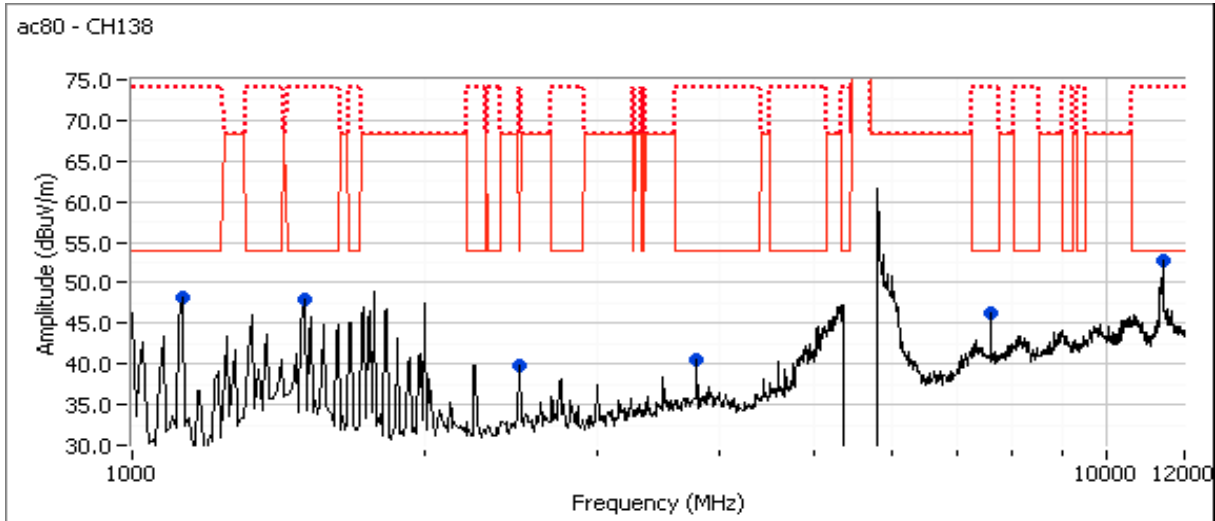



EMC Test Data

Client: Vivint Wireless	Job Number: J96091
Model: 1520 (4x4 5GHz 802.11 Client)	T-Log Number: T96173
	Project Manager: Irene Rademacher
Contact: Venkat Kalkunte	Project Coordinator: -
Standard: FCC 15.B / 15.407 (New Rules)	Class: N/A

Run #4, Radiated Spurious Emissions, 1,000 - 40,000 MHz. Operation in the 5725-5850 MHz Band
 Date of Test: 12/15/14 Test Location: FT Chamber# 4
 Test Engineer: M. Birgani EUT Voltage: POE

Run #4a: Center Channel

Channel: 155 Mode: ac80
 Tx Chain: 4x4 Data Rate: MCS 8 Power Setting: 21
 Channel: 155 - 5775MHz Packet Size: 1000

Frequency MHz	Level dB μ V/m	Pol v/h	15.209 / 15E		Detector Pk/QP/Avg	Azimuth degrees	Height meters	Comments
			Limit	Margin				
11574.100	49.4	H	54.0	-4.6	AVG	90	2.1	RB 1 MHz;VB 10 Hz;Peak
1500.020	44.5	H	54.0	-9.5	AVG	245	1.3	RB 1 MHz;VB 10 Hz;Peak
11577.500	63.7	H	74.0	-10.3	PK	90	2.1	RB 1 MHz;VB 3 MHz;Peak
17310.000	54.9	H	68.3	-13.4	PK	293	2.0	RB 1 MHz;VB 3 MHz;Peak
7726.070	37.7	V	54.0	-16.3	AVG	275	2.5	RB 1 MHz;VB 10 Hz;Peak
7725.470	49.4	V	74.0	-24.6	PK	275	2.5	RB 1 MHz;VB 3 MHz;Peak
1500.190	49.1	H	74.0	-24.9	PK	245	1.3	RB 1 MHz;VB 3 MHz;Peak

- Note: Preliminary Scans made between 18 - 40 GHz with the measurement antenna moved around the card and its antennas 20-50cm from the device. Plot not included.
- Note 1: For emissions in restricted bands, the limit of 15.209 was used which requires average and peak measurements.
- Note 2: For emissions outside of the restricted bands the limit is -27dBm/MHz eirp (68.3dBuV/m). The measurement method required is a peak measurement (RB=1MHz, VB \geq 3MHz, peak detector).

Client: Vivint Wireless	Job Number: J96091
Model: 1520 (4x4 5GHz 802.11 Client)	T-Log Number: T96173
	Project Manager: Irene Rademacher
Contact: Venkat Kalkunte	Project Coordinator: -
Standard: FCC 15.B / 15.407 (New Rules)	Class: N/A

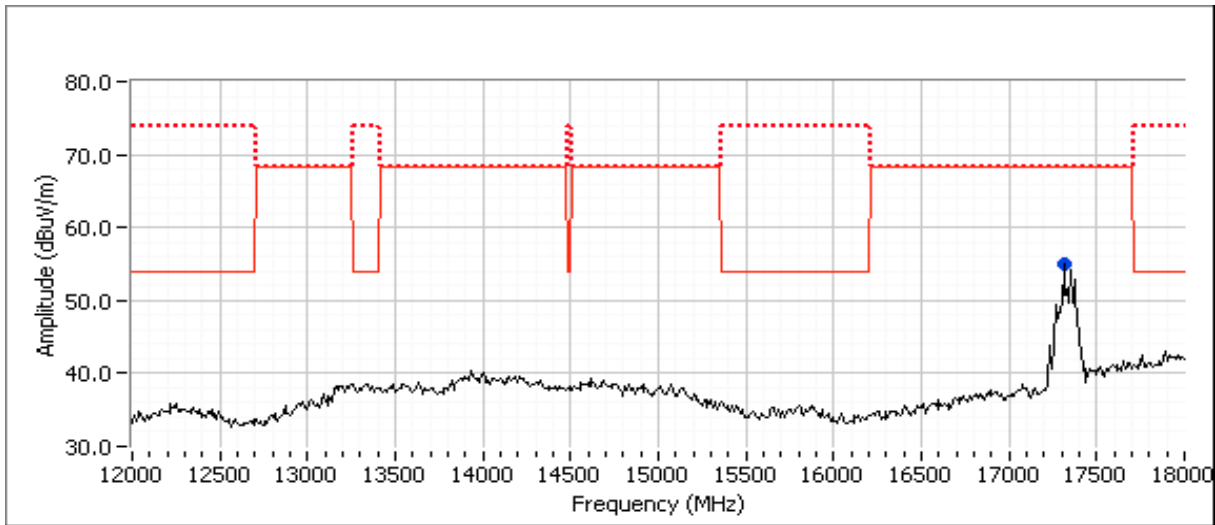
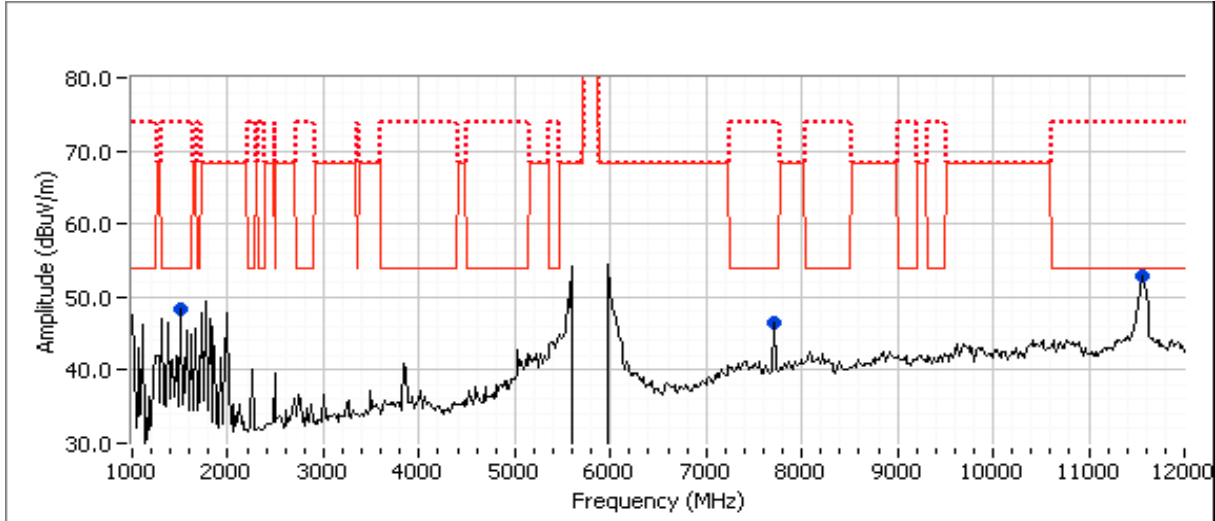

Client: Vivint Wireless	Job Number: J96091
Model: 1520 (4x4 5GHz 802.11 Client)	T-Log Number: T96173
	Project Manager: Irene Rademacher
Contact: Venkat Kalkunte	Project Coordinator: -
Standard: FCC 15.B / 15.407 (New Rules)	Class: N/A

RSS-210 (LELAN) and FCC 15.407(UNII) Antenna Port Measurements Power, PSD, Peak Excursion, Bandwidth and Spurious Emissions

Test Specific Details

Objective: The objective of this test session is to perform final qualification testing of the EUT with respect to the specification listed above.

Summary of Results

Run #	Test Performed	Limit	Pass / Fail	Result / Margin
1	Power, 5150 - 5250MHz	15.407(a) (1)	Pass	n20: 20.5dBm (112.7 mW)
1	PSD, 5150 - 5250MHz	15.407(a) (1)	Pass	n20: 7.5 dBm/MHz
1	Power, 5250 - 5350MHz	15.407(a) (2)	Pass	n20: 20.5dBm (112.8 mW)
1	PSD, 5250 - 5350MHz	15.407(a) (2)	Pass	n20: 7.3 dBm/MHz
1	Max EIRP 5250 - 5350MHz	TPC required if EIRP ≥ 500mW (27dBm). EIRP ≥ 200mW (23dBm) DFS threshold = -64dBm.	Pass	EIRP = 29.5 dBm (898.5 mW)
1	Power, 5470 - 5725MHz	15.407(a) (2)	Pass	n20: 20.96dBm (124.8 mW)
1	PSD, 5470 - 5725MHz	15.407(a) (2)	Pass	n20: 7.7 dBm/MHz
1	Max EIRP 5470 - 5725MHz	TPC required if EIRP ≥ 500mW (27dBm). EIRP ≥ 200mW (23dBm) DFS threshold	Pass	EIRP = 29.97 dBm (993.47 mW)
1	Power, 5725 - 5850MHz	15.407(a) (3)	Pass	n20: 23.9dBm (246.1 mW)
1	PSD, 5725 - 5850MHz	15.407(a) (3)	Pass	n20: 10.7 dBm/MHz
2	26dB Bandwidth	15.407(h)(2)	N/A	n20: 24.5MHz minimum
2	Minimum 6dB Bandwidth for UNII3 band	15.407(e)	Pass	17.6 MHz



EMC Test Data

Client: Vivint Wireless	Job Number: J96091
Model: 1520 (4x4 5GHz 802.11 Client)	T-Log Number: T96173
	Project Manager: Irene Rademacher
Contact: Venkat Kalkunte	Project Coordinator: -
Standard: FCC 15.B / 15.407 (New Rules)	Class: N/A

General Test Configuration

When measuring the conducted emissions from the EUT's antenna port, the antenna port of the EUT was connected to the spectrum analyzer or power meter via a suitable attenuator to prevent overloading the measurement system. All measurements are corrected to allow for the external attenuators and cables used.

Ambient Conditions:

Temperature: 21.4 °C
 Rel. Humidity: 39 %

Modifications Made During Testing

No modifications were made to the EUT during testing

Deviations From The Standard

No deviations were made from the requirements of the standard.

Procedure Comments:

Measurements performed in accordance with FCC KDB 789033

Mode	Data Rate	Duty Cycle (x)	Constant DC?	T (ms)	Pwr Cor Factor*	Lin Volt Cor Factor**	Min VBW for FS (Hz)
n20	6.5	96.5%	yes	2.54	0.16	0.31	394

Sample Notes

Sample S/N: Prototype

Driver: -



EMC Test Data

Client: Vivint Wireless	Job Number: J96091
Model: 1520 (4x4 5GHz 802.11 Client)	T-Log Number: T96173
	Project Manager: Irene Rademacher
Contact: Venkat Kalkunte	Project Coordinator: -
Standard: FCC 15.B / 15.407 (New Rules)	Class: N/A

Antenna Gain Information

Freq	Antenna Gain (dBi) / Chain				BF	MultiChain Legacy	CDD	Sectorized / Xpol	Dir G (PWR)	Dir G (PSD)
	1	2	3	4						
5150-5250	6	6	6	6	Yes	No	Yes	No	9.0	9.0
5250-5350	6	6	6	6	Yes	No	Yes	No	9.0	9.0
5470-5725	6	6	6	6	Yes	No	Yes	No	9.0	9.0
5725-5850	6	6	6	6	Yes	No	Yes	No	9.0	9.0

For devices that support CDD modes

Min # of spatial streams: 2 MCS8 is the lowest rate supported
 Max # of spatial streams: 4

Notes:	BF = beamforming mode supported, Multichain Legacy = 802.11 legacy data rates supported for multichain transmissions, CDD = Cyclic Delay Diversity (or Cyclic Shift Diversity) modes supported, Sectorized / Xpol = antennas are sectorized or cross polarized.
Notes:	Dir G (PWR) = total gain (Gant + Array Gain) for power calculations; GA (PSD) = total gain for PSD calculations based on FCC KDB 662911. Depending on the modes supported, the Array Gain value for power could be different from the PSD value.
Notes:	Array gain for power/psd calculated per DKB 662911. Spatial Multiplexing with Nant=4, Nss=2, for worse case condition. Array gain = $10 \cdot \log(4/2) = 3\text{dB}$.

Note:

- Antenna port number defined
 Port JE09 -Test port 0 ; Port JE10 -Test port 1 ; Port JE11 -Test port 2 ; Port JE12 -Test port 3
- All the measurements measured at the end of the internal cable, not the output on the PCB board.



EMC Test Data

Client: Vivint Wireless	Job Number: J96091
Model: 1520 (4x4 5GHz 802.11 Client)	T-Log Number: T96173
	Project Manager: Irene Rademacher
Contact: Venkat Kalkunte	Project Coordinator: -
Standard: FCC 15.B / 15.407 (New Rules)	Class: N/A

MIMO Device - 5150-5250 MHz Band - FCC

Mode: n20

Max EIRP (mW): 897.3

Frequency (MHz)	Chain	Software Setting	26dB BW (MHz)	Duty Cycle %	Power ¹ dBm	Total Power mW	dBm	FCC Limit dBm	Max Power (W)	Result	
5180	0	16	25.1	96.5	14.0	102.0	20.1	21.0	0.113	Pass	
	1				13.7						
	2				14.0						
	3				13.9						
5200	0	16	24.7	96.5	13.9	101.4	20.1	21.0		0.113	Pass
	1				13.8						
	2				14.0						
	3				13.9						
5240	0	16	25.2	96.5	14.1	112.7	20.5	21.0		0.113	Pass
	1				14.3						
	2				14.6						
	3				14.4						

5150-5250 PSD - FCC

Mode: n20

Frequency (MHz)	Chain	Software Setting	99% BW (MHz)	Duty Cycle %	PSD dBm/MHz	Total PSD ¹ mW/MHz	dBm/MHz	FCC Limit dBm/MHz	IC Limit dBm/MHz	Result
5180	0	16	18.1	96.5	0.9	4.9	6.9	8.0	-	Pass
	1				0.5					
	2				0.9					
	3				0.8					
5200	0	16	18.1	96.5	0.8	4.9	6.9	8.0	-	Pass
	1				0.5					
	2				0.9					
	3				0.6					
5240	0	16	18.1	96.5	1.1	5.6	7.5	8.0	-	Pass
	1				1.2					
	2				1.5					
	3				1.3					

Client: Vivint Wireless	Job Number: J96091
Model: 1520 (4x4 5GHz 802.11 Client)	T-Log Number: T96173
	Project Manager: Irene Rademacher
Contact: Venkat Kalkunte	Project Coordinator: -
Standard: FCC 15.B / 15.407 (New Rules)	Class: N/A

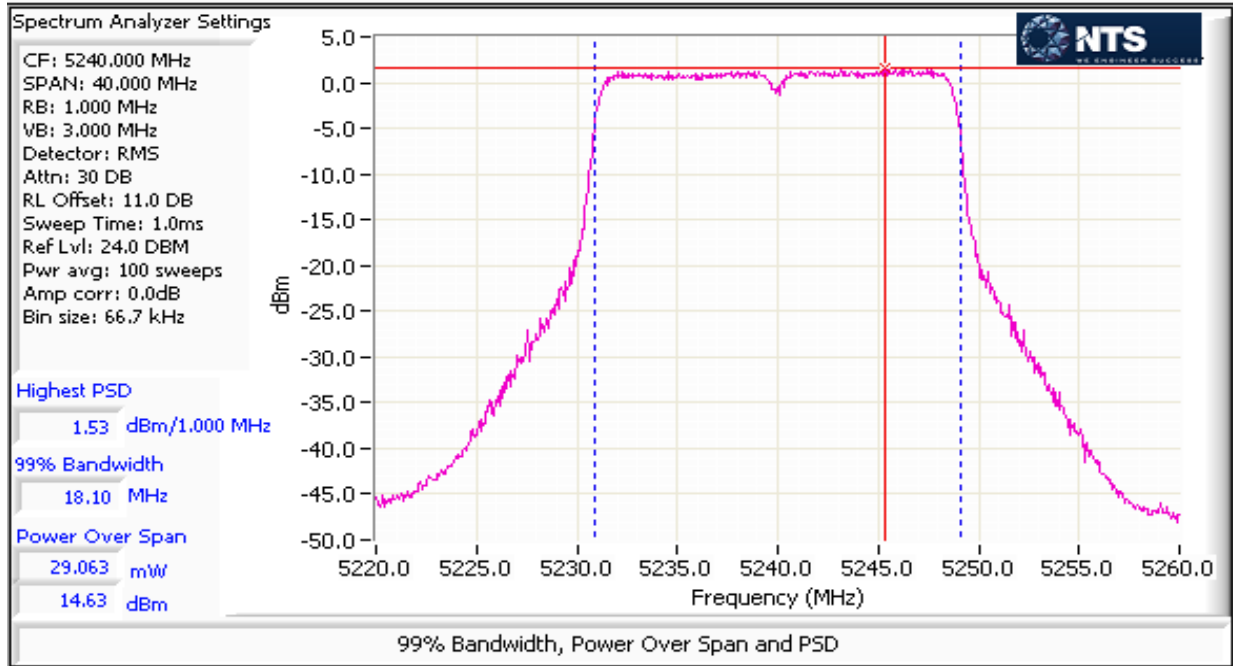



EMC Test Data

Client: Vivint Wireless	Job Number: J96091
Model: 1520 (4x4 5GHz 802.11 Client)	T-Log Number: T96173
	Project Manager: Irene Rademacher
Contact: Venkat Kalkunte	Project Coordinator: -
Standard: FCC 15.B / 15.407 (New Rules)	Class: N/A

MIMO Device - 5250-5350 MHz Band - FCC

Mode: n20

Max EIRP (mW): 898.5

Frequency (MHz)	Chain	Software Setting	26dB BW (MHz)	Duty Cycle %	Power dBm	Total Power ¹ mW	dBm	FCC Limit dBm	Max Power (W)	Result
5260	0	16	24.8	96.5	14.6	111.8	20.5	21.0	0.113	Pass
	1				14.1					
	2				14.3					
	3				14.2					
5300	0	16	24.9	96.5	14.1	110.6	20.4	21.0		Pass
	1				14.4					
	2				14.0					
	3				14.6					
5320	0	16	24.8	96.5	14.6	112.8	20.5	21.0		Pass
	1				14.4					
	2				14.0					
	3				14.4					

MIMO Device 5250-5350 PSD - FCC

Mode: n20

Frequency (MHz)	Chain	Software Setting	99% BW (MHz)	Duty Cycle %	PSD dBm/MHz	Total PSD ¹ mW/MHz	dBm/MHz	FCC Limit dBm/MHz	IC Limit dBm/MHz	Result
5260	0	16	18.1	96.5	1.4	5.4	7.3	8.0	-	Pass
	1				0.9					
	2				1.2					
	3				1.0					
5300	0	16	18.1	96.5	0.8	5.2	7.2	8.0	-	Pass
	1				1.2					
	2				0.7					
	3				1.4					
5320	0	16	18.1	96.5	1.5	5.4	7.3	8.0	-	Pass
	1				1.1					
	2				0.7					
	3				1.3					

Client: Vivint Wireless	Job Number: J96091
Model: 1520 (4x4 5GHz 802.11 Client)	T-Log Number: T96173
	Project Manager: Irene Rademacher
Contact: Venkat Kalkunte	Project Coordinator: -
Standard: FCC 15.B / 15.407 (New Rules)	Class: N/A

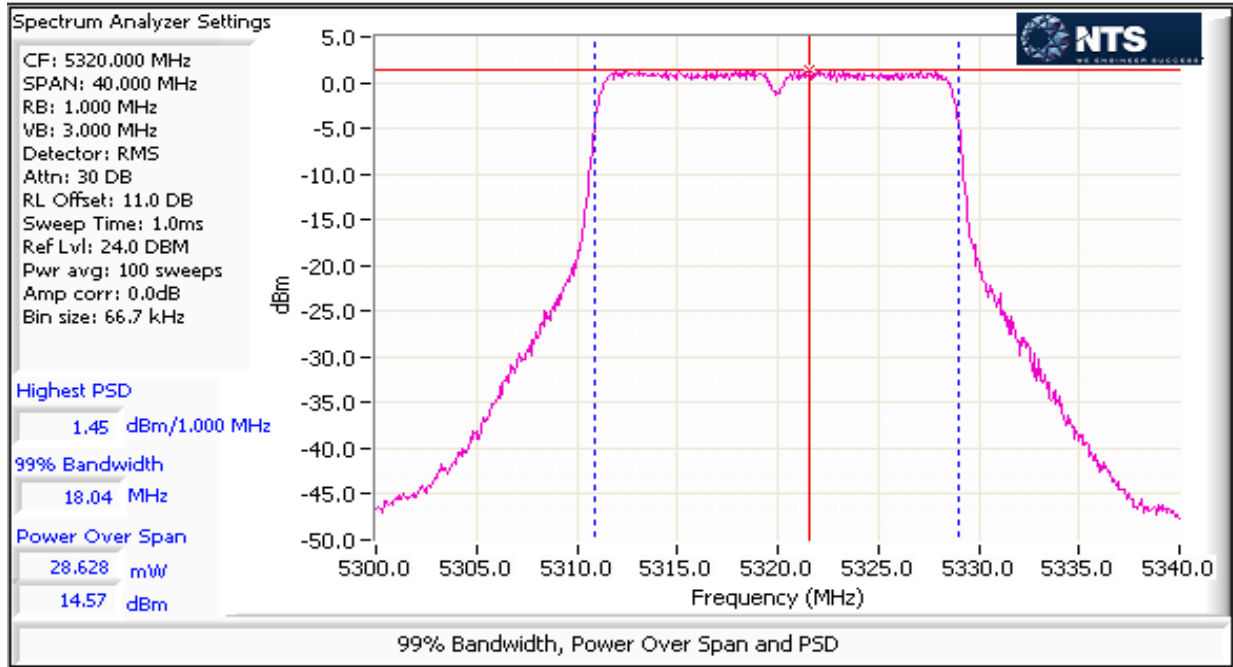



EMC Test Data

Client: Vivint Wireless	Job Number: J96091
Model: 1520 (4x4 5GHz 802.11 Client)	T-Log Number: T96173
	Project Manager: Irene Rademacher
Contact: Venkat Kalkunte	Project Coordinator: -
Standard: FCC 15.B / 15.407 (New Rules)	Class: N/A

MIMO Device - 5470-5725 MHz Band - FCC

Mode: n20

Max EIRP (mW): 993.5

Frequency (MHz)	Chain	Software Setting	26dB BW (MHz)	Duty Cycle %	Power dBm	Total Power ¹ mW	FCC Limit dBm	Max Power (W)	Result	
5500	0	17	24.5	96.5	14.7	124.8	20.96	0.125	Pass	
	1				14.6					
	2				15.4					
	3				14.5					
5580	0	18	24.9	96.5	14.6	122.1	20.9		Pass	
	1				14.5					
	2				14.7					
	3				15.1					
5700	0	17	24.7	96.5	13.8	113.5	20.5		Pass	
	1				13.9					
	2				14.9					
	3				14.8					
802.11ac 20MHz UNII-2ext										
5720	0	17	16.87	96.5	13.1	93.0	19.7		Pass	
	1				12.9					
	2				14.2					
	3				13.7					
UNII-3										
5720	0	17	7.6	96.5	7.5	27.8	14.4	Pass		
	1				7.6					
	2				8.9					
	3				8.9					



EMC Test Data

Client: Vivint Wireless	Job Number: J96091
Model: 1520 (4x4 5GHz 802.11 Client)	T-Log Number: T96173
	Project Manager: Irene Rademacher
Contact: Venkat Kalkunte	Project Coordinator: -
Standard: FCC 15.B / 15.407 (New Rules)	Class: N/A

MIMO Device 5470-5725 PSD - FCC
Mode: n20

Frequency (MHz)	Chain	Software Setting	99% BW (MHz)	Duty Cycle %	PSD dBm/MHz	Total PSD ¹		FCC Limit dBm/MHz	IC Limit dBm/MHz	Result
5500	0	17	18.1	96.5	1.5	5.9	7.7	8.0	-	Pass
	1				1.5					
	2				2.0					
	3				1.3					
5580	0	18	18.1	96.5	1.6	5.9	7.7	8.0	-	Pass
	1				1.2					
	2				1.5					
	3				1.9					
5700	0	17	18.1	96.5	0.6	5.6	7.5	8.0	-	Pass
	1				0.8					
	2				2.0					
	3				1.6					

802.11ac 20MHz

UNII-2ext

5720	0	17	14.09	96.5	1.0	5.7	7.6	8.0	-	Pass
	1				0.8					
	2				2.1					
	3				1.6					

UNII-3

5720	0	17	4.49	96.5	0.9	5.9	7.7	8.0	-	Pass
	1				0.7					
	2				2.2					
	3				2.1					

Client: Vivint Wireless	Job Number: J96091
Model: 1520 (4x4 5GHz 802.11 Client)	T-Log Number: T96173
	Project Manager: Irene Rademacher
Contact: Venkat Kalkunte	Project Coordinator: -
Standard: FCC 15.B / 15.407 (New Rules)	Class: N/A

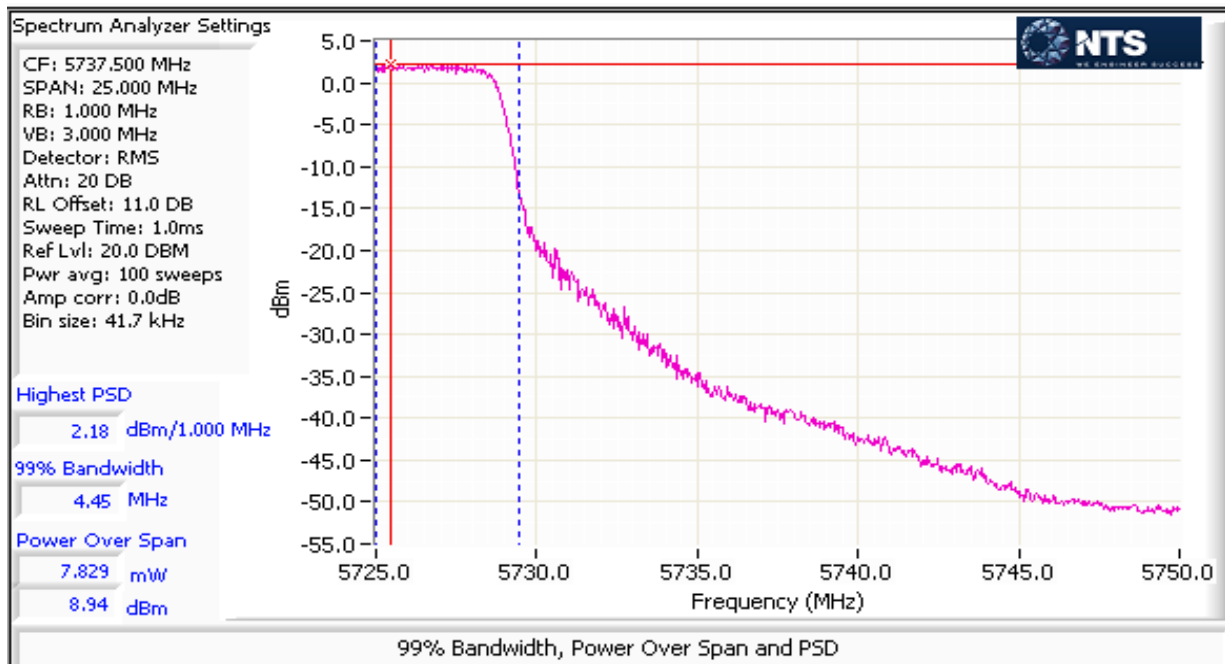
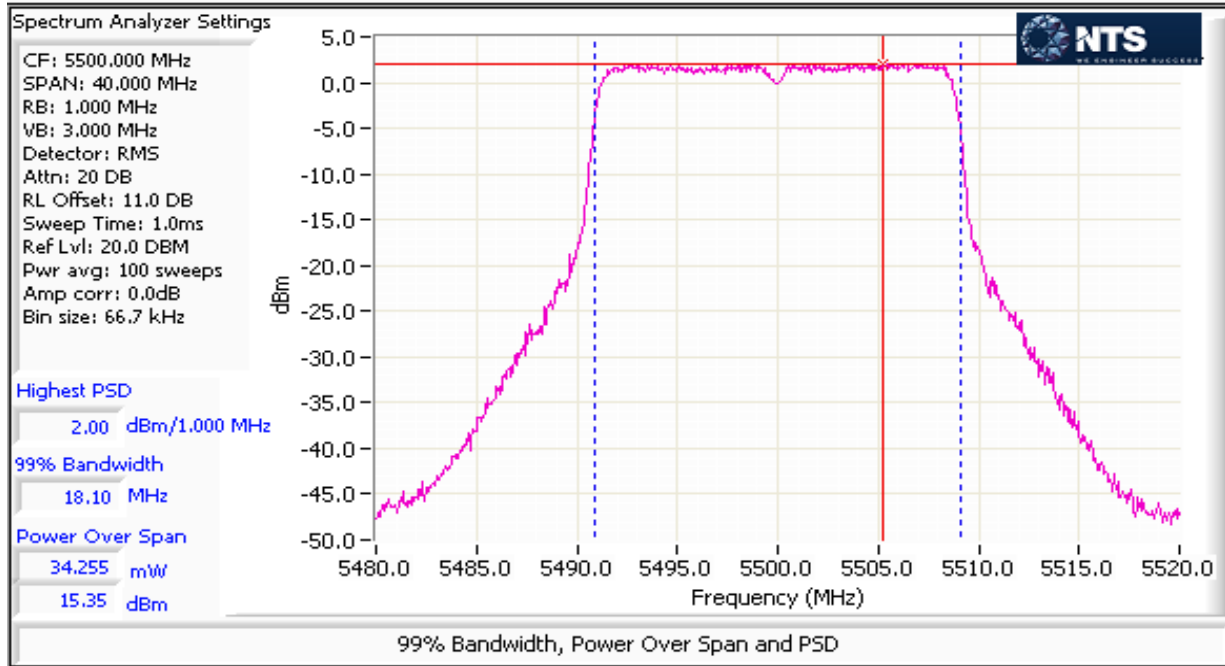

Client: Vivint Wireless	Job Number: J96091
Model: 1520 (4x4 5GHz 802.11 Client)	T-Log Number: T96173
Contact: Venkat Kalkunte	Project Manager: Irene Rademacher
Standard: FCC 15.B / 15.407 (New Rules)	Project Coordinator: -
	Class: N/A

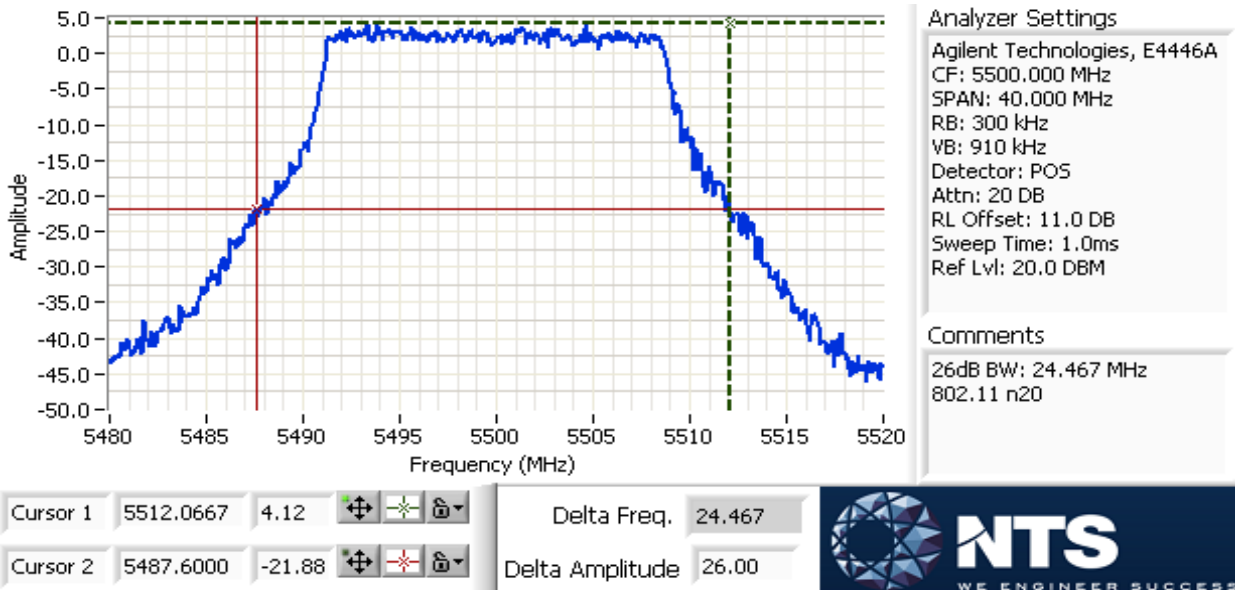
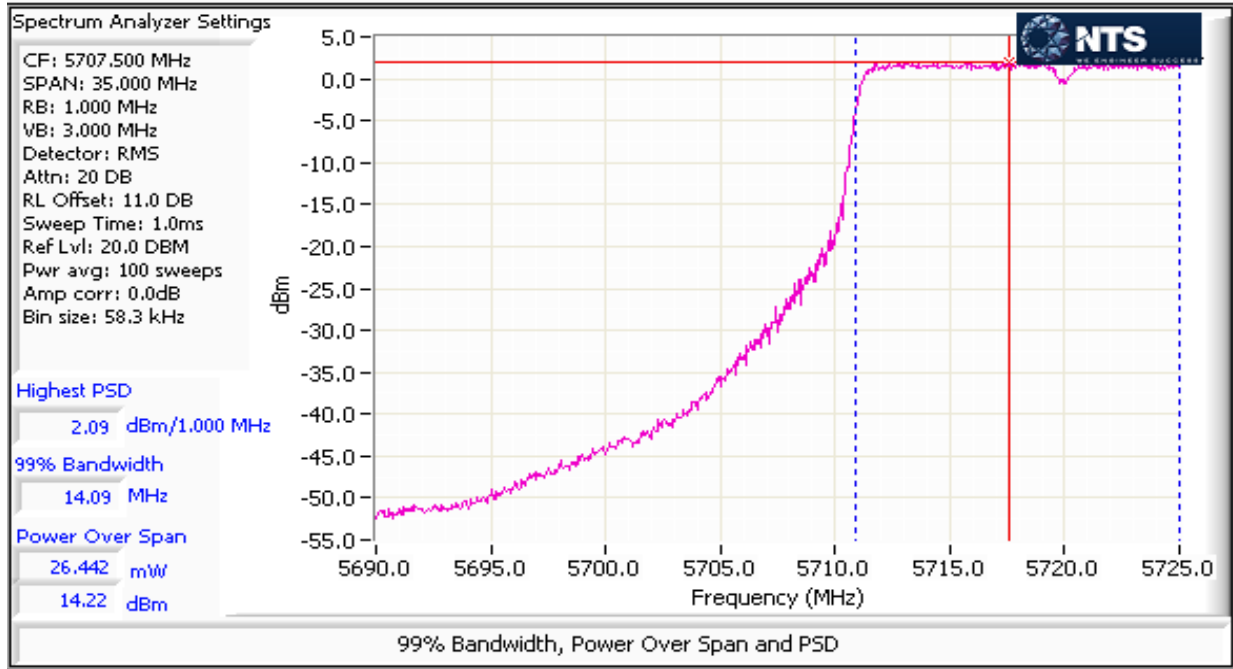



EMC Test Data

Client: Vivint Wireless	Job Number: J96091
Model: 1520 (4x4 5GHz 802.11 Client)	T-Log Number: T96173
	Project Manager: Irene Rademacher
Contact: Venkat Kalkunte	Project Coordinator: -
Standard: FCC 15.B / 15.407 (New Rules)	Class: N/A

MIMO Device - 5725-580 MHz Band - FCC

Mode: n20

Max EIRP (mW): 1959.5

Frequency (MHz)	Chain	Software Setting	26dB BW (MHz)	Duty Cycle %	Power dBm	Total Power ¹ mW	dBm	FCC Limit dBm	Max Power (W)	Result
5745	0	19		96.5	16.1	189.3	22.8	27.0	0.246	Pass
	1				15.8					
	2				17.3					
	3				17.1					
5785	0	20		96.5	16.9	221.0	23.4	27.0		Pass
	1				16.7					
	2				17.6					
	3				17.8					
5825	0	20		96.5	17.6	246.1	23.9	27.0		Pass
	1				17.1					
	2				17.8					
	3				18.3					

MIMO Device 5725-5850 PSD - FCC

Mode: n20

Frequency (MHz)	Chain	Software Setting	99% BW (MHz)	Duty Cycle %	PSD dBm/MHz	Total PSD ¹ mW/MHz	dBm/MHz	FCC Limit dBm/500kHz	IC Limit	Result
5745	0	19	18.1	96.5	2.9	9.0	9.5	27.0	-	Pass
	1				2.5					
	2				4.0					
	3				3.9					
5785	0	20	18.1	96.5	3.8	10.8	10.3	27.0	-	Pass
	1				3.7					
	2				4.5					
	3				4.6					
5825	0	20	18.1	96.5	4.4	11.8	10.7	27.0	-	Pass
	1				4.1					
	2				4.7					
	3				5.0					

Client: Vivint Wireless	Job Number: J96091
Model: 1520 (4x4 5GHz 802.11 Client)	T-Log Number: T96173
	Project Manager: Irene Rademacher
Contact: Venkat Kalkunte	Project Coordinator: -
Standard: FCC 15.B / 15.407 (New Rules)	Class: N/A

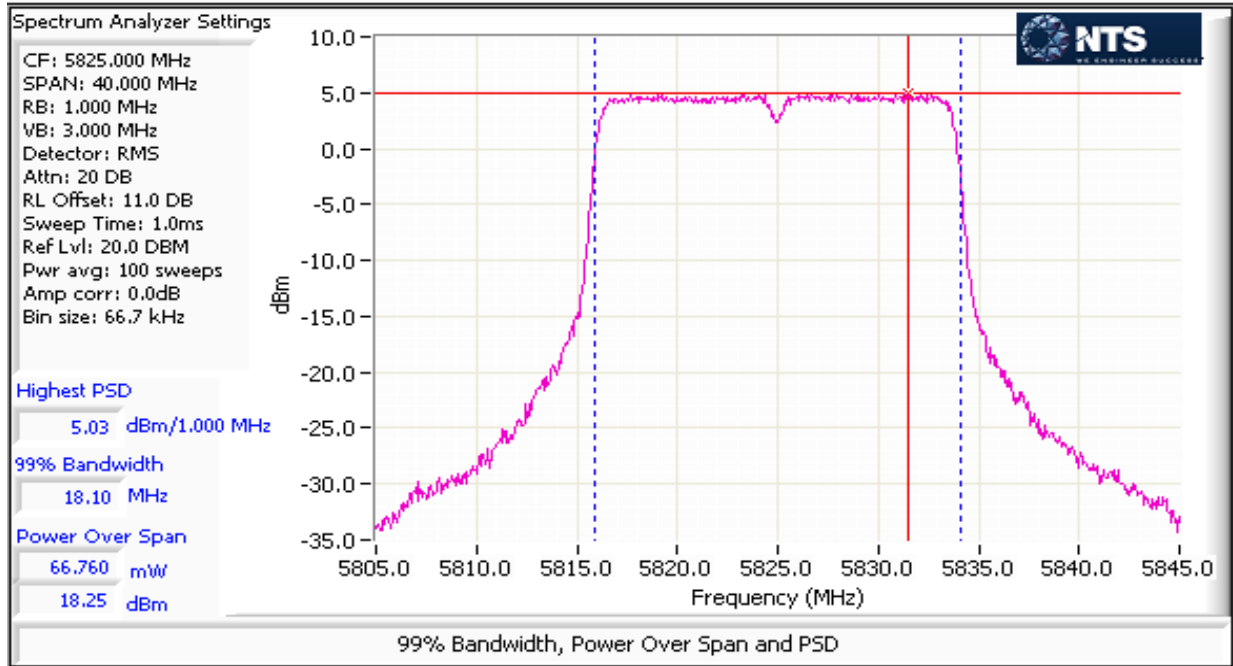



EMC Test Data

Client: Vivint Wireless	Job Number: J96091
Model: 1520 (4x4 5GHz 802.11 Client)	T-Log Number: T96173
	Project Manager: Irene Rademacher
Contact: Venkat Kalkunte	Project Coordinator: -
Standard: FCC 15.B / 15.407 (New Rules)	Class: N/A

Run #2: Bandwidth Measurements
 Date of Test: 11/3/2014 0:00
 Test Engineer: Jack Liu
 Test Location: FT Lab #4B
 Config. Used: 1
 Config Change: None
 EUT Voltage: POE

Mode: HT20
 5725-5850MHz band (UNII3)
 Testing performed on port: 0

Power Setting	Frequency (MHz)	Bandwidth (MHz)		RBW Setting (MHz)	
		6dB	99%	6dB	99%
19	5745	17.6	18.1	0.1	1
20	5785	17.6	18.1	0.1	1
20	5825	17.6	18.1	0.1	1

Note 1: 6dB BW: RBW=100kHz, VBW ≥ 3*RBW, peak detector, max hold, auto sweep time.
 99% BW: RBW=1.5% of of 99%BW, VBW ≥ 3*RBW, peak detector, max hold, auto sweep time.

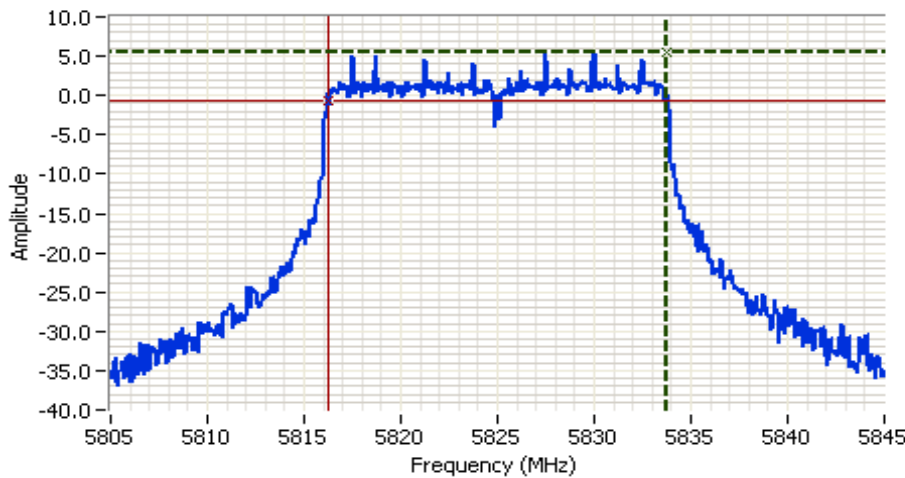

Analyzer Settings
 Agilent Technologies, E4446A
 CF: 5825.000 MHz
 SPAN: 40.000 MHz
 RB: 100 kHz
 VB: 300 kHz
 Detector: POS
 Attn: 20 DB
 RL Offset: 11.0 DB
 Sweep Time: 3.8ms
 Ref Lvl: 20.0 DBM

Comments
 6dB BW: 17.600 MHz
 802.11 n20

Cursor 1 5833.8000 5.43
 Cursor 2 5816.2000 -0.57

Delta Freq. 17.600
 Delta Amplitude 6.00



Client: Vivint Wireless	Job Number: J96091
Model: 1520 (4x4 5GHz 802.11 Client)	T-Log Number: T96173
	Project Manager: Irene Rademacher
Contact: Venkat Kalkunte	Project Coordinator: -
Standard: FCC 15.B / 15.407 (New Rules)	Class: N/A

RSS-210 (LELAN) and FCC 15.407(UNII) Antenna Port Measurements

Power, PSD, Peak Excursion, Bandwidth and Spurious Emissions

Test Specific Details

Objective: The objective of this test session is to perform final qualification testing of the EUT with respect to the specification listed above.

Summary of Results

Run #	Test Performed	Limit	Pass / Fail	Result / Margin
1	Power, 5150 - 5250MHz	15.407(a) (1)	Pass	n40: 20.7dBm (118.3 mW)
1	PSD, 5150 - 5250MHz	15.407(a) (1)	Pass	n40: 4.6 dBm/MHz
1	Power, 5250 - 5350MHz	15.407(a) (2)	Pass	n40: 20.9dBm (124.0 mW)
1	PSD, 5250 - 5350MHz	15.407(a) (2)	Pass	n40: 4.8 dBm/MHz
1	Max EIRP 5250 - 5350MHz	TPC required if EIRP ≥ 500mW (27dBm). EIRP ≥ 200mW (23dBm) DFS threshold = -64dBm.	Pass	EIRP = 29.9 dBm (987.2 mW)
1	Power, 5470 - 5725MHz	15.407(a) (2)	Pass	n40: 20.8dBm (119.9 mW)
1	PSD, 5470 - 5725MHz	15.407(a) (2)	Pass	n40: 5.2 dBm/MHz
1	Max EIRP 5470 - 5725MHz	TPC required if EIRP ≥ 500mW (27dBm). EIRP ≥ 200mW (23dBm) DFS threshold	Pass	EIRP = 29.8 dBm (947.8 mW)
1	Power, 5725 - 5850MHz	15.407(a) (3)	Pass	n40: 24.1dBm (260 mW)
1	PSD, 5725 - 5850MHz	15.407(a) (3)	Pass	n40: 8.0 dBm/MHz
2	26dB Bandwidth	15.407(h)(2)	N/A	n40: 41.5MHz minimum
2	Minimum 6dB Bandwidth for UNII3 band	15.407(e)	Pass	36.27 MHz



EMC Test Data

Client: Vivint Wireless	Job Number: J96091
Model: 1520 (4x4 5GHz 802.11 Client)	T-Log Number: T96173
	Project Manager: Irene Rademacher
Contact: Venkat Kalkunte	Project Coordinator: -
Standard: FCC 15.B / 15.407 (New Rules)	Class: N/A

General Test Configuration

When measuring the conducted emissions from the EUT's antenna port, the antenna port of the EUT was connected to the spectrum analyzer or power meter via a suitable attenuator to prevent overloading the measurement system. All measurements are corrected to allow for the external attenuators and cables used.

Ambient Conditions:

Temperature: 20.8 °C
 Rel. Humidity: 40 %

Modifications Made During Testing

No modifications were made to the EUT during testing

Deviations From The Standard

No deviations were made from the requirements of the standard.

Procedure Comments:

Measurements performed in accordance with FCC KDB 789033

Mode	Data Rate	Duty Cycle (x)	Constant DC?	T (ms)	Pwr Cor Factor*	Lin Volt Cor Factor**	Min VBW for FS (Hz)
n40	13.5	94.3%	yes	1.27	0.26	0.51	787

Sample Notes

Sample S/N: Prototype

Driver: -



EMC Test Data

Client: Vivint Wireless	Job Number: J96091
Model: 1520 (4x4 5GHz 802.11 Client)	T-Log Number: T96173
	Project Manager: Irene Rademacher
Contact: Venkat Kalkunte	Project Coordinator: -
Standard: FCC 15.B / 15.407 (New Rules)	Class: N/A

Antenna Gain Information

Freq	Antenna Gain (dBi) / Chain				BF	MultiChain Legacy	CDD	Sectorized / Xpol	Dir G (PWR)	Dir G (PSD)
	1	2	3	4						
5150-5250	6	6	6	6	Yes	No	Yes	No	9.0	9.0
5250-5350	6	6	6	6	Yes	No	Yes	No	9.0	9.0
5470-5725	6	6	6	6	Yes	No	Yes	No	9.0	9.0
5725-5850	6	6	6	6	Yes	No	Yes	No	9.0	9.0

For devices that support CDD modes

Min # of spatial streams: 2 MCS8 is the lowest rate supported
 Max # of spatial streams: 4

Notes:	BF = beamforming mode supported, Multichain Legacy = 802.11 legacy data rates supported for multichain transmissions, CDD = Cyclic Delay Diversity (or Cyclic Shift Diversity) modes supported, Sectorized / Xpol = antennas are sectorized or cross polarized.
Notes:	Dir G (PWR) = total gain (Gant + Array Gain) for power calculations; GA (PSD) = total gain for PSD calculations based on FCC KDB 662911. Depending on the modes supported, the Array Gain value for power could be different from the PSD value.
Notes:	Array gain for power/psd calculated per DKB 662911. Spatial Multiplexing with Nant=4, Nss=2, for worse case condition. Array gain = $10 \cdot \log(4/2) = 3\text{dB}$.

Note:

- Antenna port number defined
 Port JE09 -Test port 0 ; Port JE10 -Test port 1 ; Port JE11 -Test port 2 ; Port JE12 -Test port 3
- All the measurements measured at the end of the internal cable, not the output on the PCB board.



EMC Test Data

Client: Vivint Wireless	Job Number: J96091
Model: 1520 (4x4 5GHz 802.11 Client)	T-Log Number: T96173
	Project Manager: Irene Rademacher
Contact: Venkat Kalkunte	Project Coordinator: -
Standard: FCC 15.B / 15.407 (New Rules)	Class: N/A

MIMO Device - 5150-5250 MHz Band - FCC

Mode: n40

Max EIRP (mW): 941.5

Frequency (MHz)	Chain	Software Setting	26dB BW (MHz)	Duty Cycle %	Power ¹ dBm	Total Power mW	Total Power dBm	FCC Limit dBm	Max Power (W)	Result
5190	0	14	41.33	94.3	12.3	72.2	18.6	21.0	0.118	Pass
	1				11.7					
	2				13.0					
	3				12.2					
5230	0	16	42.53	94.3	14.3	118.3	20.7	21.0		
	1				14.4					
	2				14.7					
	3				14.5					

5150-5250 PSD - FCC

Mode: n40

Frequency (MHz)	Chain	Software Setting	99% BW (MHz)	Duty Cycle %	PSD dBm/MHz	Total PSD ¹ mW/MHz	Total PSD ¹ dBm/MHz	FCC Limit dBm/MHz	IC Limit dBm/MHz	Result
5190	0	14	36.47	94.3	-3.7	1.8	2.6	8.0	-	Pass
	1				-4.3					
	2				-2.9					
	3				-3.8					
5230	0	16	36.47	94.3	-1.8	2.9	4.6	8.0	-	Pass
	1				-1.7					
	2				-1.4					
	3				-1.7					

Client: Vivint Wireless	Job Number: J96091
Model: 1520 (4x4 5GHz 802.11 Client)	T-Log Number: T96173
	Project Manager: Irene Rademacher
Contact: Venkat Kalkunte	Project Coordinator: -
Standard: FCC 15.B / 15.407 (New Rules)	Class: N/A

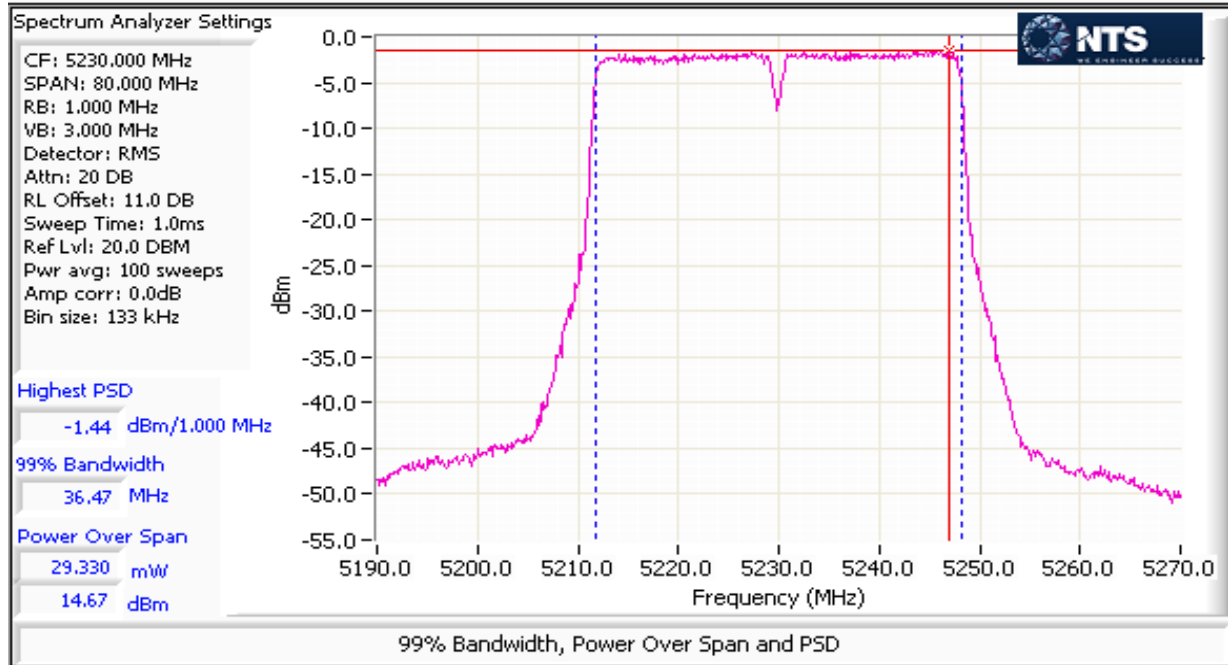



EMC Test Data

Client: Vivint Wireless	Job Number: J96091
Model: 1520 (4x4 5GHz 802.11 Client)	T-Log Number: T96173
	Project Manager: Irene Rademacher
Contact: Venkat Kalkunte	Project Coordinator: -
Standard: FCC 15.B / 15.407 (New Rules)	Class: N/A

MIMO Device - 5250-5350 MHz Band - FCC

Mode: n40

Max EIRP (mW): 987.2

Frequency (MHz)	Chain	Software Setting	26dB BW (MHz)	Duty Cycle %	Power dBm	Total Power ¹ mW	dBm	FCC Limit dBm	Max Power (W)	Result
5270	0	16	42.53	94.3	14.5	124.0	20.9	21.0	0.124	Pass
	1				14.5					
	2				14.8					
	3				14.9					
5310	0	15	41.47	94.3	13.9	98.1	19.9	21.0		
	1				13.5					
	2				13.4					
	3				13.8					

MIMO Device 5250-5350 PSD - FCC

Mode: n40

Frequency (MHz)	Chain	Software Setting	99% BW (MHz)	Duty Cycle %	PSD dBm/MHz	Total PSD ¹ mW/MHz	dBm/MHz	FCC Limit dBm/MHz	IC Limit dBm/MHz	Result
5270	0	16	36.47	94.3	-1.6	3.0	4.8	8.0	-	Pass
	1				-1.7					
	2				-1.5					
	3				-1.0					
5310	0	15	36.47	94.3	-2.3	2.3	3.7	8.0	-	Pass
	1				-2.7					
	2				-2.8					
	3				-2.5					

Client: Vivint Wireless	Job Number: J96091
Model: 1520 (4x4 5GHz 802.11 Client)	T-Log Number: T96173
Contact: Venkat Kalkunte	Project Manager: Irene Rademacher
Standard: FCC 15.B / 15.407 (New Rules)	Project Coordinator: -
	Class: N/A

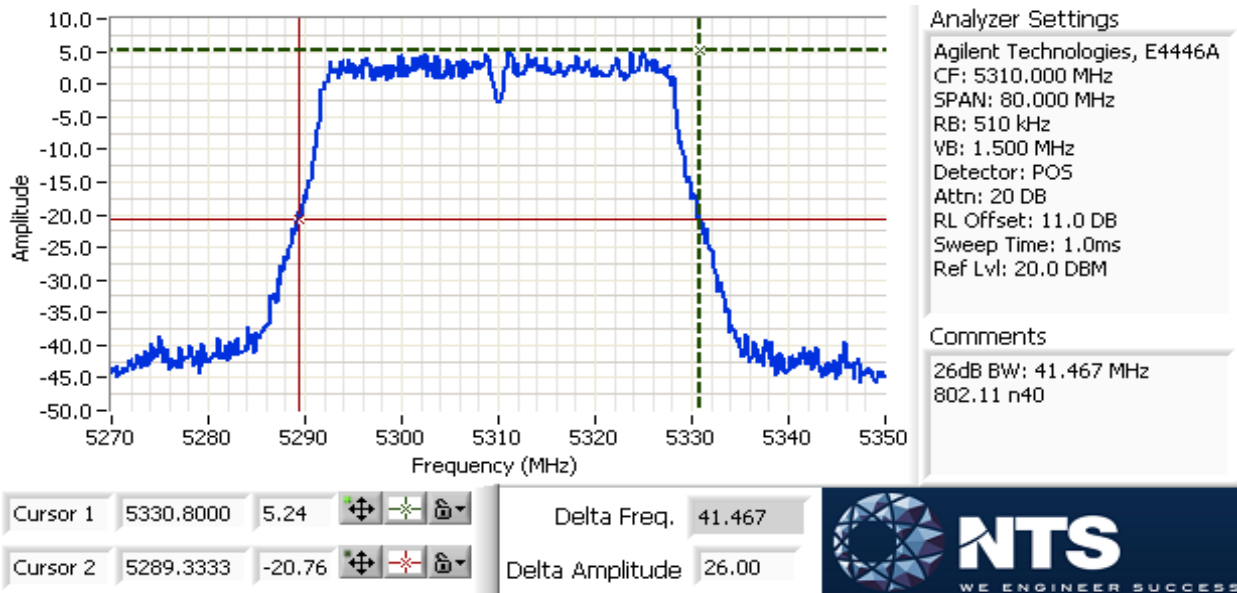
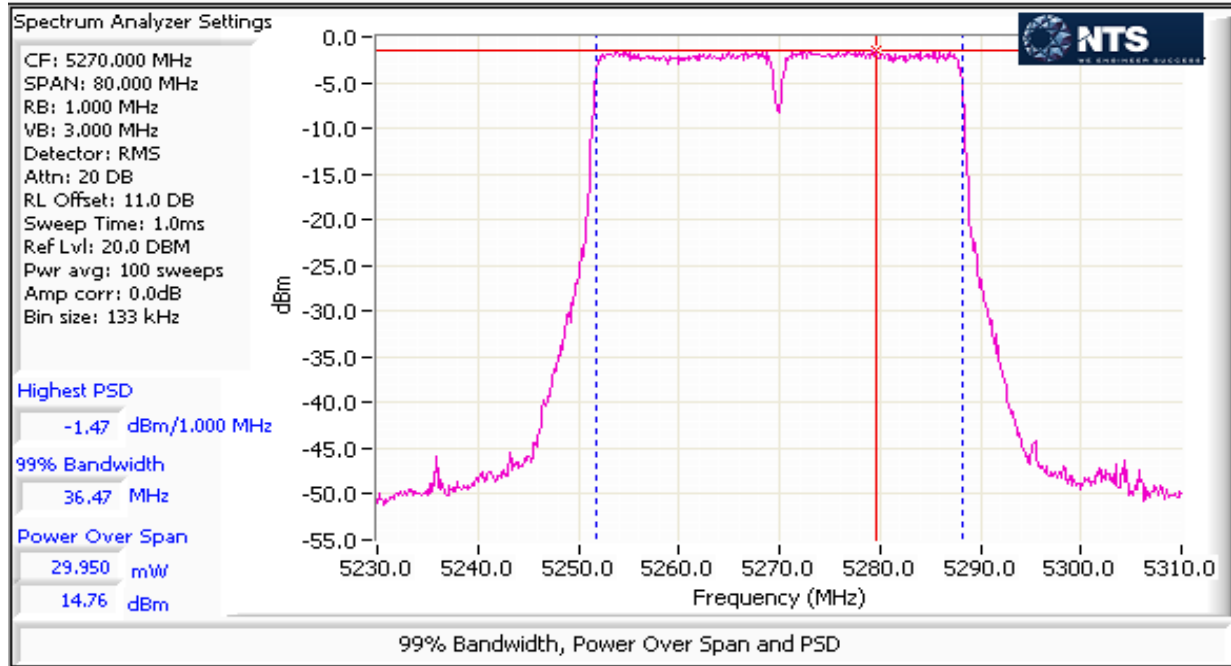



EMC Test Data

Client: Vivint Wireless	Job Number: J96091
Model: 1520 (4x4 5GHz 802.11 Client)	T-Log Number: T96173
	Project Manager: Irene Rademacher
Contact: Venkat Kalkunte	Project Coordinator: -
Standard: FCC 15.B / 15.407 (New Rules)	Class: N/A

MIMO Device - 5470-5725 MHz Band - FCC

Mode: n40

Max EIRP (mW): 947.8

Frequency (MHz)	Chain	Software Setting	26dB BW (MHz)	Duty Cycle %	Power dBm	Total Power ¹ mW	FCC Limit dBm	Max Power (W)	Result	
5510	0	15	41.73	94.3	12.8	94.3	19.7	0.119	Pass	
	1				13.2					
	2				14.1					
	3				13.7					
5550	0	16	42.00	94.3	14.1	117.8	20.7		21.0	Pass
	1				14.0					
	2				15.3					
	3				14.2					
5670	0	17	42.27	94.3	14.0	119.9	20.8		21.0	Pass
	1				14.1					
	2				15.5					
	3				14.3					
802.11ac 40MHz UNII-2ext										
5710	0	17	36.01	94.3	14.0	119.0	20.8	21.0	Pass	
	1				13.5					
	2				15.3					
	3				15.0					
UNII-3										
5710	0	17	6.07	94.3	4.7	13.1	11.2	15.8	Pass	
	1				3.9					
	2				5.5					
	3				5.4					



EMC Test Data

Client: Vivint Wireless	Job Number: J96091
Model: 1520 (4x4 5GHz 802.11 Client)	T-Log Number: T96173
	Project Manager: Irene Rademacher
Contact: Venkat Kalkunte	Project Coordinator: -
Standard: FCC 15.B / 15.407 (New Rules)	Class: N/A

MIMO Device 5470-5725 PSD - FCC
Mode: n40

Frequency (MHz)	Chain	Software Setting	99% BW (MHz)	Duty Cycle %	PSD dBm/MHz	Total PSD ¹ mW/MHz	Total PSD ¹ dBm/MHz	FCC Limit dBm/MHz	IC Limit dBm/MHz	Result
5510	0	15	36.47	94.3	-3.3	2.3	3.6	8.0	-	Pass
	1				-3.0					
	2				-1.9					
	3				-2.6					
5550	0	16	36.47	94.3	-2.0	2.8	4.5	8.0	-	Pass
	1				-2.3					
	2				-0.9					
	3				-2.0					
5670	0	17	36.47	94.3	-2.1	2.9	4.7	8.0	-	Pass
	1				-1.9					
	2				-0.8					
	3				-1.7					

802.11ac 40MHz

UNII-2ext

5710	0	17	33.22	94.3	-1.6	3.3	5.1	8.0	-	Pass
	1				-2.1					
	2				-0.6					
	3				-0.6					

UNII-3

5710	0	17	3.91	94.3	-1.3	3.3	5.2	8.0	-	Pass
	1				-2.1					
	2				-0.6					
	3				-0.4					

Client: Vivint Wireless	Job Number: J96091
Model: 1520 (4x4 5GHz 802.11 Client)	T-Log Number: T96173
	Project Manager: Irene Rademacher
Contact: Venkat Kalkunte	Project Coordinator: -
Standard: FCC 15.B / 15.407 (New Rules)	Class: N/A

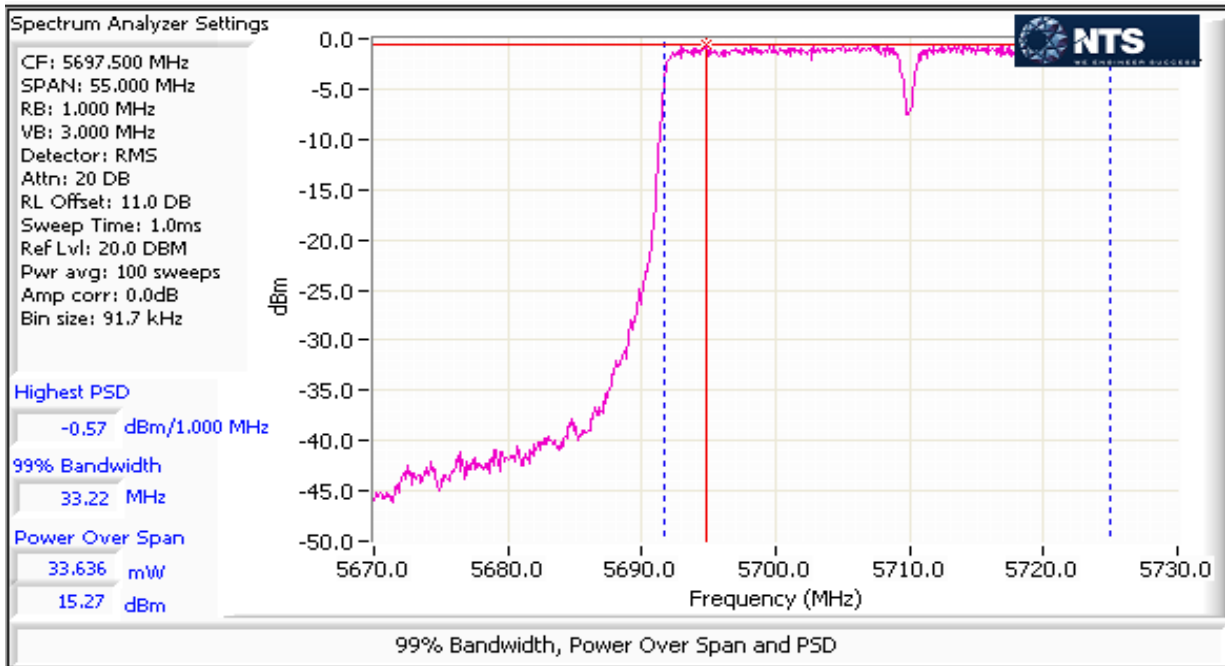
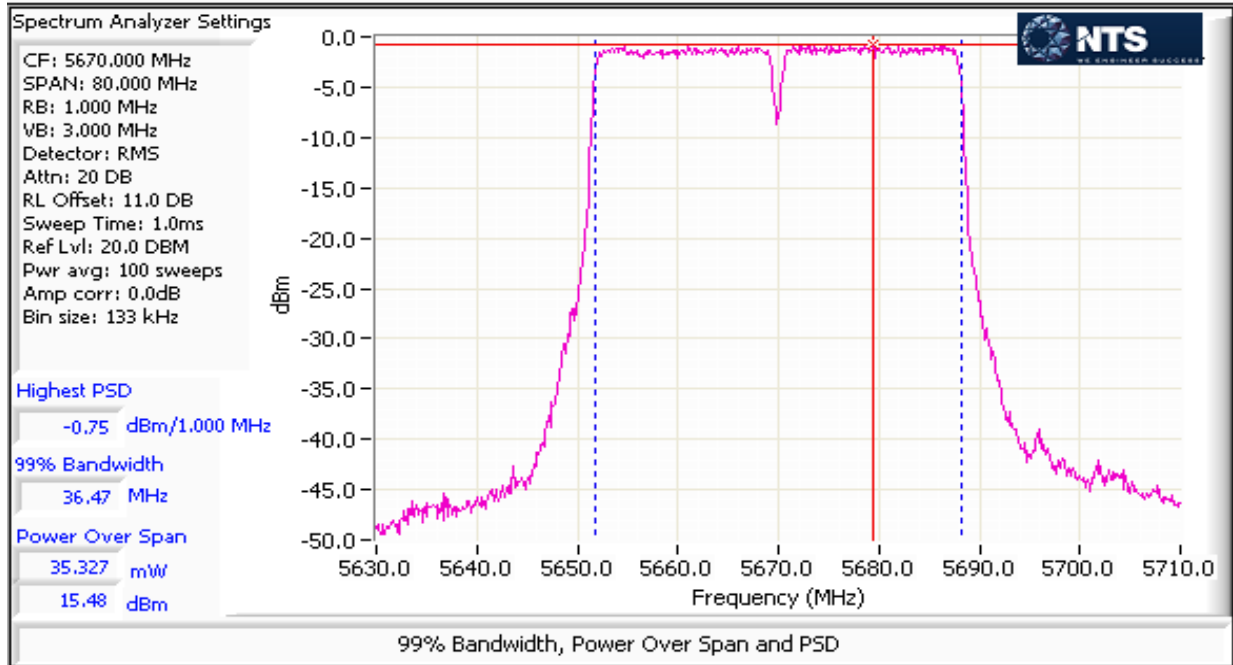

Client: Vivint Wireless	Job Number: J96091
Model: 1520 (4x4 5GHz 802.11 Client)	T-Log Number: T96173
	Project Manager: Irene Rademacher
Contact: Venkat Kalkunte	Project Coordinator: -
Standard: FCC 15.B / 15.407 (New Rules)	Class: N/A

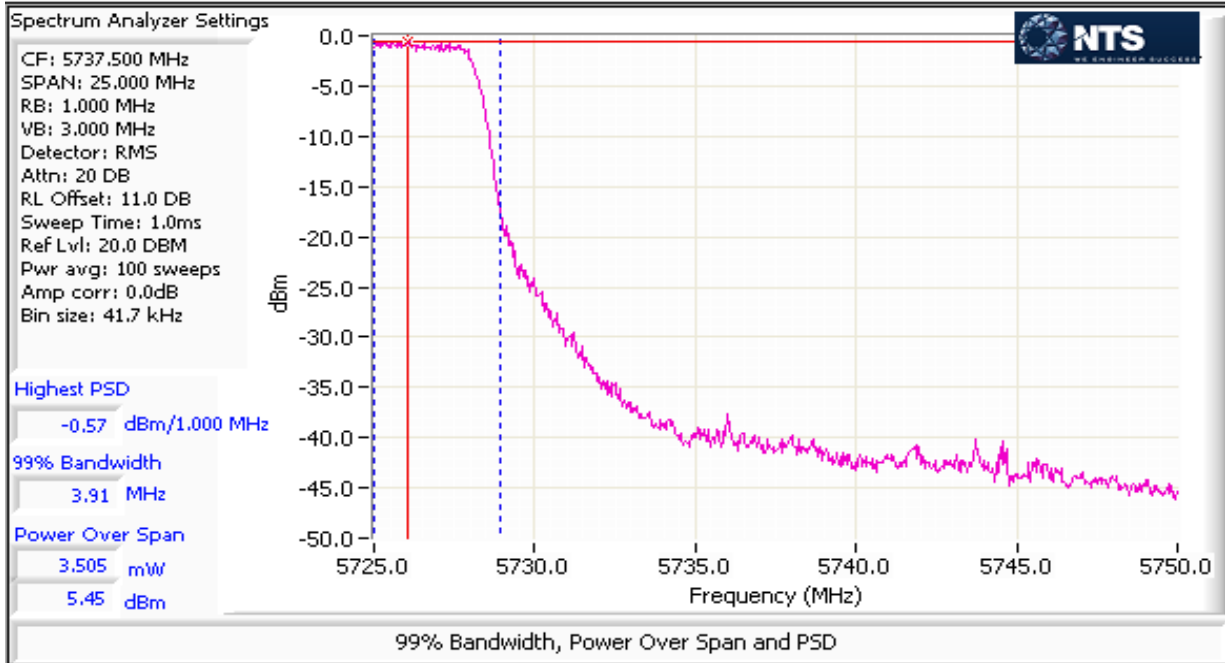



EMC Test Data

Client: Vivint Wireless	Job Number: J96091
Model: 1520 (4x4 5GHz 802.11 Client)	T-Log Number: T96173
	Project Manager: Irene Rademacher
Contact: Venkat Kalkunte	Project Coordinator: -
Standard: FCC 15.B / 15.407 (New Rules)	Class: N/A

MIMO Device - 5725-580 MHz Band - FCC

Mode: n40

Max EIRP (mW): 2068.4

Frequency (MHz)	Chain	Software Setting	26dB BW (MHz)	Duty Cycle %	Power dBm	Total Power ¹ mW	dBm	FCC Limit dBm	Max Power (W)	Result
5755	0	16		94.3	14.1	113.4	20.5	27.0	0.260	Pass
	1				13.2					
	2				14.8					
	3				14.8					
5795	0	20		94.3	17.7	259.8	24.1	27.0		Pass
	1				17.2					
	2				18.1					
	3				18.4					

MIMO Device 5725-5850 PSD - FCC

Mode: n40

Frequency (MHz)	Chain	Software Setting	99% BW (MHz)	Duty Cycle %	PSD dBm/MHz	Total PSD ¹ mW/MHz	dBm/MHz	FCC Limit dBm/500kHz	IC Limit	Result
5755	0	16	36.47	94.3	-2.1	2.8	4.4	27.0	-	Pass
	1				-2.9					
	2				-1.4					
	3				-1.3					
5795	0	20	36.47	94.3	1.4	6.3	8.0	27.0	-	Pass
	1				1.0					
	2				2.0					
	3				2.2					

Client: Vivint Wireless	Job Number: J96091
Model: 1520 (4x4 5GHz 802.11 Client)	T-Log Number: T96173
	Project Manager: Irene Rademacher
Contact: Venkat Kalkunte	Project Coordinator: -
Standard: FCC 15.B / 15.407 (New Rules)	Class: N/A

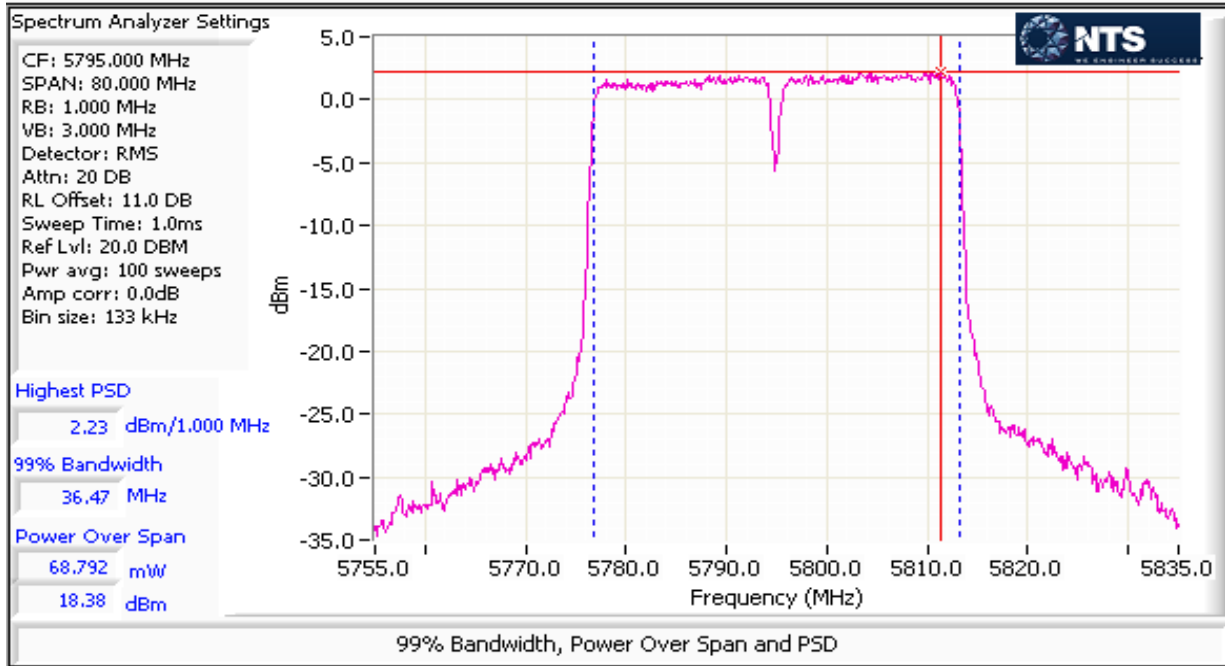

Client: Vivint Wireless	Job Number: J96091
Model: 1520 (4x4 5GHz 802.11 Client)	T-Log Number: T96173
	Project Manager: Irene Rademacher
Contact: Venkat Kalkunte	Project Coordinator: -
Standard: FCC 15.B / 15.407 (New Rules)	Class: N/A

Run #2: Bandwidth Measurements
 Date of Test: 11/3/2014 0:00 Config. Used: 1
 Test Engineer: Jack Liu Config Change: None
 Test Location: FT Lab #4B EUT Voltage: POE

Mode: HT40
 5725-5850MHz band (UNII3)
 Testing performed on port: 0

Power Setting	Frequency (MHz)	Bandwidth (MHz)		RBW Setting (MHz)	
		6dB	99%	6dB	99%
16	5755	36.27	36.47	0.1	1
20	5795	36.27	36.47	0.1	1

Note 1: 6dB BW: RBW=100kHz, VBW ≥ 3*RBW, peak detector, max hold, auto sweep time.
 99% BW: RBW=1-5% of of 99%BW, VBW ≥ 3*RBW, peak detector, max hold, auto sweep time.

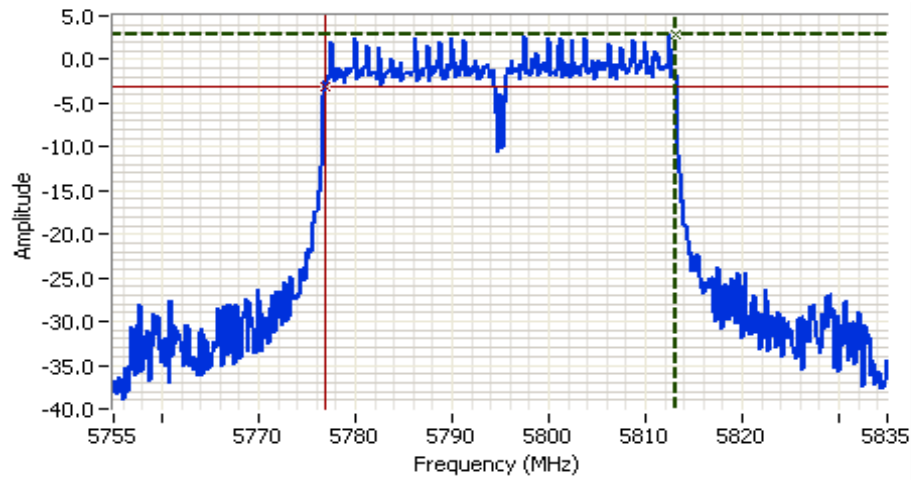

Analyzer Settings
 Agilent Technologies, E4446A
 CF: 5795.000 MHz
 SPAN: 80.000 MHz
 RB: 100 kHz
 VB: 300 kHz
 Detector: POS
 Attn: 20 DB
 RL Offset: 11.0 DB
 Sweep Time: 7.7ms
 Ref Lvl: 20.0 DBM

Comments
 6dB BW: 36.267 MHz
 802.11 n40

Cursor 1 5813.1333 2.86 Delta Freq. 36.267
 Cursor 2 5776.8667 -3.14 Delta Amplitude 6.00



EMC Test Data

Client:	Vivint Wireless	Job Number:	J96091
Model:	1520 (4x4 5GHz 802.11 Client)	T-Log Number:	T96173
		Project Manager:	Irene Rademacher
Contact:	Venkat Kalkunte	Project Coordinator:	-
Standard:	FCC 15.B / 15.407 (New Rules)	Class:	N/A

RSS-210 (LELAN) and FCC 15.407(UNII) Antenna Port Measurements Power, PSD, Peak Excursion, Bandwidth and Spurious Emissions

Test Specific Details

Objective: The objective of this test session is to perform final qualification testing of the EUT with respect to the specification listed above.

Summary of Results

Run #	Test Performed	Limit	Pass / Fail	Result / Margin
1	Power, 5150 - 5250MHz	15.407(a) (1)	Pass	ac80: 15.4dBm (34.8 mW)
1	PSD, 5150 - 5250MHz	15.407(a) (1)	Pass	ac80: -3.0 dBm/MHz
1	Power, 5250 - 5350MHz	15.407(a) (2)	Pass	ac80: 17.9dBm (62.2 mW)
1	PSD, 5250 - 5350MHz	15.407(a) (2)	Pass	ac80: -0.1 dBm/MHz
1	Max EIRP 5250 - 5350MHz	TPC required if EIRP ≥ 500mW (27dBm). EIRP ≥ 200mW (23dBm) DFS threshold = -64dBm.	-	EIRP = 26.9 dBm (495.3 mW)
1	Power, 5470 - 5725MHz	15.407(a) (2)	Pass	ac80: 18.3dBm (67.4 mW)
1	PSD, 5470 - 5725MHz	15.407(a) (2)	Pass	ac80: 0.6 dBm/MHz
1	Max EIRP 5470 - 5725MHz	TPC required if EIRP ≥ 500mW (27dBm). EIRP ≥ 200mW (23dBm) DFS threshold	-	EIRP = 27.3 dBm (536.85 mW)
1	Power, 5725 - 5850MHz	15.407(a) (3)	Pass	ac80: 19.1dBm (81 mW)
1	PSD, 5725 - 5850MHz	15.407(a) (3)	Pass	ac80: 0.9 dBm/MHz



EMC Test Data

Client: Vivint Wireless	Job Number: J96091
Model: 1520 (4x4 5GHz 802.11 Client)	T-Log Number: T96173
	Project Manager: Irene Rademacher
Contact: Venkat Kalkunte	Project Coordinator: -
Standard: FCC 15.B / 15.407 (New Rules)	Class: N/A

Run #	Test Performed	Limit	Pass / Fail	Result / Margin
1	26dB Bandwidth	15.407 (Information only)	-	ac80: 80.97 MHz
2	Minimum 6dB Bandwidth for UNII3 band	15.407(e)	Pass	75.69 MHz

General Test Configuration

When measuring the conducted emissions from the EUT's antenna port, the antenna port of the EUT was connected to the spectrum analyzer or power meter via a suitable attenuator to prevent overloading the measurement system. All measurements are corrected to allow for the external attenuators and cables used.

Ambient Conditions:

Temperature: ??? °C
 Rel. Humidity: ??? %

Modifications Made During Testing

No modifications were made to the EUT during testing

Deviations From The Standard

No deviations were made from the requirements of the standard.

Procedure Comments:

Measurements performed in accordance with FCC KDB 789033 D01 v01r03, dated April 8, 2013

Mode	Data Rate	Duty Cycle (x)	Constant DC?	T (ms)	Pwr Cor Factor*	Lin Volt Cor Factor**	Min VBW for FS (Hz)
11ac80	MCS8	0.92	yes	0.58	0.36	0.72	1724

Sample Notes

Sample S/N: Prototype
 Driver: -



EMC Test Data

Client: Vivint Wireless	Job Number: J96091
Model: 1520 (4x4 5GHz 802.11 Client)	T-Log Number: T96173
	Project Manager: Irene Rademacher
Contact: Venkat Kalkunte	Project Coordinator: -
Standard: FCC 15.B / 15.407 (New Rules)	Class: N/A

Antenna Gain Information

Freq	Antenna Gain (dBi) / Chain				BF	MultiChain Legacy	CDD	Sectorized / Xpol	Dir G (PWR)	Dir G (PSD)
	1	2	3	4						
5150-5250	6	6	6	6	Yes	No	Yes	No	9.0	9.0
5250-5350	6	6	6	6	Yes	No	Yes	No	9.0	9.0
5470-5725	6	6	6	6	Yes	No	Yes	No	9.0	9.0
5725-5850	6	6	6	6	Yes	No	Yes	No	9.0	9.0

For devices that support CDD modes

Min # of spatial streams: 2 MCS8 is the lowest rate supported
 Max # of spatial streams: 4

Notes:	BF = beamforming mode supported, Multichain Legacy = 802.11 legacy data rates supported for multichain transmissions, CDD = Cyclic Delay Diversity (or Cyclic Shift Diversity) modes supported, Sectorized / Xpol = antennas are sectorized or cross polarized.
Notes:	Dir G (PWR) = total gain (Gant + Array Gain) for power calculations; GA (PSD) = total gain for PSD calculations based on FCC KDB 662911. Depending on the modes supported, the Array Gain value for power could be different from the PSD value.
Notes:	Array gain for power/psd calculated per DKB 662911 D01, v01r02. Spatial Multiplexing with Nant=4, Nss=2, for worse case condition. Array gain = $10 \cdot \log(4/2) = 3\text{dB}$.

Note:

1. Antenna port number defined

Port JE09 -Test port 0 ; Port JE10 -Test port 1 ; Port JE11 -Test port 2 ; Port JE12 -Test port 3

2. All the measurements measured at the end of the internal cable, not the output on the PCB board.

Tx Chain: 4x4
 Mode: AC80
 Data Rate: MCS 8
 Packet Size: 1000



EMC Test Data

Client: Vivint Wireless	Job Number: J96091
Model: 1520 (4x4 5GHz 802.11 Client)	T-Log Number: T96173
	Project Manager: Irene Rademacher
Contact: Venkat Kalkunte	Project Coordinator: -
Standard: FCC 15.B / 15.407 (New Rules)	Class: N/A

MIMO Device - 5150-5250 MHz Band - FCC
 Mode: ac80 Max EIRP (mW): 277.45446

Frequency (MHz)	Chain	Software Setting	26dB BW (MHz)	Duty Cycle %	Power ¹ dBm	Total Power mW	Total Power dBm	FCC Limit dBm	Max Power (W)	Result
5210	0	11	82.78	92	8.7	34.8	15.4	21.0	0.035	Pass
	1				9.0					
	2				9.4					
	3				9.0					

5150-5250 PSD - FCC
 Mode: ac80

Frequency (MHz)	Chain	Software Setting	99% BW (MHz)	Duty Cycle %	PSD dBm/MHz	Total PSD ¹ mW/MHz	Total PSD ¹ dBm/MHz	FCC Limit dBm/MHz	IC Limit dBm/MHz	Result
5210	0	11	75.61	92	-9.8	0.5	-3.0	8.0	-	Pass
	1				-9.4					
	2				-9.1					
	3				-9.4					

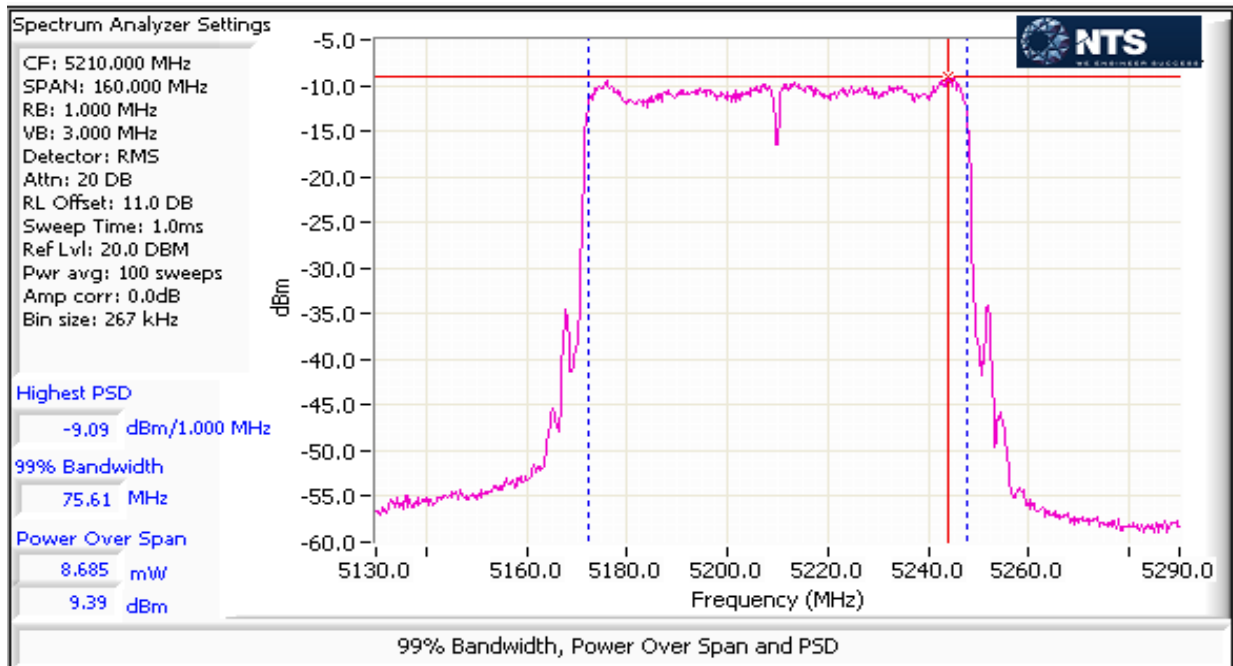



EMC Test Data

Client: Vivint Wireless	Job Number: J96091
Model: 1520 (4x4 5GHz 802.11 Client)	T-Log Number: T96173
Contact: Venkat Kalkunte	Project Manager: Irene Rademacher
Standard: FCC 15.B / 15.407 (New Rules)	Project Coordinator: -
	Class: N/A

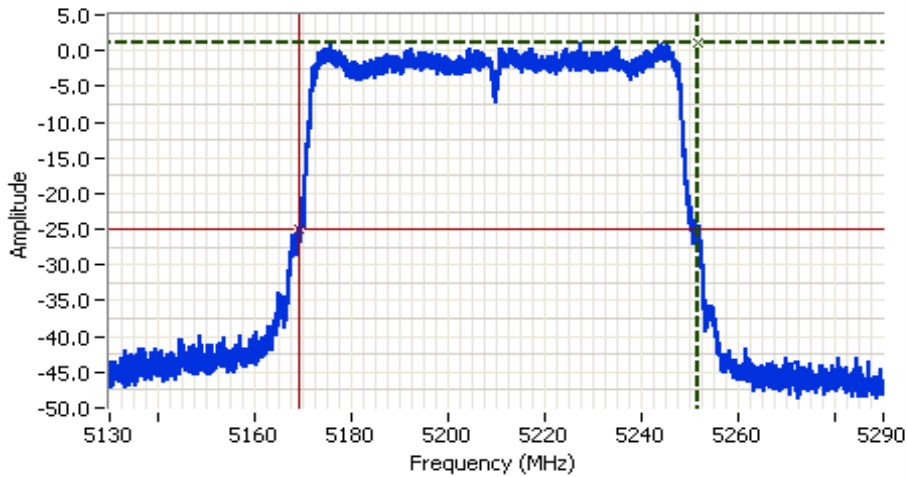

Analyzer Settings

Agilent Technologies, E4446A
 CF: 5210.000 MHz
 SPAN: 160.000 MHz
 RB: 1.000 MHz
 VB: 3.000 MHz
 Detector: POS
 Attn: 20 DB
 RL Offset: 11.0 DB
 Sweep Time: 1.1ms
 Ref Lvl: 20.0 DBM

Comments

26dB BW: 82.784 MHz
 802.11 ac80

Cursor 1	5251.8508	1.02	
Cursor 2	5169.0673	-24.98	

Delta Freq.	82.784
Delta Amplitude	26.00





EMC Test Data

Client: Vivint Wireless	Job Number: J96091
Model: 1520 (4x4 5GHz 802.11 Client)	T-Log Number: T96173
	Project Manager: Irene Rademacher
Contact: Venkat Kalkunte	Project Coordinator: -
Standard: FCC 15.B / 15.407 (New Rules)	Class: N/A

MIMO Device - 5250-5350 MHz Band - FCC
 Mode: ac80 Max EIRP (mW): 495.3

Frequency (MHz)	Chain	Software Setting	26dB BW (MHz)	Duty Cycle %	Power dBm	Total Power ¹ mW	Total Power ¹ dBm	FCC Limit dBm	Max Power (W)	Result
5290	0	13	80.97	92	11.8	62.2	17.9	21.0	0.062	Pass
	1				11.7					
	2				11.3					
	3				11.5					

MIMO Device 5250-5350 PSD - FCC
 Mode: ac80

Frequency (MHz)	Chain	Software Setting	99% BW (MHz)	Duty Cycle %	PSD dBm/MHz	Total PSD ¹ mW/MHz	Total PSD ¹ dBm/MHz	FCC Limit dBm/MHz	IC Limit dBm/MHz	Result
5290	0	13	75.61	92	-6.4	1.0	-0.1	8.0	-	Pass
	1				-6.6					
	2				-7.0					
	3				-6.1					

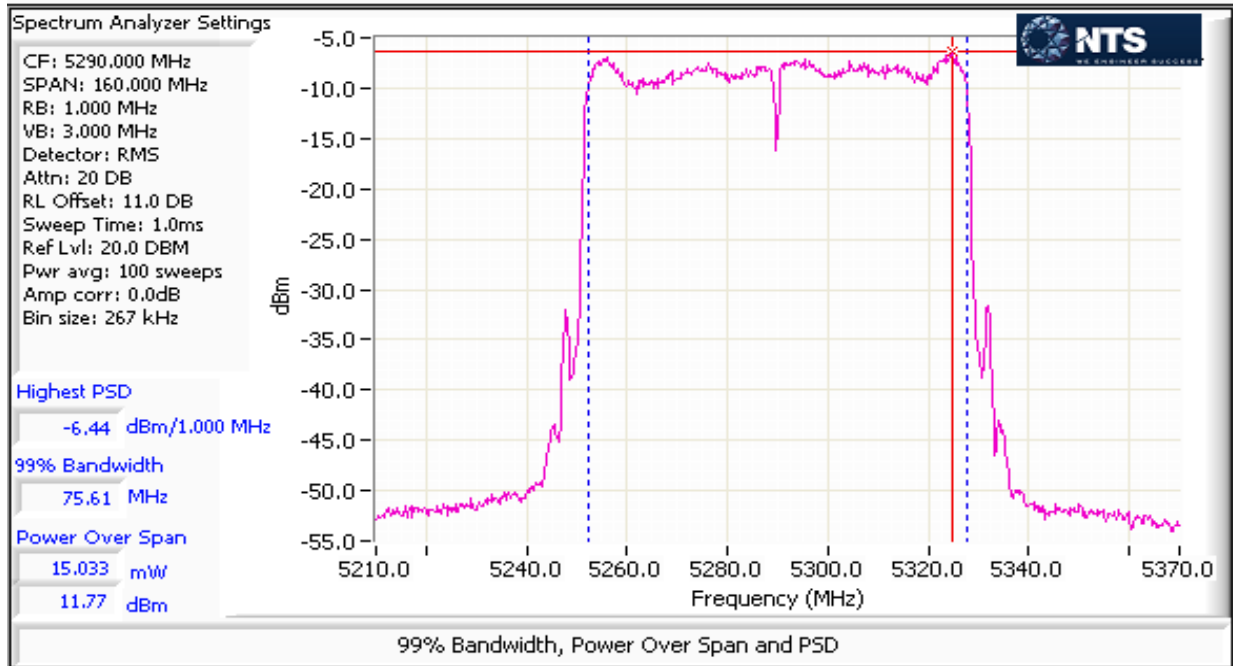



EMC Test Data

Client: Vivint Wireless	Job Number: J96091
Model: 1520 (4x4 5GHz 802.11 Client)	T-Log Number: T96173
	Project Manager: Irene Rademacher
Contact: Venkat Kalkunte	Project Coordinator: -
Standard: FCC 15.B / 15.407 (New Rules)	Class: N/A

MIMO Device - 5470-5725 MHz Band - FCC											
Mode: ac80		Max EIRP (mW): 536.85									
Frequency (MHz)	Chain	Software Setting	26dB BW (MHz)	Duty Cycle %	Power dBm	Total Power ¹		FCC Limit dBm	Max Power (W)	Result	
						mW	dBm				
5530	0	12	82.30	92	9.7	39.9	16.0	21.0	0.067	Pass	
	1				9.3						
	2				9.7						
	3				9.9						
5610	0	14	82.22	92	12.0	67.4	18.3	21.0		Pass	
	1				11.5						
	2				12.2						
	3				11.9						
802.11ac 80MHz UNII-2ext											
5690	0	14	75.33	92	11.4	65.5	18.2	21.0		Pass	
	1				11.9						
	2				12.5						
	3				11.3						
UNII-3											
5690	0	14	6.68	92	-1.7	3.2	5.0	16.2	Pass		
	1				-1.3						
	2				-0.8						
	3				-1.7						



EMC Test Data

Client: Vivint Wireless	Job Number: J96091
Model: 1520 (4x4 5GHz 802.11 Client)	T-Log Number: T96173
	Project Manager: Irene Rademacher
Contact: Venkat Kalkunte	Project Coordinator: -
Standard: FCC 15.B / 15.407 (New Rules)	Class: N/A

MIMO Device 5470-5725 PSD - FCC
Mode: ac80

Frequency (MHz)	Chain	Software Setting	99% BW (MHz)	Duty Cycle %	PSD dBm/MHz	Total PSD ¹ mW/MHz	Total PSD ¹ dBm/MHz	FCC Limit dBm/MHz	IC Limit dBm/MHz	Result
5530	0	12	75.61	92	-8.6	0.6	-2.3	8.0	-	Pass
	1				-9.4					
	2				-8.4					
	3				-8.4					
5610	0	14	75.61	92	-6.3	1.1	0.3	8.0	-	Pass
	1				-6.5					
	2				-5.6					
	3				-6.1					

802.11ac 80MHz

UNII-2ext

5690	0	14	72.71	92	-6.0	1.1	0.6	8.0	-	Pass
	1				-5.7					
	2				-5.6					
	3				-5.9					

UNII-3

5690	0	14	3.77	92	-6.8	1.0	0.1	8.0	-	Pass
	1				-6.4					
	2				-5.4					
	3				-6.5					

Client: Vivint Wireless	Job Number: J96091
Model: 1520 (4x4 5GHz 802.11 Client)	T-Log Number: T96173
Contact: Venkat Kalkunte	Project Manager: Irene Rademacher
Standard: FCC 15.B / 15.407 (New Rules)	Project Coordinator: -
	Class: N/A

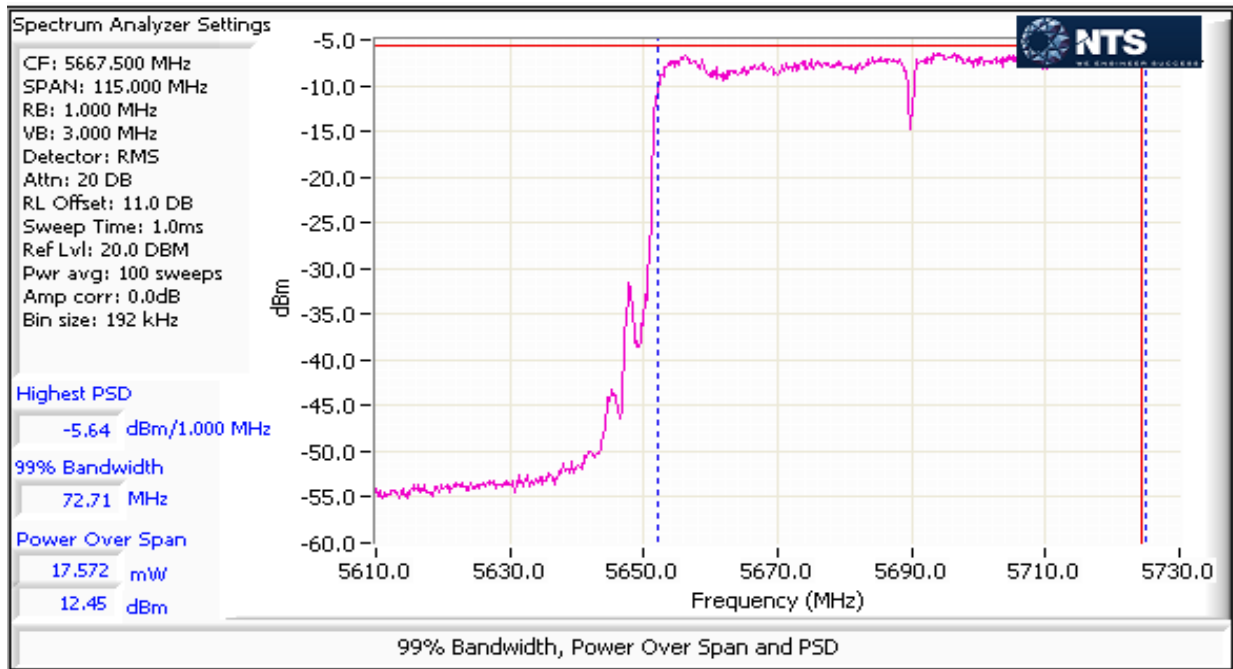
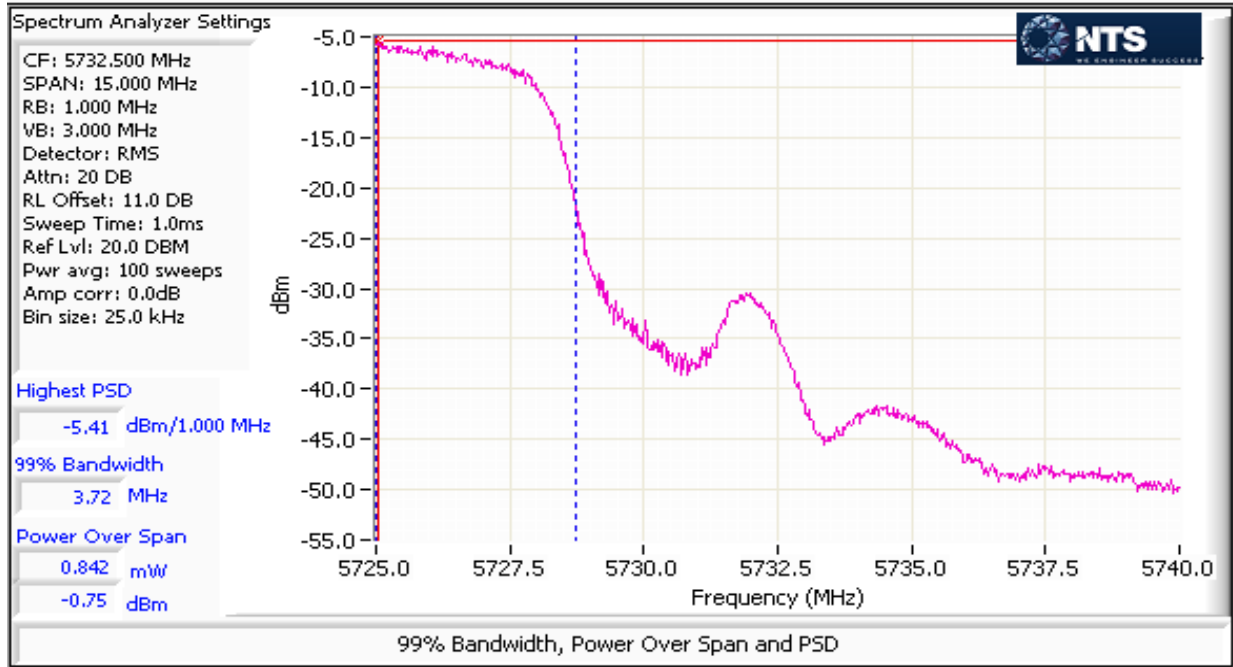



EMC Test Data

Client: Vivint Wireless	Job Number: J96091
Model: 1520 (4x4 5GHz 802.11 Client)	T-Log Number: T96173
	Project Manager: Irene Rademacher
Contact: Venkat Kalkunte	Project Coordinator: -
Standard: FCC 15.B / 15.407 (New Rules)	Class: N/A

MIMO Device - 5725-580 MHz Band - FCC

Mode: ac80

Max EIRP (mW): 645.30932

Frequency (MHz)	Chain	Software Setting	26dB BW (MHz)	Duty Cycle %	Power dBm	Total Power ¹ mW	Total Power ¹ dBm	FCC Limit dBm	Max Power (W)	Result
5775	0	14		92	12.3	81.0	19.1	27.0	0.081	Pass
	1				12.3					
	2				13.3					
	3				12.7					

MIMO Device 5725-5850 PSD - FCC

Mode: ac80

Frequency (MHz)	Chain	Software Setting	99% BW (MHz)	Duty Cycle %	PSD dBm/MHz	Total PSD ¹ mW/MHz	Total PSD ¹ dBm/MHz	FCC Limit dBm/500kHz	IC Limit	Result
5775	0	14	75.61	92	-5.8	1.2	0.9	27.0	-	Pass
	1				-5.9					
	2				-5.0					
	3				-5.5					

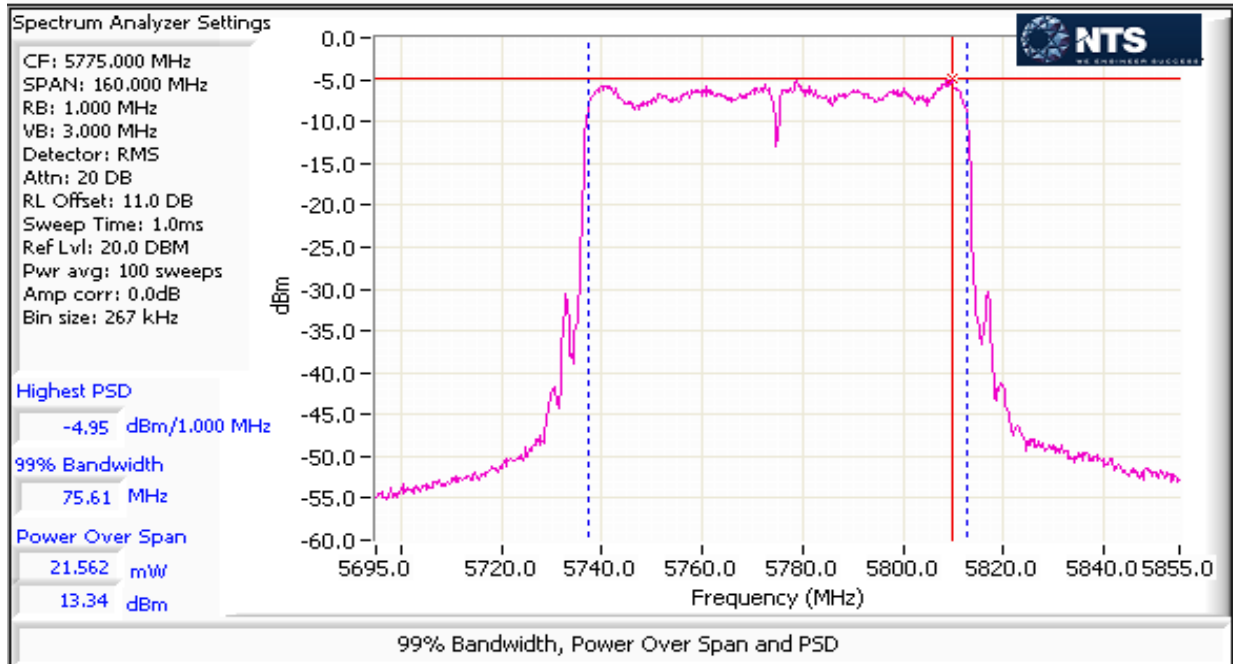



EMC Test Data

Client: Vivint Wireless	Job Number: J96091
Model: 1520 (4x4 5GHz 802.11 Client)	T-Log Number: T96173
	Project Manager: Irene Rademacher
Contact: Venkat Kalkunte	Project Coordinator: -
Standard: FCC 15.B / 15.407 (New Rules)	Class: N/A

Run #2: Bandwidth Measurements

Date of Test: 12/16/2014 0:00
 Test Engineer: Jack Liu
 Test Location: FT Lab #4A
 Config. Used: 1
 Config Change: None
 EUT Voltage: POE

Mode: HT40
 5725-5850MHz band (UNII3)
 Testing performed on port: 0

Power Setting	Frequency (MHz)	Bandwidth (MHz)		RBW Setting (MHz)	
		6dB	99%	6dB	99%
14	5775	75.69	75.61	0.1	1

Note 1: 6dB BW: RBW=100kHz, VBW ≥ 3*RBW, peak detector, max hold, auto sweep time.
 99% BW: RBW=1.5% of of 99%BW, VBW ≥ 3*RBW, peak detector, max hold, auto sweep time.

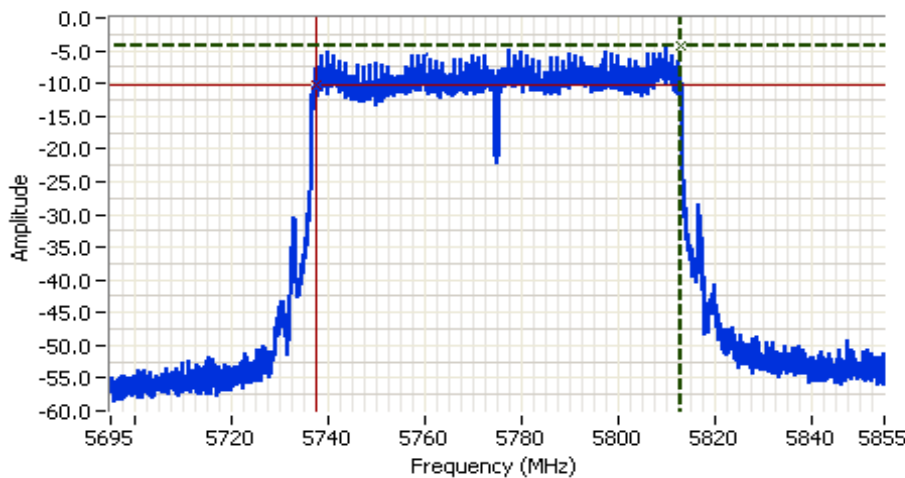

Analyzer Settings
 Agilent Technologies, E4446A
 CF: 5775.000 MHz
 SPAN: 160.000 MHz
 RB: 100 kHz
 VB: 300 kHz
 Detector: POS
 Attn: 20 DB
 RL Offset: 11.0 DB
 Sweep Time: 15.3ms
 Ref Lvl: 20.0 DBM

Comments
 6dB BW: 75.693 MHz
 802.11 ac80

Cursor 1	5813.1199	-4.18	
Cursor 2	5737.4271	-10.18	

Delta Freq. 75.693
 Delta Amplitude 6.00





EMC Test Data

Client: Vivint Wireless	Job Number: J96091
Model: 1520 (4x4 5GHz 802.11 Client)	T-Log Number: T96173
	Project Manager: Irene Rademacher
Contact: Venkat Kalkunte	Project Coordinator: -
Standard: FCC 15.B / 15.407 (New Rules)	Class: B

Conducted Emissions

(Elliott Laboratories Fremont Facility, Semi-Anechoic Chamber)

Test Specific Details

Objective: The objective of this test session is to perform final qualification testing of the EUT with respect to the specification listed above.

Date of Test: 9/3/2014	Config. Used: 1
Test Engineer: Jack Liu	Config Change: None
Test Location: FT Chamber#4	EUT Voltage: POE

General Test Configuration

For tabletop equipment, the EUT was located on a wooden table inside the semi-anechoic chamber, 40 cm from a vertical coupling plane and 80cm from the LISN. A second LISN was used for all local support equipment. Remote support equipment was located outside of the semi-anechoic chamber. Any cables running to remote support equipment were routed through metal conduit and when possible passed through a ferrite clamp upon exiting the chamber.

Ambient Conditions:	Temperature:	24 °C
	Rel. Humidity:	40 %

Summary of Results

Run #	Test Performed	Limit	Result	Margin
1	CE, AC Power, 120V/60Hz	Class B	Pass	46.7 dBµV @ 14.772 MHz (-3.3 dB)

Modifications Made During Testing

No modifications were made to the EUT during testing

Deviations From The Standard

No deviations were made from the requirements of the standard.

NOTE: EUT configured to transmit n40 MCS8 channel to 151 @ power 18.

Client: Vivint Wireless	Job Number: J96091
Model: 1520 (4x4 5GHz 802.11 Client)	T-Log Number: T96173
Contact: Venkat Kalkunte	Project Manager: Irene Rademacher
Standard: FCC 15.B / 15.407 (New Rules)	Project Coordinator: -
	Class: B

Run #1: AC Power Port Conducted Emissions, 0.15 - 30MHz, 120V/60Hz

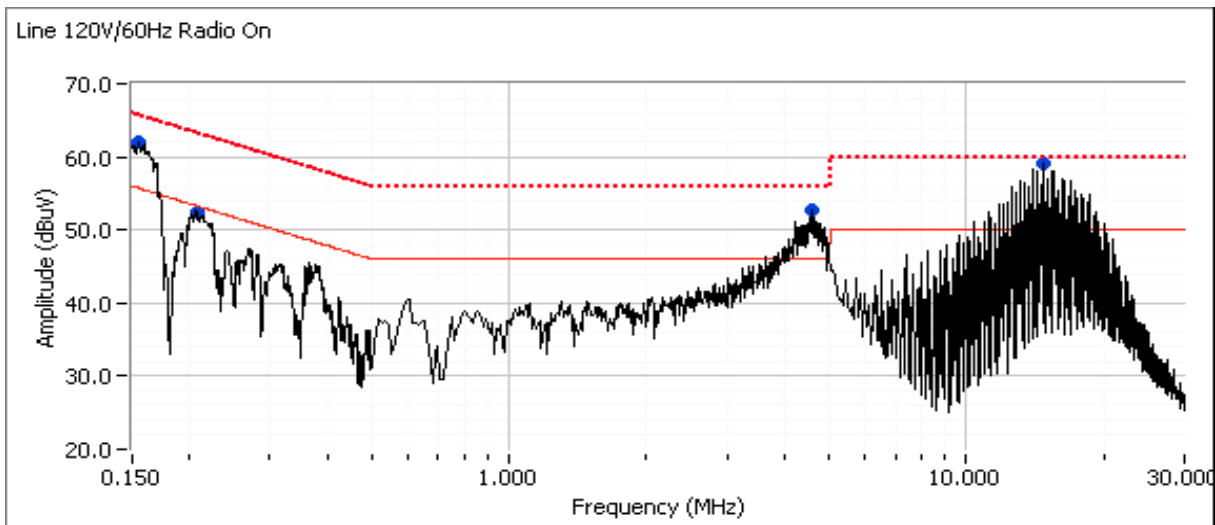
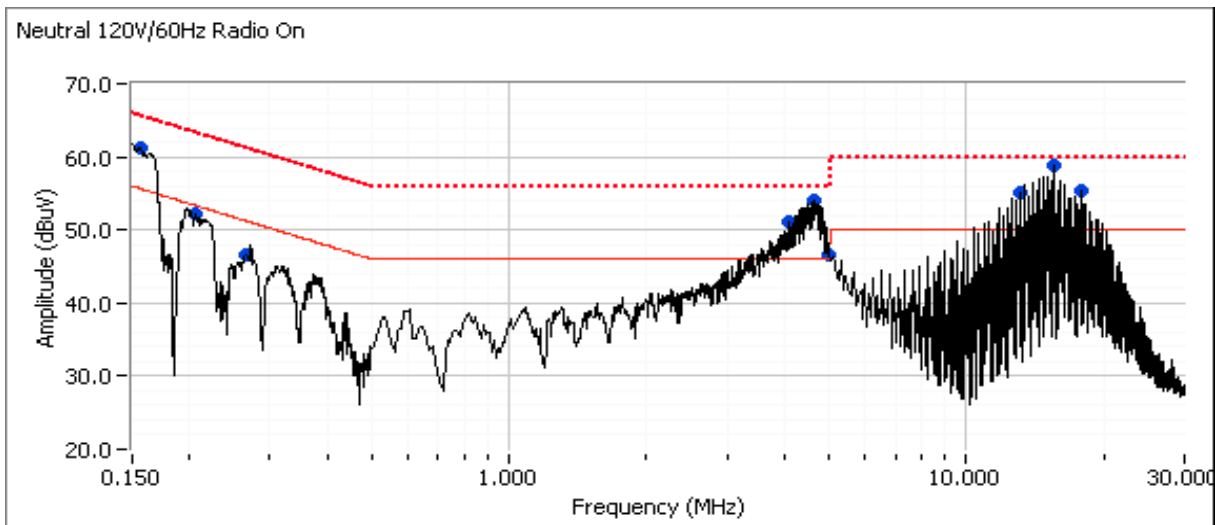



EMC Test Data

Client: Vivint Wireless	Job Number: J96091
Model: 1520 (4x4 5GHz 802.11 Client)	T-Log Number: T96173
	Project Manager: Irene Rademacher
Contact: Venkat Kalkunte	Project Coordinator: -
Standard: FCC 15.B / 15.407 (New Rules)	Class: B

Preliminary peak readings captured during pre-scan (peak readings vs. average limit)

Frequency MHz	Level dB μ V	AC Line	Class B		Detector QP/Ave	Comments
			Limit	Margin		
14.772	59.2	Line	50.0	9.2	Peak	
4.575	52.7	Line	46.0	6.7	Peak	
0.155	61.9	Line	55.7	6.2	Peak	
0.209	52.4	Line	53.3	-0.9	Peak	
0.205	52.2	Neutral	53.4	-1.2	Peak	
0.154	61.1	Neutral	55.7	5.4	Peak	
0.266	46.7	Neutral	51.3	-4.6	Peak	
4.638	54.0	Neutral	46.0	8.0	Peak	
4.106	51.2	Neutral	46.0	5.2	Peak	
15.558	58.8	Neutral	50.0	8.8	Peak	
13.101	55.2	Neutral	50.0	5.2	Peak	
17.740	55.4	Neutral	50.0	5.4	Peak	
4.988	46.6	Neutral	46.0	0.6	Peak	



EMC Test Data

Client: Vivint Wireless	Job Number: J96091
Model: 1520 (4x4 5GHz 802.11 Client)	T-Log Number: T96173
	Project Manager: Irene Rademacher
Contact: Venkat Kalkunte	Project Coordinator: -
Standard: FCC 15.B / 15.407 (New Rules)	Class: B

Final quasi-peak and average readings

Frequency MHz	Level dB μ V	AC Line	Class B		Detector QP/Ave	Comments
			Limit	Margin		
14.772	46.7	Line	50.0	-3.3	AVG	AVG (0.10s)
4.638	42.2	Neutral	46.0	-3.8	AVG	AVG (0.10s)
15.558	45.7	Neutral	50.0	-4.3	AVG	AVG (0.10s)
13.101	44.1	Neutral	50.0	-5.9	AVG	AVG (0.10s)
0.155	59.5	Line	65.7	-6.2	QP	QP (1.00s)
4.638	49.5	Neutral	56.0	-6.5	QP	QP (1.00s)
0.154	58.9	Neutral	65.8	-6.9	QP	QP (1.00s)
17.740	42.7	Neutral	50.0	-7.3	AVG	AVG (0.10s)
4.575	38.2	Line	46.0	-7.8	AVG	AVG (0.10s)
4.106	37.7	Neutral	46.0	-8.3	AVG	AVG (0.10s)
4.575	47.2	Line	56.0	-8.8	QP	QP (1.00s)
4.988	36.7	Neutral	46.0	-9.3	AVG	AVG (0.10s)
14.772	50.5	Line	60.0	-9.5	QP	QP (1.00s)
4.106	45.6	Neutral	56.0	-10.4	QP	QP (1.00s)
15.558	49.6	Neutral	60.0	-10.4	QP	QP (1.00s)
4.988	44.5	Neutral	56.0	-11.5	QP	QP (1.00s)
13.101	47.7	Neutral	60.0	-12.3	QP	QP (1.00s)
0.155	43.1	Line	55.7	-12.6	AVG	AVG (0.10s)
0.209	50.3	Line	63.2	-12.9	QP	QP (1.00s)
17.740	47.1	Neutral	60.0	-12.9	QP	QP (1.00s)
0.205	49.8	Neutral	63.4	-13.6	QP	QP (1.00s)
0.154	41.2	Neutral	55.8	-14.6	AVG	AVG (0.10s)
0.266	43.5	Neutral	61.2	-17.7	QP	QP (1.00s)
0.209	35.0	Line	53.2	-18.2	AVG	AVG (0.10s)
0.205	32.3	Neutral	53.4	-21.1	AVG	AVG (0.10s)
0.266	29.4	Neutral	51.2	-21.8	AVG	AVG (0.10s)

End of Report

This page is intentionally blank and marks the last page of this test report.