

EMC Test Report

Application for Grant of Equipment Authorization

FCC Part 15, Subpart E

Model: SR1530

FCC ID: 2AAAS-AP03

APPLICANT: Vivint Wireless
3945 Freedom Circle, Suite 150
Santa Clara, CA 95054

TEST SITE(S): National Technical Systems - Silicon Valley
41039 Boyce Road.
Fremont, CA. 94538-2435

IC SITE REGISTRATION #: 2845B-3; 2845B-4, 2845B-5, 2845B-7

REPORT DATE: June 8, 2015

REISSUE DATE: June 8, 2015

FINAL TEST DATES: September 3, 2014 and February 23, 24, 25,
March 2, 10, 11 and 12, 2015

TOTAL NUMBER OF PAGES: 146

PROGRAM MGR /
TECHNICAL REVIEWER:

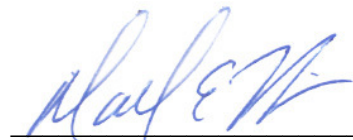

Mark E Hill
Staff Engineer

QUALITY ASSURANCE DELEGATE /
FINAL REPORT PREPARER:

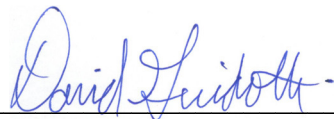

David Guidotti
Senior Technical Writer



National Technical Systems - Silicon Valley is accredited by the A2LA, certificate number 0214.26, to perform the test(s) listed in this report, except where noted otherwise. This report and the information contained herein represent the results of testing test articles identified and selected by the client performed to specifications and/or procedures selected by the client. National Technical Systems (NTS) makes no representations, expressed or implied, that such testing is adequate (or inadequate) to demonstrate efficiency, performance, reliability, or any other characteristic of the articles being tested, or similar products. This report should not be relied upon as an endorsement or certification by NTS of the equipment tested, nor does it represent any statement whatsoever as to its merchantability or fitness of the test article, or similar products, for a particular purpose. This report shall not be reproduced except in full

REVISION HISTORY

Rev#	Date	Comments	Modified By
-	June 8, 2015	First release	
1.0	July 10, 2015	Fixed 15.407(e) limit reference. Clarified C63.10 product placement during radiated measurements. Clarified AC conducted emissions setup.	MEH

TABLE OF CONTENTS

REVISION HISTORY	2
TABLE OF CONTENTS	3
SCOPE	4
OBJECTIVE	4
STATEMENT OF COMPLIANCE	5
DEVIATIONS FROM THE STANDARDS	5
TEST RESULTS SUMMARY	6
UNII / LELAN DEVICES	6
GENERAL REQUIREMENTS APPLICABLE TO ALL BANDS	8
MEASUREMENT UNCERTAINTIES	8
EQUIPMENT UNDER TEST (EUT) DETAILS	9
GENERAL.....	9
OTHER EUT DETAILS.....	9
ANTENNA SYSTEM	9
ENCLOSURE.....	10
MODIFICATIONS.....	10
SUPPORT EQUIPMENT.....	10
EUT INTERFACE PORTS	10
EUT OPERATION	11
TEST SITE	12
GENERAL INFORMATION	12
CONDUCTED EMISSIONS CONSIDERATIONS	12
RADIATED EMISSIONS CONSIDERATIONS	12
MEASUREMENT INSTRUMENTATION	13
RECEIVER SYSTEM	13
INSTRUMENT CONTROL COMPUTER	13
LINE IMPEDANCE STABILIZATION NETWORK (LISN).....	13
FILTERS/ATTENUATORS	14
ANTENNAS.....	14
ANTENNA MAST AND EQUIPMENT TURNTABLE.....	14
INSTRUMENT CALIBRATION.....	14
TEST PROCEDURES	15
EUT AND CABLE PLACEMENT	15
CONDUCTED EMISSIONS.....	15
RADIATED EMISSIONS	15
CONDUCTED EMISSIONS FROM ANTENNA PORT	19
BANDWIDTH MEASUREMENTS	19
SPECIFICATION LIMITS AND SAMPLE CALCULATIONS	20
CONDUCTED EMISSIONS SPECIFICATION LIMITS: FCC 15.207; FCC 15.107(A), RSS GEN	20
GENERAL TRANSMITTER RADIATED EMISSIONS SPECIFICATION LIMITS	21
RECEIVER RADIATED SPURIOUS EMISSIONS SPECIFICATION LIMITS	21
FCC 15.407 (A) OUTPUT POWER LIMITS	21
SPURIOUS EMISSIONS LIMITS –UNII AND LELAN DEVICES	22
SAMPLE CALCULATIONS - CONDUCTED EMISSIONS	22
SAMPLE CALCULATIONS - RADIATED EMISSIONS.....	22
SAMPLE CALCULATIONS - FIELD STRENGTH TO EIRP CONVERSION.....	23
APPENDIX A TEST EQUIPMENT CALIBRATION DATA	24
APPENDIX B TEST DATA	26
END OF REPORT	146

SCOPE

An electromagnetic emissions test has been performed on the Vivint Wireless model SR1530, pursuant to the following rules:

FCC Part 15, Subpart E requirements for UNII Devices

Conducted and radiated emissions data has been collected, reduced, and analyzed within this report in accordance with measurement guidelines set forth in the following reference standards and as outlined in National Technical Systems - Silicon Valley test procedures:

ANSI C63.10-2009

FCC General UNII Test Procedures KDB789033

The intentional radiator above has been tested in a simulated typical installation to demonstrate compliance with the relevant Industry Canada performance and procedural standards.

Final system data was gathered in a mode that tended to maximize emissions by varying orientation of EUT, orientation of power and I/O cabling, antenna search height, and antenna polarization.

Every practical effort was made to perform an impartial test using appropriate test equipment of known calibration. All pertinent factors have been applied to reach the determination of compliance.

OBJECTIVE

The primary objective of the manufacturer is compliance with the regulations outlined in the previous section.

Prior to marketing in the USA, all unlicensed transmitters and transceivers require certification. Receive-only devices operating between 30 MHz and 960 MHz are subject to either certification or a manufacturer's declaration of conformity, with all other receive-only devices exempt from the technical requirements.

Certification is a procedure where the manufacturer submits test data and technical information to a certification body and receives a certificate or grant of equipment authorization upon successful completion of the certification body's review of the submitted documents. Once the equipment authorization has been obtained, the label indicating compliance must be attached to all identical units, which are subsequently manufactured.

Maintenance of compliance is the responsibility of the manufacturer. Any modification of the product which may result in increased emissions should be checked to ensure compliance has been maintained (i.e., printed circuit board layout changes, different line filter, different power supply, harnessing or I/O cable changes, etc.).

STATEMENT OF COMPLIANCE

The tested sample of Vivint Wireless model SR1530 complied with the requirements of the following regulations:

FCC Part 15, Subpart E requirements for UNII Devices

Maintenance of compliance is the responsibility of the manufacturer. Any modifications to the product should be assessed to determine their potential impact on the compliance status of the device with respect to the standards detailed in this test report.

The test results recorded herein are based on a single type test of Vivint Wireless model SR1530 and therefore apply only to the tested sample. The sample was selected and prepared by Venkat Kalkunte of Vivint Wireless.

DEVIATIONS FROM THE STANDARDS

No deviations were made from the published requirements listed in the scope of this report.

TEST RESULTS SUMMARY

UNII / LELAN DEVICES

Operation in the 5.15 – 5.25 GHz Band

FCC Rule Part	RSS Rule Part	Description	Measured Value / Comments	Limit / Requirement	Result
15.407 (a) (1) (i)	-	Output Power	n20: 26.8 dBm (0.477W) n40: 26.8 dBm (0.483W) ac80: 18.5 dBm (0.070W) (Max eirp: 2.42W)	30dBm	Complies
15.407 (a) (1) (i)	-	EIRP 30deg above horizon	83.4mW	125mW (21dBm)	Complies
15.407 (a) (1)	-	Power Spectral Density	n20: 13.6dBm/MHz n40: 10.7dBm/MHz ac80: 0.8dBm/MHz	17 dBm/MHz	Complies

Operation in the 5.25 – 5.35 GHz Band

FCC Rule Part	RSS Rule Part	Description	Measured Value / Comments	Limit / Requirement	Result (margin)
15.407(a) (2)	-	26dB Bandwidth	n20: 23.3MHz	N/A – limits output power if < 20MHz	N/A
15.407(a) (2)	RSS-210 A9.2(2)	Output Power	n20: 22.4 dBm (0.175W) n40: 22.4 dBm (0.174W) ac80: 21.4 dBm (0.138W) (Max eirp: 0.984W (29.9 dBm))	24 dBm / 250mW (eirp < 30dBm)	Complies
15.407(a) (2)	-	Power Spectral Density	n20: 9.4dBm/MHz n40: 6.2dBm/MHz ac80: 4.0dBm/MHz	11 dBm/MHz	Complies

Operation in the 5.47 – 5.725 GHz Band

FCC Rule Part	RSS Rule Part	Description	Measured Value / Comments	Limit / Requirement	Result (margin)
15.407(a) (2)	-	26dB Bandwidth	n20: 23.3MHz	N/A – limits output power if < 20MHz	N/A
15.407(a) (2)	-	Output Power	n20: 21.9dBm (0.156W) n40: 21.5dBm (0.141W) ac80: 21.8dBm (0.152W) (Max eirp: 0.988W (29.9dBm))	24 dBm / 250mW (eirp < 30dBm)	Complies
15.407(a) (2)		Power Spectral Density	n20: 8.6dBm/MHz n40: 5.8dBm/MHz ac80: 4.6dBm/MHz	11 dBm/MHz	Complies

Operation in the 5.725 – 5.850 GHz Band

FCC Rule Part	RSS Rule Part	Description	Measured Value / Comments	Limit / Requirement	Result (margin)
15.407(e)	-	6dB Bandwidth	n20: 17.6MHz n40: 36.27MHz ac80: 75.0MHz	>500kHz	N/A
15.407(a) (3)	-	Output Power	n20: 26.9dBm (0.494W) n40: 25.8dBm (0.385W) ac80: 18.8dBm (0.085W) (Max eirp: 3.5W)	30 dBm (eirp < 36dBm)	Complies
15.407(a) (3)	-	Power Spectral Density	n20: 13.7dBm/MHz n40: 9.7dBm/MHz ac80: 1.1dBm/MHz	30 dBm/500kHz	Complies

Requirements for all U-NII/LELAN bands

FCC Rule Part	RSS Rule Part	Description	Measured Value / Comments	Limit / Requirement	Result
15.407	-	Modulation	Digital Modulation is used	Digital modulation is required	Complies
15.407(b) / 15.209	-	Spurious Emissions	53.7 dBμV/m @ 5150.0 MHz (-0.3 dB)	Refer to page 22	Complies
15.407 (c)	-	Operation in the absence of information to transmit	Operation is discontinued in the absence of information	Device shall automatically discontinue operation in the absence of information to transmit	Complies
15.407 (g)	-	Frequency Stability	Frequency stability is +/- 10ppm	Signal shall remain within the allocated band	Complies
15.407 (h1)	-	Transmit Power Control	TCP mechanism is discussed in the Operational Description	The U-NII device shall have the capability to operate with a mean EIRP value lower than 24dBm (250mW)	Complies
15.407 (h2)	-	Dynamic frequency Selection (device with radar detection)	Refer to separate test report, reference R98544	Threshold -62dBm (-64dBm if eirp > 200mW) Channel Availability Check > 60s Channel closing transmission time < 260ms Channel move time < 10s Non occupancy period > 30minutes	Complies

GENERAL REQUIREMENTS APPLICABLE TO ALL BANDS

FCC Rule Part	RSS Rule part	Description	Measured Value / Comments	Limit / Requirement	Result (margin)
15.203	-	RF Connector	Antenna is integral	Unique or integral antenna required	Complies
15.207	-	AC Conducted Emissions	46.7 dB μ V @ 14.772 MHz (-3.3 dB)	Refer to page 20	Complies
15.247 (b) (5) 15.407 (f)	-	RF Exposure Requirements	Refer to MPE calculations in separate exhibit	Refer to OET 65, FCC Part 1 and RSS 102	Complies

MEASUREMENT UNCERTAINTIES

ISO/IEC 17025 requires that an estimate of the measurement uncertainties associated with the emissions test results be included in the report. The measurement uncertainties given below are based on a 95% confidence level and were calculated in accordance with UKAS document LAB 34.

Measurement Type	Measurement Unit	Frequency Range	Expanded Uncertainty
RF power, conducted (power meter)	dBm	25 to 7000 MHz	± 0.52 dB
RF power, conducted (Spectrum analyzer)	dBm	25 to 7000 MHz	± 0.7 dB
Conducted emission of transmitter	dBm	25 to 26500 MHz	± 0.7 dB
Conducted emission of receiver	dBm	25 to 26500 MHz	± 0.7 dB
Radiated emission (substitution method)	dBm	25 to 26500 MHz	± 2.5 dB
Radiated emission (field strength)	dB μ V/m	25 to 1000 MHz	± 3.6 dB
		1000 to 40000 MHz	± 6.0 dB
Conducted Emissions (AC Power)	dB μ V	0.15 to 30 MHz	± 2.4 dB

EQUIPMENT UNDER TEST (EUT) DETAILS

GENERAL

The Vivint Wireless model SR1530 is a 5GHz 802.11 4x4 access point device. The EUT would normally be pole or wall mounted. For testing, it was placed on a tabletop. The EUT is powered via POE connection.

The sample was received on September 3, 2014 and February 23, 2015 and tested on September 3, 2014 and February 23, 24, 25, March 2, 10, 11 and 12, 2015. The EUT consisted of the following component(s):

Company	Model	Description	Serial Number	FCC ID
Vivint Wireless	SR1530	5GHz 802.11 4x4 radio	-	2AAAS-AP02

The following sample was used for AC conducted emissions

Company	Model	Description	Serial Number	FCC ID
Vivint Wireless	1520	5GHz 802.11 4x4 radio	-	2AAAS-CE02

Note – the SR1520 is electrically identical to the SR5130. The only differences include a different antenna type and the DFS function. The SR1530 is a DFS master, while the SR5120 is a DFS client device.

OTHER EUT DETAILS

The following EUT details should be noted:

20/40MHz/80MHz

11a legacy data rates not supported

HT20 – MCS0 thru MCS7 (min of 2 spatial stream, max of 4)

HT40 – MCS0 thru MCS7 (min of 2 spatial stream, max of 4)

DFS Master device

Outdoor installation

4x4 only operation (does not support 3Tx, 2Tx or 1Tx operational modes)

Antenna: ~4-5.5dBi (refer to test data for specifics)

Non-point-to-point system

Beamforming supported

FCC approval only

Supports 256-QAM for 20 and 40MHz bandwidths

Channel 144 (20MHz) and 142 (40MHz) to be included

Channels within the 5600-5650MHz band supported

ANTENNA SYSTEM

The antenna system consists of 4 element panel antenna integral to the device.

Antenna port measurements were performed at the end of the internal RF cables that connect the radio circuitry.

ENCLOSURE

The EUT enclosure is primarily constructed of plastic. It measures approximately 26 cm wide by 10 cm deep by 26 cm high.

MODIFICATIONS

No modifications were made to the EUT during the time the product was at NTS Silicon Valley.

SUPPORT EQUIPMENT (Radiated and Antenna Port)

No local support equipment was used during testing.

The following equipment was used as remote support equipment for emissions testing:

Company	Model	Description	Serial Number	FCC ID
-	PSE802G	POE Injector	-	-
Acer	Aspire 5735	Laptop Computer	LXAU59X265903089 BE2000	-

SUPPORT EQUIPMENT (AC Conducted)

The following equipment was used as local support equipment during testing.

Company	Model	Description	Serial Number	FCC ID
-	PSE802G	POE Injector	-	-

The following equipment was used as remote support equipment for emissions testing:

Company	Model	Description	Serial Number	FCC ID
Acer	Aspire 5735	Laptop Computer	LXAU59X265903089 BE2000	-

EUT INTERFACE PORTS (Radiated and Antenna Port)

The I/O cabling configuration during testing was as follows:

Port	Connected To	Description	Cable(s)	
			Shielded or Unshielded	Length(m)
POE	POE Injector	CAT5	Unshielded	7.0
USB	Not Connected	-	-	-

Additional on Support Equipment

Port	Connected To	Description	Cable(s)	
			Shielded or Unshielded	Length(m)
POE Injector	Laptop	CAT5	Unshielded	2.0

EUT INTERFACE PORTS (AC Conducted Emissions)

The I/O cabling configuration during testing was as follows:

Port	Connected To	Description	Cable(s)	
			Shielded or Unshielded	Length(m)
POE	POE Injector	CAT5	Unshielded	2.0
USB	Not Connected	-	-	-

Additional on Support Equipment

Port	Connected To	Description	Cable(s)	
			Shielded or Unshielded	Length(m)
POE Injector	Laptop	CAT5	Unshielded	7.0

EUT OPERATION

During emissions testing the EUT was configured to continuously transmit at the noted channel and power level. All transmissions were 4Tx with beamforming active.

During AC conducted emissions, the EUT was configured to continuously transmit on channel 151, n40 MCS8, at power 18dBm.

TEST SITE**GENERAL INFORMATION**

Final test measurements were taken at the test sites listed below. Pursuant to section 2.948 of the FCC's Rules and section 3.3 of RSP-100, construction, calibration, and equipment data has been filed with the Commission and with industry Canada.

Site	Designation / Registration Numbers		Location
	FCC	Canada	
Chamber 4	US0027	2845B-4	41039 Boyce Road Fremont, CA 94538-2435
Chamber 7	US0027	2845B-7	

ANSI C63.4 recommends that ambient noise at the test site be at least 6 dB below the allowable limits. Ambient levels are below this requirement. The test site(s) contain separate areas for radiated and conducted emissions testing. Considerable engineering effort has been expended to ensure that the facilities conform to all pertinent requirements of ANSI C63.4.

CONDUCTED EMISSIONS CONSIDERATIONS

Conducted emissions testing is performed in conformance with ANSI C63.10. Measurements are made with the EUT connected to the public power network through a nominal, standardized RF impedance, which is provided by a line impedance stabilization network, known as a LISN. A LISN is inserted in series with each current-carrying conductor in the EUT power cord.

RADIATED EMISSIONS CONSIDERATIONS

The FCC has determined that radiation measurements made in a shielded enclosure are not suitable for determining levels of radiated emissions. Radiated measurements are performed in an open field environment or in a semi-anechoic chamber. The test sites are maintained free of conductive objects within the CISPR defined elliptical area incorporated in ANSI C63.4 guidelines and meet the Normalized Site Attenuation (NSA) requirements of ANSI C63.4.

MEASUREMENT INSTRUMENTATION

RECEIVER SYSTEM

An EMI receiver as specified in CISPR 16-1-1 is used for emissions measurements. The receivers used can measure over the frequency range of 9 kHz up to 2000 MHz. These receivers allow both ease of measurement and high accuracy to be achieved. The receivers have Peak, Average, and CISPR (Quasi-peak) detectors built into their design so no external adapters are necessary. The receiver automatically sets the required bandwidth for the CISPR detector used during measurements. If the repetition frequency of the signal being measured is below 20Hz, peak measurements are made in lieu of Quasi-Peak measurements.

For measurements above the frequency range of the receivers, a spectrum analyzer is utilized because it provides visibility of the entire spectrum along with the precision and versatility required to support engineering analysis. Average measurements above 1000MHz are performed on the spectrum analyzer using the linear-average method with a resolution bandwidth of 1 MHz and a video bandwidth of 10 Hz, unless the signal is pulsed in which case the average (or video) bandwidth of the measuring instrument is reduced to onset of pulse desensitization and then increased.

INSTRUMENT CONTROL COMPUTER

The receivers utilize either a Rohde & Schwarz EZM Spectrum Monitor/Controller or contain an internal Spectrum Monitor/Controller to view and convert the receiver measurements to the field strength at an antenna or voltage developed at the LISN measurement port, which is then compared directly with the appropriate specification limit. This provides faster, more accurate readings by performing the conversions described under Sample Calculations within the Test Procedures section of this report. Results are printed in a graphic and/or tabular format, as appropriate. A personal computer is used to record all measurements made with the receivers.

The Spectrum Monitor provides a visual display of the signal being measured. In addition, the controller or a personal computer run automated data collection programs which control the receivers. This provides added accuracy since all site correction factors, such as cable loss and antenna factors are added automatically.

LINE IMPEDANCE STABILIZATION NETWORK (LISN)

Line conducted measurements utilize a fifty microhenry Line Impedance Stabilization Network as the monitoring point. The LISN used also contains a 250 uH CISPR adapter. This network provides for calibrated radio frequency noise measurements by the design of the internal low pass and high pass filters on the EUT and measurement ports, respectively.

FILTERS/ATTENUATORS

External filters and precision attenuators are often connected between the receiving antenna or LISN and the receiver. This eliminates saturation effects and non-linear operation due to high amplitude transient events.

ANTENNAS

A loop antenna is used below 30 MHz. For the measurement range 30 MHz to 1000 MHz either a combination of a biconical antenna and a log periodic or a bi-log antenna is used. Above 1000 MHz, horn antennas are used. The antenna calibration factors to convert the received voltage to an electric field strength are included with appropriate cable loss and amplifier gain factors to determine an overall site factor, which is then programmed into the test receivers or incorporated into the test software.

ANTENNA MAST AND EQUIPMENT TURNTABLE

The antennas used to measure the radiated electric field strength are mounted on a non-conductive antenna mast equipped with a motor-drive to vary the antenna height. Measurements below 30 MHz are made with the loop antenna at a fixed height of 1m above the ground plane.

ANSI C63.10 specifies that the test height above ground for table mounted devices shall be 80 centimeters for measurements below 1GHz and 1.5m for measurements above 1GHz. Floor mounted equipment shall be placed on the ground plane if the device is normally used on a conductive floor or separated from the ground plane by insulating material from 3 to 12 mm if the device is normally used on a non-conductive floor as specified in ANSI C63.4. During radiated measurements, the EUT is positioned on a motorized turntable in conformance with this requirement.

INSTRUMENT CALIBRATION

All test equipment is regularly checked to ensure that performance is maintained in accordance with the manufacturer's specifications. All antennas are calibrated at regular intervals with respect to tuned half-wave dipoles. An exhibit of this report contains the list of test equipment used and calibration information.

TEST PROCEDURES

EUT AND CABLE PLACEMENT

The regulations require that interconnecting cables be connected to the available ports of the unit and that the placement of the unit and the attached cables simulate the worst case orientation that can be expected from a typical installation, so far as practicable. To this end, the position of the unit and associated cabling is varied within the guidelines of ANSI C63.10, and the worst-case orientation is used for final measurements.

CONDUCTED EMISSIONS

Conducted emissions are measured at the plug end of the power cord supplied with the EUT. Excess power cord length is wrapped in a bundle between 30 and 40 centimeters in length near the center of the cord. Preliminary measurements are made to determine the highest amplitude emission relative to the specification limit for all the modes of operation. Placement of system components and varying of cable positions are performed in each mode. A final peak mode scan is then performed in the position and mode for which the highest emission was noted on all current carrying conductors of the power cord.

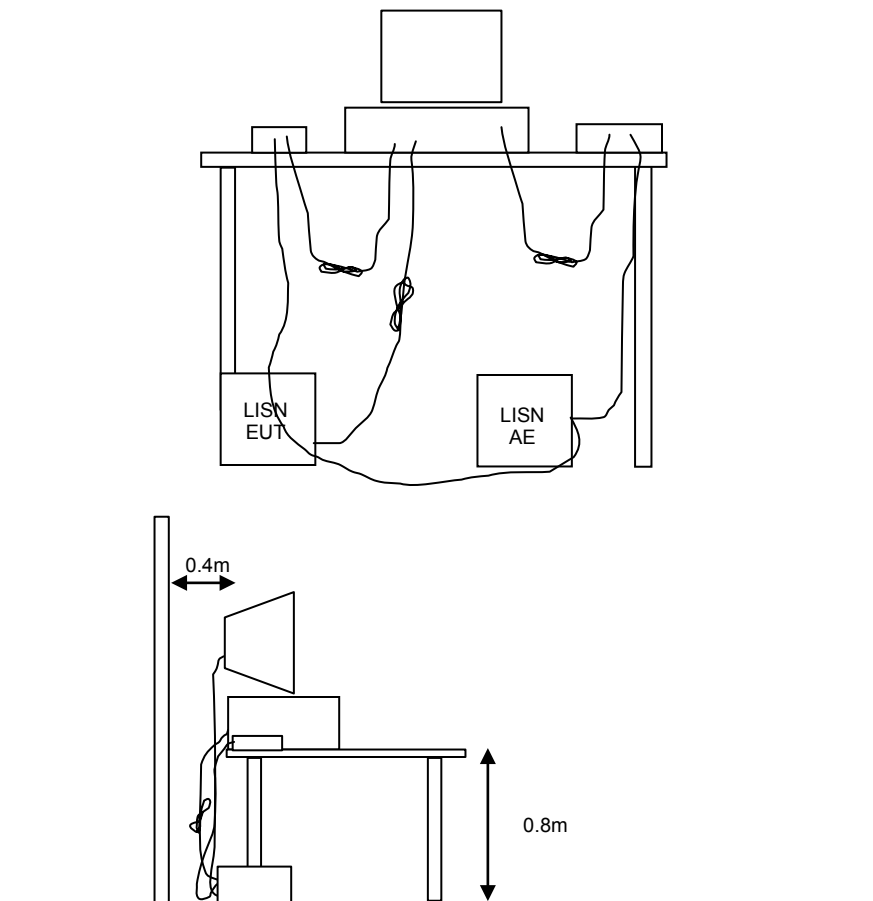

Figure 1 Typical Conducted Emissions Test Configuration

RADIATED EMISSIONS

A preliminary scan of the radiated emissions is performed in which all significant EUT frequencies are identified with the system in a nominal configuration. At least two scans are performed, one scan for each antenna polarization (horizontal and vertical; loop parallel and perpendicular to the EUT). During the preliminary scans, the EUT is rotated through 360°, the antenna height is varied (for measurements above 30 MHz) and cable positions are varied to determine the highest emission relative to the limit. Preliminary scans may be performed in a fully anechoic chamber for the purposes of identifying the frequencies of the highest emissions from the EUT.

A speaker is provided in the receiver to aid in discriminating between EUT and ambient emissions. Other methods used during the preliminary scan for EUT emissions involve scanning with near field magnetic loops, monitoring I/O cables with RF current clamps, and cycling power to the EUT.

Final maximization is a phase in which the highest amplitude emissions identified in the spectral search are viewed while the EUT azimuth angle is varied from 0 to 360 degrees relative to the receiving antenna. The azimuth, which results in the highest emission is then maintained while varying the antenna height from one to four meters (for measurements above 30 MHz, measurements below 30 MHz are made with the loop antenna at a fixed height of 1m). The result is the identification of the highest amplitude for each of the highest peaks. Each recorded level is corrected in the receiver using appropriate factors for cables, connectors, antennas, and preamplifier gain.

When testing above 18 GHz, the receive antenna is located at 1meter from the EUT and the antenna height is restricted to a maximum of 2.5 meters.

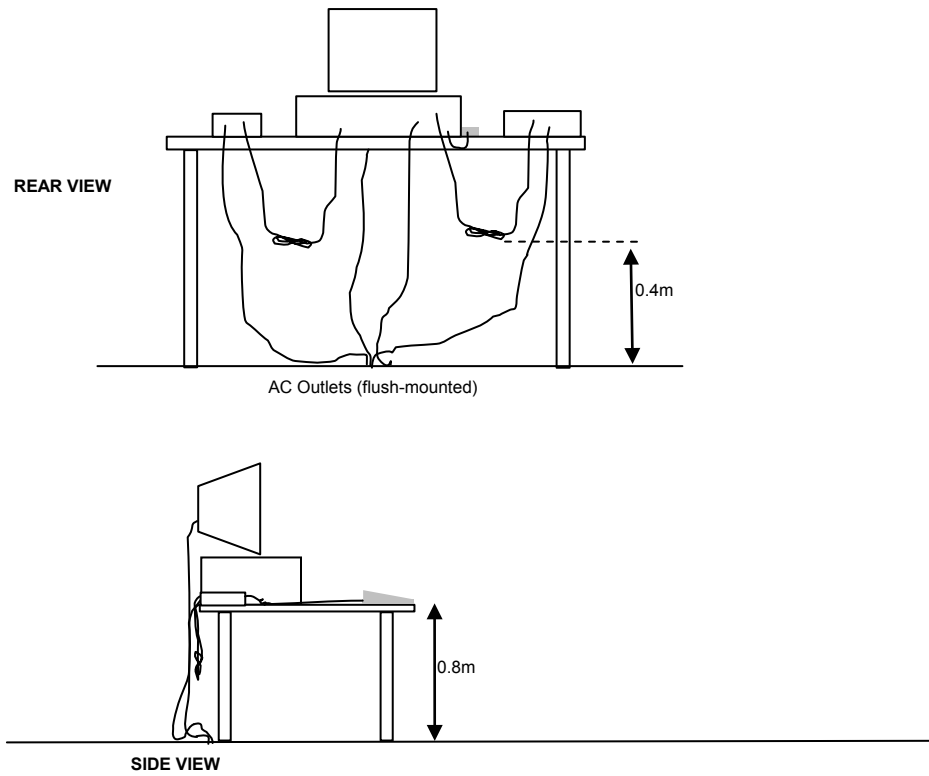

Typical Test Configuration for Radiated Field Strength Measurements

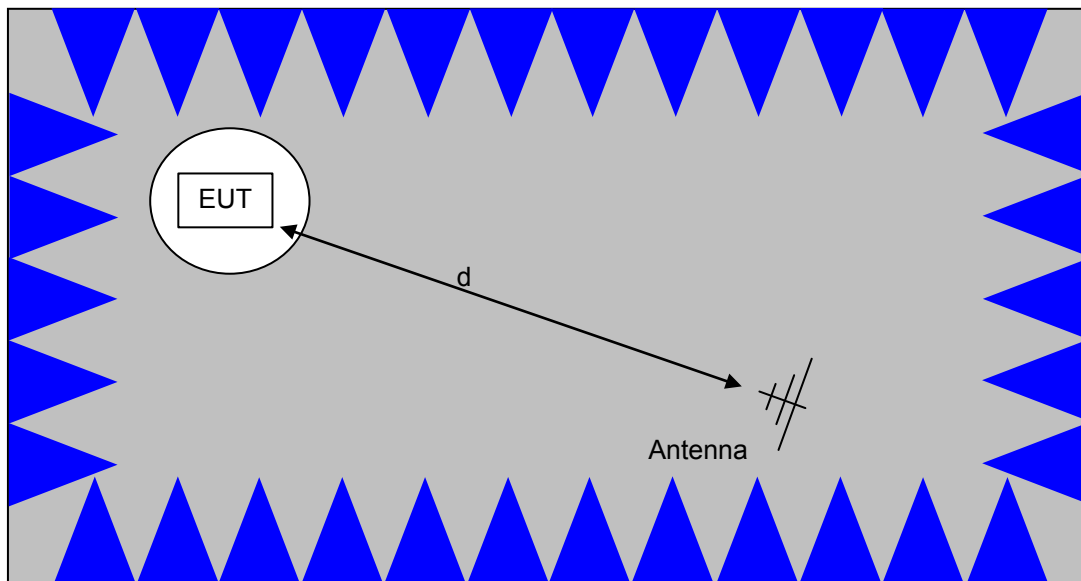

The anechoic materials on the walls and ceiling ensure compliance with the normalized site attenuation requirements of CISPR 16 / CISPR 22 / ANSI C63.4 for an alternate test site at the measurement distances used.

Floor-standing equipment is placed on the floor with insulating supports between the unit and the ground plane.

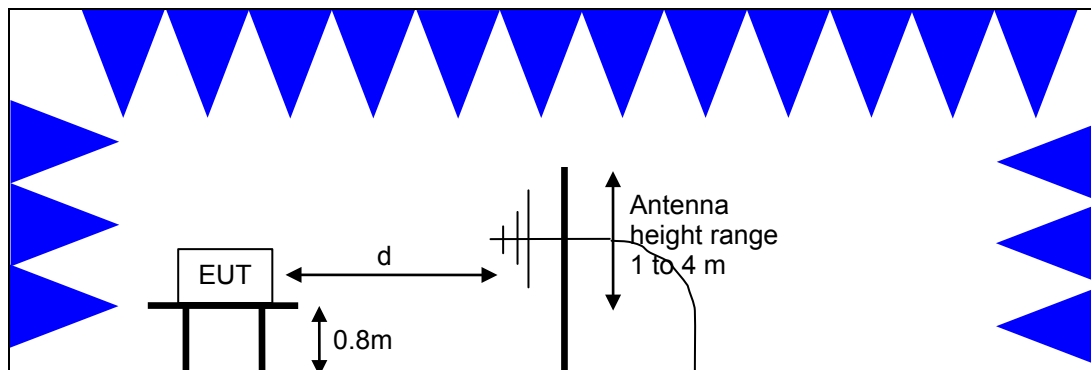

Test Configuration for Radiated Field Strength Measurements
Semi-Anechoic Chamber, Plan and Side Views

CONDUCTED EMISSIONS FROM ANTENNA PORT

Direct measurements of power, bandwidth and power spectral density are performed, where possible, with the antenna port of the EUT connected to either the power meter or spectrum analyzer via a suitable attenuator and/or filter. These are used to ensure that the front end of the measurement instrument is not overloaded by the fundamental transmission.

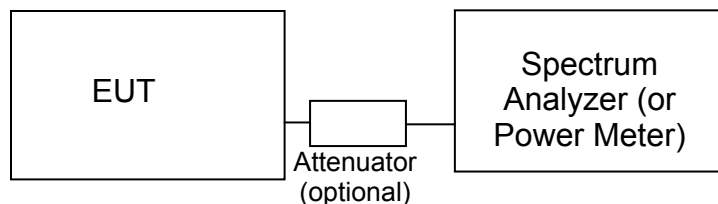
Test Configuration for Antenna Port Measurements

Measurement bandwidths (video and resolution) are set in accordance with the relevant standards and NTS Silicon Valley's test procedures for the type of radio being tested. When power measurements are made using a resolution bandwidth less than the signal bandwidth the power is calculated by summing the power across the signal bandwidth using either the analyzer channel power function or by capturing the trace data and calculating the power using software. In both cases the summed power is corrected to account for the equivalent noise bandwidth (ENBW) of the resolution bandwidth used.

If power averaging is used (typically for certain digital modulation techniques), the EUT is configured to transmit continuously. Power averaging is performed using either the built-in function of the analyzer or, if the analyzer does not feature power averaging, using external software. In both cases the average power is calculated over a number of sweeps (typically 100). When the EUT cannot be configured to continuously transmit then either the analyzer is configured to perform a gated sweep to ensure that the power is averaged over periods that the device is transmitting or power averaging is disabled and a max-hold feature is used.

If a power meter is used to make output power measurements the sensor head type (peak or average) is stated in the test data table.

BANDWIDTH MEASUREMENTS

The 6dB, 20dB, 26dB and/or 99% signal bandwidth are measured using the bandwidths recommended by ANSI C63.10 and RSS GEN.

SPECIFICATION LIMITS AND SAMPLE CALCULATIONS

The limits for conducted emissions are given in units of microvolts, and the limits for radiated emissions are given in units of microvolts per meter at a specified test distance. Data is measured in the logarithmic form of decibels relative to one microvolt, or dB microvolts (dBuV). For radiated emissions, the measured data is converted to the field strength at the antenna in dB microvolts per meter (dBuV/m). The results are then converted to the linear forms of uV and uV/m for comparison to published specifications.

For reference, converting the specification limits from linear to decibel form is accomplished by taking the base ten logarithm, then multiplying by 20. These limits in both linear and logarithmic form are as follows:

CONDUCTED EMISSIONS SPECIFICATION LIMITS: FCC 15.207; FCC 15.107(a), RSS GEN

The table below shows the limits for the emissions on the AC power line from an intentional radiator and a receiver.

Frequency (MHz)	Average Limit (dBuV)	Quasi Peak Limit (dBuV)
0.150 to 0.500	Linear decrease on logarithmic frequency axis between 56.0 and 46.0	Linear decrease on logarithmic frequency axis between 66.0 and 56.0
0.500 to 5.000	46.0	56.0
5.000 to 30.000	50.0	60.0

GENERAL TRANSMITTER RADIATED EMISSIONS SPECIFICATION LIMITS

The table below shows the limits for the spurious emissions from transmitters that fall in restricted bands¹ (with the exception of transmitters operating under FCC Part 15 Subpart D and RSS 210 Annex 9), the limits for all emissions from a low power device operating under the general rules of RSS 310 (tables 3 and 4), RSS 210 (table 2) and FCC Part 15 Subpart C section 15.209.

Frequency Range (MHz)	Limit (uV/m)	Limit (dBuV/m @ 3m)
0.009-0.490	2400/F _{KHz} @ 300m	67.6-20*log ₁₀ (F _{KHz}) @ 300m
0.490-1.705	24000/F _{KHz} @ 30m	87.6-20*log ₁₀ (F _{KHz}) @ 30m
1.705 to 30	30 @ 30m	29.5 @ 30m
30 to 88	100 @ 3m	40 @ 3m
88 to 216	150 @ 3m	43.5 @ 3m
216 to 960	200 @ 3m	46.0 @ 3m
Above 960	500 @ 3m	54.0 @ 3m

RECEIVER RADIATED SPURIOUS EMISSIONS SPECIFICATION LIMITS

The table below shows the limits for the spurious emissions from receivers as detailed in FCC Part 15.109, RSS 210 Table 2, RSS GEN Table 1 and RSS 310 Table 3. Note that receivers operating outside of the frequency range 30 MHz – 960 MHz are exempt from the requirements of 15.109.

Frequency Range (MHz)	Limit (uV/m @ 3m)	Limit (dBuV/m @ 3m)
30 to 88	100	40
88 to 216	150	43.5
216 to 960	200	46.0
Above 960	500	54.0

FCC 15.407 (a) OUTPUT POWER LIMITS

The table below shows the limits for output power and output power density. Where the signal bandwidth is less than 20 MHz the maximum output power is reduced to the power spectral density limit plus 10 times the log of the bandwidth (in MHz).

Operating Frequency (MHz)	Output Power	Power Spectral Density
5150 – 5250	1000 mW (30 dBm)	17dBm/MHz
5250 – 5350 and 5470-5725	250 mW (24 dBm)	11 dBm/MHz
5725 – 5850	1 Watts (30 dBm)	30 dBm/500kHz

¹ The restricted bands are detailed in FCC 15.203, RSS 210 Table 1 and RSS 310 Table 2

For system using antennas with gains exceeding 6dBi, the output power and power spectral density limits are reduced by 1dB for every dB the antenna gain exceeds 6dBi.

SPURIOUS EMISSIONS LIMITS –UNII and LELAN DEVICES

The spurious emissions limits for signals below 1GHz are the FCC/RSS-GEN general limits. For emissions above 1GHz, signals in restricted bands are subject to the FCC/RSS GEN general limits. All other signals have a limit of -27dBm/MHz , which is a field strength of 68.3dBuV/m/MHz at a distance of 3m. For devices operating in the 5725-5850Mhz bands under the LELAN/UNII rules, the limit within 10MHz of the allocated band is increased to -17dBm/MHz .

SAMPLE CALCULATIONS - CONDUCTED EMISSIONS

Receiver readings are compared directly to the conducted emissions specification limit (decibel form) as follows:

$$R_r - S = M$$

where:

R_r = Receiver Reading in dBuV

S = Specification Limit in dBuV

M = Margin to Specification in +/- dB

SAMPLE CALCULATIONS - RADIATED EMISSIONS

Receiver readings are compared directly to the specification limit (decibel form). The receiver internally corrects for cable loss, preamplifier gain, and antenna factor. The calculations are in the reverse direction of the actual signal flow, thus cable loss is added and the amplifier gain is subtracted. The Antenna Factor converts the voltage at the antenna coaxial connector to the field strength at the antenna elements.

A distance factor, when used for electric field measurements above 30MHz, is calculated by using the following formula:

$$F_d = 20 * \text{LOG}_{10} (D_m/D_s)$$

where:

F_d = Distance Factor in dB

D_m = Measurement Distance in meters

D_s = Specification Distance in meters

For electric field measurements below 30MHz the extrapolation factor is either determined by making measurements at multiple distances or a theoretical value is calculated using the formula:

$$F_d = 40 * \text{LOG}_{10} (D_m/D_s)$$

Measurement Distance is the distance at which the measurements were taken and Specification Distance is the distance at which the specification limits are based. The antenna factor converts the voltage at the antenna coaxial connector to the field strength

at the antenna elements.

The margin of a given emission peak relative to the limit is calculated as follows:

$$R_c = R_r + F_d$$

and

$$M = R_c - L_s$$

where:

R_r = Receiver Reading in dBuV/m

F_d = Distance Factor in dB

R_c = Corrected Reading in dBuV/m

L_s = Specification Limit in dBuV/m

M = Margin in dB Relative to Spec

SAMPLE CALCULATIONS - FIELD STRENGTH TO EIRP CONVERSION

Where the radiated electric field strength is expressed in terms of the equivalent isotropic radiated power (eirp), or where a field strength measurement of output power is made in lieu of a direct measurement, the following formula is used to convert between eirp and field strength at a distance of d (meters) from the equipment under test:

$$E = \frac{1000000 \sqrt{30 P}}{d} \quad \text{microvolts per meter}$$

where P is the eirp (Watts)

For a measurement at 3m the conversion from a logarithmic value for field strength (dBuV/m) to an eirp power (dBm) is -95.3dB.

Appendix A Test Equipment Calibration Data

<u>Manufacturer</u>	<u>Description</u>	<u>Model</u>	<u>Asset #</u>	<u>Calibrated</u>	<u>Cal Due</u>
Radiated Emissions, 1000 - 6,000 MHz, 23-Feb-15 and 24-Feb-15					
Rohde & Schwarz	EMI Test Receiver, 20 Hz-7 GHz	ESIB7	1538	12/20/2014	12/20/2015
EMCO	Antenna, Horn, 1-18 GHz	3115	1561	6/27/2014	6/27/2016
Radiated Emissions, 1000 - 12,000 MHz, 24-Feb-15 and 25-Feb-15					
Hewlett Packard	Microwave Preamplifier, 1-26.5GHz	8449B	263	3/25/2014	3/25/2015
Hewlett Packard	SpecAn 9 kHz - 40 GHz, FT (SA40) Blue	8564E (84125C)	1393	5/6/2014	5/6/2015
Rohde & Schwarz	EMI Test Receiver, 20 Hz-7 GHz	ESIB7	1538	12/20/2014	12/20/2015
EMCO	Antenna, Horn, 1-18 GHz	3115	1561	6/27/2014	6/27/2016
Hewlett Packard	High Pass filter, 8.2 GHz (Purple System)	P/N 84300-80039	1767	11/14/2014	11/14/2015
Micro-Tronics	Band Reject Filter, 5150-5350 MHz	BRC50703-02	2239	9/16/2014	9/16/2015
Micro-Tronics	Band Reject Filter, 5470-5725 MHz	BRC50704-02	2240	9/16/2014	9/16/2015
Micro-Tronics	Band Reject Filter, 5725-5875 MHz	BRC50705-02	2241	9/16/2014	9/16/2015
Radiated Spurious Emissions, 1000 - 40,000 MHz, 27-Feb-15					
Narda West	High Pass Filter, 8 GHz	HPF 180	821	3/13/2014	3/13/2015
Hewlett Packard	Head (Inc W1-W4, 1946 , 1947) Purple	84125C	1772	1/20/2015	1/20/2016
A. H. Systems	Purple System Horn, 18-40GHz	SAS-574, p/n: 2581	2160	8/11/2014	8/11/2015
Hewlett Packard	Microwave Preamplifier, 1-26.5GHz	8449B	2199	2/20/2015	2/20/2016
Hewlett Packard	SpecAn 9 kHz - 40 GHz, (SA40) Purple	8564E (84125C)	2415	2/27/2014	3/26/2015
EMCO	Antenna, Horn, 1-18 GHz	3115	2870	8/20/2013	8/20/2015
Radio Antenna Port (Power and Spurious Emissions), 02-Mar-15					
Agilent Technologies	PSA, Spectrum Analyzer, (installed options, 111, 115, 123, 1DS, B7J, HYG,	E4446A	2139	4/8/2014	4/8/2015
Radio Antenna Port (Power and Spurious Emissions), 10-Mar-15					
Agilent Technologies	PSA, Spectrum Analyzer, (installed options, 111, 115, 123, 1DS, B7J, HYG,	E4446A	2139	4/8/2014	4/8/2015
Radio Antenna Port (Power and Spurious Emissions), 11-Mar-15					
Agilent Technologies	PSA, Spectrum Analyzer, (installed options, 111, 115, 123, 1DS, B7J, HYG,	E4446A	2139	4/8/2014	4/8/2015
Com-Power	9KHz-30MHz, 50uH, 15Aac, 10Adc, max	LI-215A	2671	5/24/2014	5/24/2015



<u>Manufacturer</u>	<u>Description</u>	<u>Model</u>	<u>Asset #</u>	<u>Calibrated</u>	<u>Cal Due</u>
Radio Antenna Port (Power and Spurious Emissions), 12-Mar-15					
Agilent Technologies	PSA, Spectrum Analyzer, (installed options, 111, 115, 123, 1DS, B7J, HYX,	E4446A	2139	4/8/2014	4/8/2015
Conducted Emissions - AC Power Ports, 03-Sep-14					
Rohde & Schwarz	Pulse Limiter	ESH3 Z2	1401		5/15/2015
Rohde & Schwarz	EMI Test Receiver, 20 Hz-7 GHz	ESIB7	1630		6/21/2015
Fischer Custom Comm	LISN, 25A, 150kHz to 30MHz, 25 Amp,	FCC-LISN-50-25-2-09	2000		4/4/2015

Appendix B Test Data

T97162 Pages 27 – 140

T96173 Pages 141 – 145



EMC Test Data

Client:	Vivint Wireless	Job Number:	J96161
Product:	SR1530 (4x4 5GHz 802.11 AP)	T-Log Number:	T97162
		Project Manager:	Irene Rademacher
Contact:	Venkat Kalkunte	Project Coordinator:	-
Emissions Standard(s):	FCC 15.B / 15.407 (New Rules)	Class:	B
Immunity Standard(s):	-	Environment:	-

EMC Test Data

For The

Vivint Wireless

Product

SR1530 (4x4 5GHz 802.11 AP)

Date of Last Test: 4/9/2015



EMC Test Data

Client: Vivint Wireless	Job Number: J96161
Model: SR1530 (4x4 5GHz 802.11 AP)	T-Log Number: T97162
	Project Manager: Irene Rademacher
Contact: Venkat Kalkunte	Project Coordinator: -
Standard: FCC 15.B / 15.407 (New Rules)	Class: N/A

Power vs. Data Rate

In normal operating modes the card uses power settings stored on EEPROM to set the output power. For a given nominal output power the actual transmit power normally is reduced as the data rate increases, therefore testing was performed at the data rate in the mode with highest power to determine compliance with the requirements.

The following power measurements were made using a **GATED** average power meter and with the device configured in a continuous transmit mode on Chain 1 at the various data rates in each mode to verify the highest power mode:

Sample Notes

Sample S/N: -

Driver: -

Date of Test: 10/16/2014

Test Location: Lab 4

Test Engineer: Mehra n Birgani

Mode	Data Rate	Power (dBm)	Power setting
802.11n 20MHz	6.5	13.8	17.0
	13	13.8	
	19.5	13.7	
	26	13.6	
	39	13.6	
	52	13.6	
	58.5	13.5	
	65	13.5	
	78	13.3	
802.11n/ac 40MHz	13.5	14.6	17.0
	27	14.4	
	40.5	14.4	
	54	14.3	
	81	13.9	
	108	13.7	
	121.5	13.6	
	135	13.4	
	162	13.3	
	180	13.2	

<<-11ac mode only

<<-11ac mode only

<<-11ac mode only

Note : Power setting - the software power setting used during testing, included for reference only.

Client: Vivint Wireless	Job Number: J96161
Model: SR1530 (4x4 5GHz 802.11 AP)	T-Log Number: T97162
	Project Manager: Irene Rademacher
Contact: Venkat Kalkunte	Project Coordinator: -
Standard: FCC 15.B / 15.407 (New Rules)	Class: N/A

Duty Cycle

Duty cycle measurements performed on the worse case data rate for power.

Notes: Measurements taken with maximum RBW/VBW settings allowed.

Mode	Data Rate	Duty Cycle (x)	Constant DC?	T (ms)	Pwr Cor Factor*	Lin Volt Cor Factor**	Min VBW for FS (Hz)
n20	6.5	96.5%	yes	2.54	0.16	0.31	394
n40	13.5	94.3%	yes	1.27	0.26	0.51	787
ac80	MCS8	92.1%	yes	0.58	0.36	0.72	1724

* Correction factor when using RMS/Power averaging - $10 \cdot \log(1/x)$

** Correction factor when using linear voltage average - $20 \cdot \log(1/x)$

T = Minimum transmission duration

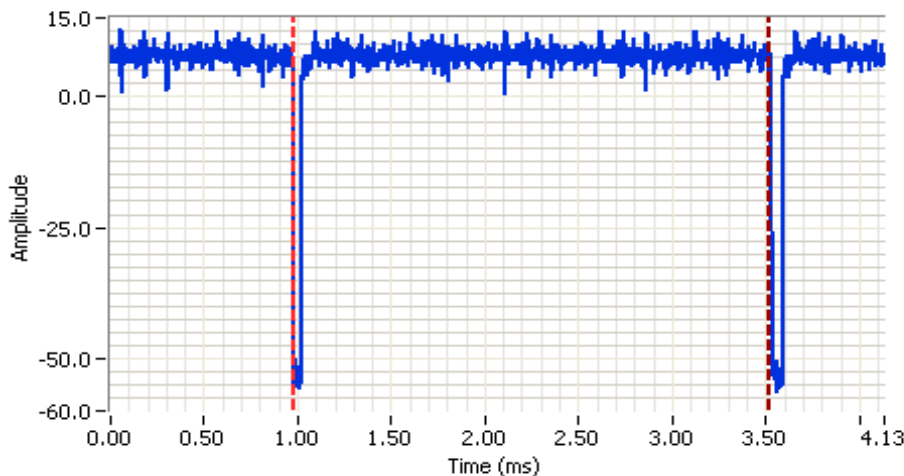

Analyzer Settings

Agilent Technologies, E4446A
 CF: 5500.000 MHz
 SPAN: 0.000 MHz
 RB: 2.000 MHz
 VB: 1.000 MHz
 Detector: POS
 Attn: 20 DB
 RL Offset: 11.5 DB
 Sweep Time: 4.1ms
 Ref Lvl: 20.0 DBM

Comments

802.11n 20MHz MCS8
 On time: 2.45ms
 Cycle time: 2.54ms
 Duty cycle: 96.5%

Cursor 1 0.9790 20.00 Delta Time (ms) 2.539

Cursor 2 3.5180 20.00 Delta Amplitude 0.00

Client: Vivint Wireless	Job Number: J96161
Model: SR1530 (4x4 5GHz 802.11 AP)	T-Log Number: T97162
Contact: Venkat Kalkunte	Project Manager: Irene Rademacher
Standard: FCC 15.B / 15.407 (New Rules)	Project Coordinator: -
	Class: N/A

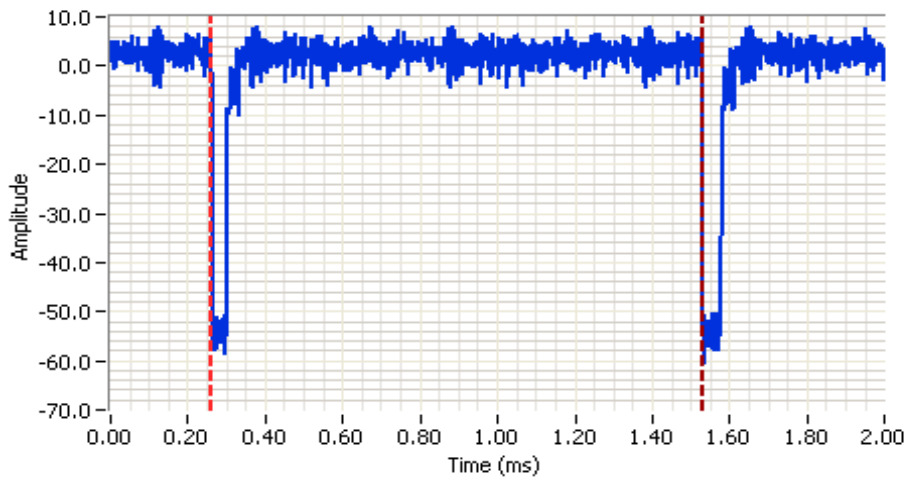

Analyzer Settings
 Agilent Technologies, E4446A
 CF: 5510.000 MHz
 SPAN: 0.000 MHz
 RB: 2.000 MHz
 VB: 1.000 MHz
 Detector: POS
 Attn: 20 DB
 RL Offset: 11.5 DB
 Sweep Time: 2.0ms
 Ref Lvl: 20.0 DBM

Comments
 802.11n 40MHz MCS8
 On time: 1.20
 Cycle time: 1.27ms
 Duty cycle: 94.3%

Cursor 1 0.2603 12.00  Delta Time (ms) 1.270
 Cursor 2 1.5305 12.00  Delta Amplitude 0.00

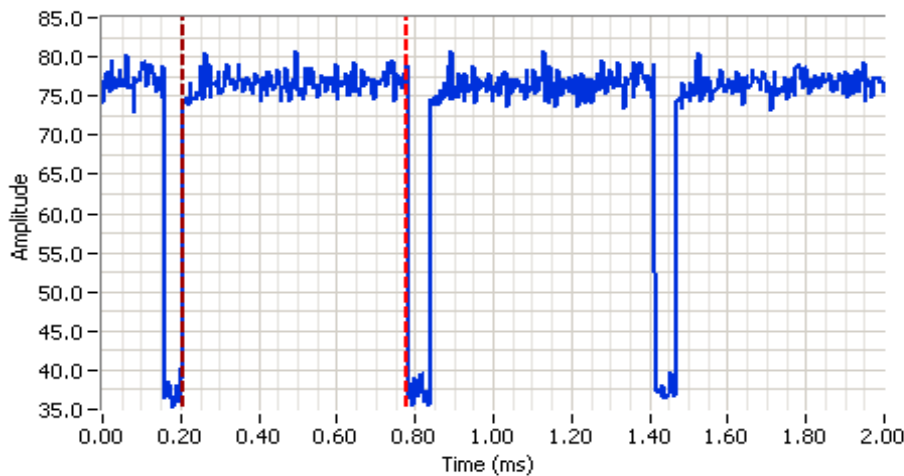

Analyzer Settings
 Rohde&Schwarz, ESI
 CF: 5210.000 MHz
 SPAN: 0.000 MHz
 RB: 5.000 MHz
 VB: 5.000 MHz
 Detector: POS
 Attn: 10 DB
 RL Offset: 0.0 DB
 Sweep Time: 2.0ms
 Ref Lvl: 83.5 DBUv

Comments
 802.11ac MCS8
 On time: 0.58ms
 Off time: 0.05ms
 Duty cycle: 92.1 %

Cursor 1 0.7794 100.00  Delta Time (ms) 0.58
 Cursor 2 0.2041 100.00  Delta Amplitude 0.00





EMC Test Data

Client: Vivint Wireless	Job Number: J96161
Model: SR1530 (4x4 5GHz 802.11 AP)	T-Log Number: T97162
	Project Manager: Irene Rademacher
Contact: Venkat Kalkunte	Project Coordinator: -
Standard: FCC 15.B / 15.407 (New Rules)	Class: N/A

RSS 210 and FCC 15.407 (UNII) Radiated Spurious Emissions

Test Specific Details

Objective: The objective of this test session is to perform final qualification testing of the EUT with respect to the specification listed above.

General Test Configuration

The EUT and all local support equipment were located on the turntable for radiated spurious emissions testing. For radiated emissions testing the measurement antenna was located 3 meters from the EUT, unless otherwise noted.

Ambient Conditions:

Temperature: 23 °C
Rel. Humidity: 40 %

Summary of Results

Run #	Mode	Channel	Target Power Setting	Passing Power Setting	Test Performed	Limit	Result / Margin
1	n20	36 - 5180MHz	-	21	Restricted Band Edge at 5150 MHz	15.209	53.7 dBµV/m @ 5150.0 MHz (-0.3 dB)
	n20	40 - 5200MHz	-	21	Restricted Band Edge at 5150 MHz	15.209	48.9 dBµV/m @ 5150.0 MHz (-5.1 dB)
2	n20	64 - 5320MHz	-	18	Restricted Band Edge at 5350 MHz	15.209	53.2 dBµV/m @ 5350.0 MHz (-0.8 dB)
3	n20	100 - 5500MHz	-	20	Restricted Band Edge at 5460 MHz	15.209	52.8 dBµV/m @ 5460.0 MHz (-1.2 dB)
					Band Edge 5460 - 5470 MHz	15E	67.7 dBµV/m @ 5467.4 MHz (-0.6 dB)
	n20	140 - 5700MHz	-	17	Band Edge 5725MHz	15E	53.5 dBµV/m @ 5725.0 MHz (-0.5 dB)
4	n20	149 - 5745MHz	-	19	Band Edge 5725MHz	15E	76.5 dBµV/m @ 5724.9 MHz (-1.8 dB)
	n20				Band Edge 5715MHz	15E	65.9 dBµV/m @ 5711.4 MHz (-2.4 dB)
	n20	165 - 5825MHz	-	20	Band Edge 5850MHz	15E	77.1 dBµV/m @ 5850.2 MHz (-1.2 dB)
	n20				Band Edge 5860MHz	15E	67.1 dBµV/m @ 5862.8 MHz (-1.2 dB)



EMC Test Data

Client: Vivint Wireless	Job Number: J96161
Model: SR1530 (4x4 5GHz 802.11 AP)	T-Log Number: T97162
	Project Manager: Irene Rademacher
Contact: Venkat Kalkunte	Project Coordinator: -
Standard: FCC 15.B / 15.407 (New Rules)	Class: N/A

Modifications Made During Testing

No modifications were made to the EUT during testing

Deviations From The Standard

No deviations were made from the requirements of the standard.

Procedure Comments:

Measurements performed in accordance with FCC KDB 789033

Peak measurements performed with: RBW=1MHz, VBW=3MHz, peak detector, max hold, auto sweep time

Unless otherwise stated/noted, emission has duty cycle $\geq 98\%$ and was measured using RBW=1MHz, VBW=10Hz, peak detector, linear average mode, auto sweep time, max hold.

Mode	Data Rate	Duty Cycle (x)	Constant DC?	T (ms)	Pwr Cor Factor*	Lin Volt Cor Factor**	Min VBW for FS (Hz)
n20	MCS8	97.0%	yes	2.54	0.13	0.26	394

Sample Notes

Sample S/N: Prototype

Driver: -

Antenna: 6 dBi

Measurement Specific Notes:

Note 1:	For emissions outside of the restricted bands the limit is -27dBm/MHz eirp (68.3dBuV/m). The measurement method required is a peak measurement (RB=1MHz, VB \geq 3MHz, peak detector). Per KDB 789033 II) G) 2) c), compliance can be demonstrated by meeting the average and peak limits of 15.209, as an alternative.
Note 3:	Emission has duty cycle < 98%, but constant, average measurement performed: RBW=1MHz, VBW=10Hz, peak detector, linear averaging, auto sweep, trace average 100 * 1/DC traces, measurement corrected by Linear Voltage correction factor
Note 6:	Plots of the average and peak bandedge do not account for any duty cycle correction. Refer to the tabular results for final measurements.



EMC Test Data

Client: Vivint Wireless	Job Number: J96161
Model: SR1530 (4x4 5GHz 802.11 AP)	T-Log Number: T97162
	Project Manager: Irene Rademacher
Contact: Venkat Kalkunte	Project Coordinator: -
Standard: FCC 15.B / 15.407 (New Rules)	Class: N/A

Run #1: Radiated Bandedge Measurements, 5150-5250MHz

Date of Test: 2/23/2015 0:00
 Test Engineer: John Caizzi
 Test Location: Chamber 7

Config. Used: 1
 Config Change: none
 EUT Voltage: PoE

Channel: 36 - 5180 MHz Power Setting: 21
 Tx Chain: 4Tx
 Mode: n20
 Data Rate: MSC8

5150 MHz Band Edge Signal Radiated Field Strength

Frequency MHz	Level dB μ V/m	Pol v/h	FCC 15.209		Detector Pk/QP/Avg	Azimuth degrees	Height meters	Comments
			Limit	Margin				
5150.000	53.5	V	54.0	-0.5	AVG	352	1.92	Note 3
5148.320	66.8	V	74.0	-7.2	PK	352	1.92	
5150.000	53.7	H	54.0	-0.3	AVG	354	2.08	Note 3
5148.720	67.6	H	74.0	-6.4	PK	354	2.08	

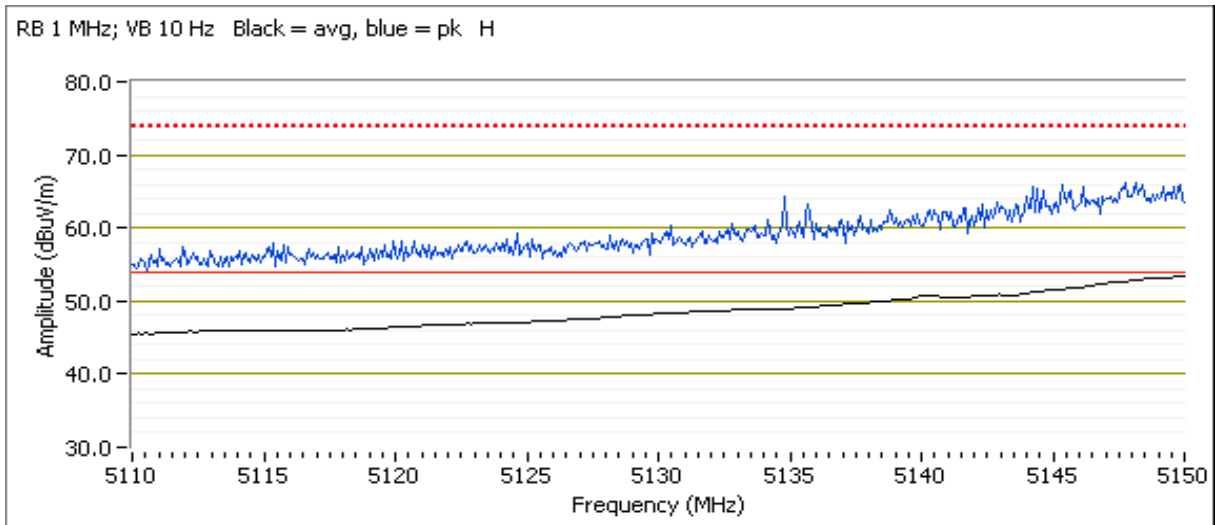



EMC Test Data

Client: Vivint Wireless	Job Number: J96161
Model: SR1530 (4x4 5GHz 802.11 AP)	T-Log Number: T97162
	Project Manager: Irene Rademacher
Contact: Venkat Kalkunte	Project Coordinator: -
Standard: FCC 15.B / 15.407 (New Rules)	Class: N/A

Channel: 40 - 5200 MHz Power Setting: 21
 Tx Chain: 4Tx
 Mode: n20
 Data Rate: MSC8

5150 MHz Band Edge Signal Radiated Field Strength

Frequency MHz	Level dB μ V/m	Pol v/h	FCC 15.209		Detector Pk/QP/Avg	Azimuth degrees	Height meters	Comments
			Limit	Margin				
5149.840	48.0	V	54.0	-6.0	AVG	0	1.83	Note 3
5147.840	59.1	V	74.0	-14.9	PK	0	1.83	
5150.000	48.9	H	54.0	-5.1	AVG	356	1.96	Note 3
5147.760	60.3	H	74.0	-13.7	PK	356	1.96	

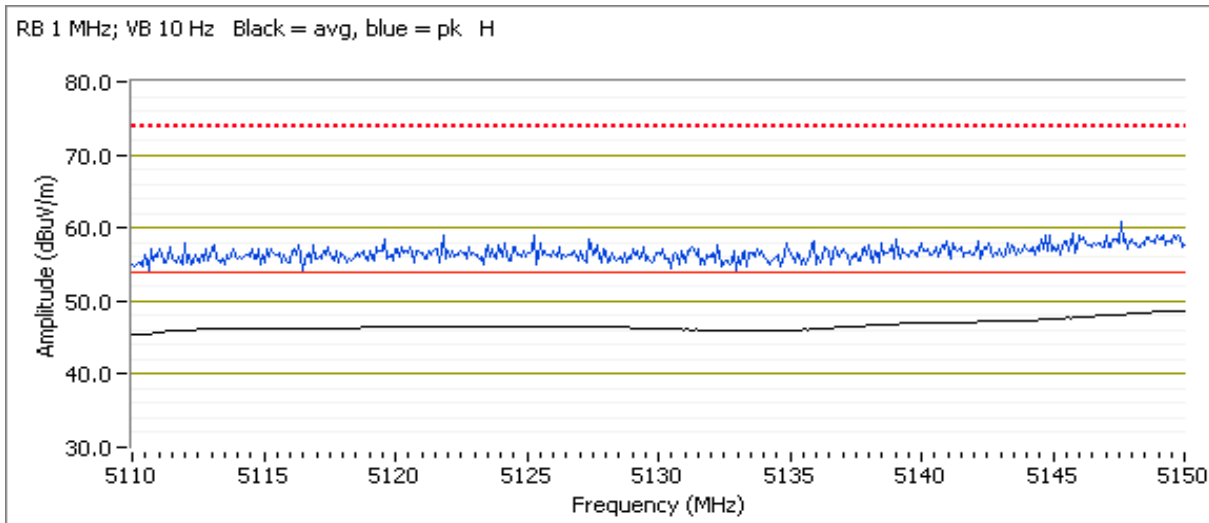



EMC Test Data

Client: Vivint Wireless	Job Number: J96161
Model: SR1530 (4x4 5GHz 802.11 AP)	T-Log Number: T97162
	Project Manager: Irene Rademacher
Contact: Venkat Kalkunte	Project Coordinator: -
Standard: FCC 15.B / 15.407 (New Rules)	Class: N/A

Run #2: Radiated Bandedge Measurements, 5250-5350MHz

Date of Test: 2/23/2015 0:00
 Test Engineer: John Caizzi
 Test Location: Chamber 7

Config. Used: 1
 Config Change: none
 EUT Voltage: PoE

Channel: 64 - 5320MHz Power Setting: 21
 Tx Chain: 4Tx
 Mode: n20
 Data Rate: MSC8

5350 MHz Band Edge Signal Radiated Field Strength

Frequency	Level	Pol	FCC 15.209		Detector	Azimuth	Height	Comments
MHz	dB μ V/m	v/h	Limit	Margin	Pk/QP/Avg	degrees	meters	
5350.000	53.2	H	54.0	-0.8	AVG	360	1.84	Note 3, setting = 18
5350.400	66.7	H	74.0	-7.3	PK	360	1.84	Setting = 18

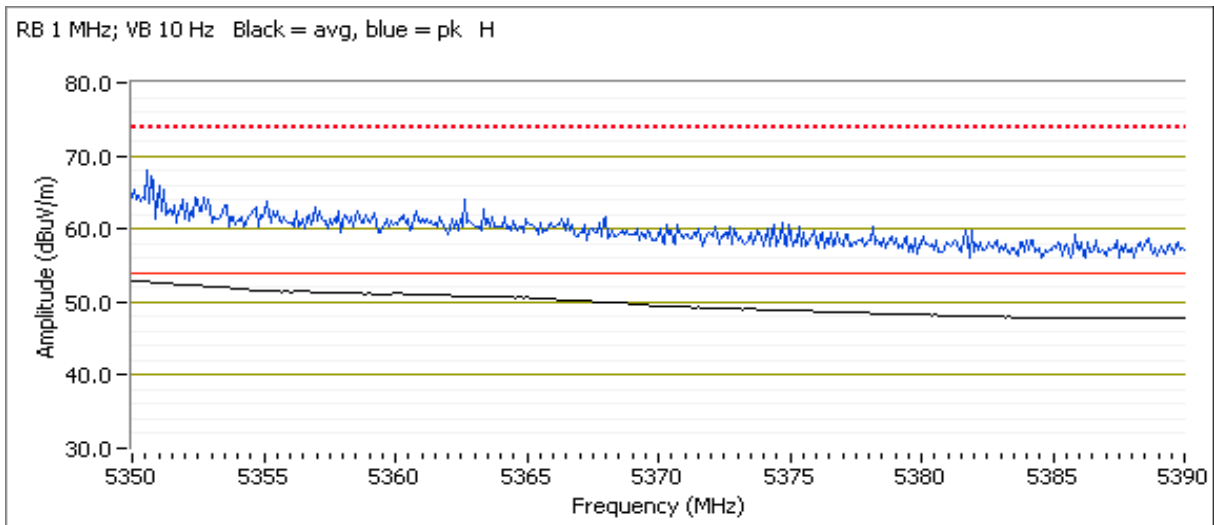



EMC Test Data

Client: Vivint Wireless	Job Number: J96161
Model: SR1530 (4x4 5GHz 802.11 AP)	T-Log Number: T97162
	Project Manager: Irene Rademacher
Contact: Venkat Kalkunte	Project Coordinator: -
Standard: FCC 15.B / 15.407 (New Rules)	Class: N/A

Run #3: Radiated Bandedge Measurements, 5470-5725MHz

Date of Test: 2/23/2015 0:00
 Test Engineer: John Caizzi
 Test Location: Chamber 7

Config. Used: 1
 Config Change: none
 EUT Voltage: PoE

Channel: 100 - 5500MHz
 Tx Chain: 4Tx
 Mode: n20
 Data Rate: MSC8
 Power Setting: 20

5460 MHz Band Edge Signal Radiated Field Strength

Frequency MHz	Level dB μ V/m	Pol v/h	FCC 15.209		Detector Pk/QP/Avg	Azimuth degrees	Height meters	Comments
			Limit	Margin				
5460.000	52.0	V	54.0	-2.0	AVG	347	1.66	Note 3
5459.840	63.7	V	74.0	-10.3	PK	347	1.66	
5460.000	52.8	H	54.0	-1.2	AVG	352	1.65	Note 3
5459.920	65.5	H	74.0	-8.5	PK	352	1.65	

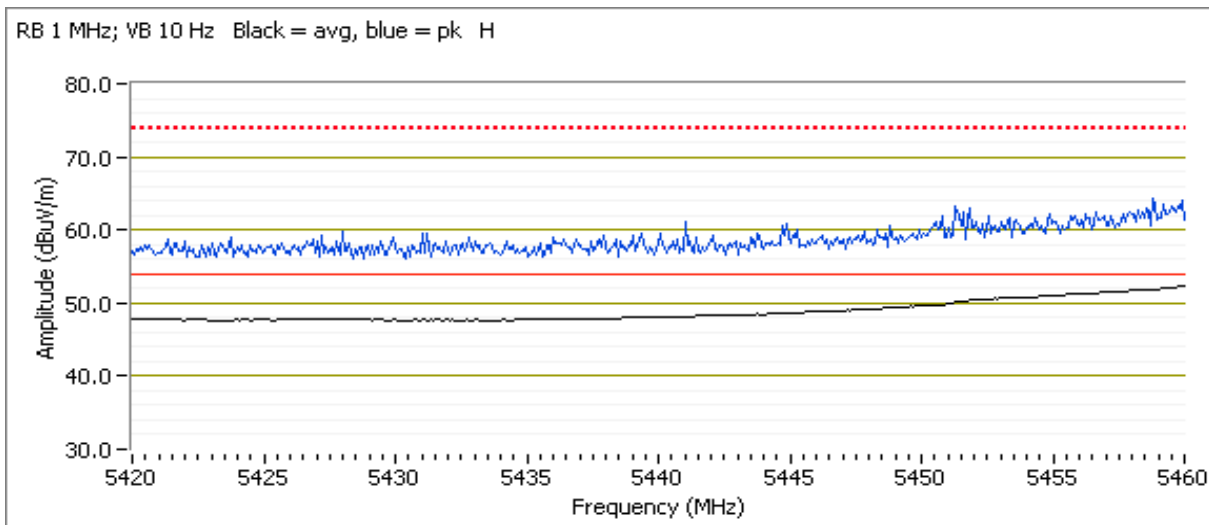



EMC Test Data

Client: Vivint Wireless	Job Number: J96161
Model: SR1530 (4x4 5GHz 802.11 AP)	T-Log Number: T97162
	Project Manager: Irene Rademacher
Contact: Venkat Kalkunte	Project Coordinator: -
Standard: FCC 15.B / 15.407 (New Rules)	Class: N/A

5470 MHz Band Edge Signal Radiated Field Strength

Frequency	Level	Pol	15.E		Detector	Azimuth	Height	Comments
MHz	dB μ V/m	v/h	Limit	Margin	Pk/QP/Avg	degrees	meters	
5467.420	67.7	V	68.3	-0.6	PK	358	1.75	Setting = 20

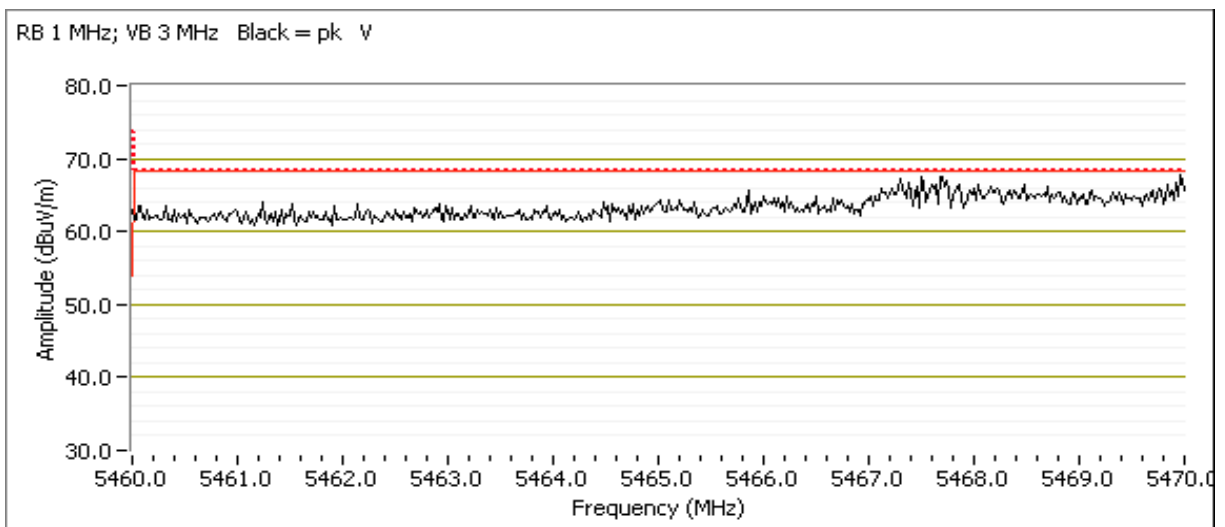



EMC Test Data

Client: Vivint Wireless	Job Number: J96161
Model: SR1530 (4x4 5GHz 802.11 AP)	T-Log Number: T97162
Contact: Venkat Kalkunte	Project Manager: Irene Rademacher
Standard: FCC 15.B / 15.407 (New Rules)	Project Coordinator: -
	Class: N/A

Channel: 140- 5700MHz Power Setting: 17
 Tx Chain: 4Tx
 Mode: n20
 Data Rate: MSC8

5725 MHz Band Edge Signal Radiated Field Strength

Frequency	Level	Pol	15.E		Detector	Azimuth	Height	Comments
MHz	dB μ V/m	v/h	Limit	Margin	Pk/QP/Avg	degrees	meters	
5725.000	53.5	V	54.0	-0.5	AVG	7	1.65	Note 1, 3, setting = 17
5725.960	69.1	V	74.0	-4.9	PK	7	1.65	Note 1, Setting = 17

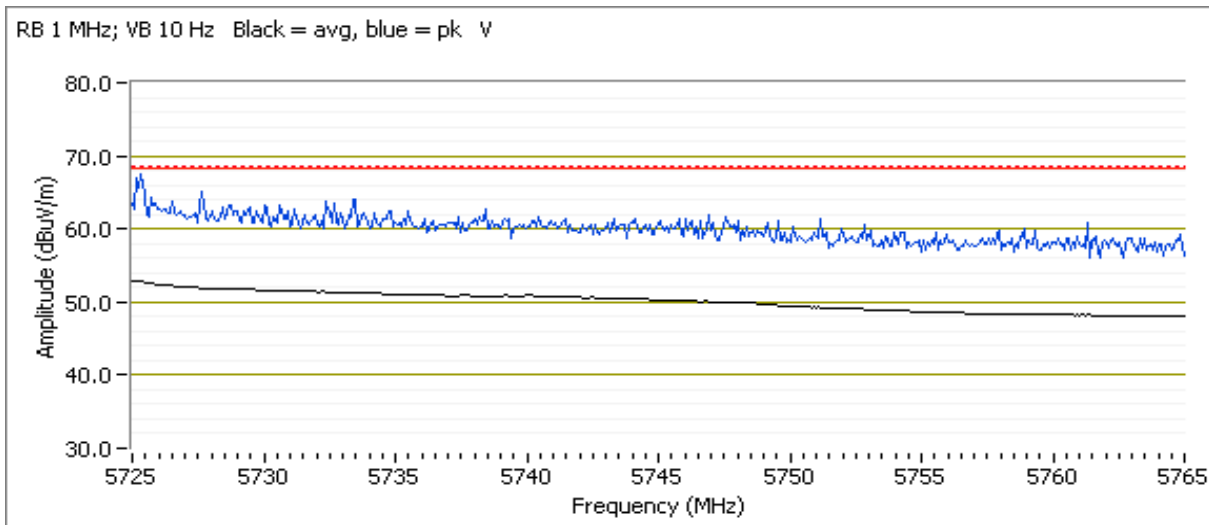



EMC Test Data

Client: Vivint Wireless	Job Number: J96161
Model: SR1530 (4x4 5GHz 802.11 AP)	T-Log Number: T97162
	Project Manager: Irene Rademacher
Contact: Venkat Kalkunte	Project Coordinator: -
Standard: FCC 15.B / 15.407 (New Rules)	Class: N/A

Run #4: Radiated Bandedge Measurements, 5725-5850MHz

Date of Test: 2/23/2015 0:00
 Test Engineer: Rafael Varelas
 Test Location: FT Chamber #7

Config. Used: 1
 Config Change: None
 EUT Voltage: PoE

Channel: 149 - 5745MHz Power Setting: 19
 Tx Chain: 4Tx
 Mode: n20
 Data Rate: MSC8

5725 MHz Band Edge Signal Radiated Field Strength

Frequency MHz	Level dB μ V/m	Pol v/h	15.E		Detector Pk/QP/Avg	Azimuth degrees	Height meters	Comments
			Limit	Margin				
5724.940	76.5	H	78.3	-1.8	PK	0	2.0	pwr setting = 19
5724.640	73.5	V	78.3	-4.8	PK	352	2.0	pwr setting = 19

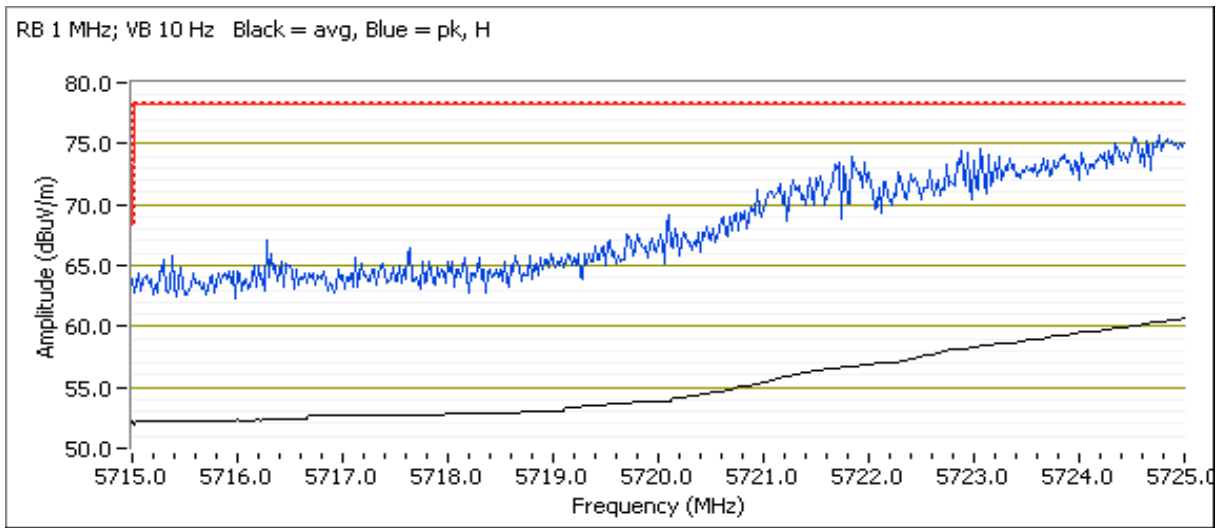



EMC Test Data

Client: Vivint Wireless	Job Number: J96161
Model: SR1530 (4x4 5GHz 802.11 AP)	T-Log Number: T97162
	Project Manager: Irene Rademacher
Contact: Venkat Kalkunte	Project Coordinator: -
Standard: FCC 15.B / 15.407 (New Rules)	Class: N/A

5715 MHz Band Edge Signal Radiated Field Strength

Frequency MHz	Level dB μ V/m	Pol v/h	15.E		Detector Pk/QP/Avg	Azimuth degrees	Height meters	Comments
			Limit	Margin				
5711.390	65.9	H	68.3	-2.4	PK	0	2.0	pwr setting = 19
5711.450	63.5	V	68.3	-4.8	PK	352	2.0	pwr setting = 19

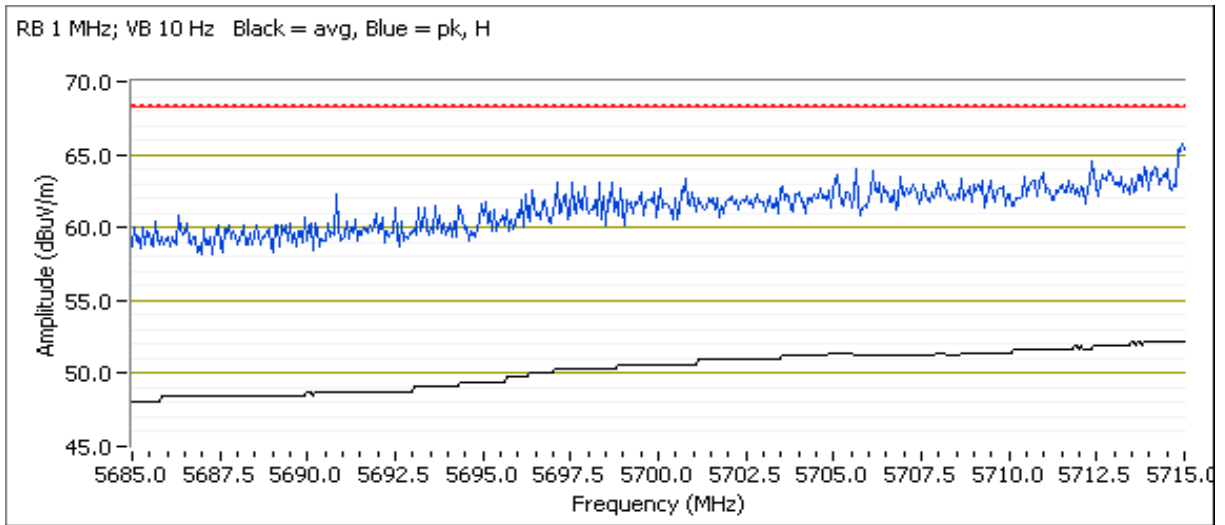

Client: Vivint Wireless	Job Number: J96161
Model: SR1530 (4x4 5GHz 802.11 AP)	T-Log Number: T97162
	Project Manager: Irene Rademacher
Contact: Venkat Kalkunte	Project Coordinator: -
Standard: FCC 15.B / 15.407 (New Rules)	Class: N/A

Channel: 165 - 5825MHz Power Setting: 20
 Tx Chain: 4Tx
 Mode: n20
 Data Rate: MSC8

5850 MHz Band Edge Signal Radiated Field Strength

Frequency	Level	Pol	15.E		Detector	Azimuth	Height	Comments
MHz	dB μ V/m	v/h	Limit	Margin	Pk/QP/Avg	degrees	meters	
5850.180	77.1	V	78.3	-1.2	PK	357	2.0	pwr setting = 20
5850.160	75.2	H	78.3	-3.1	PK	6	2.0	pwr setting = 20

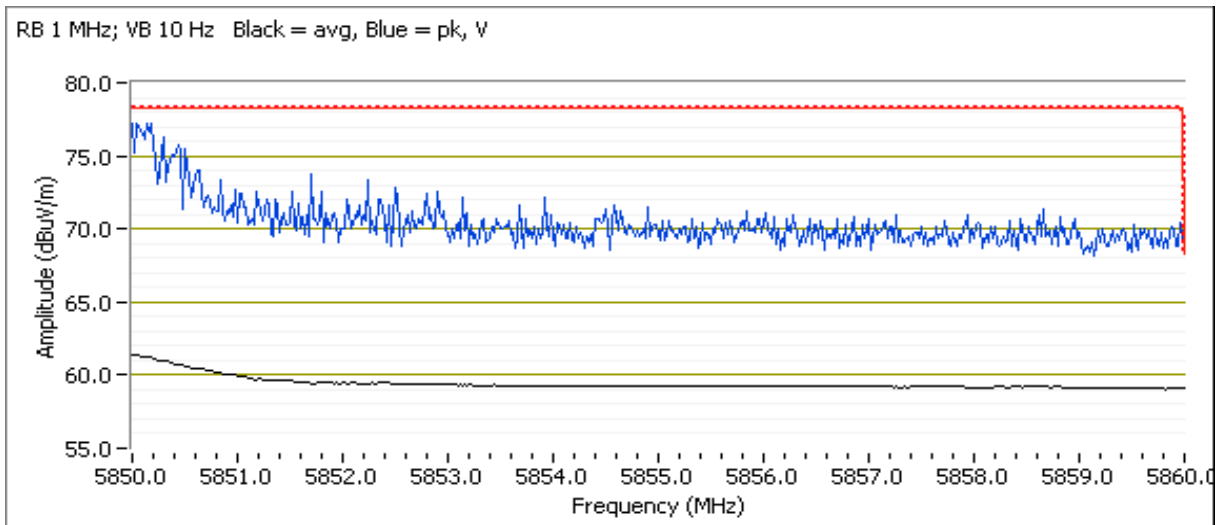



EMC Test Data

Client: Vivint Wireless	Job Number: J96161
Model: SR1530 (4x4 5GHz 802.11 AP)	T-Log Number: T97162
Contact: Venkat Kalkunte	Project Manager: Irene Rademacher
Standard: FCC 15.B / 15.407 (New Rules)	Project Coordinator: -
	Class: N/A

5860 MHz Band Edge Signal Radiated Field Strength

Frequency MHz	Level dB μ V/m	Pol v/h	15.E		Detector Pk/QP/Avg	Azimuth degrees	Height meters	Comments
			Limit	Margin				
5862.770	67.1	V	68.3	-1.2	PK	357	2.0	pwr setting = 20
5863.370	66.7	H	68.3	-1.6	PK	6	2.0	pwr setting = 20

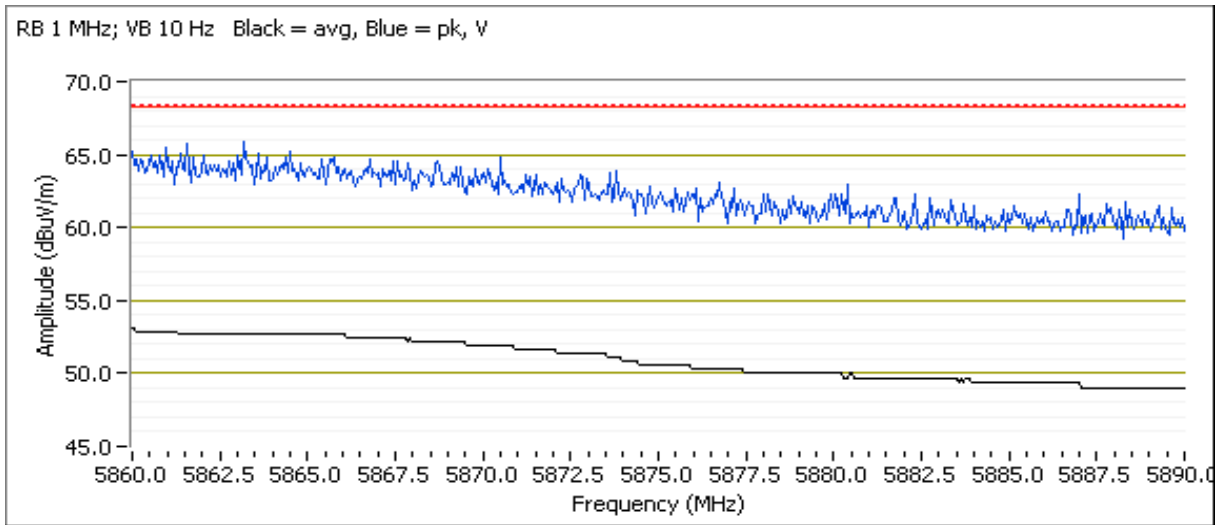



EMC Test Data

Client: Vivint Wireless	Job Number: J96161
Model: SR1530 (4x4 5GHz 802.11 AP)	T-Log Number: T97162
	Project Manager: Irene Rademacher
Contact: Venkat Kalkunte	Project Coordinator: -
Standard: FCC 15.B / 15.407 (New Rules)	Class: N/A

RSS 210 and FCC 15.407 (UNII) Radiated Spurious Emissions

Test Specific Details

Objective: The objective of this test session is to perform final qualification testing of the EUT with respect to the specification listed above.

General Test Configuration

The EUT and all local support equipment were located on the turntable for radiated spurious emissions testing. For radiated emissions testing the measurement antenna was located 3 meters from the EUT, unless otherwise noted.

Ambient Conditions:

Temperature: 21.8 °C
Rel. Humidity: 40 %

Summary of Results

Run #	Mode	Channel	Target Power Setting	Passing Power Setting	Test Performed	Limit	Result / Margin
1	n40	38 - 5190MHz	-	17	Restricted Band Edge at 5150 MHz	15.209	53.7 dBµV/m @ 5150.0 MHz (-0.3 dB)
	n40	46 - 5230MHz	-	21	Restricted Band Edge at 5150 MHz	15.209	49.0 dBµV/m @ 5150.0 MHz (-5.0 dB)
2	n40	62 - 5310MHz	-	16	Restricted Band Edge at 5350 MHz	15.209	52.9 dBµV/m @ 5350.0 MHz (-1.1 dB)
	n40	54 - 5270MHz	-	21	Restricted Band Edge at 5350 MHz	15.209	49.9 dBµV/m @ 5350.0 MHz (-4.1 dB)
3	n40	102 - 5510MHz	-	15	Restricted Band Edge at 5460 MHz	15.209	49.2 dBµV/m @ 5460.0 MHz (-4.8 dB)
	n40	102 - 5510MHz	-	15	Band Edge 5460 - 5470 MHz	15E	67.7 dBµV/m @ 5468.1 MHz (-0.6 dB)
	n40	134 - 5670MHz	-	20	Band Edge 5725MHz	15E	67.2 dBµV/m @ 5726.8 MHz (-1.1 dB)
4	n40	151 - 5755MHz	-	16	Band Edge 5725MHz	15E	76.9 dBµV/m @ 5720.1 MHz (-1.4 dB)
	Band Edge 5715MHz				15E	67.6 dBµV/m @ 5710.8 MHz (-0.7 dB)	
	n40	159 - 5795MHz	-	19	Band Edge 5850MHz	15E	66.6 dBµV/m @ 5851.7 MHz (-11.7 dB)
	n40				Band Edge 5860MHz	15E	65.6 dBµV/m @ 5865.1 MHz (-2.7 dB)



EMC Test Data

Client: Vivint Wireless	Job Number: J96161
Model: SR1530 (4x4 5GHz 802.11 AP)	T-Log Number: T97162
	Project Manager: Irene Rademacher
Contact: Venkat Kalkunte	Project Coordinator: -
Standard: FCC 15.B / 15.407 (New Rules)	Class: N/A

Modifications Made During Testing

No modifications were made to the EUT during testing

Deviations From The Standard

No deviations were made from the requirements of the standard.

Procedure Comments:

Measurements performed in accordance with FCC KDB 789033

Peak measurements performed with: RBW=1MHz, VBW=3MHz, peak detector, max hold, auto sweep time

Unless otherwise stated/noted, emission has duty cycle $\geq 98\%$ and was measured using RBW=1MHz, VBW=10Hz, peak detector, linear average mode, auto sweep time, max hold.

Mode	Data Rate	Duty Cycle (x)	Constant DC?	T (ms)	Pwr Cor Factor*	Lin Volt Cor Factor**	Min VBW for FS (Hz)
n40	13.5	94.3%	yes	1.27	0.26	0.51	787

Sample Notes

Sample S/N: Prototype

Driver: -

Antenna: 6 dBi

Measurement Specific Notes:

Note 1:	For emissions outside of the restricted bands the limit is -27dBm/MHz eirp (68.3dBuV/m). The measurement method required is a peak measurement (RB=1MHz, VB \geq 3MHz, peak detector). Per KDB 789033 II) G) 2) c), compliance can be demonstrated by meeting the average and peak limits of 15.209, as an alternative.
Note 3:	Emission has duty cycle < 98%, but constant, average measurement performed: RBW=1MHz, VBW=10Hz, peak detector, linear averaging, auto sweep, trace average 100 * 1/DC traces, measurement corrected by Linear Voltage correction factor
Note 6:	Plots of the average and peak bandedge do not account for any duty cycle correction. Refer to the tabluar results for final measurements.



EMC Test Data

Client: Vivint Wireless	Job Number: J96161
Model: SR1530 (4x4 5GHz 802.11 AP)	T-Log Number: T97162
	Project Manager: Irene Rademacher
Contact: Venkat Kalkunte	Project Coordinator: -
Standard: FCC 15.B / 15.407 (New Rules)	Class: N/A

Run #1: Radiated Bandedge Measurements, 5150-5250MHz

Date of Test: 2/23/2015 0:00
 Test Engineer: Rafael Varelas
 Test Location: FT Chamber #7

Config. Used: 1
 Config Change: None
 EUT Voltage: PoE

Channel: 38 - 5190 MHz Power Setting: 17
 Tx Chain: 4Tx
 Mode: n40
 Data Rate: MCS8

5150 MHz Band Edge Signal Radiated Field Strength

Frequency MHz	Level dB μ V/m	Pol v/h	FCC 15.209		Detector Pk/QP/Avg	Azimuth degrees	Height meters	Comments
			Limit	Margin				
5150.000	53.7	V	54.0	-0.3	AVG	354	1.9	pwr setting = 17, Note 3
5149.040	69.4	V	74.0	-4.6	PK	354	1.9	pwr setting = 17
5150.000	52.7	H	54.0	-1.3	AVG	344	2.2	pwr setting = 17, Note 3
5145.990	73.1	H	74.0	-0.9	PK	344	2.2	pwr setting = 17

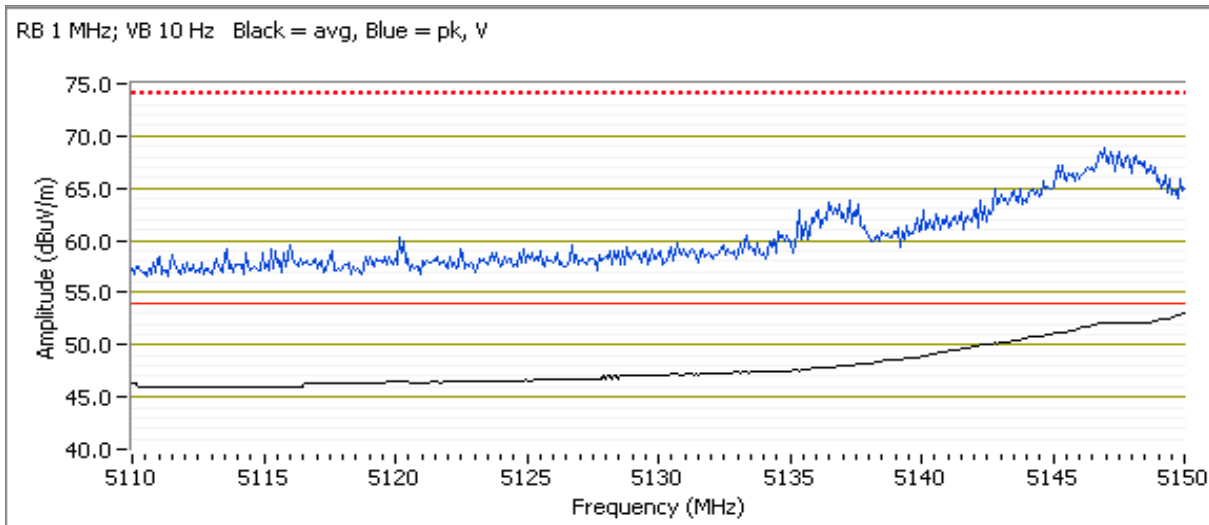



EMC Test Data

Client: Vivint Wireless	Job Number: J96161
Model: SR1530 (4x4 5GHz 802.11 AP)	T-Log Number: T97162
	Project Manager: Irene Rademacher
Contact: Venkat Kalkunte	Project Coordinator: -
Standard: FCC 15.B / 15.407 (New Rules)	Class: N/A

Channel: 46 - 5230 MHz Power Setting: 21
 Tx Chain: 4Tx
 Mode: n40
 Data Rate: MCS8

5150 MHz Band Edge Signal Radiated Field Strength

Frequency MHz	Level dB μ V/m	Pol v/h	FCC 15.209		Detector Pk/QP/Avg	Azimuth degrees	Height meters	Comments
			Limit	Margin				
5150.000	49.0	V	54.0	-5.0	AVG	355	1.9	Note 3
5143.830	62.0	V	74.0	-12.0	PK	355	1.9	
5150.000	49.0	H	54.0	-5.0	AVG	360	1.5	Note 3
5147.920	61.4	H	74.0	-12.6	PK	360	1.5	

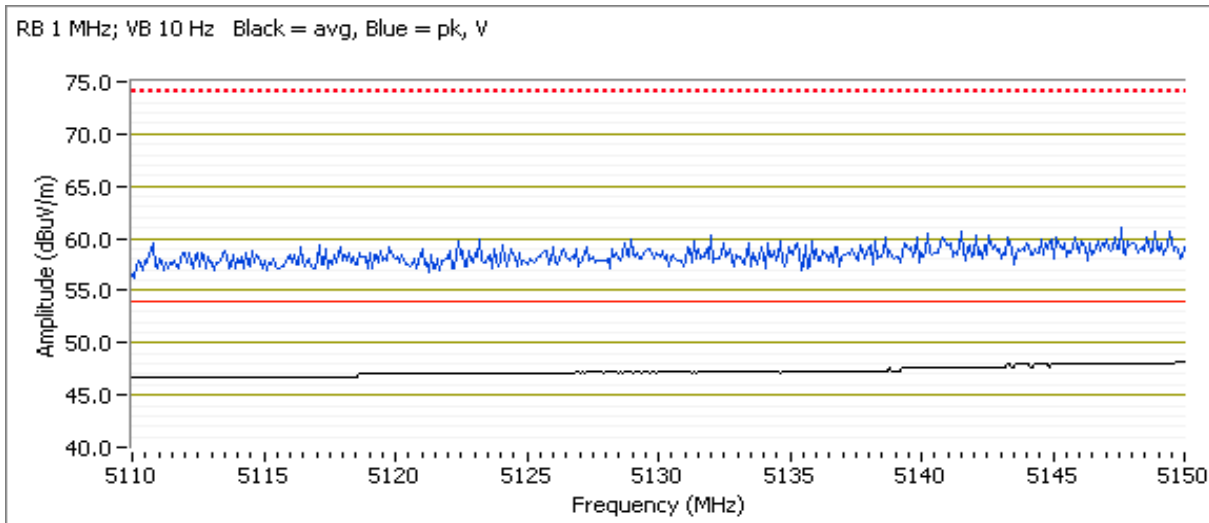



EMC Test Data

Client: Vivint Wireless	Job Number: J96161
Model: SR1530 (4x4 5GHz 802.11 AP)	T-Log Number: T97162
	Project Manager: Irene Rademacher
Contact: Venkat Kalkunte	Project Coordinator: -
Standard: FCC 15.B / 15.407 (New Rules)	Class: N/A

Run #2: Radiated Bandedge Measurements, 5250-5350MHz

Date of Test: 2/23/2015 0:00
 Test Engineer: Rafael Varelas
 Test Location: FT Chamber #7

Config. Used: 1
 Config Change: None
 EUT Voltage: PoE

Channel: 62 - 5310MHz
 Tx Chain: 4Tx
 Mode: n40
 Data Rate: MCS8

Power Setting: 16

5350 MHz Band Edge Signal Radiated Field Strength

Frequency MHz	Level dB μ V/m	Pol v/h	FCC 15.209		Detector Pk/QP/Avg	Azimuth degrees	Height meters	Comments
			Limit	Margin				
5350.000	52.9	H	54.0	-1.1	AVG	0	2.0	pwr setting = 16, Note 3
5350.000	72.0	H	74.0	-2.0	PK	0	2.0	pwr setting = 16
5350.000	50.6	V	54.0	-3.4	AVG	348	1.9	pwr setting = 16, Note 3
5350.560	64.7	V	74.0	-9.3	PK	348	1.9	pwr setting = 16

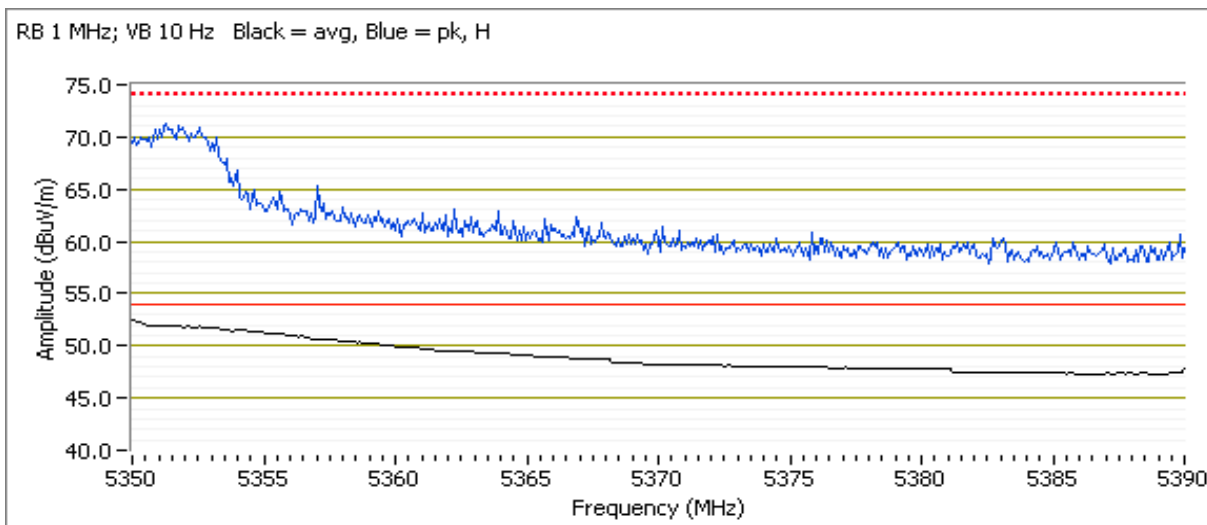



EMC Test Data

Client: Vivint Wireless	Job Number: J96161
Model: SR1530 (4x4 5GHz 802.11 AP)	T-Log Number: T97162
	Project Manager: Irene Rademacher
Contact: Venkat Kalkunte	Project Coordinator: -
Standard: FCC 15.B / 15.407 (New Rules)	Class: N/A

Channel: 54 - 5270MHz Power Setting: 21
 Tx Chain: 4Tx
 Mode: n40
 Data Rate: MCS8

5350 MHz Band Edge Signal Radiated Field Strength

Frequency	Level	Pol	FCC 15.209		Detector	Azimuth	Height	Comments
MHz	dB μ V/m	v/h	Limit	Margin	Pk/QP/Avg	degrees	meters	
5350.000	49.9	H	54.0	-4.1	AVG	360	1.8	Note 3
5355.770	60.9	H	74.0	-13.1	PK	360	1.8	
5350.080	49.1	V	54.0	-4.9	AVG	360	1.6	Note 3
5363.630	60.5	V	74.0	-13.5	PK	360	1.6	

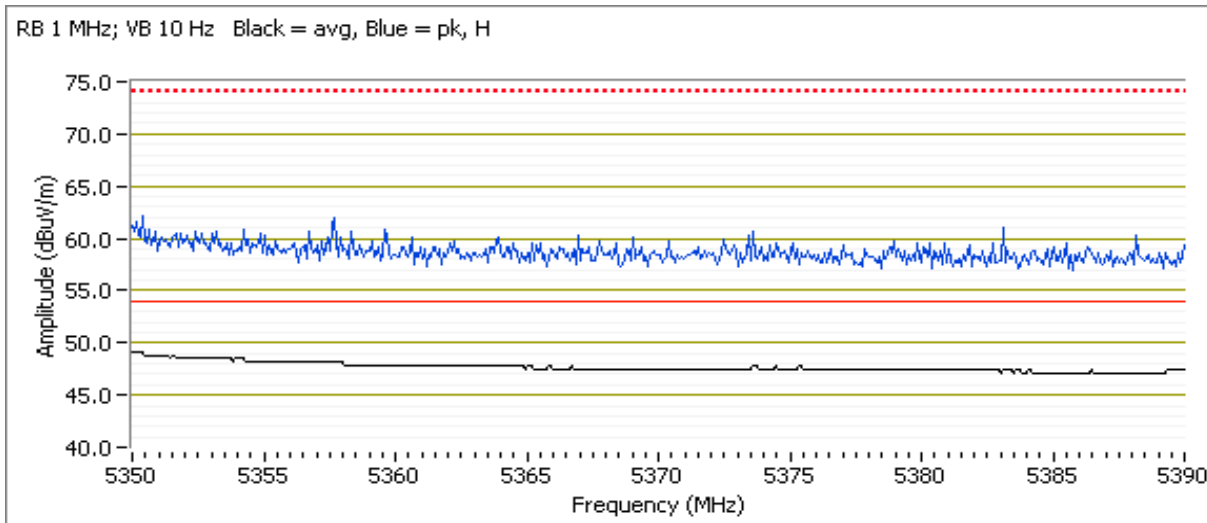



EMC Test Data

Client: Vivint Wireless	Job Number: J96161
Model: SR1530 (4x4 5GHz 802.11 AP)	T-Log Number: T97162
	Project Manager: Irene Rademacher
Contact: Venkat Kalkunte	Project Coordinator: -
Standard: FCC 15.B / 15.407 (New Rules)	Class: N/A

Run #3: Radiated Bandedge Measurements, 5470-5725MHz

Date of Test: 2/23/2015 0:00
 Test Engineer: Rafael Varelas
 Test Location: FT Chamber #7

Config. Used: 1
 Config Change: None
 EUT Voltage: PoE

Channel: 102 - 5510MHz Power Setting: 15
 Tx Chain: 4Tx
 Mode: n40
 Data Rate: MCS8

5460 MHz Band Edge Signal Radiated Field Strength

Frequency MHz	Level dB μ V/m	Pol v/h	FCC 15.209		Detector Pk/QP/Avg	Azimuth degrees	Height meters	Comments
			Limit	Margin				
5460.000	49.2	H	54.0	-4.8	AVG	360	2.0	pwr setting = 15, Note 3
5459.040	60.7	H	74.0	-13.3	PK	360	2.0	pwr setting = 15
5460.000	48.2	V	54.0	-5.8	AVG	10	2.0	pwr setting = 15, Note 3
5456.230	59.9	V	74.0	-14.1	PK	10	2.0	pwr setting = 15

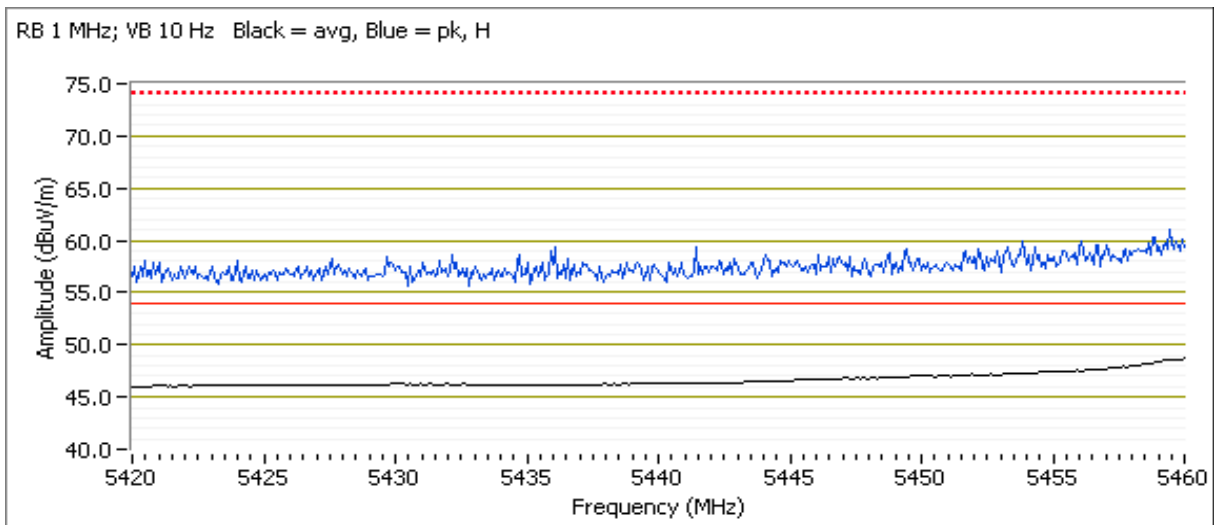



EMC Test Data

Client: Vivint Wireless	Job Number: J96161
Model: SR1530 (4x4 5GHz 802.11 AP)	T-Log Number: T97162
	Project Manager: Irene Rademacher
Contact: Venkat Kalkunte	Project Coordinator: -
Standard: FCC 15.B / 15.407 (New Rules)	Class: N/A

5470 MHz Band Edge Signal Radiated Field Strength

Frequency MHz	Level dB μ V/m	Pol v/h	15.E		Detector Pk/QP/Avg	Azimuth degrees	Height meters	Comments
			Limit	Margin				
5468.120	67.7	H	68.3	-0.6	PK	360	2.0	pwr setting = 15
5463.550	64.1	V	68.3	-4.2	PK	10	2.0	pwr setting = 15

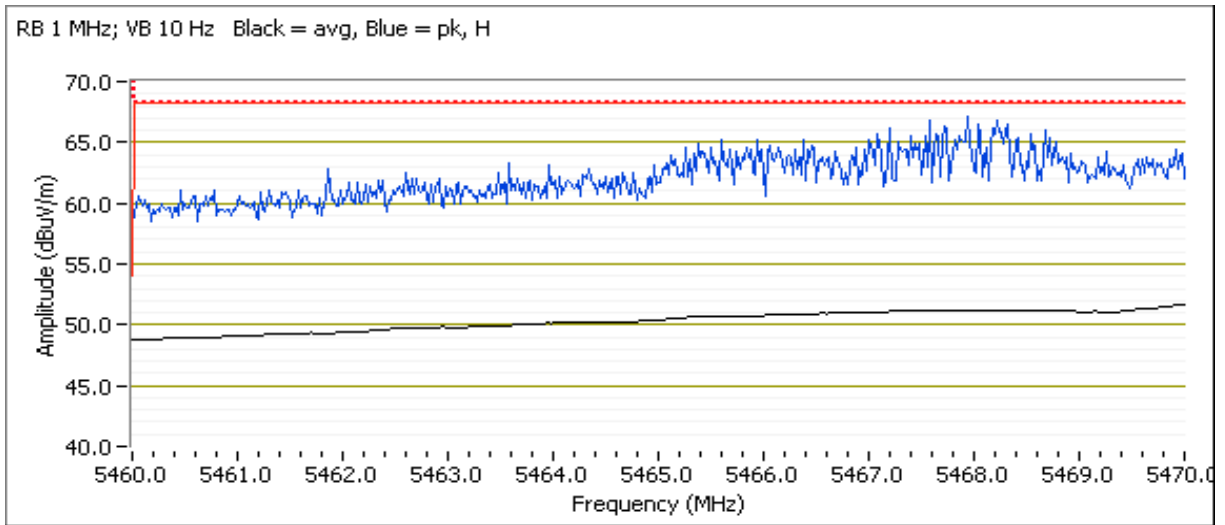



EMC Test Data

Client: Vivint Wireless	Job Number: J96161
Model: SR1530 (4x4 5GHz 802.11 AP)	T-Log Number: T97162
	Project Manager: Irene Rademacher
Contact: Venkat Kalkunte	Project Coordinator: -
Standard: FCC 15.B / 15.407 (New Rules)	Class: N/A

Channel: 134 - 5670MHz
 Tx Chain: 4Tx
 Mode: n40
 Data Rate: MCS8

5725 MHz Band Edge Signal Radiated Field Strength

Frequency MHz	Level dB μ V/m	Pol v/h	15.E		Detector Pk/QP/Avg	Azimuth degrees	Height meters	Comments
			Limit	Margin				
5726.840	67.2	H	68.3	-1.1	PK	0	1.8	pwr setting = 20
5726.840	64.6	V	68.3	-3.7	PK	351	2.0	pwr setting = 20

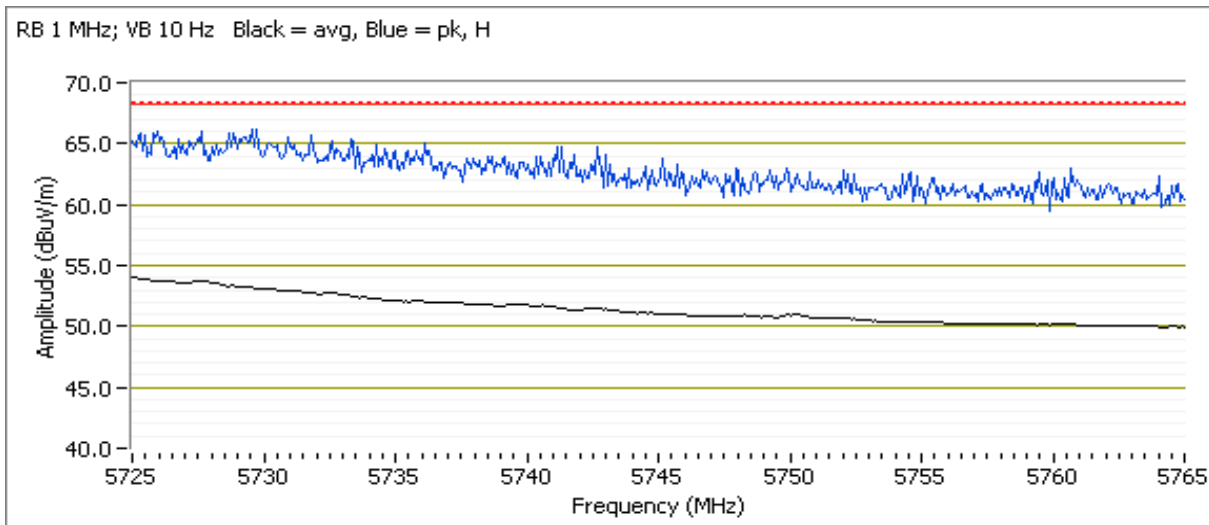



EMC Test Data

Client: Vivint Wireless	Job Number: J96161
Model: SR1530 (4x4 5GHz 802.11 AP)	T-Log Number: T97162
	Project Manager: Irene Rademacher
Contact: Venkat Kalkunte	Project Coordinator: -
Standard: FCC 15.B / 15.407 (New Rules)	Class: N/A

Run #4: Radiated Bandedge Measurements, 5725-5850MHz

Date of Test: 2/24/2015 0:00
 Test Engineer: Jack Liu
 Test Location: FT Chamber# 7

Config. Used: 1
 Config Change: -
 EUT Voltage: PoE

Channel: 151 - 5755MHz
 Tx Chain: 4Tx
 Mode: n40
 Data Rate: MCS8

5725 MHz Band Edge Signal Radiated Field Strength

Frequency	Level	Pol	15.E		Detector	Azimuth	Height	Comments
MHz	dB μ V/m	v/h	Limit	Margin	Pk/QP/Avg	degrees	meters	
Pwr setting 16								
5720.050	76.9	H	78.3	-1.4	PK	6	1.8	POS; RB 1 MHz; VB: 3 MHz
5721.990	72.8	V	78.3	-5.5	PK	8	1.5	POS; RB 1 MHz; VB: 3 MHz

Client: Vivint Wireless	Job Number: J96161
Model: SR1530 (4x4 5GHz 802.11 AP)	T-Log Number: T97162
	Project Manager: Irene Rademacher
Contact: Venkat Kalkunte	Project Coordinator: -
Standard: FCC 15.B / 15.407 (New Rules)	Class: N/A

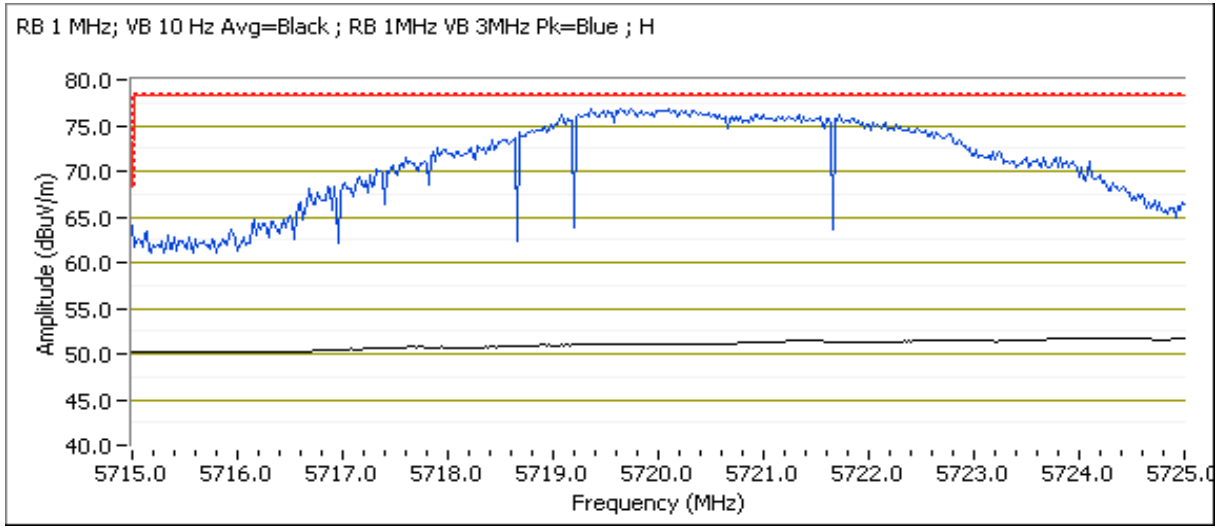



EMC Test Data

Client: Vivint Wireless	Job Number: J96161
Model: SR1530 (4x4 5GHz 802.11 AP)	T-Log Number: T97162
Contact: Venkat Kalkunte	Project Manager: Irene Rademacher
Standard: FCC 15.B / 15.407 (New Rules)	Project Coordinator: -
	Class: N/A

5715 MHz Band Edge Signal Radiated Field Strength

Frequency	Level	Pol	15.E		Detector	Azimuth	Height	Comments
MHz	dB μ V/m	v/h	Limit	Margin	PK/QP/Avg	degrees	meters	
Pwr setting 16								
5710.790	67.6	H	68.3	-0.7	PK	352	1.8	POS; RB 1 MHz; VB: 3 MHz
5711.150	66.7	V	68.3	-1.6	PK	349	1.7	POS; RB 1 MHz; VB: 3 MHz

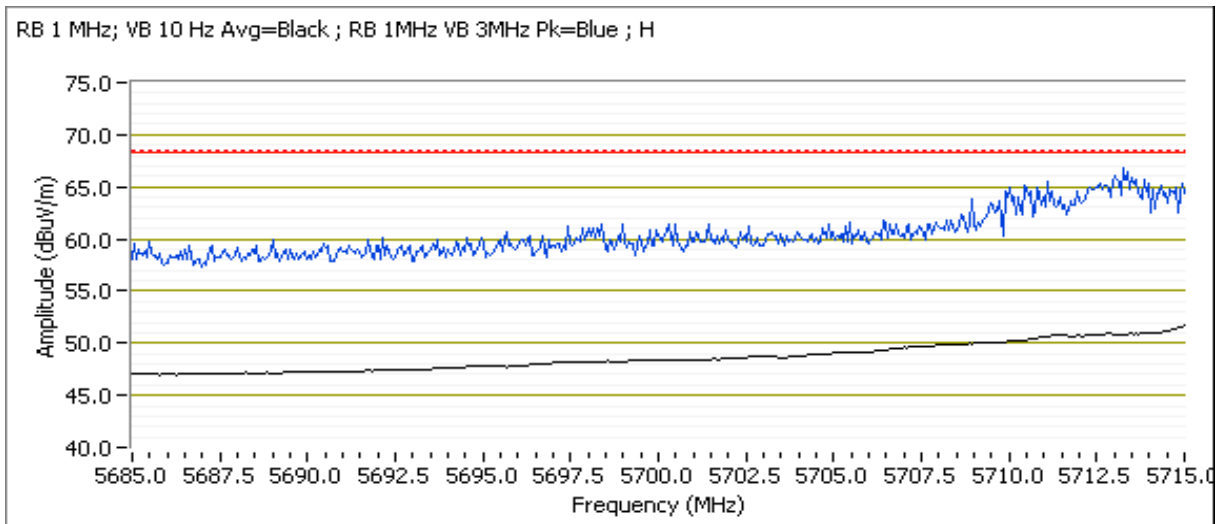



EMC Test Data

Client: Vivint Wireless	Job Number: J96161
Model: SR1530 (4x4 5GHz 802.11 AP)	T-Log Number: T97162
	Project Manager: Irene Rademacher
Contact: Venkat Kalkunte	Project Coordinator: -
Standard: FCC 15.B / 15.407 (New Rules)	Class: N/A

Channel: 159 - 5795MHz
 Tx Chain: 4Tx
 Mode: n40
 Data Rate: MCS8

5850 MHz Band Edge Signal Radiated Field Strength

Frequency	Level	Pol	15.E		Detector	Azimuth	Height	Comments
MHz	dB μ V/m	v/h	Limit	Margin	Pk/QP/Avg	degrees	meters	
Pwr setting 19								
5851.720	66.6	H	78.3	-11.7	PK	360	1.5	POS; RB 1 MHz; VB: 3 MHz
5854.850	65.7	V	78.3	-12.6	PK	0	1.6	POS; RB 1 MHz; VB: 3 MHz

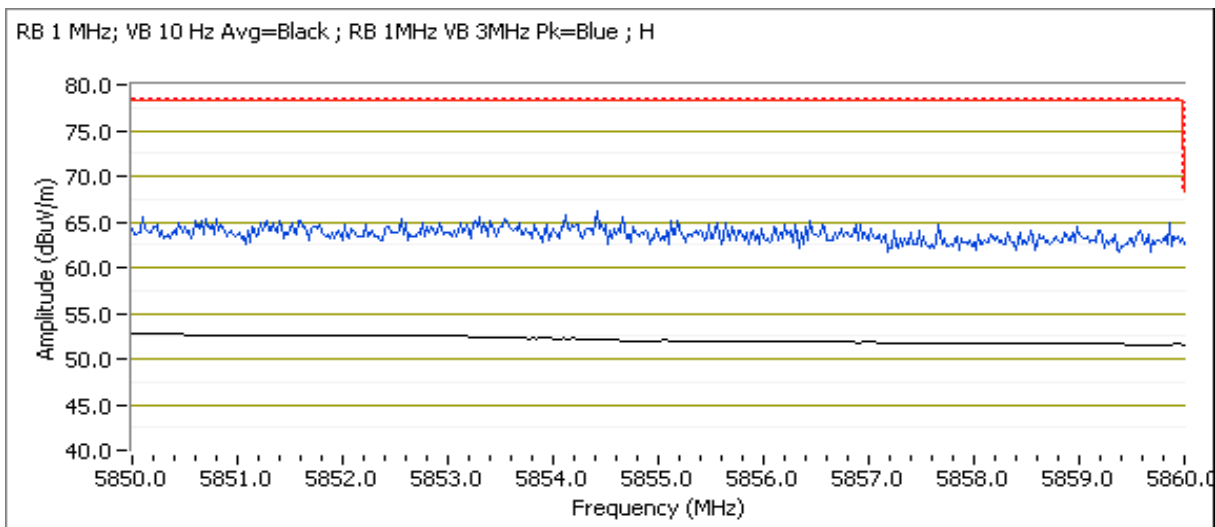



EMC Test Data

Client: Vivint Wireless	Job Number: J96161
Model: SR1530 (4x4 5GHz 802.11 AP)	T-Log Number: T97162
Contact: Venkat Kalkunte	Project Manager: Irene Rademacher
Standard: FCC 15.B / 15.407 (New Rules)	Project Coordinator: -
	Class: N/A

5860 MHz Band Edge Signal Radiated Field Strength

Frequency	Level	Pol	15.E		Detector	Azimuth	Height	Comments
MHz	dB μ V/m	v/h	Limit	Margin	Pk/QP/Avg	degrees	meters	
Pwr setting 19								
5865.110	65.6	V	68.3	-2.7	PK	0	1.5	POS; RB 1 MHz; VB: 3 MHz
5860.780	65.1	H	68.3	-3.2	PK	355	1.8	POS; RB 1 MHz; VB: 3 MHz

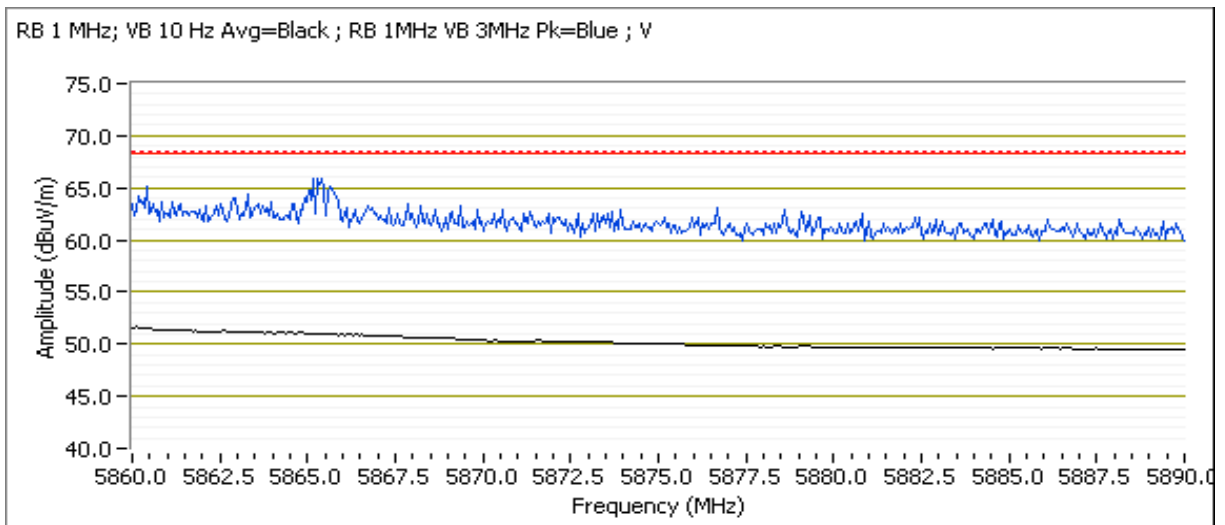



EMC Test Data

Client: Vivint Wireless	Job Number: J96161
Model: SR1530 (4x4 5GHz 802.11 AP)	T-Log Number: T97162
	Project Manager: Irene Rademacher
Contact: Venkat Kalkunte	Project Coordinator: -
Standard: FCC 15.B / 15.407 (New Rules)	Class: N/A

RSS 210 and FCC 15.407 (UNII) Radiated Spurious Emissions

Test Specific Details

Objective: The objective of this test session is to perform final qualification testing of the EUT with respect to the specification listed above.

General Test Configuration

The EUT and all local support equipment were located on the turntable for radiated spurious emissions testing. For radiated emissions testing the measurement antenna was located 3 meters from the EUT, unless otherwise noted.

Ambient Conditions: Temperature: 18-20 °C
Rel. Humidity: 30-40 %

Summary of Results

Run #	Mode	Channel	Target Power Setting	Passing Power Setting	Test Performed	Limit	Result / Margin
1	ac80	42 - 5210MHz	-	14	Restricted Band Edge at 5150 MHz	15.209	53.7 dBµV/m @ 5147.6 MHz (-0.3 dB)
2	ac80	58 - 5290MHz	-	17	Restricted Band Edge at 5350 MHz	15.209	53.1 dBµV/m @ 5373.7 MHz (-0.9 dB)
3	ac80	106 - 5530MHz	-	14	Restricted Band Edge at 5460 MHz	15.209	52.3 dBµV/m @ 5444.9 MHz (-1.7 dB)
					Band Edge 5460 - 5470 MHz	15E	68.0 dBµV/m @ 5469.0 MHz (-0.3 dB)
4	ac80	155 - 5775MHz	-	15	Band Edge 5725MHz	15E	52.0 dBµV/m @ 5724.6 MHz (-2.0 dB)
	ac80				Band Edge 5715MHz	15E	51.4 dBµV/m @ 5714.0 MHz (-2.6 dB)
	ac80	155 - 5775MHz	-	15	Band Edge 5850MHz	15E	52.6 dBµV/m @ 5858.9 MHz (-1.4 dB)
	ac80				Band Edge 5860MHz	15E	51.9 dBµV/m @ 5860.0 MHz (-2.1 dB)

Modifications Made During Testing

No modifications were made to the EUT during testing

Deviations From The Standard

No deviations were made from the requirements of the standard.



EMC Test Data

Client: Vivint Wireless	Job Number: J96161
Model: SR1530 (4x4 5GHz 802.11 AP)	T-Log Number: T97162
	Project Manager: Irene Rademacher
Contact: Venkat Kalkunte	Project Coordinator: -
Standard: FCC 15.B / 15.407 (New Rules)	Class: N/A

Procedure Comments:

Measurements performed in accordance with FCC KDB 789033
 Peak measurements performed with: RBW=1MHz, VBW=3MHz, peak detector, max hold, auto sweep time
 Unless otherwise stated/noted, emission has duty cycle $\geq 98\%$ and was measured using RBW=1MHz, VBW=10Hz, peak detector, linear average mode, auto sweep time, max hold.

Mode	Data Rate	Duty Cycle (x)	Constant DC?	T (ms)	Pwr Cor Factor*	Lin Volt Cor Factor**	Min VBW for FS (Hz)
ac80	MCS8	92.1%	yes	0.58	0.36	0.72	1724

Sample Notes

Sample S/N: Prototype
 Driver: -
 Antenna: 6 dBi

Measurement Specific Notes:

Note 1:	For emissions outside of the restricted bands the limit is -27dBm/MHz eirp (68.3dBuV/m). The measurement method required is a peak measurement (RB=1MHz, VB \geq 3MHz, peak detector). Per KDB 789033 II) G) 2) c), compliance can be demonstrated by meeting the average and peak limits of 15.209, as an alternative.
Note 3:	Emission has duty cycle < 98%, but constant, average measurement performed: RBW=1MHz, VBW=10Hz, peak detector, linear averaging, auto sweep, trace average 100 * 1/DC traces, measurement corrected by Linear Voltage correction factor
Note 6:	Plots of the average and peak bandedge do not account for any duty cycle correction. Refer to the tabluar results for final measurements.

EUT Voltage: POE

Config. Used: 1



EMC Test Data

Client: Vivint Wireless	Job Number: J96161
Model: SR1530 (4x4 5GHz 802.11 AP)	T-Log Number: T97162
	Project Manager: Irene Rademacher
Contact: Venkat Kalkunte	Project Coordinator: -
Standard: FCC 15.B / 15.407 (New Rules)	Class: N/A

Run #1: Radiated Bandedge Measurements, 5150-5250MHz

Date of Test: 2/24/2015 0:00 Config. Used: 1
 Test Engineer: Jack Liu Config Change: -
 Test Location: FT Chamber# 7 EUT Voltage: PoE

Channel: 42 - 5210MHz Power Setting: 14
 Tx Chain: 4Tx Data Rate: MCS 8
 Mode: AC80 Packet Size: 4000

5150 MHz Band Edge Signal Radiated Field Strength

Frequency	Level	Pol	FCC 15.209		Detector	Azimuth	Height	Comments
MHz	dB μ V/m	v/h	Limit	Margin	Pk/QP/Avg	degrees	meters	
Pwr setting 14								
5147.600	53.7	H	54.0	-0.3	AVG	360	1.7	Note 3
5148.880	66.5	H	74.0	-7.5	PK	360	1.7	

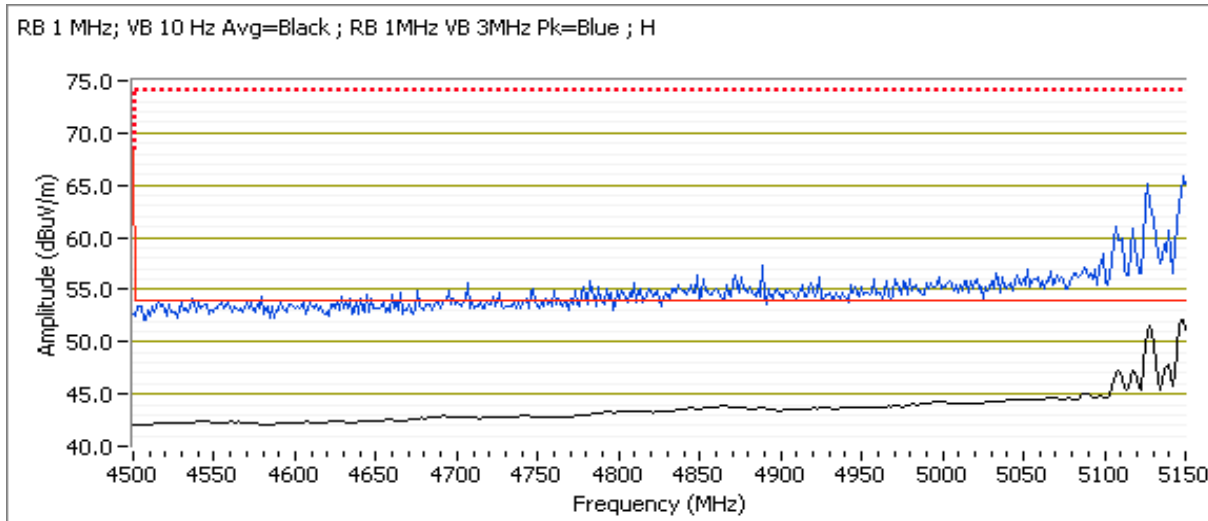



EMC Test Data

Client: Vivint Wireless	Job Number: J96161
Model: SR1530 (4x4 5GHz 802.11 AP)	T-Log Number: T97162
	Project Manager: Irene Rademacher
Contact: Venkat Kalkunte	Project Coordinator: -
Standard: FCC 15.B / 15.407 (New Rules)	Class: N/A

Run #2: Radiated Bandedge Measurements, 5250-5350MHz

Date of Test: 2/24/2015 0:00 Config. Used: 1
 Test Engineer: Jack Liu Config Change: -
 Test Location: FT Chamber# 7 EUT Voltage: PoE

Channel: 58 - 5290MHz Power Setting: 17
 Tx Chain: 4Tx Data Rate: MCS 8
 Mode: AC80 Packet Size: 4000

5350 MHz Band Edge Signal Radiated Field Strength

Frequency	Level	Pol	FCC 15.209		Detector	Azimuth	Height	Comments
MHz	dB μ V/m	v/h	Limit	Margin	Pk/QP/Avg	degrees	meters	
5373.730	53.1	H	54.0	-0.9	AVG	8	1.5	note 3
5373.010	73.1	H	74.0	-0.9	PK	8	1.5	
5363.830	52.5	V	54.0	-1.5	AVG	6	1.5	note 3
5382.220	72.1	V	74.0	-1.9	PK	6	1.5	

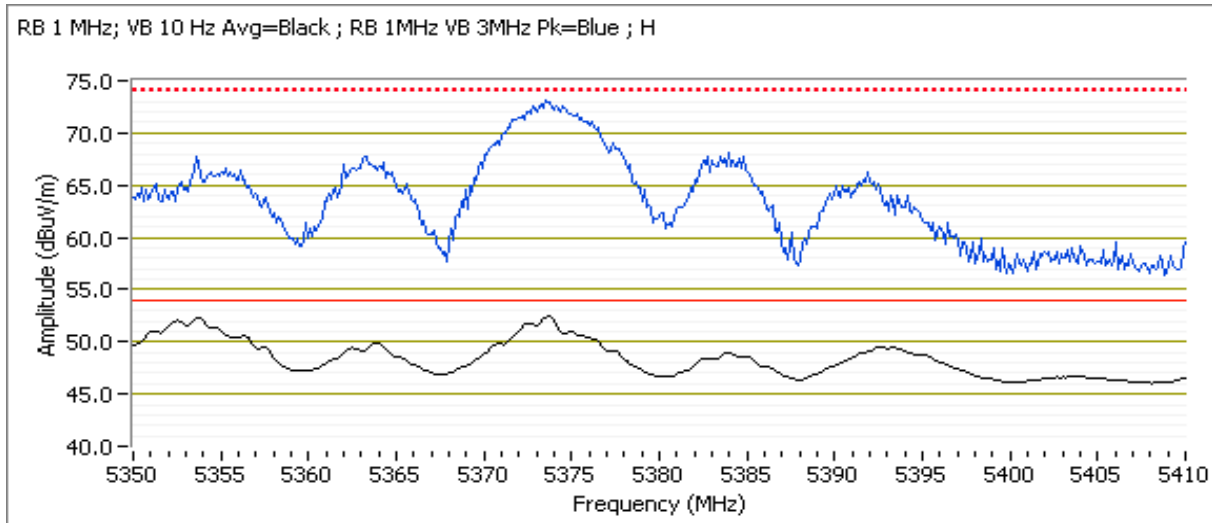



EMC Test Data

Client: Vivint Wireless	Job Number: J96161
Model: SR1530 (4x4 5GHz 802.11 AP)	T-Log Number: T97162
Contact: Venkat Kalkunte	Project Manager: Irene Rademacher
Standard: FCC 15.B / 15.407 (New Rules)	Project Coordinator: -
	Class: N/A

Run #3: Radiated Bandedge Measurements, 5470-5725MHz

Date of Test: 2/24/2015 0:00 Config. Used: 1
 Test Engineer: Jack Liu Config Change: -
 Test Location: FT Chamber# 7 EUT Voltage: PoE

Channel: 106 - 5530 MHz Power Setting: 15
 Tx Chain: 4Tx Data Rate: MCS 8
 Mode: AC80 Packet Size: 4000

5460 MHz Band Edge Signal Radiated Field Strength

Frequency	Level	Pol	FCC 15.209		Detector	Azimuth	Height	Comments
MHz	dB μ V/m	v/h	Limit	Margin	Pk/QP/Avg	degrees	meters	
Pwr setting 15								
5444.850	52.3	H	54.0	-1.7	AVG	0	1.7	note 3
5445.930	65.7	H	74.0	-8.3	PK	0	1.7	
5456.390	52.0	V	54.0	-2.0	AVG	4	1.7	note 3
5436.670	65.2	V	74.0	-8.8	PK	4	1.7	

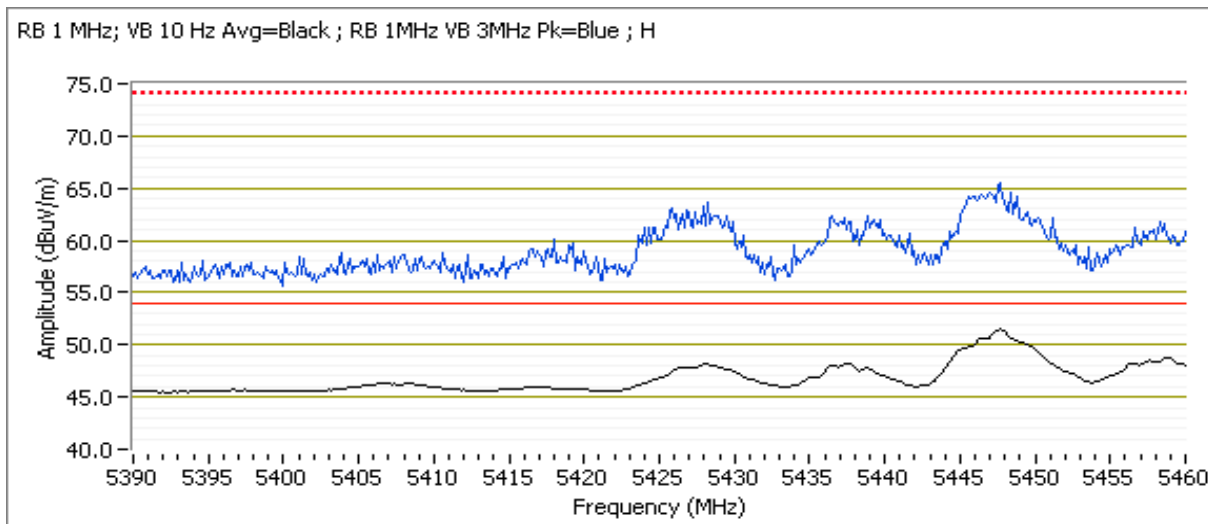



EMC Test Data

Client: Vivint Wireless	Job Number: J96161
Model: SR1530 (4x4 5GHz 802.11 AP)	T-Log Number: T97162
	Project Manager: Irene Rademacher
Contact: Venkat Kalkunte	Project Coordinator: -
Standard: FCC 15.B / 15.407 (New Rules)	Class: N/A

5470 MHz Band Edge Signal Radiated Field Strength

Frequency	Level	Pol	15.E		Detector	Azimuth	Height	Comments
MHz	dB μ V/m	v/h	Limit	Margin	Pk/QP/Avg	degrees	meters	
Pwr setting 14								
5468.960	68.0	H	68.3	-0.3	PK	360	1.7	POS; RB 1 MHz; VB: 3 MHz
5461.580	63.9	V	68.3	-4.4	PK	359	1.6	POS; RB 1 MHz; VB: 3 MHz

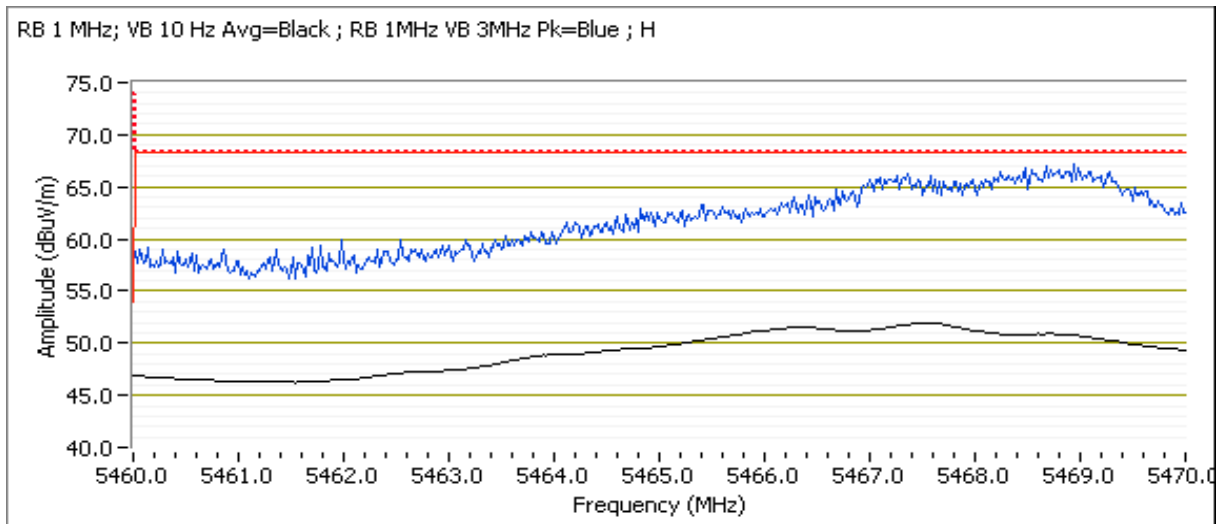



EMC Test Data

Client: Vivint Wireless	Job Number: J96161
Model: SR1530 (4x4 5GHz 802.11 AP)	T-Log Number: T97162
	Project Manager: Irene Rademacher
Contact: Venkat Kalkunte	Project Coordinator: -
Standard: FCC 15.B / 15.407 (New Rules)	Class: N/A

Run #4: Radiated Bandedge Measurements, 5725-5850MHz
 Date of Test: 02/24/15 Test Location: FT Chamber #7
 Test Engineer: Rafael Varelas EUT Voltage: PoE

Channel: 155 - 5775MHz Power Setting: 15
 Tx Chain: 4Tx Data Rate: MCS 8
 Mode: AC80 Packet Size: 4000

5725 MHz Band Edge Signal Radiated Field Strength

Frequency MHz	Level dB μ V/m	Pol v/h	15.E		Detector PK/QP/Avg	Azimuth degrees	Height meters	Comments
			Limit	Margin				
Pwr setting 15								
5715.000	51.1	H	54.0	-2.9	AVG	360	1.9	Note 3, Note 1
5716.760	69.6	H	74.0	-4.4	PK	360	1.9	Note 1
5724.640	52.0	V	54.0	-2.0	AVG	0	1.6	Note 3, Note 1
5724.320	71.4	V	74.0	-2.6	PK	0	1.6	Note 1

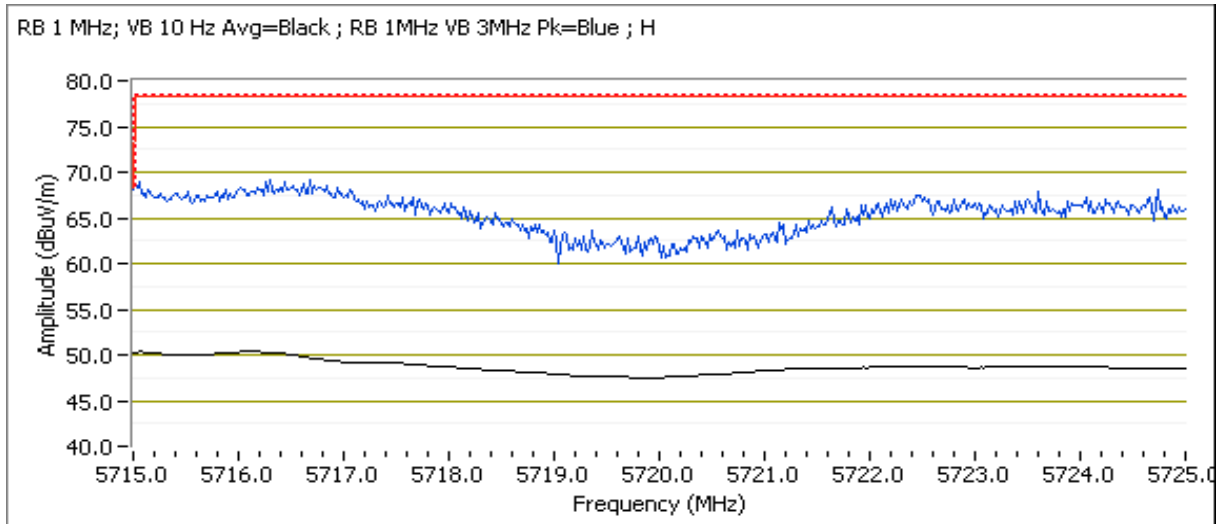



EMC Test Data

Client: Vivint Wireless	Job Number: J96161
Model: SR1530 (4x4 5GHz 802.11 AP)	T-Log Number: T97162
Contact: Venkat Kalkunte	Project Manager: Irene Rademacher
Standard: FCC 15.B / 15.407 (New Rules)	Project Coordinator: -
	Class: N/A

5715 MHz Band Edge Signal Radiated Field Strength

Frequency	Level	Pol	15.E		Detector	Azimuth	Height	Comments
MHz	dB μ V/m	v/h	Limit	Margin	Pk/QP/Avg	degrees	meters	
Pwr setting 15								
5713.980	51.4	H	54.0	-2.6	AVG	360	1.9	Note3,1,POS; RB 1 MHz; VB: 10 Hz
5714.100	70.3	H	74.0	-3.7	PK	360	1.9	Note1,POS; RB 1 MHz; VB: 3 MHz
5707.730	50.0	V	54.0	-4.0	AVG	0	1.6	Note3,1,POS; RB 1 MHz; VB: 10 Hz
5706.940	64.8	V	74.0	-9.2	PK	0	1.6	Note1,POS; RB 1 MHz; VB: 3 MHz

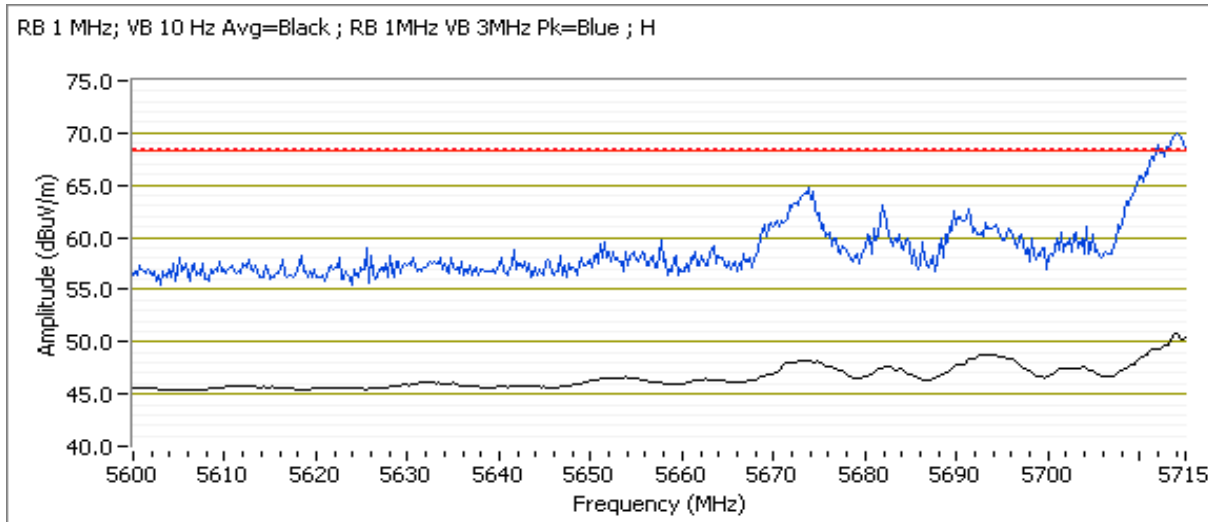



EMC Test Data

Client: Vivint Wireless	Job Number: J96161
Model: SR1530 (4x4 5GHz 802.11 AP)	T-Log Number: T97162
	Project Manager: Irene Rademacher
Contact: Venkat Kalkunte	Project Coordinator: -
Standard: FCC 15.B / 15.407 (New Rules)	Class: N/A

Date of Test: 02/24/15
 Test Engineer: Rafael Varelas

Test Location: FT Chamber #7
 EUT Voltage: PoE

Channel: 155 - 5775MHz
 Tx Chain: 4Tx
 Mode: AC80

Power Setting: 15
 Data Rate: MCS 8
 Packet Size: 4000

5850 MHz Band Edge Signal Radiated Field Strength

Frequency MHz	Level dB μ V/m	Pol v/h	15.E		Detector PK/QP/Avg	Azimuth degrees	Height meters	Comments
			Limit	Margin				
Pwr setting 15								
5858.860	52.6	H	54.0	-1.4	AVG	360	2.0	Note 3, 1
5859.600	71.6	H	74.0	-2.4	PK	360	2.0	Note 1
5851.440	52.3	V	54.0	-1.7	AVG	0	1.9	Note 3, 1
5851.760	69.2	V	74.0	-4.8	PK	0	1.9	Note 1

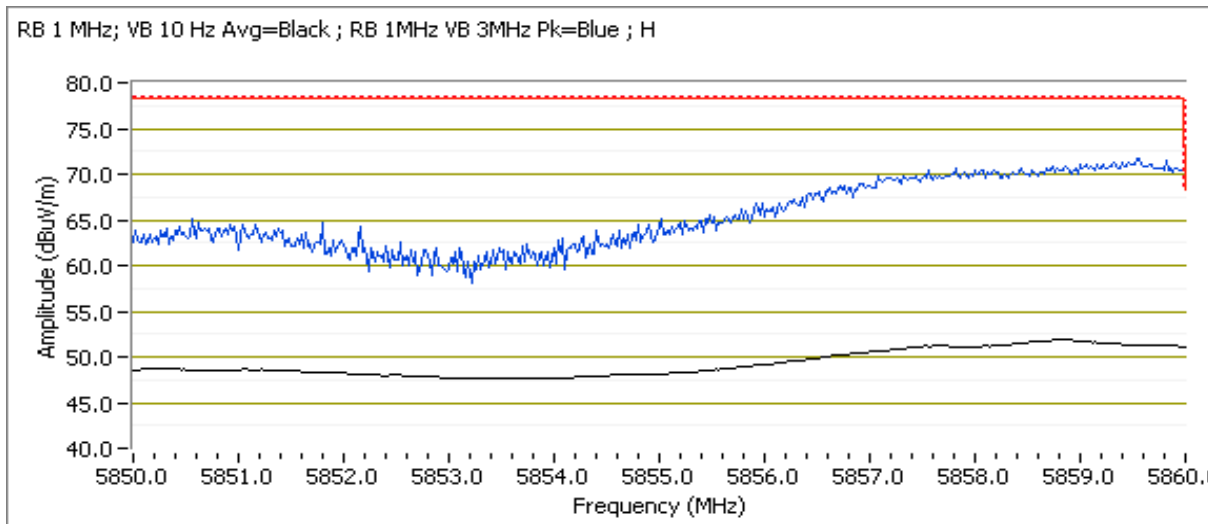



EMC Test Data

Client: Vivint Wireless	Job Number: J96161
Model: SR1530 (4x4 5GHz 802.11 AP)	T-Log Number: T97162
Contact: Venkat Kalkunte	Project Manager: Irene Rademacher
Standard: FCC 15.B / 15.407 (New Rules)	Project Coordinator: -
	Class: N/A

5860 MHz Band Edge Signal Radiated Field Strength

Frequency	Level	Pol	15.E		Detector	Azimuth	Height	Comments
MHz	dB μ V/m	v/h	Limit	Margin	Pk/QP/Avg	degrees	meters	
Pwr setting 15								
5860.000	51.9	H	54.0	-2.1	AVG	360	2.0	Note 3, 1
5860.180	71.3	H	74.0	-2.7	PK	360	2.0	Note 1
5871.300	50.8	V	54.0	-3.2	AVG	0	1.9	Note 3, 1
5870.820	69.4	V	74.0	-4.6	PK	0	1.9	Note 1

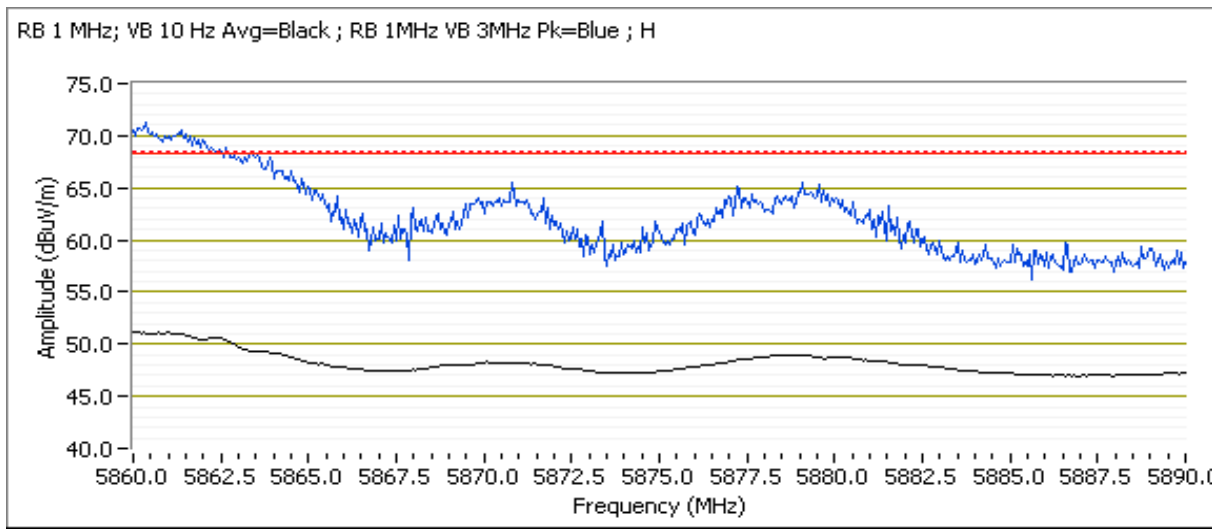



EMC Test Data

Client: Vivint Wireless	Job Number: J96161
Model: SR1530 (4x4 5GHz 802.11 AP)	T-Log Number: T97162
	Project Manager: Irene Rademacher
Contact: Venkat Kalkunte	Project Coordinator: -
Standard: FCC 15.B / 15.407 (New Rules)	Class: N/A

RSS 210 and FCC 15.407 (UNII) Radiated Spurious Emissions

Test Specific Details

Objective: The objective of this test session is to perform final qualification testing of the EUT with respect to the specification listed above.

General Test Configuration

The EUT and all local support equipment were located on the turntable for radiated spurious emissions testing. For radiated emissions testing the measurement antenna was located 3 meters from the EUT, unless otherwise noted.

Ambient Conditions:

Temperature: 21.5 °C
Rel. Humidity: 42 %

Summary of Results

Run #	Mode	Channel	Target Power Setting	Passing Power Setting	Test Performed	Limit	Result / Margin
Scans on "center" channel for all OFDM modes to determine the worst case mode.							
1	n20	40 - 5200MHz	-	21	Radiated Emissions, 1 - 40 GHz	FCC 15.209 / 15 E	50.0 dBµV/m @ 15602.4 MHz (-4.0 dB)
	n40	38 - 5190MHz	-	21			47.2 dBµV/m @ 15575.6 MHz (-6.8 dB)
	ac80	42 - 5210MHz	-	21			50.9 dBµV/m @ 5045.1 MHz (-3.1 dB)
Measurements on low and high channels in worst-case OFDM mode.							
2	n20	36 - 5180MHz	-	21	Radiated Emissions, 1 - 40 GHz	FCC 15.209 / 15 E	47.1 dBµV/m @ 5046.5 MHz (-6.9 dB)
	n20	48 - 5240MHz	-	21	Radiated Emissions, 1 - 40 GHz	FCC 15.209 / 15 E	43.4 dBµV/m @ 1500.0 MHz (-10.6 dB)
Scans on "center" channel for all OFDM modes to determine the worst case mode.							
3	n20	60 - 5300MHz	-	21	Radiated Emissions, 1 - 40 GHz	FCC 15.209 / 15 E	48.7 dBµV/m @ 21200.3 MHz (-5.3 dB)
	n40	54 - 5270MHz	-	21			47.1 dBµV/m @ 15820.8 MHz (-6.9 dB)
	ac80	58 - 5290MHz	-	21			49.4 dBµV/m @ 21160.2 MHz (-4.6 dB)



EMC Test Data

Client: Vivint Wireless	Job Number: J96161
Model: SR1530 (4x4 5GHz 802.11 AP)	T-Log Number: T97162
	Project Manager: Irene Rademacher
Contact: Venkat Kalkunte	Project Coordinator: -
Standard: FCC 15.B / 15.407 (New Rules)	Class: N/A

Run #	Mode	Channel	Target Power Setting	Passing Power Setting	Test Performed	Limit	Result / Margin
-------	------	---------	----------------------	-----------------------	----------------	-------	-----------------

Measurements on low and high channels in worst-case OFDM mode.

4	ac80	No testing performed as worse case was ac80, and there is only one available ac80 channel within the band					
---	------	---	--	--	--	--	--

Scans on "center" channel for all OFDM modes to determine the worst case mode.

5	n20	116 - 5580MHz	-	21	Radiated Emissions, 1 - 40 GHz	FCC 15.209 / 15 E	51.7 dBµV/m @ 22320.3 MHz (-2.3 dB)
	n40	110 - 5550MHz	-	21			50.4 dBµV/m @ 22200.3 MHz (-3.6 dB)
	ac80	122 - 5610MHz	-	21			52.5 dBµV/m @ 22440.2 MHz (-1.5 dB)

Measurements on low and high channels in worst-case OFDM mode.

6	ac80	No testing performed as worse case was ac80, and there is only one available ac80 channel within the band					
---	------	---	--	--	--	--	--

Scans on "center" channel for all OFDM modes to determine the worst case mode.

7	n20	157 - 5785MHz	-	21	Radiated Emissions, 1 - 40 GHz	FCC 15.209 / 15 E	64.7 dBµV/m @ 17347.1 MHz (-3.6 dB)
	n40	159 - 5795MHz	-	21			49.5 dBµV/m @ 11599.4 MHz (-4.5 dB)
	ac80	155 - 5775MHz	-	21			64.7 dBµV/m @ 17365.5 MHz (-3.6 dB)

Measurements on low and high channels in worst-case OFDM mode.

8	n20	149 - 5745MHz	-	21	Radiated Emissions, 1 - 40 GHz	FCC 15.209 / 15 E	51.5 dBµV/m @ 22980.4 MHz (-2.5 dB)
		165 - 5825MHz	-	21			48.6 dBµV/m @ 11648.3 MHz (-5.4 dB)

--	--	--	--	--	--	--	--



EMC Test Data

Client: Vivint Wireless	Job Number: J96161
Model: SR1530 (4x4 5GHz 802.11 AP)	T-Log Number: T97162
	Project Manager: Irene Rademacher
Contact: Venkat Kalkunte	Project Coordinator: -
Standard: FCC 15.B / 15.407 (New Rules)	Class: N/A

Modifications Made During Testing

No modifications were made to the EUT during testing

Deviations From The Standard

No deviations were made from the requirements of the standard.

Procedure Comments:

Measurements performed in accordance with FCC KDB 789033

Peak measurements performed with: RBW=1MHz, VBW=3MHz, peak detector, max hold, auto sweep time

Unless otherwise stated/noted, emission has duty cycle $\geq 98\%$ and was measured using RBW=1MHz, VBW=10Hz, peak detector, linear average mode, auto sweep time, max hold.

Preliminary testing showed no radio related emissions below 1GHz

Mode	Data Rate	Duty Cycle (x)	Constant DC?	T (ms)	Pwr Cor Factor*	Lin Volt Cor Factor**	Min VBW for FS (Hz)
n20	MCS8	97.0%	yes	2.54	0.13	0.26	394
n40	13.5	94.3%	yes	1.27	0.26	0.51	787
ac80	MCS8	92.1%	yes	0.58	0.36	0.72	1724

Sample Notes

Sample S/N: Prototype

Driver: -

Antenna: 6 dBi

Measurement Specific Notes:

Note 1:	For emissions outside of the restricted bands the limit is -27dBm/MHz eirp (68.3dBuV/m). The measurement method required is a peak measurement (RB=1MHz, VB \geq 3MHz, peak detector). Per KDB 789033 II) G) 2) c), compliance can be demonstrated by meeting the average and peak limits of 15.209, as an alternative.
Note 3:	Emission has duty cycle < 98%, but constant, average measurement performed: RBW=1MHz, VBW=10Hz, peak detector, linear averaging, auto sweep, trace average 100 * 1/DC traces, measurement corrected by Linear Voltage correction factor
Note 6:	Plots of the average and peak bandedge do not account for any duty cycle correction. Refer to the tabluar results for final measurements.



EMC Test Data

Client: Vivint Wireless	Job Number: J96161
Model: SR1530 (4x4 5GHz 802.11 AP)	T-Log Number: T97162
	Project Manager: Irene Rademacher
Contact: Venkat Kalkunte	Project Coordinator: -
Standard: FCC 15.B / 15.407 (New Rules)	Class: N/A

Run #1, Radiated Spurious Emissions, 1,000 - 40,000 MHz. Operation in the 5150-5250 MHz Band

Date of Test: 2/24/15, 2/25/15, 2/26/15 Config. Used: 1
 Test Engineer: Rafael Varelas / Jack Liu Config Change: None
 Test Location: FT Chamber #7 EUT Voltage: PoE

Run #1a: Center Channel

Channel: 40 Mode: 11n20
 Tx Chain: 4x4 Data Rate: MCS8

Frequency MHz	Level dBμV/m	Pol v/h	15.209 / 15E		Detector Pk/QP/Avg	Azimuth degrees	Height meters	Comments
			Limit	Margin				
15602.400	50.0	V	54.0	-4.0	AVG	131	1.7	Note3; RB 1 MHz;VB 10 Hz;Peak
15600.930	61.2	V	74.0	-12.8	PK	131	1.7	RB 1 MHz;VB 3 MHz;Peak
5039.950	43.2	V	54.0	-10.8	AVG	360	1.6	Note 3,RB 1 MHz;VB 10 Hz;Peak
5035.970	53.5	V	74.0	-20.5	PK	360	1.6	RB 1 MHz;VB 3 MHz;Peak
5436.480	44.1	H	54.0	-9.9	AVG	359	1.7	Note 3,RB 1 MHz;VB 10 Hz;Peak
5433.580	53.8	H	74.0	-20.2	PK	359	1.7	RB 1 MHz;VB 3 MHz;Peak
10400.620	61.3	V	68.3	-7.0	PK	306	2.1	RB 1 MHz;VB 3 MHz;Peak
1500.010	46.8	V	54.0	-7.2	AVG	204	2.4	RB 1 MHz;VB 10 Hz;Peak
1500.050	50.8	V	74.0	-23.2	PK	204	2.4	RB 1 MHz;VB 3 MHz;Peak
1125.020	41.3	H	54.0	-12.7	AVG	207	1.9	RB 1 MHz;VB 10 Hz;Peak
1125.060	45.5	H	74.0	-28.5	PK	207	1.9	RB 1 MHz;VB 3 MHz;Peak
6919.040	56.4	V	68.3	-11.9	PK	16	1.9	RB 1 MHz;VB 3 MHz;Peak
20809.400	37.7	H	54.0	-16.3	AVG	176	2.2	RB 1 MHz;VB 10 Hz;Peak
20810.970	49.8	H	74.0	-24.2	PK	176	2.2	RB 1 MHz;VB 3 MHz;Peak

Note: Preliminary Scans made between 18 - 40 GHz with the measurement antenna moved around the card and its antennas 20-50cm from the device. Plot not included.

Client: Vivint Wireless	Job Number: J96161
Model: SR1530 (4x4 5GHz 802.11 AP)	T-Log Number: T97162
	Project Manager: Irene Rademacher
Contact: Venkat Kalkunte	Project Coordinator: -
Standard: FCC 15.B / 15.407 (New Rules)	Class: N/A

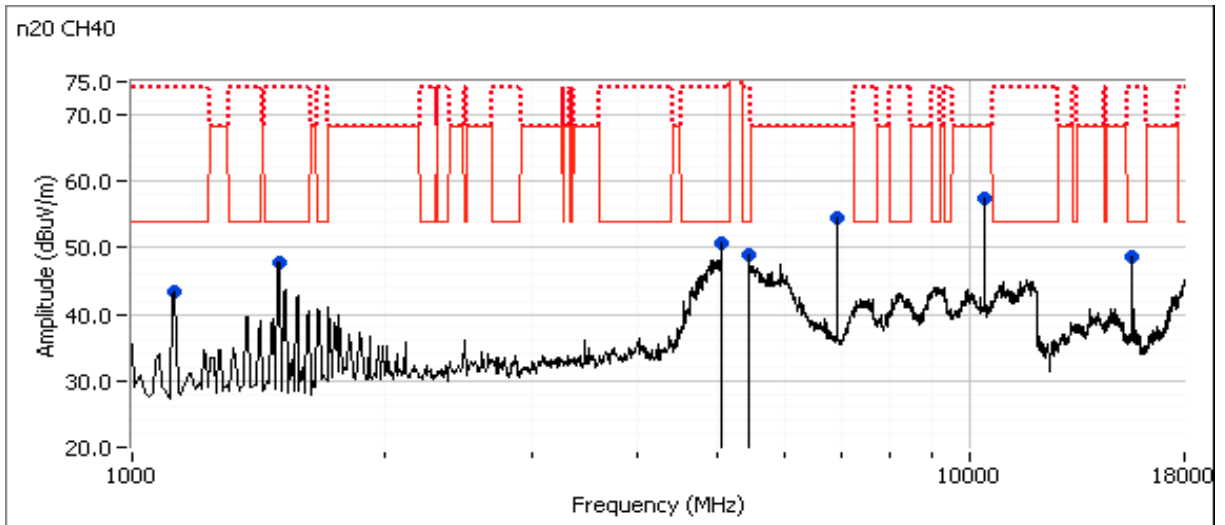



EMC Test Data

Client: Vivint Wireless	Job Number: J96161
Model: SR1530 (4x4 5GHz 802.11 AP)	T-Log Number: T97162
	Project Manager: Irene Rademacher
Contact: Venkat Kalkunte	Project Coordinator: -
Standard: FCC 15.B / 15.407 (New Rules)	Class: N/A

Run #1b: Center Channel

Channel: 38 Mode: 11n40
 Tx Chain: 4x4 Data Rate: MCS8

Frequency MHz	Level dB μ V/m	Pol v/h	15.209 / 15E		Detector Pk/QP/Avg	Azimuth degrees	Height meters	Comments
			Limit	Margin				
15575.600	47.2	H	54.0	-6.8	AVG	134	1.5	Note 3, RB 1 MHz; VB 10 Hz; Peak
15567.870	57.3	H	74.0	-16.7	PK	134	1.5	RB 1 MHz; VB 3 MHz; Peak
1125.040	41.4	H	54.0	-12.6	AVG	208	1.8	RB 1 MHz; VB 10 Hz; Peak
1124.970	45.6	H	74.0	-28.4	PK	208	1.8	RB 1 MHz; VB 3 MHz; Peak
1500.020	46.5	V	54.0	-7.5	AVG	202	2.4	RB 1 MHz; VB 10 Hz; Peak
1499.940	50.4	V	74.0	-23.6	PK	202	2.4	RB 1 MHz; VB 3 MHz; Peak
5459.770	42.6	H	54.0	-11.4	AVG	354	1.8	Note 3, RB 1 MHz; VB 10 Hz; Peak
5459.100	52.8	H	74.0	-21.2	PK	354	1.8	RB 1 MHz; VB 3 MHz; Peak
5014.210	45.3	H	54.0	-8.7	AVG	357	1.7	Note 3, RB 1 MHz; VB 10 Hz; Peak
5017.080	55.2	H	74.0	-18.8	PK	357	1.7	RB 1 MHz; VB 3 MHz; Peak
10384.250	57.6	V	68.3	-10.7	PK	164	1.0	RB 1 MHz; VB 3 MHz; Peak
6920.040	56.4	V	68.3	-11.9	PK	16	1.9	RB 1 MHz; VB 3 MHz; Peak
20766.760	37.8	H	54.0	-16.2	AVG	209	2.2	RB 1 MHz; VB 10 Hz; Peak
20767.560	48.5	H	74.0	-25.5	PK	209	2.2	RB 1 MHz; VB 3 MHz; Peak

Note: Preliminary Scans made between 18 - 40 GHz with the measurement antenna moved around the card and its antennas 20-50cm from the device. Plot not included.

Client: Vivint Wireless	Job Number: J96161
Model: SR1530 (4x4 5GHz 802.11 AP)	T-Log Number: T97162
	Project Manager: Irene Rademacher
Contact: Venkat Kalkunte	Project Coordinator: -
Standard: FCC 15.B / 15.407 (New Rules)	Class: N/A

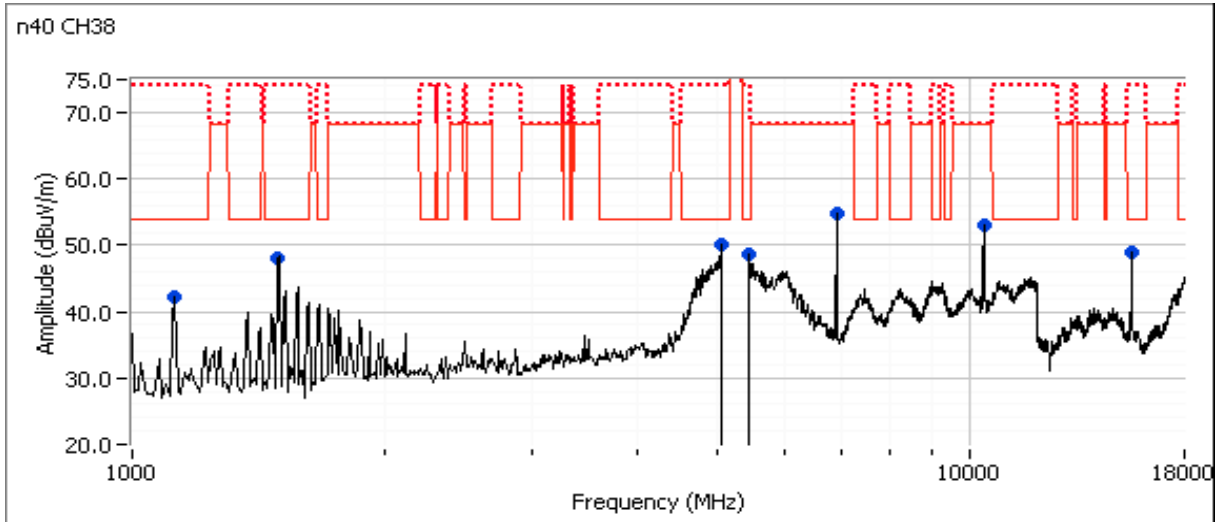



EMC Test Data

Client: Vivint Wireless	Job Number: J96161
Model: SR1530 (4x4 5GHz 802.11 AP)	T-Log Number: T97162
	Project Manager: Irene Rademacher
Contact: Venkat Kalkunte	Project Coordinator: -
Standard: FCC 15.B / 15.407 (New Rules)	Class: N/A

Run #1c: Center Channel

Channel: 42 Mode: ac80
 Tx Chain: 4x4 Data Rate: MCS8

Frequency MHz	Level dB μ V/m	Pol v/h	15.209 / 15E		Detector Pk/QP/Avg	Azimuth degrees	Height meters	Comments
			Limit	Margin				
5045.100	50.9	H	54.0	-3.1	AVG	0	1.6	Note 3, RB 1 MHz; VB 10 Hz; Peak
5045.700	66.0	H	74.0	-8.0	PK	0	1.6	RB 1 MHz; VB 3 MHz; Peak
6946.650	55.7	V	68.3	-12.6	PK	10	2.0	RB 1 MHz; VB 3 MHz; Peak
10421.520	56.1	V	68.3	-12.2	PK	247	1.2	RB 1 MHz; VB 3 MHz; Peak
1500.050	47.3	V	54.0	-6.7	AVG	204	2.3	RB 1 MHz; VB 10 Hz; Peak
1499.950	51.2	V	74.0	-22.8	PK	204	2.3	RB 1 MHz; VB 3 MHz; Peak
1125.020	41.9	H	54.0	-12.1	AVG	213	1.9	RB 1 MHz; VB 10 Hz; Peak
1124.970	46.2	H	74.0	-27.8	PK	213	1.9	RB 1 MHz; VB 3 MHz; Peak
5000.440	42.8	H	54.0	-11.2	AVG	350	1.8	Note 3, RB 1 MHz; VB 10 Hz; Peak
4999.800	59.3	H	74.0	-14.7	PK	350	1.8	RB 1 MHz; VB 3 MHz; Peak
5449.630	44.4	V	54.0	-9.6	AVG	360	1.6	Note 3, RB 1 MHz; VB 10 Hz; Peak
5449.060	55.6	V	74.0	-18.4	PK	360	1.6	RB 1 MHz; VB 3 MHz; Peak
15632.750	47.8	H	54.0	-6.2	AVG	134	1.5	Note 3, RB 1 MHz; VB 10 Hz; Peak
15674.620	58.3	H	74.0	-15.7	PK	134	1.5	RB 1 MHz; VB 3 MHz; Peak
20852.920	37.8	H	54.0	-16.2	AVG	104	2.2	RB 1 MHz; VB 10 Hz; Peak
20853.030	49.2	H	74.0	-24.8	PK	104	2.2	RB 1 MHz; VB 3 MHz; Peak

Note: Preliminary Scans made between 18 - 40 GHz with the measurement antenna moved around the card and its antennas 20-50cm from the device. Plot not included.

Client: Vivint Wireless	Job Number: J96161
Model: SR1530 (4x4 5GHz 802.11 AP)	T-Log Number: T97162
	Project Manager: Irene Rademacher
Contact: Venkat Kalkunte	Project Coordinator: -
Standard: FCC 15.B / 15.407 (New Rules)	Class: N/A

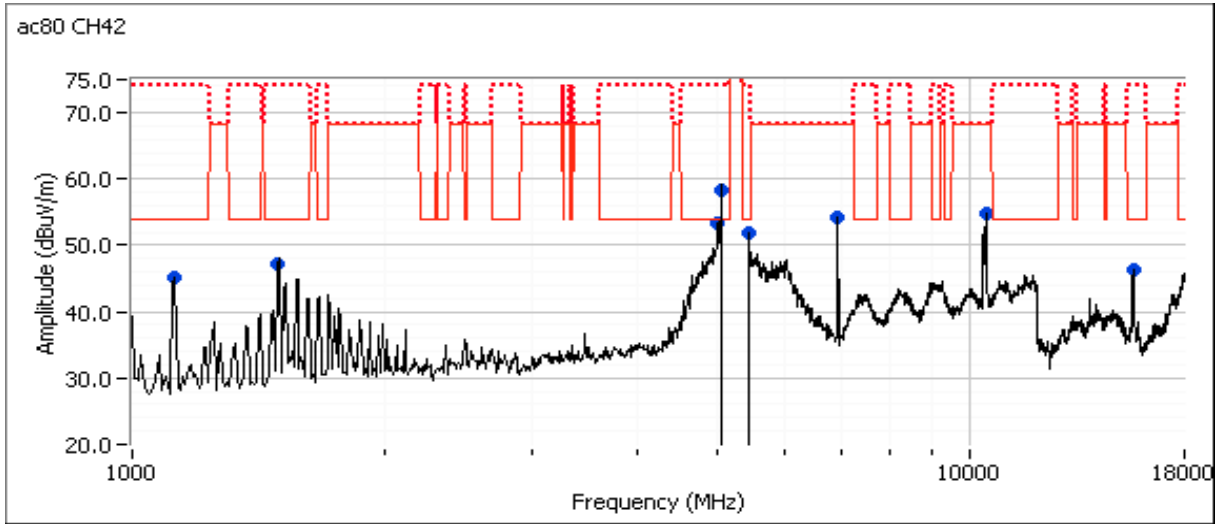



EMC Test Data

Client: Vivint Wireless	Job Number: J96161
Model: SR1530 (4x4 5GHz 802.11 AP)	T-Log Number: T97162
	Project Manager: Irene Rademacher
Contact: Venkat Kalkunte	Project Coordinator: -
Standard: FCC 15.B / 15.407 (New Rules)	Class: N/A

Run #2: Radiated Spurious Emissions, 1,000 - 40000 MHz. Operating Mode: Worse case from Run #1

Date of Test: 2/26/2015 0:00 Config. Used: 1
 Test Engineer: Joseph Cadigal Config Change: none
 Test Location: FT Chamber#7 EUT Voltage: PoE

Run #2a: Low Channel

Channel: 36 Mode: 11n20
 Tx Chain: 4x4 Data Rate: MCS8

Frequency	Level	Pol	15.209 / 15.247		Detector	Azimuth	Height	Comments
MHz	dB μ V/m	v/h	Limit	Margin	Pk/QP/Avg	degrees	meters	
5046.500	47.1	V	54.0	-6.9	AVG	18	1.6	Note 3, RB 1 MHz; VB 10 Hz; Peak
5047.120	57.9	V	74.0	-16.1	PK	18	1.6	RB 1 MHz; VB 3 MHz; Peak
20720.360	44.4	H	54.0	-9.6	AVG	98	2.2	RB 1 MHz; VB 10 Hz; Peak
20720.360	51.9	H	74.0	-22.1	PK	98	2.2	RB 1 MHz; VB 3 MHz; Peak
6906.750	58.9	H	68.3	-9.4	PK	18	1.9	RB 1 MHz; VB 3 MHz; Peak
5425.240	46.6	V	54.0	-7.4	AVG	18	1.6	Note 3, RB 1 MHz; VB 10 Hz; Peak
5424.760	58.1	V	74.0	-15.9	PK	18	1.6	RB 1 MHz; VB 3 MHz; Peak
10367.590	58.0	V	68.3	-10.3	PK	118	2.5	RB 1 MHz; VB 3 MHz; Peak
1125.020	41.9	V	54.0	-12.1	AVG	210	2.5	RB 1 MHz; VB 10 Hz; Peak
1125.070	48.1	V	74.0	-25.9	PK	210	2.5	RB 1 MHz; VB 3 MHz; Peak
1499.990	44.1	H	54.0	-9.9	AVG	224	2.5	RB 1 MHz; VB 10 Hz; Peak
1499.970	50.2	H	74.0	-23.8	PK	224	2.5	RB 1 MHz; VB 3 MHz; Peak

Note: Preliminary Scans made between 18 - 40 GHz with the measurement antenna moved around the card and its antennas 20-50cm from the device. Plot not included.

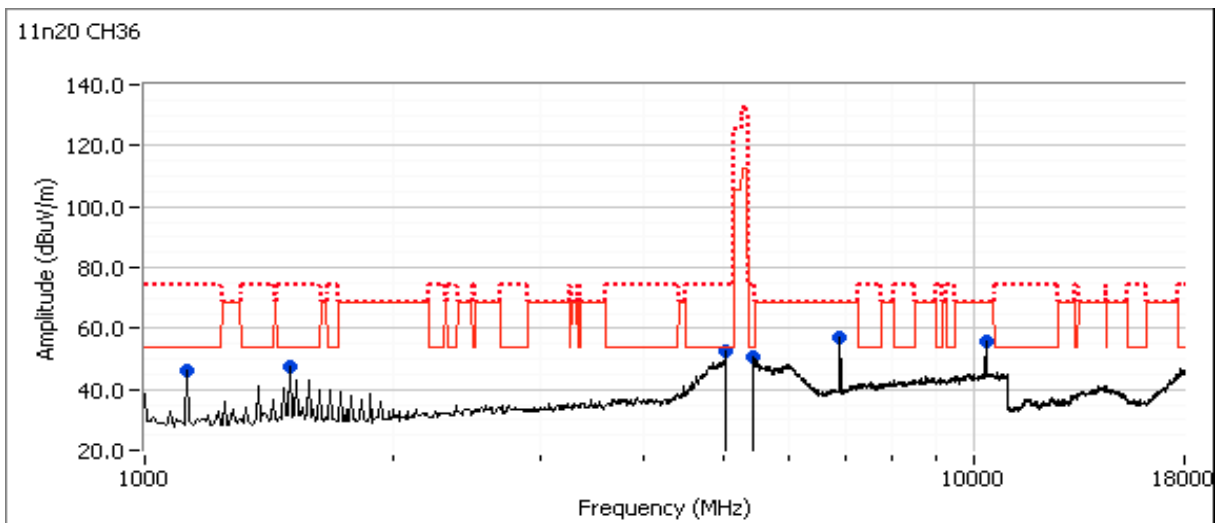

Client: Vivint Wireless	Job Number: J96161
Model: SR1530 (4x4 5GHz 802.11 AP)	T-Log Number: T97162
	Project Manager: Irene Rademacher
Contact: Venkat Kalkunte	Project Coordinator: -
Standard: FCC 15.B / 15.407 (New Rules)	Class: N/A

Run #2b: High Channel

Channel: 48 Mode: 11n20
 Tx Chain: 4x4 Data Rate: MCS8

Frequency	Level	Pol	15.209 / 15.247		Detector	Azimuth	Height	Comments
MHz	dB μ V/m	v/h	Limit	Margin	PK/QP/Avg	degrees	meters	
1500.010	43.4	H	54.0	-10.6	AVG	210	2.5	RB 1 MHz;VB 10 Hz;Peak
1500.130	49.1	H	74.0	-24.9	PK	210	2.5	RB 1 MHz;VB 3 MHz;Peak
20982.720	37.9	H	54.0	-16.1	AVG	97	2.2	RB 1 MHz;VB 10 Hz;Peak
20981.010	48.7	H	74.0	-25.3	PK	97	2.2	RB 1 MHz;VB 3 MHz;Peak
5040.030	39.9	H	54.0	-14.1	AVG	8	1.9	Note 3, RB 1 MHz;VB 10 Hz;Peak
5042.220	49.5	H	74.0	-24.5	PK	8	1.9	RB 1 MHz;VB 3 MHz;Peak
6986.830	56.9	H	68.3	-11.4	PK	29	1.9	RB 1 MHz;VB 3 MHz;Peak
1125.040	42.4	V	54.0	-11.6	AVG	215	2.5	RB 1 MHz;VB 10 Hz;Peak
1124.980	48.5	V	74.0	-25.5	PK	215	2.5	RB 1 MHz;VB 3 MHz;Peak
10477.710	57.9	V	68.3	-10.4	PK	240	2.5	RB 1 MHz;VB 3 MHz;Peak
5434.330	39.3	V	54.0	-14.7	AVG	352	1.3	Note 3, RB 1 MHz;VB 10 Hz;Peak
5434.210	49.8	V	74.0	-24.2	PK	352	1.3	RB 1 MHz;VB 3 MHz;Peak

Note: Preliminary Scans made between 18 - 40 GHz with the measurement antenna moved around the card and its antennas 20-50cm from the device. Plot not included.

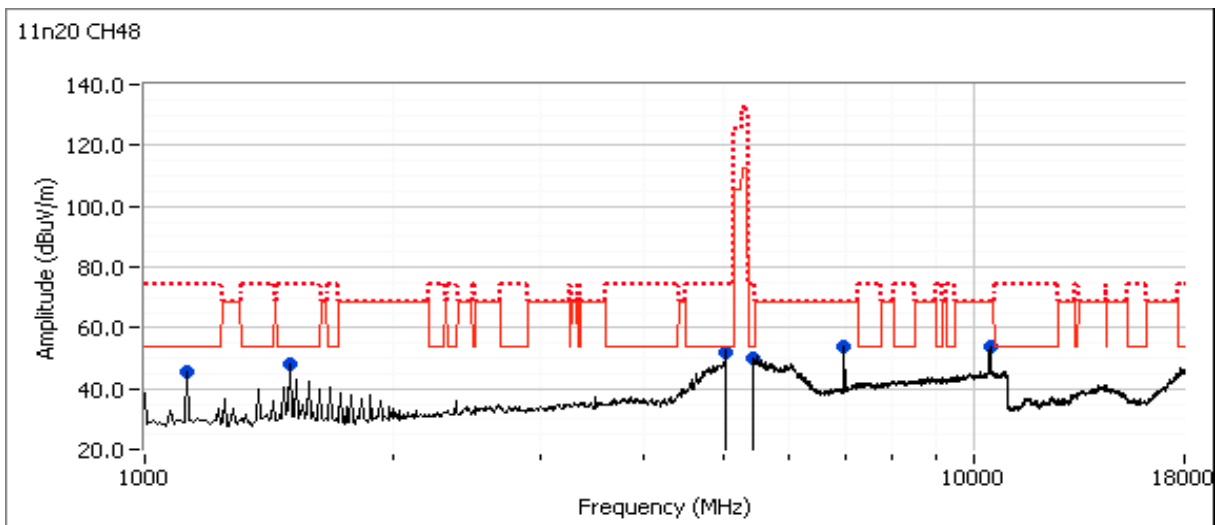



EMC Test Data

Client: Vivint Wireless	Job Number: J96161
Model: SR1530 (4x4 5GHz 802.11 AP)	T-Log Number: T97162
	Project Manager: Irene Rademacher
Contact: Venkat Kalkunte	Project Coordinator: -
Standard: FCC 15.B / 15.407 (New Rules)	Class: N/A

Run #3, Radiated Spurious Emissions, 1,000 - 40,000 MHz. Operation in the 5250-5350 MHz Band

Date of Test: 2/24/15, 2/25/15
 Test Engineer: Rafael Varelas / Jack Liu
 Test Location: FT Chamber #7
 Config. Used: 1
 Config Change: None
 EUT Voltage: PoE

Run #3a: Center Channel

Channel: 60 Mode: n20
 Tx Chain: 4x4 Data Rate: MCS8

Frequency MHz	Level dB μ V/m	Pol v/h	15.209 / 15E		Detector Pk/QP/Avg	Azimuth degrees	Height meters	Comments
			Limit	Margin				
10600.790	47.3	V	54.0	-6.7	AVG	229	2.2	Note 3, RB 1 MHz; VB 10 Hz; Peak
10602.240	58.2	V	74.0	-15.8	PK	229	2.2	RB 1 MHz; VB 3 MHz; Peak
1500.030	47.2	V	54.0	-6.8	AVG	208	2.4	RB 1 MHz; VB 10 Hz; Peak
1500.060	51.3	V	74.0	-22.7	PK	208	2.4	RB 1 MHz; VB 3 MHz; Peak
1125.020	41.5	H	54.0	-12.5	AVG	205	2.0	RB 1 MHz; VB 10 Hz; Peak
1125.030	45.7	H	74.0	-28.3	PK	205	2.0	RB 1 MHz; VB 3 MHz; Peak
7066.810	52.9	V	68.3	-15.4	PK	11	2.0	RB 1 MHz; VB 3 MHz; Peak
5031.240	44.9	H	54.0	-9.1	AVG	0	2.2	Note 3, RB 1 MHz; VB 10 Hz; Peak
5042.900	55.8	H	74.0	-18.2	PK	0	2.2	RB 1 MHz; VB 3 MHz; Peak
5459.940	45.7	V	54.0	-8.3	AVG	4	2.0	Note 3, RB 1 MHz; VB 10 Hz; Peak
5453.470	54.7	V	74.0	-19.3	PK	4	2.0	RB 1 MHz; VB 3 MHz; Peak
15899.400	46.6	V	54.0	-7.4	AVG	174	1.5	Note 3, RB 1 MHz; VB 10 Hz; Peak
15889.130	59.5	V	74.0	-14.5	PK	174	1.5	RB 1 MHz; VB 3 MHz; Peak
21200.300	48.7	H	54.0	-5.3	AVG	124	1.67	Note 3
21200.470	53.7	H	74.0	-20.3	PK	124	1.67	

Note 1: For emissions in restricted bands, the limit of 15.209 was used which requires average and peak measurements.

Client: Vivint Wireless	Job Number: J96161
Model: SR1530 (4x4 5GHz 802.11 AP)	T-Log Number: T97162
	Project Manager: Irene Rademacher
Contact: Venkat Kalkunte	Project Coordinator: -
Standard: FCC 15.B / 15.407 (New Rules)	Class: N/A

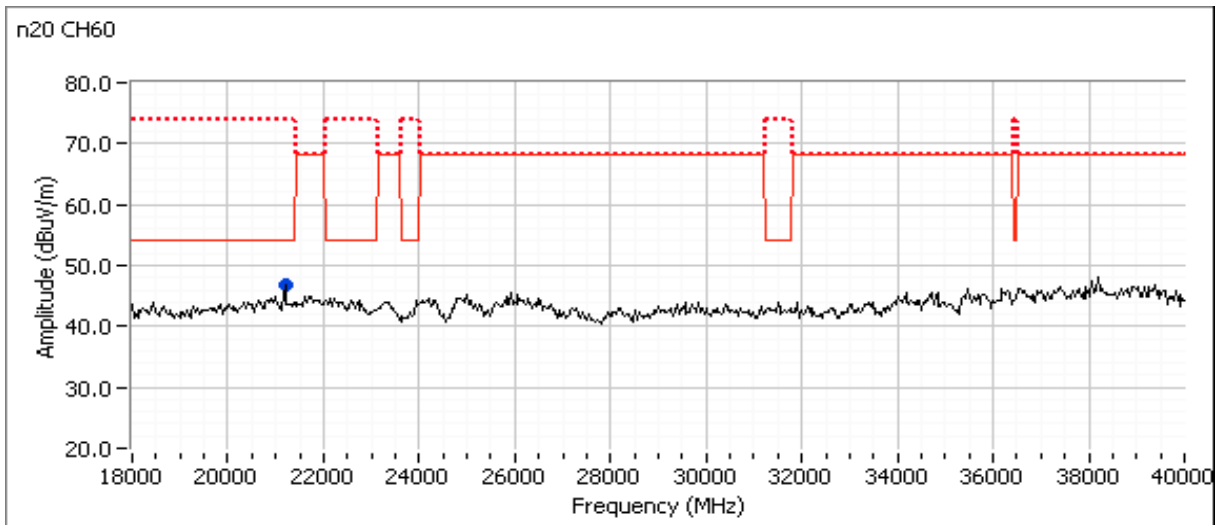
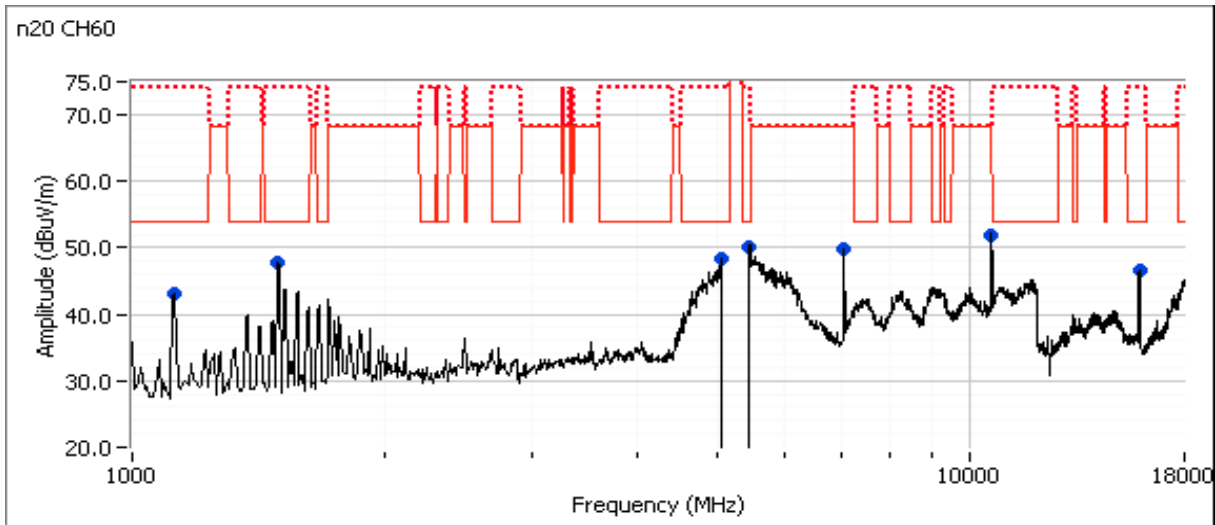



EMC Test Data

Client: Vivint Wireless	Job Number: J96161
Model: SR1530 (4x4 5GHz 802.11 AP)	T-Log Number: T97162
	Project Manager: Irene Rademacher
Contact: Venkat Kalkunte	Project Coordinator: -
Standard: FCC 15.B / 15.407 (New Rules)	Class: N/A

Run #3b: Center Channel

Channel: 54 Mode: 11n40
 Tx Chain: 4x4 Data Rate: MCS8

Frequency MHz	Level dB μ V/m	Pol v/h	15.209 / 15E		Detector Pk/QP/Avg	Azimuth degrees	Height meters	Comments
			Limit	Margin				
7026.710	53.0	V	68.3	-15.3	PK	18	1.9	RB 1 MHz;VB 3 MHz;Peak
10541.520	52.0	H	68.3	-16.3	PK	122	1.9	RB 1 MHz;VB 3 MHz;Peak
1124.990	41.9	H	54.0	-12.1	AVG	213	2.1	RB 1 MHz;VB 10 Hz;Peak
1124.960	45.8	H	74.0	-28.2	PK	213	2.1	RB 1 MHz;VB 3 MHz;Peak
1500.020	46.9	V	54.0	-7.1	AVG	206	2.4	RB 1 MHz;VB 10 Hz;Peak
1500.010	50.9	V	74.0	-23.1	PK	206	2.4	RB 1 MHz;VB 3 MHz;Peak
5453.130	46.8	V	54.0	-7.2	AVG	360	1.6	Note 3, RB 1 MHz;VB 10 Hz;Peak
5450.800	57.8	V	74.0	-16.2	PK	360	1.6	RB 1 MHz;VB 3 MHz;Peak
5030.490	45.9	H	54.0	-8.1	AVG	360	1.8	Note 3, RB 1 MHz;VB 10 Hz;Peak
5031.290	55.9	H	74.0	-18.1	PK	360	1.8	RB 1 MHz;VB 3 MHz;Peak
15820.800	47.1	H	54.0	-6.9	AVG	201	1.4	Note 3, RB 1 MHz;VB 10 Hz;Peak
15795.450	57.2	H	74.0	-16.8	PK	201	1.4	RB 1 MHz;VB 3 MHz;Peak

Note 1: For emissions in restricted bands, the limit of 15.209 was used which requires average and peak measurements.

Client: Vivint Wireless	Job Number: J96161
Model: SR1530 (4x4 5GHz 802.11 AP)	T-Log Number: T97162
Contact: Venkat Kalkunte	Project Manager: Irene Rademacher
Standard: FCC 15.B / 15.407 (New Rules)	Project Coordinator: -
	Class: N/A

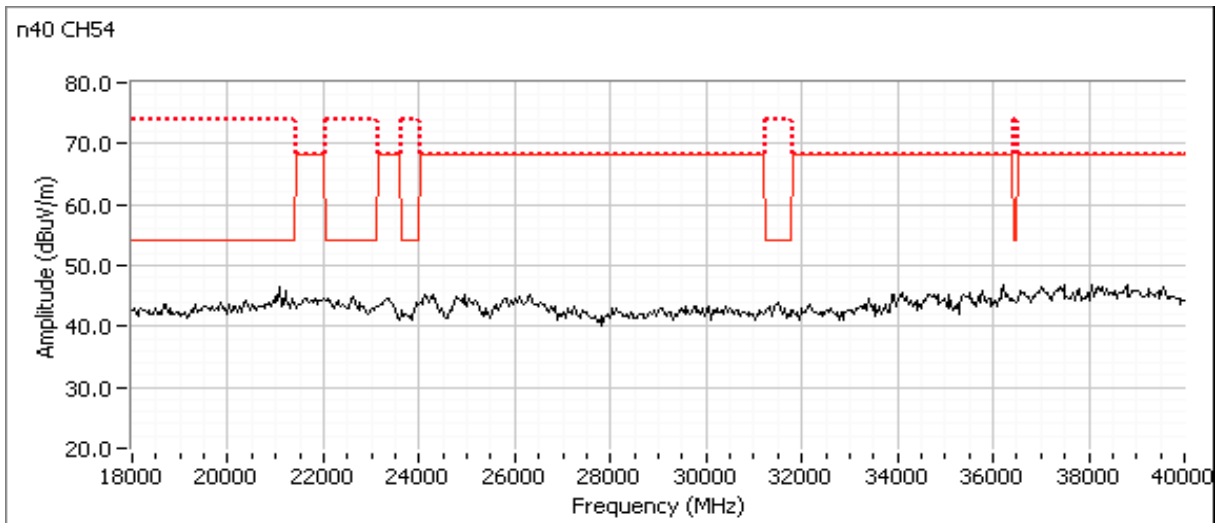
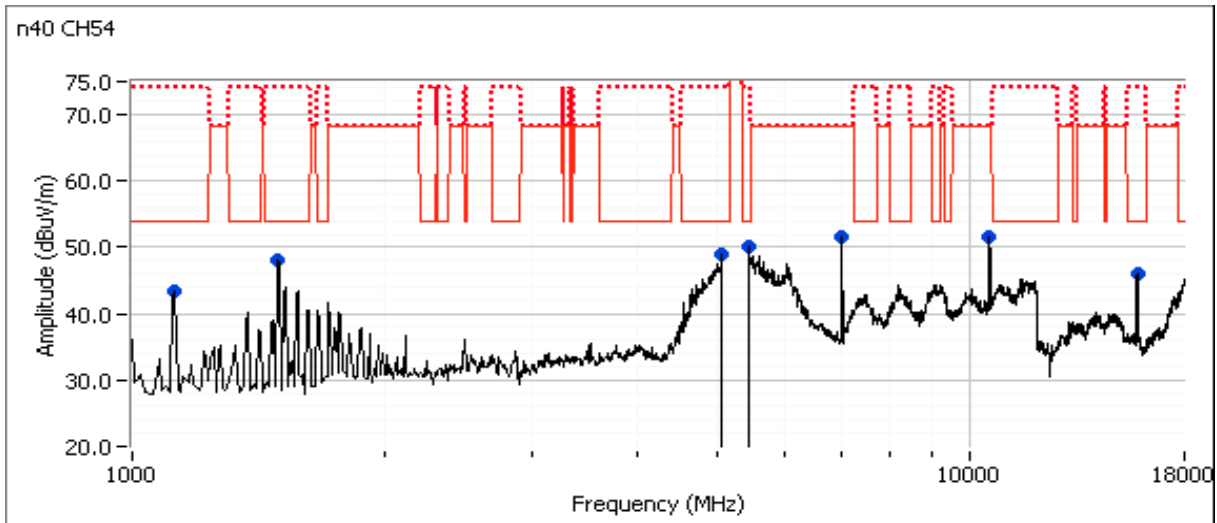



EMC Test Data

Client: Vivint Wireless	Job Number: J96161
Model: SR1530 (4x4 5GHz 802.11 AP)	T-Log Number: T97162
	Project Manager: Irene Rademacher
Contact: Venkat Kalkunte	Project Coordinator: -
Standard: FCC 15.B / 15.407 (New Rules)	Class: N/A

Run #3c: Center Channel

Channel: 58 Mode: ac80
 Tx Chain: 4x4 Data Rate: MCS8

Frequency MHz	Level dB μ V/m	Pol v/h	15.209 / 15E		Detector Pk/QP/Avg	Azimuth degrees	Height meters	Comments
			Limit	Margin				
5462.160	61.4	V	68.3	-6.9	PK	360	1.6	RB 1 MHz;VB 3 MHz;Peak
4640.090	40.5	V	54.0	-13.5	AVG	347	1.7	RB 1 MHz;VB 10 Hz;Peak
4639.950	50.9	V	74.0	-23.1	PK	347	1.7	RB 1 MHz;VB 3 MHz;Peak
7053.320	54.2	V	68.3	-14.1	PK	24	2.1	RB 1 MHz;VB 3 MHz;Peak
10606.170	46.2	H	54.0	-7.8	AVG	207	2.1	Note3; RB 1 MHz;VB 10 Hz;Peak
10607.030	59.3	H	74.0	-14.7	PK	207	2.1	RB 1 MHz;VB 3 MHz;Peak
1125.070	46.8	H	54.0	-7.2	AVG	206	1.9	RB 1 MHz;VB 10 Hz;Peak
1124.980	51.5	H	74.0	-22.5	PK	206	1.9	RB 1 MHz;VB 3 MHz;Peak
1500.070	38.3	V	54.0	-15.7	AVG	134	1.0	RB 1 MHz;VB 10 Hz;Peak
1500.000	42.9	V	74.0	-31.1	PK	134	1.0	RB 1 MHz;VB 3 MHz;Peak
15872.550	46.7	H	54.0	-7.3	AVG	203	1.5	Note3; RB 1 MHz;VB 10 Hz;Peak
15873.620	58.1	H	74.0	-15.9	PK	203	1.5	RB 1 MHz;VB 3 MHz;Peak
21160.210	49.4	H	54.0	-4.6	AVG	123	1.69	RB 1 MHz;VB 10 Hz;Peak
21160.290	54.7	H	74.0	-19.3	PK	123	1.69	RB 1 MHz;VB 3 MHz;Peak

Note 1: For emissions in restricted bands, the limit of 15.209 was used which requires average and peak measurements.

Client: Vivint Wireless	Job Number: J96161
Model: SR1530 (4x4 5GHz 802.11 AP)	T-Log Number: T97162
Contact: Venkat Kalkunte	Project Manager: Irene Rademacher
Standard: FCC 15.B / 15.407 (New Rules)	Project Coordinator: -
	Class: N/A

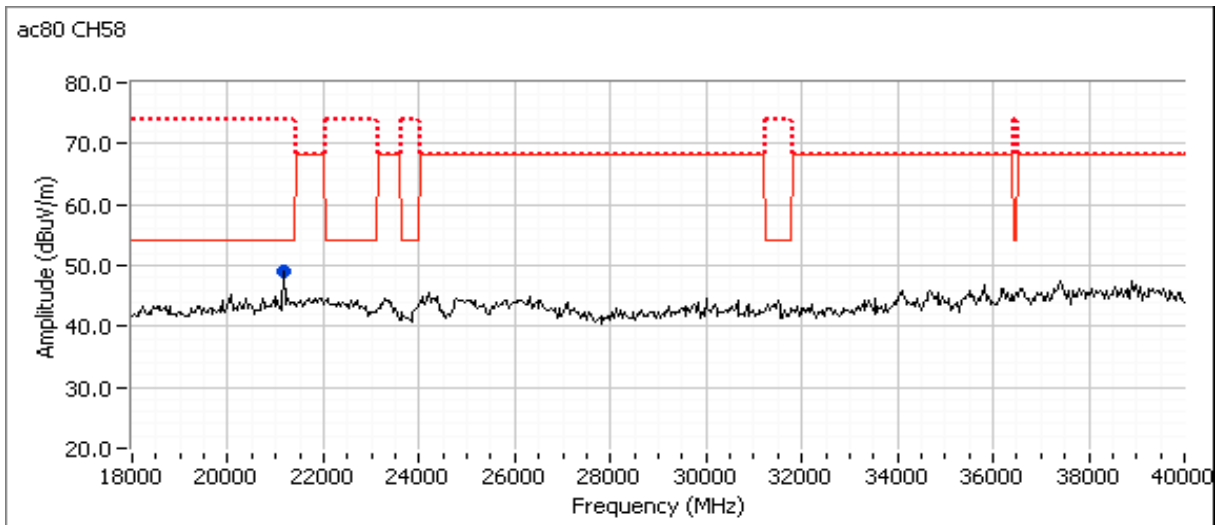
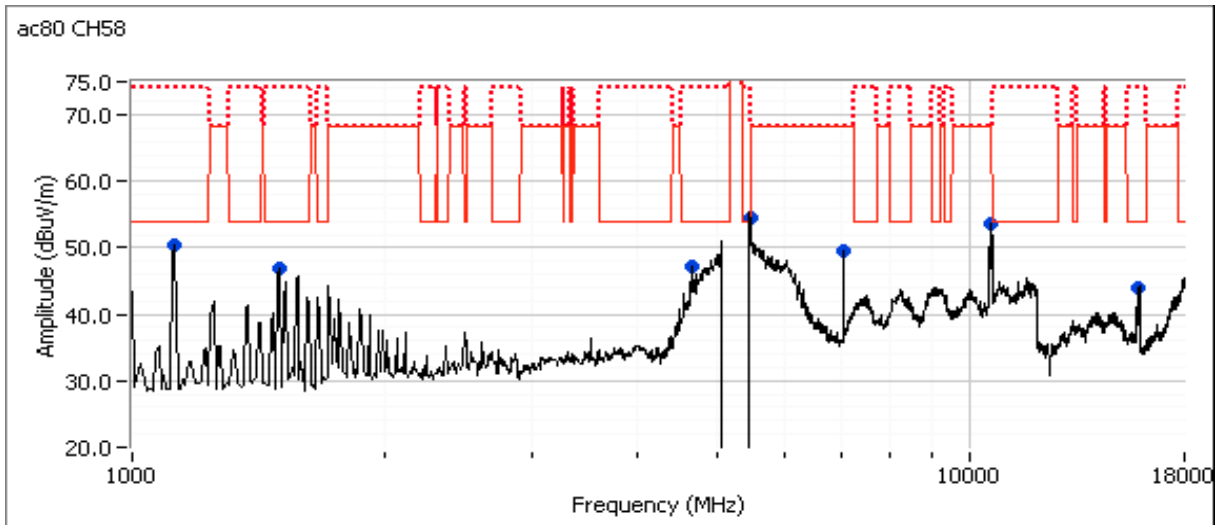

Client: Vivint Wireless	Job Number: J96161
Model: SR1530 (4x4 5GHz 802.11 AP)	T-Log Number: T97162
Contact: Venkat Kalkunte	Project Manager: Irene Rademacher
Standard: FCC 15.B / 15.407 (New Rules)	Project Coordinator: -
	Class: N/A

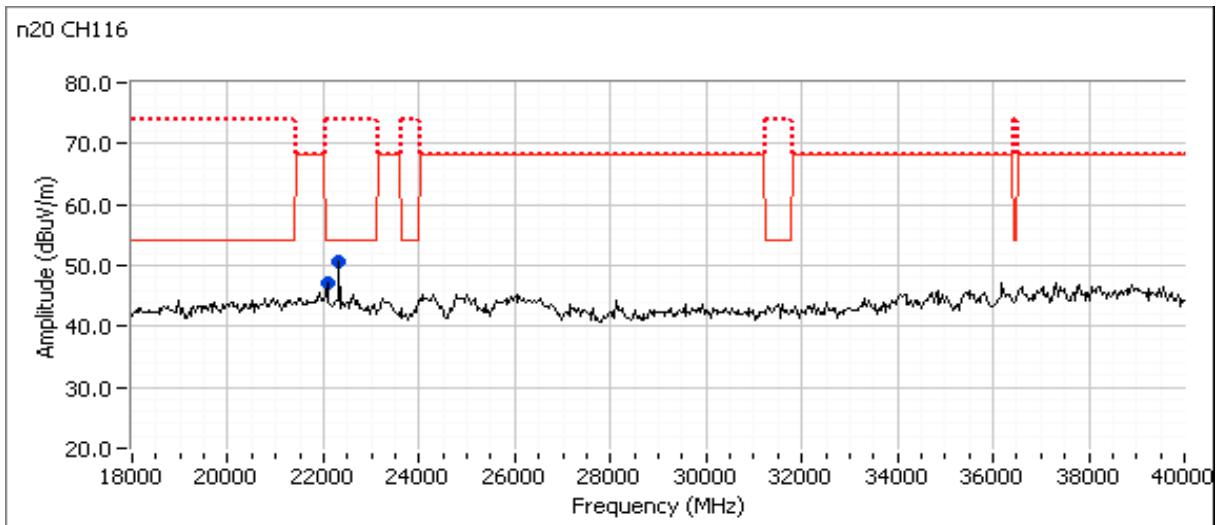
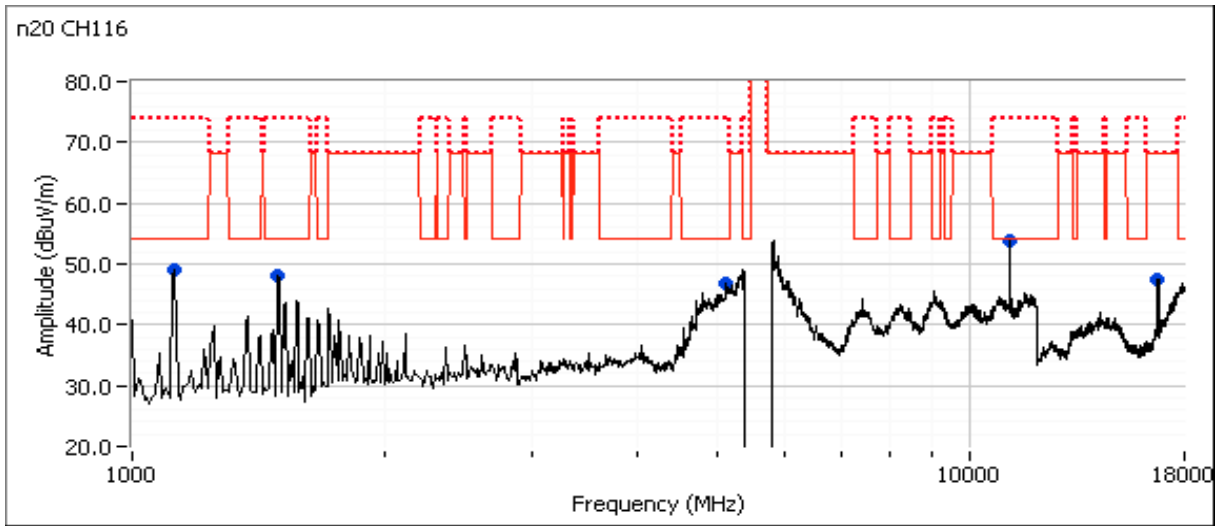



EMC Test Data

Client: Vivint Wireless	Job Number: J96161
Model: SR1530 (4x4 5GHz 802.11 AP)	T-Log Number: T97162
Contact: Venkat Kalkunte	Project Manager: Irene Rademacher
Standard: FCC 15.B / 15.407 (New Rules)	Project Coordinator: -
	Class: N/A

Run #5b: Center Channel

Channel: 110 Mode: 11n40
 Tx Chain: 4x4 Data Rate: MCS8

Frequency MHz	Level dB μ V/m	Pol v/h	15.209 / 15E		Detector PK/QP/Avg	Azimuth degrees	Height meters	Comments
			Limit	Margin				
5040.130	40.4	V	54.0	-13.6	AVG	6	1.8	Note3; RB 1 MHz;VB 10 Hz;Peak
5044.930	51.7	V	74.0	-22.3	PK	6	1.8	RB 1 MHz;VB 3 MHz;Peak
7400.130	44.1	V	54.0	-9.9	AVG	29	2.0	RB 1 MHz;VB 10 Hz;Peak
7400.120	53.2	V	74.0	-20.8	PK	29	2.0	RB 1 MHz;VB 3 MHz;Peak
1500.020	45.3	V	54.0	-8.7	AVG	216	2.4	RB 1 MHz;VB 10 Hz;Peak
1499.960	50.8	V	74.0	-23.2	PK	216	2.4	RB 1 MHz;VB 3 MHz;Peak
1124.990	45.5	H	54.0	-8.5	AVG	209	1.9	RB 1 MHz;VB 10 Hz;Peak
1125.000	50.9	H	74.0	-23.1	PK	209	1.9	RB 1 MHz;VB 3 MHz;Peak
11099.330	48.1	H	54.0	-5.9	AVG	232	2.0	Note3; RB 1 MHz;VB 10 Hz;Peak
11102.130	60.0	H	74.0	-14.0	PK	232	2.0	RB 1 MHz;VB 3 MHz;Peak
16642.530	59.0	H	68.3	-9.3	PK	284	1.82	RB 1 MHz;VB 3 MHz;Peak
22200.340	50.4	H	54.0	-3.6	AVG	120	1.56	RB 1 MHz;VB 10 Hz;Peak
22200.350	54.8	H	74.0	-19.2	PK	120	1.56	RB 1 MHz;VB 3 MHz;Peak

Note 1: For emissions in restricted bands, the limit of 15.209 was used which requires average and peak measurements.

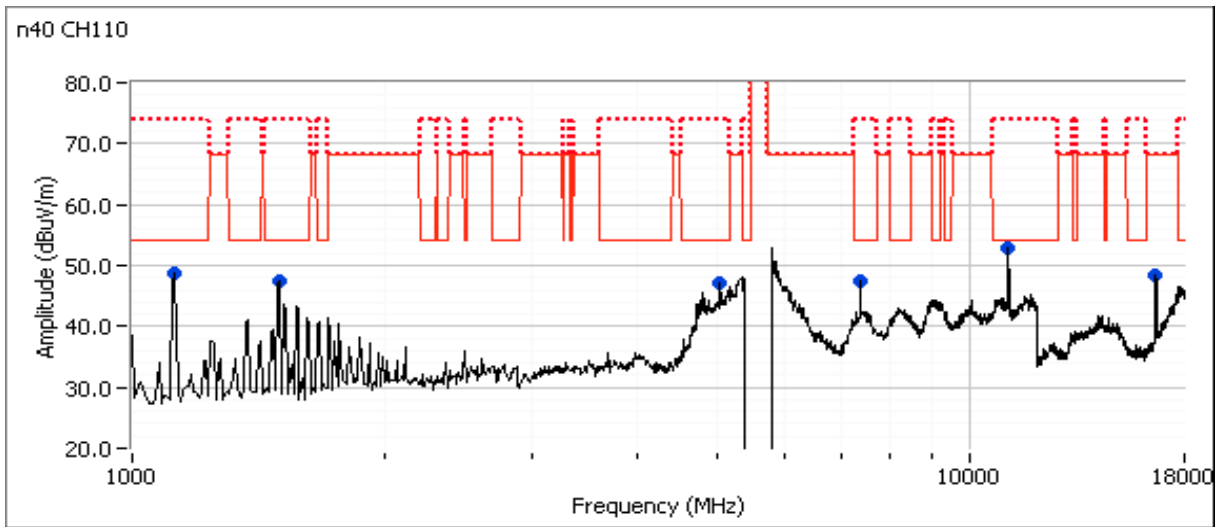

Client: Vivint Wireless	Job Number: J96161
Model: SR1530 (4x4 5GHz 802.11 AP)	T-Log Number: T97162
	Project Manager: Irene Rademacher
Contact: Venkat Kalkunte	Project Coordinator: -
Standard: FCC 15.B / 15.407 (New Rules)	Class: N/A

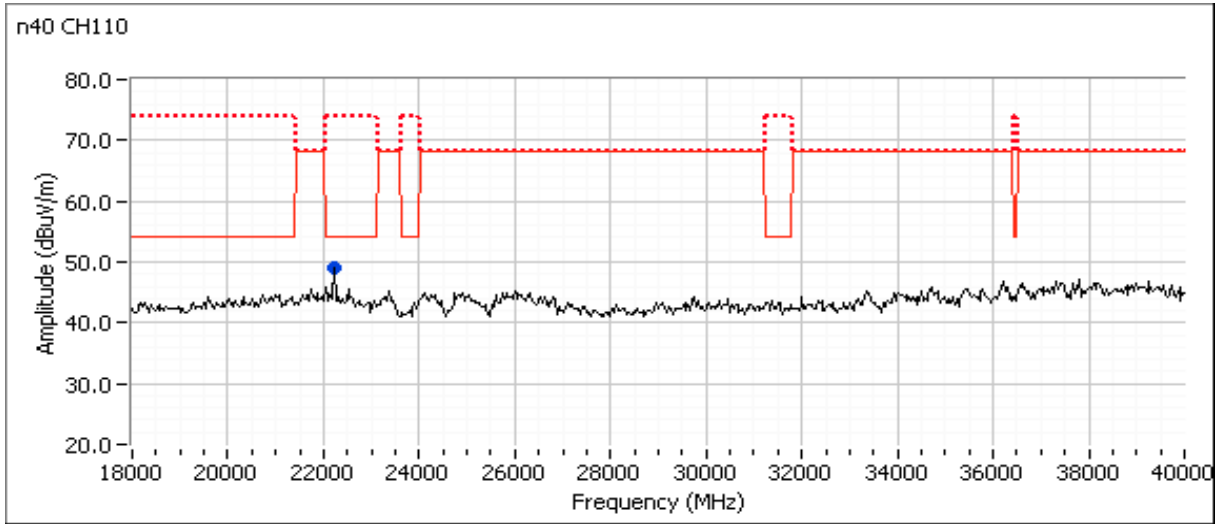



EMC Test Data

Client: Vivint Wireless	Job Number: J96161
Model: SR1530 (4x4 5GHz 802.11 AP)	T-Log Number: T97162
	Project Manager: Irene Rademacher
Contact: Venkat Kalkunte	Project Coordinator: -
Standard: FCC 15.B / 15.407 (New Rules)	Class: N/A

Run #5c: Center Channel

Channel: 122 Mode: ac80
 Tx Chain: 4x4 Data Rate: MCS8

Frequency MHz	Level dB μ V/m	Pol v/h	15.209 / 15E		Detector Pk/QP/Avg	Azimuth degrees	Height meters	Comments
			Limit	Margin				
1500.020	46.4	V	54.0	-7.6	AVG	212	2.3	RB 1 MHz;VB 10 Hz;Peak
1500.170	51.5	V	74.0	-22.5	PK	212	2.3	RB 1 MHz;VB 3 MHz;Peak
1125.050	45.5	H	54.0	-8.5	AVG	143	1.9	RB 1 MHz;VB 10 Hz;Peak
1125.050	50.2	H	74.0	-23.8	PK	143	1.9	RB 1 MHz;VB 3 MHz;Peak
5930.200	56.8	V	68.3	-11.5	PK	0	1.9	RB 1 MHz;VB 3 MHz;Peak
11194.670	44.0	H	54.0	-10.0	AVG	248	2.2	RB 1 MHz;VB 10 Hz;Peak
11194.000	56.2	H	74.0	-17.8	PK	248	2.2	RB 1 MHz;VB 3 MHz;Peak
7480.130	43.6	H	54.0	-10.4	AVG	254	1.9	RB 1 MHz;VB 10 Hz;Peak
7480.220	52.7	H	74.0	-21.3	PK	254	1.9	RB 1 MHz;VB 3 MHz;Peak
16830.130	56.3	H	68.3	-12.0	PK	250	1.73	RB 1 MHz;VB 3 MHz;Peak
22440.190	52.5	H	54.0	-1.5	AVG	121	1.50	RB 1 MHz;VB 10 Hz;Peak
22440.150	56.3	H	74.0	-17.7	PK	121	1.50	RB 1 MHz;VB 3 MHz;Peak

Note 1: For emissions in restricted bands, the limit of 15.209 was used which requires average and peak measurements.

Client: Vivint Wireless	Job Number: J96161
Model: SR1530 (4x4 5GHz 802.11 AP)	T-Log Number: T97162
Contact: Venkat Kalkunte	Project Manager: Irene Rademacher
Standard: FCC 15.B / 15.407 (New Rules)	Project Coordinator: -
	Class: N/A

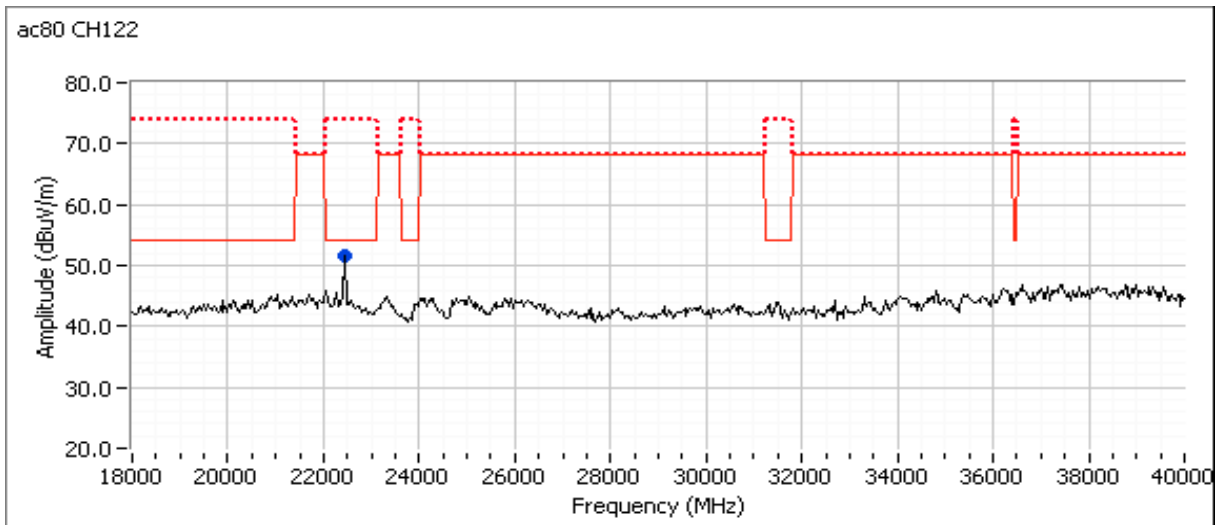
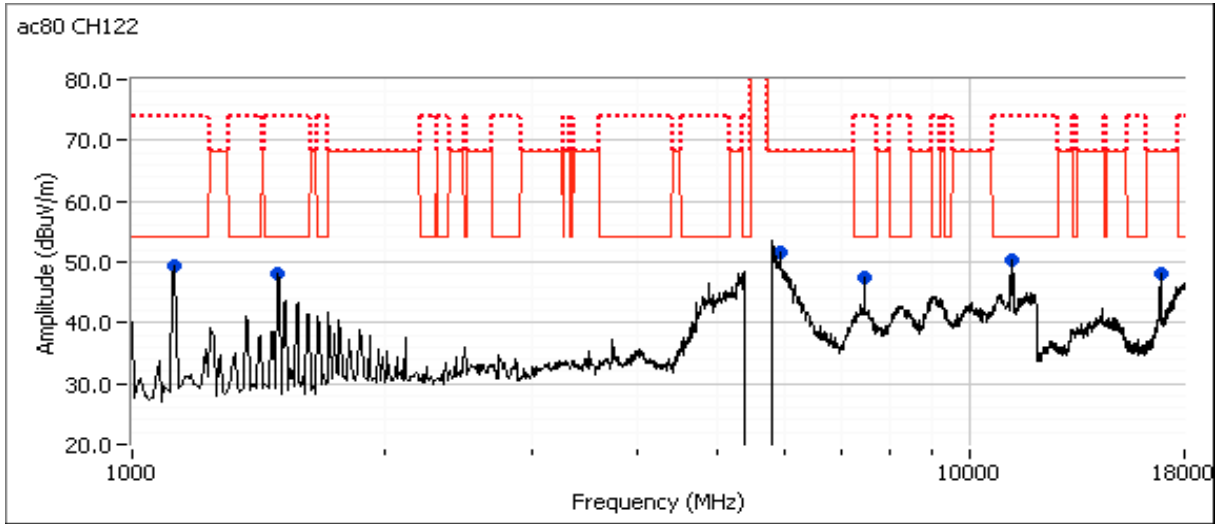



EMC Test Data

Client: Vivint Wireless	Job Number: J96161
Model: SR1530 (4x4 5GHz 802.11 AP)	T-Log Number: T97162
	Project Manager: Irene Rademacher
Contact: Venkat Kalkunte	Project Coordinator: -
Standard: FCC 15.B / 15.407 (New Rules)	Class: N/A

Run #7, Radiated Spurious Emissions, 1,000 - 40,000 MHz. Operation in the 5725-5850 MHz Band

Date of Test: 2/25/2015 0:00
 Test Engineer: Jack Liu
 Test Location: FT Chamber# 7

Config. Used: 1
 Config Change: -
 EUT Voltage: PoE

Run #7a: Center Channel

Channel: 157 Mode: 11n20
 Tx Chain: 4x4 Data Rate: MCS8

Frequency MHz	Level dB μ V/m	Pol v/h	15.209 / 15E		Detector Pk/QP/Avg	Azimuth degrees	Height meters	Comments
			Limit	Margin				
6025.050	57.1	V	68.3	-11.2	PK	2	1.8	RB 1 MHz;VB 3 MHz;Peak
1500.040	46.8	V	54.0	-7.2	AVG	220	2.3	RB 1 MHz;VB 10 Hz;Peak
1500.070	52.2	V	74.0	-21.8	PK	220	2.3	RB 1 MHz;VB 3 MHz;Peak
1125.040	46.2	H	54.0	-7.8	AVG	211	1.9	RB 1 MHz;VB 10 Hz;Peak
1124.950	51.0	H	74.0	-23.0	PK	211	1.9	RB 1 MHz;VB 3 MHz;Peak
11569.400	49.5	H	54.0	-4.5	AVG	219	2.4	Note3; RB 1 MHz;VB 10 Hz;Peak
11571.400	61.6	H	74.0	-12.4	PK	219	2.4	RB 1 MHz;VB 3 MHz;Peak
7713.430	41.6	H	54.0	-12.4	AVG	254	2.0	RB 1 MHz;VB 10 Hz;Peak
7713.370	50.6	H	74.0	-23.4	PK	254	2.0	RB 1 MHz;VB 3 MHz;Peak
17347.130	64.7	H	68.3	-3.6	PK	253	1.5	RB 1 MHz;VB 3 MHz;Peak
23140.450	56.1	H	68.3	-12.2	PK	119	1.51	RB 1 MHz;VB 3 MHz;Peak

Note 1: For emissions in restricted bands, the limit of 15.209 was used which requires average and peak measurements.

Client: Vivint Wireless	Job Number: J96161
Model: SR1530 (4x4 5GHz 802.11 AP)	T-Log Number: T97162
Contact: Venkat Kalkunte	Project Manager: Irene Rademacher
Standard: FCC 15.B / 15.407 (New Rules)	Project Coordinator: -
	Class: N/A

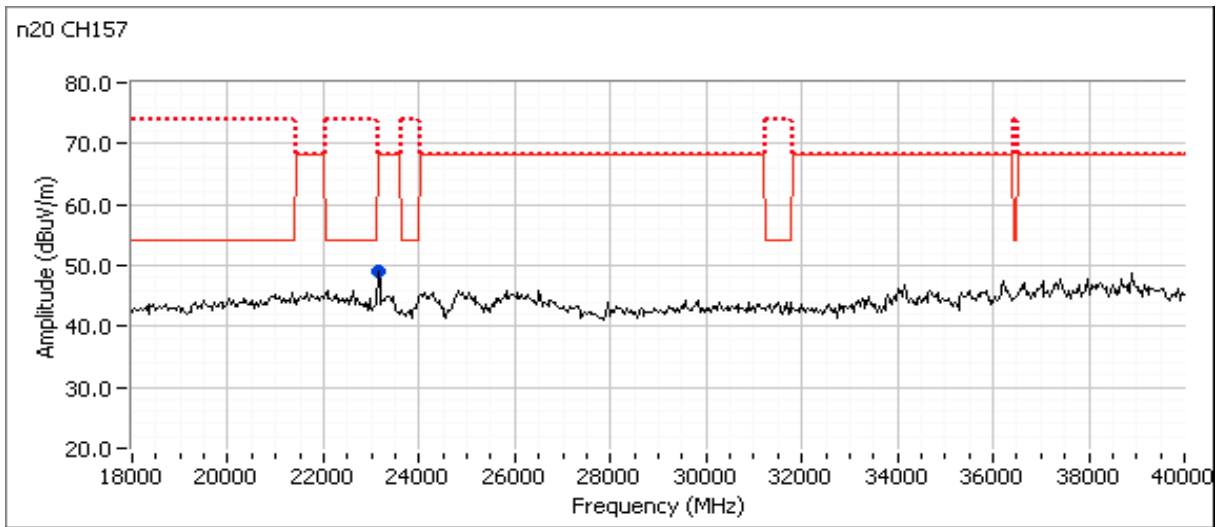
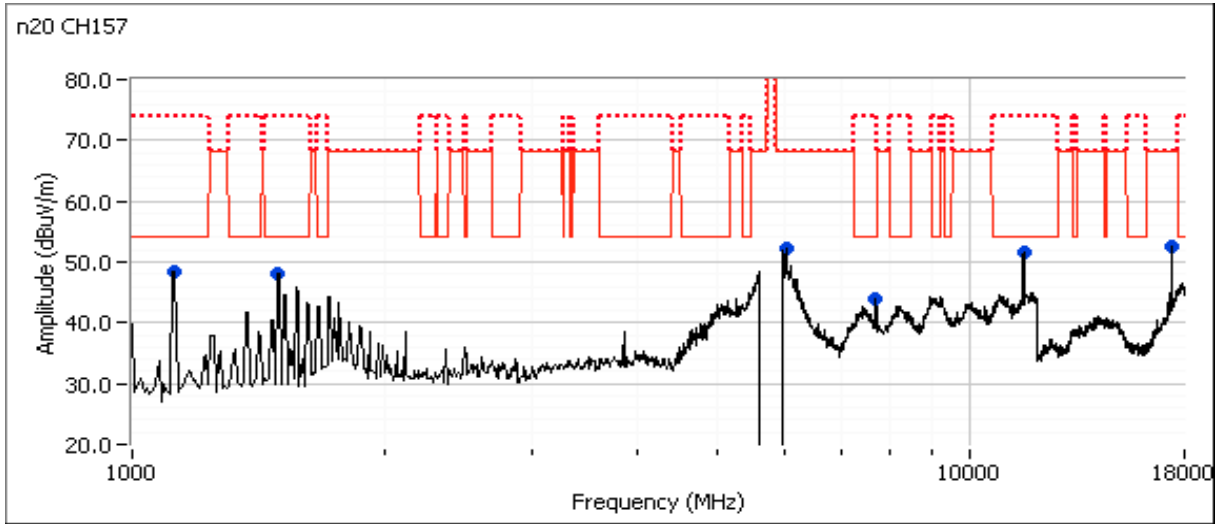



EMC Test Data

Client: Vivint Wireless	Job Number: J96161
Model: SR1530 (4x4 5GHz 802.11 AP)	T-Log Number: T97162
	Project Manager: Irene Rademacher
Contact: Venkat Kalkunte	Project Coordinator: -
Standard: FCC 15.B / 15.407 (New Rules)	Class: N/A

Run #7b: Center Channel

Channel: 159 Mode: 11n40
 Tx Chain: 4x4 Data Rate: MCS8

Frequency MHz	Level dB μ V/m	Pol v/h	15.209 / 15E		Detector PK/QP/Avg	Azimuth degrees	Height meters	Comments
			Limit	Margin				
6035.020	57.8	V	68.3	-10.5	PK	7	1.7	RB 1 MHz;VB 3 MHz;Peak
1125.010	46.0	H	54.0	-8.0	AVG	214	1.9	RB 1 MHz;VB 10 Hz;Peak
1125.060	50.9	H	74.0	-23.1	PK	214	1.9	RB 1 MHz;VB 3 MHz;Peak
1500.040	46.0	V	54.0	-8.0	AVG	217	2.0	RB 1 MHz;VB 10 Hz;Peak
1499.990	51.4	V	74.0	-22.6	PK	217	2.0	RB 1 MHz;VB 3 MHz;Peak
11599.430	49.5	H	54.0	-4.5	AVG	224	2.2	Note3; RB 1 MHz;VB 10 Hz;Peak
11601.530	61.9	H	74.0	-12.1	PK	224	2.2	RB 1 MHz;VB 3 MHz;Peak
3863.400	38.8	V	54.0	-15.2	AVG	354	1.6	RB 1 MHz;VB 10 Hz;Peak
3863.470	45.2	V	74.0	-28.8	PK	354	1.6	RB 1 MHz;VB 3 MHz;Peak
17375.730	63.6	H	68.3	-4.7	PK	252	1.50	RB 1 MHz;VB 3 MHz;Peak
23180.290	55.5	H	68.3	-12.8	PK	120	1.57	RB 1 MHz;VB 3 MHz;Peak

Note 1: For emissions in restricted bands, the limit of 15.209 was used which requires average and peak measurements.

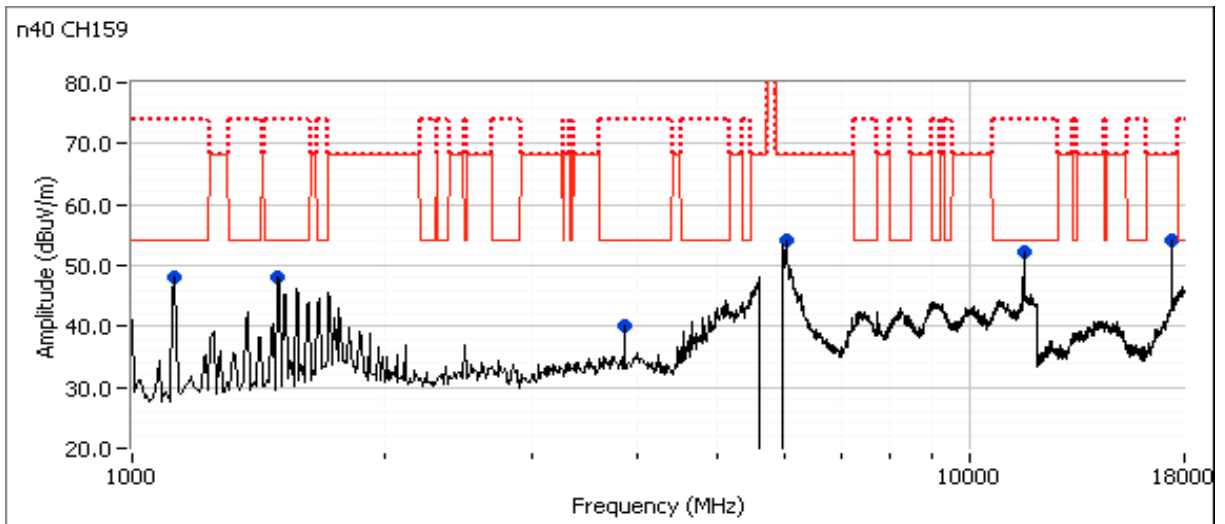

Client: Vivint Wireless	Job Number: J96161
Model: SR1530 (4x4 5GHz 802.11 AP)	T-Log Number: T97162
	Project Manager: Irene Rademacher
Contact: Venkat Kalkunte	Project Coordinator: -
Standard: FCC 15.B / 15.407 (New Rules)	Class: N/A

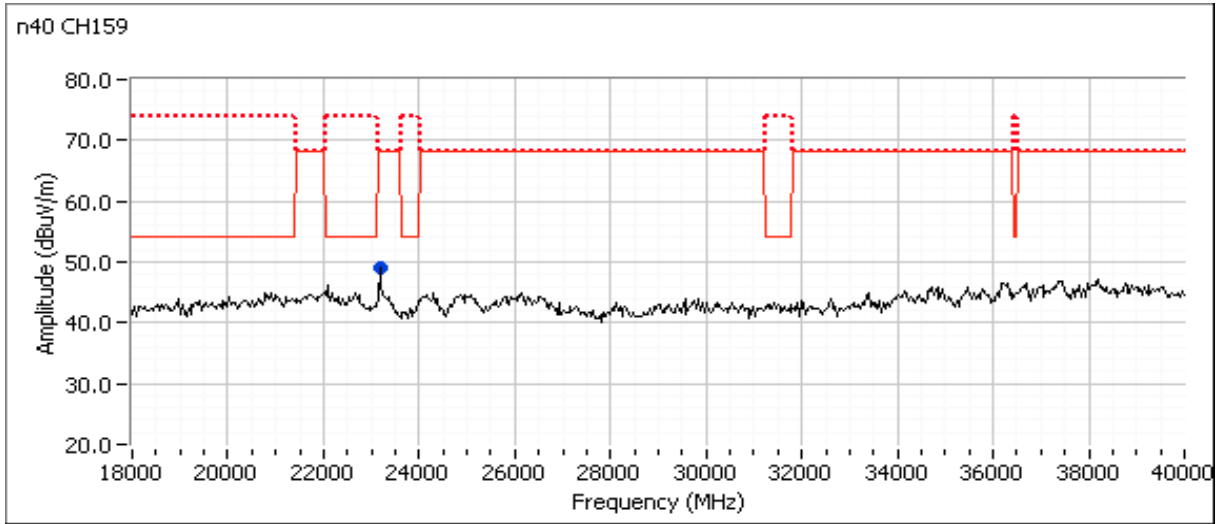



EMC Test Data

Client: Vivint Wireless	Job Number: J96161
Model: SR1530 (4x4 5GHz 802.11 AP)	T-Log Number: T97162
Contact: Venkat Kalkunte	Project Manager: Irene Rademacher
Standard: FCC 15.B / 15.407 (New Rules)	Project Coordinator: -
	Class: N/A

Run #7c: Center Channel

Channel: 155 Mode: ac80
 Tx Chain: 4x4 Data Rate: MCS8

Frequency MHz	Level dB μ V/m	Pol v/h	15.209 / 15E		Detector PK/QP/Avg	Azimuth degrees	Height meters	Comments
			Limit	Margin				
1500.020	47.6	V	54.0	-6.4	AVG	220	2.3	RB 1 MHz;VB 10 Hz;Peak
1499.980	52.9	V	74.0	-21.1	PK	220	2.3	RB 1 MHz;VB 3 MHz;Peak
11558.960	45.7	H	54.0	-8.3	AVG	218	2.4	Note3; RB 1 MHz;VB 10 Hz;Peak
11569.170	57.7	H	74.0	-16.3	PK	218	2.4	RB 1 MHz;VB 3 MHz;Peak
1125.040	46.4	H	54.0	-7.6	AVG	222	2.2	RB 1 MHz;VB 10 Hz;Peak
1124.980	51.2	H	74.0	-22.8	PK	222	2.2	RB 1 MHz;VB 3 MHz;Peak
7700.070	41.7	H	54.0	-12.3	AVG	267	1.9	RB 1 MHz;VB 10 Hz;Peak
7700.080	50.7	H	74.0	-23.3	PK	267	1.9	RB 1 MHz;VB 3 MHz;Peak
17365.470	64.7	H	68.3	-3.6	PK	250	1.48	RB 1 MHz;VB 3 MHz;Peak
23100.200	49.6	H	54.0	-4.4	AVG	235	1.62	RB 1 MHz;VB 10 Hz;Peak
23100.040	56.5	H	74.0	-17.5	PK	235	1.62	RB 1 MHz;VB 3 MHz;Peak

Note 1: For emissions in restricted bands, the limit of 15.209 was used which requires average and peak measurements.

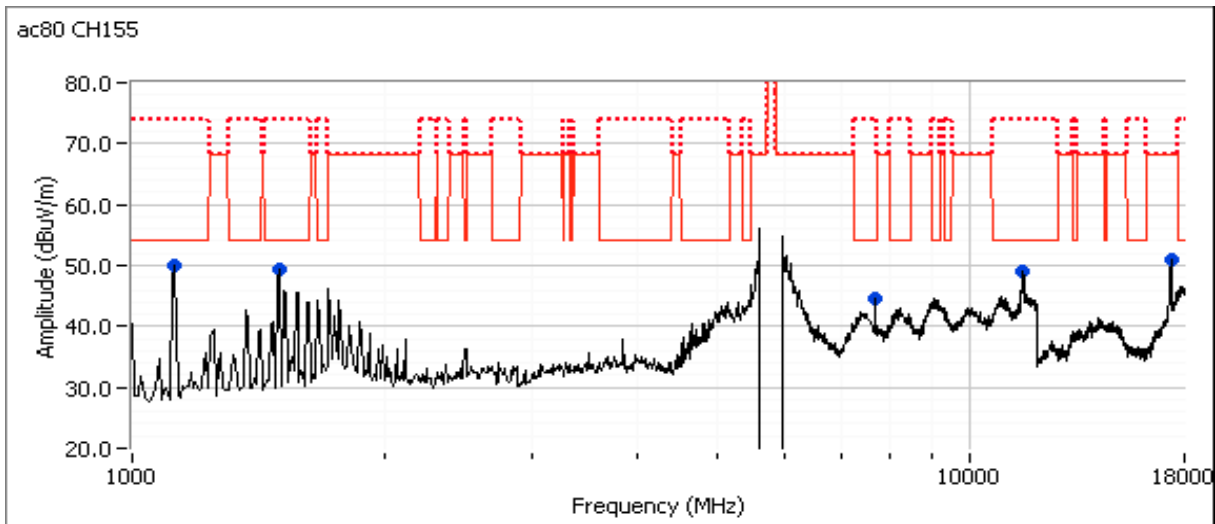

Client: Vivint Wireless	Job Number: J96161
Model: SR1530 (4x4 5GHz 802.11 AP)	T-Log Number: T97162
	Project Manager: Irene Rademacher
Contact: Venkat Kalkunte	Project Coordinator: -
Standard: FCC 15.B / 15.407 (New Rules)	Class: N/A

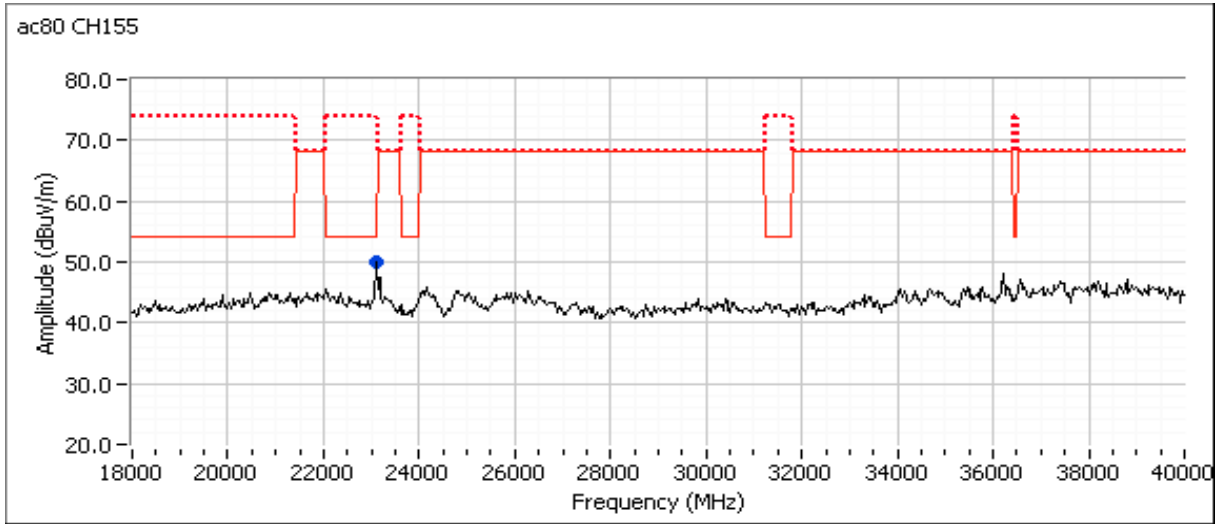

Client: Vivint Wireless	Job Number: J96161
Model: SR1530 (4x4 5GHz 802.11 AP)	T-Log Number: T97162
	Project Manager: Irene Rademacher
Contact: Venkat Kalkunte	Project Coordinator: -
Standard: FCC 15.B / 15.407 (New Rules)	Class: N/A

Run #8: Radiated Spurious Emissions, 1,000 - 40000 MHz. Operating Mode: Worse case from Run #7

Date of Test: 2/27/2015 0:00	Config. Used: 1
Test Engineer: Joseph Cadigal	Config Change: none
Test Location: FT Chamber#7	EUT Voltage: POE

Run #8a: Low Channel

Channel: 149 - 5745MHz	Mode: n20
Tx Chain: 4x4	Data Rate: MCS8

Frequency MHz	Level dB μ V/m	Pol v/h	15.209 / 15.247		Detector Pk/QP/Avg	Azimuth degrees	Height meters	Comments
			Limit	Margin				
22980.350	51.5	H	54.0	-2.5	AVG	120	1.6	RB 1 MHz;VB 10 Hz;Peak
22980.350	56.5	H	74.0	-17.5	PK	120	1.6	RB 1 MHz;VB 3 MHz;Peak
1125.090	46.2	H	54.0	-7.8	AVG	222	2.5	RB 1 MHz;VB 10 Hz;Peak
1125.280	51.5	H	74.0	-22.5	PK	222	2.5	RB 1 MHz;VB 3 MHz;Peak
7651.920	37.0	H	54.0	-17.0	AVG	111	1.5	RB 1 MHz;VB 10 Hz;Peak
7650.600	48.5	H	74.0	-25.5	PK	111	1.5	RB 1 MHz;VB 3 MHz;Peak
1500.060	43.3	V	54.0	-10.7	AVG	208	2.5	RB 1 MHz;VB 10 Hz;Peak
1500.120	49.1	V	74.0	-24.9	PK	208	2.5	RB 1 MHz;VB 3 MHz;Peak
11495.040	43.9	V	54.0	-10.1	AVG	245	2.0	note 3, RB 1 MHz;VB 10 Hz;Peak
11486.840	56.9	V	74.0	-17.1	PK	245	2.0	RB 1 MHz;VB 3 MHz;Peak

Note: Preliminary Scans made between 18 - 40 GHz with the measurement antenna moved around the card and its antennas 20-50cm from the device. Plot not included.

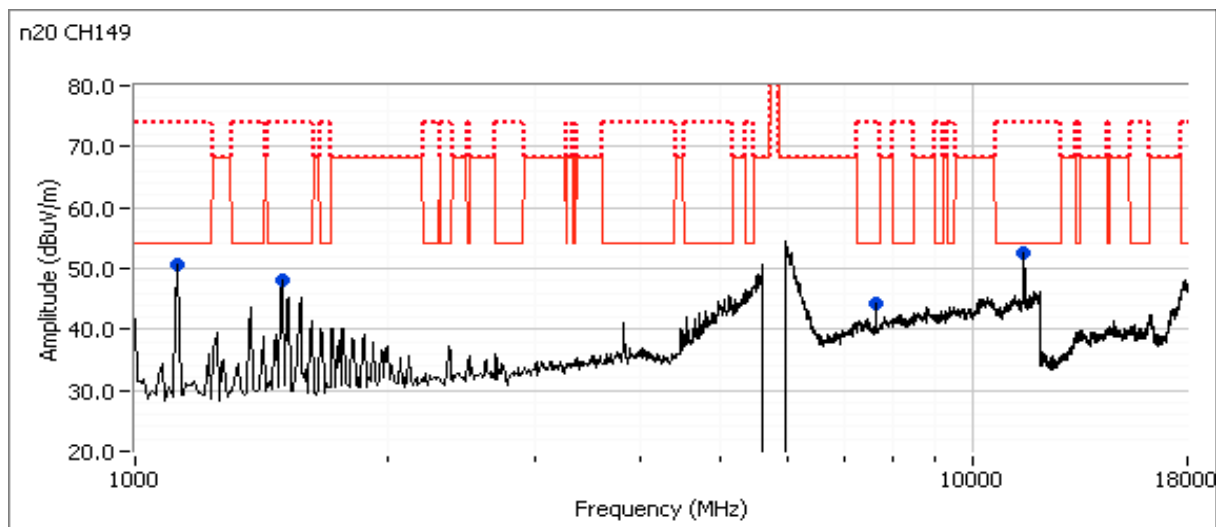

Client: Vivint Wireless	Job Number: J96161
Model: SR1530 (4x4 5GHz 802.11 AP)	T-Log Number: T97162
	Project Manager: Irene Rademacher
Contact: Venkat Kalkunte	Project Coordinator: -
Standard: FCC 15.B / 15.407 (New Rules)	Class: N/A

Run #8b: High Channel

Channel: 165 - 5825MHz Mode: n20
 Tx Chain: 4x4 Data Rate: MCS8

Frequency MHz	Level dB μ V/m	Pol v/h	15.209 / 15.247		Detector Pk/QP/Avg	Azimuth degrees	Height meters	Comments
			Limit	Margin				
11648.300	48.6	H	54.0	-5.4	AVG	229	2.5	note 3, RB 1 MHz; VB 10 Hz; Peak
11648.910	60.9	H	74.0	-13.1	PK	229	2.5	RB 1 MHz; VB 3 MHz; Peak
23300.650	51.9	H	68.3	-16.4	PK	146	1.6	RB 1 MHz; VB 3 MHz; Peak
1500.060	43.2	V	54.0	-10.8	AVG	212	2.5	RB 1 MHz; VB 10 Hz; Peak
1500.010	49.3	V	74.0	-24.7	PK	212	2.5	RB 1 MHz; VB 3 MHz; Peak
1125.060	45.6	H	54.0	-8.4	AVG	219	2.5	RB 1 MHz; VB 10 Hz; Peak
1125.190	50.5	H	74.0	-23.5	PK	219	2.5	RB 1 MHz; VB 3 MHz; Peak
3883.450	40.8	V	54.0	-13.2	AVG	360	2.0	RB 1 MHz; VB 10 Hz; Peak
3883.360	47.2	V	74.0	-26.8	PK	360	2.0	RB 1 MHz; VB 3 MHz; Peak

Note: Preliminary Scans made between 18 - 40 GHz with the measurement antenna moved around the card and its antennas 20-50cm from the device. Plot not included.

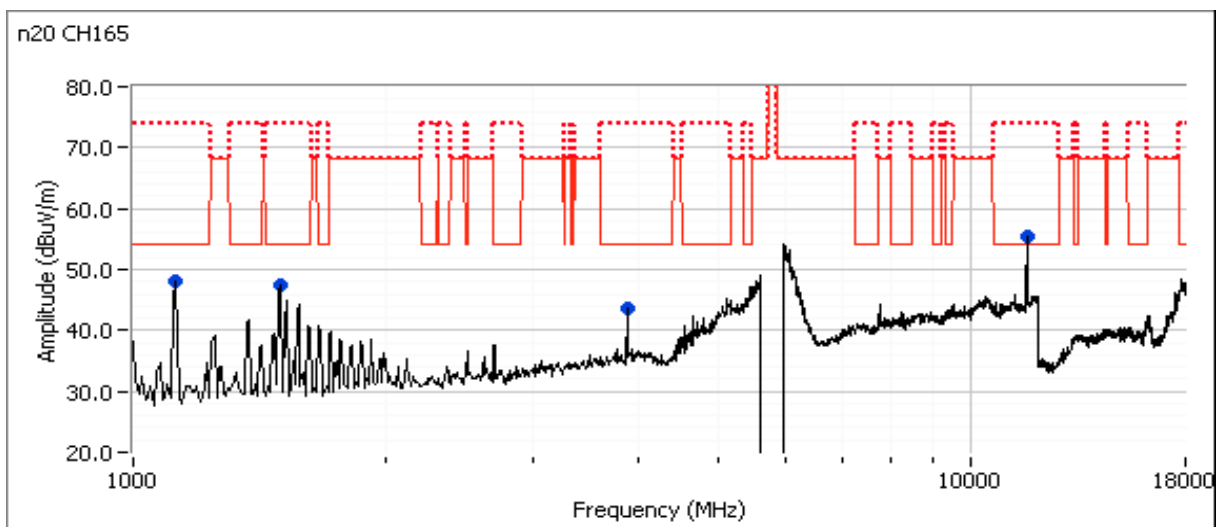



EMC Test Data

Client: Vivint Wireless	Job Number: J96161
Model: SR1530 (4x4 5GHz 802.11 AP)	T-Log Number: T97162
	Project Manager: Irene Rademacher
Contact: Venkat Kalkunte	Project Coordinator: -
Standard: FCC 15.B / 15.407 (New Rules)	Class: N/A

RSS-210 (LELAN) and FCC 15.407(UNII) Antenna Port Measurements Power, PSD, Peak Excursion, Bandwidth and Spurious Emissions

Test Specific Details

Objective: The objective of this test session is to perform final qualification testing of the EUT with respect to the specification listed above.

Summary of Results

Run #	Test Performed	Limit	Pass / Fail	Result / Margin
1	Power, 5150 - 5250MHz	15.407(a) (1) (i)	Pass	n20: 26.8 dBm (0.477W)
1	PSD, 5150 - 5250MHz	15.407(a) (1) (i)	Pass	n20: 13.6 dBm/MHz
1	Power, 5150 - 5250MHz	15.407(a) (1) (i)	Pass	n20: 83.4mW >30deg above horizon
1	Power, 5250 - 5350MHz	15.407(a) (2)	Pass	n20: 22.4 dBm (0.175W)
1	PSD, 5250 - 5350MHz	15.407(a) (2)	Pass	n20: 9.4dBm/MHz
1	Max EIRP 5250 - 5350MHz	TPC required if EIRP ≥ 500mW (27dBm). EIRP ≥ 200mW (23dBm) DFS threshold = -64dBm.	Pass	EIRP = 0.984W (29.9 dBm)
1	Power, 5470 - 5725MHz	15.407(a) (2)	Pass	n20: 21.9dBm (0.156W)
1	PSD, 5470 - 5725MHz	15.407(a) (2)	Pass	n20: 8.6dBm/MHz
1	Max EIRP 5470 - 5725MHz	TPC required if EIRP ≥ 500mW (27dBm). EIRP ≥ 200mW (23dBm) DFS threshold	Pass	EIRP = 0.988W (29.9 dBm)
1	Power, 5725 - 5850MHz	15.407(a) (3)	Pass	n20: 26.9dBm (0.494W)
1	PSD, 5725 - 5850MHz	15.407(a) (3)	Pass	n20: 13.7dBm/MHz
2	26dB Bandwidth	15.407(h)(2)	N/A	n20: 23.3MHz (minimum)
2	Minimum 6dB Bandwidth for UNII3 band	15.407(e)	Pass	n20: 17.6MHz



EMC Test Data

Client: Vivint Wireless	Job Number: J96161
Model: SR1530 (4x4 5GHz 802.11 AP)	T-Log Number: T97162
	Project Manager: Irene Rademacher
Contact: Venkat Kalkunte	Project Coordinator: -
Standard: FCC 15.B / 15.407 (New Rules)	Class: N/A

General Test Configuration

When measuring the conducted emissions from the EUT's antenna port, the antenna port of the EUT was connected to the spectrum analyzer or power meter via a suitable attenuator to prevent overloading the measurement system. All measurements are corrected to allow for the external attenuators and cables used.

Ambient Conditions:

Temperature: 21.4 °C
 Rel. Humidity: 39 %

Modifications Made During Testing

No modifications were made to the EUT during testing

Deviations From The Standard

No deviations were made from the requirements of the standard.

Procedure Comments:

Measurements performed in accordance with FCC KDB 789033

Mode	Data Rate	Duty Cycle (x)	Constant DC?	T (ms)	Pwr Cor Factor*	Lin Volt Cor Factor**	Min VBW for FS (Hz)
n20	6.5	96.5%	yes	2.54	0.16	0.31	394

Sample Notes

Sample S/N: Prototype

Driver: -



EMC Test Data

Client: Vivint Wireless	Job Number: J96161
Model: SR1530 (4x4 5GHz 802.11 AP)	T-Log Number: T97162
	Project Manager: Irene Rademacher
Contact: Venkat Kalkunte	Project Coordinator: -
Standard: FCC 15.B / 15.407 (New Rules)	Class: N/A

Antenna Gain Information

Freq	Antenna Gain (dBi) / Chain				BF	MultiChain Legacy	CDD	Sectorized / Xpol	Dir G (PWR)	Dir G (PSD)
	1	2	3	4						
5150-5250	4	4	4	4	Yes	No	Yes	No	7.0	7.0
5250-5350	4.5	4.5	4.5	4.5	Yes	No	Yes	No	7.5	7.5
5470-5725	5	5	5	5	Yes	No	Yes	No	8.0	8.0
5725-5850	5.5	5.5	5.5	5.5	Yes	No	Yes	No	8.5	8.5

For devices that support CDD modes

Min # of spatial streams: 2 MCS8 is the lowest rate supported
 Max # of spatial streams: 4

Notes:	BF = beamforming mode supported, Multichain Legacy = 802.11 legacy data rates supported for multichain transmissions, CDD = Cyclic Delay Diversity (or Cyclic Shift Diversity) modes supported, Sectorized / Xpol = antennas are sectorized or cross polarized.
Notes:	Dir G (PWR) = total gain (Gant + Array Gain) for power calculations; GA (PSD) = total gain for PSD calculations based on FCC KDB 662911. Depending on the modes supported, the Array Gain value for power could be different from the PSD value.
Notes:	Array gain for power/psd calculated per KDB 662911. Spatial Multiplexing with Nant=4, Nss=2, for worse case condition. Array gain = $10 \cdot \log(4/2) = 3\text{dB}$.

Note:

1. Antenna port number defined

Port JE09 -Test port 0 ; Port JE10 -Test port 1 ; Port JE11 -Test port 2 ; Port JE12 -Test port 3

2. All the measurements measured at the PCB connector, since the cables to the antennas were soldered.



EMC Test Data

Client: Vivint Wireless	Job Number: J96161
Model: SR1530 (4x4 5GHz 802.11 AP)	T-Log Number: T97162
	Project Manager: Irene Rademacher
Contact: Venkat Kalkunte	Project Coordinator: -
Standard: FCC 15.B / 15.407 (New Rules)	Class: N/A

Run #1: Bandwidth, Output Power and Power Spectral Density - MIMO Systems

Date of Test: 3/2/2015, 3/6/2015	Config. Used: 1
Test Engineer: John Caizzi Joseph Cadigal	Config Change: none
Test Location: Lab 4A	EUT Voltage: PoE

Note 1:	Output power measured using a spectrum analyzer (see plots below). RBW=1MHz, VB=3 MHz, # of points in sweep $\geq 2 \times \text{span}/\text{RBW}$, Sample or RMS detector, power averaging on and power integration and adjusted for duty cycle.
Note 2:	Measured using the same analyzer settings used for output power.
Note 3:	For RSS-210 the limit for the 5150 - 5250 MHz band accounts for the antenna gain as the maximum eirp allowed is 10dBm/MHz. The limits are also corrected for instances where the highest measured value of the PSD exceeds the average PSD (calculated from the measured power divided by the measured 99% bandwidth) by more than 3dB by the amount that the measured value exceeds the average by more than 3dB.
Note 4:	99% Bandwidth measured in accordance with RSS GEN - $\text{RB} > 1\%$ of span and $\text{VB} \geq 3 \times \text{RB}$
Note 5:	For MIMO systems the total output power and total PSD are calculated from the sum of the powers of the individual chains (in linear terms). The antenna gain used to determine the EIRP and limits for PSD/Output power depends on the operating mode of the MIMO device. If the signals on the non-coherent between the transmit chains then the gain used to determine the limits is the highest gain of the individual chains and the EIRP is the sum of the products of gain and power on each chain. If the signals are coherent then the effective antenna gain is the sum (in linear terms) of the gains for each chain and the EIRP is the product of the effective gain and total power.



EMC Test Data

Client: Vivint Wireless	Job Number: J96161
Model: SR1530 (4x4 5GHz 802.11 AP)	T-Log Number: T97162
	Project Manager: Irene Rademacher
Contact: Venkat Kalkunte	Project Coordinator: -
Standard: FCC 15.B / 15.407 (New Rules)	Class: N/A

MIMO Device - 5150-5250 MHz Band - FCC

Mode: n20

Max EIRP (mW): 2394.8

Frequency (MHz)	Chain	Software Setting	26dB BW (MHz)	Duty Cycle %	Power ¹ dBm	Total Power mW	dBm	FCC Limit dBm	Max Power (W)	Result
5180	0	21		96.5	20.5	472.0	26.7	29.0	0.477	Pass
	1				20.4					
	2				20.4					
	3				21.0					
5200	0	21		96.5	20.4	476.7	26.8	29.0		Pass
	1				20.6					
	2				20.6					
	3				20.8					
5240	0	21		96.5	19.2	347.2	25.4	29.0		Pass
	1				18.6					
	2				18.9					
	3				20.0					

5150-5250 PSD - FCC

Mode: n20

Frequency (MHz)	Chain	Software Setting	99% BW (MHz)	Duty Cycle %	PSD dBm/MHz	Total PSD ¹ mW/MHz	dBm/MHz	FCC Limit dBm/MHz	IC Limit dBm/MHz	Result
5180	0	21	18.1	96.5	7.3	22.6	13.5	16.0	-	Pass
	1				7.2					
	2				7.2					
	3				7.8					
5200	0	21	18.1	96.5	7.2	22.7	13.6	16.0	-	Pass
	1				7.4					
	2				7.3					
	3				7.6					
5240	0	21	18.1	96.5	6.5	18.9	12.8	16.0	-	Pass
	1				5.7					
	2				6.2					
	3				7.7					



EMC Test Data

Client: Vivint Wireless	Job Number: J96161
Model: SR1530 (4x4 5GHz 802.11 AP)	T-Log Number: T97162
Contact: Venkat Kalkunte	Project Manager: Irene Rademacher
Standard: FCC 15.B / 15.407 (New Rules)	Project Coordinator: -
	Class: N/A

Outdoor master devices are limited to 125mW (21dBm), 30deg above the horizon for all mounting configurations

Mode: n20

Max EIRP (mW): 83.4

Max Antenna gain 30deg above horizon: -7.57 dBi

Max EIRP (dBm): 19.2

Frequency (MHz)	Chain	Software Setting	26dB BW (MHz)	Duty Cycle %	Power ¹ dBm	Total Power		FCC Limit dBm (EIRP)	Max Power (W)	Result
						mW	dBm			
5180	0	21		96.5	20.5	472.0	26.7	21.0	0.477	Pass
	1				20.4					
	2				20.4					
	3				21.0					
5200	0	21		96.5	20.4	476.7	26.8	21.0	0.477	Pass
	1				20.6					
	2				20.6					
	3				20.8					
5240	0	21		96.5	19.2	347.2	25.4	21.0	0.477	Pass
	1				18.6					
	2				18.9					
	3				20.0					

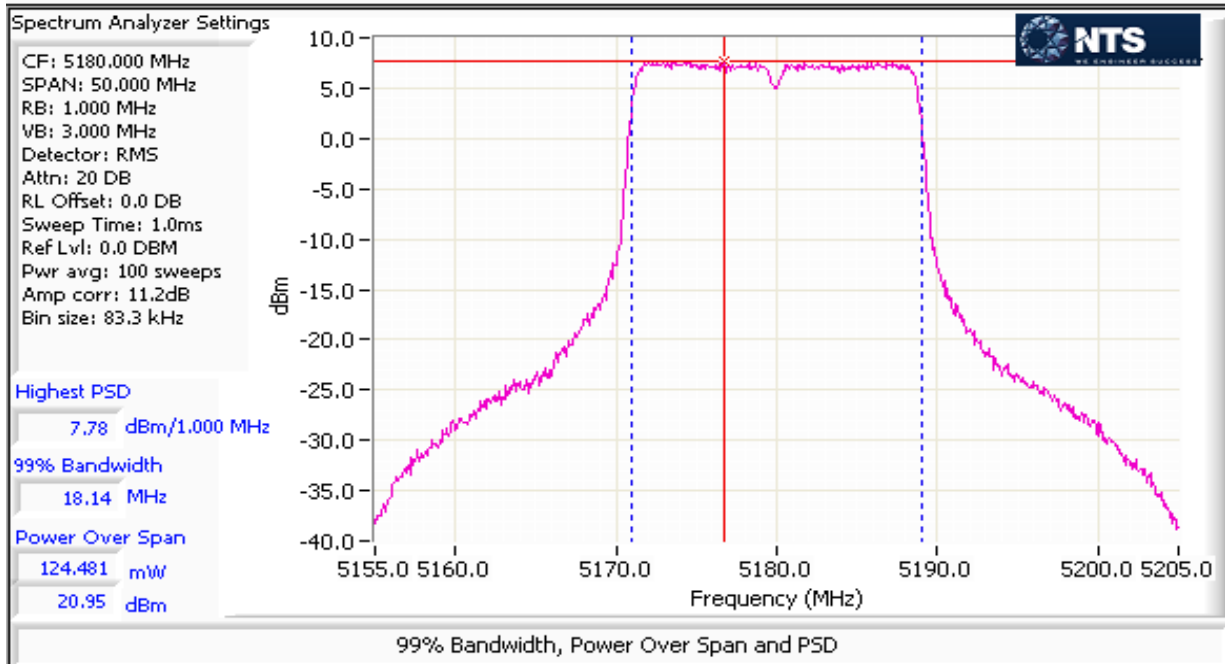



EMC Test Data

Client: Vivint Wireless	Job Number: J96161
Model: SR1530 (4x4 5GHz 802.11 AP)	T-Log Number: T97162
	Project Manager: Irene Rademacher
Contact: Venkat Kalkunte	Project Coordinator: -
Standard: FCC 15.B / 15.407 (New Rules)	Class: N/A

MIMO Device - 5250-5350 MHz Band - FCC

Mode: n20

Max EIRP (mW): 984.2

Frequency (MHz)	Chain	Software Setting	26dB BW (MHz)	Duty Cycle %	Power dBm	Total Power ¹ mW	dBm	FCC Limit dBm	Max Power (W)	Result
5260	0	19	27.4	96.5	16.1	174.6	22.4	22.5	0.175	Pass
	1				15.6					
	2				16.4					
	3				16.8					
5300	0	17	23.3	96.5	15.3	147.4	21.7	22.5		Pass
	1				15.5					
	2				15.5					
	3				15.7					
5320	0	17	23.3	96.5	15.9	162.4	22.1	22.5		Pass
	1				15.9					
	2				15.6					
	3				16.3					

MIMO Device 5250-5350 PSD - FCC

Mode: n20

Frequency (MHz)	Chain	Software Setting	99% BW (MHz)	Duty Cycle %	PSD dBm/MHz	Total PSD ¹ mW/MHz	dBm/MHz	FCC Limit dBm/MHz	IC Limit dBm/MHz	Result
5260	0	19	18.1	96.5	3.4	8.8	9.4	9.5	-	Pass
	1				2.9					
	2				3.3					
	3				3.5					
5300	0	17	18.1	96.5	2.0	7.2	8.6	9.5	-	Pass
	1				2.5					
	2				2.4					
	3				2.6					
5320	0	17	18.1	96.5	2.7	7.9	9.0	9.5	-	Pass
	1				2.7					
	2				2.6					
	3				3.2					

Client: Vivint Wireless	Job Number: J96161
Model: SR1530 (4x4 5GHz 802.11 AP)	T-Log Number: T97162
Contact: Venkat Kalkunte	Project Manager: Irene Rademacher
Standard: FCC 15.B / 15.407 (New Rules)	Project Coordinator: -
	Class: N/A

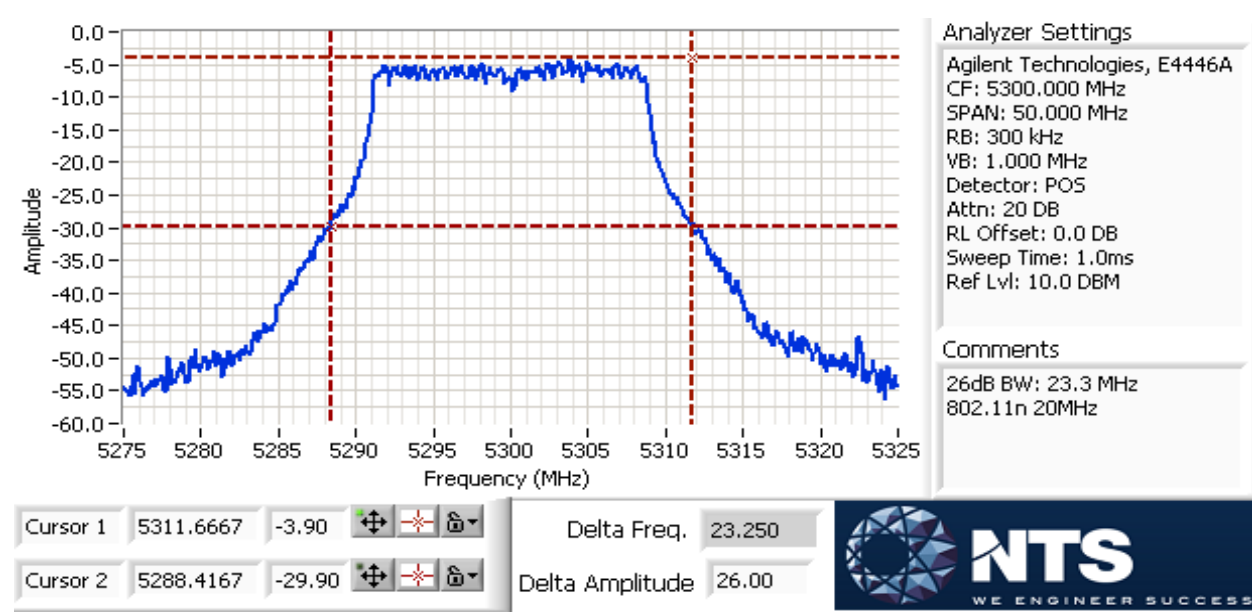
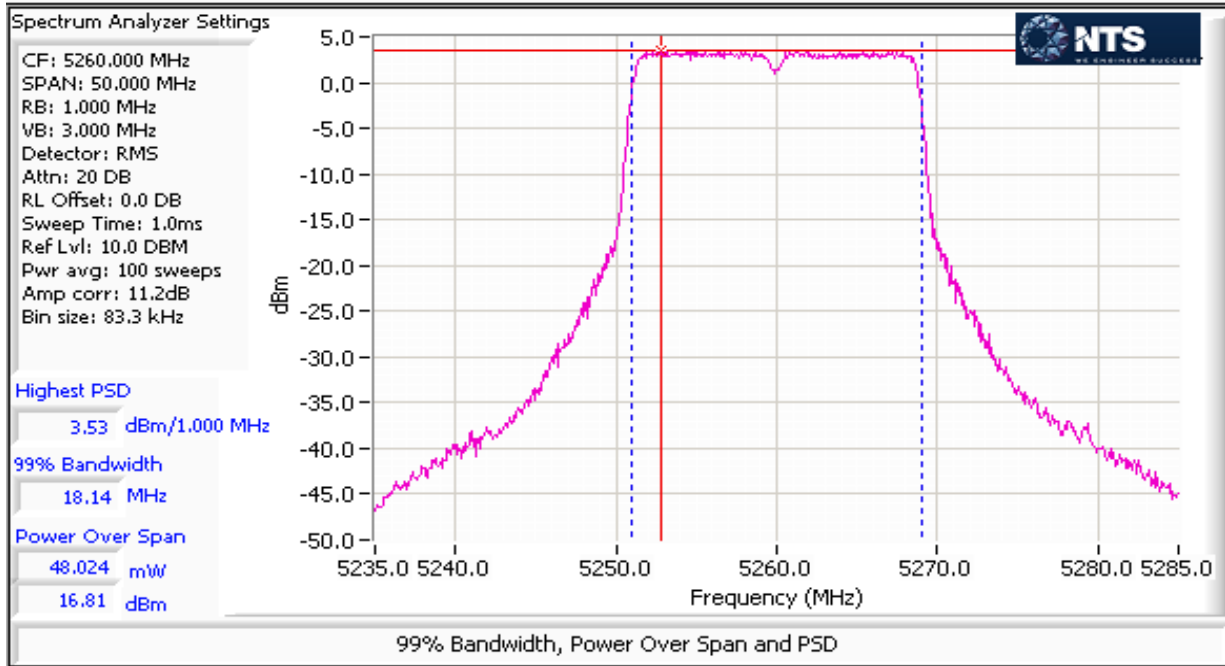



EMC Test Data

Client: Vivint Wireless	Job Number: J96161
Model: SR1530 (4x4 5GHz 802.11 AP)	T-Log Number: T97162
	Project Manager: Irene Rademacher
Contact: Venkat Kalkunte	Project Coordinator: -
Standard: FCC 15.B / 15.407 (New Rules)	Class: N/A

MIMO Device - 5470-5725 MHz Band - FCC

Mode: n20

Max EIRP (mW): 987.9

Frequency (MHz)	Chain	Software Setting	26dB BW (MHz)	Duty Cycle %	Power dBm	Total Power ¹ mW	FCC Limit dBm	Max Power (W)	Result	
5500	0	16	23.6	96.5	15.2	150.0	21.8	0.156	Pass	
	1				15.6					
	2				15.8					
	3				15.8					
5580	0	16	24.6	96.5	15.6	156.2	21.9		Pass	
	1				15.6					
	2				16.3					
	3				15.6					
5700	0	15	23.7	96.5	14.4	134.2	21.3		Pass	
	1				14.5					
	2				15.6					
	3				15.7					
802.11ac 20MHz										
UNII-2ext										
5720	0	15	23.42	96.5	13.9	109.6	20.4		Pass	
	1				13.6					
	2				14.4					
	3				14.9					
UNII-3										
5720	0	15	23.42	96.5	8.8	32.6	15.1	Pass		
	1				8.1					
	2				9.4					
	3				9.5					



EMC Test Data

Client: Vivint Wireless	Job Number: J96161
Model: SR1530 (4x4 5GHz 802.11 AP)	T-Log Number: T97162
	Project Manager: Irene Rademacher
Contact: Venkat Kalkunte	Project Coordinator: -
Standard: FCC 15.B / 15.407 (New Rules)	Class: N/A

MIMO Device 5470-5725 PSD - FCC

Mode: n20

Frequency (MHz)	Chain	Software Setting	99% BW (MHz)	Duty Cycle %	PSD dBm/MHz	Total PSD ¹ mW/MHz	Total PSD ¹ dBm/MHz	FCC Limit dBm/MHz	IC Limit dBm/MHz	Result
5500	0	16	18.1	96.5	2.0	7.3	8.6	9.0	-	Pass
	1				2.6					
	2				2.9					
	3				2.5					
5580	0	16	18.1	96.5	2.3	7.3	8.6	9.0	-	Pass
	1				2.3					
	2				3.1					
	3				2.3					
5700	0	15	18.1	96.5	1.2	6.4	8.1	9.0	-	Pass
	1				1.2					
	2				2.5					
	3				2.5					

802.11ac 20MHz

UNII-2ext

5720	0	15	14.06	96.5	2.6	6.6	8.2	9.0	-	Pass
	1				1.4					
	2				2.3					
	3				1.8					

UNII-3

5720	0	15	4.46	96.5	2.2	7.0	8.5	9.0	-	Pass
	1				1.3					
	2				2.7					
	3				2.7					

Client: Vivint Wireless	Job Number: J96161
Model: SR1530 (4x4 5GHz 802.11 AP)	T-Log Number: T97162
	Project Manager: Irene Rademacher
Contact: Venkat Kalkunte	Project Coordinator: -
Standard: FCC 15.B / 15.407 (New Rules)	Class: N/A

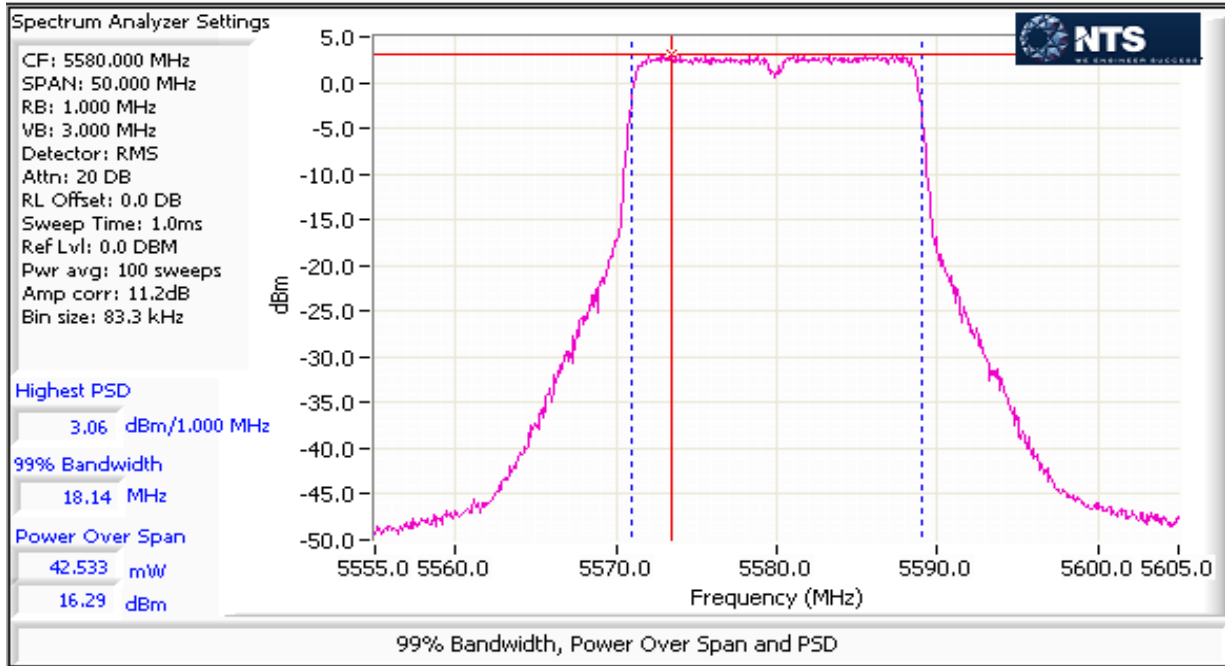

Client: Vivint Wireless	Job Number: J96161
Model: SR1530 (4x4 5GHz 802.11 AP)	T-Log Number: T97162
Contact: Venkat Kalkunte	Project Manager: Irene Rademacher
Standard: FCC 15.B / 15.407 (New Rules)	Project Coordinator: -
	Class: N/A

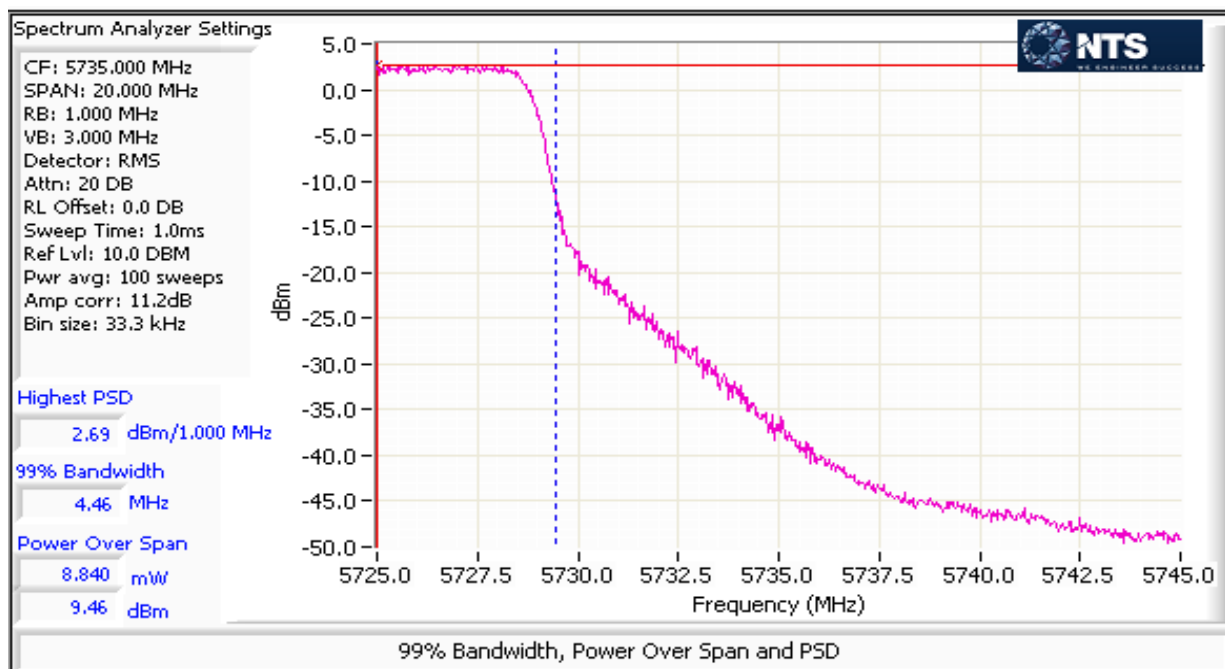
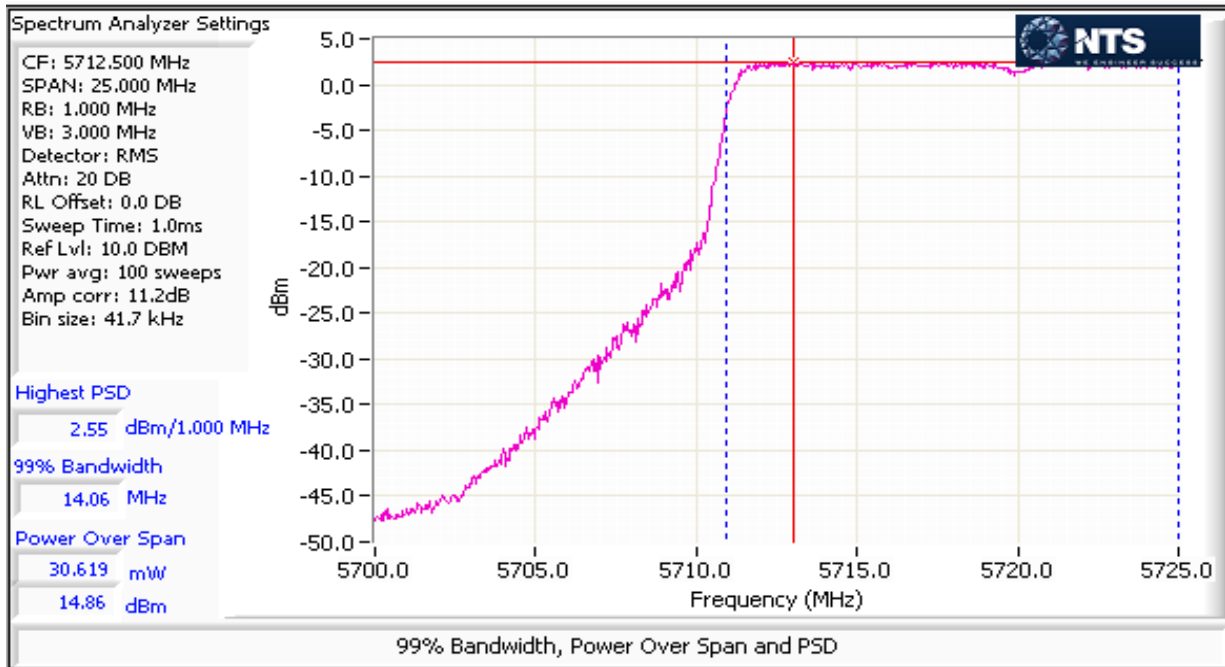



EMC Test Data

Client: Vivint Wireless	Job Number: J96161
Model: SR1530 (4x4 5GHz 802.11 AP)	T-Log Number: T97162
	Project Manager: Irene Rademacher
Contact: Venkat Kalkunte	Project Coordinator: -
Standard: FCC 15.B / 15.407 (New Rules)	Class: N/A

MIMO Device - 5725-580 MHz Band - FCC

Mode: n20

Max EIRP (mW): 3504.1

Frequency (MHz)	Chain	Software Setting	26dB BW (MHz)	Duty Cycle %	Power dBm	Total Power ¹ mW	dBm	FCC Limit dBm	Max Power (W)	Result
5745	0	19		96.5	18.7	325.6	25.1	27.5	0.494	Pass
	1				18.2					
	2				19.3					
	3				19.5					
5785	0	21		96.5	20.6	493.8	26.9	27.5		Pass
	1				20.4					
	2				21.0					
	3				21.1					
5825	0	20		96.5	19.2	374.2	25.7	27.5		Pass
	1				19.1					
	2				19.9					
	3				20.0					

MIMO Device 5725-5850 PSD - FCC

Mode: n20

Frequency (MHz)	Chain	Software Setting	99% BW (MHz)	Duty Cycle %	PSD dBm/MHz	Total PSD ¹ mW/MHz	dBm/MHz	FCC Limit dBm/500kHz	IC Limit	Result
5745	0	19	18.05	96.5	5.3	15.4	11.9	27.5	-	Pass
	1				5.0					
	2				6.1					
	3				6.3					
5785	0	21	18.14	96.5	7.2	23.5	13.7	27.5	-	Pass
	1				7.2					
	2				7.8					
	3				7.9					
5825	0	20	18.14	96.5	5.9	18.0	12.6	27.5	-	Pass
	1				5.9					
	2				6.6					
	3				7.0					

Client: Vivint Wireless	Job Number: J96161
Model: SR1530 (4x4 5GHz 802.11 AP)	T-Log Number: T97162
	Project Manager: Irene Rademacher
Contact: Venkat Kalkunte	Project Coordinator: -
Standard: FCC 15.B / 15.407 (New Rules)	Class: N/A

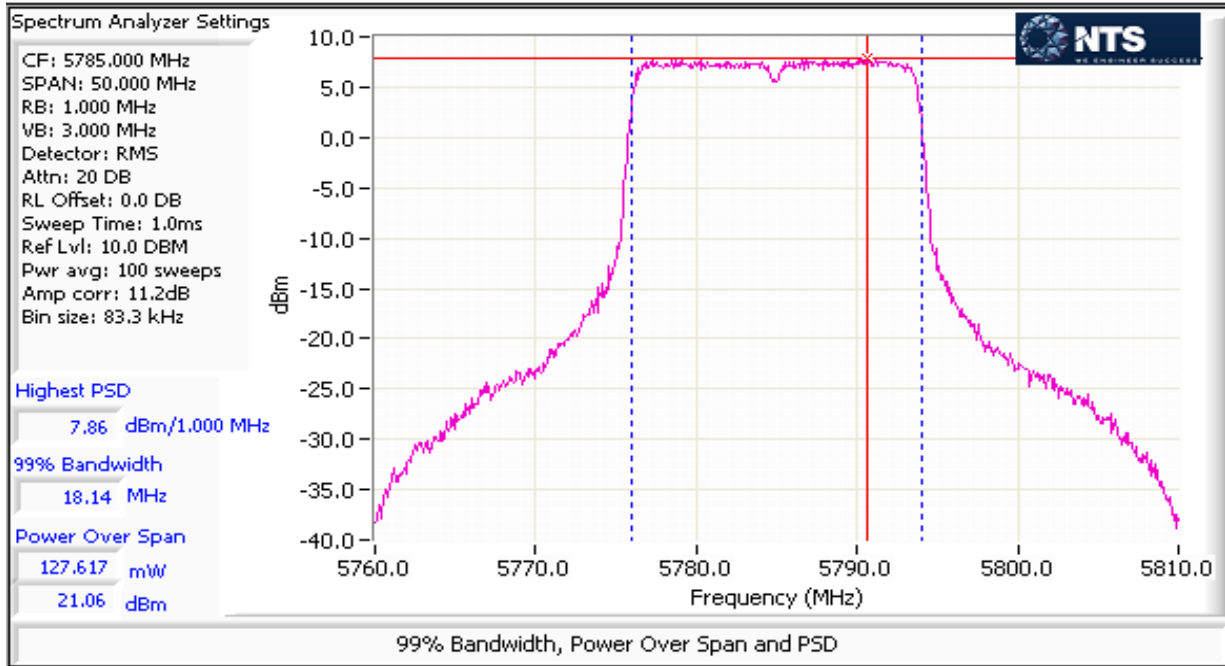

Client: Vivint Wireless	Job Number: J96161
Model: SR1530 (4x4 5GHz 802.11 AP)	T-Log Number: T97162
	Project Manager: Irene Rademacher
Contact: Venkat Kalkunte	Project Coordinator: -
Standard: FCC 15.B / 15.407 (New Rules)	Class: N/A

Run #2: Bandwidth Measurements

Date of Test: 3/6/2015 0:00 Config. Used: 1
 Test Engineer: Joseph Cadigal Config Change: none
 Test Location: FT Lab 4B EUT Voltage: POE

Mode: **HT20**
5725-5850MHz band (UNII3)
 Testing performed on port: 0

Power Setting	Frequency (MHz)	Bandwidth (MHz)		RBW Setting (MHz)	
		6dB	99%	6dB	99%
19	5745	17.6	18.1	0.1	1.0
21	5785	17.6	18.1	0.1	1.0
20	5825	17.7	18.1	0.1	1.0

Note 1: 6dB BW: RBW=100kHz, VBW ≥ 3*RBW, peak detector, max hold, auto sweep time.
 99% BW: RBW=1-5% of of 99%BW, VBW ≥ 3*RBW, peak detector, max hold, auto sweep time.

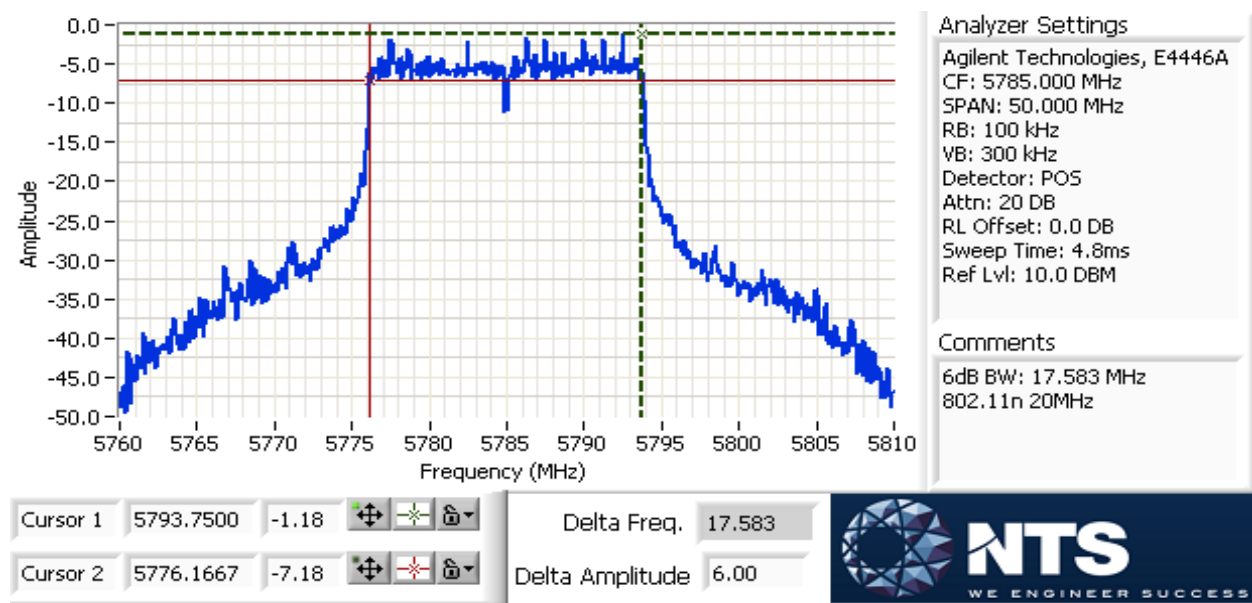



EMC Test Data

Client: Vivint Wireless	Job Number: J96161
Model: SR1530 (4x4 5GHz 802.11 AP)	T-Log Number: T97162
	Project Manager: Irene Rademacher
Contact: Venkat Kalkunte	Project Coordinator: -
Standard: FCC 15.B / 15.407 (New Rules)	Class: N/A

RSS-210 (LELAN) and FCC 15.407(UNII) Antenna Port Measurements Power, PSD, Peak Excursion, Bandwidth and Spurious Emissions

Test Specific Details

Objective: The objective of this test session is to perform final qualification testing of the EUT with respect to the specification listed above.

Summary of Results

Run #	Test Performed	Limit	Pass / Fail	Result / Margin
1	Power, 5150 - 5250MHz	15.407(a) (1) (i)	Pass	n40: 26.8dBm (0.483W)
1	PSD, 5150 - 5250MHz	15.407(a) (1) (i)	Pass	n40: 10.7dBm/MHz
1	Power, 5150 - 5250MHz	15.407(a) (1) (i)	Pass	n40: 84.5mW >30deg above horizon
1	Power, 5250 - 5350MHz	15.407(a) (2)	Pass	n40: 22.4dBm (0.174W)
1	PSD, 5250 - 5350MHz	15.407(a) (2)	Pass	n40: 6.2dBm/MHz
1	Max EIRP 5250 - 5350MHz	TPC required if EIRP ≥ 500mW (27dBm). EIRP ≥ 200mW (23dBm) DFS threshold = -64dBm.		EIRP = 0.979W (29.9dBm)
1	Power, 5470 - 5725MHz	15.407(a) (2)	Pass	n40: 21.5dBm (0.141W)
1	PSD, 5470 - 5725MHz	15.407(a) (2)	Pass	n40: 5.8dBm/MHz
1	Max EIRP 5470 - 5725MHz	TPC required if EIRP ≥ 500mW (27dBm). EIRP ≥ 200mW (23dBm) DFS threshold		EIRP = 0.891W (29.5dBm)
1	Power, 5725 - 5850MHz	15.407(a) (3)	Pass	n40: 25.8dBm (0.385W)
1	PSD, 5725 - 5850MHz	15.407(a) (3)	Pass	n40: 9.7dBm/MHz
2	26dB Bandwidth	15.407(h)(2)	N/A	n40: 40.67 MHz (minimum)
2	Minimum 6dB Bandwidth for UNII3 band	15.407(e)	Pass	n40: 36.27 MHz



EMC Test Data

Client: Vivint Wireless	Job Number: J96161
Model: SR1530 (4x4 5GHz 802.11 AP)	T-Log Number: T97162
	Project Manager: Irene Rademacher
Contact: Venkat Kalkunte	Project Coordinator: -
Standard: FCC 15.B / 15.407 (New Rules)	Class: N/A

General Test Configuration

When measuring the conducted emissions from the EUT's antenna port, the antenna port of the EUT was connected to the spectrum analyzer or power meter via a suitable attenuator to prevent overloading the measurement system. All measurements are corrected to allow for the external attenuators and cables used.

Ambient Conditions:

Temperature: 20.8 °C
 Rel. Humidity: 40 %

Modifications Made During Testing

No modifications were made to the EUT during testing

Deviations From The Standard

No deviations were made from the requirements of the standard.

Procedure Comments:

Measurements performed in accordance with FCC KDB 789033

Mode	Data Rate	Duty Cycle (x)	Constant DC?	T (ms)	Pwr Cor Factor*	Lin Volt Cor Factor**	Min VBW for FS (Hz)
n40	13.5	94.3%	yes	1.27	0.26	0.51	787

Sample Notes

Sample S/N: Prototype

Driver: -



EMC Test Data

Client: Vivint Wireless	Job Number: J96161
Model: SR1530 (4x4 5GHz 802.11 AP)	T-Log Number: T97162
	Project Manager: Irene Rademacher
Contact: Venkat Kalkunte	Project Coordinator: -
Standard: FCC 15.B / 15.407 (New Rules)	Class: N/A

Antenna Gain Information

Freq	Antenna Gain (dBi) / Chain				BF	MultiChain Legacy	CDD	Sectorized / Xpol	Dir G (PWR)	Dir G (PSD)
	1	2	3	4						
5150-5250	4	4	4	4	Yes	No	Yes	No	7.0	7.0
5250-5350	4.5	4.5	4.5	4.5	Yes	No	Yes	No	7.5	7.5
5470-5725	5	5	5	5	Yes	No	Yes	No	8.0	8.0
5725-5850	5.5	5.5	5.5	5.5	Yes	No	Yes	No	8.5	8.5

For devices that support CDD modes

Min # of spatial streams: 2 MCS8 is the lowest rate supported
 Max # of spatial streams: 4

Notes:	BF = beamforming mode supported, Multichain Legacy = 802.11 legacy data rates supported for multichain transmissions, CDD = Cyclic Delay Diversity (or Cyclic Shift Diversity) modes supported, Sectorized / Xpol = antennas are sectorized or cross polarized.
Notes:	Dir G (PWR) = total gain (Gant + Array Gain) for power calculations; GA (PSD) = total gain for PSD calculations based on FCC KDB 662911. Depending on the modes supported, the Array Gain value for power could be different from the PSD value.
Notes:	Array gain for power/psd calculated per DKB 662911. Spatial Multiplexing with Nant=4, Nss=2, for worse case condition. Array gain = $10 \cdot \log(4/2) = 3\text{dB}$.

Note:

1. Antenna port number defined

Port JE09 -Test port 0 ; Port JE10 -Test port 1 ; Port JE11 -Test port 2 ; Port JE12 -Test port 3

2. All the measurements measured at the end of the internal cable, not the output on the PCB board.



EMC Test Data

Client: Vivint Wireless	Job Number: J96161
Model: SR1530 (4x4 5GHz 802.11 AP)	T-Log Number: T97162
	Project Manager: Irene Rademacher
Contact: Venkat Kalkunte	Project Coordinator: -
Standard: FCC 15.B / 15.407 (New Rules)	Class: N/A

MIMO Device - 5150-5250 MHz Band - FCC

Mode: n40

Max EIRP (mW): 2425.5

Frequency (MHz)	Chain	Software Setting	26dB BW (MHz)	Duty Cycle %	Power ¹ dBm	Total Power mW	dBm	FCC Limit dBm	Max Power (W)	Result
5190	0	17		94.3	17.9	238.9	23.8	29.0	0.483	Pass
	1				17.4					
	2				17.3					
	3				17.4					
5230	0	21		94.3	21.3	482.8	26.8	29.0		Pass
	1				20.9					
	2				20.0					
	3				20.0					

5150-5250 PSD - FCC

Mode: n40

Frequency (MHz)	Chain	Software Setting	99% BW (MHz)	Duty Cycle %	PSD dBm/MHz	Total PSD ¹ mW/MHz	dBm/MHz	FCC Limit dBm/MHz	IC Limit dBm/MHz	Result
5190	0	17	36.47	94.3	1.5	5.7	7.6	16.0	-	Pass
	1				1.2					
	2				1.2					
	3				1.3					
5230	0	21	36.47	94.3	5.1	11.7	10.7	16.0	-	Pass
	1				4.8					
	2				3.8					
	3				3.8					



EMC Test Data

Client: Vivint Wireless	Job Number: J96161
Model: SR1530 (4x4 5GHz 802.11 AP)	T-Log Number: T97162
Contact: Venkat Kalkunte	Project Manager: Irene Rademacher
Standard: FCC 15.B / 15.407 (New Rules)	Project Coordinator: -
	Class: N/A

Outdoor master devices are limited to 125mW (21dBm), 30deg above the horizon for all mounting configurations

Mode: n40

Max EIRP (mW): 84.5

Max Antenna gain 30deg above horizon: -7.57 dBi

Max EIRP (dBm): 19.3

Frequency (MHz)	Chain	Software Setting	26dB BW (MHz)	Duty Cycle %	Power ¹ dBm	Total Power		FCC Limit dBm (EIRP)	Max Power (W)	Result
						mW	dBm			
5190	0	17		94.3	17.9	238.9	23.8	21.0	0.483	Pass
	1				17.4					
	2				17.3					
	3				17.4					
5230	0	21		94.3	21.3	482.8	26.8	21.0		Pass
	1				20.9					
	2				20.0					
	3				20.0					

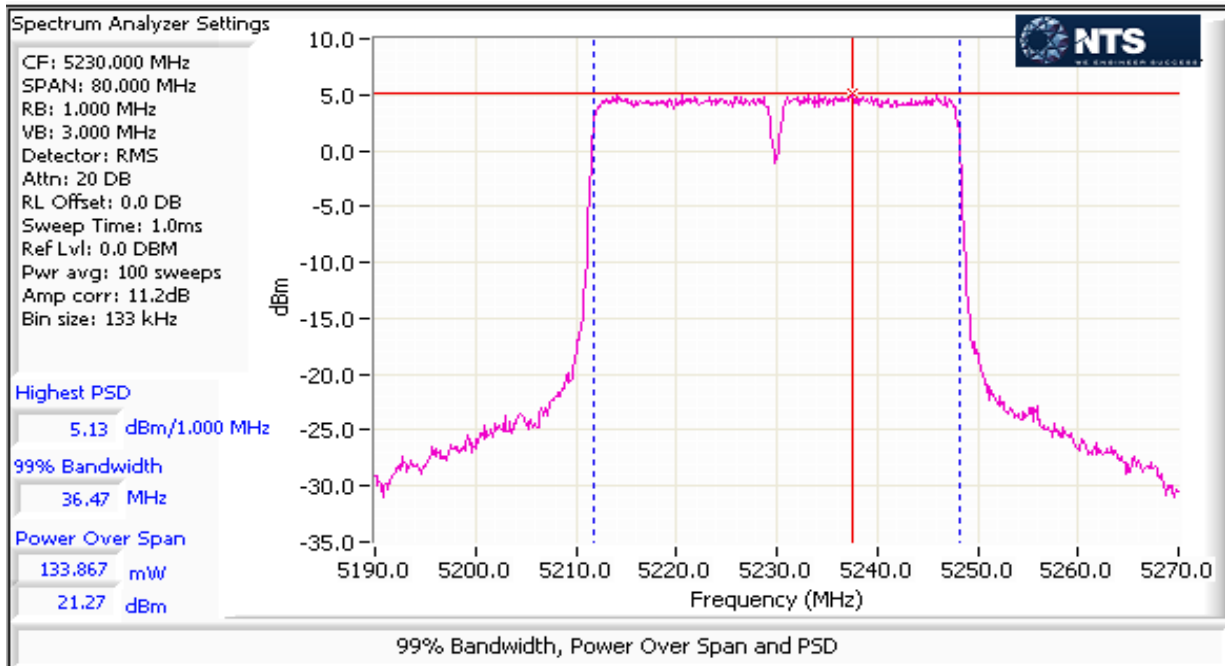



EMC Test Data

Client: Vivint Wireless	Job Number: J96161
Model: SR1530 (4x4 5GHz 802.11 AP)	T-Log Number: T97162
	Project Manager: Irene Rademacher
Contact: Venkat Kalkunte	Project Coordinator: -
Standard: FCC 15.B / 15.407 (New Rules)	Class: N/A

MIMO Device - 5250-5350 MHz Band - FCC

Mode: n40

Max EIRP (mW): 979.1

Frequency (MHz)	Chain	Software Setting	26dB BW (MHz)	Duty Cycle %	Power dBm	Total Power ¹ mW	dBm	FCC Limit dBm	Max Power (W)	Result
5270	0	16	41.333	94.3	16.1	173.7	22.4	22.5	0.174	Pass
	1				15.9					
	2				16.0					
	3				16.4					
5310	0	15	40.933	94.3	15.4	148.3	21.7	22.5		
	1				15.3					
	2				15.4					
	3				15.7					

MIMO Device 5250-5350 PSD - FCC

Mode: n40

Frequency (MHz)	Chain	Software Setting	99% BW (MHz)	Duty Cycle %	PSD dBm/MHz	Total PSD ¹ mW/MHz	dBm/MHz	FCC Limit dBm/MHz	IC Limit dBm/MHz	Result
5270	0	16	36.47	94.3	-0.1	4.2	6.2	9.5	-	Pass
	1				-0.3					
	2				-0.1					
	3				0.2					
5310	0	15	36.47	94.3	-0.8	3.6	5.6	9.5	-	Pass
	1				-0.9					
	2				-0.7					
	3				-0.4					

Client: Vivint Wireless	Job Number: J96161
Model: SR1530 (4x4 5GHz 802.11 AP)	T-Log Number: T97162
	Project Manager: Irene Rademacher
Contact: Venkat Kalkunte	Project Coordinator: -
Standard: FCC 15.B / 15.407 (New Rules)	Class: N/A

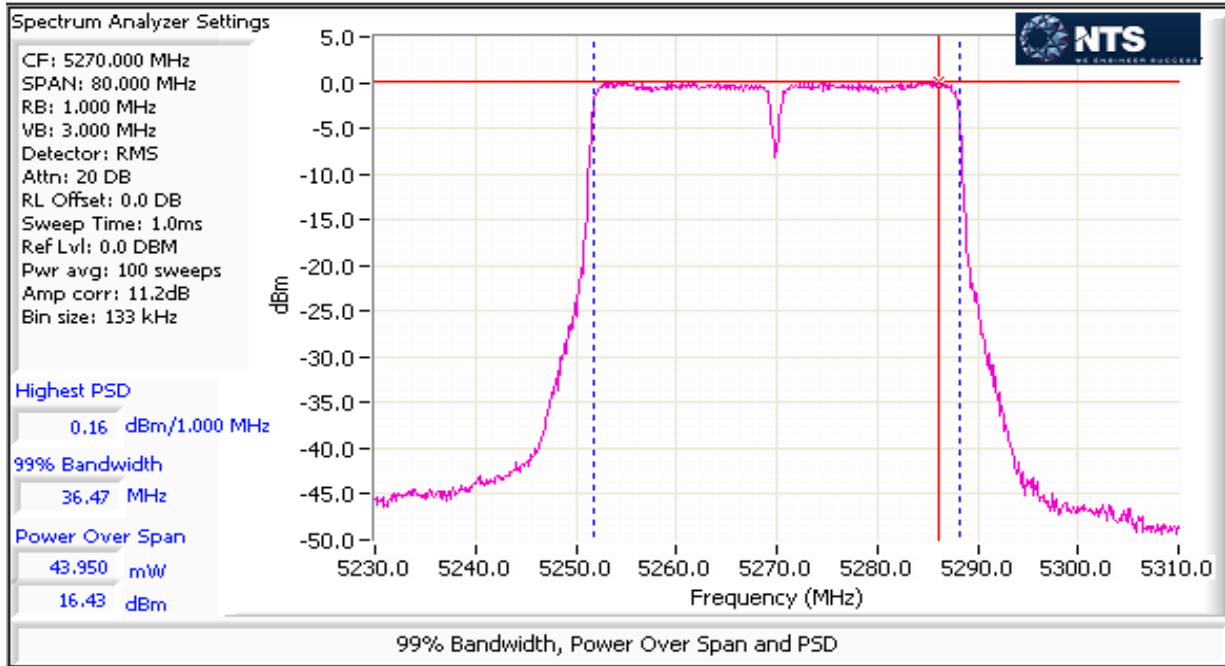



EMC Test Data

Client: Vivint Wireless	Job Number: J96161
Model: SR1530 (4x4 5GHz 802.11 AP)	T-Log Number: T97162
	Project Manager: Irene Rademacher
Contact: Venkat Kalkunte	Project Coordinator: -
Standard: FCC 15.B / 15.407 (New Rules)	Class: N/A

MIMO Device - 5470-5725 MHz Band - FCC

Mode: n40

Max EIRP (mW): 890.5

Frequency (MHz)	Chain	Software Setting	26dB BW (MHz)	Duty Cycle %	Power dBm	Total Power ¹ mW	FCC Limit dBm	Max Power (W)	Result
5510	0	15	41.6	94.3	14.6	139.6	21.4	0.141	Pass
	1				15.0				
	2				15.8				
	3				15.2				
5550	0	15	40.67	94.3	14.6	140.3	21.5		Pass
	1				15.0				
	2				15.9				
	3				15.2				
5670	0	15	40.93	94.3	14.6	140.0	21.5		Pass
	1				15.1				
	2				15.9				
	3				15.1				
802.11ac 40MHz									
UNII-2ext									
5710	0	15	41	94.3	14.7	140.8	21.5	Pass	
	1				14.3				
	2				15.8				
	3				15.9				
UNII-3									
5710	0	15	41	94.3	5.0	14.7	11.7	Pass	
	1				4.7				
	2				5.9				
	3				6.0				



EMC Test Data

Client: Vivint Wireless	Job Number: J96161
Model: SR1530 (4x4 5GHz 802.11 AP)	T-Log Number: T97162
	Project Manager: Irene Rademacher
Contact: Venkat Kalkunte	Project Coordinator: -
Standard: FCC 15.B / 15.407 (New Rules)	Class: N/A

MIMO Device 5470-5725 PSD - FCC

Mode: n40

Frequency (MHz)	Chain	Software Setting	99% BW (MHz)	Duty Cycle %	PSD dBm/MHz	Total PSD ¹		FCC Limit dBm/MHz	IC Limit dBm/MHz	Result
						mW/MHz	dBm/MHz			
5510	0	15	36.47	94.3	-1.6	3.4	5.3	9.0	-	Pass
	1				-1.1					
	2				-0.4					
	3				-1.0					
5550	0	15	36.47	94.3	-1.5	3.5	5.4	9.0	-	Pass
	1				-1.2					
	2				-0.1					
	3				-0.8					
5670	0	15	36.47	94.3	-1.6	3.4	5.3	9.0	-	Pass
	1				-1.2					
	2				-0.1					
	3				-1.2					

802.11ac 40MHz

UNII-2ext

5710	0	15	33.19	94.3	-1.0	3.7	5.7	9.0	-	Pass
	1				-1.5					
	2				-0.01					
	3				0.2					

UNII-3

5710	0	15	33.19	94.3	-0.9	3.8	5.8	9.0	-	Pass
	1				-1.1					
	2				-0.03					
	3				-0.04					

Client: Vivint Wireless	Job Number: J96161
Model: SR1530 (4x4 5GHz 802.11 AP)	T-Log Number: T97162
Contact: Venkat Kalkunte	Project Manager: Irene Rademacher
Standard: FCC 15.B / 15.407 (New Rules)	Project Coordinator: -
	Class: N/A

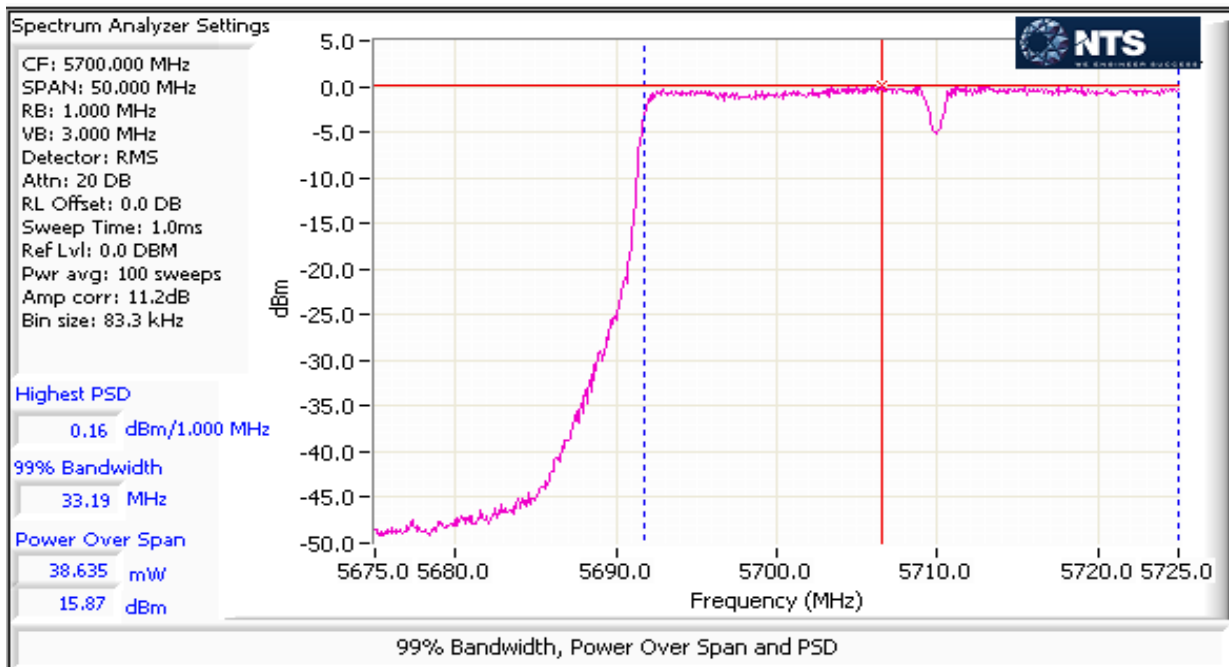
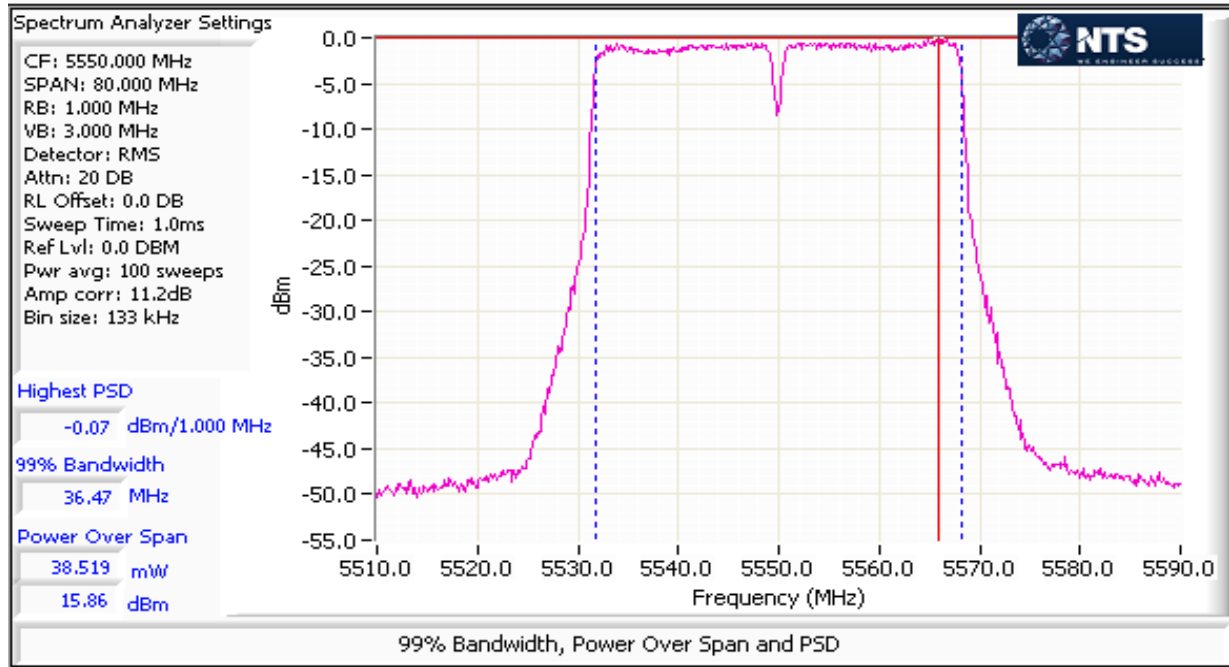

Client: Vivint Wireless	Job Number: J96161
Model: SR1530 (4x4 5GHz 802.11 AP)	T-Log Number: T97162
Contact: Venkat Kalkunte	Project Manager: Irene Rademacher
Standard: FCC 15.B / 15.407 (New Rules)	Project Coordinator: -
	Class: N/A

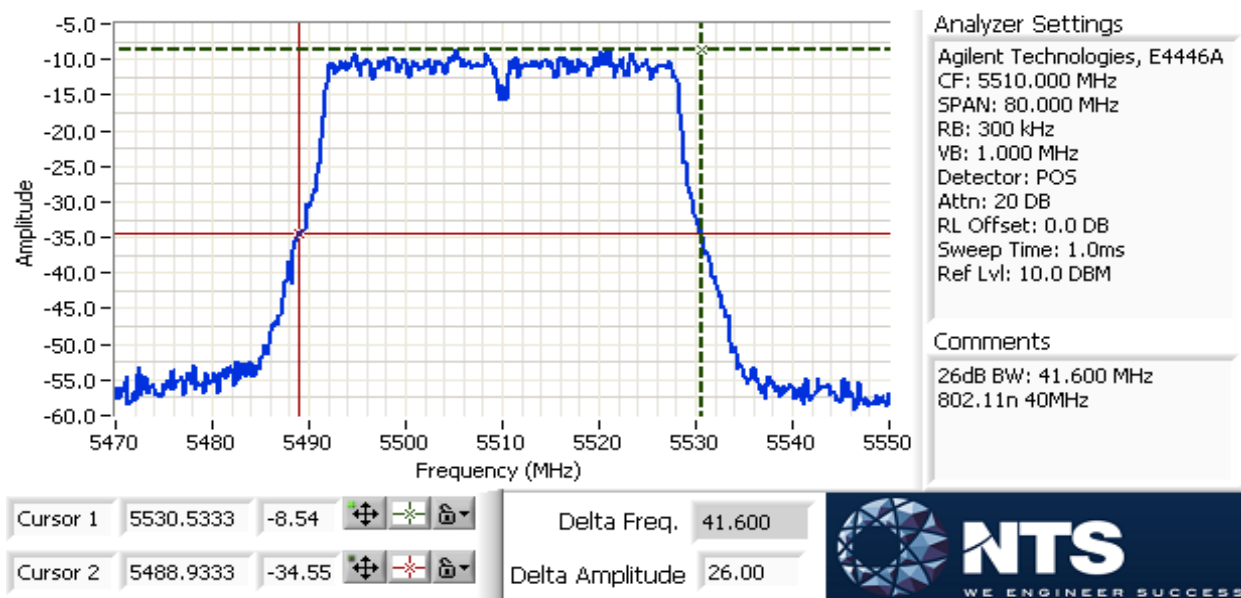
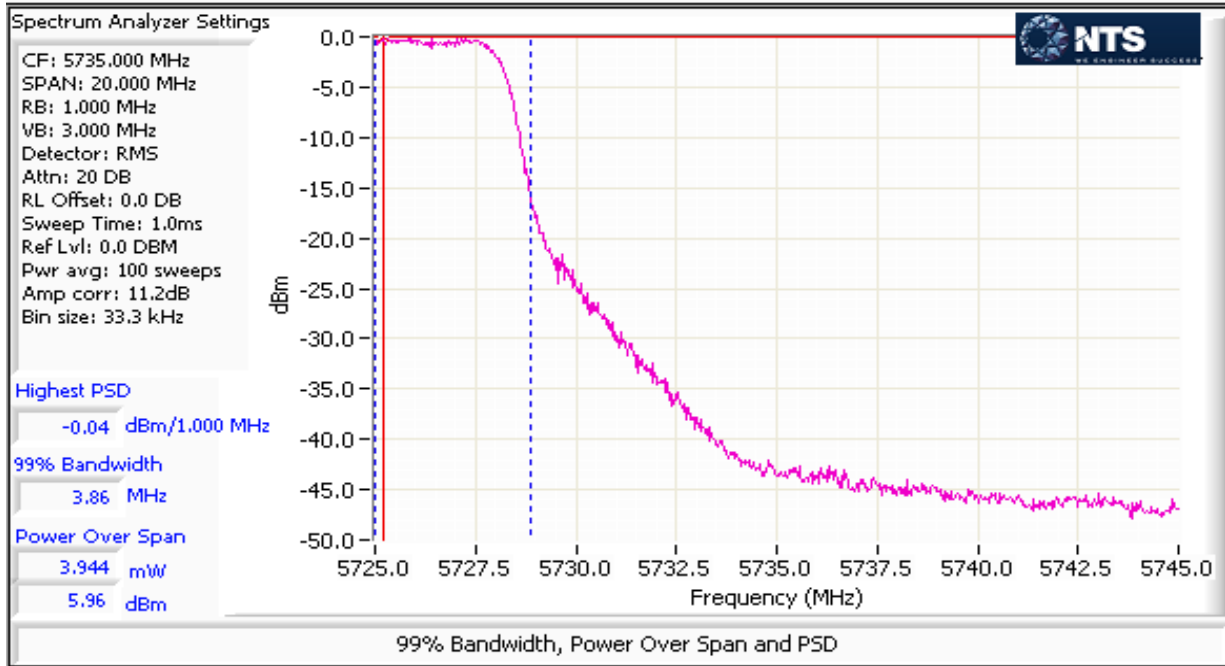



EMC Test Data

Client: Vivint Wireless	Job Number: J96161
Model: SR1530 (4x4 5GHz 802.11 AP)	T-Log Number: T97162
	Project Manager: Irene Rademacher
Contact: Venkat Kalkunte	Project Coordinator: -
Standard: FCC 15.B / 15.407 (New Rules)	Class: N/A

MIMO Device - 5725-5850 MHz Band - FCC

Mode: n40

Max EIRP (mW): 2728.5

Frequency (MHz)	Chain	Software Setting	26dB BW (MHz)	Duty Cycle %	Power dBm	Total Power ¹ mW	dBm	FCC Limit dBm	Max Power (W)	Result
5755	0	16		94.3	16.1	182.3	22.6	27.5	0.385	Pass
	1				15.7					
	2				16.9					
	3				16.6					
5795	0	19		94.3	19.3	384.5	25.8	27.5		
	1				18.8					
	2				19.9					
	3				20.2					

MIMO Device 5725-5850 PSD - FCC

Mode: n40

Frequency (MHz)	Chain	Software Setting	99% BW (MHz)	Duty Cycle %	PSD dBm/MHz	Total PSD ¹ mW/MHz	dBm/MHz	FCC Limit dBm/500kHz	IC Limit	Result
5755	0	16	36.47	94.3	-0.04	4.5	6.5	27.5	-	Pass
	1				-0.5					
	2				0.9					
	3				0.5					
5795	0	19	36.47	94.3	3.2	9.3	9.7	27.5	-	Pass
	1				2.6					
	2				3.8					
	3				3.9					

Client: Vivint Wireless	Job Number: J96161
Model: SR1530 (4x4 5GHz 802.11 AP)	T-Log Number: T97162
	Project Manager: Irene Rademacher
Contact: Venkat Kalkunte	Project Coordinator: -
Standard: FCC 15.B / 15.407 (New Rules)	Class: N/A

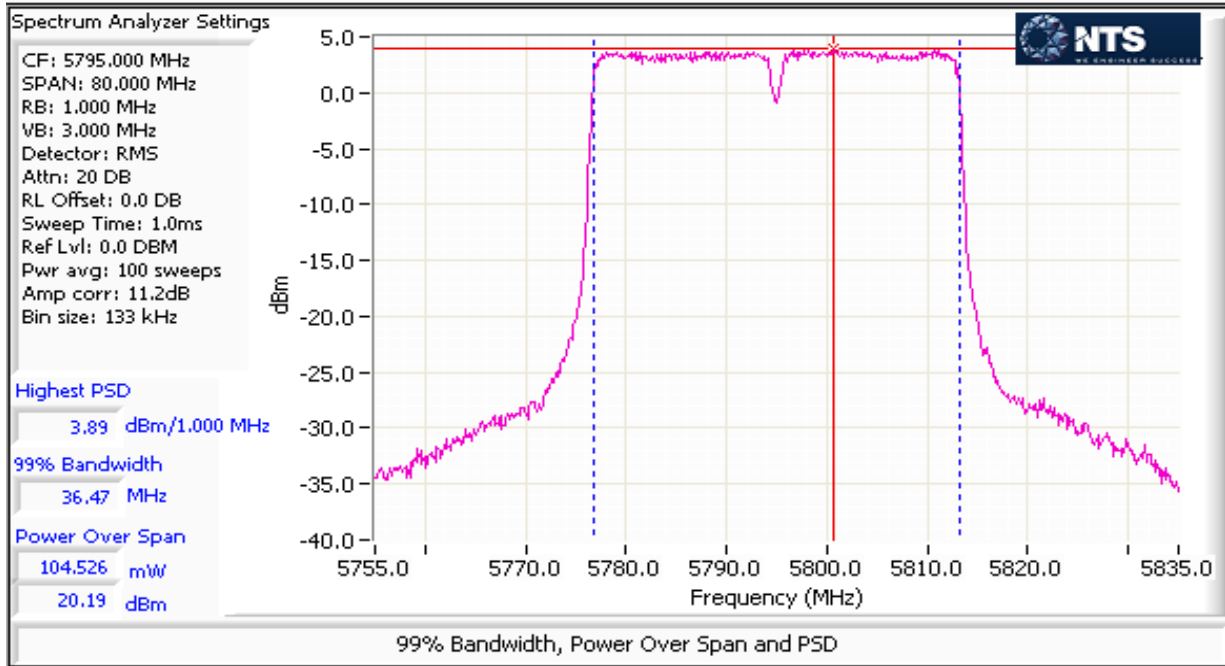

Client: Vivint Wireless	Job Number: J96161
Model: SR1530 (4x4 5GHz 802.11 AP)	T-Log Number: T97162
	Project Manager: Irene Rademacher
Contact: Venkat Kalkunte	Project Coordinator: -
Standard: FCC 15.B / 15.407 (New Rules)	Class: N/A

Run #2: Bandwidth Measurements

Date of Test: 3/10/2015 0:00 Config. Used: 1
 Test Engineer: Joseph Cadigal Config Change: none
 Test Location: FT Lab #4B EUT Voltage: POE

Mode: HT40
5725-5850MHz band (UNII3)
Testing performed on port: 0

Power Setting	Frequency (MHz)	Bandwidth (MHz)		RBW Setting (MHz)	
		6dB	99%	6dB	99%
16	5755	36.53	36.47	0.1	1
19	5795	36.27	36.47	0.1	1

Note 1: 6dB BW: RBW=100kHz, VBW ≥ 3*RBW, peak detector, max hold, auto sweep time.
 99% BW: RBW=1-5% of of 99%BW, VBW ≥ 3*RBW, peak detector, max hold, auto sweep time.

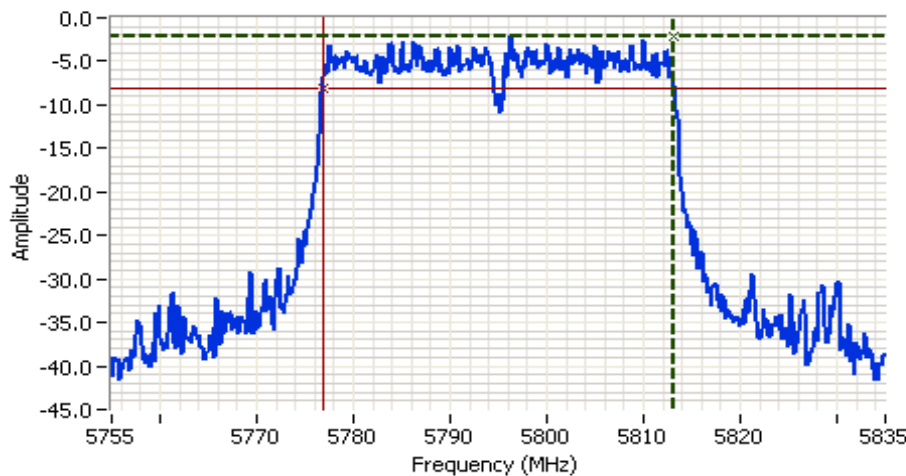

Analyzer Settings
 Agilent Technologies, E4446A
 CF: 5795.000 MHz
 SPAN: 80.000 MHz
 RB: 300 kHz
 VB: 1.000 MHz
 Detector: POS
 Attn: 20 DB
 RL Offset: 0.0 DB
 Sweep Time: 1.0ms
 Ref Lvl: 0.0 DBM

Comments
 6dB BW: 36.267 MHz
 802.11n 40MHz

Cursor 1: 5813.1333 -2.13 [Icons]
 Cursor 2: 5776.8667 -8.13 [Icons]

Delta Freq. 36.267
 Delta Amplitude 6.00



EMC Test Data

Client: Vivint Wireless	Job Number: J96161
Model: SR1530 (4x4 5GHz 802.11 AP)	T-Log Number: T97162
	Project Manager: Irene Rademacher
Contact: Venkat Kalkunte	Project Coordinator: -
Standard: FCC 15.B / 15.407 (New Rules)	Class: N/A

RSS-210 (LELAN) and FCC 15.407(UNII) Antenna Port Measurements Power, PSD, Peak Excursion, Bandwidth and Spurious Emissions

Test Specific Details

Objective: The objective of this test session is to perform final qualification testing of the EUT with respect to the specification listed above.

Summary of Results

Run #	Test Performed	Limit	Pass / Fail	Result / Margin
1	Power, 5150 - 5250MHz	15.407(a) (1) (i)	Pass	ac80: 18.5dBm (0.070W)
1	PSD, 5150 - 5250MHz	15.407(a) (1) (i)	Pass	ac80: 0.8dBm/MHz
1	Power, 5150 - 5250MHz	15.407(a) (1) (i)	Pass	n40: 12.2mW >30deg above horizon
1	Power, 5250 - 5350MHz	15.407(a) (2)	Pass	ac80: 21.4dBm (0.138W)
1	PSD, 5250 - 5350MHz	15.407(a) (2)	Pass	ac80: 4.0dBm/MHz
1	Max EIRP 5250 - 5350MHz	TPC required if EIRP ≥ 500mW (27dBm). EIRP ≥ 200mW (23dBm) DFS threshold = -64dBm.		EIRP = 0.775W (28.9dBm)
1	Power, 5470 - 5725MHz	15.407(a) (2)	Pass	ac80: 21.8dBm (0.152W)
1	PSD, 5470 - 5725MHz	15.407(a) (2)	Pass	ac80: 4.6dBm/MHz
1	Max EIRP 5470 - 5725MHz	TPC required if EIRP ≥ 500mW (27dBm). EIRP ≥ 200mW (23dBm) DFS threshold		EIRP = 0.962W (29.8dBm)
1	Power, 5725 - 5850MHz	15.407(a) (3)	Pass	ac80: 18.8dBm (0.085W)
1	PSD, 5725 - 5850MHz	15.407(a) (3)	Pass	ac80: 1.1dBm/MHz
1	26dB Bandwidth	15.407 (Information only)	N/A	ac80: 74.0MHz
2	Minimum 6dB Bandwidth for UNII3 band	15.407(e)	Pass	ac80: 75.0MHz



EMC Test Data

Client: Vivint Wireless	Job Number: J96161
Model: SR1530 (4x4 5GHz 802.11 AP)	T-Log Number: T97162
	Project Manager: Irene Rademacher
Contact: Venkat Kalkunte	Project Coordinator: -
Standard: FCC 15.B / 15.407 (New Rules)	Class: N/A

General Test Configuration

When measuring the conducted emissions from the EUT's antenna port, the antenna port of the EUT was connected to the spectrum analyzer or power meter via a suitable attenuator to prevent overloading the measurement system. All measurements are corrected to allow for the external attenuators and cables used.

Ambient Conditions:

Temperature: 25 °C
 Rel. Humidity: 40 %

Modifications Made During Testing

No modifications were made to the EUT during testing

Deviations From The Standard

No deviations were made from the requirements of the standard.

Procedure Comments:

Measurements performed in accordance with FCC KDB 789033 D01 v01r03, dated April 8, 2013

Mode	Data Rate	Duty Cycle (x)	Constant DC?	T (ms)	Pwr Cor Factor*	Lin Volt Cor Factor**	Min VBW for FS (Hz)
ac80	MCS8	92.1%	yes	0.58	0.36	0.72	1724

Sample Notes

Sample S/N: Prototype

Driver: -



EMC Test Data

Client: Vivint Wireless	Job Number: J96161
Model: SR1530 (4x4 5GHz 802.11 AP)	T-Log Number: T97162
	Project Manager: Irene Rademacher
Contact: Venkat Kalkunte	Project Coordinator: -
Standard: FCC 15.B / 15.407 (New Rules)	Class: N/A

Antenna Gain Information

Freq	Antenna Gain (dBi) / Chain				BF	MultiChain Legacy	CDD	Sectorized / Xpol	Dir G (PWR)	Dir G (PSD)
	1	2	3	4						
5150-5250	4	4	4	4	Yes	No	Yes	No	7.0	7.0
5250-5350	4.5	4.5	4.5	4.5	Yes	No	Yes	No	7.5	7.5
5470-5725	5	5	5	5	Yes	No	Yes	No	8.0	8.0
5725-5850	5.5	5.5	5.5	5.5	Yes	No	Yes	No	8.5	8.5

For devices that support CDD modes

Min # of spatial streams: 2 MCS8 is the lowest rate supported
 Max # of spatial streams: 4

Notes:	BF = beamforming mode supported, Multichain Legacy = 802.11 legacy data rates supported for multichain transmissions, CDD = Cyclic Delay Diversity (or Cyclic Shift Diversity) modes supported, Sectorized / Xpol = antennas are sectorized or cross polarized.
Notes:	Dir G (PWR) = total gain (Gant + Array Gain) for power calculations; GA (PSD) = total gain for PSD calculations based on FCC KDB 662911. Depending on the modes supported, the Array Gain value for power could be different from the PSD value.
Notes:	Array gain for power/psd calculated per DKB 662911 D01, v01r02. Spatial Multiplexing with Nant=4, Nss=2, for worse case condition. Array gain = $10 \cdot \log(4/2) = 3\text{dB}$.

Note:

1. Antenna port number defined

Port JE09 -Test port 0 ; Port JE10 -Test port 1 ; Port JE11 -Test port 2 ; Port JE12 -Test port 3

2. All the measurements measured at the end of the internal cable, not the output on the PCB board.

Tx Chain: 4x4
 Mode: AC80
 Data Rate: MCS 8
 Packet Size: 1000



EMC Test Data

Client: Vivint Wireless	Job Number: J96161
Model: SR1530 (4x4 5GHz 802.11 AP)	T-Log Number: T97162
	Project Manager: Irene Rademacher
Contact: Venkat Kalkunte	Project Coordinator: -
Standard: FCC 15.B / 15.407 (New Rules)	Class: N/A

MIMO Device - 5150-5250 MHz Band - FCC

Mode: ac80

Max EIRP (mW): 351.7

Frequency (MHz)	Chain	Software Setting	26dB BW (MHz)	Duty Cycle %	Power ¹ dBm	Total Power mW	Total Power dBm	FCC Limit dBm	Max Power (W)	Result
5210	0	14	81.50	92.1	12.2	70.0	18.5	29.0	0.070	Pass
	1				12.1					
	2				12.6					
	3				11.4					

5150-5250 PSD - FCC

Mode: ac80

Frequency (MHz)	Chain	Software Setting	99% BW (MHz)	Duty Cycle %	PSD dBm/MHz	Total PSD ¹ mW/MHz	Total PSD ¹ dBm/MHz	FCC Limit dBm/MHz	IC Limit dBm/MHz	Result
5210	0	14	75.37	92.1	-5.3	1.2	0.8	16.0	-	Pass
	1				-6.0					
	2				-5.2					
	3				-5.8					



EMC Test Data

Client: Vivint Wireless	Job Number: J96161
Model: SR1530 (4x4 5GHz 802.11 AP)	T-Log Number: T97162
Contact: Venkat Kalkunte	Project Manager: Irene Rademacher
Standard: FCC 15.B / 15.407 (New Rules)	Project Coordinator: -
	Class: N/A

Outdoor master devices are limited to 125mW (21dBm), 30deg above the horizon for all mounting configurations

Mode: ac80

Max EIRP (mW): 12.2

Max Antenna gain 30deg above horizon: -7.57 dBi

Max EIRP (dBm): 10.9

Frequency (MHz)	Chain	Software Setting	26dB BW (MHz)	Duty Cycle %	Power ¹ dBm	Total Power		FCC Limit dBm (EIRP)	Max Power (W)	Result
						mW	dBm			
5210	0	14	81.5	92.1	12.2	70.0	18.5	21.0	0.070	Pass
	1				12.1					
	2				12.6					
	3				11.4					

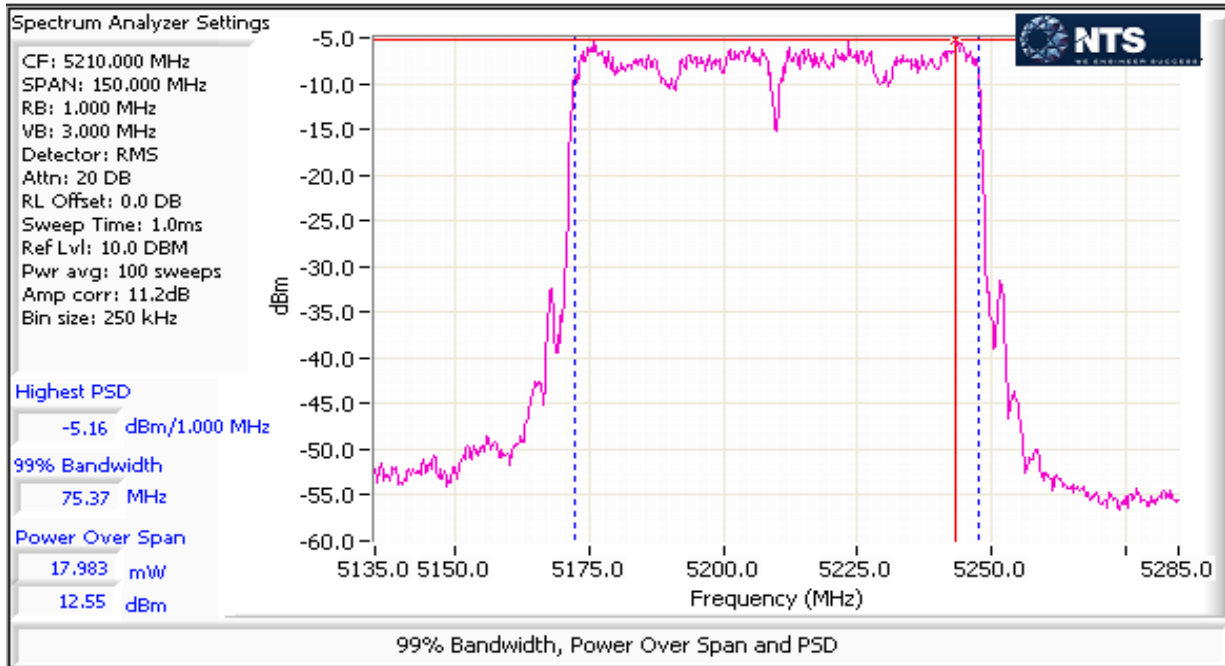



EMC Test Data

Client: Vivint Wireless	Job Number: J96161
Model: SR1530 (4x4 5GHz 802.11 AP)	T-Log Number: T97162
Contact: Venkat Kalkunte	Project Manager: Irene Rademacher
Standard: FCC 15.B / 15.407 (New Rules)	Project Coordinator: -
	Class: N/A

MIMO Device - 5250-5350 MHz Band - FCC

Mode: ac80

Max EIRP (mW): 775.1

Frequency (MHz)	Chain	Software Setting	26dB BW (MHz)	Duty Cycle %	Power dBm	Total Power ¹ mW	Total Power ¹ dBm	FCC Limit dBm	Max Power (W)	Result
5290	0	17	81.25	92.1	15.2	137.5	21.4	22.5	0.138	Pass
	1				15.1					
	2				15.3					
	3				14.4					

MIMO Device 5250-5350 PSD - FCC

Mode: ac80

Frequency (MHz)	Chain	Software Setting	99% BW (MHz)	Duty Cycle %	PSD dBm/MHz	Total PSD ¹ mW/MHz	Total PSD ¹ dBm/MHz	FCC Limit dBm/MHz	IC Limit dBm/MHz	Result
5290	0	17	75.62	92.1	-2.6	2.5	4.0	9.5	-	Pass
	1				-2.6					
	2				-2.1					
	3				-2.6					

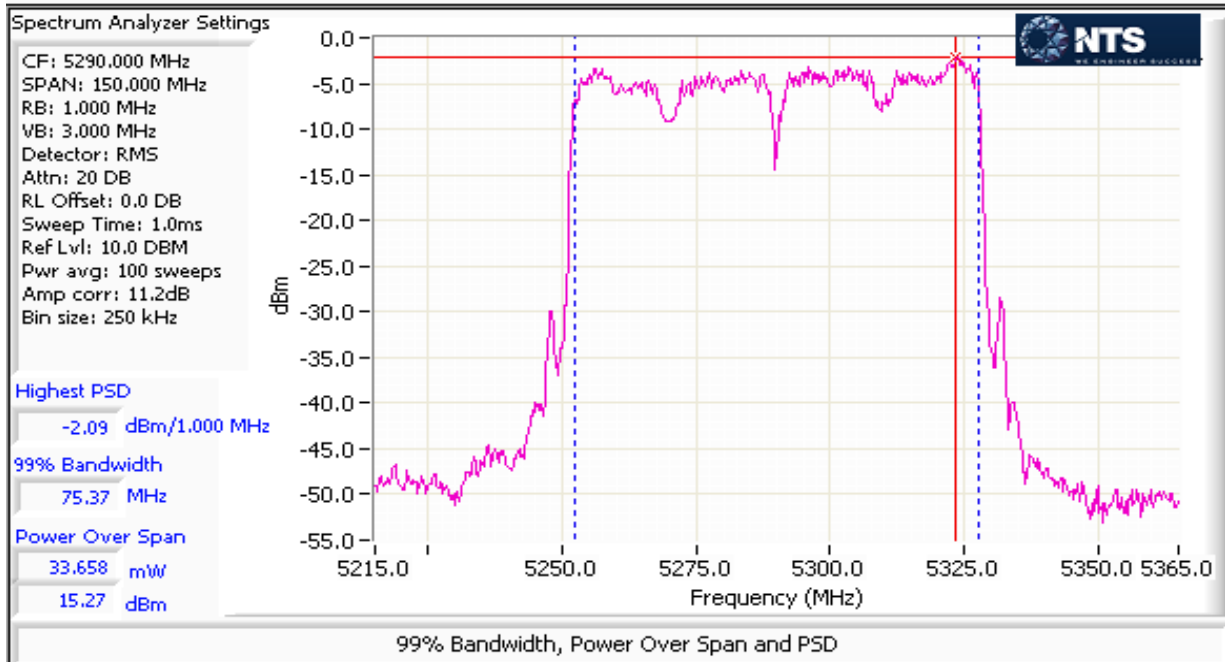



EMC Test Data

Client: Vivint Wireless	Job Number: J96161
Model: SR1530 (4x4 5GHz 802.11 AP)	T-Log Number: T97162
	Project Manager: Irene Rademacher
Contact: Venkat Kalkunte	Project Coordinator: -
Standard: FCC 15.B / 15.407 (New Rules)	Class: N/A

MIMO Device - 5470-5725 MHz Band - FCC

Mode: ac80

Max EIRP (mW): 962

Frequency (MHz)	Chain	Software Setting	26dB BW (MHz)	Duty Cycle %	Power dBm	Total Power ¹ mW	FCC Limit dBm	Max Power (W)	Result	
5530	0	14	81.25	92.1	11.4	63.4	18.0	0.152	Pass	
	1				12.0					
	2				12.5					
	3				10.5					
5610	0	17	81.50	92.1	14.5	130.0	21.1		22.0	Pass
	1				14.9					
	2				15.7					
	3				13.7					
802.11ac 80MHz UNII-2ext										
5690	0	18	74.00	92.1	15.3	152.1	21.8		22.0	Pass
	1				15.5					
	2				16.4					
	3				14.4					
UNII-3										
5690	0	18	4.50	92.1	2.1	7.3	8.6	15.5	Pass	
	1				2.3					
	2				3.1					
	3				1.4					



EMC Test Data

Client: Vivint Wireless	Job Number: J96161
Model: SR1530 (4x4 5GHz 802.11 AP)	T-Log Number: T97162
	Project Manager: Irene Rademacher
Contact: Venkat Kalkunte	Project Coordinator: -
Standard: FCC 15.B / 15.407 (New Rules)	Class: N/A

MIMO Device 5470-5725 PSD - FCC

Mode: ac80

Frequency (MHz)	Chain	Software Setting	99% BW (MHz)	Duty Cycle %	PSD dBm/MHz	Total PSD ¹		FCC Limit dBm/MHz	IC Limit dBm/MHz	Result
5530	0	14	75.37	92.1	-6.6	1.1	0.4	9.0	-	Pass
	1				-5.9					
	2				-5.3					
	3				-6.2					
5610	0	17	75.37	92	-3.0	2.4	3.8	9.0	-	Pass
	1				-2.8					
	2				-1.8					
	3				-2.6					

802.11ac 80MHz

UNII-2ext

5690	0	18	72.66	92.1	-1.9	2.9	4.6	9.0	-	Pass
	1				-2.2					
	2				-1.1					
	3				-2.1					

UNII-3

5690	0	18	3.76	92.1	-2.2	2.7	4.3	9.0	-	Pass
	1				-2.3					
	2				-1.9					
	3				-1.8					

Client: Vivint Wireless	Job Number: J96161
Model: SR1530 (4x4 5GHz 802.11 AP)	T-Log Number: T97162
Contact: Venkat Kalkunte	Project Manager: Irene Rademacher
Standard: FCC 15.B / 15.407 (New Rules)	Project Coordinator: -
	Class: N/A

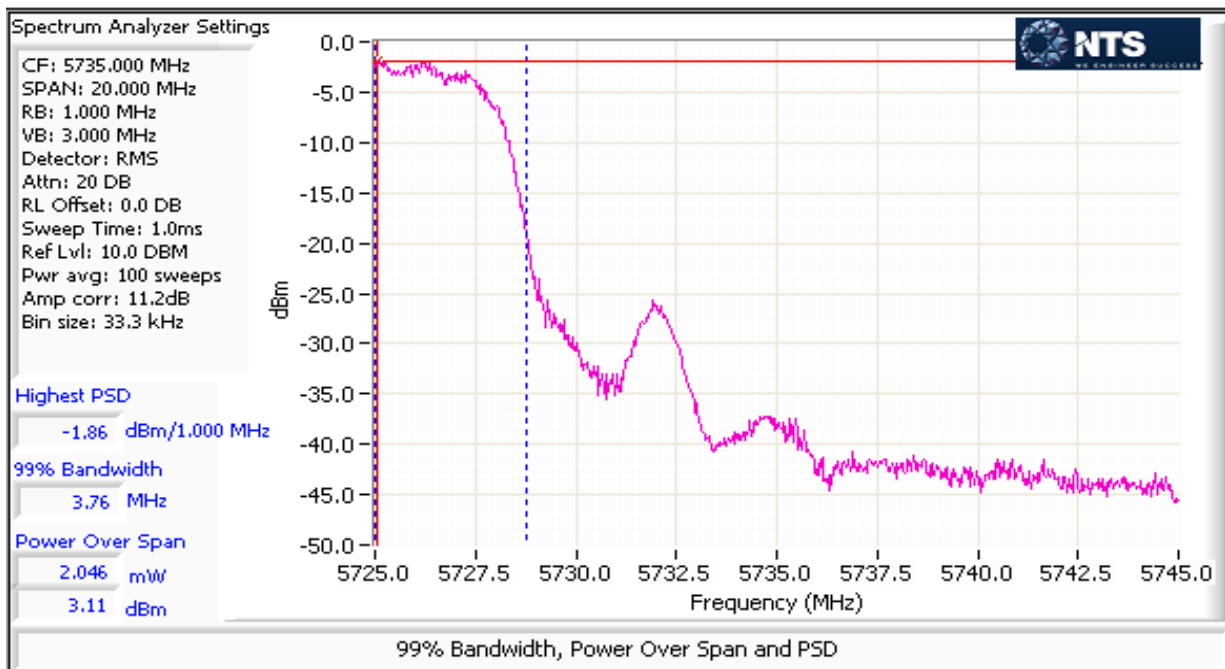
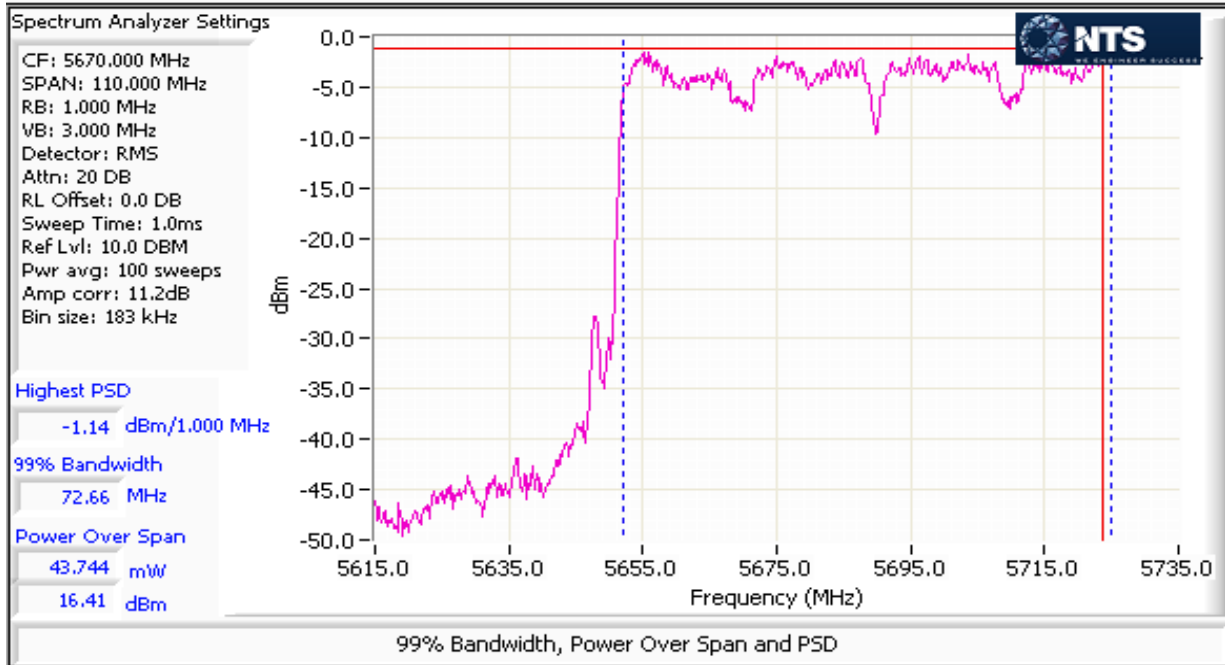

Client: Vivint Wireless	Job Number: J96161
Model: SR1530 (4x4 5GHz 802.11 AP)	T-Log Number: T97162
	Project Manager: Irene Rademacher
Contact: Venkat Kalkunte	Project Coordinator: -
Standard: FCC 15.B / 15.407 (New Rules)	Class: N/A

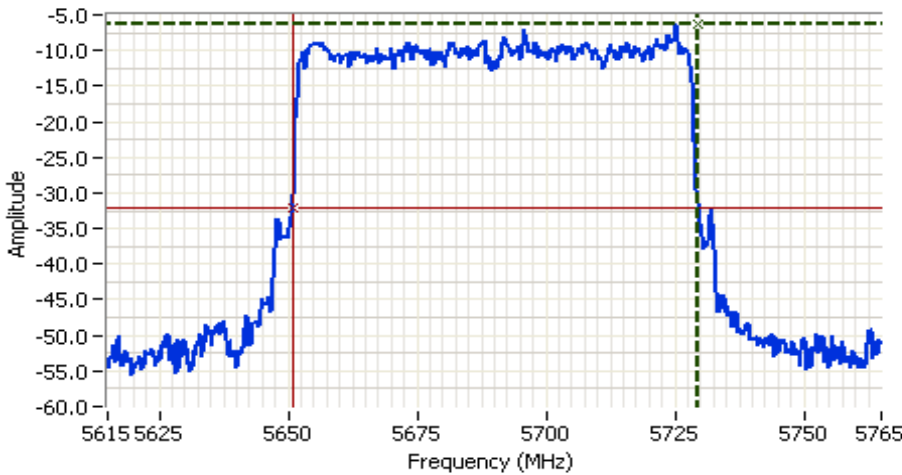

Analyzer Settings

Agilent Technologies, E4446A
 CF: 5690.000 MHz
 SPAN: 150.000 MHz
 RB: 300 kHz
 VB: 1.000 MHz
 Detector: POS
 Attn: 20 DB
 RL Offset: 0.0 DB
 Sweep Time: 1.0ms
 Ref Lvl: 10.0 DBM

Comments

26dB BW: 78.500 MHz
 UNII2-ext: 74MHz
 UNII3: 4.5MHz
 802.11ac 80MHz

Cursor 1 5729.5000 -6.20

Cursor 2 5651.0000 -32.20

Delta Freq. 78.500

Delta Amplitude 26.00



EMC Test Data

Client: Vivint Wireless	Job Number: J96161
Model: SR1530 (4x4 5GHz 802.11 AP)	T-Log Number: T97162
Contact: Venkat Kalkunte	Project Manager: Irene Rademacher
Standard: FCC 15.B / 15.407 (New Rules)	Project Coordinator: -
	Class: N/A

MIMO Device - 5725-5850 MHz Band - FCC

Mode: ac80

Max EIRP (mW): 606

Frequency (MHz)	Chain	Software Setting	26dB BW (MHz)	Duty Cycle %	Power dBm	Total Power ¹ mW	Total Power ¹ dBm	FCC Limit dBm	Max Power (W)	Result
5775	0	15		92.1	12.8	85.4	19.3	27.5	0.085	Pass
	1				12.5					
	2				13.9					
	3				12.4					

MIMO Device 5725-5850 PSD - FCC

Mode: ac80

Frequency (MHz)	Chain	Software Setting	99% BW (MHz)	Duty Cycle %	PSD dBm/MHz	Total PSD ¹ mW/MHz	Total PSD ¹ dBm/MHz	FCC Limit dBm/500kHz	IC Limit	Result
5775	0	15	75.62	92.1	-4.9	1.5	1.8	27.5	-	Pass
	1				-5.4					
	2				-4.0					
	3				-4.6					

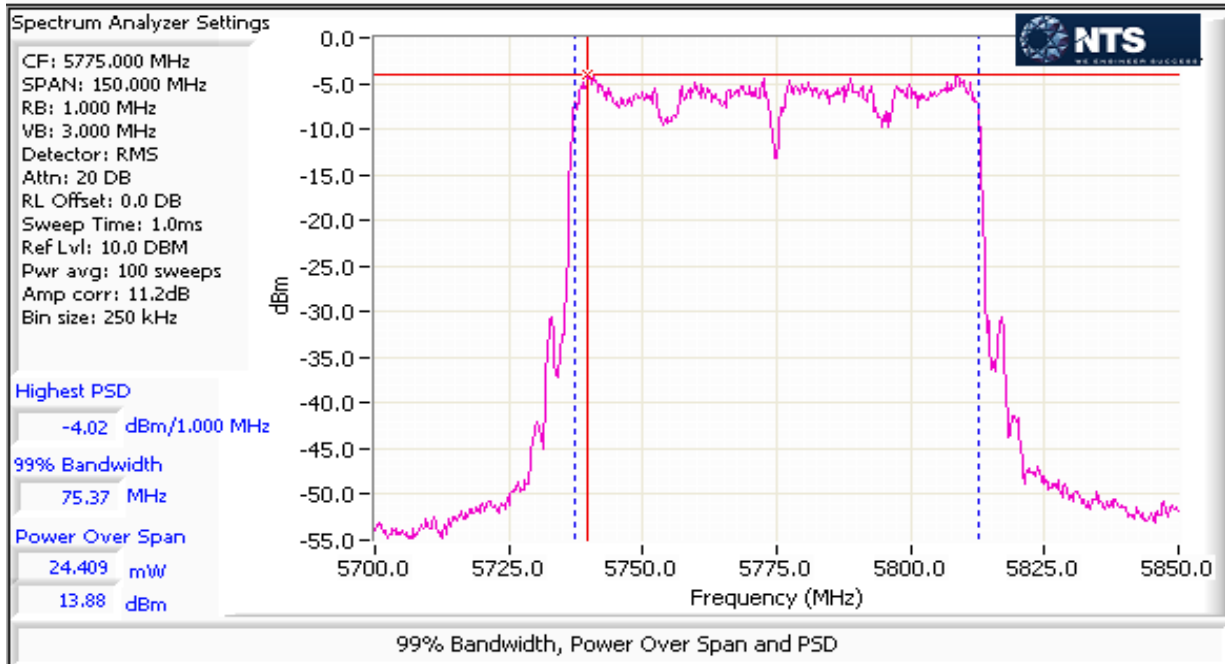

Client: Vivint Wireless	Job Number: J96161
Model: SR1530 (4x4 5GHz 802.11 AP)	T-Log Number: T97162
	Project Manager: Irene Rademacher
Contact: Venkat Kalkunte	Project Coordinator: -
Standard: FCC 15.B / 15.407 (New Rules)	Class: N/A

Run #2: Bandwidth Measurements

Date of Test: 3/11/2015 0:00 Config. Used: 1
 Test Engineer: Joseph Cadigal Config Change: none
 Test Location: FT Lab#4B EUT Voltage: POE

Mode: AC80
5725-5850MHz band (UNII3)
Testing performed on port: 0

Power Setting	Frequency (MHz)	Bandwidth (MHz)		RBW Setting (MHz)	
		6dB	99%	6dB	99%
15	5775	75.00	75.62	0.1	1

Note 1: 6dB BW: RBW=100kHz, VBW ≥ 3*RBW, peak detector, max hold, auto sweep time.
 99% BW: RBW=1.5% of of 99%BW, VBW ≥ 3*RBW, peak detector, max hold, auto sweep time.

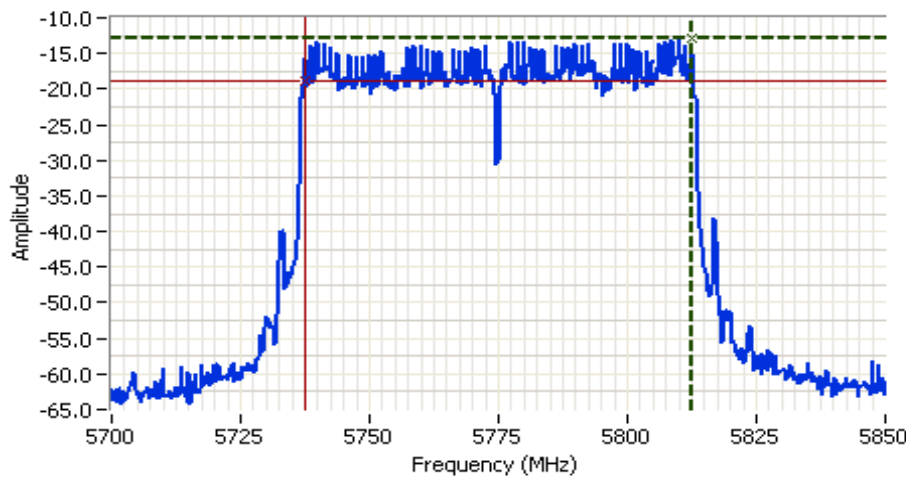

Analyzer Settings
 Agilent Technologies, E4446A
 CF: 5775.000 MHz
 SPAN: 150.000 MHz
 RB: 100 kHz
 VB: 300 kHz
 Detector: POS
 Attn: 20 DB
 RL Offset: 0.0 DB
 Sweep Time: 14.4ms
 Ref Lvl: 10.0 DBM

Comments
 6dB BW: 75.000 MHz
 802.11ac 80MHz

Cursor 1	5812.5000	-12.75	
Cursor 2	5737.5000	-18.75	

Delta Freq. 75.000
 Delta Amplitude 6.00





EMC Test Data

Client:	Vivint Wireless	Job Number:	J96091
Product	1520 (4x4 5GHz 802.11 Client)	T-Log Number:	T96173
		Project Manager:	Irene Rademacher
Contact:	Venkat Kalkunte	Project Coordinator:	-
Emissions Standard(s):	FCC 15.B / 15.407 (New Rules)	Class:	B
Immunity Standard(s):	-	Environment:	-

EMC Test Data

For The

Vivint Wireless

Product

1520 (4x4 5GHz 802.11 Client)

Date of Last Test: 3/11/2015



EMC Test Data

Client: Vivint Wireless	Job Number: J96091
Model: 1520 (4x4 5GHz 802.11 Client)	T-Log Number: T96173
	Project Manager: Irene Rademacher
Contact: Venkat Kalkunte	Project Coordinator: -
Standard: FCC 15.B / 15.407 (New Rules)	Class: B

Conducted Emissions

(Elliott Laboratories Fremont Facility, Semi-Anechoic Chamber)

Test Specific Details

Objective: The objective of this test session is to perform final qualification testing of the EUT with respect to the specification listed above.

Date of Test: 9/3/2014	Config. Used: 1
Test Engineer: Jack Liu	Config Change: None
Test Location: FT Chamber#4	EUT Voltage: POE

General Test Configuration

For tabletop equipment, the EUT was located on a non-conductive table inside the semi-anechoic chamber, 40 cm from a vertical coupling plane and 80cm from the LISN. Remote support equipment was located outside of the semi-anechoic chamber. Any cables running to remote support equipment were routed along the ground plane.

Ambient Conditions:

Temperature:	24 °C
Rel. Humidity:	40 %

Summary of Results

Run #	Test Performed	Limit	Result	Margin
1	CE, AC Power, 120V/60Hz	Class B	Pass	46.7 dBµV @ 14.772 MHz (-3.3 dB)

Modifications Made During Testing

No modifications were made to the EUT during testing

Deviations From The Standard

No deviations were made from the requirements of the standard.

NOTE: EUT configured to transmit n40 MCS8 channel to 151 @ power 18.

Client: Vivint Wireless	Job Number: J96091
Model: 1520 (4x4 5GHz 802.11 Client)	T-Log Number: T96173
Contact: Venkat Kalkunte	Project Manager: Irene Rademacher
Standard: FCC 15.B / 15.407 (New Rules)	Project Coordinator: -
	Class: B

Run #1: AC Power Port Conducted Emissions, 0.15 - 30MHz, 120V/60Hz

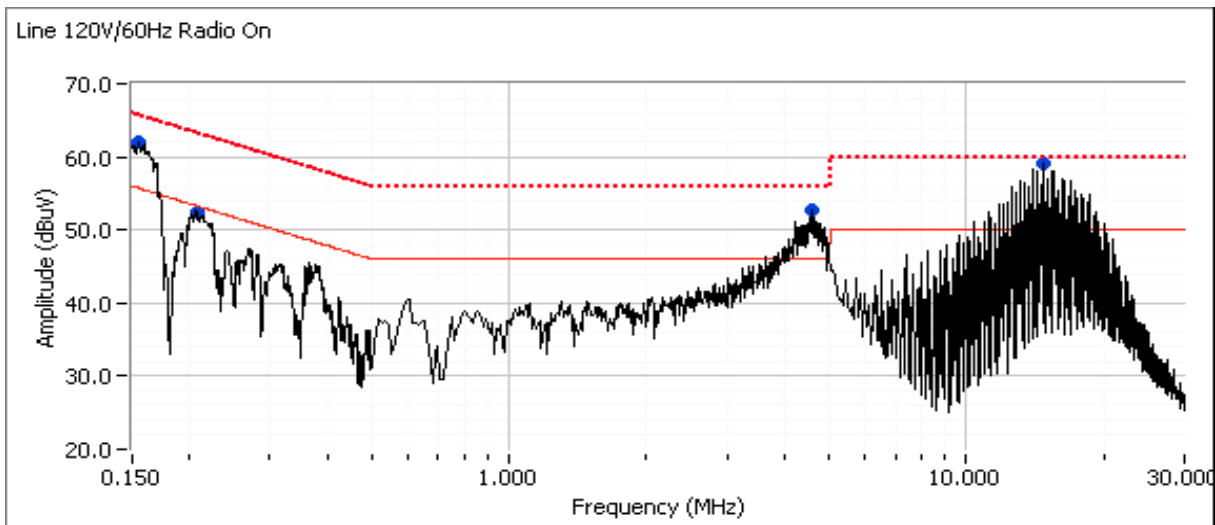
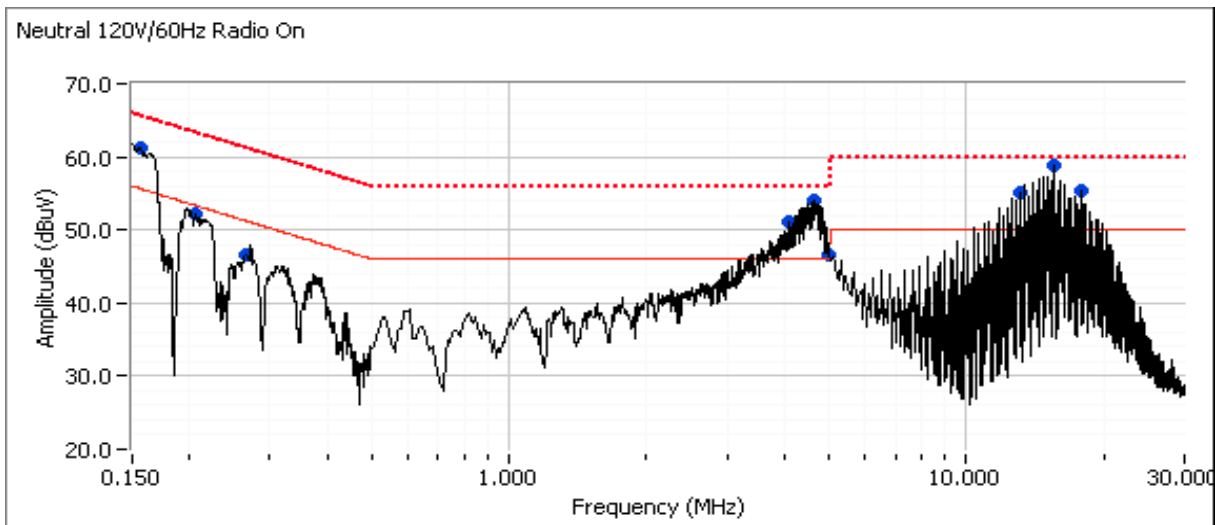



EMC Test Data

Client: Vivint Wireless	Job Number: J96091
Model: 1520 (4x4 5GHz 802.11 Client)	T-Log Number: T96173
	Project Manager: Irene Rademacher
Contact: Venkat Kalkunte	Project Coordinator: -
Standard: FCC 15.B / 15.407 (New Rules)	Class: B

Preliminary peak readings captured during pre-scan (peak readings vs. average limit)

Frequency MHz	Level dB μ V	AC Line	Class B		Detector QP/Ave	Comments
			Limit	Margin		
14.772	59.2	Line	50.0	9.2	Peak	
4.575	52.7	Line	46.0	6.7	Peak	
0.155	61.9	Line	55.7	6.2	Peak	
0.209	52.4	Line	53.3	-0.9	Peak	
0.205	52.2	Neutral	53.4	-1.2	Peak	
0.154	61.1	Neutral	55.7	5.4	Peak	
0.266	46.7	Neutral	51.3	-4.6	Peak	
4.638	54.0	Neutral	46.0	8.0	Peak	
4.106	51.2	Neutral	46.0	5.2	Peak	
15.558	58.8	Neutral	50.0	8.8	Peak	
13.101	55.2	Neutral	50.0	5.2	Peak	
17.740	55.4	Neutral	50.0	5.4	Peak	
4.988	46.6	Neutral	46.0	0.6	Peak	



EMC Test Data

Client: Vivint Wireless	Job Number: J96091
Model: 1520 (4x4 5GHz 802.11 Client)	T-Log Number: T96173
	Project Manager: Irene Rademacher
Contact: Venkat Kalkunte	Project Coordinator: -
Standard: FCC 15.B / 15.407 (New Rules)	Class: B

Final quasi-peak and average readings

Frequency MHz	Level dB μ V	AC Line	Class B		Detector QP/Ave	Comments
			Limit	Margin		
14.772	46.7	Line	50.0	-3.3	AVG	AVG (0.10s)
4.638	42.2	Neutral	46.0	-3.8	AVG	AVG (0.10s)
15.558	45.7	Neutral	50.0	-4.3	AVG	AVG (0.10s)
13.101	44.1	Neutral	50.0	-5.9	AVG	AVG (0.10s)
0.155	59.5	Line	65.7	-6.2	QP	QP (1.00s)
4.638	49.5	Neutral	56.0	-6.5	QP	QP (1.00s)
0.154	58.9	Neutral	65.8	-6.9	QP	QP (1.00s)
17.740	42.7	Neutral	50.0	-7.3	AVG	AVG (0.10s)
4.575	38.2	Line	46.0	-7.8	AVG	AVG (0.10s)
4.106	37.7	Neutral	46.0	-8.3	AVG	AVG (0.10s)
4.575	47.2	Line	56.0	-8.8	QP	QP (1.00s)
4.988	36.7	Neutral	46.0	-9.3	AVG	AVG (0.10s)
14.772	50.5	Line	60.0	-9.5	QP	QP (1.00s)
4.106	45.6	Neutral	56.0	-10.4	QP	QP (1.00s)
15.558	49.6	Neutral	60.0	-10.4	QP	QP (1.00s)
4.988	44.5	Neutral	56.0	-11.5	QP	QP (1.00s)
13.101	47.7	Neutral	60.0	-12.3	QP	QP (1.00s)
0.155	43.1	Line	55.7	-12.6	AVG	AVG (0.10s)
0.209	50.3	Line	63.2	-12.9	QP	QP (1.00s)
17.740	47.1	Neutral	60.0	-12.9	QP	QP (1.00s)
0.205	49.8	Neutral	63.4	-13.6	QP	QP (1.00s)
0.154	41.2	Neutral	55.8	-14.6	AVG	AVG (0.10s)
0.266	43.5	Neutral	61.2	-17.7	QP	QP (1.00s)
0.209	35.0	Line	53.2	-18.2	AVG	AVG (0.10s)
0.205	32.3	Neutral	53.4	-21.1	AVG	AVG (0.10s)
0.266	29.4	Neutral	51.2	-21.8	AVG	AVG (0.10s)

End of Report

This page is intentionally blank and marks the last page of this test report.