

EMC Test Report

Application for Grant of Equipment Authorization

FCC Part 15, Subpart E

Model: SR1430

FCC ID: 2AAAS-AP02

APPLICANT: Vivint Wireless
3945 Freedom Circle, Suite 150
Santa Clara, CA 95054

TEST SITE(S): National Technical Systems - Silicon Valley
41039 Boyce Road.
Fremont, CA. 94538-2435

IC SITE REGISTRATION #: 2845B-3; 2845B-4, 2845B-5, 2845B-7

REPORT DATE: November 7, 2014

REISSUE DATE: November 21, 2014

FINAL TEST DATES: August 5, 20, September 29, October 8, 9, 10,
13, 14, 15, 17 and November 4, 2014

TOTAL NUMBER OF PAGES: 70

PROGRAM MGR /
TECHNICAL REVIEWER:

QUALITY ASSURANCE DELEGATE /
FINAL REPORT PREPARER:

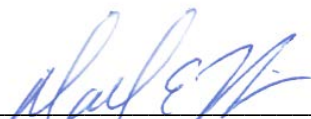

Mark E Hill
Staff Engineer



David Guidotti
Senior Technical Writer



National Technical Systems - Silicon Valley is accredited by the A2LA, certificate number 0214.26, to perform the test(s) listed in this report, except where noted otherwise. This report and the information contained herein represent the results of testing test articles identified and selected by the client performed to specifications and/or procedures selected by the client. National Technical Systems (NTS) makes no representations, expressed or implied, that such testing is adequate (or inadequate) to demonstrate efficiency, performance, reliability, or any other characteristic of the articles being tested, or similar products. This report should not be relied upon as an endorsement or certification by NTS of the equipment tested, nor does it represent any statement whatsoever as to its merchantability or fitness of the test article, or similar products, for a particular purpose. This report shall not be reproduced except in full



REVISION HISTORY

Rev#	Date	Comments	Modified By
-	November 7, 2014	First release	
1.0	November 21, 2014	Clarified operating conditions during testing	MEH

TABLE OF CONTENTS

REVISION HISTORY	2
TABLE OF CONTENTS	3
SCOPE.....	4
OBJECTIVE	4
STATEMENT OF COMPLIANCE.....	5
DEVIATIONS FROM THE STANDARDS.....	5
TEST RESULTS SUMMARY	6
UNII / LELAN DEVICES	6
GENERAL REQUIREMENTS APPLICABLE TO ALL BANDS.....	8
MEASUREMENT UNCERTAINTIES.....	9
EQUIPMENT UNDER TEST (EUT) DETAILS.....	10
GENERAL.....	10
OTHER EUT DETAILS.....	10
ANTENNA SYSTEM	10
ENCLOSURE.....	10
MODIFICATIONS.....	10
SUPPORT EQUIPMENT.....	11
EUT INTERFACE PORTS	11
EUT OPERATION	11
TEST SITE.....	12
GENERAL INFORMATION.....	12
CONDUCTED EMISSIONS CONSIDERATIONS	12
RADIATED EMISSIONS CONSIDERATIONS	12
MEASUREMENT INSTRUMENTATION	13
RECEIVER SYSTEM	13
INSTRUMENT CONTROL COMPUTER	13
LINE IMPEDANCE STABILIZATION NETWORK (LISN).....	13
FILTERS/ATTENUATORS	14
ANTENNAS.....	14
ANTENNA MAST AND EQUIPMENT TURNTABLE.....	14
INSTRUMENT CALIBRATION.....	14
TEST PROCEDURES	15
EUT AND CABLE PLACEMENT	15
CONDUCTED EMISSIONS.....	15
RADIATED EMISSIONS	16
CONDUCTED EMISSIONS FROM ANTENNA PORT	19
BANDWIDTH MEASUREMENTS	19
SPECIFICATION LIMITS AND SAMPLE CALCULATIONS	20
CONDUCTED EMISSIONS SPECIFICATION LIMITS: FCC 15.207; FCC 15.107(A), RSS GEN	20
GENERAL TRANSMITTER RADIATED EMISSIONS SPECIFICATION LIMITS	21
RECEIVER RADIATED SPURIOUS EMISSIONS SPECIFICATION LIMITS	21
FCC 15.407 (A) OUTPUT POWER LIMITS.....	21
OUTPUT POWER LIMITS –LELAN DEVICES.....	22
SPURIOUS EMISSIONS LIMITS –UNII AND LELAN DEVICES	22
SAMPLE CALCULATIONS - CONDUCTED EMISSIONS	22
SAMPLE CALCULATIONS - RADIATED EMISSIONS.....	23
SAMPLE CALCULATIONS - FIELD STRENGTH TO EIRP CONVERSION.....	24
APPENDIX A TEST EQUIPMENT CALIBRATION DATA	25
APPENDIX B TEST DATA	26
END OF REPORT	70

SCOPE

An electromagnetic emissions test has been performed on the Vivint Wireless model SR1430, pursuant to the following rules:

FCC Part 15, Subpart E requirements for UNII Devices

Conducted and radiated emissions data has been collected, reduced, and analyzed within this report in accordance with measurement guidelines set forth in the following reference standards and as outlined in National Technical Systems - Silicon Valley test procedures:

ANSI C63.10-2009

FCC General UNII Test Procedures KDB789033

The intentional radiator above has been tested in a simulated typical installation to demonstrate compliance with the relevant Industry Canada performance and procedural standards.

Final system data was gathered in a mode that tended to maximize emissions by varying orientation of EUT, orientation of power and I/O cabling, antenna search height, and antenna polarization.

Every practical effort was made to perform an impartial test using appropriate test equipment of known calibration. All pertinent factors have been applied to reach the determination of compliance.

OBJECTIVE

The primary objective of the manufacturer is compliance with the regulations outlined in the previous section.

Prior to marketing in the USA, all unlicensed transmitters and transceivers require certification. Receive-only devices operating between 30 MHz and 960 MHz are subject to either certification or a manufacturer's declaration of conformity, with all other receive-only devices exempt from the technical requirements.

Certification is a procedure where the manufacturer submits test data and technical information to a certification body and receives a certificate or grant of equipment authorization upon successful completion of the certification body's review of the submitted documents. Once the equipment authorization has been obtained, the label indicating compliance must be attached to all identical units, which are subsequently manufactured.

Maintenance of compliance is the responsibility of the manufacturer. Any modification of the product which may result in increased emissions should be checked to ensure compliance has been maintained (i.e., printed circuit board layout changes, different line filter, different power supply, harnessing or I/O cable changes, etc.).

STATEMENT OF COMPLIANCE

The tested sample of Vivint Wireless model SR1430 complied with the requirements of the following regulations:

FCC Part 15, Subpart E requirements for UNII Devices

Maintenance of compliance is the responsibility of the manufacturer. Any modifications to the product should be assessed to determine their potential impact on the compliance status of the device with respect to the standards detailed in this test report.

The test results recorded herein are based on a single type test of Vivint Wireless model SR1430 and therefore apply only to the tested sample. The sample was selected and prepared by Venkat Kalkunte of Vivint Wireless.

DEVIATIONS FROM THE STANDARDS

No deviations were made from the published requirements listed in the scope of this report.

TEST RESULTS SUMMARY

UNII / LELAN DEVICES

Operation in the 5.25 – 5.35 GHz Band

Note: The device may be used outdoors, therefore the spectral density of spurious emissions in the 5.15 – 5.25 GHz band were limited to the -27dBm/MHz limit.

FCC Rule Part	RSS Rule Part	Description	Measured Value / Comments	Limit / Requirement	Result (margin)
15.407(a) (2)		26dB Bandwidth	43.3MHz	N/A – limits output power if < 20MHz	N/A
15.407(a) (2)	A9.2(2)	Output Power	n40: 19.3dBm (85.5mW) (Max eirp: 0.481W)	24 dBm / 250mW (eirp < 30dBm)	Complies
15.407(a) (2)	-	Power Spectral Density	n40: 3.1 dBm/MHz	11 dBm/MHz	Complies

Operation in the 5.47 – 5.725 GHz Band

FCC Rule Part	RSS Rule Part	Description	Measured Value / Comments	Limit / Requirement	Result (margin)
15.407(a) (2)		26dB Bandwidth	37.1MHz	N/A – limits output power if < 20MHz	N/A
15.407(a) (2)	A9.2(2)	Output Power	n40: 21.97dBm (157mW) (Max eirp: 0.992W)	24 dBm / 250mW (eirp < 30dBm)	Complies
15.407(a) (2)		Power Spectral Density	n40: 6.2 dBm/MHz	11 dBm/MHz	Complies
KDB 443999	A9	Non-operation in 5600 – 5650 MHz sub band	Device cannot operate in the 5600 – 5650 MHz band –refer to Operational Description		Complies

Requirements for all U-NII/LELAN bands

FCC Rule Part	RSS Rule Part	Description	Measured Value / Comments	Limit / Requirement	Result
15.407	A9.5a	Modulation	Digital Modulation is used	Digital modulation is required	Complies
15.407(b) (5) / 15.209	A9.3	Spurious Emissions	53.8 dB μ V/m @ 11018.0 MHz (-0.2 dB)	Refer to page 22	Complies
15.407(a)(6)	-	Peak Excursion Ratio	9.7dB	< 13dB	Complies
	A9.5 (3)	Channel Selection	Spurious emissions tested at outermost channels in each band	Device was tested on the top, bottom and center channels in each band	N/A
15			Measurements on three channels in each band		Complies
15.407 (c)	A9.5(4)	Operation in the absence of information to transmit	Operation is discontinued in the absence of information	Device shall automatically discontinue operation in the absence of information to transmit	Complies
15.407 (g)	A9.5 (5)	Frequency Stability	Frequency stability is better than 20ppm	Signal shall remain within the allocated band	Complies
15.407 (h1)	A9.4	Transmit Power Control	TCP mechanism is discussed in the Operational Description	The U-NII device shall have the capability to operate with a mean EIRP value lower than 24dBm (250mW)	Complies
15.407 (h2)	A9.4	Dynamic frequency Selection (device with radar detection)	Refer to separate test report, reference R96591	Threshold -62dBm (-64dBm if eirp > 200mW) Channel Availability Check > 60s Channel closing transmission time < 260ms Channel move time < 10s Non occupancy period > 30minutes	Complies

GENERAL REQUIREMENTS APPLICABLE TO ALL BANDS

FCC Rule Part	RSS Rule part	Description	Measured Value / Comments	Limit / Requirement	Result (margin)
15.203	-	RF Connector	Antenna is integral	Unique or integral antenna required	Complies
15.207	RSS GEN Table 4	AC Conducted Emissions	60.0 dB μ V @ 0.151 MHz (-5.9 dB)	Refer to page 20	Complies
15.109	RSS GEN 7.2.3 Table 1	Receiver spurious emissions	N/A – receiver tunes above 960MHz		
15.247 (b) (5) 15.407 (f)	RSS 102	RF Exposure Requirements	Refer to MPE calculations in separate exhibit	Refer to OET 65, FCC Part 1 and RSS 102	Complies

MEASUREMENT UNCERTAINTIES

ISO/IEC 17025 requires that an estimate of the measurement uncertainties associated with the emissions test results be included in the report. The measurement uncertainties given below are based on a 95% confidence level and were calculated in accordance with UKAS document LAB 34.

Measurement Type	Measurement Unit	Frequency Range	Expanded Uncertainty
RF power, conducted (power meter)	dBm	25 to 7000 MHz	± 0.52 dB
RF power, conducted (Spectrum analyzer)	dBm	25 to 7000 MHz	± 0.7 dB
Conducted emission of transmitter	dBm	25 to 26500 MHz	± 0.7 dB
Conducted emission of receiver	dBm	25 to 26500 MHz	± 0.7 dB
Radiated emission (substitution method)	dBm	25 to 26500 MHz	± 2.5 dB
Radiated emission (field strength)	dB μ V/m	25 to 1000 MHz	± 3.6 dB
		1000 to 40000 MHz	± 6.0 dB
Conducted Emissions (AC Power)	dB μ V	0.15 to 30 MHz	± 2.4 dB

EQUIPMENT UNDER TEST (EUT) DETAILS

GENERAL

The Vivint Wireless model SR1430 is a 5GHz 802.11 4x4 master device. The EUT would normally be pole or wall mounted. For testing, it was placed on a tabletop. The EUT is powered via POE connection.

The sample was received on August 20, 2014 and tested on August 5, 20, September 29, October 8, 9, 10, 13, 14, 15, 17 and November 4, 2014. The EUT consisted of the following component(s):

Company	Model	Description	Serial Number	FCC ID
Vivint Wireless	SR1430	5GHz 802.11 4x4 radio	-	2AAAS-AP02

OTHER EUT DETAILS

The following EUT details should be noted:

5GHz only (old FCC rules)

40MHz only, with MCS8 (2 spatial streams) minimum data rates

4x4 operation only

Non-point-to-point

Beamforming (2 pairs) supported

Antenna: ~5dBi Sector

Outdoor Use

Master Device

ANTENNA SYSTEM

The antenna system consists of 4 element panel antenna integral to the device. Note, during testing 5dB of attenuation was placed between the antenna port and the RF output of the radio, making the antenna gain ~5dBi per element. Refer to test data for specific gain information.

Antenna port measurements were performed at the end of the internal RF cables that connect the radio circuitry.

ENCLOSURE

The EUT enclosure is primarily constructed of plastic. It measures approximately 26 cm wide by 10 cm deep by 26 cm high.

MODIFICATIONS

No modifications were made to the EUT during the time the product was at NTS Silicon Valley.

SUPPORT EQUIPMENT

No local support equipment was used during testing.

The following equipment was used as remote support equipment for emissions testing:

Company	Model	Description	Serial Number	FCC ID
-	PSE802G	POE Injector	-	-
Acer	Aspire 5735	Laptop Computer	LXAU59X265903089 BE2000	-

EUT INTERFACE PORTS

The I/O cabling configuration during testing was as follows:

EUT

Port	Connected To	Cable(s)		
		Description	Shielded or Unshielded	Length(m)
POE	POE Injector	CAT5	Unshielded	
USB	Not Connected	-	-	-

Additional on Support Equipment

Port	Connected To	Cable(s)		
		Description	Shielded or Unshielded	Length(m)
POE Injector	Laptop	CAT5	Unshielded	

EUT OPERATION

During emissions testing the EUT was configured to continuously transmit at the noted channel and power level. All transmissions were 4Tx with beamforming active.

TEST SITE**GENERAL INFORMATION**

Final test measurements were taken at the test sites listed below. Pursuant to section 2.948 of the FCC's Rules and section 3.3 of RSP-100, construction, calibration, and equipment data has been filed with the Commission and with industry Canada.

Site	Designation / Registration Numbers		Location
	FCC	Canada	
Chamber 4	US0027	2845B-4	41039 Boyce Road Fremont, CA 94538-2435

ANSI C63.4 recommends that ambient noise at the test site be at least 6 dB below the allowable limits. Ambient levels are below this requirement. The test site(s) contain separate areas for radiated and conducted emissions testing. Considerable engineering effort has been expended to ensure that the facilities conform to all pertinent requirements of ANSI C63.4.

CONDUCTED EMISSIONS CONSIDERATIONS

Conducted emissions testing is performed in conformance with ANSI C63.10. Measurements are made with the EUT connected to the public power network through a nominal, standardized RF impedance, which is provided by a line impedance stabilization network, known as a LISN. A LISN is inserted in series with each current-carrying conductor in the EUT power cord.

RADIATED EMISSIONS CONSIDERATIONS

The FCC has determined that radiation measurements made in a shielded enclosure are not suitable for determining levels of radiated emissions. Radiated measurements are performed in an open field environment or in a semi-anechoic chamber. The test sites are maintained free of conductive objects within the CISPR defined elliptical area incorporated in ANSI C63.4 guidelines and meet the Normalized Site Attenuation (NSA) requirements of ANSI C63.4.

MEASUREMENT INSTRUMENTATION

RECEIVER SYSTEM

An EMI receiver as specified in CISPR 16-1-1 is used for emissions measurements. The receivers used can measure over the frequency range of 9 kHz up to 2000 MHz. These receivers allow both ease of measurement and high accuracy to be achieved. The receivers have Peak, Average, and CISPR (Quasi-peak) detectors built into their design so no external adapters are necessary. The receiver automatically sets the required bandwidth for the CISPR detector used during measurements. If the repetition frequency of the signal being measured is below 20Hz, peak measurements are made in lieu of Quasi-Peak measurements.

For measurements above the frequency range of the receivers, a spectrum analyzer is utilized because it provides visibility of the entire spectrum along with the precision and versatility required to support engineering analysis. Average measurements above 1000MHz are performed on the spectrum analyzer using the linear-average method with a resolution bandwidth of 1 MHz and a video bandwidth of 10 Hz, unless the signal is pulsed in which case the average (or video) bandwidth of the measuring instrument is reduced to onset of pulse desensitization and then increased.

INSTRUMENT CONTROL COMPUTER

The receivers utilize either a Rohde & Schwarz EZM Spectrum Monitor/Controller or contain an internal Spectrum Monitor/Controller to view and convert the receiver measurements to the field strength at an antenna or voltage developed at the LISN measurement port, which is then compared directly with the appropriate specification limit. This provides faster, more accurate readings by performing the conversions described under Sample Calculations within the Test Procedures section of this report. Results are printed in a graphic and/or tabular format, as appropriate. A personal computer is used to record all measurements made with the receivers.

The Spectrum Monitor provides a visual display of the signal being measured. In addition, the controller or a personal computer run automated data collection programs which control the receivers. This provides added accuracy since all site correction factors, such as cable loss and antenna factors are added automatically.

LINE IMPEDANCE STABILIZATION NETWORK (LISN)

Line conducted measurements utilize a fifty microhenry Line Impedance Stabilization Network as the monitoring point. The LISN used also contains a 250 uH CISPR adapter. This network provides for calibrated radio frequency noise measurements by the design of the internal low pass and high pass filters on the EUT and measurement ports, respectively.

FILTERS/ATTENUATORS

External filters and precision attenuators are often connected between the receiving antenna or LISN and the receiver. This eliminates saturation effects and non-linear operation due to high amplitude transient events.

ANTENNAS

A loop antenna is used below 30 MHz. For the measurement range 30 MHz to 1000 MHz either a combination of a biconical antenna and a log periodic or a bi-log antenna is used. Above 1000 MHz, horn antennas are used. The antenna calibration factors to convert the received voltage to an electric field strength are included with appropriate cable loss and amplifier gain factors to determine an overall site factor, which is then programmed into the test receivers or incorporated into the test software.

ANTENNA MAST AND EQUIPMENT TURNTABLE

The antennas used to measure the radiated electric field strength are mounted on a non-conductive antenna mast equipped with a motor-drive to vary the antenna height. Measurements below 30 MHz are made with the loop antenna at a fixed height of 1m above the ground plane.

ANSI C63.10 specifies that the test height above ground for table mounted devices shall be 80 centimeters. Floor mounted equipment shall be placed on the ground plane if the device is normally used on a conductive floor or separated from the ground plane by insulating material from 3 to 12 mm if the device is normally used on a non-conductive floor as specified in ANSI C63.4. During radiated measurements, the EUT is positioned on a motorized turntable in conformance with this requirement.

INSTRUMENT CALIBRATION

All test equipment is regularly checked to ensure that performance is maintained in accordance with the manufacturer's specifications. All antennas are calibrated at regular intervals with respect to tuned half-wave dipoles. An exhibit of this report contains the list of test equipment used and calibration information.

TEST PROCEDURES

EUT AND CABLE PLACEMENT

The regulations require that interconnecting cables be connected to the available ports of the unit and that the placement of the unit and the attached cables simulate the worst case orientation that can be expected from a typical installation, so far as practicable. To this end, the position of the unit and associated cabling is varied within the guidelines of ANSI C63.10, and the worst-case orientation is used for final measurements.

CONDUCTED EMISSIONS

Conducted emissions are measured at the plug end of the power cord supplied with the EUT. Excess power cord length is wrapped in a bundle between 30 and 40 centimeters in length near the center of the cord. Preliminary measurements are made to determine the highest amplitude emission relative to the specification limit for all the modes of operation. Placement of system components and varying of cable positions are performed in each mode. A final peak mode scan is then performed in the position and mode for which the highest emission was noted on all current carrying conductors of the power cord.

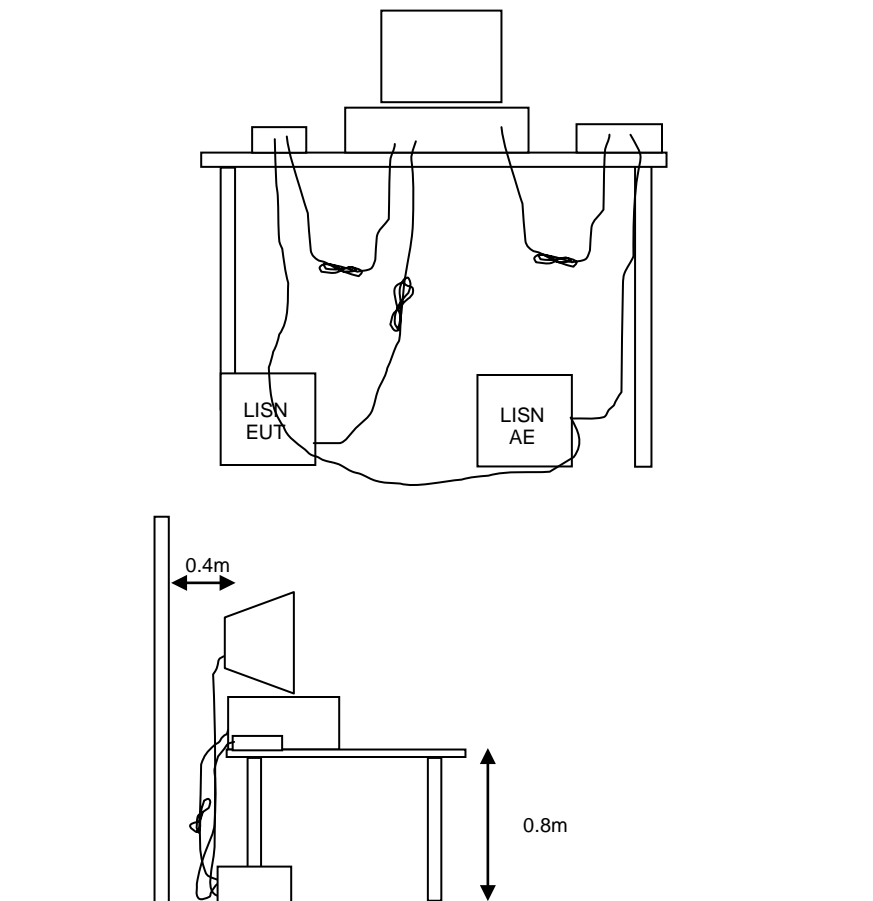

Figure 1 Typical Conducted Emissions Test Configuration

RADIATED EMISSIONS

A preliminary scan of the radiated emissions is performed in which all significant EUT frequencies are identified with the system in a nominal configuration. At least two scans are performed, one scan for each antenna polarization (horizontal and vertical; loop parallel and perpendicular to the EUT). During the preliminary scans, the EUT is rotated through 360°, the antenna height is varied (for measurements above 30 MHz) and cable positions are varied to determine the highest emission relative to the limit. Preliminary scans may be performed in a fully anechoic chamber for the purposes of identifying the frequencies of the highest emissions from the EUT.

A speaker is provided in the receiver to aid in discriminating between EUT and ambient emissions. Other methods used during the preliminary scan for EUT emissions involve scanning with near field magnetic loops, monitoring I/O cables with RF current clamps, and cycling power to the EUT.

Final maximization is a phase in which the highest amplitude emissions identified in the spectral search are viewed while the EUT azimuth angle is varied from 0 to 360 degrees relative to the receiving antenna. The azimuth, which results in the highest emission is then maintained while varying the antenna height from one to four meters (for measurements above 30 MHz, measurements below 30 MHz are made with the loop antenna at a fixed height of 1m). The result is the identification of the highest amplitude for each of the highest peaks. Each recorded level is corrected in the receiver using appropriate factors for cables, connectors, antennas, and preamplifier gain.

When testing above 18 GHz, the receive antenna is located at 1 meter from the EUT and the antenna height is restricted to a maximum of 2.5 meters.

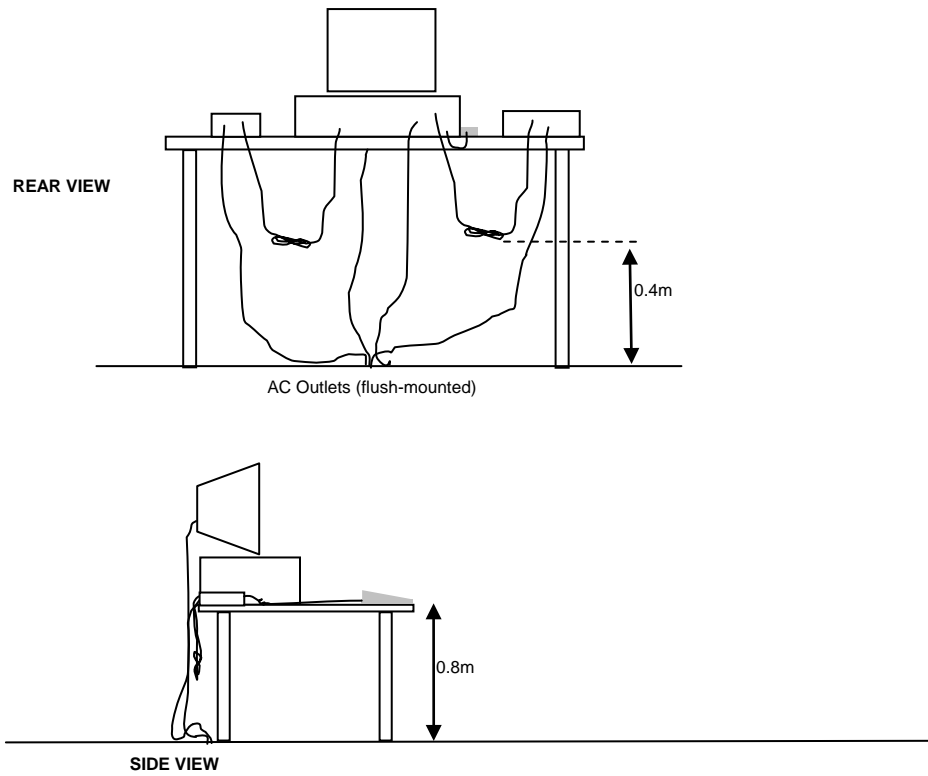

Typical Test Configuration for Radiated Field Strength Measurements

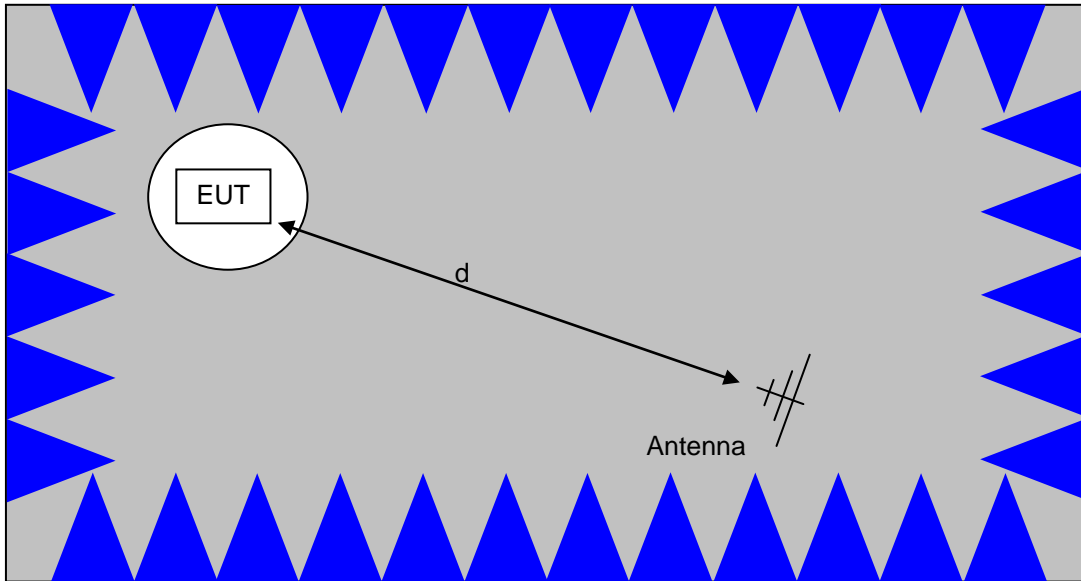

The anechoic materials on the walls and ceiling ensure compliance with the normalized site attenuation requirements of CISPR 16 / CISPR 22 / ANSI C63.4 for an alternate test site at the measurement distances used.

Floor-standing equipment is placed on the floor with insulating supports between the unit and the ground plane.

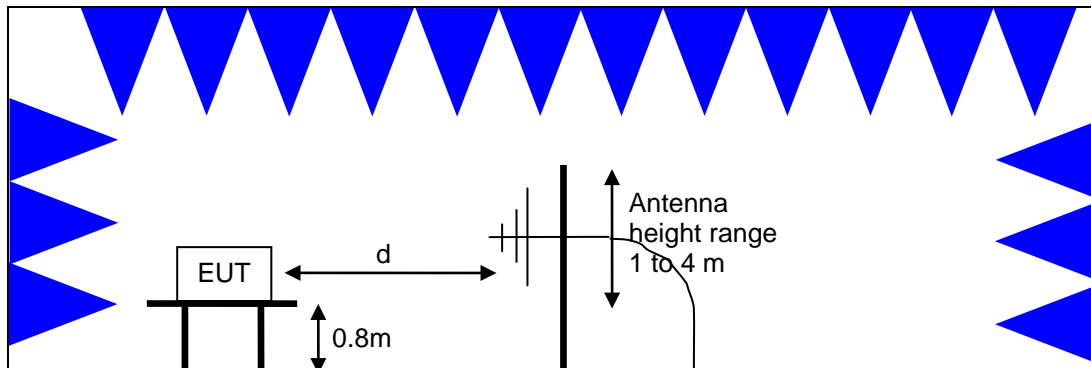

Test Configuration for Radiated Field Strength Measurements
Semi-Anechoic Chamber, Plan and Side Views

CONDUCTED EMISSIONS FROM ANTENNA PORT

Direct measurements of power, bandwidth and power spectral density are performed, where possible, with the antenna port of the EUT connected to either the power meter or spectrum analyzer via a suitable attenuator and/or filter. These are used to ensure that the front end of the measurement instrument is not overloaded by the fundamental transmission.

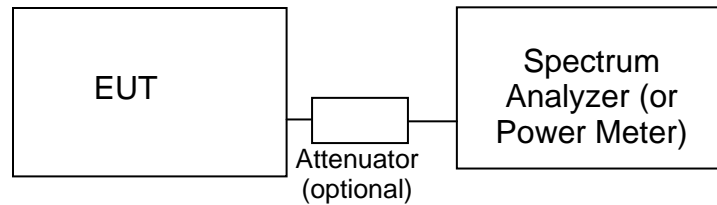

Test Configuration for Antenna Port Measurements

Measurement bandwidths (video and resolution) are set in accordance with the relevant standards and NTS Silicon Valley's test procedures for the type of radio being tested. When power measurements are made using a resolution bandwidth less than the signal bandwidth the power is calculated by summing the power across the signal bandwidth using either the analyzer channel power function or by capturing the trace data and calculating the power using software. In both cases the summed power is corrected to account for the equivalent noise bandwidth (ENBW) of the resolution bandwidth used.

If power averaging is used (typically for certain digital modulation techniques), the EUT is configured to transmit continuously. Power averaging is performed using either the built-in function of the analyzer or, if the analyzer does not feature power averaging, using external software. In both cases the average power is calculated over a number of sweeps (typically 100). When the EUT cannot be configured to continuously transmit then either the analyzer is configured to perform a gated sweep to ensure that the power is averaged over periods that the device is transmitting or power averaging is disabled and a max-hold feature is used.

If a power meter is used to make output power measurements the sensor head type (peak or average) is stated in the test data table.

BANDWIDTH MEASUREMENTS

The 6dB, 20dB, 26dB and/or 99% signal bandwidth are measured using the bandwidths recommended by ANSI C63.10 and RSS GEN.

SPECIFICATION LIMITS AND SAMPLE CALCULATIONS

The limits for conducted emissions are given in units of microvolts, and the limits for radiated emissions are given in units of microvolts per meter at a specified test distance. Data is measured in the logarithmic form of decibels relative to one microvolt, or dB microvolts (dBuV). For radiated emissions, the measured data is converted to the field strength at the antenna in dB microvolts per meter (dBuV/m). The results are then converted to the linear forms of uV and uV/m for comparison to published specifications.

For reference, converting the specification limits from linear to decibel form is accomplished by taking the base ten logarithm, then multiplying by 20. These limits in both linear and logarithmic form are as follows:

CONDUCTED EMISSIONS SPECIFICATION LIMITS: FCC 15.207; FCC 15.107(a), RSS GEN

The table below shows the limits for the emissions on the AC power line from an intentional radiator and a receiver.

Frequency (MHz)	Average Limit (dBuV)	Quasi Peak Limit (dBuV)
0.150 to 0.500	Linear decrease on logarithmic frequency axis between 56.0 and 46.0	Linear decrease on logarithmic frequency axis between 66.0 and 56.0
0.500 to 5.000	46.0	56.0
5.000 to 30.000	50.0	60.0

GENERAL TRANSMITTER RADIATED EMISSIONS SPECIFICATION LIMITS

The table below shows the limits for the spurious emissions from transmitters that fall in restricted bands¹ (with the exception of transmitters operating under FCC Part 15 Subpart D and RSS 210 Annex 9), the limits for all emissions from a low power device operating under the general rules of RSS 310 (tables 3 and 4), RSS 210 (table 2) and FCC Part 15 Subpart C section 15.209.

Frequency Range (MHz)	Limit (uV/m)	Limit (dBuV/m @ 3m)
0.009-0.490	2400/F _{KHz} @ 300m	67.6-20*log ₁₀ (F _{KHz}) @ 300m
0.490-1.705	24000/F _{KHz} @ 30m	87.6-20*log ₁₀ (F _{KHz}) @ 30m
1.705 to 30	30 @ 30m	29.5 @ 30m
30 to 88	100 @ 3m	40 @ 3m
88 to 216	150 @ 3m	43.5 @ 3m
216 to 960	200 @ 3m	46.0 @ 3m
Above 960	500 @ 3m	54.0 @ 3m

RECEIVER RADIATED SPURIOUS EMISSIONS SPECIFICATION LIMITS

The table below shows the limits for the spurious emissions from receivers as detailed in FCC Part 15.109, RSS 210 Table 2, RSS GEN Table 1 and RSS 310 Table 3. Note that receivers operating outside of the frequency range 30 MHz – 960 MHz are exempt from the requirements of 15.109.

Frequency Range (MHz)	Limit (uV/m @ 3m)	Limit (dBuV/m @ 3m)
30 to 88	100	40
88 to 216	150	43.5
216 to 960	200	46.0
Above 960	500	54.0

FCC 15.407 (a) OUTPUT POWER LIMITS

The table below shows the limits for output power and output power density. Where the signal bandwidth is less than 20 MHz the maximum output power is reduced to the power spectral density limit plus 10 times the log of the bandwidth (in MHz).

Operating Frequency (MHz)	Output Power	Power Spectral Density
5150 – 5250	50mW (17 dBm)	4 dBm/MHz
5250 – 5350	250 mW (24 dBm)	11 dBm/MHz
5725 – 5825	1 Watts (30 dBm)	17 dBm/MHz

¹ The restricted bands are detailed in FCC 15.203, RSS 210 Table 1 and RSS 310 Table 2

For system using antennas with gains exceeding 6dBi, the output power and power spectral density limits are reduced by 1dB for every dB the antenna gain exceeds 6dBi. Fixed point-to-point applications using the 5725 – 5825 MHz band may use antennas with gains of up to 23dBi without this limitation. If the gain exceeds 23dBi then the output power limit of 1 Watt is reduced by 1dB for every dB the gain exceeds 23dBi.

The peak excursion envelope is limited to 13dB.

OUTPUT POWER LIMITS –LELAN DEVICES

The table below shows the limits for output power and output power density defined by RSS 210. Where the signal bandwidth is less than 20 MHz the maximum output power is reduced to the power spectral density limit plus 10 times the log of the bandwidth (in MHz).

Operating Frequency (MHz)	Output Power	Power Spectral Density
5150 – 5250	200mW (23 dBm) eirp	10 dBm/MHz eirp
5250 – 5350	250 mW (24 dBm) ² 1W (30dBm) eirp	11 dBm/MHz
5470 – 5725	250 mW (24 dBm) ³ 1W (30dBm) eirp	11 dBm/MHz
5725 – 5825	1 Watts (30 dBm) 4W eirp	17 dBm/MHz

In addition, the power spectral density limit shall be reduced by 1dB for every dB the highest power spectral density exceeds the “average” power spectral density) by more than 3dB. The “average” power spectral density is determined by dividing the output power by $10\log(\text{EBW})$ where EBW is the 99% power bandwidth.

Fixed point-to-point applications using the 5725 – 5825 MHz band may use antennas with gains of up to 23dBi without this limitation. If the gain exceeds 23dBi then the output power limit of 1 Watt is reduced by 1dB for every dB the gain exceeds 23dBi.

SPURIOUS EMISSIONS LIMITS –UNII and LELAN DEVICES

The spurious emissions limits for signals below 1GHz are the FCC/RSS-GEN general limits. For emissions above 1GHz, signals in restricted bands are subject to the FCC/RSS GEN general limits. All other signals have a limit of –27dBm/MHz, which is a field strength of 68.3dBuV/m/MHz at a distance of 3m. For devices operating in the 5725-5850Mhz bands under the LELAN/UNII rules, the limit within 10MHz of the allocated band is increased to –17dBm/MHz.

SAMPLE CALCULATIONS - CONDUCTED EMISSIONS

Receiver readings are compared directly to the conducted emissions specification limit (decibel form) as follows:

$$R_r - S = M$$

² If EIRP exceeds 500mW the device must employ TPC

³ If EIRP exceeds 500mW the device must employ TPC

where:

R_r = Receiver Reading in dBuV

S = Specification Limit in dBuV

M = Margin to Specification in +/- dB

SAMPLE CALCULATIONS - RADIATED EMISSIONS

Receiver readings are compared directly to the specification limit (decibel form). The receiver internally corrects for cable loss, preamplifier gain, and antenna factor. The calculations are in the reverse direction of the actual signal flow, thus cable loss is added and the amplifier gain is subtracted. The Antenna Factor converts the voltage at the antenna coaxial connector to the field strength at the antenna elements.

A distance factor, when used for electric field measurements above 30MHz, is calculated by using the following formula:

$$F_d = 20 * \text{LOG}_{10} (D_m/D_s)$$

where:

F_d = Distance Factor in dB

D_m = Measurement Distance in meters

D_s = Specification Distance in meters

For electric field measurements below 30MHz the extrapolation factor is either determined by making measurements at multiple distances or a theoretical value is calculated using the formula:

$$F_d = 40 * \text{LOG}_{10} (D_m/D_s)$$

Measurement Distance is the distance at which the measurements were taken and Specification Distance is the distance at which the specification limits are based. The antenna factor converts the voltage at the antenna coaxial connector to the field strength at the antenna elements.

The margin of a given emission peak relative to the limit is calculated as follows:

$$R_c = R_r + F_d$$

and

$$M = R_c - L_s$$

where:

R_r = Receiver Reading in dBuV/m

F_d = Distance Factor in dB

R_c = Corrected Reading in dBuV/m

L_s = Specification Limit in dBuV/m

M = Margin in dB Relative to Spec

SAMPLE CALCULATIONS - FIELD STRENGTH TO EIRP CONVERSION

Where the radiated electric field strength is expressed in terms of the equivalent isotropic radiated power (eirp), or where a field strength measurement of output power is made in lieu of a direct measurement, the following formula is used to convert between eirp and field strength at a distance of d (meters) from the equipment under test:

$$E = \frac{1000000 \sqrt{30 P}}{d} \text{ microvolts per meter}$$

where P is the eirp (Watts)

For a measurement at 3m the conversion from a logarithmic value for field strength (dBuV/m) to an eirp power (dBm) is -95.3dB.

Appendix A Test Equipment Calibration Data

<u>Manufacturer</u>	<u>Description</u>	<u>Model</u>	<u>Asset #</u>	<u>Cal Due</u>
Radio Antenna Port (Duty Cycle), 29-Sep-14				
Agilent Technologies	PSA, Spectrum Analyzer, (installed options, 111, 115, 123, 1DS, B7J, HYX,	E4446A	2139	4/8/2015
Radiated Power, 05-Aug-14				
Rohde & Schwarz	EMI Test Receiver, 20 Hz-7 GHz	ESIB7	1630	6/21/2015
EMCO	Antenna, Horn, 1-18 GHz	3115	1561	6/27/2016
Radiated Emissions, 1,000 - 6,500 MHz, 09-Oct-14				
EMCO	Antenna, Horn, 1-18 GHz	3115	1561	6/27/2016
Rohde & Schwarz	EMI Test Receiver, 20 Hz-7 GHz	ESIB7	1630	6/21/2015
Radiated Emissions, 1,000 - 18,000 MHz, 10-Oct-14				
Hewlett Packard	Microwave Preamplifier, 1- 26.5GHz	8449B	263	3/25/2015
Hewlett Packard	SpecAn 30 Hz -40 GHz, SV (SA40) Red	8564E (84125C)	1148	9/20/2015
EMCO	Antenna, Horn, 1-18 GHz	3115	1561	6/27/2016
Rohde & Schwarz	EMI Test Receiver, 20 Hz-7 GHz	ESIB7	1630	6/21/2015
Micro-Tronics	Band Reject Filter, 5150-5350 MHz	BRC50703-02	2239	9/16/2015
Radiated Emissions, 1000 - 40,000 MHz, 13-Oct-14				
Hewlett Packard	Microwave Preamplifier, 1- 26.5GHz	8449B	263	3/25/2015
Hewlett Packard	Head (Inc flex cable, 1143, 2198) Red	84125C	1145	6/17/2015
Hewlett Packard	SpecAn 30 Hz -40 GHz, SV (SA40) Red	8564E (84125C)	1148	9/20/2015
EMCO	Antenna, Horn, 1-18 GHz	3115	1561	6/27/2016
Rohde & Schwarz	EMI Test Receiver, 20 Hz-7 GHz	ESIB7	1630	6/21/2015
Hewlett Packard	High Pass filter, 8.2 GHz (Purple System)	P/N 84300-80039	1767	11/26/2014
A. H. Systems	Red System Horn, 18-40GHz	SAS-574, p/n: 2581	2161	7/9/2015
Micro-Tronics	Band Reject Filter, 5150-5350 MHz	BRC50703-02	2239	9/16/2015
Micro-Tronics	Band Reject Filter, 5470-5725 MHz	BRC50704-02	2240	9/16/2015
Micro-Tronics	Band Reject Filter, 5725-5875 MHz	BRC50705-02	2241	9/16/2015
Radio Antenna Port (Power and Spurious Emissions), 14-Oct-14				
Agilent Technologies	3Hz -44GHz PSA Spectrum Analyzer	E4446A	2796	2/6/2015
Radio Antenna Port (Power and Spurious Emissions), 15-Oct-14				
Agilent Technologies	3Hz -44GHz PSA Spectrum Analyzer	E4446A	2796	2/6/2015
Radiated Emissions, Power EIRP, 17-Oct-14				
Rohde & Schwarz	EMI Test Receiver, 20 Hz-7 GHz	ESIB7	1630	6/21/2015
EMCO	Antenna, Horn, 1-18 GHz	3115	2870	8/20/2015



Appendix B Test Data

T96435 Pages 27 - 69



EMC Test Data

Client:	Vivint Wireless	Job Number:	J96375
Product	SR1430 (4x4 5GHz 802.11 master)	T-Log Number:	T96435
		Project Manager:	Christine Krebill
Contact:	Venkat Kalkunte	Project Coordinator:	-
Emissions Standard(s):	FCC 15.B / 15.407 / 15.247 (Old Rules)	Class:	A
Immunity Standard(s):	-	Environment:	-

EMC Test Data

For The

Vivint Wireless

Product

SR1430 (4x4 5GHz 802.11 master)

Date of Last Test: 11/12/2014



EMC Test Data

Client: Vivint Wireless	Job Number: J96375
Model: SR1430 (4x4 5GHz 802.11 master)	T-Log Number: T96435
	Project Manager: Christine Krebill
Contact: Venkat Kalkunte	Project Coordinator: -
Standard: FCC 15.B / 15.407 / 15.247 (Old Rules)	Class: N/A

Power vs. Data Rate

In normal operating modes the card uses power settings stored on EEPROM to set the output power. For a given nominal output power the actual transmit power normally is reduced as the data rate increases, therefore testing was performed at the data rate in the mode with highest power to determine compliance with the requirements.

The following power measurements were made using a GATED average power meter and with the device configured in a continuous transmit mode on Chain 1 at the various data rates in each mode to verify the highest power mode:

Sample Notes

Sample S/N: NTS 2014-3285

Driver: -

Date of Test: 8/5/2014

Test Engineer: Jack Liu

Test Location: FT Chamber# 4

Mode	Data Rate	Power (dBm)	Power setting
802.11n/ac 40MHz	27	37.0	13.0
	54	36.6	
	81	36.4	
	108	36.0	
	162	35.9	
	216	35.7	
	243	35.6	
	270	35.5	

Note : Power setting - the software power setting used during testing, included for reference only.

Note 1 : Performed by radiated method. Fixed position at Vertical. The power reading is EIRP.

Client: Vivint Wireless	Job Number: J96375
Model: SR1430 (4x4 5GHz 802.11 master)	T-Log Number: T96435
	Project Manager: Christine Krebill
Contact: Venkat Kalkunte	Project Coordinator: -
Standard: FCC 15.B / 15.407 / 15.247 (Old Rules)	Class: N/A

Duty Cycle

Date of Test: 9/29/2014
 Test Engineer: Jack Liu
 Test Location: FT Chamber #4

Duty cycle measurements performed on the worse case data rate for power.
 Notes: Measurements taken with maximum RBW/VBW settings allowed.

Mode	Data Rate	Duty Cycle (x)	Constant DC?	T (ms)	Pwr Cor Factor*	Lin Volt Cor Factor**	Min VBW for FS (Hz)
n40	MCS8	93.0%	Yes	1.29	0.31	0.63	775

* Correction factor when using RMS/Power averaging - $10 \cdot \log(1/x)$
 ** Correction factor when using linear voltage average - $20 \cdot \log(1/x)$
 T = Minimum transmission duration

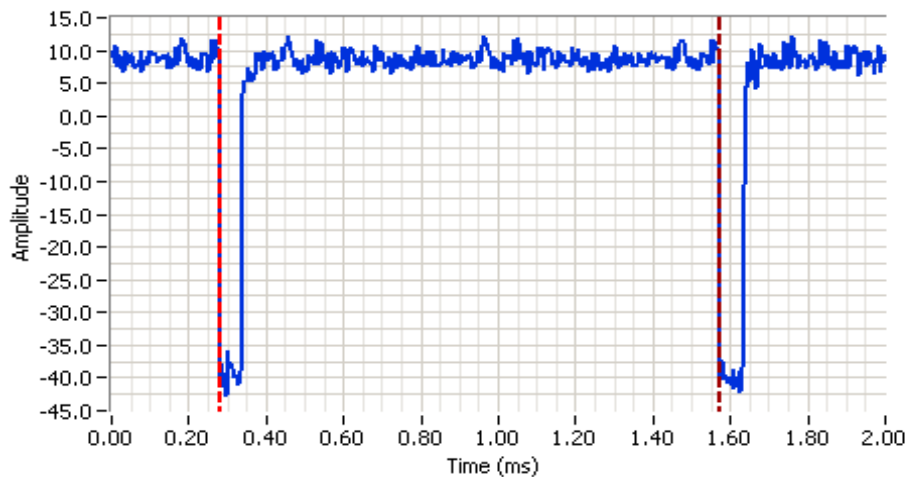

Analyzer Settings

Rohde&Schwarz,ESI
 CF: 5200.000 MHz
 SPAN: 0.000 MHz
 RB: 3.000 MHz
 VB: 3.000 MHz
 Detector: POS
 Attn: 30 DB
 RL Offset: 11.0 DB
 Sweep Time: 2.0ms
 Ref Lvl: 16.0 DBM

Comments

802.11n 40MHz MCS 8
 On time: 1.20ms
 Cycle time: 1.29ms
 Duty cycle: 93.0%

Cursor 1	0.2812	20.00		Delta Time (ms)	1.29
Cursor 2	1.5729	20.00		Delta Amplitude	0.00



EMC Test Data

Client:	Vivint Wireless	Job Number:	J96375
Model:	SR1430 (4x4 5GHz 802.11 master)	T-Log Number:	T96435
		Project Manager:	Christine Krebill
Contact:	Venkat Kalkunte	Project Coordinator:	-
Standard:	FCC 15.B / 15.407 / 15.247 (Old Rules)	Class:	N/A

RSS 210 and FCC 15.407 (UNII) Radiated Spurious Emissions

Test Specific Details

Objective: The objective of this test session is to perform final qualification testing of the EUT with respect to the specification listed above.

General Test Configuration

The EUT and all local support equipment were located on the turntable for radiated spurious emissions testing.
For radiated emissions testing the measurement antenna was located 3 meters from the EUT, unless otherwise noted.

Ambient Conditions:

Temperature:	24 °C
Rel. Humidity:	38 %

Modifications Made During Testing

No modifications were made to the EUT during testing

Deviations From The Standard

No deviations were made from the requirements of the standard.



EMC Test Data

Client: Vivint Wireless	Job Number: J96375
Model: SR1430 (4x4 5GHz 802.11 master)	T-Log Number: T96435
	Project Manager: Christine Krebill
Contact: Venkat Kalkunte	Project Coordinator: -
Standard: FCC 15.B / 15.407 / 15.247 (Old Rules)	Class: N/A

Summary of Results

Run #	Mode	Channel	Target Power Setting	Passing Power Setting	Test Performed	Limit	Result / Margin
1	n40	62 - 5310MHz	15	13	Restricted Band Edge at 5250 MHz	15.209	43.4 dBµV/m @ 5249.7 MHz (-10.6 dB)
	n40		15	13	Restricted Band Edge at 5350 MHz	15.209	53.5 dBµV/m @ 5350.0 MHz (-0.5 dB)
2	n40	102 - 5510MHz	14	12	Restricted Band Edge at 5460 MHz	15.209	46.9 dBµV/m @ 5460.0 MHz (-7.1 dB)
	n40				Band Edge 5460 - 5470 MHz	15E	66.8 dBµV/m @ 5469.9 MHz (-1.5 dB)
	n40	110 - 5550MHz	21	20	Restricted Band Edge at 5460 MHz	15.209	51.6 dBµV/m @ 5459.9 MHz (-2.4 dB)
	n40				Band Edge 5460 - 5470 MHz	15E	66.3 dBµV/m @ 5470.0 MHz (-2.0 dB)
	n40				20dBc Bandedge at 5600MHz	15E	20dBc @ 5581.46 MHz
	n40	134 - 5670MHz	19	16	20dBc Bandedge at 5650MHz	15E	20dBc @ 5650.27 MHz
n40	Band Edge 5725MHz				15E	52.7 dBµV/m @ 5727.7 MHz (-1.3 dB)	



EMC Test Data

Client: Vivint Wireless	Job Number: J96375
Model: SR1430 (4x4 5GHz 802.11 master)	T-Log Number: T96435
	Project Manager: Christine Krebill
Contact: Venkat Kalkunte	Project Coordinator: -
Standard: FCC 15.B / 15.407 / 15.247 (Old Rules)	Class: N/A

Mode	Data Rate	Duty Cycle (x)	Constant DC?	T (ms)	Pwr Cor Factor*	Lin Volt Cor Factor**	Min VBW for FS (Hz)
n40	MCS8	93.0%	Yes	1.29	0.31	0.63	775

Sample Notes

Sample S/N: C7105S11304001R With 2dB+3dB Pad on each antenna port

Driver: -

Antenna: ~10dBi

Procedure Comments:

Measurements performed in accordance with FCC KDB 789033

Peak measurements performed with: RBW=1MHz, VBW=3MHz, peak detector, max hold, auto sweep time

Unless otherwise stated/noted, emission has duty cycle $\geq 98\%$ and was measured using RBW=1MHz, VBW=10Hz, peak detector, linear average mode, auto sweep time, max hold.

Measurement Specific Notes:

Note 1a:	For emissions outside of the restricted bands the limit is -27dBm/MHz eirp (68.3dBuV/m). The measurement method required is a peak measurement (RB=1MHz, VB \geq 3MHz, peak detector). Per KDB 789033 2) c) (i), compliance can be demonstrated by meeting the average and peak limits of 15.209, as an alternative.
Note 1b:	For emissions outside of the restricted bands the limit is -27dBm/MHz eirp (68.3dBuV/m) (or -17dBm/MHz eirp (78.3dBuV/m)). The measurement method required is a peak measurement (RB=1MHz, VB \geq 3MHz, peak detector). Per KDB 789033 D02 G) 2) (c), compliance can be demonstrated by meeting the average and peak limits of 15.209, as an alternative.
Note 2:	Emission has duty cycle $\geq 98\%$, average measurement performed: RBW=1MHz, VBW=3MHz, RMS, Power averaging, auto sweep, trace average 100 traces
Note 3:	Emission has duty cycle $< 98\%$, but constant, average measurement performed: RBW=1MHz, VBW=10Hz, peak detector, linear averaging, auto sweep, trace average 100 * 1/DC traces, measurement corrected by Linear Voltage correction factor
Note 4:	Emission has duty cycle $< 98\%$ and is NOT constant, average measurement performed: RBW=1MHz, VBW $> 1/T$, peak detector, linear average mode, sweep time auto, max hold. Max hold for 50*(1/DC) traces
Note 5:	Emission has duty cycle $< 98\%$, but constant, average measurement performed: RBW=1MHz, VBW=3MHz, RMS, Power averaging, auto sweep, trace average 100 * 1/DC traces, measurement corrected by Pwr correction factor
Note 6:	Plots of the average and peak bandedge do not account for any duty cycle correction. Refer to the tabluar results for final measurements.



EMC Test Data

Client: Vivint Wireless	Job Number: J96375
Model: SR1430 (4x4 5GHz 802.11 master)	T-Log Number: T96435
	Project Manager: Christine Krebill
Contact: Venkat Kalkunte	Project Coordinator: -
Standard: FCC 15.B / 15.407 / 15.247 (Old Rules)	Class: N/A

Run #1: Radiated Bandedge Measurements, 5150-5250MHz

Date of Test: 10/17/14
 Test Engineer: Rafael Varelas

Test Location: FT Chamber #4
 EUT Voltage: PoE

Channel: 62 - 5310MHz Mode: n40 Power Setting: 13
 Tx Chain: 4Tx Data Rate: MCS 8

5250 MHz Band Edge Signal Radiated Field Strength

Frequency	Level	Pol	FCC 15.209		Detector	Azimuth	Height	Comments
MHz	dB μ V/m	v/h	Limit	Margin	Pk/QP/Avg	degrees	meters	
5249.740	43.4	V	54.0	-10.6	AVG	360	1.8	POS; RB 1 MHz; VB: 10 Hz
5244.690	54.6	V	74.0	-19.4	PK	360	1.8	POS; RB 1 MHz; VB: 3 MHz
5249.980	43.3	H	54.0	-10.7	AVG	360	1.9	POS; RB 1 MHz; VB: 10 Hz
5249.760	54.2	H	74.0	-19.8	PK	360	1.9	POS; RB 1 MHz; VB: 3 MHz

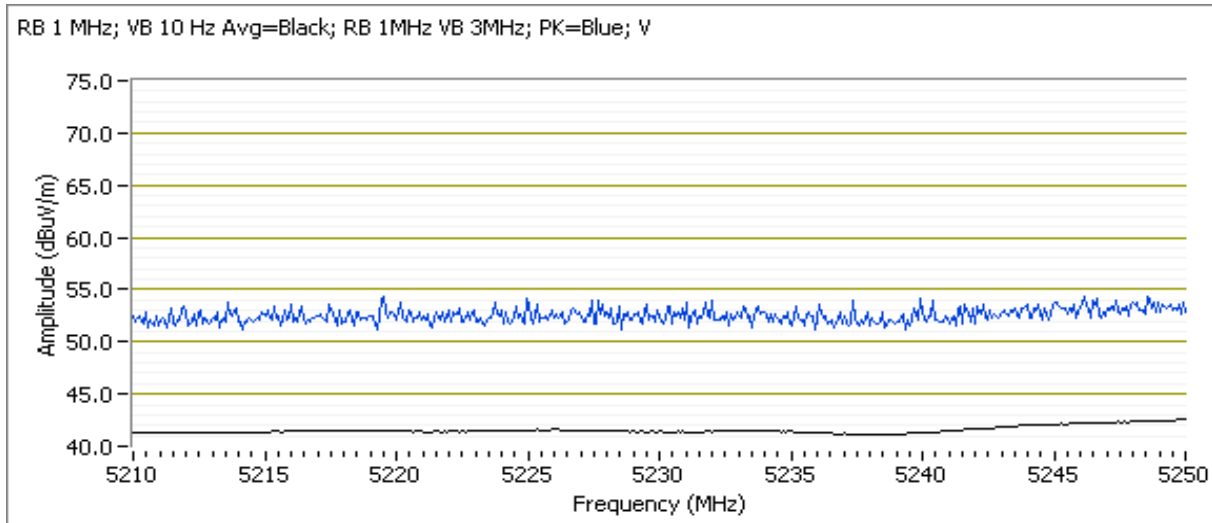



EMC Test Data

Client: Vivint Wireless	Job Number: J96375
Model: SR1430 (4x4 5GHz 802.11 master)	T-Log Number: T96435
	Project Manager: Christine Krebill
Contact: Venkat Kalkunte	Project Coordinator: -
Standard: FCC 15.B / 15.407 / 15.247 (Old Rules)	Class: N/A

Date of Test: 10/09/14
 Test Engineer: Mehran Birgani

Test Location: FT Chamber#4
 EUT Voltage: PoE

Channel: 62 - 5310MHz Mode: n40 Power Setting: 13
 Tx Chain: 4Tx Data Rate: MCS 8

5350 MHz Band Edge Signal Radiated Field Strength

Frequency	Level	Pol	FCC 15.209		Detector	Azimuth	Height	Comments
MHz	dB μ V/m	v/h	Limit	Margin	Pk/QP/Avg	degrees	meters	
5350.000	53.5	V	54.0	-0.5	AVG	91	2.0	POS; RB 1 MHz; VB: 10 Hz
5350.720	52.7	H	54.0	-1.3	AVG	90	1.7	POS; RB 1 MHz; VB: 10 Hz
5352.080	66.6	V	74.0	-7.4	PK	91	2.0	POS; RB 1 MHz; VB: 3 MHz
5350.880	65.7	H	74.0	-8.3	PK	90	1.7	POS; RB 1 MHz; VB: 3 MHz

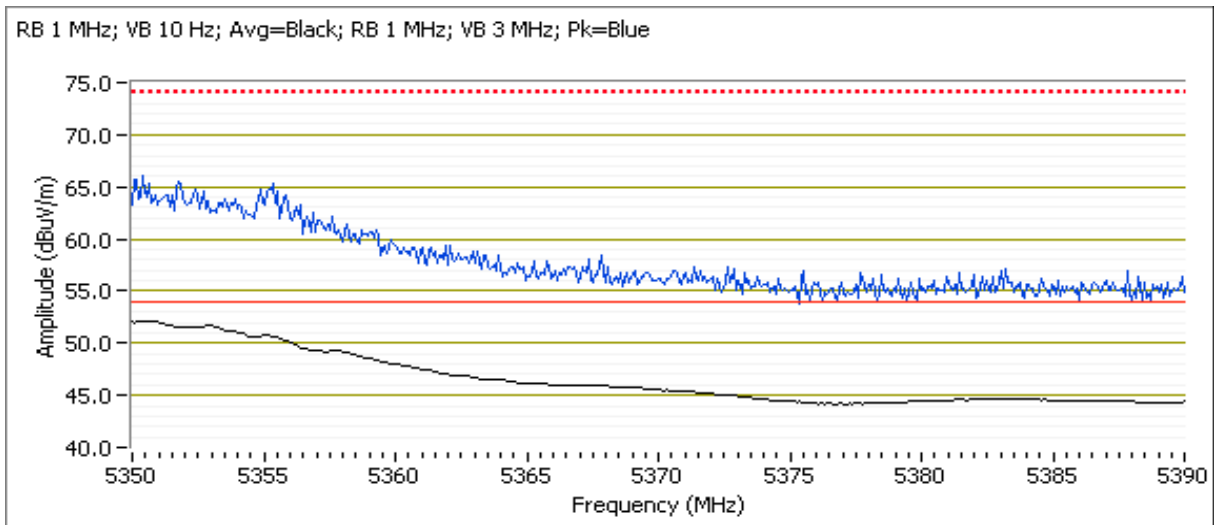



EMC Test Data

Client: Vivint Wireless	Job Number: J96375
Model: SR1430 (4x4 5GHz 802.11 master)	T-Log Number: T96435
	Project Manager: Christine Krebill
Contact: Venkat Kalkunte	Project Coordinator: -
Standard: FCC 15.B / 15.407 / 15.247 (Old Rules)	Class: N/A

Run #2: Radiated Bandedge Measurements, 5470-5725MHz

Date of Test: 10/09/14

Test Location: FT Chamber#4

Test Engineer: Mehran Birgani

EUT Voltage: PoE

Channel: 102 - 5510MHz

Mode: n40

Power Setting: 12

Tx Chain: 4Tx

Data Rate: MCS8

5460 MHz Band Edge Signal Radiated Field Strength

Frequency MHz	Level dB μ V/m	Pol v/h	FCC 15.209		Detector PK/QP/Avg	Azimuth degrees	Height meters	Comments
			Limit	Margin				
5460.000	46.9	H	54.0	-7.1	AVG	92	1.8	Note 3; POS; RB 1MHz; VB: 10Hz
5460.000	46.5	V	54.0	-7.5	AVG	90	2.1	Note 3; POS; RB 1MHz; VB: 10Hz
5459.920	59.2	V	74.0	-14.8	PK	90	2.1	POS; RB 1 MHz; VB: 3 MHz
5459.280	58.9	H	74.0	-15.1	PK	92	1.8	POS; RB 1 MHz; VB: 3 MHz

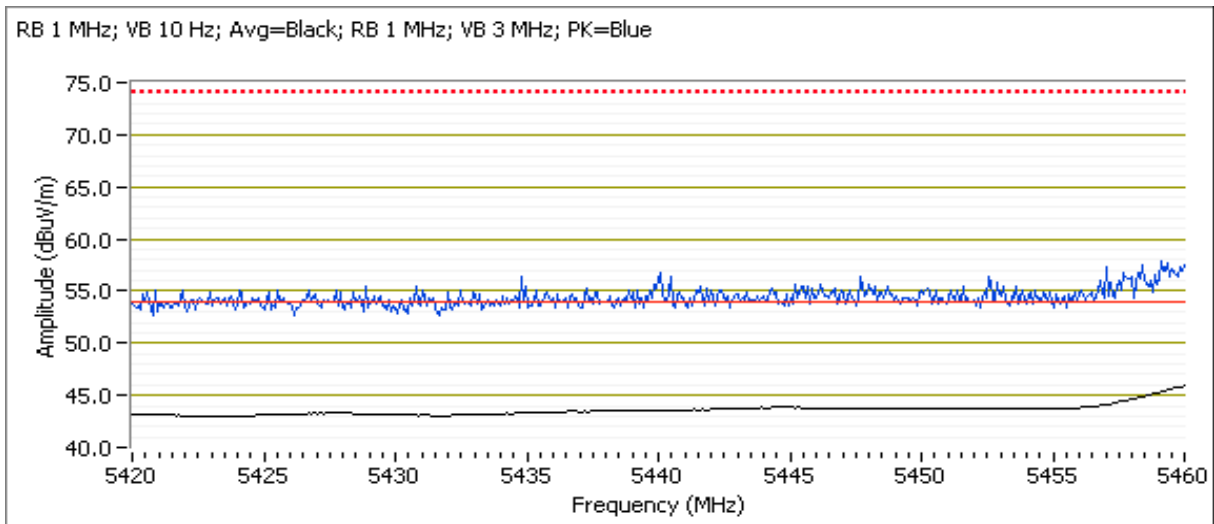



EMC Test Data

Client: Vivint Wireless	Job Number: J96375
Model: SR1430 (4x4 5GHz 802.11 master)	T-Log Number: T96435
	Project Manager: Christine Krebill
Contact: Venkat Kalkunte	Project Coordinator: -
Standard: FCC 15.B / 15.407 / 15.247 (Old Rules)	Class: N/A

Channel: 102 - 5510MHz Mode: n40 Power Setting: 12
 Tx Chain: 4Tx Data Rate: MCS8

5470 MHz Band Edge Signal Radiated Field Strength

Frequency MHz	Level dB μ V/m	Pol v/h	15.E		Detector Pk/QP/Avg	Azimuth degrees	Height meters	Comments
			Limit	Margin				
5469.900	66.8	V	68.3	-1.5	PK	90	2.1	POS; RB 1 MHz; VB: 3 MHz
5466.890	66.0	H	68.3	-2.3	PK	92	1.8	POS; RB 1 MHz; VB: 3 MHz

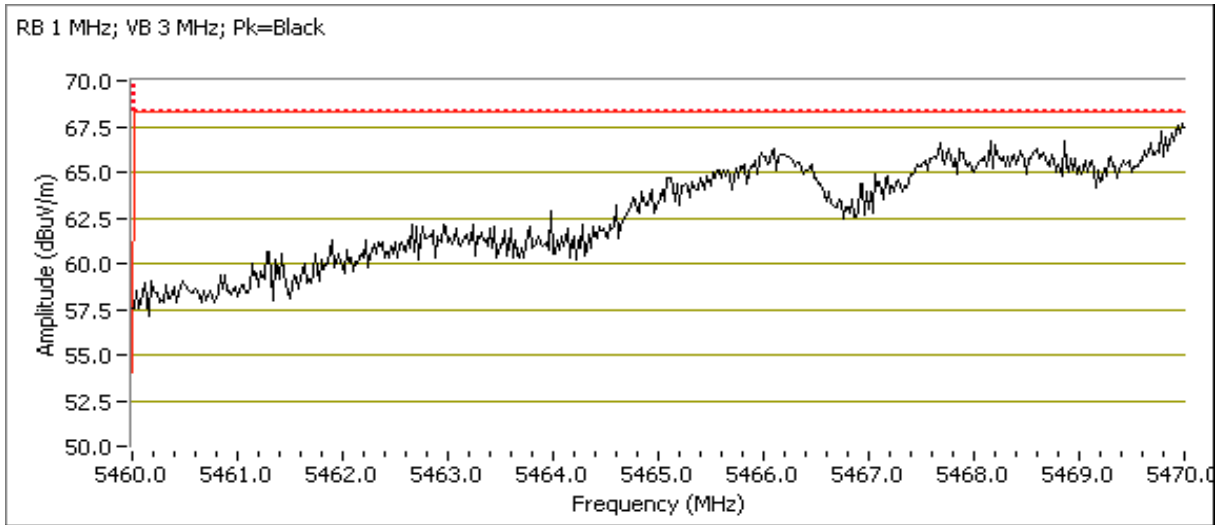



EMC Test Data

Client: Vivint Wireless	Job Number: J96375
Model: SR1430 (4x4 5GHz 802.11 master)	T-Log Number: T96435
	Project Manager: Christine Krebill
Contact: Venkat Kalkunte	Project Coordinator: -
Standard: FCC 15.B / 15.407 / 15.247 (Old Rules)	Class: N/A

Date of Test: 10/9/14, 10/13/14
 Test Engineer: Mehran Birgani / Rafael Varelas

Test Location: FT Chamber#4
 EUT Voltage: PoE

Channel: 110 - 5550MHz Mode: n40 Power Setting: 20
 Tx Chain: 4Tx Data Rate: MCS8

5460 MHz Band Edge Signal Radiated Field Strength

Frequency MHz	Level dB μ V/m	Pol v/h	FCC 15.209		Detector Pk/QP/Avg	Azimuth degrees	Height meters	Comments
			Limit	Margin				
5459.920	51.6	H	54.0	-2.4	AVG	93	1.8	Note 3; POS; RB 1MHz; VB: 10Hz
5460.000	51.0	V	54.0	-3.0	AVG	92	2.0	Note 3; POS; RB 1MHz; VB: 10Hz
5459.360	65.8	H	74.0	-8.2	PK	93	1.8	POS; RB 1 MHz; VB: 3 MHz
5453.350	63.0	V	74.0	-11.0	PK	92	2.0	POS; RB 1 MHz; VB: 3 MHz

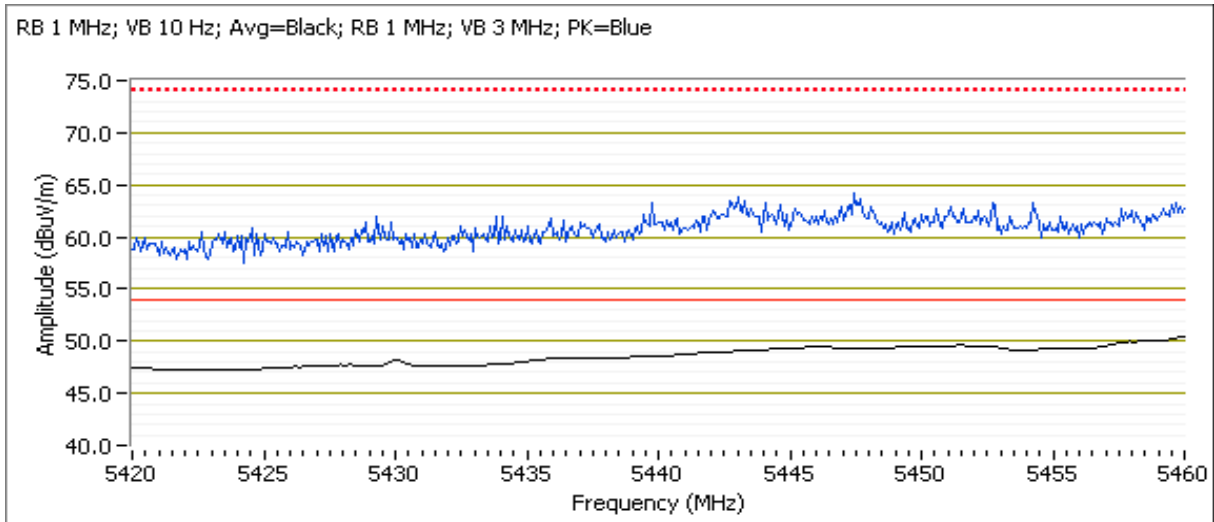



EMC Test Data

Client: Vivint Wireless	Job Number: J96375
Model: SR1430 (4x4 5GHz 802.11 master)	T-Log Number: T96435
	Project Manager: Christine Krebill
Contact: Venkat Kalkunte	Project Coordinator: -
Standard: FCC 15.B / 15.407 / 15.247 (Old Rules)	Class: N/A

Channel: 110 - 5550MHz Mode: n40 Power Setting: 20
 Tx Chain: 4Tx Data Rate: MCS8

5470 MHz Band Edge Signal Radiated Field Strength

Frequency MHz	Level dB μ V/m	Pol v/h	15.E		Detector Pk/QP/Avg	Azimuth degrees	Height meters	Comments
			Limit	Margin				
5469.980	66.3	V	68.3	-2.0	PK	92	2.0	POS; RB 1 MHz; VB: 3 MHz
5469.200	65.8	H	68.3	-2.5	PK	93	1.8	POS; RB 1 MHz; VB: 3 MHz

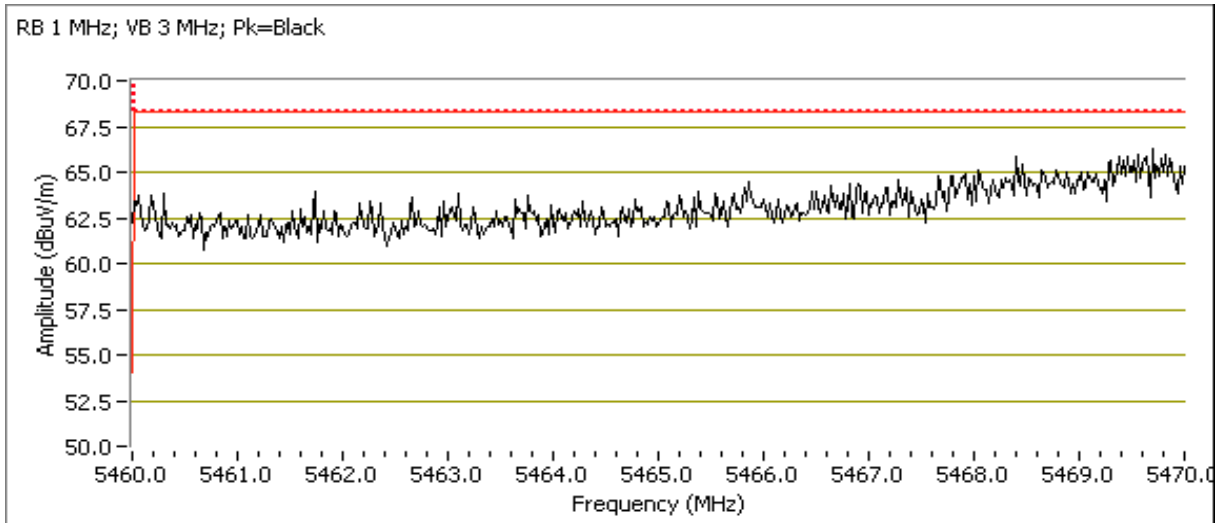



EMC Test Data

Client: Vivint Wireless	Job Number: J96375
Model: SR1430 (4x4 5GHz 802.11 master)	T-Log Number: T96435
	Project Manager: Christine Krebill
Contact: Venkat Kalkunte	Project Coordinator: -
Standard: FCC 15.B / 15.407 / 15.247 (Old Rules)	Class: N/A

20dBc plot at 5600MHz

Measurement performed RBW=1MHz, VBW=3MHz, Peak Detector, Max hold

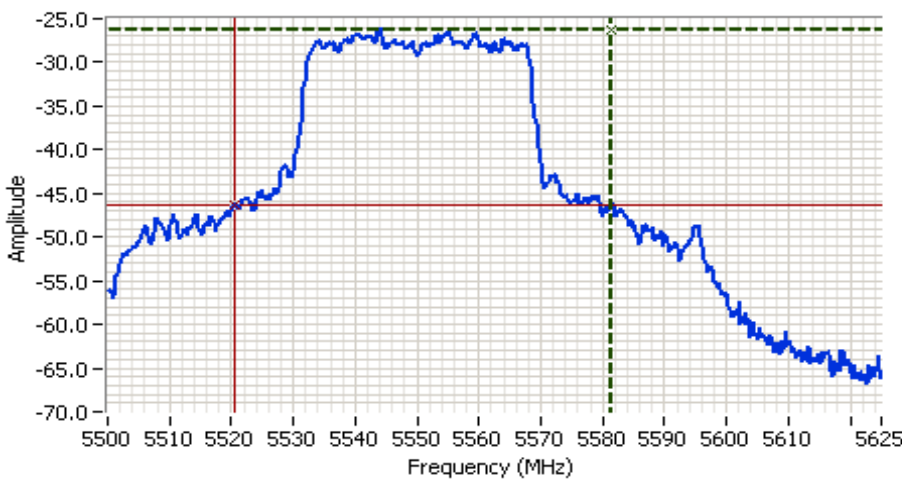

Analyzer Settings

HP8564E
 CF: 5562.500 MHz
 SPAN: 125.000 MHz
 RB: 1.000 MHz
 VB: 3.000 MHz
 Detector: POS
 Attn: 10 DB
 RL Offset: 0.0 DB
 Sweep Time: 50.0ms
 Ref Lvl: -24.8 DBM

Comments

20dB BW: 60.833 MHz

Cursor 1	5581.4583	-26.25		Delta Freq.	60.833
Cursor 2	5520.6250	-46.25		Delta Amplitude	20.00





EMC Test Data

Client: Vivint Wireless	Job Number: J96375
Model: SR1430 (4x4 5GHz 802.11 master)	T-Log Number: T96435
	Project Manager: Christine Krebill
Contact: Venkat Kalkunte	Project Coordinator: -
Standard: FCC 15.B / 15.407 / 15.247 (Old Rules)	Class: N/A

Date of Test: 10/10/14, 10/13/14
 Test Engineer: Jack Liu / Rafael Varelas

EUT Voltage: POE
 Test Location: Chamber 4

Channel: 134 - 5670MHz
 Tx Chain: 4Tx

Mode: n40
 Data Rate: MCS8

Power Setting: 17

20dBc plot at 5650MHz

Measurement performed RBW=1MHz, VBW=3MHz, Peak Detector, Max hold

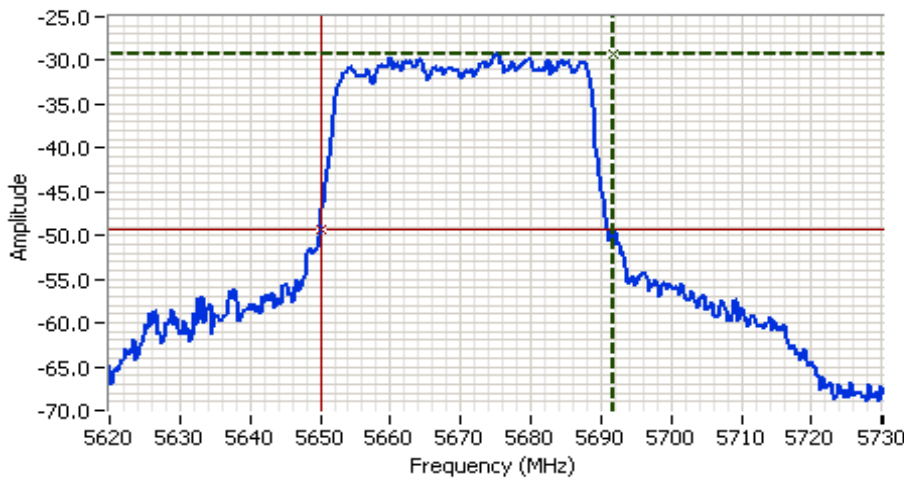

Analyzer Settings

HP8564E
 CF: 5650.000 MHz
 SPAN: 160.380 MHz
 RB: 1.000 MHz
 VB: 3.000 MHz
 Detector: POS
 Attn: 10 DB
 RL Offset: 0.0 DB
 Sweep Time: 50.0ms
 Ref Lvl: -24.8 DBM

Comments

20dB BW: 41.431 MHz

Cursor 1	5691.6988	-29.33	
Cursor 2	5650.2673	-49.33	

Delta Freq.	41.431
Delta Amplitude	20.00





EMC Test Data

Client: Vivint Wireless	Job Number: J96375
Model: SR1430 (4x4 5GHz 802.11 master)	T-Log Number: T96435
Contact: Venkat Kalkunte	Project Manager: Christine Krebill
Standard: FCC 15.B / 15.407 / 15.247 (Old Rules)	Project Coordinator: -
	Class: N/A

Channel: 134 - 5670MHz Mode: n40 Power Setting: 16
 Tx Chain: 4Tx Data Rate: MCS8

5725 MHz Band Edge Signal Radiated Field Strength

Frequency MHz	Level dB μ V/m	Pol v/h	15.E		Detector PK/QP/Avg	Azimuth degrees	Height meters	Comments
			Limit	Margin				
5727.730	52.7	H	54.0	-1.3	AVG	94	1.8	Note3; POS; RB 1 MHz; VB: 10 Hz
5726.520	65.5	H	74.0	-8.5	PK	94	1.8	POS; RB 1 MHz; VB: 3 MHz
5726.520	65.5	H	68.3	-2.8	PK	94	1.8	POS; RB 1 MHz; VB: 3 MHz
5725.080	51.8	V	54.0	-2.2	AVG	92	2.0	Note3; POS; RB 1 MHz; VB: 10 Hz
5727.320	65.4	V	74.0	-8.6	PK	92	2.0	POS; RB 1 MHz; VB: 3 MHz
5727.320	65.4	V	68.3	-2.9	PK	92	2.0	POS; RB 1 MHz; VB: 3 MHz

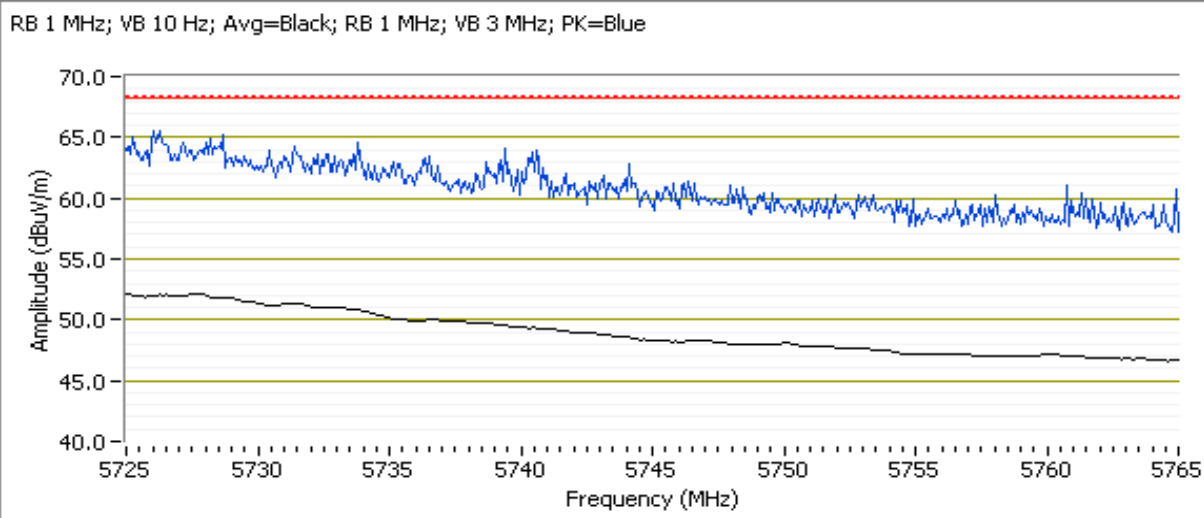



EMC Test Data

Client: Vivint Wireless	Job Number: J96375
Model: SR1430 (4x4 5GHz 802.11 master)	T-Log Number: T96435
	Project Manager: Christine Krebill
Contact: Venkat Kalkunte	Project Coordinator: -
Standard: FCC 15.B / 15.407 / 15.247 (Old Rules)	Class: N/A

RSS 210 and FCC 15.407 (UNII) Radiated Spurious Emissions

Test Specific Details

Objective: The objective of this test session is to perform final qualification testing of the EUT with respect to the specification listed above.

General Test Configuration

The EUT and all local support equipment were located on the turntable for radiated spurious emissions testing. For radiated emissions testing the measurement antenna was located 3 meters from the EUT, unless otherwise noted.

Ambient Conditions: Temperature: 23 °C
 Rel. Humidity: 40 %

Summary of Results

Run #	Mode	Channel	Target Power Setting	Passing Power Setting	Test Performed	Limit	Result / Margin
2	n40	54 - 5270MHz	21	21	Radiated Emissions, 1 - 40 GHz	FCC 15.209 / 15 E	52.5 dBµV/m @ 15798.4 MHz (-1.5 dB)
	n40	62 - 5310MHz	15	21	Radiated Emissions, 1 - 40 GHz	FCC 15.209 / 15 E	53.7 dBµV/m @ 15929.2 MHz (-0.3 dB)
3	n40	102 - 5510MHz	14	21	Radiated Emissions, 1 - 40 GHz	FCC 15.209 / 15 E	53.8 dBµV/m @ 11018.0 MHz (-0.2 dB)
	n40	110 - 5510MHz	21	21	Radiated Emissions, 1 - 40 GHz	FCC 15.209 / 15 E	53.2 dBµV/m @ 11098.7 MHz (-0.8 dB)
	n40	142- 5710MHz	21	21	Radiated Emissions, 1 - 40 GHz	FCC 15.209 / 15 E	50.4 dBµV/m @ 22840.7 MHz (-3.6 dB)

Client:	Vivint Wireless	Job Number:	J96375
Model:	SR1430 (4x4 5GHz 802.11 master)	T-Log Number:	T96435
		Project Manager:	Christine Krebill
Contact:	Venkat Kalkunte	Project Coordinator:	-
Standard:	FCC 15.B / 15.407 / 15.247 (Old Rules)	Class:	N/A

Modifications Made During Testing

No modifications were made to the EUT during testing

Deviations From The Standard

No deviations were made from the requirements of the standard.

Procedure Comments:

Measurements performed in accordance with FCC KDB 789033

Peak measurements performed with: RBW=1MHz, VBW=3MHz, peak detector, max hold, auto sweep time

Unless otherwise stated/noted, emission has duty cycle $\geq 98\%$ and was measured using RBW=1MHz, VBW=10Hz, peak detector, linear average mode, auto sweep time, max hold.

Preliminary testing showed no radio related emissions below 1GHz

Mode	Data Rate	Duty Cycle (x)	Constant DC?	T (ms)	Pwr Cor Factor*	Lin Volt Cor Factor**	Min VBW for FS (Hz)
n40	MCS8	93.0%	Yes	1.29	0.31	0.63	775

Sample Notes

Sample S/N: C7105S11304001R With 2dB+3dB Pad on each antenna port

Driver: -

Antenna: ~10dBi

Measurement Specific Notes:

Note 1:	For emissions outside of the restricted bands the limit is -27dBm/MHz eirp (68.3dBuV/m). The measurement method required is a peak measurement (RB=1MHz, VB \geq 3MHz, peak detector). Per KDB 789033 2) c) (i), compliance can be demonstrated by meeting the average and peak limits of 15.209, as an alternative.
Note 2:	Emission has duty cycle $\geq 98\%$, average measurement performed: RBW=1MHz, VBW=3MHz, RMS, Power averaging, auto sweep, trace average 100 traces
Note 3:	Emission has duty cycle $< 98\%$, but constant, average measurement performed: RBW=1MHz, VBW=10Hz, peak detector, linear averaging, auto sweep, trace average $100 * 1/DC$ traces, measurement corrected by Linear Voltage correction factor
Note 4:	Emission has duty cycle $< 98\%$ and is NOT constant, average measurement performed: RBW=1MHz, VBW $> 1/T$, peak detector, linear average mode, sweep time auto, max hold. Max hold for $50*(1/DC)$ traces
Note 5:	Emission has duty cycle $< 98\%$, but constant, average measurement performed: RBW=1MHz, VBW=3MHz, RMS, Power averaging, auto sweep, trace average $100 * 1/DC$ traces, measurement corrected by Pwr correction factor
Note 6:	Plots of the average and peak bandedge do not account for any duty cycle correction. Refer to the tabluar results for final measurements.

Client: Vivint Wireless	Job Number: J96375
Model: SR1430 (4x4 5GHz 802.11 master)	T-Log Number: T96435
	Project Manager: Christine Krebill
Contact: Venkat Kalkunte	Project Coordinator: -
Standard: FCC 15.B / 15.407 / 15.247 (Old Rules)	Class: N/A

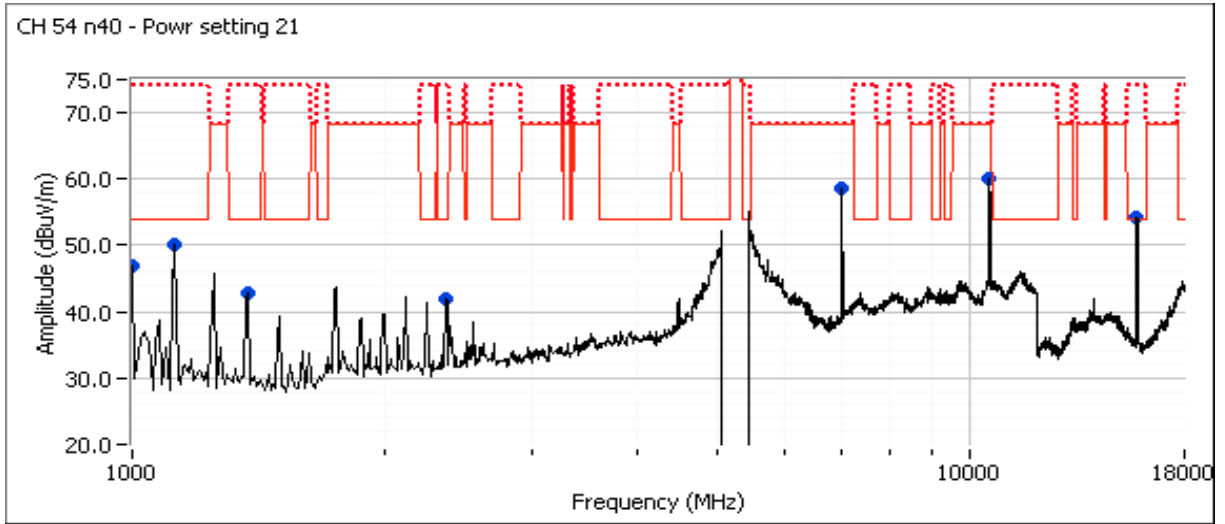

Client: Vivint Wireless	Job Number: J96375
Model: SR1430 (4x4 5GHz 802.11 master)	T-Log Number: T96435
	Project Manager: Christine Krebill
Contact: Venkat Kalkunte	Project Coordinator: -
Standard: FCC 15.B / 15.407 / 15.247 (Old Rules)	Class: N/A

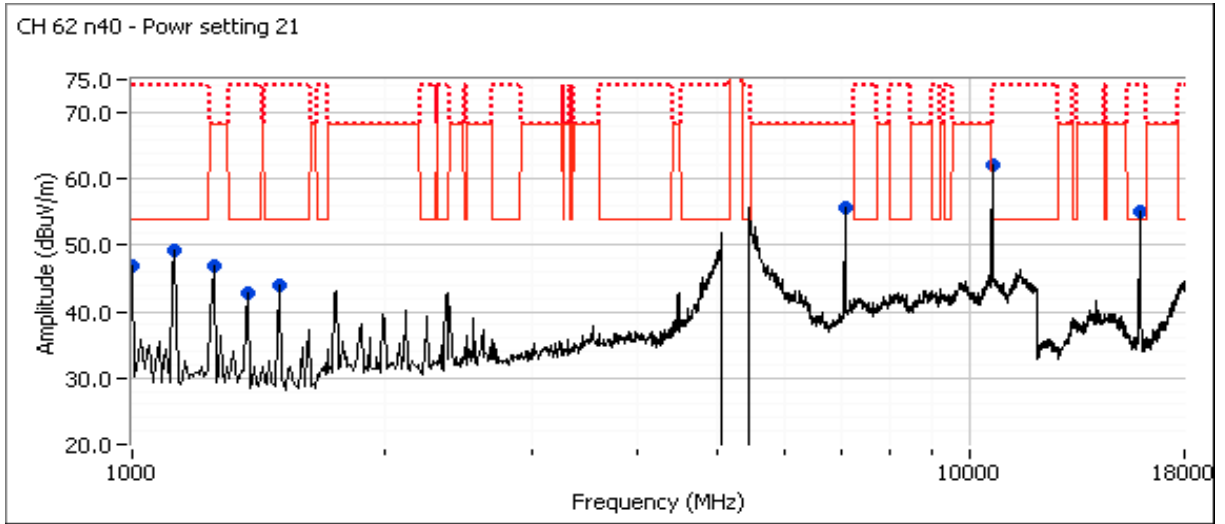

Client: Vivint Wireless	Job Number: J96375
Model: SR1430 (4x4 5GHz 802.11 master)	T-Log Number: T96435
	Project Manager: Christine Krebill
Contact: Venkat Kalkunte	Project Coordinator: -
Standard: FCC 15.B / 15.407 / 15.247 (Old Rules)	Class: N/A

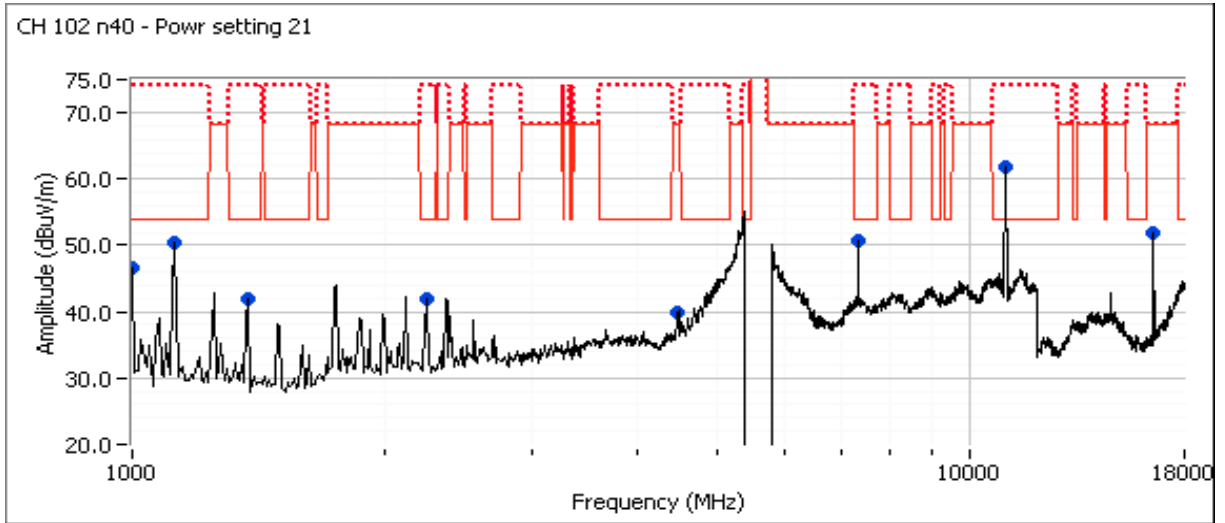



EMC Test Data

Client: Vivint Wireless	Job Number: J96375
Model: SR1430 (4x4 5GHz 802.11 master)	T-Log Number: T96435
	Project Manager: Christine Krebill
Contact: Venkat Kalkunte	Project Coordinator: -
Standard: FCC 15.B / 15.407 / 15.247 (Old Rules)	Class: N/A

Run #3b:

Channel: 110 Mode: n40 Power Setting: 21
 Tx Chain: 4Tx Data Rate: MCS8

Frequency MHz	Level dB μ V/m	Pol v/h	15.209 / 15E		Detector Pk/QP/Avg	Azimuth degrees	Height meters	Comments
			Limit	Margin				
11098.730	53.2	V	54.0	-0.8	AVG	227	2.2	RB 1 MHz;VB 10 Hz;Peak
11100.200	65.4	V	74.0	-8.6	PK	227	2.2	RB 1 MHz;VB 3 MHz;Peak
7400.150	50.3	V	54.0	-3.7	AVG	57	2.5	RB 1 MHz;VB 10 Hz;Peak
7400.230	56.1	V	74.0	-17.9	PK	57	2.5	RB 1 MHz;VB 3 MHz;Peak
1125.100	50.1	H	54.0	-3.9	AVG	248	1.5	RB 1 MHz;VB 10 Hz;Peak
1124.830	56.4	H	74.0	-17.6	PK	248	1.5	RB 1 MHz;VB 3 MHz;Peak
1000.000	46.3	H	54.0	-7.7	AVG	250	1.9	RB 1 MHz;VB 10 Hz;Peak
1000.060	48.8	H	74.0	-25.2	PK	250	1.9	RB 1 MHz;VB 3 MHz;Peak
1375.180	41.5	H	54.0	-12.5	AVG	300	2.5	RB 1 MHz;VB 10 Hz;Peak
1375.220	48.3	H	74.0	-25.7	PK	300	2.5	RB 1 MHz;VB 3 MHz;Peak
2240.100	36.4	H	54.0	-17.6	AVG	237	2.3	RB 1 MHz;VB 10 Hz;Peak
2239.920	43.9	H	74.0	-30.1	PK	237	2.3	RB 1 MHz;VB 3 MHz;Peak
16640.000	46.6	H	68.3	-21.7	Peak	259	1.6	
22200.420	45.2	V	54.0	-8.8	AVG	264	2.1	RB 1 MHz;VB 10 Hz;Peak
22202.480	58.3	V	74.0	-15.7	PK	264	2.1	RB 1 MHz;VB 3 MHz;Peak
22200.380	45.2	H	54.0	-8.8	AVG	291	2.1	RB 1 MHz;VB 10 Hz;Peak
22196.320	55.7	H	74.0	-18.3	PK	291	2.1	RB 1 MHz;VB 3 MHz;Peak
27749.120	57.6	V	68.3	-10.7	PK	273	1.5	RB 1 MHz;VB 3 MHz;Peak
27749.600	58.4	H	68.3	-9.9	PK	258	1.6	RB 1 MHz;VB 3 MHz;Peak

Note:	Scans made between 18 - 40 GHz with the measurement antenna moved around the card and its antennas 20-50cm from the device indicated there were no significant emissions in this frequency range
Note 1:	For emissions in restricted bands, the limit of 15.209 was used which requires average and peak measurements.
Note 2:	For emissions outside of the restricted bands the limit is -27dBm/MHz eirp (68.3dBuV/m). The measurement method required is a peak measurement (RB=1MHz, VB≥3MHz, peak detector).

Client: Vivint Wireless	Job Number: J96375
Model: SR1430 (4x4 5GHz 802.11 master)	T-Log Number: T96435
	Project Manager: Christine Krebill
Contact: Venkat Kalkunte	Project Coordinator: -
Standard: FCC 15.B / 15.407 / 15.247 (Old Rules)	Class: N/A

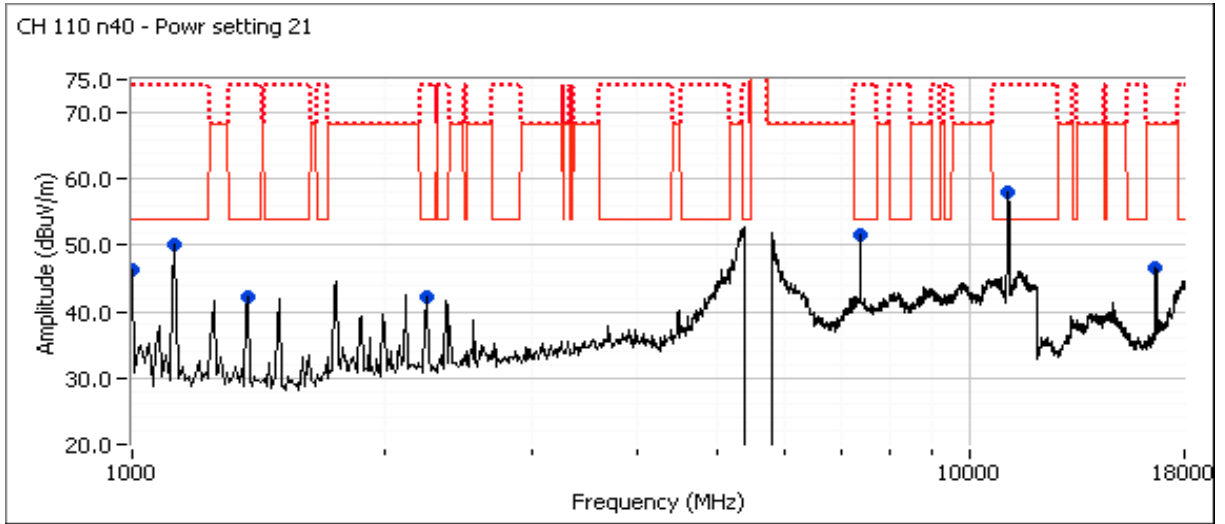



EMC Test Data

Client: Vivint Wireless	Job Number: J96375
Model: SR1430 (4x4 5GHz 802.11 master)	T-Log Number: T96435
	Project Manager: Christine Krebill
Contact: Venkat Kalkunte	Project Coordinator: -
Standard: FCC 15.B / 15.407 / 15.247 (Old Rules)	Class: N/A

Run #3c:

Channel: 142 Mode: n40 Power Setting: 21
 Tx Chain: 4Tx Data Rate: MCS8

Frequency MHz	Level dB μ V/m	Pol v/h	15.209 / 15E		Detector Pk/QP/Avg	Azimuth degrees	Height meters	Comments
			Limit	Margin				
22840.680	50.4	H	54.0	-3.6	AVG	203	1.5	RB 1 MHz;VB 10 Hz;Peak
22841.050	62.5	H	74.0	-11.5	PK	203	1.5	RB 1 MHz;VB 3 MHz;Peak
3806.830	39.6	V	54.0	-14.4	AVG	73	1.9	RB 1 MHz;VB 10 Hz;Peak
3806.380	48.5	V	74.0	-25.5	PK	73	1.9	RB 1 MHz;VB 3 MHz;Peak
11416.930	48.1	V	54.0	-5.9	AVG	210	2.0	RB 1 MHz;VB 10 Hz;Peak
11418.870	61.1	V	74.0	-12.9	PK	210	2.0	RB 1 MHz;VB 3 MHz;Peak
7613.450	48.1	V	54.0	-5.9	AVG	224	2.5	RB 1 MHz;VB 10 Hz;Peak
7613.780	54.8	V	74.0	-19.2	PK	224	2.5	RB 1 MHz;VB 3 MHz;Peak
1125.110	47.4	V	54.0	-6.6	AVG	239	1.3	RB 1 MHz;VB 10 Hz;Peak
1125.620	51.6	V	74.0	-22.4	PK	239	1.3	RB 1 MHz;VB 3 MHz;Peak
1000.030	43.5	V	54.0	-10.5	AVG	257	1.2	RB 1 MHz;VB 10 Hz;Peak
1000.020	45.3	V	74.0	-28.7	PK	257	1.2	RB 1 MHz;VB 3 MHz;Peak
2250.100	39.8	H	54.0	-14.2	AVG	322	2.5	RB 1 MHz;VB 10 Hz;Peak
2250.000	44.7	H	74.0	-29.3	PK	322	2.5	RB 1 MHz;VB 3 MHz;Peak
17110.000	48.1	H	68.3	-20.2	Peak	242	1.6	
22840.520	44.0	V	54.0	-10.0	AVG	294	0.9	RB 1 MHz;VB 10 Hz;Peak
22838.650	56.5	V	74.0	-17.5	PK	294	0.9	RB 1 MHz;VB 3 MHz;Peak
28553.430	58.3	V	68.3	-10.0	PK	228	1.8	RB 1 MHz;VB 3 MHz;Peak
28548.150	59.3	H	68.3	-9.0	PK	223	1.3	RB 1 MHz;VB 3 MHz;Peak

- Note: Scans made between 18 - 40 GHz with the measurement antenna moved around the card and its antennas 20-50cm from the device indicated there were no significant emissions in this frequency range
- Note 1: For emissions in restricted bands, the limit of 15.209 was used which requires average and peak measurements.
- Note 2: For emissions outside of the restricted bands the limit is -27dBm/MHz eirp (68.3dBuV/m). The measurement method

Client: Vivint Wireless	Job Number: J96375
Model: SR1430 (4x4 5GHz 802.11 master)	T-Log Number: T96435
	Project Manager: Christine Krebill
Contact: Venkat Kalkunte	Project Coordinator: -
Standard: FCC 15.B / 15.407 / 15.247 (Old Rules)	Class: N/A

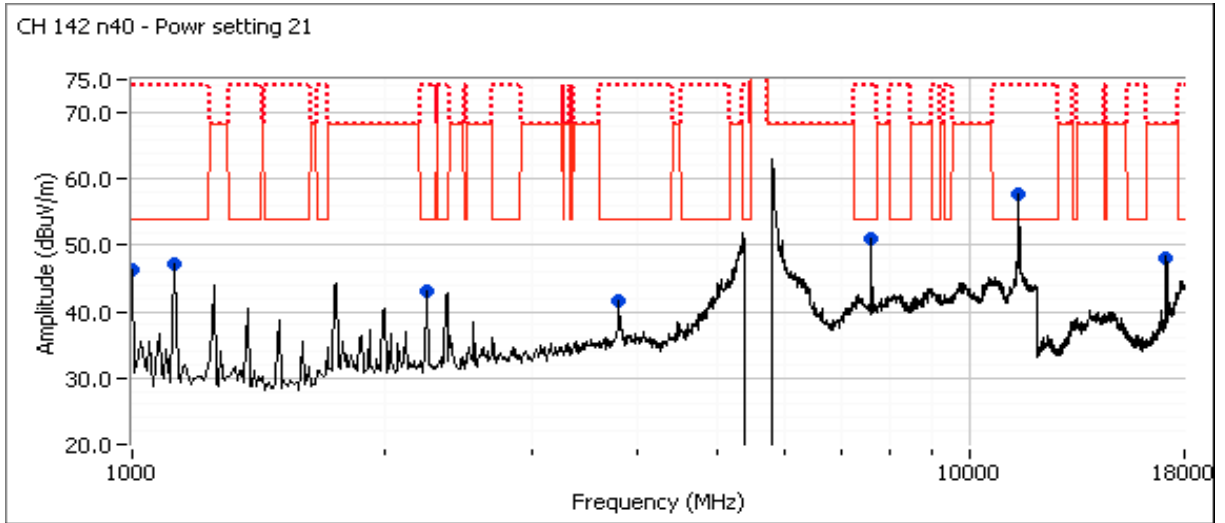

Client:	Vivint Wireless	Job Number:	J96375
Model:	SR1430 (4x4 5GHz 802.11 master)	T-Log Number:	T96435
		Project Manager:	Christine Krebill
Contact:	Venkat Kalkunte	Project Coordinator:	-
Standard:	FCC 15.B / 15.407 / 15.247 (Old Rules)	Class:	N/A

RSS-210 (LELAN) and FCC 15.407(UNII) Antenna Port Measurements Power, PSD, Peak Excursion, Bandwidth and Spurious Emissions

Test Specific Details

Objective: The objective of this test session is to perform final qualification testing of the EUT with respect to the specification listed above.

Summary of Results

Run #	Test Performed	Limit	Pass / Fail	Result / Margin
1	Power, 5250 - 5350MHz	15.407(a) (1), (2)	Pass	n40: 85.5mW
1	PSD, 5250 - 5350MHz	15.407(a) (1), (2)	Pass	n40: 3.1 dBm/MHz
1	Max EIRP 5250 - 5350MHz	TPC required if EIRP ≥ 500mW (27dBm). EIRP ≥ 200mW (23dBm) DFS threshold = -64dBm.	Pass	EIRP = 26.81dBm (480.66 mW)
1	Power, 5470 - 5725MHz	15.407(a) (1), (2)	Pass	n40: 157.3mW
1	PSD, 5470 - 5725MHz	15.407(a) (1), (2)	Pass	n40: 6.2 dBm/MHz
1	Max EIRP 5470 - 5725MHz	TPC required if EIRP ≥ 500mW (27dBm). EIRP ≥ 200mW (23dBm) DFS threshold	Pass	EIRP = 29.96 dBm (992.4 mW)
1	26dB Bandwidth	15.407 (Information only)	-	> 20MHz for all modes
1	99% Bandwidth	RSS 210 (Information only)	N/A	n40: 36.47 MHz
2	Peak Excursion Envelope	15.407(a) (6) 13dB	Pass	9.69
3	Antenna Conducted - Out of Band Spurious	15.407(b) -27dBm/MHz	N/A	Testing Performed Radiated



EMC Test Data

Client: Vivint Wireless	Job Number: J96375
Model: SR1430 (4x4 5GHz 802.11 master)	T-Log Number: T96435
	Project Manager: Christine Krebill
Contact: Venkat Kalkunte	Project Coordinator: -
Standard: FCC 15.B / 15.407 / 15.247 (Old Rules)	Class: N/A

General Test Configuration

When measuring the conducted emissions from the EUT's antenna port, the antenna port of the EUT was connected to the spectrum analyzer or power meter via a suitable attenuator to prevent overloading the measurement system. All measurements are corrected to allow for the external attenuators and cables used.

Ambient Conditions:

Temperature: 24 °C
 Rel. Humidity: 40 %

Modifications Made During Testing

No modifications were made to the EUT during testing

Deviations From The Standard

No deviations were made from the requirements of the standard.

Procedure Comments:

Measurements performed in accordance with FCC KDB 789033 D01 v01r03, dated April 8, 2013

Mode	Data Rate	Duty Cycle (x)	Constant DC?	T (ms)	Pwr Cor Factor*	Lin Volt Cor Factor**	Min VBW for FS (Hz)
n40	MCS8	93.0%	Yes	1.29	0.31	0.63	775

Note:

1. Antenna port number defined
 Port JE09 -Test port 0 ; Port JE10 -Test port 1 ; Port JE11 -Test port 2 ; Port JE12 -Test port 3
2. All the measurements measured at the end of the internal cable, not the output on the PCB board.

Sample Notes

Sample S/N: C7105S11304001R
 Driver: -



EMC Test Data

Client: Vivint Wireless	Job Number: J96375
Model: SR1430 (4x4 5GHz 802.11 master)	T-Log Number: T96435
	Project Manager: Christine Krebill
Contact: Venkat Kalkunte	Project Coordinator: -
Standard: FCC 15.B / 15.407 / 15.247 (Old Rules)	Class: N/A

Run #1: Bandwidth, Output Power and Power Spectral Density - MIMO Systems
 Date of Test: 10/14/14, 10/15/14, 11/4/14 Config. Used: 1
 Test Engineer: Jack Liu Config Change: None
 Test Location: FT Lab 4B EUT Voltage: PoE

- Note 1: Output power measured using a spectrum analyzer (see plots below). RBW=1MHz, VB=3 MHz, # of points in sweep $\geq 2 \times \text{span} / \text{RBW}$, Sample or RMS detector, power averaging on and power integration and adjusted for duty cycle. (method SA-2 of KDB 789033).
- Note 2: Measured using the same analyzer settings used for output power.
- Note 3: For RSS-210 the limit for the 5150 - 5250 MHz band accounts for the antenna gain as the maximum eirp allowed is 10dBm/MHz. The limits are also corrected for instances where the highest measured value of the PSD exceeds the average PSD (calculated from the measured power divided by the measured 99% bandwidth) by more than 3dB by the amount that the measured value exceeds the average by more than 3dB.
- Note 4: 99% Bandwidth measured in accordance with RSS GEN - RB > 1% of span and VB $\geq 3 \times \text{RB}$
- Note 5: For MIMO systems the total output power and total PSD are calculated from the sum of the powers of the individual chains (in linear terms). The antenna gain used to determine the EIRP and limits for PSD/Output power depends on the operating mode of the MIMO device. If the signals are non-coherent between the transmit chains then the gain used to determine the limits is the highest gain of the individual chains and the EIRP is the sum of the products of gain and power on each chain. If the signals are coherent then the effective antenna gain is the sum (in linear terms) of the gains for each chain and the EIRP is the product of the effective gain and total power.

Antenna Gain Information

Freq	Antenna Gain (dBi) / Chain				BF	MultiChain Legacy	CDD	Sectorized / Xpol	Dir G (PWR)	Dir G (PSD)
	1	2	3	4						
5150-5250	4	4	4	4	Yes	No	Yes	No	7.00	7.00
5250-5350	4.5	4.5	4.5	4.5	Yes	No	Yes	No	7.50	7.50
5470-5725	5	5	5	5	Yes	No	Yes	No	8.00	8.00
5725-5825	5.5	5.5	5.5	5.5	Yes	No	Yes	No	8.50	8.50

Antenna gain based on stated with 5dB of attenuation. Measurements performed at the end of the cables from the radio module, prior to the attenuators



EMC Test Data

Client:	Vivint Wireless	Job Number:	J96375
Model:	SR1430 (4x4 5GHz 802.11 master)	T-Log Number:	T96435
		Project Manager:	Christine Krebill
Contact:	Venkat Kalkunte	Project Coordinator:	-
Standard:	FCC 15.B / 15.407 / 15.247 (Old Rules)	Class:	N/A

For devices that support CDD modes

Min # of spatial streams: 2
 Max # of spatial streams: 4

Notes:	BF = beamforming mode supported, Multichain Legacy = 802.11 legacy data rates supported for multichain transmissions, CDD = Cyclic Delay Diversity (or Cyclic Shift Diversity) modes supported, Sectorized / Xpol = antennas are sectorized or cross polarized.
Notes:	Dir G (PWR) = total gain (Gant + Array Gain) for power calculations; GA (PSD) = total gain for PSD calculations based on FCC KDB 662911. Depending on the modes supported, the Array Gain value for power could be different from the PSD value.
Notes:	Array gain for power/psd calculated per DKB 662911 D01, v01r02. Spatial Multiplexing with Nant=4, Nss=2, for worse case condition. Array gain = $10 \cdot \log(4/2) = 3\text{dB}$.
Notes:	For systems with Beamforming and CDD, choose one the following options: Option 1: Delays are optimized for beamforming, rather than being selected from cyclic delay table of 802.11; Array gains calculated based on beamforming criteria. Option 2: Antennas are paired for beamforming, and the pairs are configured to use the cyclic delay diversity of 802.11; the array gain associated with beamforming with 2 antennas (3dB), and the array gain associated with CDD with two antennas (3dB for PSD and 0 dB for power)



EMC Test Data

Client: Vivint Wireless	Job Number: J96375
Model: SR1430 (4x4 5GHz 802.11 master)	T-Log Number: T96435
	Project Manager: Christine Krebill
Contact: Venkat Kalkunte	Project Coordinator: -
Standard: FCC 15.B / 15.407 / 15.247 (Old Rules)	Class: N/A

MIMO Device - 5250-5350 MHz Band - FCC

Mode: n40

Max EIRP (mW): 480.6633

Frequency (MHz)	Chain	Software Setting	26dB BW (MHz)	Duty Cycle %	Power dBm	Total Power ¹ mW	Total Power ¹ dBm	FCC Limit dBm	Max Power (W)	Result
5310	1	13	43.0	93	13.1	85.5	19.3	22.5	0.085	Pass
	3				12.6					
	4				12.7					
	2				13.5					

MIMO Device 5250-5350 PSD - FCC/IC

Mode: n40

Frequency (MHz)	Chain	Software Setting	99% BW (MHz)	Duty Cycle %	PSD dBm/MHz	Total PSD ¹ mW/MHz	Total PSD ¹ dBm/MHz	FCC Limit dBm/MHz	IC Limit dBm/MHz	Result
5310	1	13	36.4	93	-3.2	2.0	3.1	9.5	-	Pass
	3				-3.6					
	4				-3.5					
	2				-2.7					

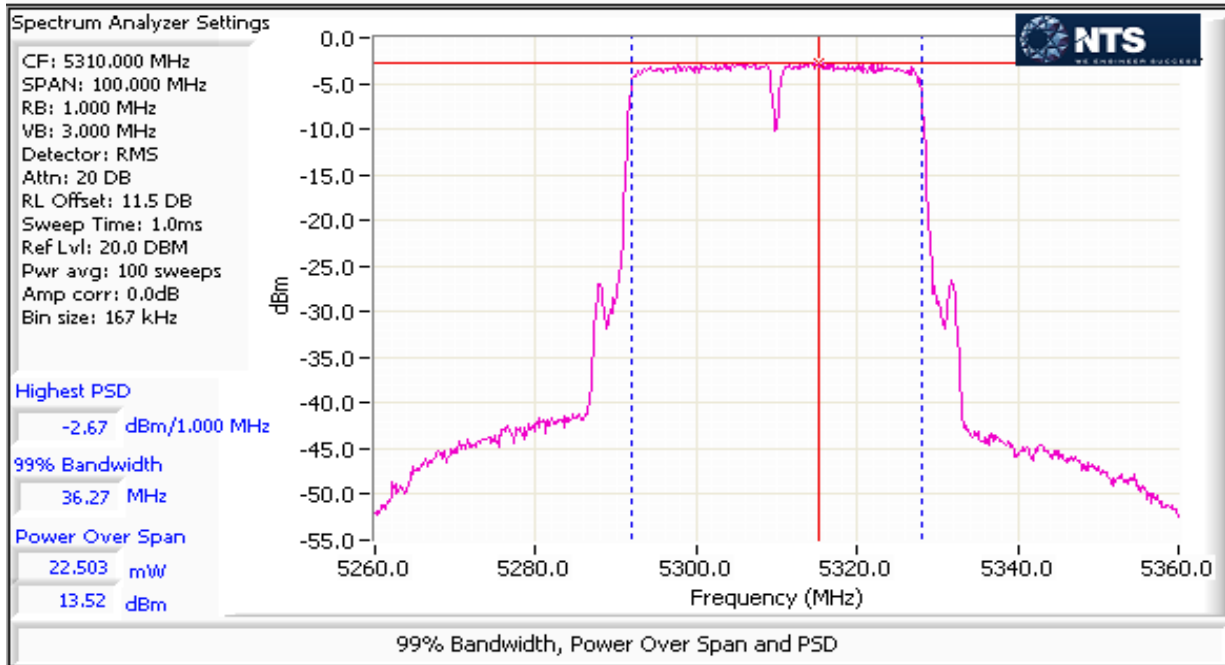

Client: Vivint Wireless	Job Number: J96375
Model: SR1430 (4x4 5GHz 802.11 master)	T-Log Number: T96435
Contact: Venkat Kalkunte	Project Manager: Christine Krebill
Standard: FCC 15.B / 15.407 / 15.247 (Old Rules)	Project Coordinator: -
	Class: N/A

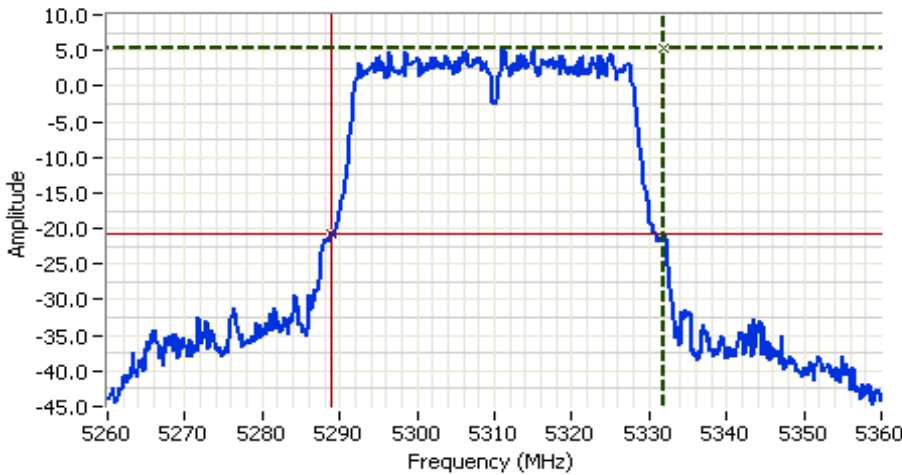

Analyzer Settings

Agilent Technologies, E4446A
 CF: 5310.000 MHz
 SPAN: 100.000 MHz
 RB: 510 kHz
 VB: 1.500 MHz
 Detector: POS
 Attn: 20 DB
 RL Offset: 11.5 DB
 Sweep Time: 1.0ms
 Ref Lvl: 20.0 DBM

Comments

26dB BW: 43.000 MHz
 CH62 n40
 pwr setting 13

Cursor 1	5331.8333	5.26	
Cursor 2	5288.8333	-20.74	

Delta Freq.	43.000
Delta Amplitude	26.00



EMC Test Data

Client: Vivint Wireless	Job Number: J96375
Model: SR1430 (4x4 5GHz 802.11 master)	T-Log Number: T96435
	Project Manager: Christine Krebill
Contact: Venkat Kalkunte	Project Coordinator: -
Standard: FCC 15.B / 15.407 / 15.247 (Old Rules)	Class: N/A

MIMO Device - 5470-5725 MHz Band - FCC
 Mode: n40 Max EIRP (mW): 992.34992

Frequency (MHz)	Chain	Software Setting	26dB BW (MHz)	Duty Cycle %	Power dBm	Total Power ¹ mW	FCC Limit dBm	Max Power (W)	Result
5510	0	12	42.5	93	10.9	62.3	17.9	0.157	Pass
	1				11.6				
	2				12.2				
	3				11.7				
5550	0	16	46.5	93	15.3	155.5	21.9		Pass
	1				15.4				
	2				15.8				
	3				15.8				
5670	0	16	43.0	93	15.1	147.2	21.7		Pass
	1				15.4				
	2				15.4				
	3				15.6				
802.11n 40MHz UNII-2ext									
5710	0	16	37.1	93	15.8	157.3	21.97	Pass	
	1				15.4				
	2				15.6				
	3				15.7				
UNII-3									
5710	0	16	9.8	93	5.7	15.6	11.9	Pass	
	1				4.9				
	2				5.8				
	3				5.9				



EMC Test Data

Client: Vivint Wireless	Job Number: J96375
Model: SR1430 (4x4 5GHz 802.11 master)	T-Log Number: T96435
	Project Manager: Christine Krebill
Contact: Venkat Kalkunte	Project Coordinator: -
Standard: FCC 15.B / 15.407 / 15.247 (Old Rules)	Class: N/A

MIMO Device 5470-5725 PSD - FCC/IC
Mode: n40

Frequency (MHz)	Chain	Software Setting	99% BW (MHz)	Duty Cycle %	PSD dBm/MHz	Total PSD ¹ mW/MHz	Total PSD ¹ dBm/MHz	FCC Limit dBm/MHz	IC Limit dBm/MHz	Result
5510	0	12	36.44	93	-5.3	1.5	1.8	9.0	-	Pass
	1				-4.5					
	2				-3.9					
	3				-4.5					
5550	0	16	36.47	93	-0.8	3.8	5.8	9.0	-	Pass
	1				-0.8					
	2				-0.4					
	3				-0.4					
5670	0	16	36.44	93	-1.0	3.6	5.5	9.0	-	Pass
	1				-0.8					
	2				-0.8					
	3				-0.6					

802.11n 40MHz

UNII-2ext

5710	0	18	33.22	93	0.1	4.2	6.2	9.0	-	Pass
	1				-0.4					
	2				-0.1					
	3				0.1					

UNII-3

5710	0	18	6.46	93	-0.1	4.1	6.1	8.5	-	Pass
	1				-0.9					
	2				0.0					
	3				0.0					

Client: Vivint Wireless	Job Number: J96375
Model: SR1430 (4x4 5GHz 802.11 master)	T-Log Number: T96435
	Project Manager: Christine Krebill
Contact: Venkat Kalkunte	Project Coordinator: -
Standard: FCC 15.B / 15.407 / 15.247 (Old Rules)	Class: N/A

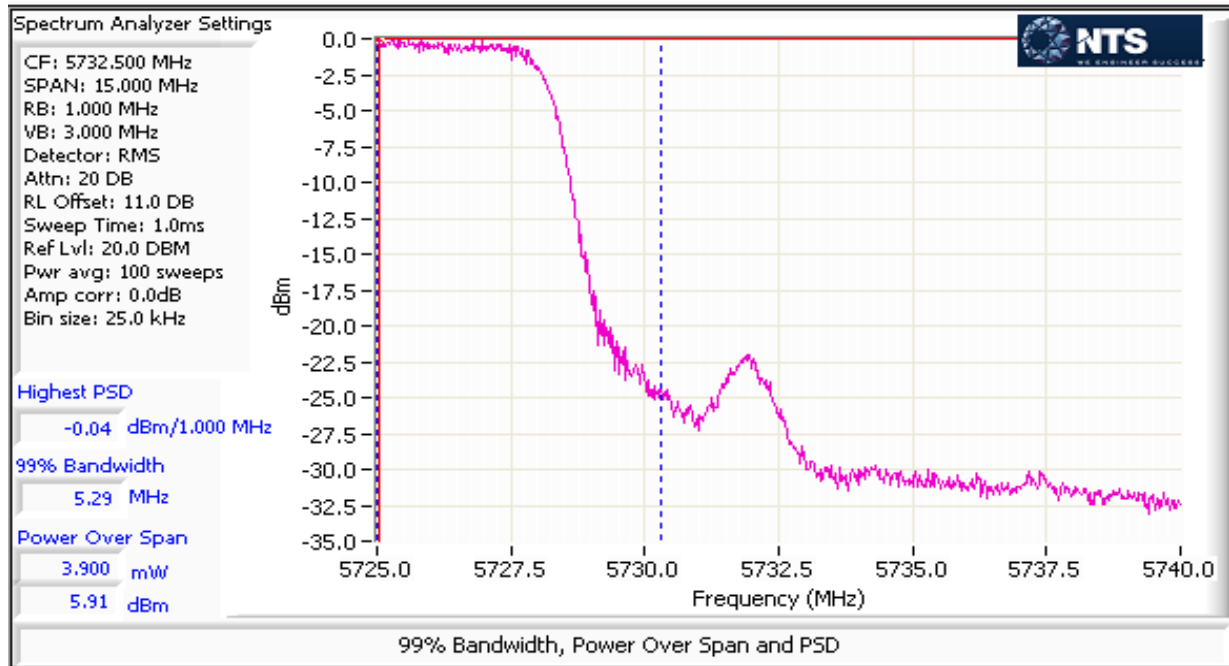
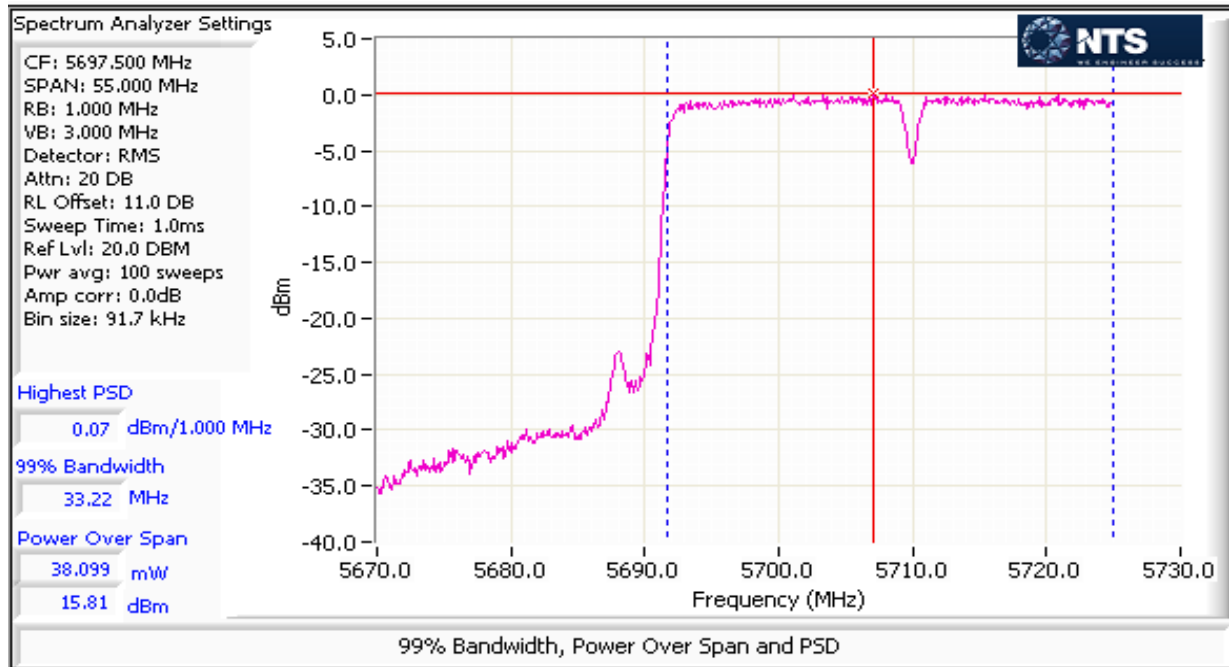

Client: Vivint Wireless	Job Number: J96375
Model: SR1430 (4x4 5GHz 802.11 master)	T-Log Number: T96435
	Project Manager: Christine Krebill
Contact: Venkat Kalkunte	Project Coordinator: -
Standard: FCC 15.B / 15.407 / 15.247 (Old Rules)	Class: N/A

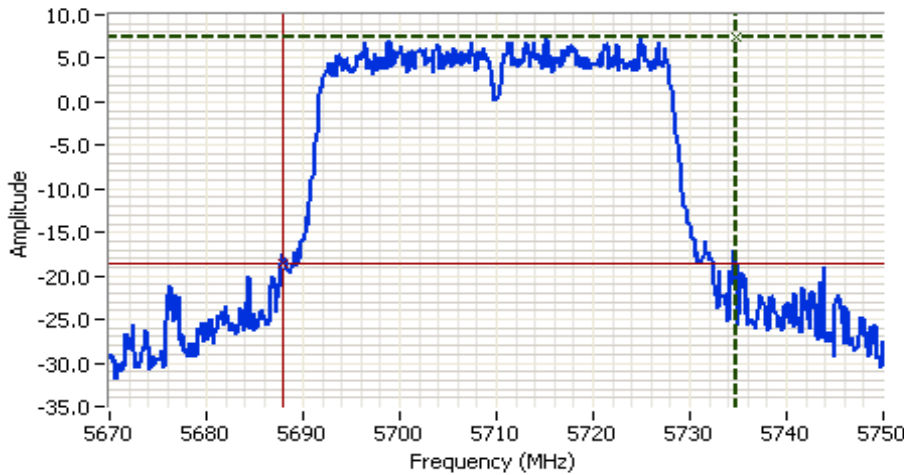

Analyzer Settings

Agilent Technologies, E4446A
 CF: 5710.000 MHz
 SPAN: 80.000 MHz
 RB: 510 kHz
 VB: 1.500 MHz
 Detector: POS
 Attn: 20 DB
 RL Offset: 11.0 DB
 Sweep Time: 1.0ms
 Ref Lvl: 20.0 DBM

Comments

26dB BW: 46.933 MHz
 UNII2-ext:37.13MHz
 UNII3:9.8MHz
 802.11 n40

Cursor 1	5734.8000	7.35	
Cursor 2	5687.8667	-18.65	

Delta Freq.	46.933
Delta Amplitude	26.00

Client: Vivint Wireless	Job Number: J96375
Model: SR1430 (4x4 5GHz 802.11 master)	T-Log Number: T96435
	Project Manager: Christine Krebill
Contact: Venkat Kalkunte	Project Coordinator: -
Standard: FCC 15.B / 15.407 / 15.247 (Old Rules)	Class: N/A

99% BW measurement for DFS testing

Mode: HT40
5470-5725 (UNII-2C)

Power Setting	Frequency (MHz)	Bandwidth (MHz)		RBW Setting (MHz)	
		6dB	99%	6dB	99%
18	5550	-	36.44	-	0.51

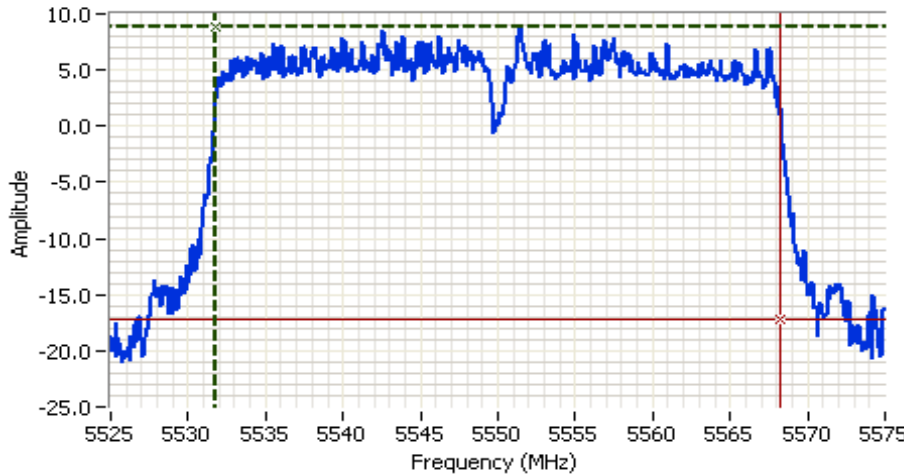

Analyzer Settings
 Agilent Technologies, E4446A
 CF: 5550.000 MHz
 SPAN: 50.000 MHz
 RB: 510 kHz
 VB: 1.500 MHz
 Detector: POS
 Attn: 20 DB
 RL Offset: 11.5 DB
 Sweep Time: 1.0ms
 Ref Lvl: 20.0 DBM

Comments
 99% power BW: 36.439 MHz
 CH110 n40
 pwr setting 18

Cursor 1	5531.7388	8.80	
Cursor 2	5568.1780	-17.20	

Delta Freq. 36.439
Delta Amplitude 26.00



Note 1: 99% BW: RBW=1-5% of of 99%BW, VBW ≥ 3*RBW, peak detector, max hold, auto sweep time.



EMC Test Data

Client: Vivint Wireless	Job Number: J96375
Model: SR1430 (4x4 5GHz 802.11 master)	T-Log Number: T96435
	Project Manager: Christine Krebill
Contact: Venkat Kalkunte	Project Coordinator: -
Standard: FCC 15.B / 15.407 / 15.247 (Old Rules)	Class: N/A

Run #2: Peak Excursion Measurement

Date of Test: 10/14/2014, 10/15/14, 11/4/14 Config. Used: 1
 Test Engineer: Jack Liu Config Change: None
 Test Location: FT Lab 4B EUT Voltage: PoE

40MHz: Device meets the requirement for the peak excursion

Freq	Peak Excursion(dB)		Freq	Peak Excursion(dB)	
(MHz)	Value	Limit	(MHz)	Value	Limit
5310	9.6	13.0	5510	9.1	13.0
			5550	9.5	13.0
			5670	9.7	13.0
			5710	9.4	13.0

Plots Showing Peak Excursion

Trace A: RBW = 1MHz, VBW = 3MHz, Peak hold
 Trace B: Same settings as used for power/PSD measurements (RBW = 1 MHz, VBW = 3MHz, Integrated average power)

Client: Vivint Wireless	Job Number: J96375
Model: SR1430 (4x4 5GHz 802.11 master)	T-Log Number: T96435
Contact: Venkat Kalkunte	Project Manager: Christine Krebill
Standard: FCC 15.B / 15.407 / 15.247 (Old Rules)	Project Coordinator: -
	Class: N/A

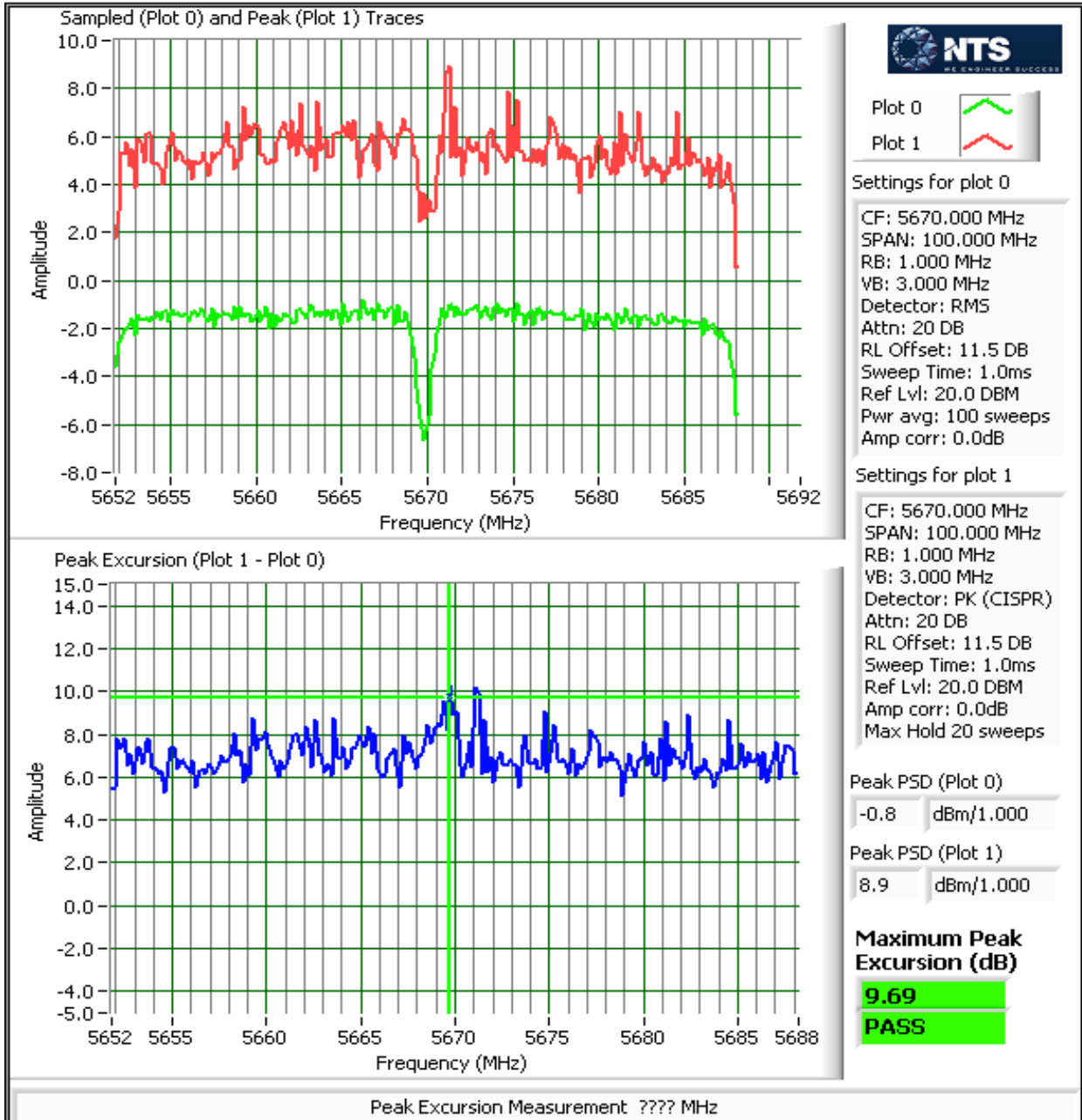



EMC Test Data

Client: Vivint Wireless	Job Number: J96375
Model: SR1430 (4x4 5GHz 802.11 master)	T-Log Number: T96435
	Project Manager: Christine Krebill
Contact: Venkat Kalkunte	Project Coordinator: -
Standard: FCC 15.B / 15.407 / 15.247 (Old Rules)	Class: A

Conducted Emissions

(Elliott Laboratories Fremont Facility, Semi-Anechoic Chamber)

Test Specific Details

Objective: The objective of this test session is to perform final qualification testing of the EUT with respect to the specification listed above.

Date of Test: 8/20/2014	Config. Used: 1
Test Engineer: Jack Liu	Config Change: None
Test Location: Fremont Chamber #4	EUT Voltage: PoE

General Test Configuration

For tabletop equipment, the EUT was located on a wooden table inside the semi-anechoic chamber, 40 cm from a vertical coupling plane and 80cm from the LISN. A second LISN was used for all local support equipment. Remote support equipment was located outside of the semi-anechoic chamber. Any cables running to remote support equipment were routed through metal conduit and when possible passed through a ferrite clamp upon exiting the chamber.

Ambient Conditions:	Temperature:	24 °C
	Rel. Humidity:	38 %

Summary of Results

Run #	Test Performed	Limit	Result	Margin
1	CE, AC Power, 120V/60Hz	15.207	Pass	60.0 dBµV @ 0.151 MHz (-5.9 dB)

Modifications Made During Testing

FerriShield (www.leadertechinc.com) - cable clamp TC28B0617; placed on the ethernet cable between external port and internal pcb

Deviations From The Standard

No deviations were made from the requirements of the standard.

Client: Vivint Wireless	Job Number: J96375
Model: SR1430 (4x4 5GHz 802.11 master)	T-Log Number: T96435
	Project Manager: Christine Krebill
Contact: Venkat Kalkunte	Project Coordinator: -
Standard: FCC 15.B / 15.407 / 15.247 (Old Rules)	Class: A

Run #1: AC Power Port Conducted Emissions, 0.15 - 30MHz, 120V/60Hz
 EUT transmitting on channel 134 at power setting 18.

Plots show FCC 15.107 Class A limits - Tabular data compared to 15.207 limits

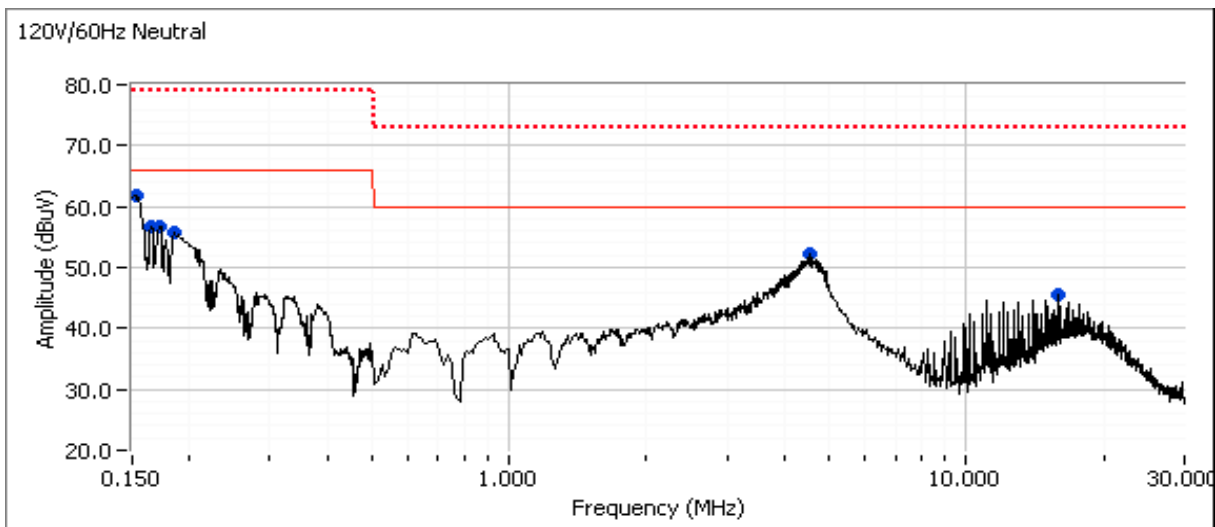
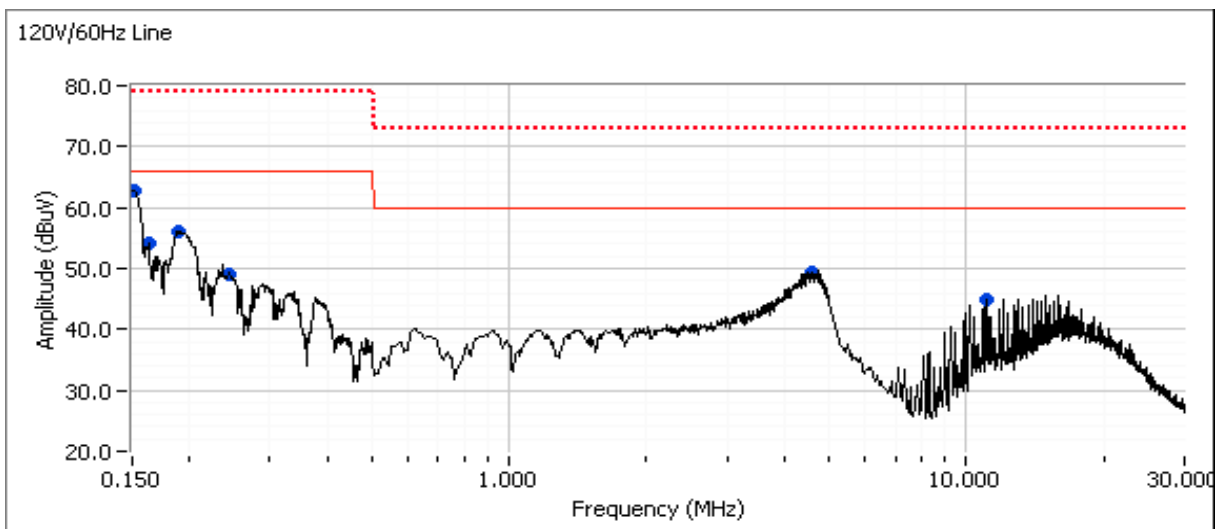



EMC Test Data

Client: Vivint Wireless	Job Number: J96375
Model: SR1430 (4x4 5GHz 802.11 master)	T-Log Number: T96435
	Project Manager: Christine Krebill
Contact: Venkat Kalkunte	Project Coordinator: -
Standard: FCC 15.B / 15.407 / 15.247 (Old Rules)	Class: A

Preliminary peak readings captured during pre-scan (peak readings vs. average limit)

Frequency MHz	Level dB μ V	AC Line	15.207		Detector QP/Ave	Comments
			Limit	Margin		
11.114	45.0	Line	50.0	-5.0	Average	
4.617	49.3	Line	46.0	3.3	Average	
0.151	62.8	Line	56.0	6.8	Average	
0.190	56.0	Line	54.0	2.0	Average	
0.244	49.2	Line	52.0	-2.8	Average	
0.162	54.1	Line	55.4	-1.3	Average	
0.153	61.8	Neutral	55.9	5.9	Average	
0.167	56.8	Neutral	55.1	1.7	Average	
0.172	56.6	Neutral	54.9	1.7	Average	
0.187	55.6	Neutral	54.2	1.4	Average	
4.551	52.2	Neutral	46.0	6.2	Average	
15.838	45.6	Neutral	50.0	-4.4	Average	

Final quasi-peak and average readings

Frequency MHz	Level dB μ V	AC Line	15.207		Detector QP/Ave	Comments
			Limit	Margin		
0.151	60.0	Line	65.9	-5.9	QP	QP (1.00s)
11.114	43.9	Line	50.0	-6.1	Average	AVG (0.10s)
4.551	39.3	Neutral	46.0	-6.7	Average	AVG (0.10s)
4.551	47.8	Neutral	56.0	-8.2	QP	QP (1.00s)
15.838	41.7	Neutral	50.0	-8.3	Average	AVG (0.10s)
0.153	57.3	Neutral	65.8	-8.5	QP	QP (1.00s)
4.617	36.4	Line	46.0	-9.6	Average	AVG (0.10s)
0.190	54.0	Line	64.0	-10.0	QP	QP (1.00s)
4.617	45.7	Line	56.0	-10.3	QP	QP (1.00s)
0.186	52.0	Neutral	64.2	-12.2	QP	QP (1.00s)
0.151	41.6	Line	55.9	-14.3	Average	AVG (0.10s)
0.190	39.3	Line	54.0	-14.7	Average	AVG (0.10s)
11.114	44.9	Line	60.0	-15.1	QP	QP (1.00s)
0.244	45.9	Line	62.0	-16.1	QP	QP (1.00s)
15.838	43.7	Neutral	60.0	-16.3	QP	QP (1.00s)
0.162	48.5	Line	65.4	-16.9	QP	QP (1.00s)
0.153	37.7	Neutral	55.8	-18.1	Average	AVG (0.10s)
0.186	34.5	Neutral	54.2	-19.7	Average	AVG (0.10s)
0.167	45.1	Neutral	65.1	-20.0	QP	QP (1.00s)
0.244	31.8	Line	52.0	-20.2	Average	AVG (0.10s)
0.172	44.4	Neutral	64.9	-20.5	QP	QP (1.00s)
0.162	24.7	Line	55.4	-30.7	Average	AVG (0.10s)
0.167	22.9	Neutral	55.1	-32.2	Average	AVG (0.10s)
0.172	22.5	Neutral	54.9	-32.4	Average	AVG (0.10s)

End of Report

This page is intentionally blank and marks the last page of this test report.