



FCC Test Report

Report No.: AGC01421140302FE08

FCC ID : 2AAA6-S1000
APPLICATION PURPOSE : Original Equipment
PRODUCT DESIGNATION : Smart mobile phone
BRAND NAME : Senwa
MODEL NAME : S1000
CLIENT : SENWA MEXICO,S.A.DE C.V
DATE OF ISSUE : Mar. 28, 2014
STANDARD(S) : FCC Part 15 Rules
REPORT VERSION : V1.0

Attestation of Global Compliance (Shenzhen) Co., Ltd



CAUTION:

This report shall not be reproduced except in full without the written permission of the test laboratory and shall not be quoted out of context.

Report Revise Record

| Report Version | Revise Time | Issued Date | Valid Version | Notes |
|----------------|-------------|---------------|---------------|-----------------|
| V1.0 | / | Mar. 28, 2014 | Valid | Original Report |

TABLE OF CONTENTS

| | |
|--|-----------|
| 1. VERIFICATION OF COMPLIANCE | 5 |
| 2. GENERAL INFORMATION | 6 |
| 2.1 PRODUCT DESCRIPTION | 6 |
| 2.2 RELATED SUBMITTAL(S)/GRANT(S)..... | 6 |
| 2.3 TEST METHODOLOGY | 6 |
| 2.4 TEST FACILITY..... | 6 |
| 2.5 SPECIAL ACCESSORIES..... | 6 |
| 2.6 EQUIPMENT MODIFICATIONS..... | 6 |
| 3. SYSTEM TEST CONFIGURATION | 7 |
| 3.1 CONFIGURATION OF TESTED SYSTEM | 7 |
| 3.2 EQUIPMENT USED IN TESTED SYSTEM | 7 |
| 4. SUMMARY OF TEST RESULTS | 8 |
| 5. DESCRIPTION OF TEST MODES | 8 |
| 6. ANTENNA REQUIREMENT | 9 |
| 6.1. STANDARD APPLICABLE | 9 |
| 6.2. TEST RESULT | 9 |
| 7. RADIATED EMISSION | 10 |
| 7.1 MEASUREMENT PROCEDURE | 10 |
| 7.2 TEST SETUP..... | 11 |
| 7.3 LIMITS AND MEASUREMENT RESULT | 12 |
| 7.4 TEST RESULT | 12 |
| 8. BAND EDGE EMISSION | 25 |
| 8.1. MEASUREMENT PROCEDURE | 25 |
| 8.2. TEST SET-UP | 25 |
| 8.3. TEST RESULT | 26 |
| 9. 6DB BANDWIDTH | 30 |
| 9.1. TEST EQUIPMENT LIST AND DETAILS..... | 30 |
| 9.2. TEST PROCEDURE..... | 30 |
| 9.3. SUMMARY OF TEST RESULTS/PLOTS | 30 |
| 10. CONDUCTED OUTPUT POWER | 33 |
| 10.1. MEASUREMENT PROCEDURE | 33 |
| 10.2. TEST SET-UP (BLOCK DIAGRAM OF CONFIGURATION)..... | 33 |
| 10.3. LIMITS AND MEASUREMENT RESULT | 33 |
| 11. MAXIMUM CONDUCTED OUTPUT POWER SPECTRAL DENSITY | 36 |
| 11.1 MEASUREMENT PROCEDURE | 36 |
| 11.2 TEST SET-UP (BLOCK DIAGRAM OF CONFIGURATION)..... | 36 |

11.3 MEASUREMENT EQUIPMENT USED 36

11.4 LIMITS AND MEASUREMENT RESULT 36

12. FCC LINE CONDUCTED EMISSION TEST 39

12.1 LIMITS 39

12.2 TEST SETUP 39

12.3 PRELIMINARY PROCEDURE 40

12.4 FINAL TEST PROCEDURE 40

12.5 TEST RESULT OF POWER LINE 41

APPENDIX A: PHOTOGRAPHS OF TEST SETUP 43

APPENDIX B: PHOTOGRAPHS OF EUT 44

1. VERIFICATION OF COMPLIANCE

| | |
|---------------------------------|---|
| Applicant | SENWA MEXICO,S.A.DE C.V |
| Address | Av. Javier Barros Sierra 540,Torre I, Planta 5; COL. LOMAS DE SANTA FE DELEGACION ALVARO OBREGON C.P. 01210 MEXICO,DISTRITO FEDERAL |
| Manufacturer | UNITED TIME TECHNOLOGY CO.,LTD. |
| Address | Room 1001 Microprofit Building,6 Gaoxin south Road, High-Tech Park, Nanshan district ,Shenzhen, P.R. China |
| Product Designation | Smart mobile phone |
| Brand Name | Senwa |
| Test Model | S1000 |
| Date of test | Mar. 12, 2014 to Mar. 25, 2014 |
| Deviation | None |
| Condition of Test Sample | Normal |
| Report Template | AGCRT-US-BLE/RF (2013-03-01) |

WE HEREBY CERTIFY THAT:

The above equipment was tested by Attestation of Global Compliance (Shenzhen) Co., Ltd. The test data, data evaluation, test procedures, and equipment configurations shown in this report were made in accordance with the procedures given in ANSI C63.4 (2003) and the energy emitted by the sample EUT tested as described in this report is in compliance with requirement of FCC Part 15 Rules requirement.

Prepared By



Wall Huang

Mar. 28, 2014

Checked By



Kidd Yang

Mar. 28, 2014

Authorized By



Solger Zhang

Mar. 28, 2014

2.GENERAL INFORMATION

2.1PRODUCT DESCRIPTION

The EUT is designed as a “**Smart mobile phone**”. It is designed by way of utilizing the FHSS technology to achieve the system operation.

A major technical description of EUT is described as following

| | |
|---------------------|--|
| Operation Frequency | 2.402 GHz to 2.480GHz |
| Bluetooth Version | V4.0 |
| Modulation | GFSK |
| Number of channels | 40 Channel(37 Hopping Channel,3 advertising Channel) |
| Antenna Designation | Integrated Antenna |
| Antenna Gain | 1.2dBi |
| Hardware Version | 13U57-V01 |
| Software Version | S50_13U57_1.23_ES_20140212 |
| Power Supply | DC3.7V by Built-in Li-ion Battery |

2.2 RELATED SUBMITTAL(S)/GRANT(S)

This submittal(s) (test report) is intended for **FCC ID: 2AAA6-S1000** filing to comply with Section 15.247of the FCC Part 15, Subpart C Rules.

2.3TEST METHODOLOGY

All measurements contained in this report were conducted with ANSI C63.4-2003, American National Standard for Methods of Measurement of Radio-Noise Emissions from Low-Voltage Electrical and Electronic Equipment in the range of 9 kHz to 40 GHz.

The equipment under test (EUT) was configured to measure its highest possible emission level. The test modes were adapted accordingly in reference to the Operating Instructions. The EUT was tested in all three orthogonal planes and the worse case was showed.

2.4 TEST FACILITY

All measurement facilities used to collect the measurement data are located at Attestation of Global Compliance (Shenzhen) Co, Ltd

2/F., Building 2, No.1-No.4, Chaxi Sanwei Technical Industrial Park, Gushu, Xixiang, Bao'an District, Shenzhen, Guangdong, China.

FCC register No.: 259865

2.5 SPECIAL ACCESSORIES

Refer to section 2.2.

2.6 EQUIPMENT MODIFICATIONS

Not available for this EUT intended for grant.

3. SYSTEM TEST CONFIGURATION

3.1 CONFIGURATION OF TESTED SYSTEM

Configuration:

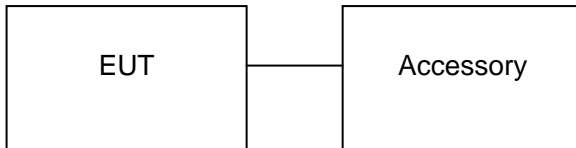

3.2 EQUIPMENT USED IN TESTED SYSTEM

| Item | Equipment | Model No. | ID or Specification | Note |
|------|--------------------|-----------|---------------------|-----------|
| 1 | Smart mobile phone | S1000 | FCC ID: 2AAA6-S1000 | EUT |
| 2 | Adapter | S1000 | DC5.0V / 1A | Accessory |
| 3 | Battery | S1000 | DC3.7V/ 2750 mAh | Accessory |
| 4 | Earphone | S1000 | N/A | Accessory |
| 5 | USB Cable | S1000 | N/A | Accessory |

ALL TEST EQUIPMENT LIST

| Description | Manufacturer | Model | S/N | Cal. Date | Cal. Due |
|--------------------|-------------------|-------------|------------|------------|------------|
| Power Probe | R&S | NRP-Z23 | 100323 | 07/17/2013 | 07/16/2014 |
| RF attenuator | N/A | RFA20db | 68 | N/A | N/A |
| Spectrum Analyzer | Agilent | E4440A | US41421290 | 07/17/2013 | 07/16/2014 |
| Amplifier | EM | EM30180 | 0607030 | 02/27/2014 | 02/26/2015 |
| Horn Antenna | EM | EM-AH-10180 | 67 | 04/21/2013 | 04/20/2014 |
| Horn Antenna | A.H. Systems Inc. | SAS-574 | -- | 07/17/2013 | 07/16/2014 |
| EMI Test Receiver | Rohde & Schwarz | ESCI | 100694 | 07/17/2013 | 07/16/2014 |
| Biological Antenna | A.H. Systems Inc. | SAS-521-4 | 26 | 06/07/2013 | 06/06/2014 |
| Loop Antenna | A.H. | SAS-526B | 264 | 07/14/2013 | 07/13/2014 |
| LISN | R&S | ESH3-Z5 | 8389791009 | 07/17/2013 | 07/16/2014 |

4. SUMMARY OF TEST RESULTS

| FCC RULES | DESCRIPTION OF TEST | RESULT |
|-----------------------|---|-----------|
| § 15.203 | Antenna Requirement | Compliant |
| §15.209 §15.247(d) | Radiated Emission | Compliant |
| §15.247(d) | Band Edges | Compliant |
| §15.247 | 6 dB Bandwidth | Compliant |
| §15.247(b) | Conducted Power | Compliant |
| §15.247(e) | Maximum Conducted Output Power SPECTRAL Density | Compliant |
| §15.207 | Line Conduction Emission | Compliant |

5. DESCRIPTION OF TEST MODES

The EUT has been operated in three modulations: GFSK independently.

| NO. | TEST MODE DESCRIPTION |
|-----|-----------------------|
| 1 | Low channel TX |
| 2 | Middle channel TX |
| 3 | High channel TX |
| 4 | Normal Operating (BT) |

Note:

- All the test modes can be supply by Built-in Li-ion battery, only the result of the worst case was recorded in the report if no any records.
- For Radiated Emission, 3axis were chosen for testing for each applicable mode.

6. ANTENNA REQUIREMENT

6.1. STANDARD APPLICABLE

According to FCC 15.203, An intentional radiator shall be designed to ensure that no antenna other than that furnished by the responsible party shall be used with the device. The use of a permanently attached antenna or of an antenna that uses a unique coupling to the intentional radiator shall be considered sufficient to comply with the provisions of this Section. The manufacturer may design the unit so that a broken antenna can be replaced by the user, but the use of a standard antenna jack or electrical connector is prohibited. This requirement does not apply to carrier current devices or to devices operated under the provisions of Sections 15.211, 15.213, 15.217, 15.219, or 15.221. Further, this requirement does not apply to intentional radiators that must be professionally installed, such as perimeter protection systems and some field disturbance sensors, or to other intentional radiators which, in accordance with Section 15.31(d), must be measured at the installation site. However, the installer shall be responsible for ensuring that the proper antenna is employed so that the limits in this Part are not exceeded.

6.2. TEST RESULT

This product has a permanent antenna, fulfill the requirement of this section.

7. RADIATED EMISSION

7.1 MEASUREMENT PROCEDURE

1. Configure the EUT according to ANSI C63.4. The EUT was placed on the top of the turntable 0.8 meter above ground. The phase center of the receiving antenna mounted on the top of a height-variable antenna tower was placed 3 meters far away from the turntable.
2. Power on the EUT and all the supporting units. The turntable was rotated by 360 degrees to determine the position of the highest radiation.
3. The height of the broadband receiving antenna was varied between one meter and four meters above ground to find the maximum emissions field strength of both horizontal and vertical polarization.
4. For each suspected emissions, the antenna tower was scan (from 1 M to 4 M) and then the turntable was rotated (from 0 degree to 360 degrees) to find the maximum reading.
5. Set the test-receiver system to Peak or CISPR quasi-peak Detect Function with specified bandwidth under Maximum Hold Mode.
6. For emissions above 1GHz, use 1MHz VBW and RBW for peak reading. Then 1MHz RBW and 10Hz VBW for average reading in spectrum analyzer.
7. When the radiated emissions limits are expressed in terms of the average value of the emissions, and pulsed operation is employed, the measurement field strength shall be determined by averaging over one complete pulse train, including blanking intervals, as long as the pulse train does not exceed 0.1 seconds. As an alternative (provided the transmitter operates for longer than 0.1 seconds) or in cases where the pulse train exceeds 0.1 seconds, the measured field strength shall be determined from the average absolute voltage during a 0.1 second interval during which the field strength is at its maximum values.
8. If the emissions level of the EUT in peak mode was 3 dB lower than the average limit specified, then testing will be stopped and peak values of EUT will be reported, otherwise, the emissions which do not have 3 dB margin will be repeated one by one using the quasi-peak method for below 1GHz.
9. For testing above 1GHz, the emissions level of the EUT in peak mode was lower than average limit (that means the emissions level in peak mode also complies with the limit in average mode), then testing will be stopped and peak values of EUT will be reported, otherwise, the emissions will be measured in average mode again and reported.
10. In case the emission is lower than 30MHz, loop antenna has to be used for measurement and the recorded data should be QP measured by receiver. High - Low scan is not required in this case.

7.2 TEST SETUP

RADIATED EMISSION TEST SETUP BELOW 30MHz

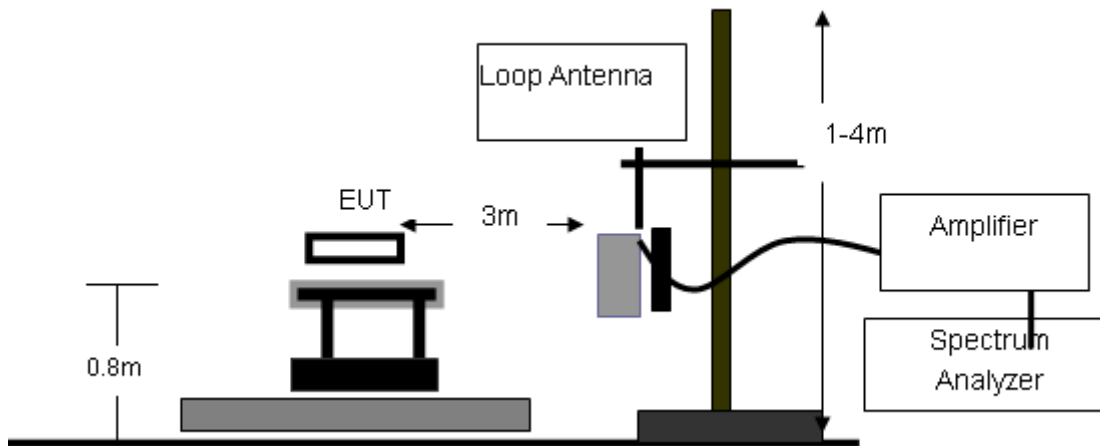

RADIATED EMISSION TEST SETUP 30MHz-1000MHz

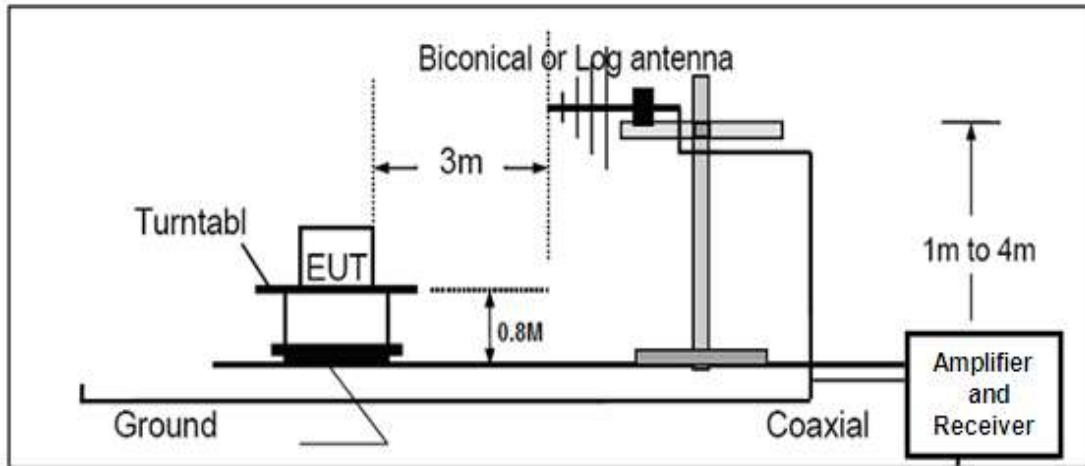

RADIATED EMISSION TEST SETUP ABOVE 1000MHz

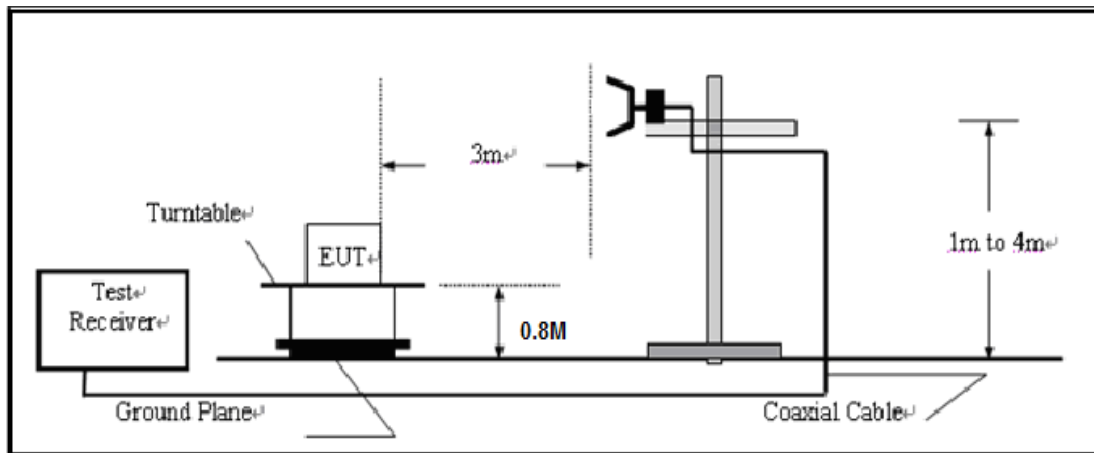

7.3 LIMITS AND MEASUREMENT RESULT

15.209 Limit in the below table has to be followed

| Frequencies (MHz) | Field Strength (micorvolts/meter) | Measurement Distance (meters) |
|------------------------------|--|--|
| 0.009~0.490 | 2400/F(KHz) | 300 |
| 0.490~1.705 | 24000/F(KHz) | 30 |
| 1.705~30.0 | 30 | 30 |
| 30~88 | 100 | 3 |
| 88~216 | 150 | 3 |
| 216~960 | 200 | 3 |
| Above 960 | 500 | 3 |

Note: All modes were tested For restricted band radiated emission,
the test records reported below are the worst result compared to other modes.

7.4 TEST RESULT

RADIATED EMISSION BELOW 30MHZ

No emission found between lowest internal used/generated frequencies to 30MHz.

RADIATED EMISSION BELOW 1GHZ

RADIATED EMISSION TEST- (30MHZ-1GHZ)-LOW CHANNEL-HORIZONTAL

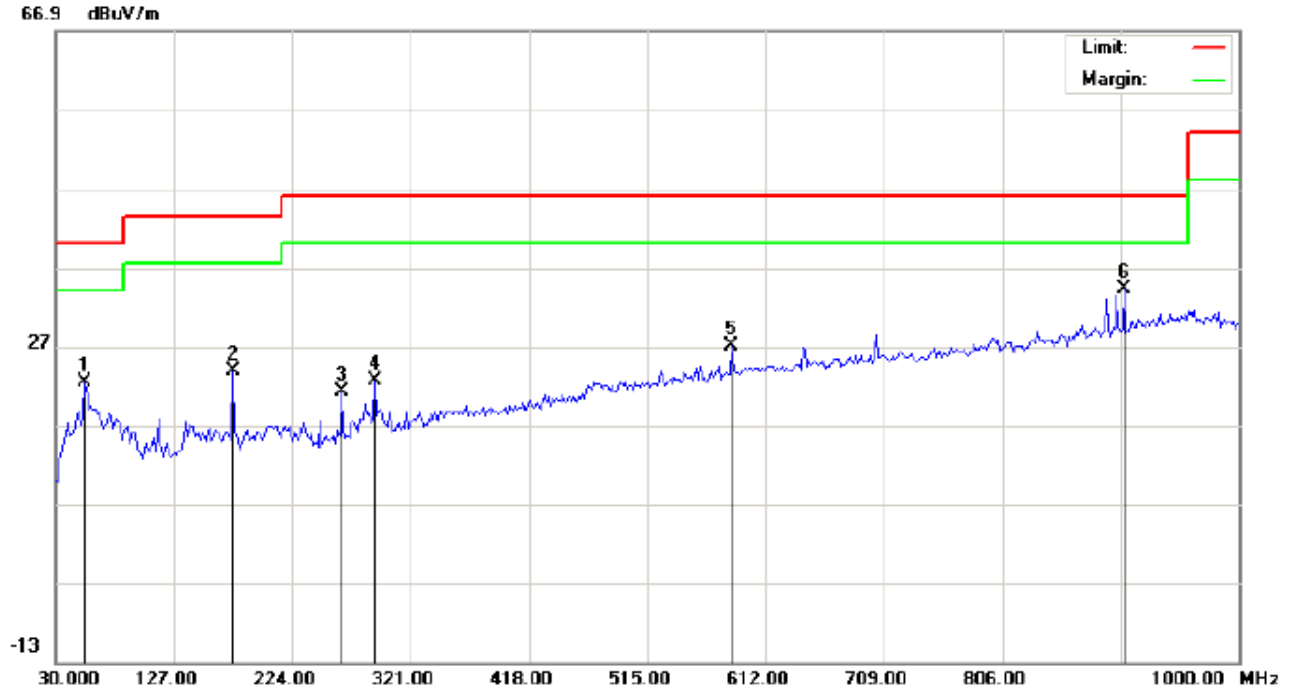

Site: site #1
Limit: FCC Class B 3M Radiation
EUT: Smart mobile phone
M/N: S1000
Mode: Low Channel TX
Note:

Polarization: *Horizontal*
Power: AC 120V/60Hz
Distance:

Temperature: 26
Humidity: 60 %

| No. | Mk | Freq. | Reading | Factor | Measurement | Limit | Over | Detector | Antenna Height | Table Degree | Comment |
|-----|----|----------|---------|--------|-------------|--------|--------|----------|----------------|--------------|---------|
| | | MHz | dBuV | dB/m | dBuV/m | dBuV/m | dB | | cm | degree | |
| 1 | | 54.2500 | 11.19 | 11.20 | 22.39 | 40.00 | -17.61 | peak | | | |
| 2 | | 175.5000 | 11.87 | 12.03 | 23.90 | 43.50 | -19.60 | peak | | | |
| 3 | | 264.4166 | 6.95 | 14.34 | 21.29 | 46.00 | -24.71 | peak | | | |
| 4 | | 291.8999 | 7.47 | 15.17 | 22.64 | 46.00 | -23.36 | peak | | | |
| 5 | | 584.5167 | 3.69 | 23.34 | 27.03 | 46.00 | -18.97 | peak | | | |
| 6 | * | 906.2332 | 5.52 | 28.78 | 34.30 | 46.00 | -11.70 | peak | | | |

RESULT: PASS

RADIATED EMISSION TEST- (30MHZ-1GHZ)-LOW CHANNEL -VERTICAL

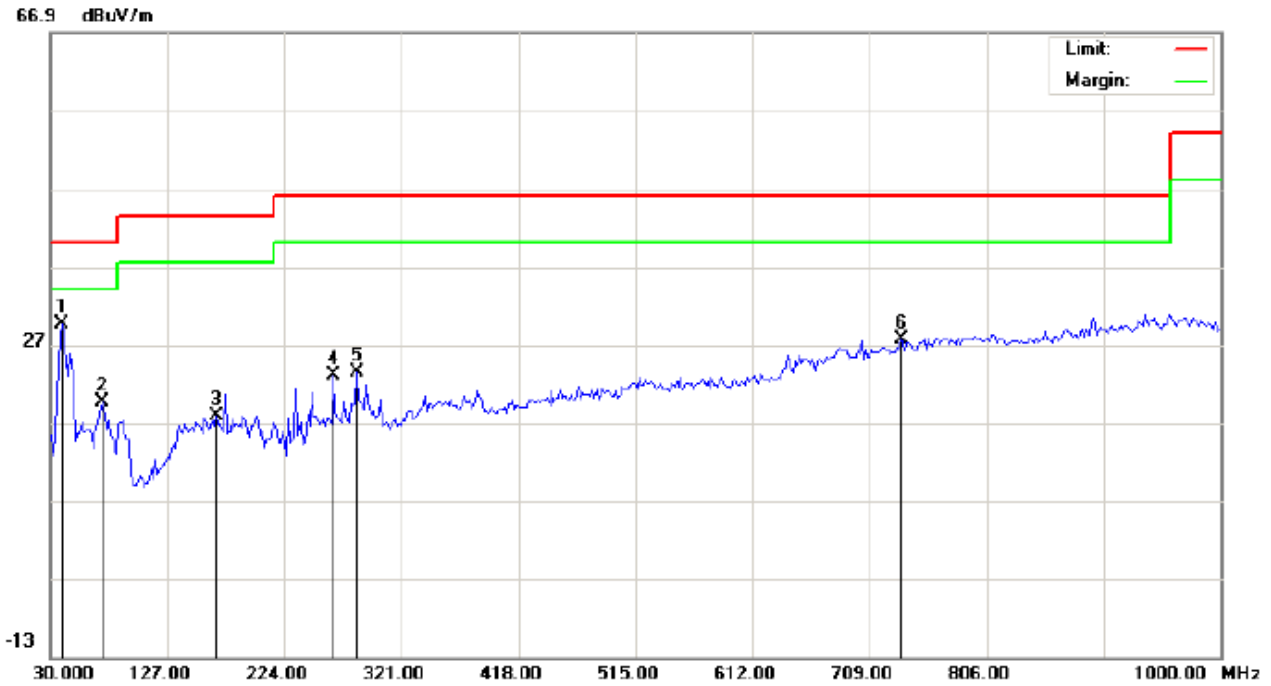

Site: site #1
Limit: FCC Class B 3M Radiation
EUT: Smart mobile phone
M/N: S1000
Mode: Low Channel TX
Note:

Polarization: *Vertical*
Power: AC 120V/60Hz
Distance:

Temperature: 26
Humidity: 60 %

| No. | Mk | Freq. | Reading | Factor | Measurement | Limit | Over | Detector | Antenna Height | Table Degree | Comment |
|-----|----|----------|---------|--------|-------------|--------|--------|----------|----------------|--------------|---------|
| | | MHz | dBuV | dB/m | dBuV/m | dBuV/m | dB | | cm | degree | |
| 1 | * | 39.7000 | 21.02 | 8.51 | 29.53 | 40.00 | -10.47 | peak | | | |
| 2 | | 73.6500 | 16.17 | 3.36 | 19.53 | 40.00 | -20.47 | peak | | | |
| 3 | | 167.4165 | 2.93 | 14.86 | 17.79 | 43.50 | -25.71 | peak | | | |
| 4 | | 264.4166 | 8.70 | 14.34 | 23.04 | 46.00 | -22.96 | peak | | | |
| 5 | | 283.8167 | 8.45 | 14.92 | 23.37 | 46.00 | -22.63 | peak | | | |
| 6 | | 734.8667 | 1.42 | 26.19 | 27.61 | 46.00 | -18.39 | peak | | | |

RESULT: PASS

RADIATED EMISSION TEST- (30MHZ-1GHZ)-MIDDLE CHANNEL-HORIZONTAL

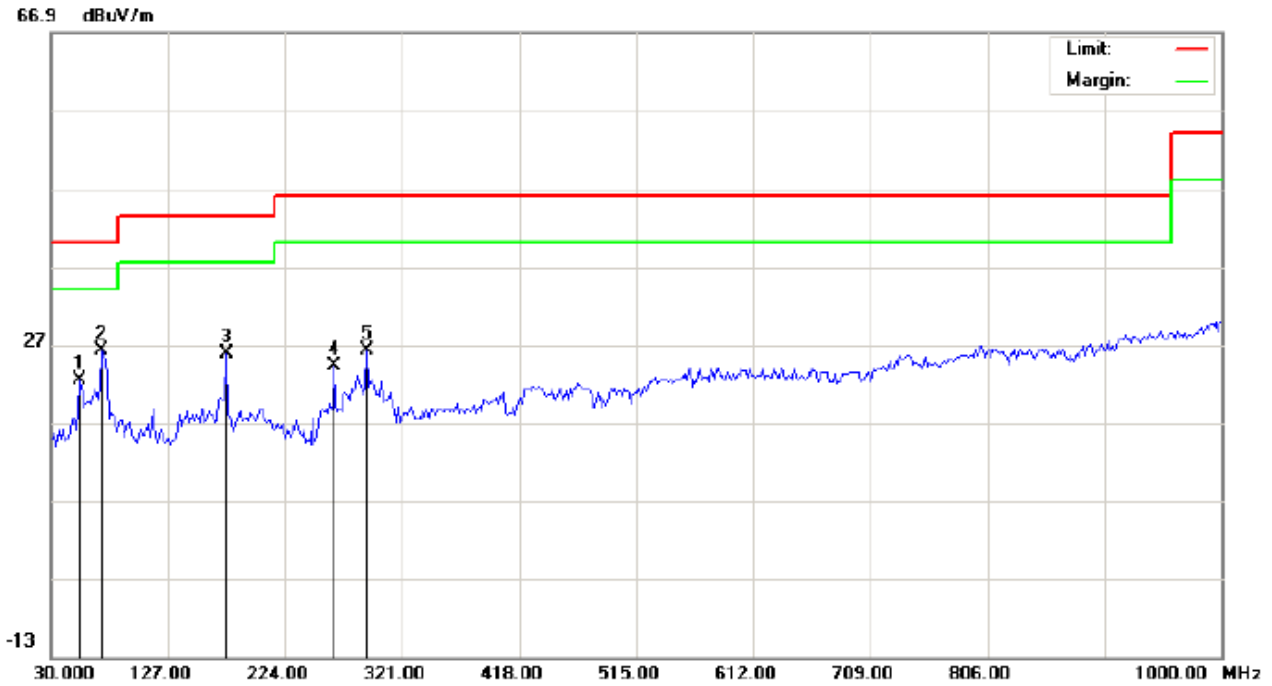

Site: site #1
Limit: FCC Class B 3M Radiation
EUT: Smart mobile phone
M/N: S1000
Mode: Middle Channel TX
Note:

Polarization: *Horizontal*
Power: AC 120V/60Hz
Distance:

Temperature: 26
Humidity: 60 %

| No. | Mk | Freq. | Reading | Factor | Measurement | Limit | Over | Detector | Antenna Height | Table Degree | Comment |
|-----|----|----------|---------|--------|-------------|--------|--------|----------|----------------|--------------|---------|
| | | MHz | dBuV | dB/m | dBuV/m | dBuV/m | dB | | cm | degree | |
| 1 | | 54.2500 | 11.19 | 11.20 | 22.39 | 40.00 | -17.61 | peak | | | |
| 2 | * | 72.0331 | 16.12 | 10.17 | 26.29 | 40.00 | -13.71 | peak | | | |
| 3 | | 175.5000 | 13.87 | 12.03 | 25.90 | 43.50 | -17.60 | peak | | | |
| 4 | | 264.4166 | 9.95 | 14.34 | 24.29 | 46.00 | -21.71 | peak | | | |
| 5 | | 291.8999 | 10.97 | 15.17 | 26.14 | 46.00 | -19.86 | peak | | | |

RESULT: PASS

RADIATED EMISSION TEST- (30MHZ-1GHZ)- MIDDLE CHANNEL -VERTICAL

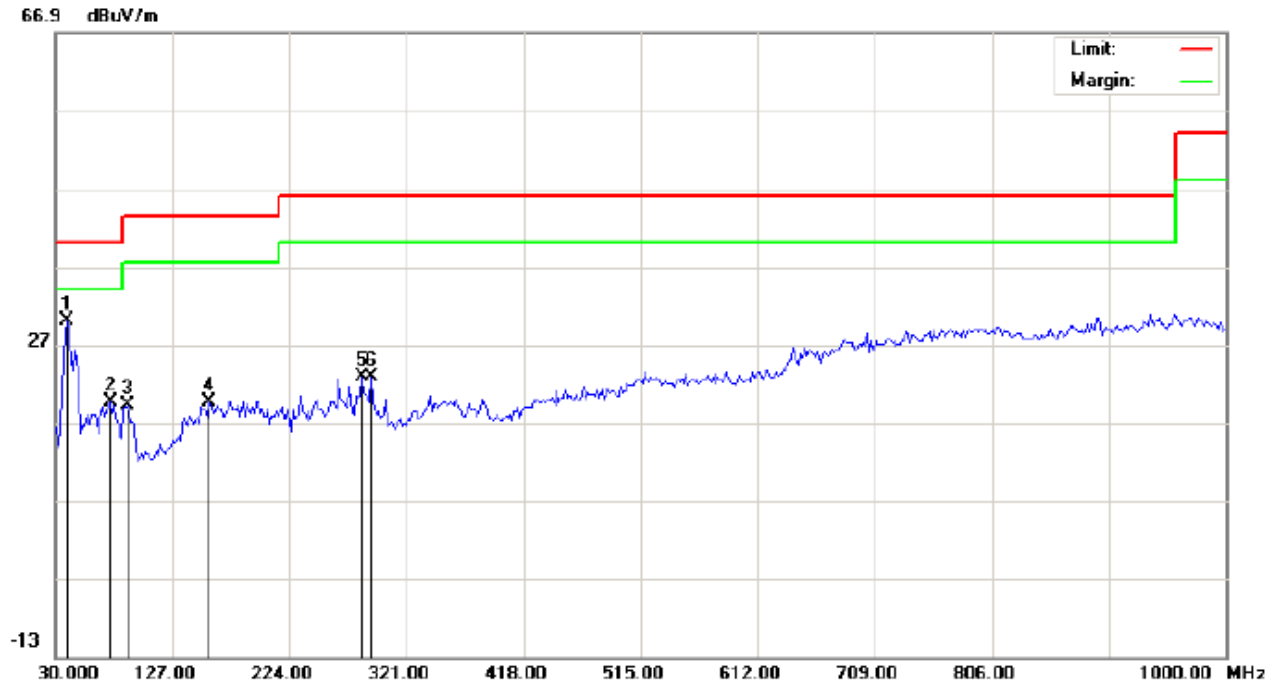

Site: site #1
Limit: FCC Class B 3M Radiation
EUT: Smart mobile phone
M/N: S1000
Mode: Middle Channel TX
Note:

Polarization: **Vertical**
Power: AC 120V/60Hz
Distance:

Temperature: 26
Humidity: 60 %

| No. | Mk | Freq. | Reading | Factor | Measurement | Limit | Over | Detector | Antenna Height | Table Degree | Comment |
|-----|----|----------|---------|--------|-------------|--------|--------|----------|----------------|--------------|---------|
| | | MHz | dBuV | dB/m | dBuV/m | dBuV/m | dB | | cm | degree | |
| 1 | * | 39.7000 | 21.52 | 8.51 | 30.03 | 40.00 | -9.97 | peak | | | |
| 2 | | 75.2667 | 16.56 | 2.96 | 19.52 | 40.00 | -20.48 | peak | | | |
| 3 | | 89.8165 | 13.82 | 5.31 | 19.13 | 43.50 | -24.37 | peak | | | |
| 4 | | 157.7167 | 4.30 | 15.32 | 19.62 | 43.50 | -23.88 | peak | | | |
| 5 | | 283.8167 | 7.95 | 14.92 | 22.87 | 46.00 | -23.13 | peak | | | |
| 6 | | 291.8999 | 7.58 | 15.17 | 22.75 | 46.00 | -23.25 | peak | | | |

RESULT: PASS

RADIATED EMISSION TEST- (30MHZ-1GHZ)-HIGH CHANNEL-HORIZONTAL

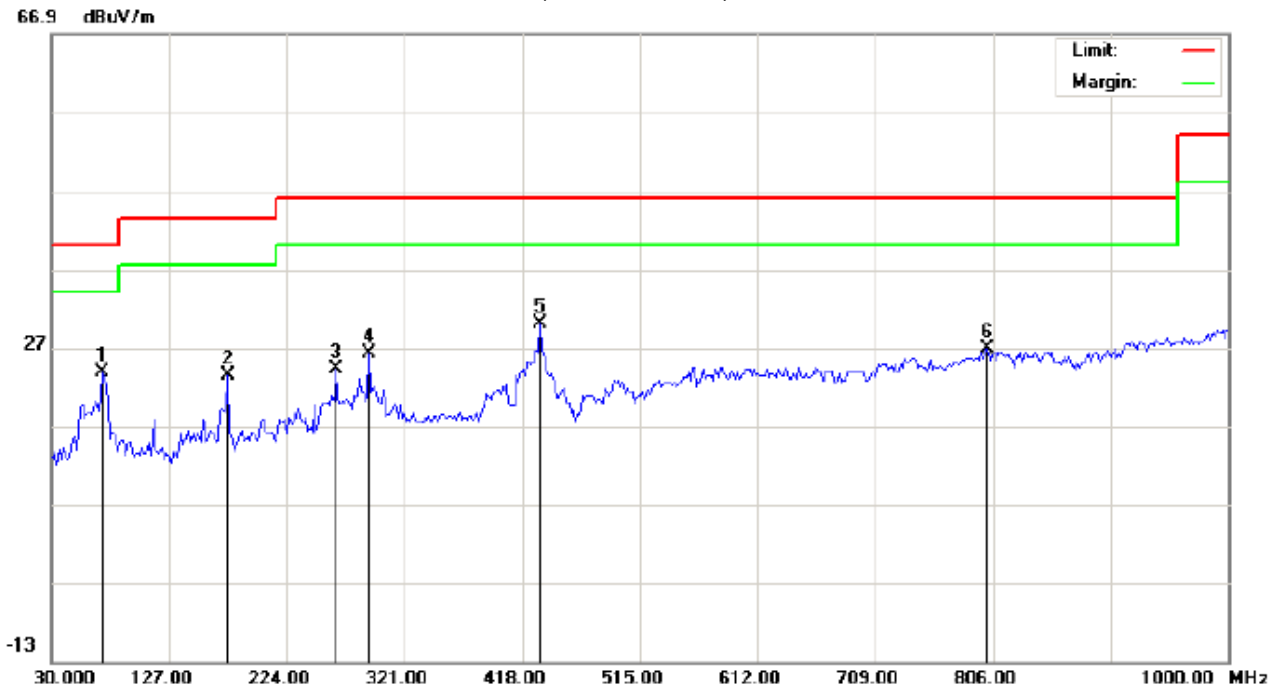

Site: site #1
Limit: FCC Class B 3M Radiation
EUT: Smart mobile phone
M/N: S1000
Mode: High Channel TX
Note:

Polarization: *Horizontal*
Power: AC 120V/60Hz
Distance:

Temperature: 26
Humidity: 60 %

| No. | Mk | Freq. | Reading | Factor | Measurement | Limit | Over | Detector | Antenna Height | Table Degree | Comment |
|-----|----|----------|---------|--------|-------------|--------|--------|----------|----------------|--------------|---------|
| | | MHz | dBuV | dB/m | dBuV/m | dBuV/m | dB | | cm | degree | |
| 1 | | 72.0331 | 13.62 | 10.17 | 23.79 | 40.00 | -16.21 | peak | | | |
| 2 | | 175.5000 | 11.37 | 12.03 | 23.40 | 43.50 | -20.10 | peak | | | |
| 3 | | 264.4166 | 9.95 | 14.34 | 24.29 | 46.00 | -21.71 | peak | | | |
| 4 | | 291.8999 | 10.97 | 15.17 | 26.14 | 46.00 | -19.86 | peak | | | |
| 5 | * | 432.5500 | 9.90 | 20.06 | 29.96 | 46.00 | -16.04 | peak | | | |
| 6 | | 801.1499 | -0.50 | 27.32 | 26.82 | 46.00 | -19.18 | peak | | | |

RESULT: PASS

RADIATED EMISSION TEST- (30MHZ-1GHZ)-HIGH CHANNEL -VERTICAL

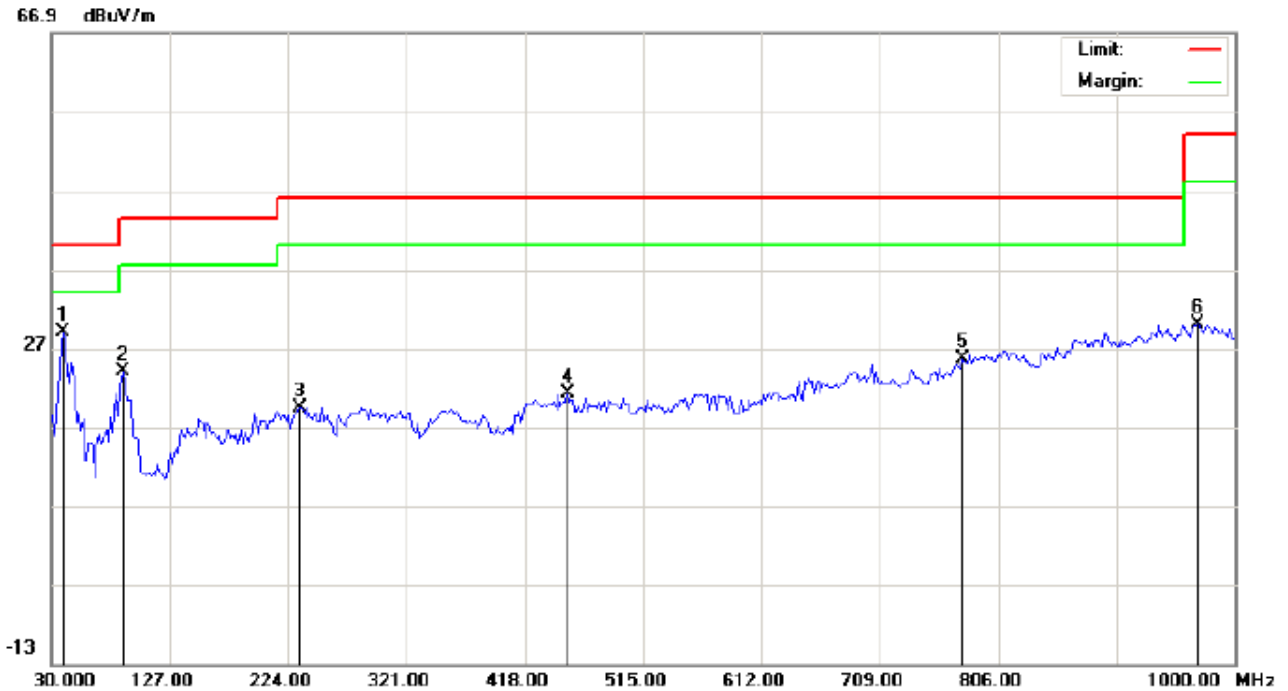

Site: site #1
Limit: FCC Class B 3M Radiation
EUT: Smart mobile phone
M/N: S1000
Mode: High Channel TX
Note:

Polarization: *Vertical*
Power: AC 120V/60Hz
Distance:

Temperature: 26
Humidity: 60 %

| No. | Mk | Freq. | Reading | Factor | Measurement | Limit | Over | Detector | Antenna | Table | Comment |
|-----|----|----------|---------|--------|-------------|--------|--------|----------|---------|--------|---------|
| | | MHz | dBuV | dB/m | dBuV/m | dBuV/m | dB | | Height | Degree | |
| | | | | | | | | | cm | degree | |
| 1 | * | 39.7000 | 20.52 | 8.51 | 29.03 | 40.00 | -10.97 | peak | | | |
| 2 | | 88.2000 | 19.25 | 4.74 | 23.99 | 43.50 | -19.51 | peak | | | |
| 3 | | 233.6999 | 7.17 | 12.30 | 19.47 | 46.00 | -26.53 | peak | | | |
| 4 | | 453.5667 | 0.50 | 20.63 | 21.13 | 46.00 | -24.87 | peak | | | |
| 5 | | 776.8999 | -1.36 | 27.00 | 25.64 | 46.00 | -20.36 | peak | | | |
| 6 | | 969.2833 | 0.15 | 29.81 | 29.96 | 54.00 | -24.04 | peak | | | |

RESULT: PASS

Note: 1. Factor=Antenna Factor + Cable loss, Margin=Measurement-Limit.

2. The "Factor" value can be calculated automatically by software of measurement system.

RADIATED EMISSION ABOVE 1GHZ
RADIATED EMISSION TEST- (ABOVE 1GHZ)-LOW CHANNEL-HORIZONTAL

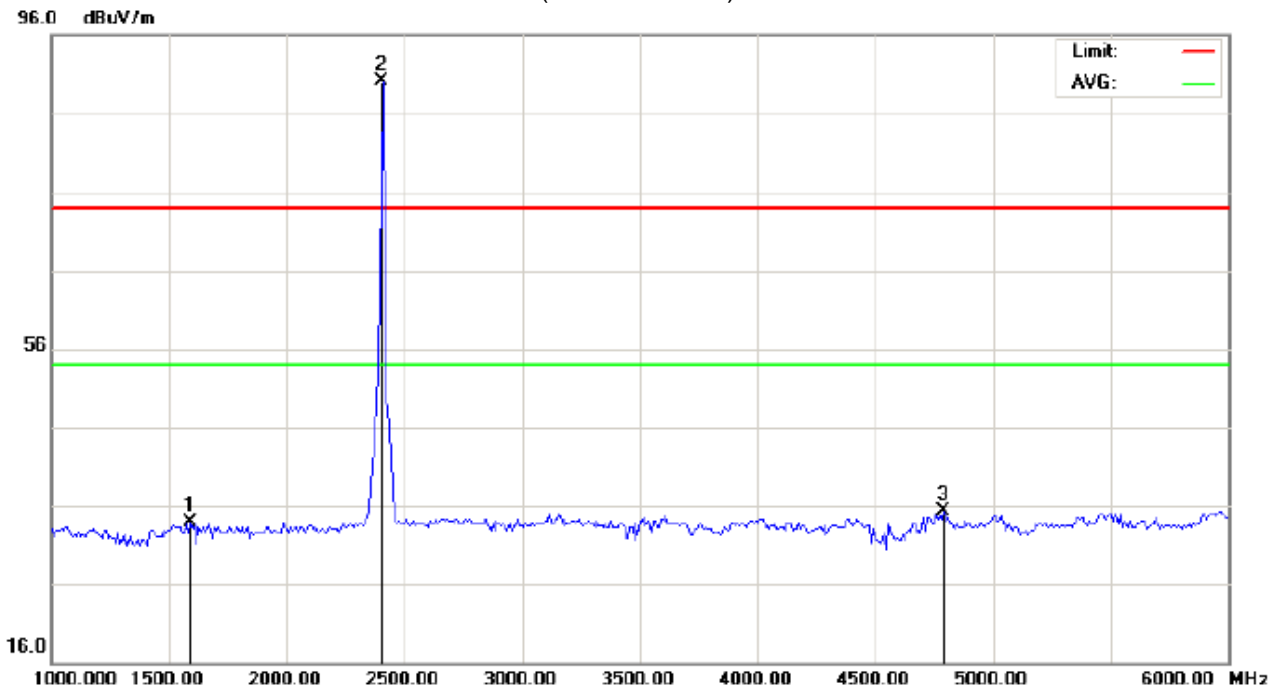

Site: site #1
Limit: FCC Class B 3M Radiation above 1GHZ(PK)
EUT: Smart mobile phone
M/N: S1000
Mode: Low Channel TX
Note:

Polarization: *Horizontal*
Power:
Distance:

Temperature: 26
Humidity: 60 %

| No. | Mk | Freq. | Reading | Factor | Measurement | Limit | Over | Detector | Antenna Height | Table Degree | Comment |
|-----|----|----------|---------|--------|-------------|--------|--------|----------|----------------|--------------|---------|
| | | MHz | dBuV | dB/m | dBuV/m | dBuV/m | dB | | cm | degree | |
| 1 | | 1591.667 | 48.38 | -14.42 | 33.96 | 74.00 | -40.04 | peak | | | |
| 2 | * | 2402.000 | 99.83 | -9.68 | 90.15 | 74.00 | 16.15 | peak | | | |
| 3 | | 4791.667 | 37.75 | -2.35 | 35.40 | 74.00 | -38.60 | peak | | | |

RESULT: PASS

RADIATED EMISSION TEST-(ABOVE 1GHZ)-HIGH CHANNEL-HORIZONTAL

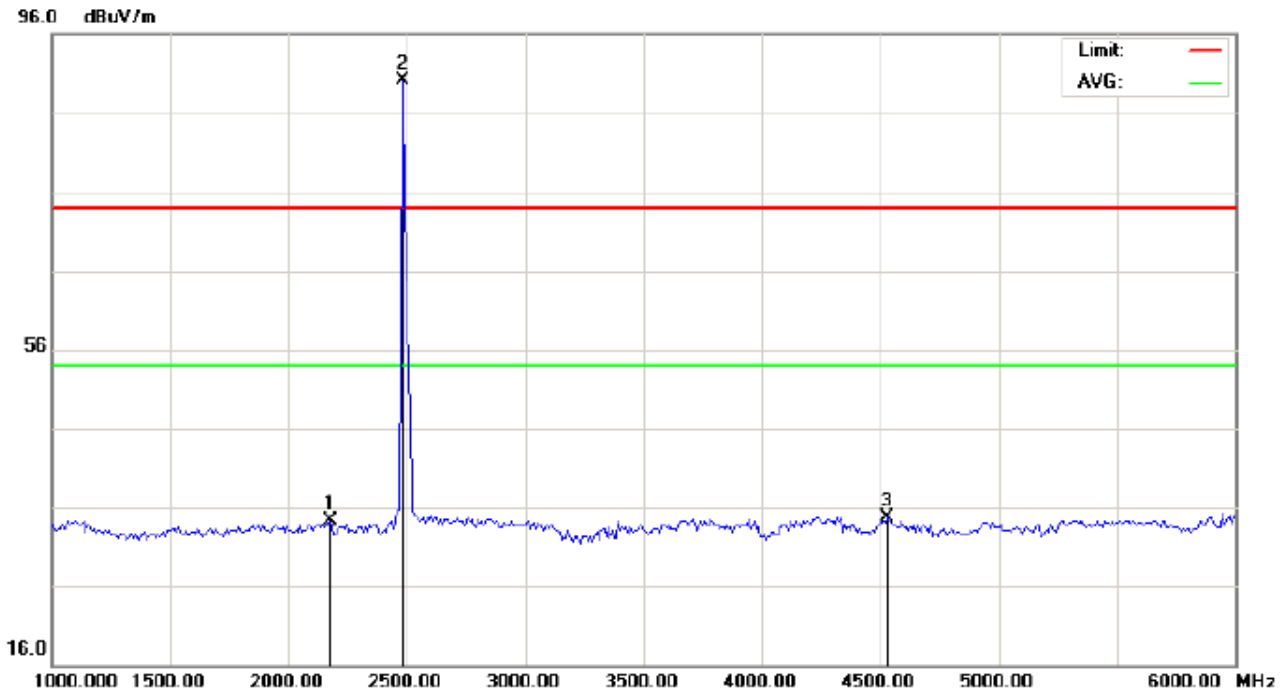

Site: site #1 Polarization: *Horizontal* Temperature: 26
 Limit: FCC Class B 3M Radiation above 1GHZ(PK) Power: Humidity: 60 %
 EUT: Smart mobile phone Distance:
 M/N: S1000
 Mode: High Channel TX
 Note:

| No. | Mk | Freq. | Reading | Factor | Measurement | Limit | Over | Detector | Antenna Height | Table Degree | Comment |
|-----|----|----------|---------|--------|-------------|--------|--------|----------|----------------|--------------|---------|
| | | MHz | dBuV | dB/m | dBuV/m | dBuV/m | dB | | cm | degree | |
| 1 | | 2175.000 | 44.26 | -9.93 | 34.33 | 74.00 | -39.67 | peak | | | |
| 2 | * | 2480.000 | 99.67 | -9.59 | 90.08 | 74.00 | 16.08 | peak | | | |
| 3 | | 4533.333 | 37.82 | -3.02 | 34.80 | 74.00 | -39.20 | peak | | | |

RESULT: PASS

8. BAND EDGE EMISSION

8.1. MEASUREMENT PROCEDURE

1. Set the EUT Work on the top, the bottom operation frequency individually.
2. Set SPA Start or Stop Frequency = Operation Frequency, $RBW \geq 1\% \text{span}$, $VBW \geq RBW$
3. The band edges was measured and recorded.

8.2. TEST SET-UP

Radiated same as 6.2

TEST PLOT OF BAND EDGE FOR HIGH CHANNEL -Vertical

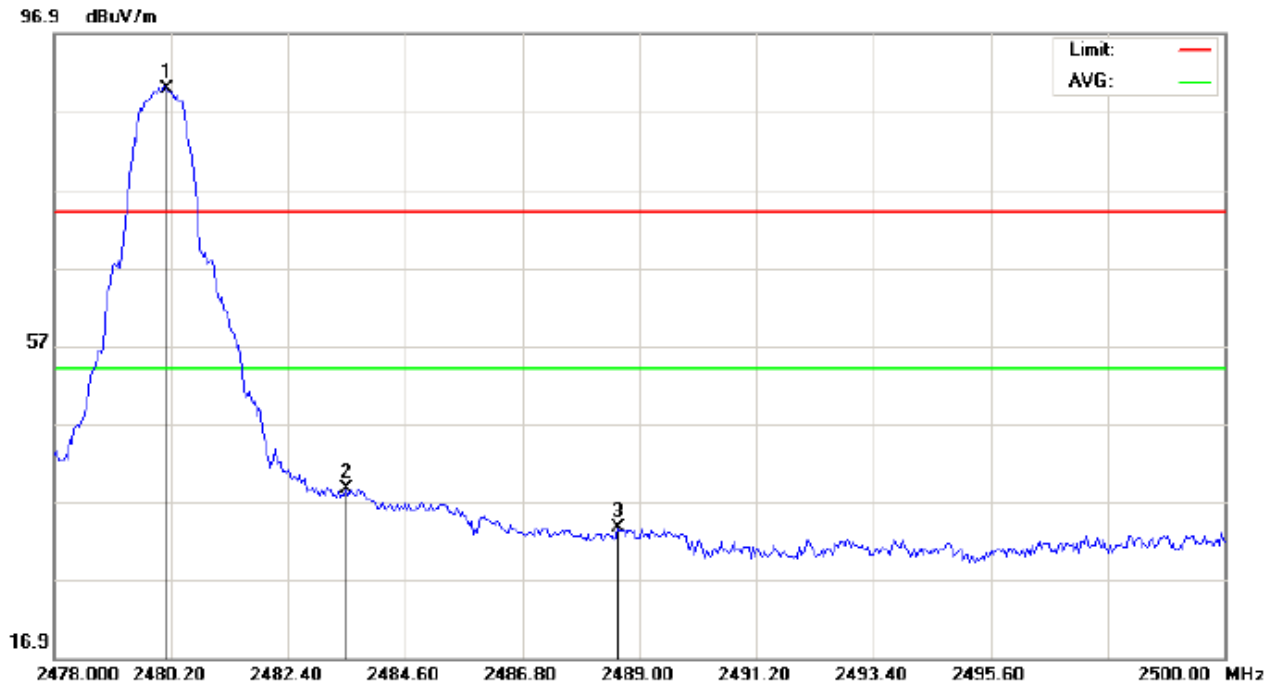

Site: site #1 Polarization: *Vertical* Temperature: 26
Limit: FCC Class B 3M Radiation above 1GHZ(PK) Power: Humidity: 60 %
EUT: Smart mobile phone Distance:
M/N: S1000
Mode: High Channel TX
Note:

| No. | Mk | Freq. | Reading | Factor | Measurement | Limit | Over | Detector | Antenna Height | Table Degree | Comment |
|-----|----|----------|---------|--------|-------------|--------|--------|----------|----------------|--------------|---------|
| | | MHz | dBuV | dB/m | dBuV/m | dBuV/m | dB | | cm | degree | |
| 1 | * | 2480.121 | 99.43 | -9.59 | 89.84 | 74.00 | 15.84 | peak | | | |
| 2 | | 2483.500 | 48.12 | -9.59 | 38.53 | 74.00 | -35.47 | peak | | | |
| 3 | | 2488.597 | 43.10 | -9.58 | 33.52 | 74.00 | -40.48 | peak | | | |

RESULT: PASS

Note: The other modes radiation emission have enough 20dB margin.

Factor=Antenna Factor + Cable loss - Amplifier gain, Over=Measure-Limit.

The "Factor" value can be calculated automatically by software of measurement system.

9. 6DB BANDWIDTH

9.1. TEST EQUIPMENT LIST AND DETAILS

| Equipment | Manufacturer | Model | S/N | Cal. Date | Cal. Due |
|---------------------------------|--------------|--------|------------|------------|------------|
| PSA SERIES SPECTRUM ANALYZER | AGILENT | E4440A | US41421290 | 07/17/2013 | 07/16/2014 |
| RECEIVER ANTENNA | ETS | 2175 | 57337 | 07/17/2013 | 07/16/2014 |

9.2. TEST PROCEDURE

1. The EUT was placed on a table which is 0.8m above ground plane.
2. Connect EUT RF output port to the Spectrum Analyzer through an RF attenuator
3. Set the EUT Work on the top, the middle and the bottom operation frequency individually.
3. Set SPA Centre Frequency = Operation Frequency, RBW= 100 KHz, VBW \geq RBW.
4. Set SPA Trace 1 Max hold, then View.

9.3. SUMMARY OF TEST RESULTS/PLOTS

| Channel | 6dB Bandwidth (KHz) | Minimum Limit (KHz) | Pass/Fail |
|---------|---------------------|---------------------|-----------|
| Low | 680.938 | 500KHz | Pass |
| Middle | 680.100 | | Pass |
| High | 706.769 | | Pass |

TEST PLOT OF BANDWIDTH FOR LOW CHANNEL

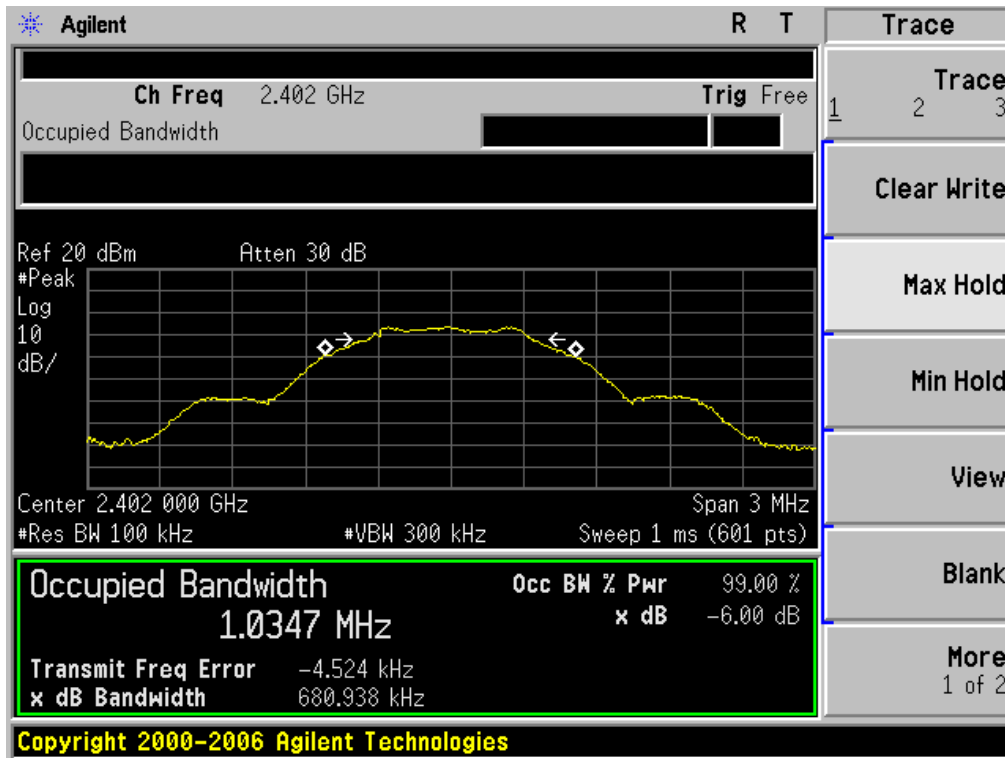

TEST PLOT OF BANDWIDTH FOR MIDDLE CHANNEL

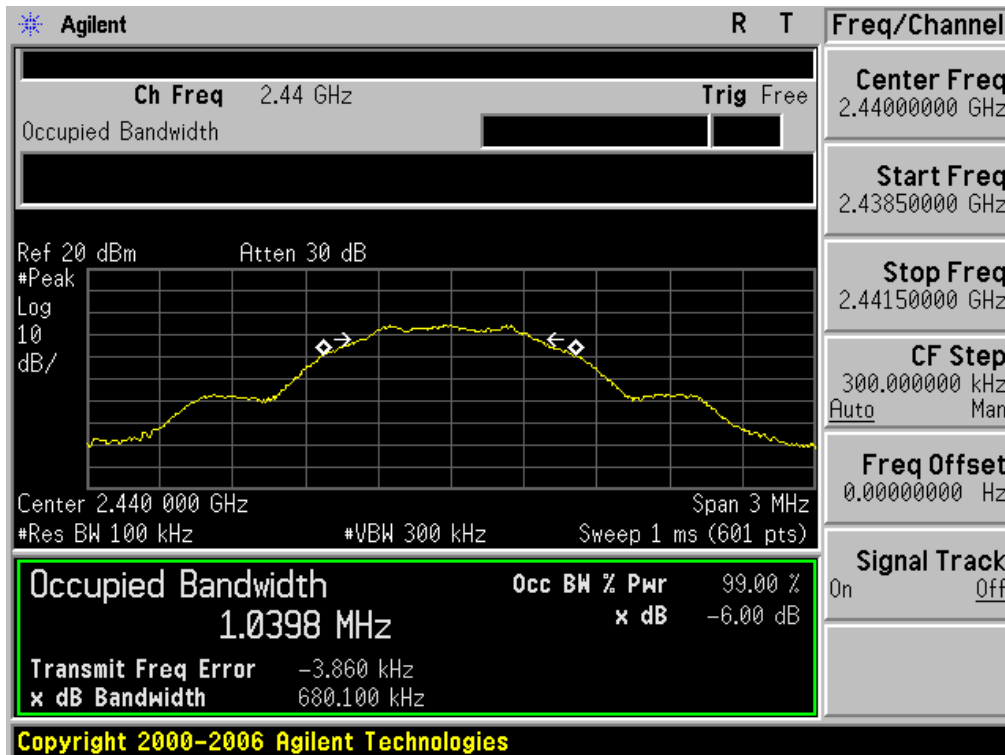

TEST PLOT OF BANDWIDTH FOR HIGH CHANNEL

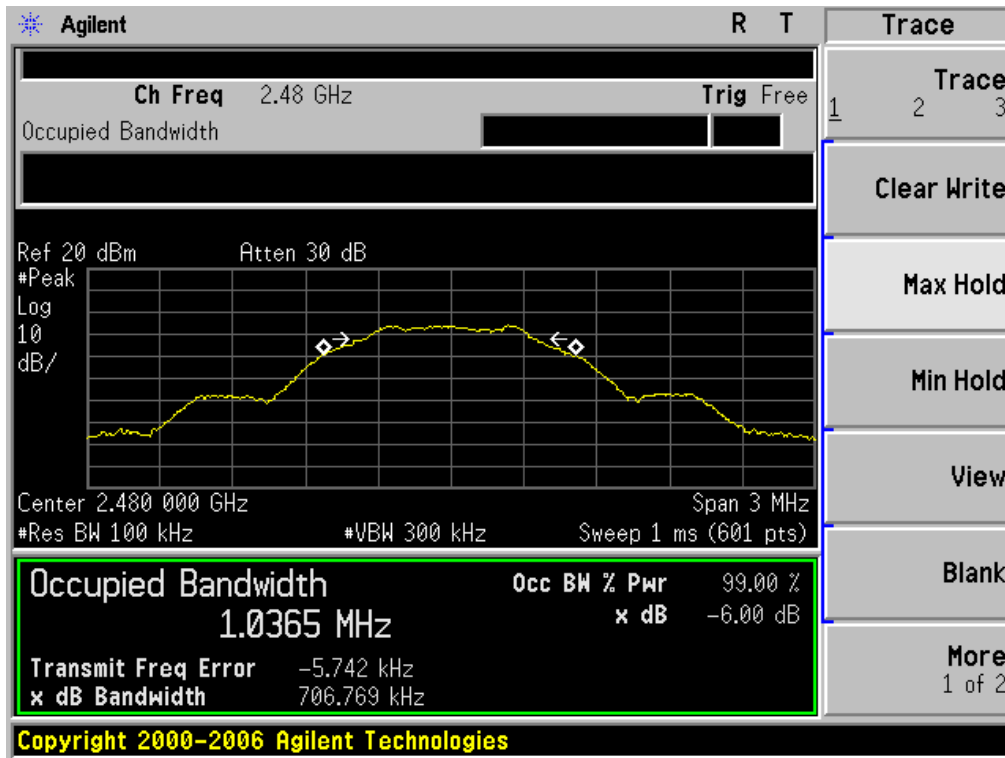

10. CONDUCTED OUTPUT POWER

10.1. MEASUREMENT PROCEDURE

1. The EUT was placed on a turn table which is 0.8m above ground plane.
 2. Connect EUT RF output port to the Spectrum Analyzer through an RF attenuator
 3. Set the EUT Work on the top, middle and the bottom operation frequency individually.
 4. Use the following spectrum analyzer settings:
Set the RBW = 1 MHz
Set the VBW \geq 3 RBW
Set the span \geq 1.5 x DTS bandwidth
Detector = peak
Sweep time = auto couple
Trace mode = max hold
 5. Allow the trace to stabilize. Use the instrument's band/channel power measurement function with the band limits set equal to the DTS bandwidth edges.
 6. Record the result form the Spectrum Analyzer.
- Note:** The EUT was tested according to KDB 558074 for compliance to FCC 47CFR 15.247 requirements.

10.2. TEST SET-UP (BLOCK DIAGRAM OF CONFIGURATION)

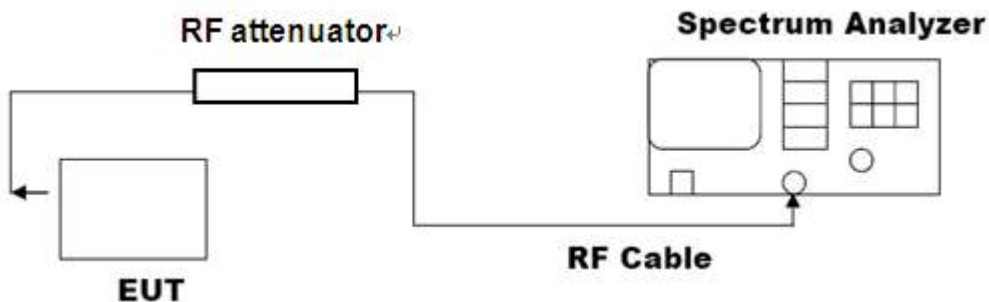

10.3. LIMITS AND MEASUREMENT RESULT

| Channel | Peak Power (dBm) | Applicable Limits (dBm) | Pass/Fail |
|----------------|------------------|-------------------------|-----------|
| Low Channel | -5.68 | 20 | Pass |
| Middle Channel | -4.99 | 20 | Pass |
| High Channel | -5.11 | 20 | Pass |

The Low Channel Result

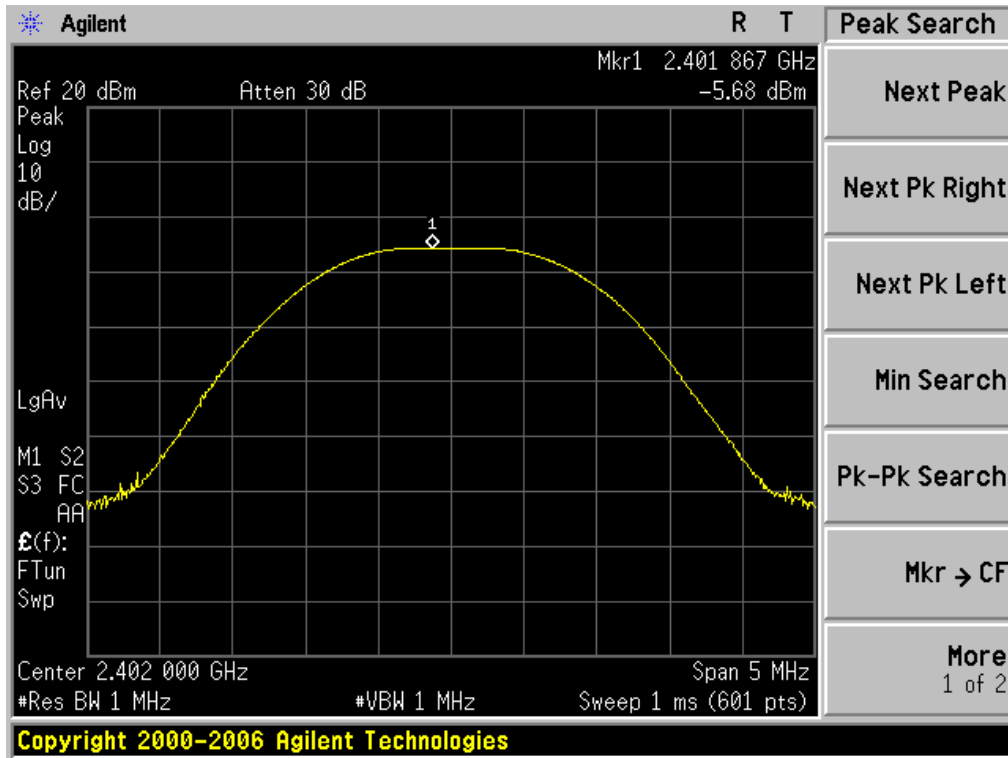

The Middle Channel Result

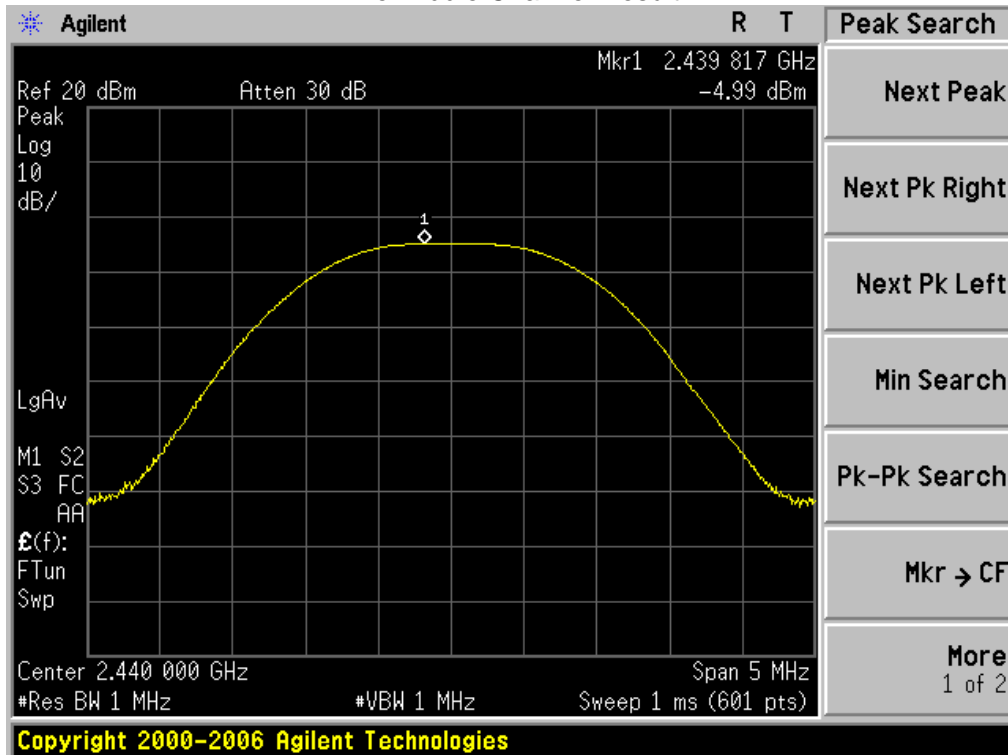

The High Channel Result

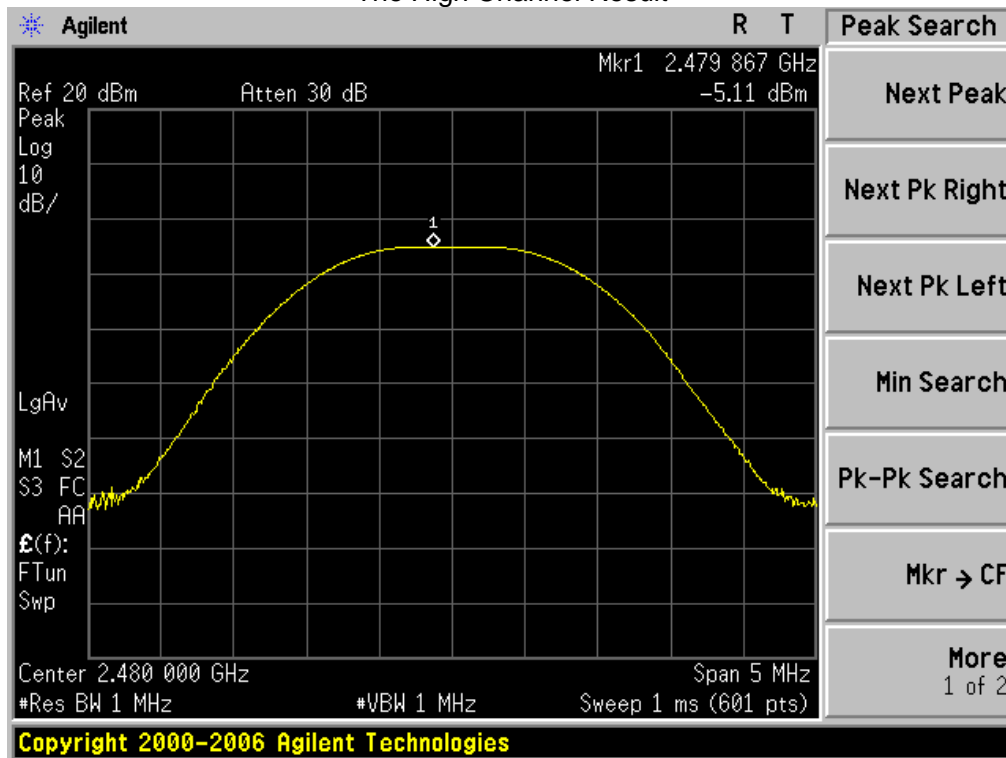

11. MAXIMUM CONDUCTED OUTPUT POWER SPECTRAL DENSITY

11.1 MEASUREMENT PROCEDURE

- (1). The EUT was placed on a turn table which is 0.8m above ground plane.
- (2). Connect EUT RF output port to the Spectrum Analyzer through an RF attenuator
- (3). Set the EUT Work on the top, the middle and the bottom operation frequency individually.
- (4). Set SPA Trace 1 Max hold, then View.

Note: The EUT was tested according to KDB 558074 for compliance to FCC 47CFR 15.247 requirements.

11.2 TEST SET-UP (BLOCK DIAGRAM OF CONFIGURATION)

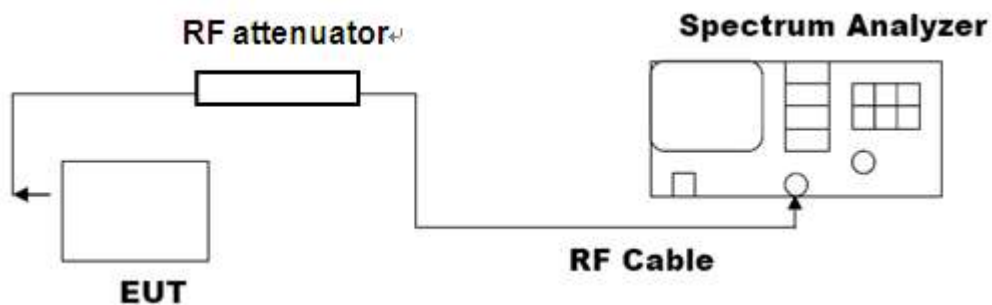

11.3 MEASUREMENT EQUIPMENT USED

| Equipment | Manufacturer | Model | S/N | Cal. Date | Cal. Due |
|------------------------------|--------------|--------|------------|------------|------------|
| PSA SERIES SPECTRUM ANALYZER | AGILENT | E4440A | US41421290 | 07/17/2013 | 07/16/2014 |
| RECEIVER ANTENNA | ETS | 2175 | 57337 | 07/17/2013 | 07/16/2014 |

11.4 LIMITS AND MEASUREMENT RESULT

| Channel No. | PSD (dBm) | Limit (dBm) | Result |
|----------------|-----------|-------------|--------|
| Low Channel | -20.93 | 8 | Pass |
| Middle Channel | -20.24 | 8 | Pass |
| High Channel | -20.41 | 8 | Pass |

TEST PLOT OF SPECTRAL DENSITY FOR LOW CHANNEL

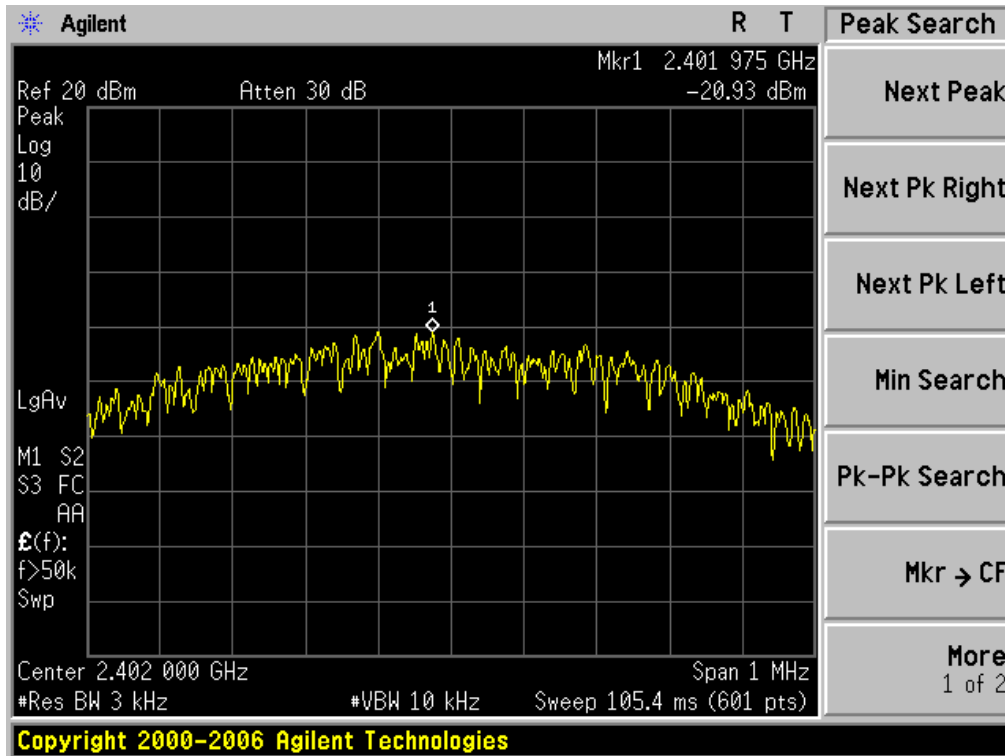

TEST PLOT OF SPECTRAL DENSITY FOR MIDDLE CHANNEL

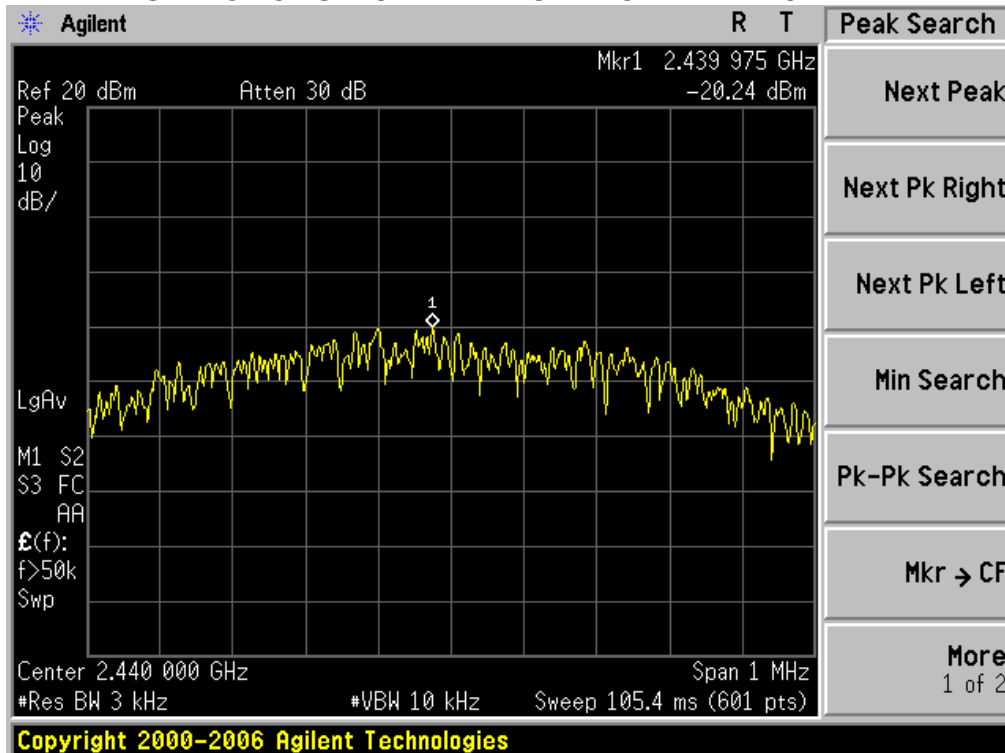

TEST PLOT OF SPECTRAL DENSITY FOR HIGH CHANNEL

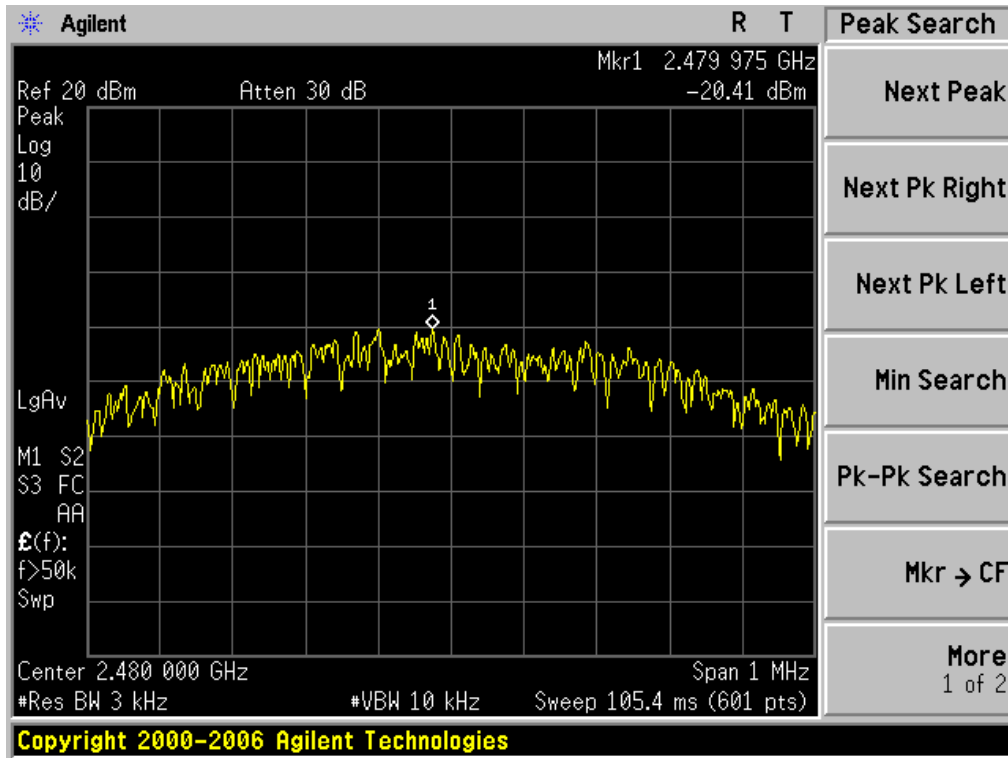

12. FCC LINE CONDUCTED EMISSION TEST

12.1 LIMITS

| Frequency | Maximum RF Line Voltage | |
|---------------|-------------------------|----------------|
| | Q.P.(dBuV) | Average(dBuV) |
| 150kHz~500kHz | 66-56 | 56-46 |
| 500kHz~5MHz | 56 | 46 |
| 5MHz~30MHz | 60 | 50 |

- **Note:** 1. The lower limit shall apply at the transition frequency.
2. The limit decreases linearly with the logarithm of the frequency in the range 0.15 MHz to 0.50 MHz

12.2 TEST SETUP

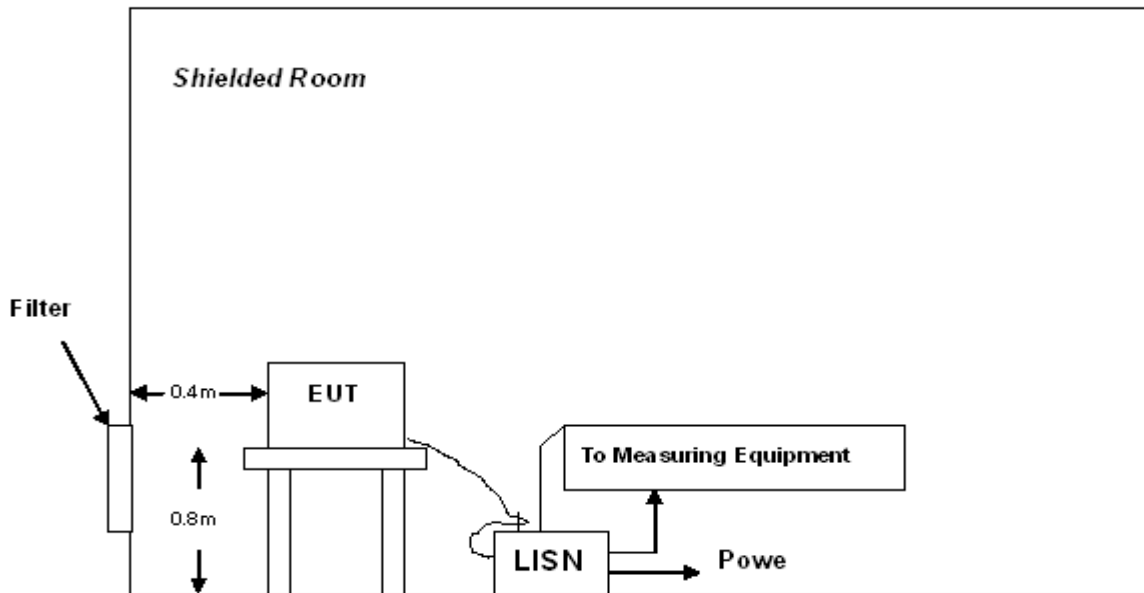

A: Powered through filter

12.3 PRELIMINARY PROCEDURE

- 1) The equipment was set up as per the test configuration to simulate typical actual usage per the user's manual. When the EUT is a tabletop system, a wooden table with a height of 0.8 meters is used and is placed on the ground plane as per ANSI C63.4 (see Test Facility for the dimensions of the ground plane used). When the EUT is a floor-standing equipment, it is placed on the ground plane which has a 3-12 mm non-conductive covering to insulate the EUT from the ground plane.
- 2) Support equipment, if needed, was placed as per ANSI C63.4.
- 3) All I/O cables were positioned to simulate typical actual usage as per ANSI C63.4.
- 4) All support equipments received AC120V/60Hz power from a LISN, if any.
- 5) The EUT received power by adapter which received power by a LISN.
- 6) The test program was started. Emissions were measured on each current carrying line of the EUT using a spectrum Analyzer / Receiver connected to the LISN powering the EUT. The LISN has two monitoring points: Line 1 (Hot Side) and Line 2 (Neutral Side). Two scans were taken: one with Line 1 connected to Analyzer / Receiver and Line 2 connected to a 50 ohm load; the second scan had Line 1 connected to a 50 ohm load and Line 2 connected to the Analyzer / Receiver.
- 7) Analyzer / Receiver scanned from 150 kHz to 30MHz for emissions in each of the test modes.
- 8) During the above scans, the emissions were maximized by cable manipulation.
- 9) The following test mode(s) were scanned during the preliminary test.
Then, the EUT configuration and cable configuration of the above highest emission level were recorded for reference of final testing.

12.4 FINAL TEST PROCEDURE

- 10) EUT and support equipment was set up on the test bench as per step 2 of the preliminary test.
- 11) 2) A scan was taken on both power lines, Line 1 and Line 2, recording at least the six highest emissions. Emission frequency and amplitude were recorded into a computer in which correction factors were used to calculate the emission level and compare reading to the applicable limit. If EUT emission level was less -2dB to the A.V. limit in Peak mode, then the emission signal was re-checked using Q.P and Average detector.
- 12) 3) The test data of the worst case condition(s) was reported on the Summary Data page.

12.5 TEST RESULT OF POWER LINE

Line Conducted Emission Test Line 1-L

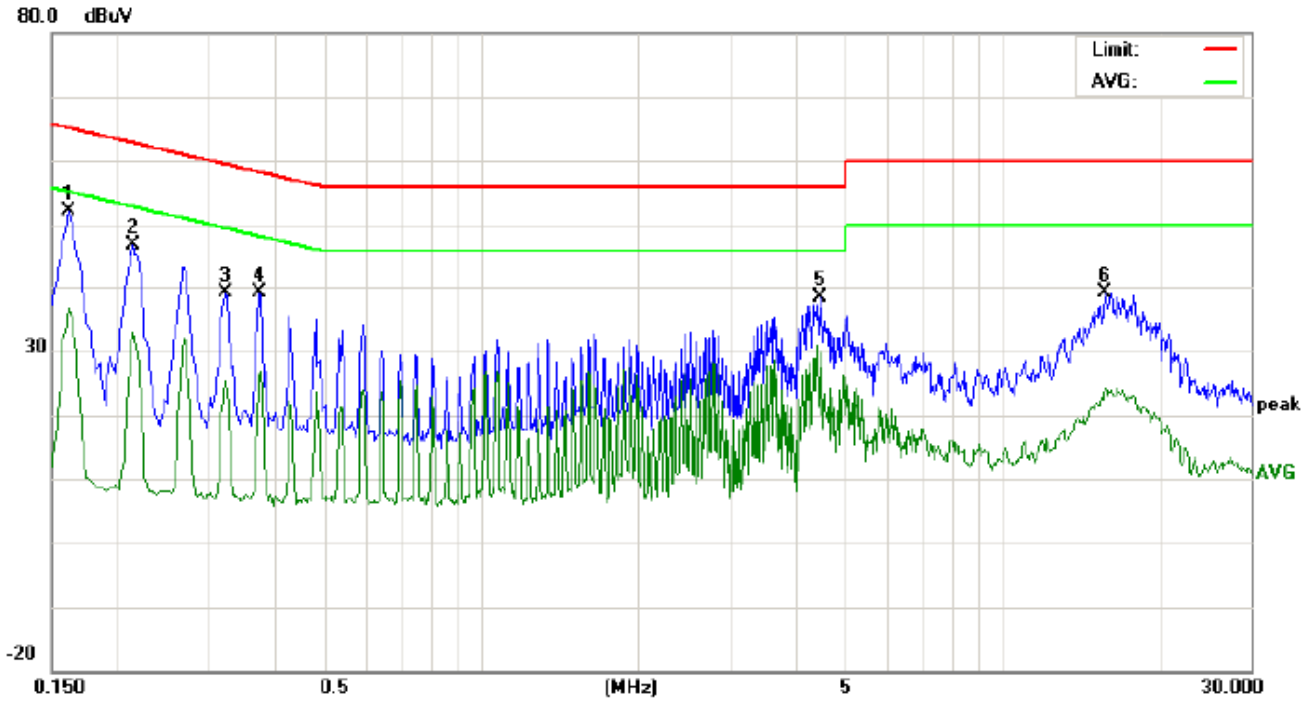

Site: Conduction Phase: **L1** Temperature: 26
 Limit: FCC Class B Conduction(QP) Power: AC 120V/60Hz Humidity: 60 %
 EUT: Smart mobile phone
 M/N: S1000
 Mode: Normal Operating(BT)
 Note:

| No. | Freq. (MHz) | Reading_Level (dBuV) | | | Correct Factor (dB) | Measurement (dBuV) | | | Limit (dBuV) | | Margin (dB) | | P/F | Comment |
|-----|-------------|----------------------|----|-------|---------------------|--------------------|----|-------|--------------|-------|-------------|--------|-----|---------|
| | | Peak | QP | AVG | | Peak | QP | AVG | QP | AVG | QP | AVG | | |
| 1 | 0.1620 | 41.98 | | 26.53 | 10.17 | 52.15 | | 36.70 | 65.36 | 55.36 | -13.21 | -18.66 | P | |
| 2 | 0.2139 | 36.66 | | 22.60 | 10.23 | 46.89 | | 32.83 | 63.05 | 53.05 | -16.16 | -20.22 | P | |
| 3 | 0.3234 | 28.89 | | 14.55 | 10.30 | 39.19 | | 24.85 | 59.62 | 49.62 | -20.43 | -24.77 | P | |
| 4 | 0.3750 | 28.77 | | 15.71 | 10.32 | 39.09 | | 26.03 | 58.39 | 48.39 | -19.30 | -22.36 | P | |
| 5 | 4.4618 | 28.26 | | 19.64 | 10.23 | 38.49 | | 29.87 | 56.00 | 46.00 | -17.51 | -16.13 | P | |
| 6 | 15.7979 | 29.12 | | 13.94 | 10.11 | 39.23 | | 24.05 | 60.00 | 50.00 | -20.77 | -25.95 | P | |

Line Conducted Emission Test Line 1-N

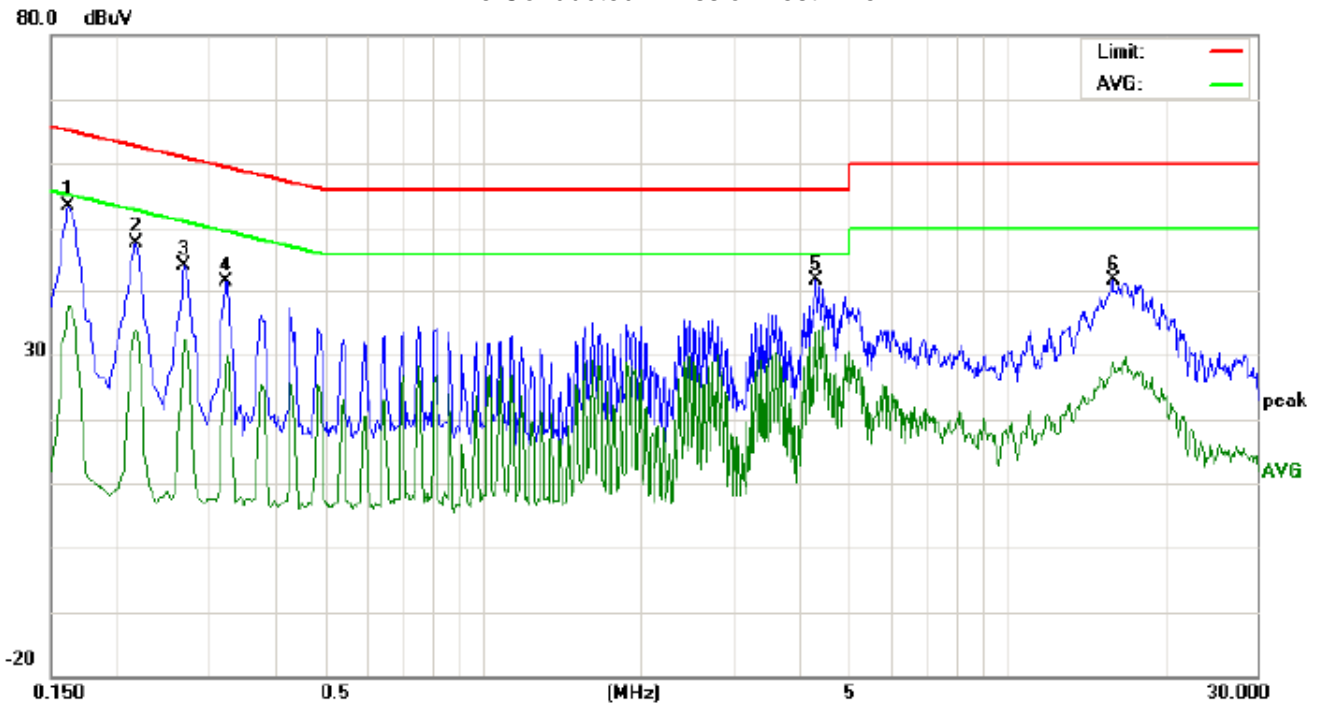

Site: Conduction Phase: **N** Temperature: 26
Limit: FCC Class B Conduction(QP) Power: AC 120V/60Hz Humidity: 60 %
EUT: Smart mobile phone
M/N: S1000
Mode: Normal Operating(BT)
Note:

| No. | Freq. (MHz) | Reading_Level (dBuV) | | | Correct Factor (dB) | Measurement (dBuV) | | | Limit (dBuV) | | Margin (dB) | | P/F | Comment |
|-----|-------------|----------------------|----|-------|---------------------|--------------------|----|-------|--------------|-------|-------------|--------|-----|---------|
| | | Peak | QP | AVG | | Peak | QP | AVG | QP | AVG | QP | AVG | | |
| 1 | 0.1620 | 43.19 | | 27.54 | 10.17 | 53.36 | | 37.71 | 65.36 | 55.36 | -12.00 | -17.65 | P | |
| 2 | 0.2179 | 37.51 | | 23.74 | 10.23 | 47.74 | | 33.97 | 62.89 | 52.89 | -15.15 | -18.92 | P | |
| 3 | 0.2700 | 33.93 | | 22.06 | 10.28 | 44.21 | | 32.34 | 61.12 | 51.12 | -16.91 | -18.78 | P | |
| 4 | 0.3234 | 31.17 | | 17.43 | 10.30 | 41.47 | | 27.73 | 59.62 | 49.62 | -18.15 | -21.89 | P | |
| 5 | 4.3258 | 31.26 | | 23.17 | 10.29 | 41.55 | | 33.46 | 56.00 | 46.00 | -14.45 | -12.54 | P | |
| 6 | 15.9579 | 31.53 | | 18.52 | 10.11 | 41.64 | | 28.63 | 60.00 | 50.00 | -18.36 | -21.37 | P | |

APPENDIX A: PHOTOGRAPHS OF TEST SETUP

FCC LINE CONDUCTED EMISSION TEST SETUP



FCC RADIATED EMISSION TEST SETUP

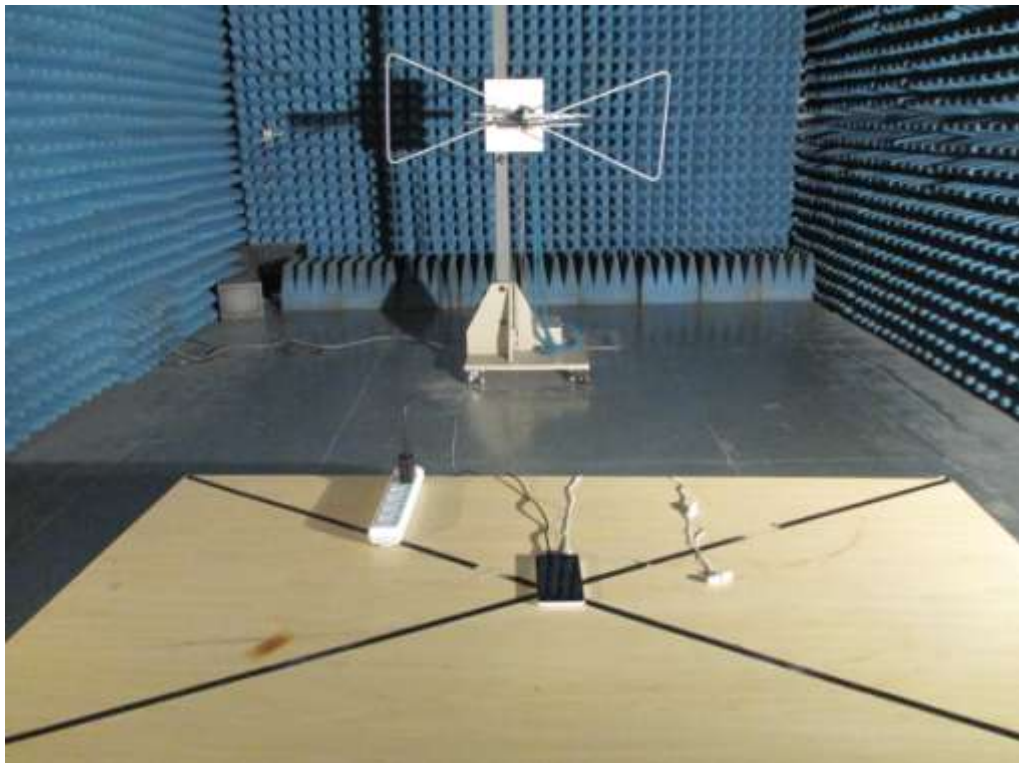

APPENDIX B: PHOTOGRAPHS OF EUT TOTAL VIEW OF EUT



TOP VIEW OF EUT



BOTTOM VIEW OF EUT



FRONT VIEW OF EUT



BACK VIEW OF EUT



LEFT VIEW OF EUT

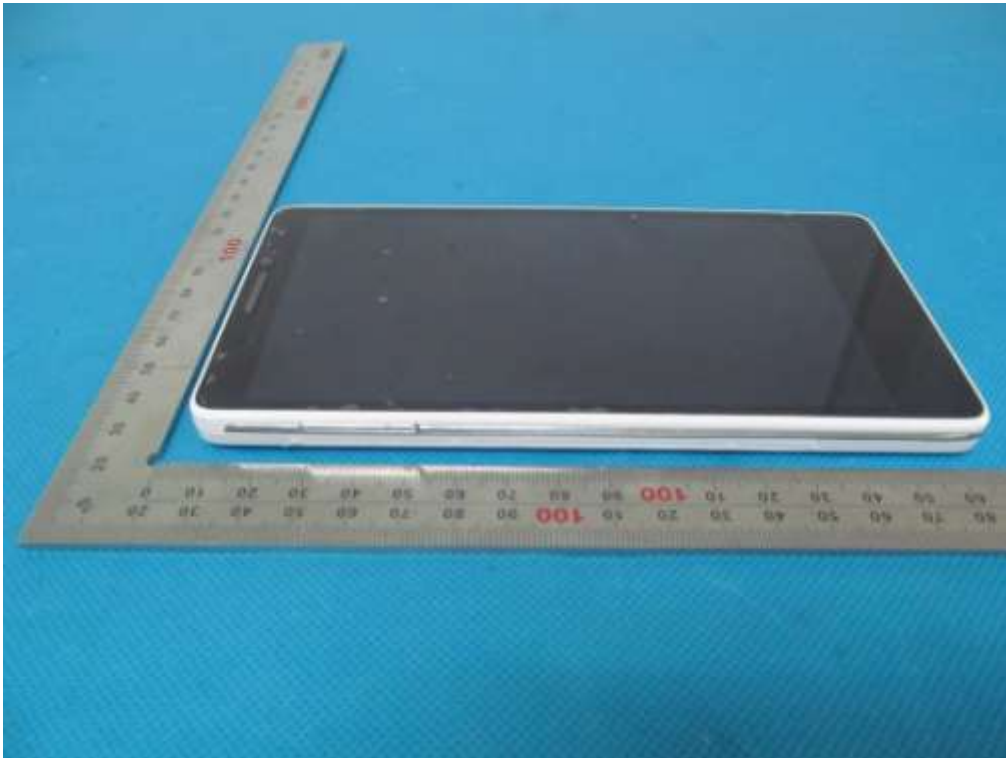

RIGHT VIEW OF EUT

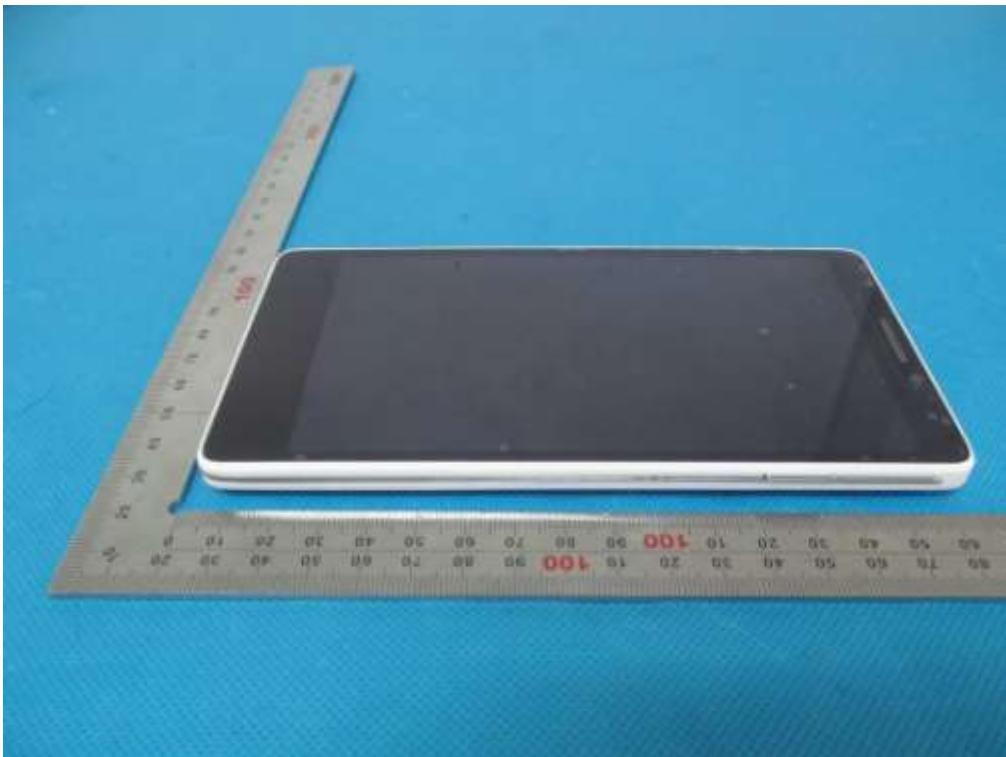

OPEN VIEW OF EUT-1

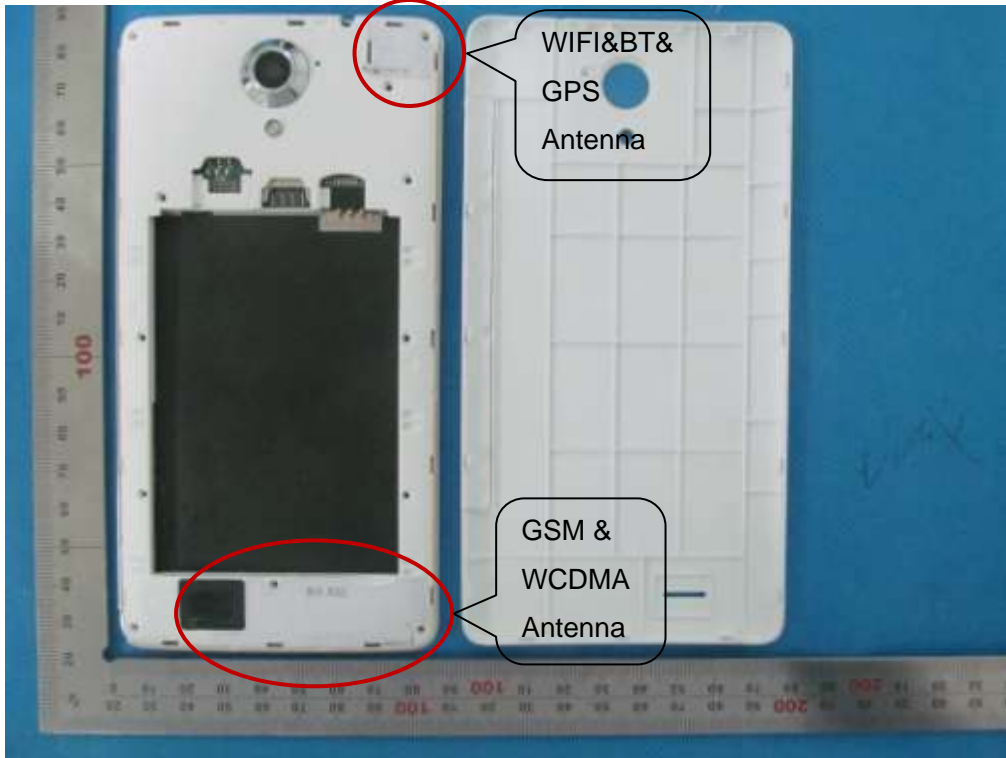

OPEN VIEW OF EUT-2



OPEN VIEW OF EUT-3



INTERNAL VIEW OF EUT-1

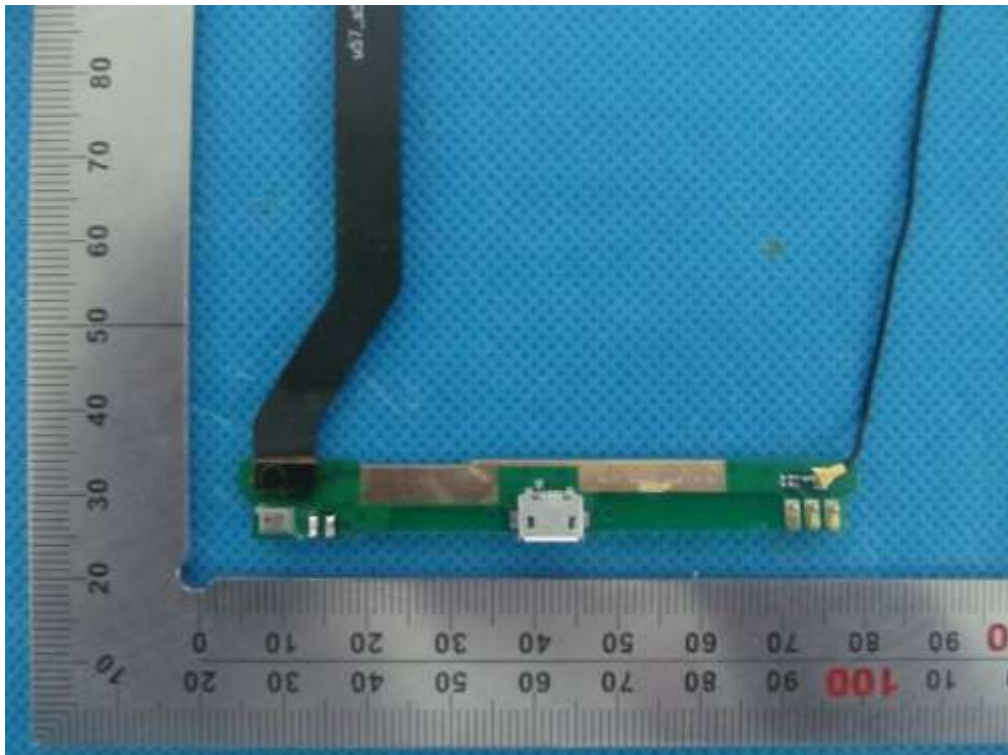

INTERNAL VIEW OF EUT-2

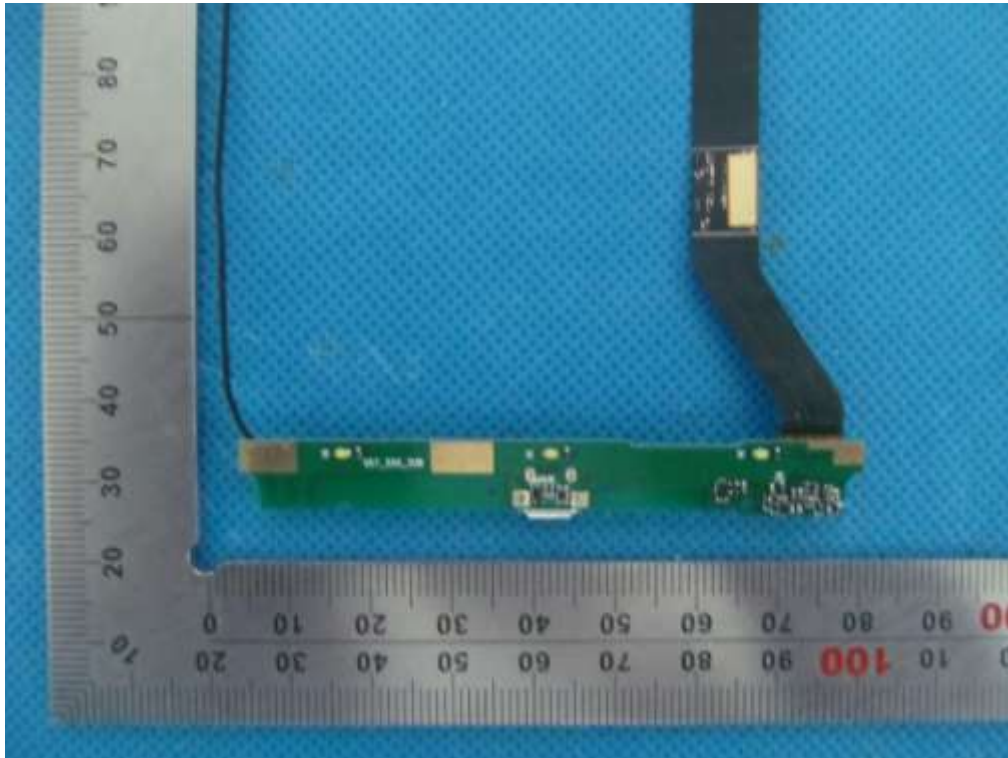

INTERNAL VIEW OF EUT-3



INTERNAL VIEW OF EUT-4

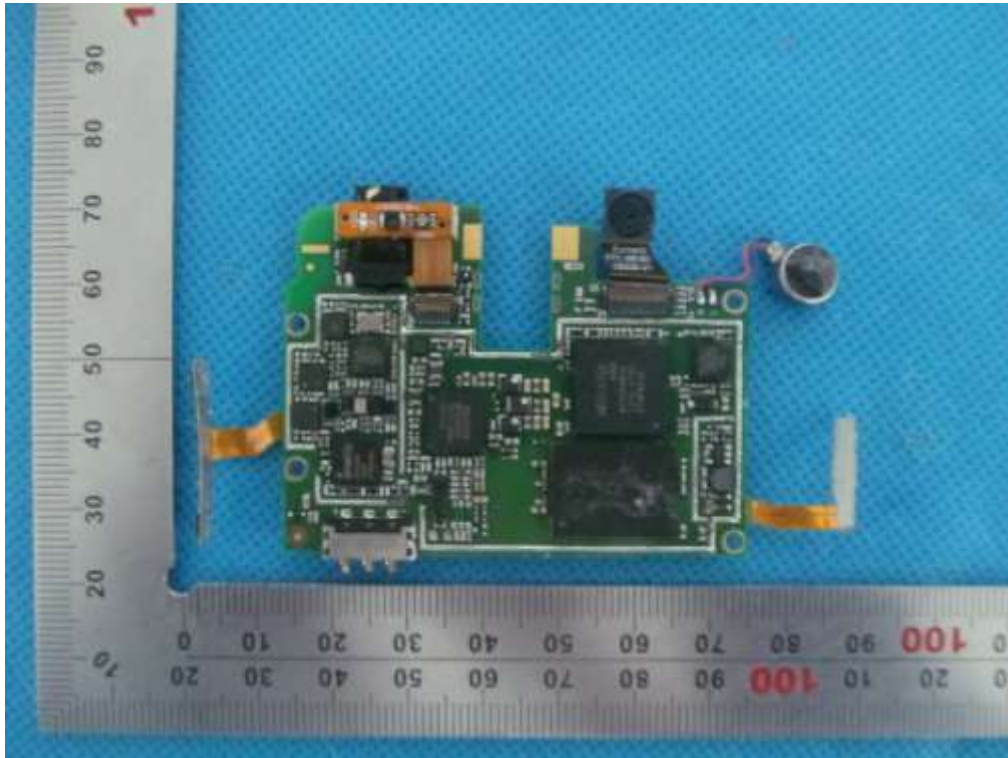

----END OF REPORT----