



FCC REPORT

Report Reference No...... : **TRE1612006304** R/C.....: 89392
FCC ID..... : **2AAA6-S471**
Applicant's name..... : **SENWA MEXICO,S.A.DE C.V**
Address..... : Av. Javier Barros Sierra 540,Torre I, Piso 5; COL. LOMAS DE SANTA FE DELEGACION ALVARO OBREGON C.P. 01210 MEXICO,DISTRITO FEDERAL
Manufacturer..... : Senwa Mobile HK ltd
Address..... : Room 910, International Trade Centre 11-19 Sha Tsui Road, Tsuen Wan, NT, HK
Test item description : Mobile Phone
Trade Mark : SENWA
Model/Type reference..... : S471
Listed Model(s) : -
Standard : **47 CFR FCC Part 15 Subpart B - Unintentional Radiators ANSI C63.4: 2014**
Date of receipt of test sample..... : Dec. 09, 2016
Date of testing..... : Dec. 09, 2016 - Dec. 16, 2016
Date of issue..... : Dec. 18, 2016
Result..... : **Pass**

Compiled by
 (position+printed name+signature)...: File administrators Becky Liang 
Supervised by
 (position+printed name+signature)...: Project Engineer Lion Cai 
Approved by
 (position+printed name+signature)...: RF Manager Hans Hu 

Testing Laboratory Name : **Shenzhen Huatongwei International Inspection Co., Ltd.**
Address..... : 1/F, Bldg 3, Hongfa Hi-tech Industrial Park, Genyu Road, Tianliao, Gongming, Shenzhen, China

Shenzhen Huatongwei International Inspection Co., Ltd. All rights reserved.

This publication may be reproduced in whole or in part for non-commercial purposes as long as the Shenzhen Huatongwei International Inspection Co., Ltd. is acknowledged as copyright owner and source of the material. Shenzhen Huatongwei International Inspection Co., Ltd. takes no responsibility for and will not assume liability for damages resulting from the reader's interpretation of the reproduced material due to its placement and context.

*The test report merely corresponds to the test sample.
 It is not permitted to copy extracts of these test result without the written permission of the test laboratory.*

Contents

1.	<u>TEST STANDARDS AND TEST DESCRIPTION</u>	3
1.1.	Test Standards	3
1.2.	Test Description	3
2.	<u>SUMMARY</u>	4
2.1.	Client Information	4
2.2.	Product Description	4
2.3.	EUT operation mode	5
2.4.	EUT configuration	5
2.5.	Configuration of Tested System	6
3.	<u>TEST ENVIRONMENT</u>	7
3.1.	Address of the test laboratory	7
3.2.	Test Facility	7
3.3.	Environmental conditions	8
3.4.	Statement of the measurement uncertainty	8
3.5.	Equipments Used during the Test	8
4.	<u>TEST CONDITIONS AND RESULTS</u>	9
4.1.	Conducted Emissions Test	9
4.2.	Radiated Emission Test	12
5.	<u>TEST SETUP PHOTOS OF THE EUT</u>	16
6.	<u>EXTERNAL AND INTERNAL PHOTOS OF THE EUT</u>	16

1. TEST STANDARDS AND TEST DESCRIPTION

1.1. Test Standards

The tests were performed according to following standards:

[47 CFR FCC Part 15 Subpart B](#) - Unintentional Radiators

[ANSI C63.4: 2014](#) – American National Standard for Methods of Measurement of Radio-Noise Emissions from Low-Voltage Electrical and Electronic Equipment in the Range of 9 kHz to 40GHz

1.2. Test Description

ReportSection	Test Item	FCC Rule	Result
4.1	Conducted Emissions Test	15.107	Pass
4.2	Radiated Emission Test	15.109	Pass

2. SUMMARY

2.1. Client Information

Applicant:	SENWA MEXICO,S.A.DE C.V
Address:	Av. Javier Barros Sierra 540,Torre I, Piso 5; COL. LOMAS DE SANTA FE DELEGACION ALVARO OBREGON C.P. 01210 MEXICO,DISTRITO FEDERAL
Manufacturer:	Senwa Mobile HK ltd
Address:	Room 910, International Trade Centre 11-19 Sha Tsui Road, Tsuen Wan, NT, HK

2.2. Product Description

Name of EUT	Mobile Phone
Trade Mark:	SENWA
Model No.:	S471
Listed Model(s):	-
IMEI :	352436080000995
Power supply:	DC 3.7V From internal battery
Adapter information:	Model: S471 Input: 100-240Va.c., 50-60Hz, 0.15A Output: 5Vd.c., 500mA

2.3. EUT operation mode

Test mode	Playing Video	Connect to PC (Down loading)	Camera	Adapter
1	■			■
2		■		
3			■	■

Note:

1. ■ is operation mode.

Pre-scan above all test mode, found below test mode which it was worse case mode.

Test item	Test mode (Worse case mode)
Conducted emission	Mode 2
Radiated emission	Mode 2

2.4. EUT configuration

The following peripheral devices and interface cables were connected during the measurement:

● - supplied by the manufacturer

○ - supplied by the lab

	Length (m) :	
	Shield :	
	Detachable :	
	Manufacturer :	
	Model No. :	-

2.5. Configuration of Tested System

Configuration of Tested System

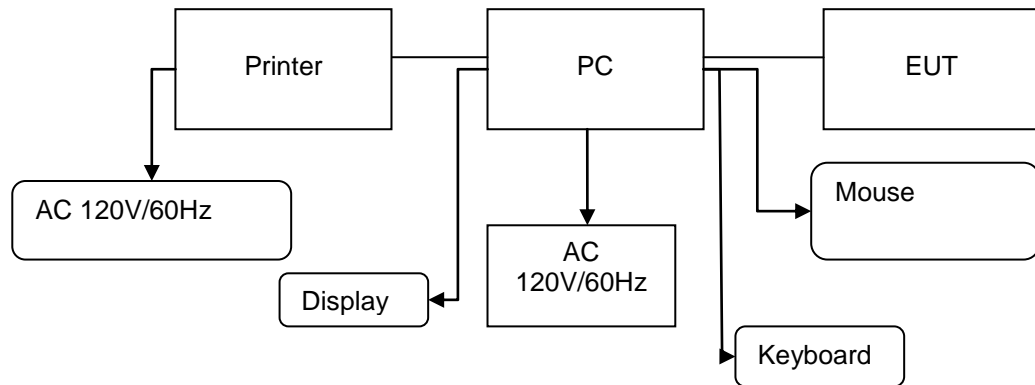

Equipment Used in Tested System

No.	Equipment	Manufacturer	Model No.	Serial No.	Length	shielded/unshielded	Notes
1	PC	DELL	DIMENSION E520	1RNN42X	/	/	DOC
2	Printer	ESPOn	C3990	C3990A	/	/	DOC
3	Mouse	DELL	MO56U OA	G0E02SY7	1.00m	unshielded	DOC
4	Display	DELL	1707FPt	CN-OFC237-71618-65G-AAKC	/	/	DOC
5	Keyboard	DELL	L100	CNRH65665890726009L	/	/	DOC
6	USB Cable (EUT to PC)	ITALCOM GROUP	USB 2.0	N/A	0.80m	unshielded	N/A
7	USB Cable (Printer to PC)	Genshuo	USB 2.0	N/A	1.20m	unshielded	N/A
8	Power line	/	/	N/A	1.00m	unshielded	N/A

3. TEST ENVIRONMENT

3.1. Address of the test laboratory

Laboratory: Shenzhen Huatongwei International Inspection Co., Ltd.

Address: 1/F, Bldg 3, Hongfa Hi-tech Industrial Park, Genyu Road, Tianliao, Gongming, Shenzhen, China

Phone: 86-755-26748019 Fax: 86-755-26748089

3.2. Test Facility

The test facility is recognized, certified, or accredited by the following organizations:

CNAS-Lab Code: L1225

Shenzhen Huatongwei International Inspection Co., Ltd. has been assessed and proved to be in compliance with CNAS-CL01 Accreditation Criteria for Testing and Calibration Laboratories

(identical to ISO/IEC17025: 2005 General Requirements) for the Competence of Testing and Calibration Laboratories, Date of Registration: February 28, 2015. Valid time is until February 27, 2018.

A2LA-Lab Cert. No. 3902.01

Shenzhen Huatongwei International Inspection Co., Ltd. EMC Laboratory has been accredited by A2LA for technical competence in the field of electrical testing, and proved to be in compliance with ISO/IEC 17025: 2005 General Requirements for the Competence of Testing and Calibration Laboratories and any additional program requirements in the identified field of testing. Valid time is until December 31, 2016.

FCC-Registration No.: 317478

Shenzhen Huatongwei International Inspection Co., Ltd. EMC Laboratory has been registered and fully described in a report filed with the FCC (Federal Communications Commission). The acceptance letter from the FCC is maintained in our files. Registration 317478, Renewal date Jul. 18, 2014, valid time is until Jul. 18, 2017.

IC-Registration No.: 5377A&5377B

The 3m Alternate Test Site of Shenzhen Huatongwei International Inspection Co., Ltd. has been registered by Certification and Engineering Bureau of Industry Canada for the performance of radiated measurements with Registration No. 5377A on Dec. 31, 2013, valid time is until Dec. 31, 2016.

Two 3m Alternate Test Site of Shenzhen Huatongwei International Inspection Co., Ltd. has been registered by Certification and Engineering Bureau of Industry Canada for the performance of radiated measurements with Registration No. 5377B on Dec.03, 2014, valid time is until Dec.03, 2017.

ACA

Shenzhen Huatongwei International Inspection Co., Ltd. EMC Laboratory can also perform testing for the Australian C-Tick mark as a result of our A2LA accreditation.

3.3. Environmental conditions

During the measurement the environmental conditions were within the listed ranges:

Temperature:	<u>15-35 ° C</u>
Humidity:	<u>30-60 %</u>
Atmospheric pressure:	<u>950-1050mbar</u>

3.4. Statement of the measurement uncertainty

The data and results referenced in this document are true and accurate. The reader is cautioned that there may be errors within the calibration limits of the equipment and facilities. The measurement uncertainty was calculated for all measurements listed in this test report acc. to CISPR 16 - 4 „Specification for radio disturbance and immunity measuring apparatus and methods – Part 4: Uncertainty in EMC Measurements“ and is documented in the Shenzhen Huatongwei International Inspection Co., Ltd quality system acc. to DIN EN ISO/IEC 17025. Furthermore, component and process variability of devices similar to that tested may result in additional deviation. The manufacturer has the sole responsibility of continued compliance of the device.

Hereafter the best measurement capability for Shenzhen Huatongwei laboratory is reported:

Test	Range	Measurement Uncertainty	Notes
Radiated Emission	30~1000MHz	4.24 dB	(1)
Radiated Emission	1~18GHz	5.16 dB	(1)
Radiated Emission	18-40GHz	5.54 dB	(1)
Conducted Disturbance	0.15~30MHz	3.39 dB	(1)

- (1) This uncertainty represents an expanded uncertainty expressed at approximately the 95% confidence level using a coverage factor of k=2.

3.5. Equipments Used during the Test

Conducted Emission					
Item	Test Equipment	Manufacturer	Model No.	Serial No.	Last Cal.
1	EMI TEST RECEIVER	Rohde & Schwarz	ESCI	100106	11/13/2016
2	ARTIFICIAL MAINS	Rohde & Schwarz	ESH2-Z5	100028	11/13/2016
3	PULSE LIMITER	Rohde & Schwarz	ESHSZ2	100044	11/13/2016
4	EMI TEST SOFTWARE	Rohde & Schwarz	ES-K1	N/A	N/A

Radiated Emission					
Item	Test Equipment	Manufacturer	Model No.	Serial No.	Last Cal.
1	ULTRA-BROADBAND ANTENNA	ShwarzBeck	VULB9163	538	11/13/2016
2	EMI TEST RECEIVER	Rohde & Schwarz	ESI 26	100009	11/13/2016
3	EMI TEST Software	Audix	E3	N/A	N/A
4	TURNTABLE	MATURO	TT2.0	----	N/A
5	ANTENNA MAST	MATURO	TAM-4.0-P	----	N/A
6	EMI TEST Software	Rohde & Schwarz	ESK1	N/A	N/A
7	ULTRA-BROADBAND ANTENNA	Rohde&Schwarz	HL562	100015	11/13/2016
8	Amplifier	Sonoma	310N	E009-13	11/13/2016
9	JS amplifier	Rohde & Schwarz	JS4-00101800-28-5A	F201504	11/13/2016
11	TURNTABLE	ETS	2088	2149	N/A
12	ANTENNA MAST	ETS	2075	2346	N/A
13	HORN ANTENNA	Rohde&Schwarz	HF906	100039	11/13/2016

The calibration interval was one year.

4. TEST CONDITIONS AND RESULTS

4.1. Conducted Emissions Test

TEST CONFIGURATION

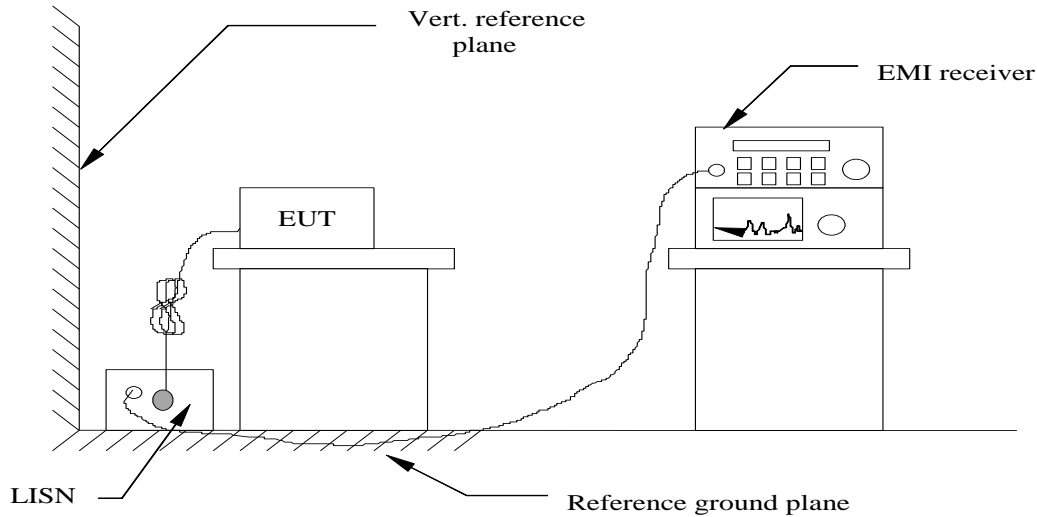

TEST PROCEDURE

1. The equipment was set up as per the test configuration to simulate typical actual usage per the user's manual. The EUT is a tabletop system; a wooden table with a height of 0.8 meters is used and is placed on the ground plane as per ANSI C63.4-2014.
2. Support equipment, if needed, was placed as per ANSI C63.4-2014
3. All I/O cables were positioned to simulate typical actual usage as per ANSI C63.4-2014.
4. The EUT received DC 5.0 from USB powered from AC120V/60Hz power through a Line Impedance Stabilization Network (LISN) which supplied power source and was grounded to the ground plane.
5. All support equipments received AC power from a second LISN, if any.
6. The EUT test program was started. Emissions were measured on each current carrying line of the EUT using a spectrum Analyzer / Receiver connected to the LISN powering the EUT. The LISN has two monitoring points: Line 1 (Hot Side) and Line 2 (Neutral Side). Two scans were taken: one with Line 1 connected to Analyzer / Receiver and Line 2 connected to a 50 ohm load; the second scan had Line 1 connected to a 50 ohm load and Line 2 connected to the Analyzer / Receiver.
7. Analyzer / Receiver scanned from 150 KHz to 30MHz for emissions in each of the test modes.
8. During the above scans, the emissions were maximized by cable manipulation.

CONDUCTED POWER LINE EMISSION LIMIT

For unintentional device, according to § 15.107(a) Line Conducted Emission Limits is as following :

Frequency (MHz)	Maximum RF Line Voltage (dBµV)			
	CLASS A		CLASS B	
	Q.P.	Ave.	Q.P.	Ave.
0.15 - 0.50	79	66	66-56*	56-46*
0.50 - 5.00	73	60	56	46
5.00 - 30.0	73	60	60	50

* Decreasing linearly with the logarithm of the frequency

TEST RESULTS

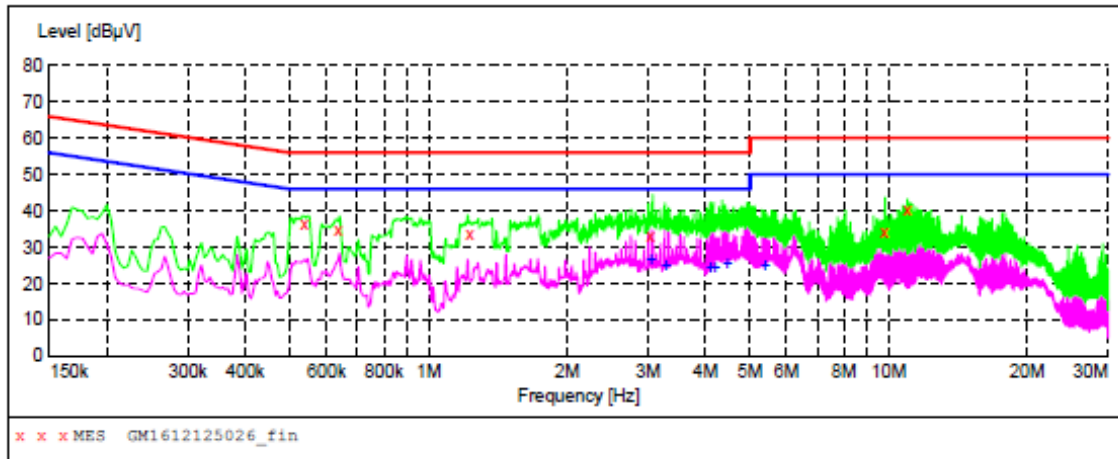

MEASUREMENT RESULT: "GM1612125026_fin"

12/12/2016 4:11PM

Frequency MHz	Level dBuV	Transd dB	Limit dBuV	Margin dB	Detector	Line	PE
0.537000	36.50	10.2	56	19.5	QP	L1	GND
0.636000	34.90	10.2	56	21.1	QP	L1	GND
1.230000	33.80	10.2	56	22.2	QP	L1	GND
3.043500	33.00	10.2	56	23.0	QP	L1	GND
9.802500	34.20	10.6	60	25.8	QP	L1	GND
11.004000	40.40	10.6	60	19.6	QP	L1	GND

MEASUREMENT RESULT: "GM1612125026_fin2"

12/12/2016 4:11PM

Frequency MHz	Level dBuV	Transd dB	Limit dBuV	Margin dB	Detector	Line	PE
3.039000	26.80	10.2	46	19.2	AV	L1	GND
3.282000	25.40	10.3	46	20.6	AV	L1	GND
4.092000	24.50	10.3	46	21.5	AV	L1	GND
4.200000	24.80	10.3	46	21.2	AV	L1	GND
4.456500	26.10	10.3	46	19.9	AV	L1	GND
5.379000	25.20	10.3	50	24.8	AV	L1	GND

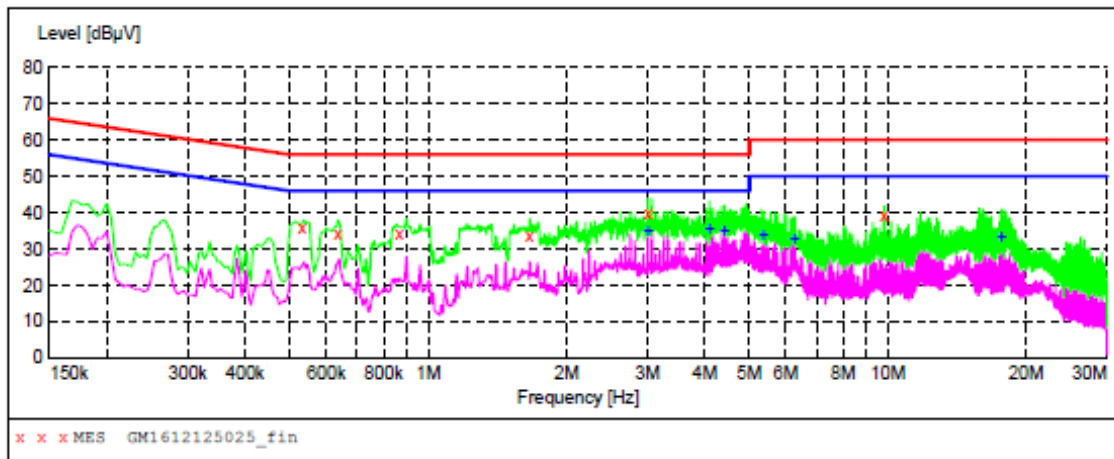

MEASUREMENT RESULT: "GM1612125025_fin"

12/12/2016 4:08PM

Frequency MHz	Level dBuV	Transd dB	Limit dBuV	Margin dB	Detector	Line	PE
0.532500	35.70	10.2	56	20.3	QP	N	GND
0.636000	34.40	10.2	56	21.6	QP	N	GND
0.865500	34.20	10.1	56	21.8	QP	N	GND
1.662000	33.60	10.2	56	22.4	QP	N	GND
3.007500	39.90	10.2	56	16.1	QP	N	GND
9.820500	39.30	10.6	60	20.7	QP	N	GND

MEASUREMENT RESULT: "GM1612125025_fin2"

12/12/2016 4:08PM

Frequency MHz	Level dBuV	Transd dB	Limit dBuV	Margin dB	Detector	Line	PE
3.007500	35.60	10.2	46	10.4	AV	N	GND
4.096500	36.10	10.3	46	9.9	AV	N	GND
4.416000	35.50	10.3	46	10.5	AV	N	GND
5.374500	34.10	10.3	50	15.9	AV	N	GND
6.270000	33.30	10.3	50	16.7	AV	N	GND
17.659500	33.80	10.5	50	16.2	AV	N	GND

Remark: Transd=Cable lose+ PULSE LIMITER factor+ ARTIFICIAL MAINS factor; Margin= Limit -Level

4.2. Radiated Emission Test

TEST CONFIGURATION

- a) Radiated Emission Test Set-Up, Frequency below 1000MHz

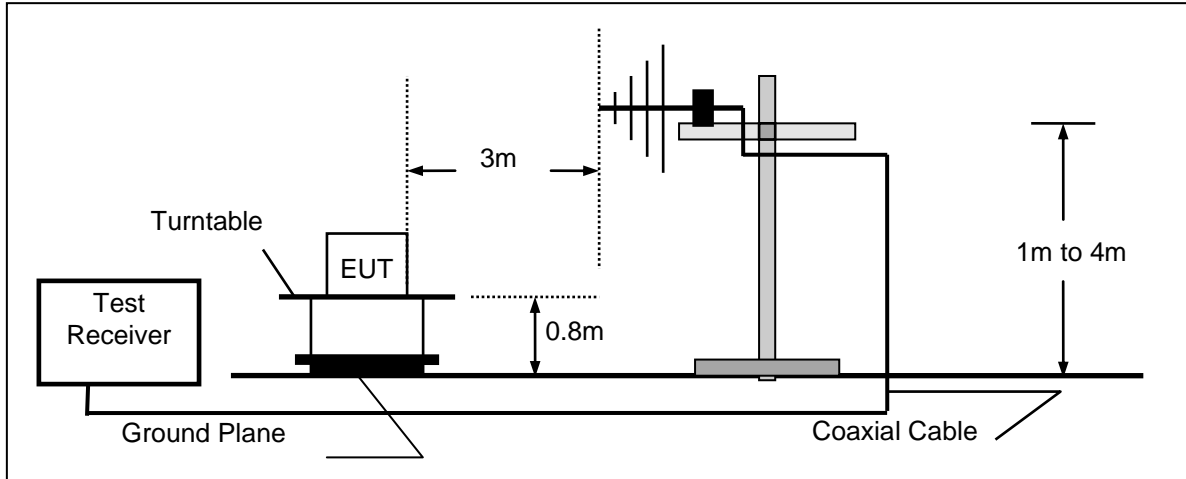

- b) Radiated Emission Test Set-Up, Frequency above 1000MHz

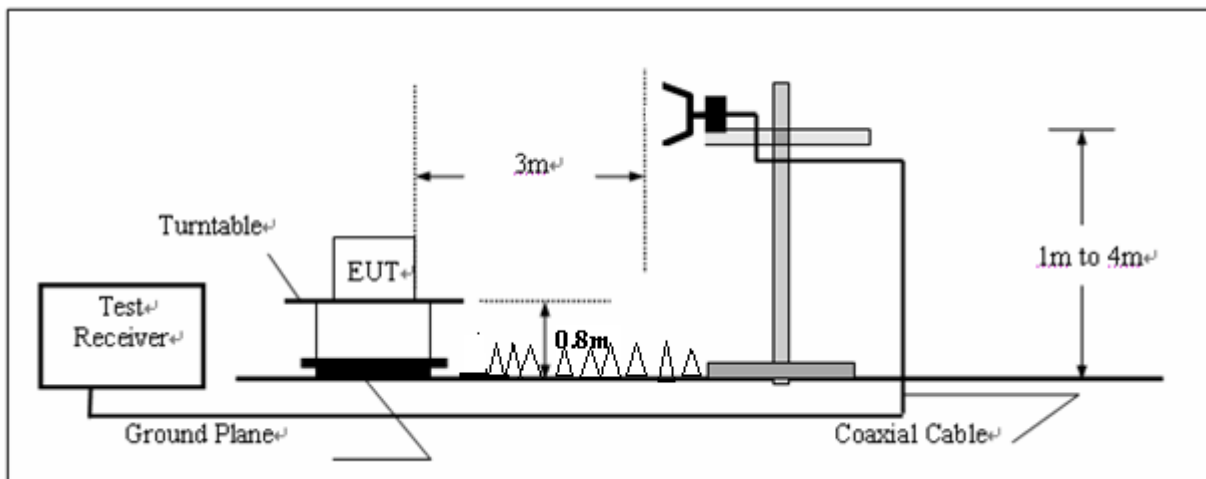

TEST PROCEDURE

1. The EUT is placed on a turntable, which is 0.8m above ground plane.
2. The turntable shall be rotated for 360 degrees to determine the position of maximum emission level.
3. EUT is set 3m away from the receiving antenna, which is varied from 1m to 4m to find out the highest emissions.
4. Maximum procedure was performed on the six highest emissions to ensure EUT compliance.
5. And also, each emission was to be maximized by changing the polarization of receiving antenna both horizontal and vertical.
6. Repeat above procedures until the measurements for all frequencies are complete.

FIELD STRENGTH CALCULATION

The field strength is calculated by adding the Antenna Factor and Cable Factor and subtracting the Amplifier Gain and Duty Cycle Correction Factor (if any) from the measured reading. The basic equation with a sample calculation is as follows:

$$FS = RA + AF + CL - AG$$

Where FS = Field Strength	CL = Cable Attenuation Factor (Cable Loss)
RA = Reading Amplitude	AG = Amplifier Gain
AF = Antenna Factor	

For example

Frequency (MHz)	FS (dB μ V/m)	RA (dB μ V/m)	AF (dB)	CL (dB)	AG (dB)	Transd (dB)
300.00	40	58.1	12.2	1.6	31.90	-18.1

$$\text{Transd} = \text{AF} + \text{CL} - \text{AG}$$

RADIATION LIMIT

For unintentional device, according to § 15.109(a), except for Class A digital devices, the field strength of radiated emissions from unintentional radiators at a distance of 3 meters shall not exceed the following values:

Frequency (MHz)	Distance (Meters)	Radiated (dB μ V/m)	Radiated (μ V/m)
30-88	3	40.0	100
88-216	3	43.5	150
216-960	3	46.0	200
Above 960	3	54.0	500

TEST RESULTS

Below1GHz

HORIZONTAL

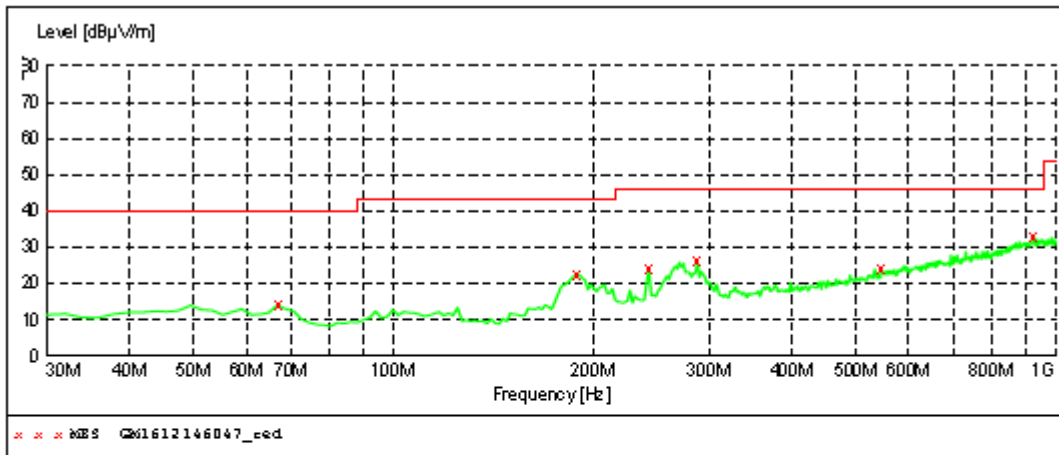

MEASUREMENT RESULT: "GM1612146047_red"

12/14/2016 4:12PM

Frequency MHz	Level dBµV/m	Transd dB	Limit dBµV/m	Margin dB	Det.	Height cm	Azimuth deg	Polarization
66.860000	14.10	-18.4	40.0	25.9	QP	300.0	91.00	HORIZONTAL
189.080000	22.50	-17.3	43.5	21.0	QP	100.0	221.00	HORIZONTAL
243.400000	23.90	-14.5	46.0	22.1	QP	100.0	109.00	HORIZONTAL
288.020000	26.10	-13.3	46.0	19.9	QP	100.0	306.00	HORIZONTAL
546.040000	24.20	-6.3	46.0	21.8	QP	300.0	11.00	HORIZONTAL
928.220000	32.70	1.4	46.0	13.3	QP	100.0	0.00	HORIZONTAL

VERTICAL

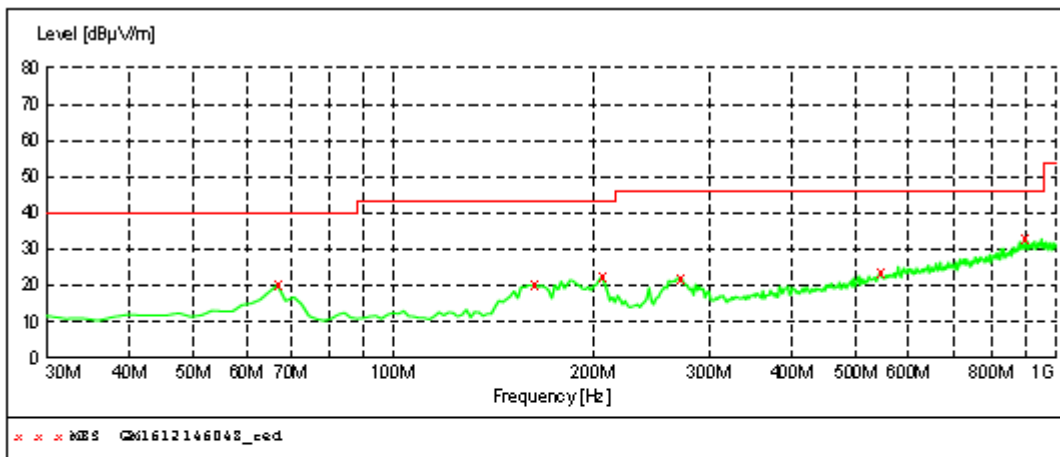

MEASUREMENT RESULT: "GM1612146048_red"

12/14/2016 4:14PM

Frequency MHz	Level dBµV/m	Transd dB	Limit dBµV/m	Margin dB	Det.	Height cm	Azimuth deg	Polarization
66.860000	20.00	-18.4	40.0	20.0	QP	100.0	206.00	VERTICAL
163.860000	20.10	-19.3	43.5	23.4	QP	100.0	0.00	VERTICAL
206.540000	22.40	-15.8	43.5	21.1	QP	100.0	270.00	VERTICAL
272.500000	22.00	-13.7	46.0	24.0	QP	100.0	206.00	VERTICAL
544.100000	23.70	-6.4	46.0	22.3	QP	100.0	254.00	VERTICAL
901.060000	32.90	1.2	46.0	13.1	QP	100.0	285.00	VERTICAL

Remark:Transd=Cable lose+ Antenna factor- Pre-amplifier;Margin=Limit -Level

Above 1GHz
HORIZONTAL

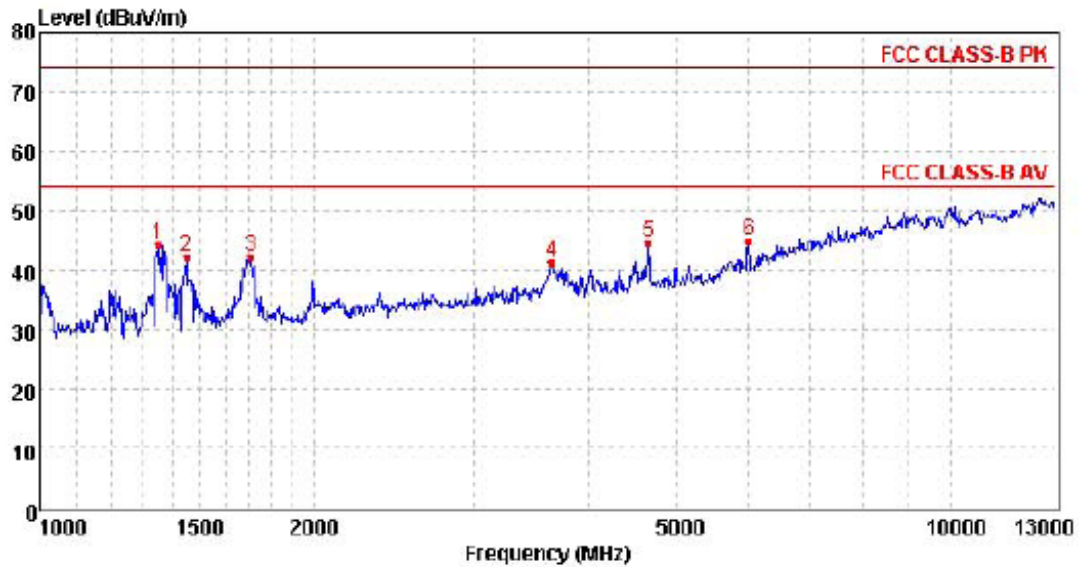

Mark	Frequency MHz	Reading dBuV/m	Antenna dB	Cable dB	Preamp dB	Level dBuV/m	Limit dBuV/m	Over limit	Remark
1	1349.99	51.30	24.57	4.91	36.49	44.29	74.00	-29.71	Peak
2	1450.51	49.07	24.66	5.14	36.53	42.34	74.00	-31.66	Peak
3	1704.91	47.93	25.33	5.77	36.94	42.09	74.00	-31.91	Peak
4	3652.09	42.32	28.96	8.33	38.26	41.35	74.00	-32.65	Peak
5	4659.79	41.38	31.00	9.48	37.15	44.71	74.00	-29.29	Peak
6	6006.85	36.46	33.20	10.68	35.44	44.90	74.00	-29.10	Peak

VERTICAL

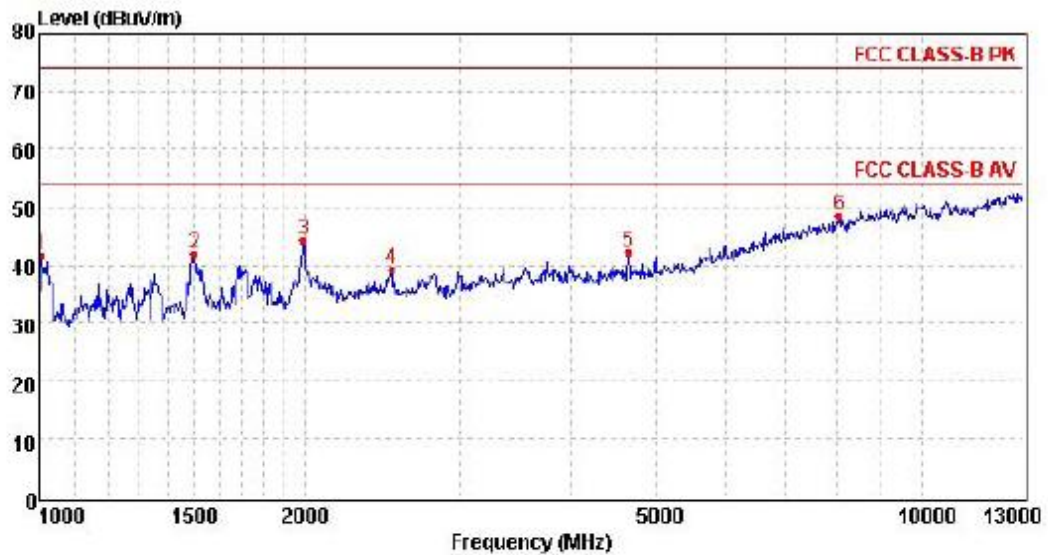

Mark	Frequency MHz	Reading dBuV/m	Antenna dB	Cable dB	Preamp dB	Level dBuV/m	Limit dBuV/m	Over limit	Remark
1	1007.73	49.79	24.21	4.23	36.67	41.56	74.00	-32.44	Peak
2	1499.70	48.65	24.70	5.28	36.59	42.04	74.00	-31.96	Peak
3	1993.66	49.25	26.09	6.26	37.29	44.31	74.00	-29.69	Peak
4	2504.91	42.44	27.91	6.84	37.87	39.32	74.00	-34.68	Peak
5	4647.85	38.97	31.00	9.48	37.17	42.28	74.00	-31.72	Peak
6	8047.04	33.83	36.75	12.41	34.53	48.46	74.00	-25.54	Peak

Remark: Level=Reading+ Antenna factor+cable lose- Pre-amplifier; Margin= Level- Limit

5. Test Setup Photos of the EUT

Conducted Emission Connect to PC



Radiated Emission (30MHz-1GHz) Connect to PC

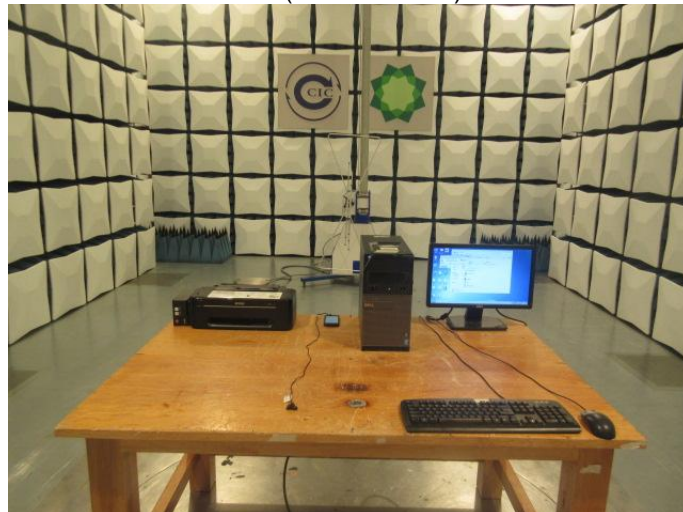

Radiated Emission (above 1GHz) Connect to PC

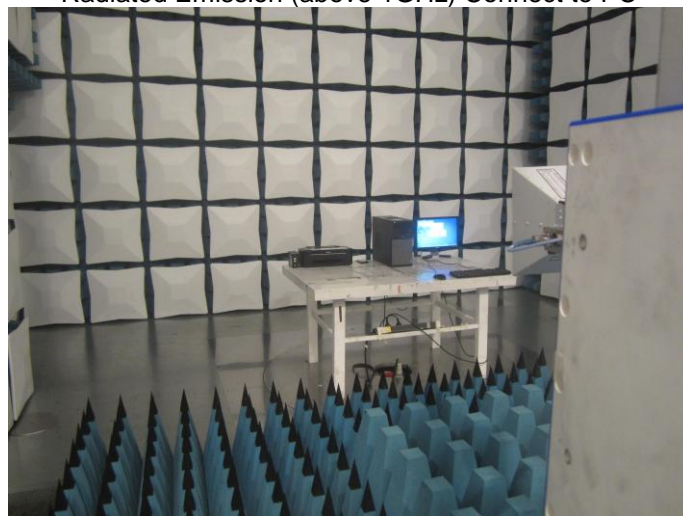

6. External and Internal Photos of the EUT

Reference to the test report No.: TRE1612006301.

.....**End of Report**.....