

Certification Test Report

FCC ID: 2AA9WV360
IC: 11665A-V360

FCC Rule Part: 15.247
IC Radio Standards Specification: RSS-210

ACS Report Number: 14-2101.W06.2A

Manufacturer: VSN Technologies, Inc.
Model: V360

Test Begin Date: **September 9, 2014**
Test End Date: **November 19, 2014**

Report Issue Date: November 20, 2014



FOR THE SCOPE OF ACCREDITATION UNDER CERTIFICATE NUMBER AT-1533

This report must not be used by the client to claim product certification, approval, or endorsement by ACCLASS, ANSI, or any agency of the Federal Government.

Reviewed by:

A handwritten signature in blue ink that reads "Thierry Jean-Charles".

Thierry Jean-Charles
EMC Engineer
Advanced Compliance Solutions, Inc.

This test report shall not be reproduced except in full. This report may be reproduced in part with prior written consent of ACS, Inc. The results contained in this report are representative of the sample(s) submitted for evaluation.

This report contains 20 pages

TABLE OF CONTENTS

1. GENERAL	3
1.1 Purpose	3
1.2 Manufacturer Information	3
1.3 Product Description.....	3
1.4 Test Methodology and Considerations	3
1 TEST FACILITIES	5
1.1 Location.....	5
1.2 Laboratory Accreditations/Recognitions/Certifications	5
1.3 Radiated & Conducted Emissions Test Site Description	6
2 APPLICABLE STANDARD REFERENCES.....	8
3 LIST OF TEST EQUIPMENT.....	9
4 SUPPORT EQUIPMENT	10
5 EQUIPMENT UNDER TEST SETUP BLOCK DIAGRAM	12
6 SUMMARY OF TESTS.....	13
6.1 Antenna Requirement – FCC: Section 15.203	13
6.2 Power Line Conducted Emissions – FCC: Section 15.207 IC: RSS-Gen 8.8.....	13
6.3 Band-Edge Compliance and Spurious Emissions-FCC 15.247(d) IC: RSS-210 A8.5.....	16
7 CONCLUSION.....	19

1. GENERAL

1.1 Purpose

The purpose of this report is to demonstrate compliance with Part 15 Subpart C of the FCC's Code of Federal Regulations and Industry Canada's Radio Standards Specification RSS-210 for the tests methods specified in this document.

1.2 Manufacturer Information

VSN Technologies, Inc.
1975 E. Sunrise Blvd., Suite 400
Fort Lauderdale, FL 33304

1.3 Product Description

The VSN Technologies model V360 is a high definition (HD) digital camera, with option for USB and HDMI connection. The product offers multiple wireless capabilities such as 2.4/5GHz 802.11b/g/n WLAN, Bluetooth 3.0 and Bluetooth Low Energy (BLE). There are two Bluetooth Low Energy sources on the product. One is located on the main board while the other is located on the daughter board. The BLE transceiver on the daughter board can transmit simultaneously with the transceiver on the main board for the WLAN, BLE and Bluetooth 3.0 modes of operation.

Technical Details

Mode of Operation:	Bluetooth 3.0 + Enhanced Data Rate (EDR)
Frequency Range:	2402 MHz - 2480 MHz
Number of Channels:	79
Channel Separation:	1 MHz
Modulations:	GFSK, $\pi/4$ -DQPSK, 8DPSK
TX Data Rates:	GFSK: 1Mbps $\pi/4$ -DQPSK: 2Mbps 8DPSK: 3Mbps
Antenna Type/Gain:	Monopole with Parasitic Antenna, 0.71 dBi
Input Power:	3.7V (Lithium Ion Battery), 5 VDC USB

Model Number: V360

Test Sample Serial Number(s): ACS#27, ACS#45

Test Sample Condition: The samples were in good conditions with no observable physical damages.

1.4 Test Methodology and Considerations

The EUT was evaluated for radiated and power line conducted emissions for the Bluetooth 3.0 + EDR radio located on the main transceiver board. The RF conducted emissions at the antenna port measurement results are documented in a separate test report.

For the evaluation, the EUT was set in the orientation of typical use. The radiated emissions were investigated up to the 10th harmonic. The configuration used for the evaluation is provided below. The EUT was also assessed for radiated emissions of intermodulation products for the BLE radio on the daughter board transmitting simultaneously with the Bluetooth 3.0 radio on the main transceiver board. All intermodulation products generated by the co-transmission of the co-located radios were found compliant to the limits of FCC Section 15.209.

Table 1.4-1: Bluetooth Radio Test configuration

Mode of Operations	Frequency (MHz)	Data Rate (kbps)
GFSK	2402	1000
	2441	1000
	2480	1000
$\pi/4$ DQPSK	2402	2000
	2441	2000
	2480	2000
8 DPSK	2402	3000
	2441	3000
	2480	3000

For the power line conducted emissions evaluation, preliminary testing was performed for the EUT powered via the laptop and for the EUT powered via the AC power supply. The input voltage to the AC power supply was set to both 120V/60Hz and 230V/50Hz. The final measurements were performed on the worst case configuration.

The unit was also evaluated for compliance to the unintentional emissions requirements. The results are documented separately in a DoC test report.

1 TEST FACILITIES

1.1 Location

The radiated and conducted emissions test sites are located at the following address:

Advanced Compliance Solutions, Inc.
3998 FAU Blvd, Suite 310
Boca Raton, Florida 33431
Phone: (561) 961-5585
Fax: (561) 961-5587
www.acstestlab.com

FCC Test Firm Registration #: 475089
Industry Canada Lab Code: 4175C

1.2 Laboratory Accreditations/Recognitions/Certifications

ACS is accredited to ISO/IEC 17025 by ANSI-ASQ National Accreditation Board under their ACLASS program and has been issued certificate number AT-1533 in recognition of this accreditation. Unless otherwise specified, all test methods described within this report are covered under the ISO/IEC 17025 scope of accreditation.

1.3 Radiated & Conducted Emissions Test Site Description

1.3.1 Semi-Anechoic Chamber Test Site

The EMC radiated test facility consists of an RF-shielded enclosure. The interior dimensions of the indoor semi-anechoic chamber are approximately 48 feet (14.6 m) long by 36 feet (10.8 m) wide by 24 feet (7.3 m) high and consist of rigid, 1/8 inch (0.32 cm) steel-clad, wood core modular panels with steel framing. In the shielded enclosure, the faces of the panels are galvanized and the chamber is self-supporting. 8-foot RF absorbing cones are installed on 4 walls and the ceiling. The steel-clad ground plane is covered with vinyl floor.

The turntable is driven by pneumatic motor, which is capable of supporting a 2000 lb. load. The turntable is flushed with the chamber floor which it is connected to, around its circumference, with a continuous metallic loaded spring. An EMCO Model 1050 Multi-device Controller controls the turntable position.

A pneumatic motor is used to control antenna polarizations and height relative to the ground. The height information is displayed on the control unit EMCO Model 1050.

The control room is an RF shielded enclosure attached to the semi-anechoic chamber with two bulkhead panels for connecting RF, and control cables. The dimension of the room is 7.3 m x 4.9 m x 3 m high and the entrance doors of both control and conducted rooms are 3 feet (0.91 m) by 7 feet (2.13 m).

A diagram of the Semi-Anechoic Chamber Test Site is shown in Figure 2.3.1-1 below:

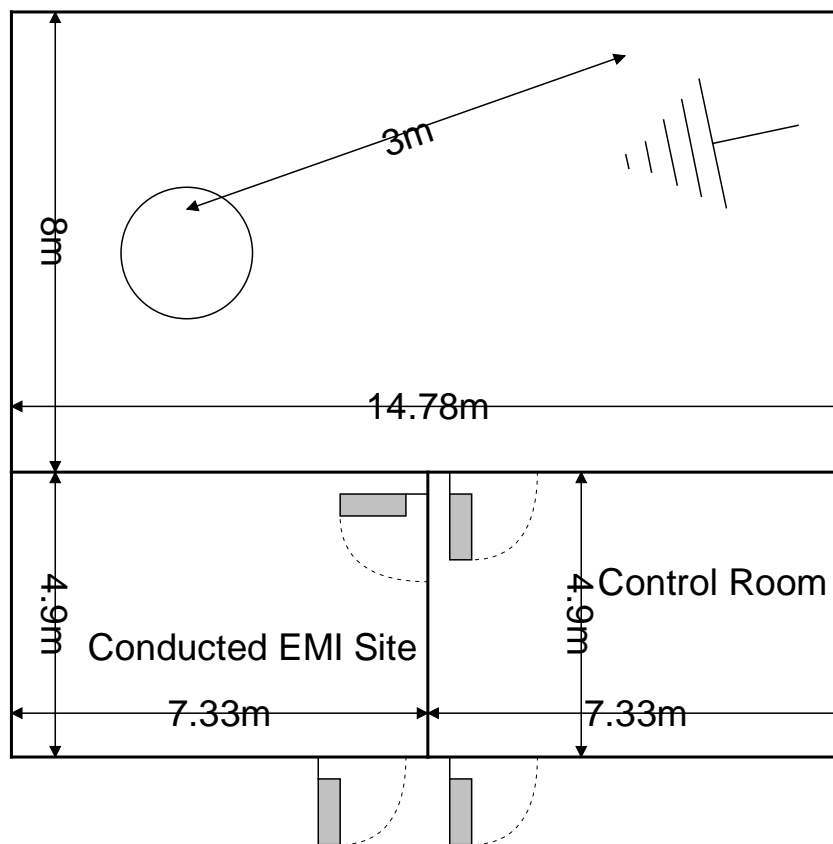

Figure 2.3.1-1: Semi-Anechoic Chamber Test Site

1.3.2 Conducted Emissions Test Site Description

The dimensions of the shielded conducted room are 7.3 x 4.9 x 3 m³. As per ANSI C63.4 2003 requirements, the data were taken using two LISNs; a Solar Model 8028-50 50 Ω/50 μH and an EMCO Model 3825, which are installed as shown in Photograph 3. For 220 V, 50 Hz, a Polarad LISN (S/N 879341/048) is used in conjunction with a 1 kVA, 50 Hz/220 V EDGAR variable frequency generator, Model 1001B, to filter conducted noise from the generator.

A diagram of the room is shown below in figure 2.3.2-1:

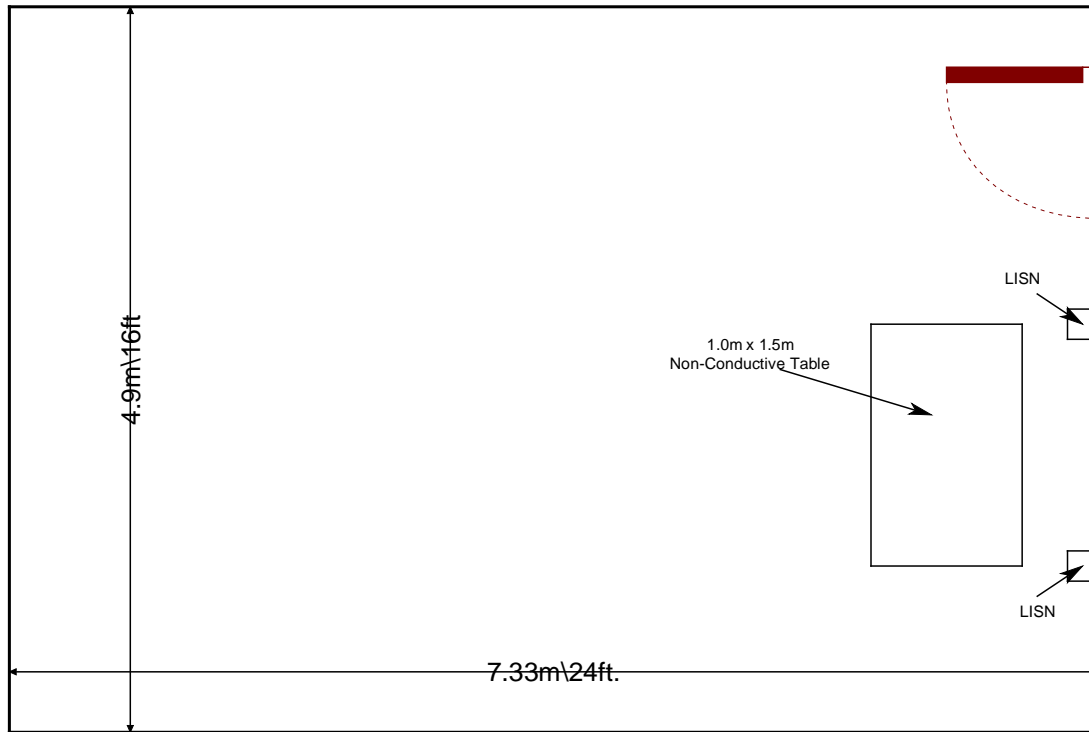

Figure 2.3.2-1: AC Mains Conducted EMI Site

2 APPLICABLE STANDARD REFERENCES

The following standards were used:

- ❖ ANSI C63.4-2003: Method of Measurements of Radio-Noise Emissions from Low-Voltage Electrical and Electronic Equipment in the 9KHz to 40GHz
- ❖ ANSI C63.10-2009: Standard for Testing Unlicensed Wireless Devices
- ❖ US Code of Federal Regulations (CFR): Title 47, Part 2, Subpart J: Equipment Authorization Procedures, 2014
- ❖ US Code of Federal Regulations (CFR): Title 47, Part 15, Subpart C: Radio Frequency Devices, Intentional Radiators, 2014
- ❖ FCC Public Notice DA 00-705 - Filing and Measurement Guidelines for Frequency Hopping Spread Spectrum Systems, March 30, 2000
- ❖ Industry Canada Radio Standards Specification: RSS-210 - Low-power License-exempt Radiocommunication Devices (All Frequency Bands): Category I Equipment, Issue 8 December 2010.
- ❖ Industry Canada Radio Standards Specification: RSS-GEN – General Requirements for Compliance of Radio Apparatus, Issue 4, November 2014.

3 LIST OF TEST EQUIPMENT

The calibration interval of test equipment is annually or the manufacturer's recommendations. Where the calibration interval deviates from the annual cycle based on the instrument manufacturer's recommendations, it shall be stated below.

Table 4-1: Test Equipment

AssetID	Manufacturer	Model #	Equipment Type	Serial #	Last Calibration Date	Calibration Due Date
523	Agilent	E7405	Spectrum Analyzers	MY45103293	1/8/2013	1/8/2015
2002	EMCO	3108	Antennas	2147	11/22/2013	11/22/2015
2004	EMCO	3146	Antennas	1385	11/22/2013	11/22/2015
2006	EMCO	3115	Antennas	2573	4/24/2013	4/24/2015
2008	COM-Power	AH-826	Antennas	81009	NCR	NCR
2011	Hewlett-Packard	HP 8447D	Amplifiers	2443A03952	12/31/2013	12/31/2014
2037	ACS Boca	Chamber EMI Cable Set	Cable Set	2037	2/27/2014	2/27/2015
2044	QMI	N/A	Cables	2044	12/31/2013	12/31/2014
2070	Mini Circuits	VHF-8400+	Filter	2070	1/1/2014	1/1/2015
2072	Mini Circuits	VHF-3100+	Filter	30737	1/1/2014	1/1/2015
2076	Hewlett Packard	HP5061-5458	Cables	2076	12/31/2013	12/31/2014
2086	Merrimac	FAN-6-10K	Attenuators	23148-83-1	12/31/2013	12/31/2014
2089	Agilent Technologies, Inc.	83017A	Amplifiers	3123A00214	12/16/2013	12/16/2014
2095	ETS Lindgren	TILE4! - Version 4.2.A	Software	85242	NCR	NCR
2022	EMCO	LISN3825/2R	LISN	1095	9/9/2013	9/9/2015
2045	ACS Boca	Conducted Cable Set	Cable Set	2045	1/1/2014	1/1/2015
3004	Teseq	CFL 9206A	Attenuators	34720	10/21/2013	10/21/2015

NCR=No Calibration Required

4 SUPPORT EQUIPMENT

Table 5-1: EUT and Support Equipment – Radiated Emissions

Item #	Type Device	Manufacturer or Responsible Party	Model/Part #	Serial #
1	EUT	VSN Technologies, Inc.	V360	ACS#45
2	Mount	VSN Technologies, Inc.	VN0214F16	ACS#46
3	Monitor	Samsung	S24D300HL	023EHCLF700344
4	Power Supply	Samsung	A2514_DSM	CN07BN4400719ASE38FSLY3RL
5	Laptop	Apple, Inc.	Macbook Pro A1278	C1MN2X3DTY3
6	Power Supply	Apple, Inc.	MagSafe	N/A
7	Mouse	Dell	M-UARDEL7	LZ9440C43W5

Table 5-2: Cable Description – Radiated Emissions

Cable #	Cable Type	Length	Shield	Termination
A	HDMI	1.80 m	Yes	EUT to Monitor
B	USB	1 m	Yes	EUT to Laptop
C	Power	1.50 m	No	Monitor to AC Adaptor
D	Power	1.80 m	No	Laptop to AC Adapter
E	Power	1.85 m	No	Power Supply to AC Mains
F	Power	1.58 m	No	Power Supply to AC Mains
G	USB	1.8m	No	Mouse to Laptop

Table 5-3: EUT and Support Equipment – Power Line Conducted Emissions

Item #	Type Device	Manufacturer or Responsible Party	Model/Part #	Serial #
1	EUT	VSN Technologies, Inc.	V360	ACS#27
2	Mount	VSN Technologies, Inc.	VN0214F16	ACS#46
3	Monitor	Samsung	S24D300HL	023EHCLF700344
4	Power Supply	Samsung	A2514_DSM	CN07BN4400719ASE38FSLY3RL
5	5V Power Supply	Danyang Chenyang Tech-Electron Co., LTD	C-P06	ACS#6

Table 5-4: Cable Description – Power Line Conducted Emissions

Cable #	Cable Type	Length	Shield	Termination
A	HDMI	1.80 m	Yes	EUT to Monitor
B	USB	1 m	Yes	EUT to Power Supply
C	Power	1.50 m	No	Monitor to Power Supply
D	Extension Cord	1.80 m	No	Power Supply to AC Mains
E	Power	1.85 m	No	Power Supply to AC Mains

5 EQUIPMENT UNDER TEST SETUP BLOCK DIAGRAM

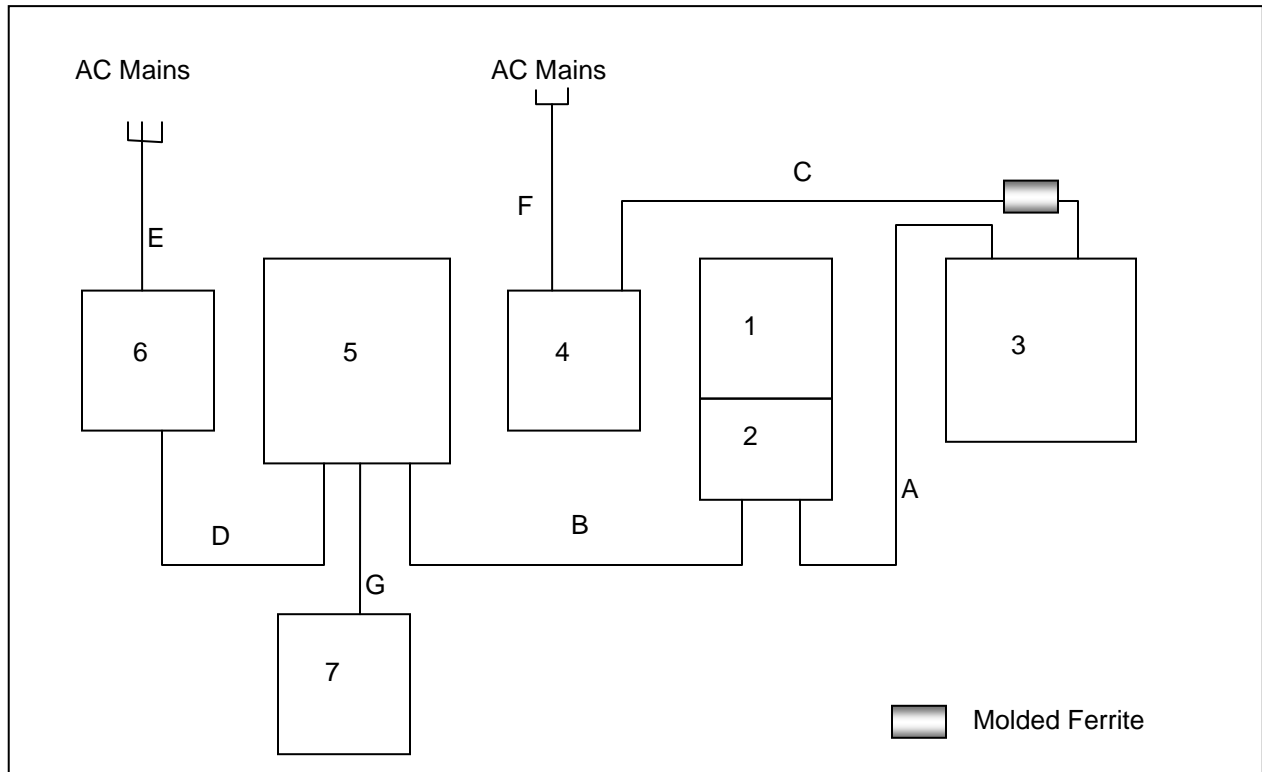

Figure 6-1: Test Setup – Radiated Emissions

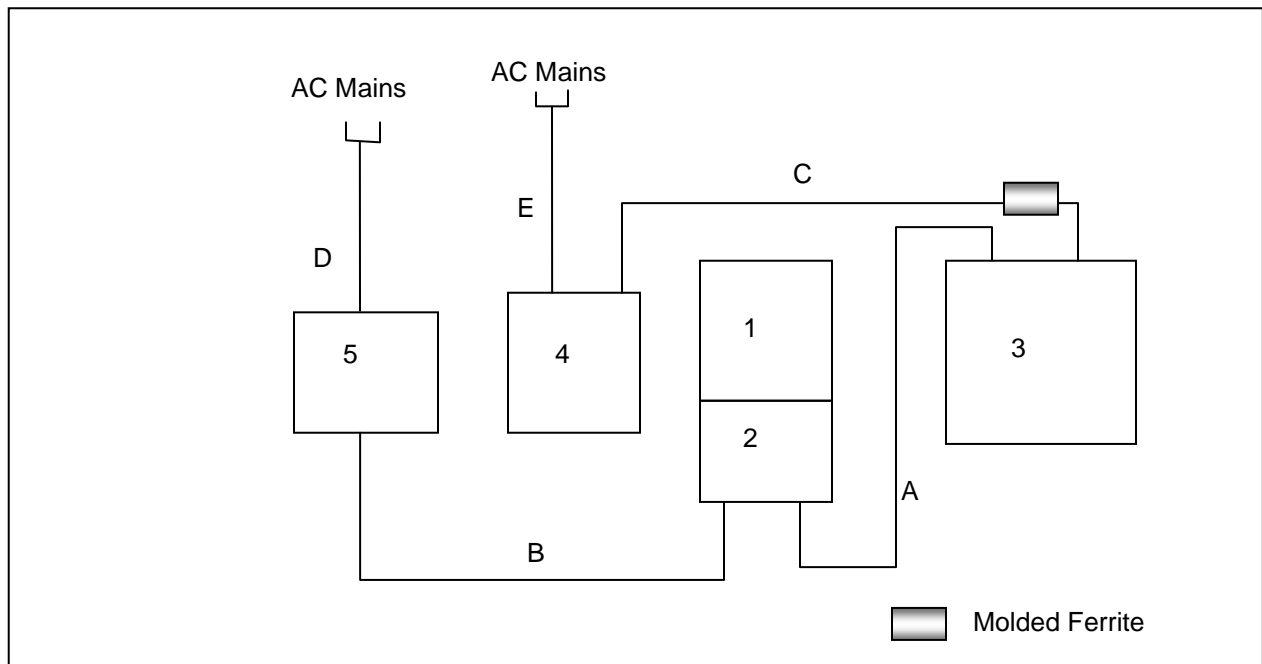

Figure 6-2: Test Setup – Power Line Conducted Emissions

6 SUMMARY OF TESTS

Along with the tabular data shown below, plots were taken of all signals deemed important enough to document.

6.1 Antenna Requirement – FCC: Section 15.203

The Bluetooth 3.0 radio uses a flexible monopole with parasitic antenna which is connected to the PCB via gold contacts. The antenna is internal to the product and is not easily replaceable, thus fulfilling the requirements of FCC Section 15.203.

6.2 Power Line Conducted Emissions – FCC: Section 15.207 IC: RSS-Gen 8.8

6.2.1 Measurement Procedure

ANSI C63.4 sections 6 and 7 were the guiding documents for this evaluation. Conducted emissions were performed from 150 kHz to 30 MHz with the spectrum analyzer's resolution bandwidth set to 9 kHz and the video bandwidth set to 30 kHz. The calculation for the conducted emissions is as follows:

Corrected Reading = Analyzer Reading + LISN Loss + Cable Loss
Margin = Applicable Limit - Corrected Reading

6.2.2 Measurement Results

Results of the test corresponding to the EUT configuration leading to the worse case emissions are shown below:

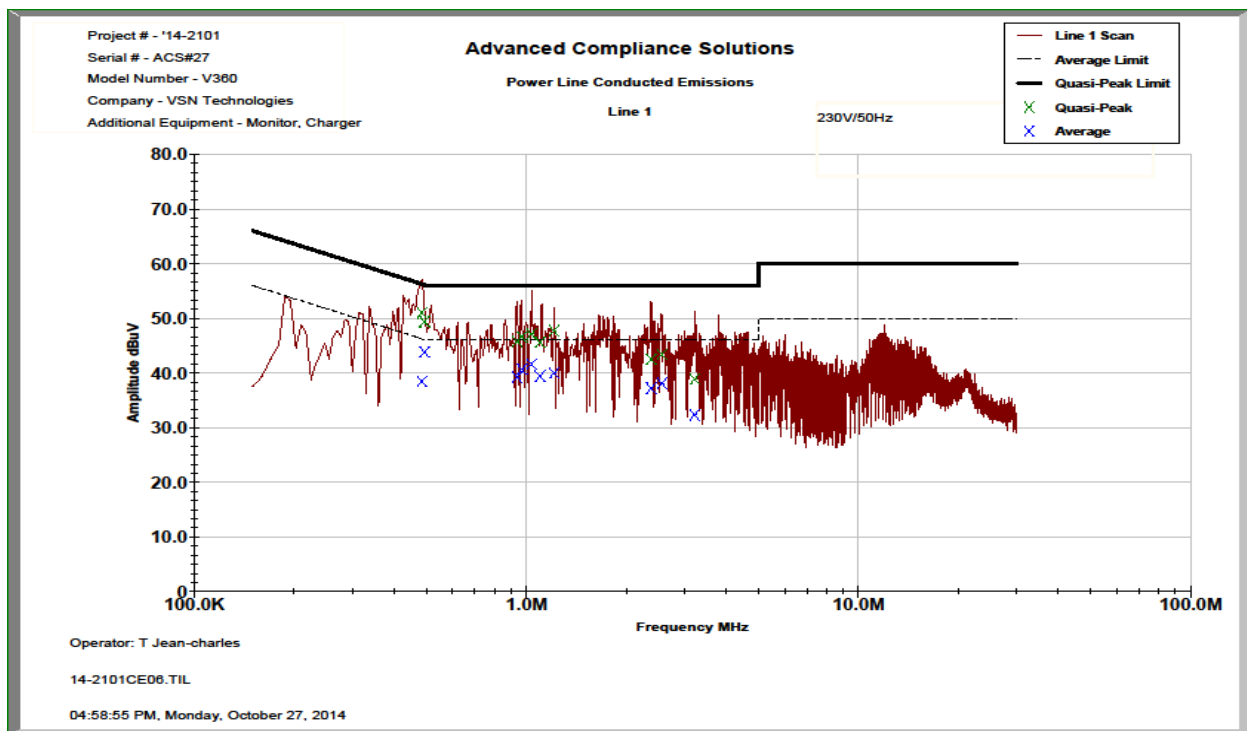

Figure 7.2.2-1: Conducted Emissions Results – Line 1

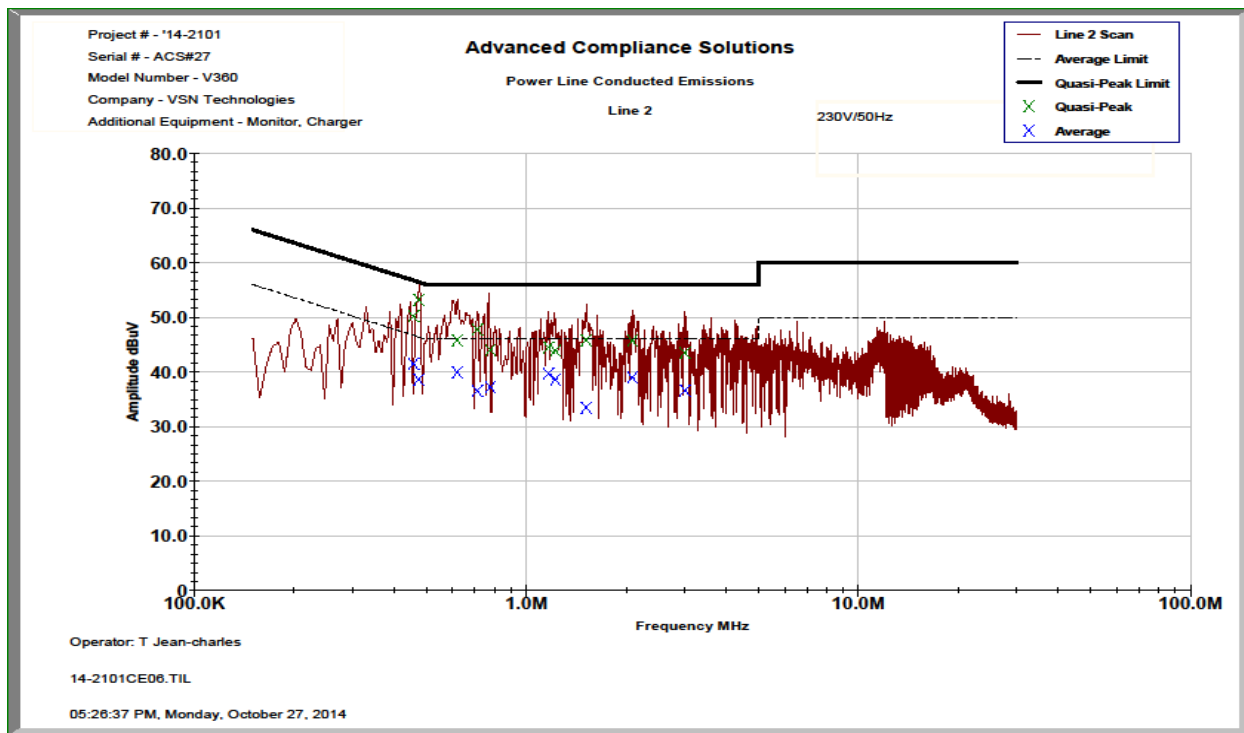

Figure 7.2.2-2: Conducted Emissions Results – Line 2

Table 7.2.2-1: Conducted EMI Results

Line 1 Line 2 Line 3
 Line 4
 To Ground Floating
 Telecom Port _____
 dBµV dBµA

 Plot Number: 14-2101CE06
 Power Supply Description: 5V DC

Frequency (MHz)	Uncorrected Reading		Total Correction Factor (dB)	Corrected Level		Limit		Margin (dB)	
	Quasi-Peak	Average		Quasi-Peak	Average	Quasi-Peak	Average	Quasi-Peak	Average
Line 1									
0.4855	40.91	28.36	10.08	50.99	38.44	56.24	46.24	5.3	7.8
0.494499	39.299	33.744	10.08	49.38	43.82	56.09	46.09	6.7	2.3
0.939963	35.709	29.134	10.09	45.80	39.22	56.00	46.00	10.2	6.8
0.972013	36.466	30.564	10.09	46.56	40.66	56.00	46.00	9.4	5.3
1.03984	37.006	31.507	10.11	47.12	41.62	56.00	46.00	8.9	4.4
1.10161	35.477	29.294	10.11	45.59	39.40	56.00	46.00	10.4	6.6
1.21459	37.564	29.875	10.11	47.67	39.98	56.00	46.00	8.3	6.0
2.38097	32.302	26.951	10.18	42.48	37.13	56.00	46.00	13.5	8.9
2.56193	33.169	27.861	10.18	43.35	38.04	56.00	46.00	12.7	8.0
Line 2									
0.4566	42.8	31.43	10.05	52.85	41.48	56.75	46.75	3.9	5.3
0.4753	43.158	28.58	10.05	53.21	38.63	56.42	46.42	3.2	7.8
0.620588	35.749	29.883	10.08	45.82	39.96	56.00	46.00	10.2	6.0
0.712438	37.68	26.45	10.07	47.75	36.52	56.00	46.00	8.2	9.5
0.780588	33.945	27.131	10.07	44.02	37.20	56.00	46.00	12.0	8.8
1.16775	34.442	29.566	10.08	44.52	39.64	56.00	46.00	11.5	6.4
1.22599	33.815	28.525	10.08	43.89	38.60	56.00	46.00	12.1	7.4
1.51599	35.712	23.356	10.08	45.79	33.43	56.00	46.00	10.2	12.6
2.08976	35.54	28.846	10.14	45.68	38.98	56.00	46.00	10.3	7.0
3.00924	33.249	26.397	10.195	43.44	36.59	56.00	46.00	12.6	9.4

6.3 Band-Edge Compliance and Spurious Emissions-FCC 15.247(d) IC: RSS-210 A8.5

6.3.1 Radiated Spurious Emissions within the Restricted Bands - FCC Section 15.205, Section 15.209; IC: RSS-Gen 8.9, 8.10

6.3.1.1 Measurement Procedure

Radiated emissions tests were made over the frequency range of 30 MHz to 26 GHz, 10 times the highest fundamental frequency. Each emission found to be in a restricted band, as defined by FCC section 15.205 and RSS-Gen 8.10, was compared to the radiated emission limits defined in FCC Section 15.209 and RSS-Gen 8.9.

The EUT was rotated through 360° and the receive antenna height was varied from 1m to 4m so that the maximum radiated emissions level would be detected. For frequencies below 1000MHz, quasi-peak measurements were made using a resolution bandwidth RBW of 120 kHz and a video bandwidth VBW of 300 kHz. For frequencies above 1000 MHz, peak and average measurements made with RBW and VBW of 1 MHz and 3 MHz respectively.

The EUT was caused to generate a continuous carrier signal on the hopping channel.

6.3.1.2 Measurement Results

Radiated spurious emissions found in the restricted frequency bands of 30MHz to 26 GHz are reported in the tables below.

Table 7.3.1.2-1: Radiated Spurious Emissions Tabulated Data - GFSK

Frequency (MHz)	Level (dBuV)		Antenna Polarity (H/V)	Correction Factors (dB)	Corrected Level (dBuV/m)		Limit (dBuV/m)		Margin (dB)	
	pk	Qpk/Avg			pk	Qpk/Avg	pk	Qpk/Avg	pk	Qpk/Avg
Low Channel 2402 MHz										
All emissions in the restricted bands were attenuated below the limits and the noise floor										
Middle Channel 2441 MHz										
7323	48.62	41.92	H	5.59	54.21	47.51	74.0	54.0	19.8	6.5
7323	49.68	43.62	V	5.59	55.27	49.21	74.0	54.0	18.7	4.8
High Channel 2480 MHz										
2483.5	58.84	48.50	H	-7.61	51.23	40.89	74.0	54.0	22.8	13.1
2483.5	59.68	51.08	V	-7.61	52.07	43.47	74.0	54.0	21.9	10.5
7440	48.92	42.65	H	6.00	54.92	48.65	74.0	54.0	19.1	5.4
7440	50.42	45.27	V	6.00	56.42	51.27	74.0	54.0	17.6	2.7

Note:

All emissions above 7.44 GHz were attenuated below the limits and the noise floor of the measurement equipment.

Table 7.3.1.2-2: Radiated Spurious Emissions Tabulated Data – ($\pi/4$) DQPSK

Frequency (MHz)	Level (dBuV)		Antenna Polarity (H/V)	Correction Factors (dB)	Corrected Level (dBuV/m)		Limit (dBuV/m)		Margin (dB)	
	pk	Qpk/Avg			pk	Qpk/Avg	pk	Qpk/Avg	pk	Qpk/Avg
Low Channel 2402 MHz										
All emissions in the restricted bands were attenuated below the limits and the noise floor										
Middle Channel 2441 MHz										
7323	49.40	42.95	H	5.59	54.99	48.54	74.0	54.0	19.0	5.5
7323	50.99	45.22	V	5.59	56.58	50.81	74.0	54.0	17.4	3.2
High Channel 2480 MHz										
2483.5	59.74	52.64	H	-7.61	52.13	45.03	74.0	54.0	21.9	9.0
2483.5	60.90	55.87	V	-7.61	53.29	48.26	74.0	54.0	20.7	5.7
7440	47.70	40.40	H	6.00	53.70	46.40	74.0	54.0	20.3	7.6
7440	49.44	43.71	V	6.00	55.44	49.71	74.0	54.0	18.6	4.3

Note:

All emissions above 7.44 GHz were attenuated below the limits and the noise floor of the measurement equipment.

Table 7.3.1.2-3: Radiated Spurious Emissions Tabulated Data – 8DPSK

Frequency (MHz)	Level (dBuV)		Antenna Polarity (H/V)	Correction Factors (dB)	Corrected Level (dBuV/m)		Limit (dBuV/m)		Margin (dB)	
	pk	Qpk/Avg			pk	Qpk/Avg	pk	Qpk/Avg	pk	Qpk/Avg
Low Channel 2402 MHz										
All emissions in the restricted bands were attenuated below the limits and the noise floor										
Middle Channel 2441 MHz										
7323	49.32	41.94	H	5.59	54.91	47.53	74.0	54.0	19.1	6.5
7323	50.24	44.03	V	5.59	55.83	49.62	74.0	54.0	18.2	4.4
High Channel 2480 MHz										
2483.5	61.37	55.58	H	-7.61	53.76	47.97	74.0	54.0	20.2	6.0
2483.5	62.73	58.57	V	-7.61	55.12	50.96	74.0	54.0	18.9	3.0
7440	47.19	40.04	H	6.00	53.19	46.04	74.0	54.0	20.8	8.0
7440	49.07	43.75	V	6.00	55.07	49.75	74.0	54.0	18.9	4.3

Note:

All emissions above 7.44 GHz were attenuated below the limits and the noise floor of the measurement equipment.

6.3.1.3 Sample Calculation:

$$R_C = R_U + CF_T$$

Where:

CF_T	=	Total Correction Factor (AF+CA+AG)-DC (Average Measurements Only)
R_U	=	Uncorrected Reading
R_C	=	Corrected Level
AF	=	Antenna Factor
CA	=	Cable Attenuation
AG	=	Amplifier Gain
DC	=	Duty Cycle Correction Factor

Example Calculation: Peak

Corrected Level: $48.62 + 5.59 = 54.21$ dB μ V/m

Margin: 74 dB μ V/m – 54.21 dB μ V/m = 19.8 dB

Example Calculation: Average

Corrected Level: $41.92 + 5.59 = 47.51$ dB μ V/m

Margin: 54 dB μ V/m – 47.51 dB μ V/m = 6.5 dB

7 CONCLUSION

In the opinion of ACS, Inc., the V360 manufactured by VSN Technologies, Inc. meets the requirements of FCC Part 15 subpart C and Industry Canada's Radio Standards Specification RSS-210 for the tests documented in this report.

END REPORT