



TEST REPORT

Test Report No. : UL-RPT-RP11401108JD05A

Manufacturer : FIBAR GROUP SA
Model No. : FGBHMS-001
FCC ID : 2AA9MFGBHMS001
Technology : *Bluetooth* – Low Energy
Test Standard(s) : FCC Parts 15.209(a) & 15.247

1. This test report shall not be reproduced in full or partial, without the written approval of UL VS LTD.
2. The results in this report apply only to the sample(s) tested.
3. The sample tested is in compliance with the above standard(s).
4. The test results in this report are traceable to the national or international standards.
5. Version 1.0.

Date of Issue: 17 October 2016

Checked by:

Ian Watch
Senior Engineer, Radio Laboratory

Company Signatory:

Steven White
Service Lead, Radio Laboratory
UL VS LTD



This laboratory is accredited by UKAS. The tests reported herein have been performed in accordance with its terms of accreditation.

The *Bluetooth*[®] word mark and logos are owned by the *Bluetooth* SIG, Inc. and any use of such marks by UL VS LTD is under licence. Other trademarks and trade names are those of their respective owners.

UL VS LTD

Pavilion A, Ashwood Park, Ashwood Way, Basingstoke, Hampshire, RG23 8BG, UK
Telephone: +44 (0)1256 312000
Facsimile: +44 (0)1256 312001

This page has been left intentionally blank.

Table of Contents

1. Customer Information..... 4

2. Summary of Testing..... 5

 2.1. General Information 5

 2.2. Summary of Test Results 5

 2.3. Methods and Procedures 5

 2.4. Deviations from the Test Specification 5

3. Equipment Under Test (EUT) 6

 3.1. Identification of Equipment Under Test (EUT) 6

 3.2. Description of EUT 6

 3.3. Modifications Incorporated in the EUT 6

 3.4. Additional Information Related to Testing 7

 3.5. Support Equipment 7

4. Operation and Monitoring of the EUT during Testing 8

 4.1. Operating Modes 8

 4.2. Configuration and Peripherals 8

5. Measurements, Examinations and Derived Results 9

 5.1. General Comments 9

 5.2. Test Results 10

 5.2.1. Transmitter Minimum 6 dB Bandwidth 10

 5.2.2. Transmitter Maximum Peak Output Power 13

 5.2.3. Transmitter Radiated Emissions 16

 5.2.4. Transmitter Band Edge Radiated Emissions 22

6. Measurement Uncertainty26

7. Report Revision History27

1. Customer Information







Company Name:	FIBAR GROUP SA
Address:	Ul Lotnicza 1 Poznan 60-421 Poland

2. Summary of Testing

2.1. General Information

Specification Reference:	47CFR15.247
Specification Title:	Code of Federal Regulations Volume 47 (Telecommunications): Part 15 Subpart C (Intentional Radiators) - Section 15.247
Specification Reference:	47CFR15.209
Specification Title:	Code of Federal Regulations Volume 47 (Telecommunications): Part 15 Subpart C (Intentional Radiators) – Section 15.209
Site Registration:	209735
Location of Testing:	UL VS LTD, Unit 3 Horizon, Wade Road, Kingsland Business Park, Basingstoke, Hampshire, RG24 8AH, United Kingdom
Test Dates:	23 September 2016 to 10 October 2016

2.2. Summary of Test Results

FCC Reference (47CFR)	Measurement	Result
Part 15.247(a)(2)	Transmitter Minimum 6 dB Bandwidth	
Part 15.247(e)	Transmitter Power Spectral Density	Note 1
Part 15.247(b)(3)	Transmitter Maximum Peak Output Power	
Part 15.247(d)/15.209(a)	Transmitter Radiated Emissions	
Part 15.247(d)/15.209(a)	Transmitter Band Edge Radiated Emissions	
Key to Results		
 = Complied  = Did not comply		

Note(s):

- In accordance with FCC KDB 558074 Section 10.1, PSD is not required if the maximum conducted output power is less than the PSD limit of 8 dBm / 3 kHz. The PSD level is therefore deemed to be equal to the measured total output power.

2.3. Methods and Procedures

Reference:	ANSI C63.10-2013
Title:	American National Standard of Procedures for Compliance Testing of Unlicensed Wireless Devices
Reference:	KDB 558074 D01 DTS Meas Guidance v03r05 April 8, 2016
Title:	Guidance for Performing Compliance Measurements on Digital Transmission Systems (DTS) Operating Under §15.247

2.4. Deviations from the Test Specification

For the measurements contained within this test report, there were no deviations from, additions to, or exclusions from the test specification identified above.

3. Equipment Under Test (EUT)

3.1. Identification of Equipment Under Test (EUT)

Brand Name:	Fibaro
Model Name or Number:	FGBHMS-001
Test Sample Serial Number:	#1 (<i>Radiated sample</i>)
Hardware Version:	v1.1.A
Software Version:	1.0.0
FCC ID:	2AA9MFGBHMS001

Brand Name:	Fibaro
Model Name or Number:	FGBHMS-001
Test Sample Serial Number:	#2 (<i>Conducted sample with RF port</i>)
Hardware Version:	v1.1.A
Software Version:	1.0.0
FCC ID:	2AA9MFGBHMS001

3.2. Description of EUT

The Equipment Under Test was a Motion Sensor with *Bluetooth* Low Energy radio. It contains a 3 Volt CR123A battery.

3.3. Modifications Incorporated in the EUT

No modifications were applied to the EUT during testing.

3.4. Additional Information Related to Testing

Technology Tested:	<i>Bluetooth</i> Low Energy (Digital Transmission System)		
Type of Unit:	Transceiver		
Channel Spacing:	2 MHz		
Modulation:	GFSK		
Data Rate:	1 Mbps		
Power Supply Requirement(s):	Nominal	3.0 VDC	
Antenna Gain:	3.0 dBi		
Transmit Frequency Range:	2402 MHz to 2480 MHz		
Transmit Channels Tested:	Channel ID	RF Channel	Channel Frequency (MHz)
	Bottom	0	2402
	Middle	19	2440
	Top	39	2480

3.5. Support Equipment

The following support equipment was used to exercise the EUT during testing:

Description:	Laptop PC
Brand Name:	Lenovo ThinkPad
Model Name or Number:	L440
Serial Number:	R9-019EA4

Description:	USB to UART Converter
Brand Name:	Inhaos
Model Name or Number:	UC-3100P
Serial Number:	Not marked or stated

4. Operation and Monitoring of the EUT during Testing

4.1. Operating Modes

The EUT was tested in the following operating mode(s):

- Transmitting in *Bluetooth* LE test mode at maximum power on bottom, middle or top channel as required.

4.2. Configuration and Peripherals

The EUT was tested in the following configuration(s):

- A laptop PC with an open source terminal application RealTerm 2.0.0.70 was used to place the EUT into *Bluetooth* LE test mode. Operating channels were configured in the test application following instructions provided by the customer. To enable control of the *Bluetooth* LE radio during testing, three cables of ~20 cm in length were soldered to the EUT internal PCB by the customer. A section of the external plastic housing of the EUT was removed to allow the cables to exit and make a connection to a UART to USB convertor cable, which then connected to a laptop PC. The cables remained in-situ for all testing.
- The customer supplied an RF cable for connection to the EUT in order to perform conducted measurements. The path losses were measured and accounted for as an RF level offset in the measurements where required.
- Radiated spurious emissions were performed with the EUT in 3 orientations to determine the worst case. There were no ports on the EUT to terminate.
- The EUT with Serial No. #1 was used for all radiated tests. The EUT with Serial No. #2 was used for all conducted tests.

5. Measurements, Examinations and Derived Results

5.1. General Comments

Measurement uncertainties are evaluated in accordance with current best practice. Our reported expanded uncertainties are based on standard uncertainties, which are multiplied by an appropriate coverage factor to provide a statistical confidence level of approximately 95%. Please refer to *Section 6. Measurement Uncertainty* for details.

In accordance with UKAS requirements all the measurement equipment is on a calibration schedule. All equipment was within the calibration period on the date of testing.

5.2. Test Results

5.2.1. Transmitter Minimum 6 dB Bandwidth

Test Summary:

Test Engineer:	Stefan Ho	Test Date:	23 September 2016
Test Sample Serial Number:	#2		

FCC Reference:	Part 15.247(a)(2)
Test Method Used:	FCC KDB 558074 Section 8.1 Option 1

Environmental Conditions:

Temperature (°C):	25
Relative Humidity (%):	43

Note(s):

1. 6 dB DTS bandwidth tests were performed using a signal analyser in accordance with FCC KDB 558074 Section 8.1 Option 1 measurement procedure. The signal analyser resolution bandwidth was set to 100 kHz and video bandwidth 300 kHz. A peak detector was used, sweep time was set to auto and the trace mode was Max Hold. The DTS bandwidth was measured at 6 dB down from the peak of the signal.
2. The signal analyser was connected to the RF port on the EUT using suitable attenuation and RF cable.

Test setup:

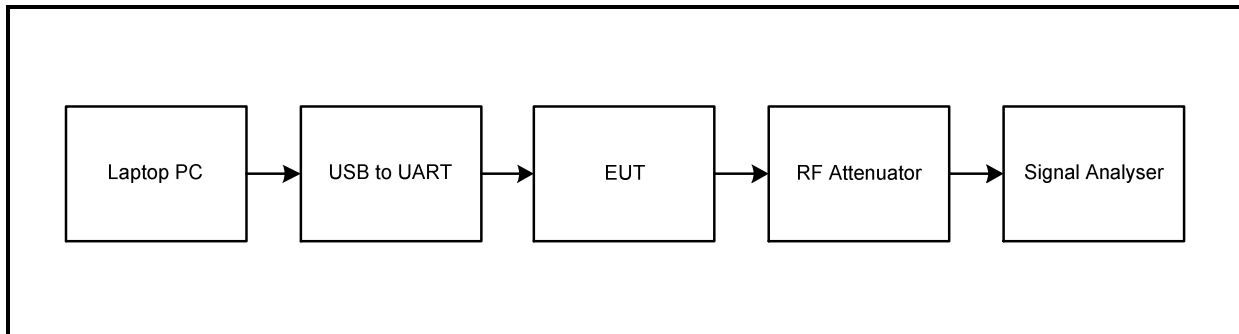

Transmitter Minimum 6 dB Bandwidth (continued)

Results:

Channel	6 dB Bandwidth (kHz)	Limit (kHz)	Margin (kHz)	Result
Bottom	703.300	≥500	203.300	Complied
Middle	703.300	≥500	203.300	Complied
Top	714.900	≥500	214.900	Complied

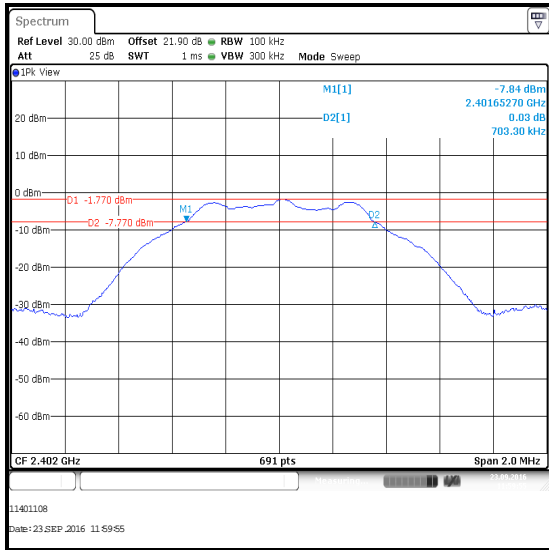

Bottom Channel

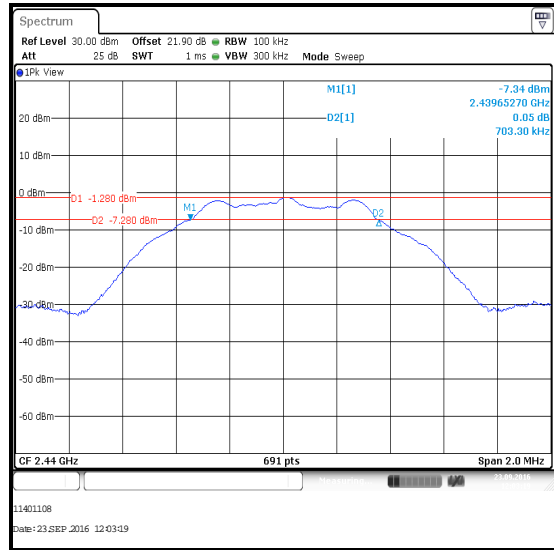

Middle Channel

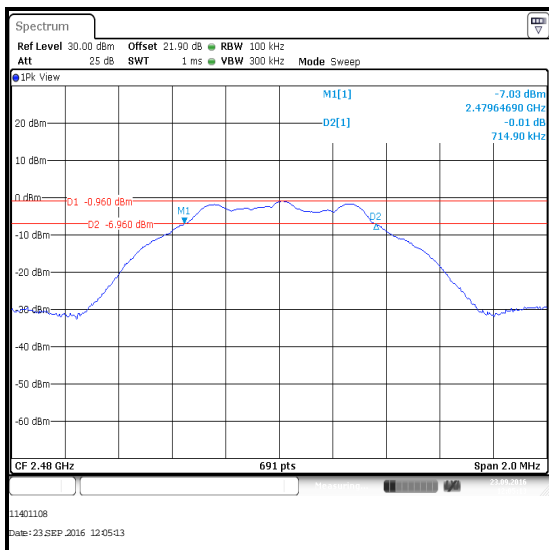

Top Channel

Transmitter Minimum 6 dB Bandwidth (continued)**Test Equipment Used:**

Asset No.	Instrument	Manufacturer	Type No.	Serial No.	Date Calibration Due	Cal. Interval (Months)
M1873	Signal Analyser	Rohde & Schwarz	FSV30	103074	27 Jun 2017	12
G0608	Signal Generator	Rohde & Schwarz	SMIQ 06B	838341/033	29 Apr 2017	12
A2527	Attenuator	AtlanTecRF	AN18W5-20	832828#2	Calibrated before use	-
M1659	Thermohygrometer	JM Handelpunkt	30.5015.13	Not stated	02 Apr 2017	12

5.2.2. Transmitter Maximum Peak Output Power**Test Summary:**

Test Engineer:	Stefan Ho	Test Date:	27 September 2016
Test Sample Serial Number:	#2		

FCC Reference:	Part 15.247(b)(3)
Test Method Used:	FCC KDB 558074 Section 9.1.1

Environmental Conditions:

Temperature (°C):	24
Relative Humidity (%):	50

Note(s):

1. Conducted power tests were performed using a signal analyser in accordance with FCC KDB 558074 Section 9.1.1 with the RBW > *DTS bandwidth* procedure. A resolution bandwidth of 1 MHz was used and the video bandwidth was set to 3 MHz.
2. The signal analyser was connected to the RF port on the EUT using suitable attenuation and RF cable. An RF level offset was entered on the signal analyser to compensate for the loss of the attenuator and RF cable.
3. The conducted power was added to the declared antenna gain to obtain the EIRP.

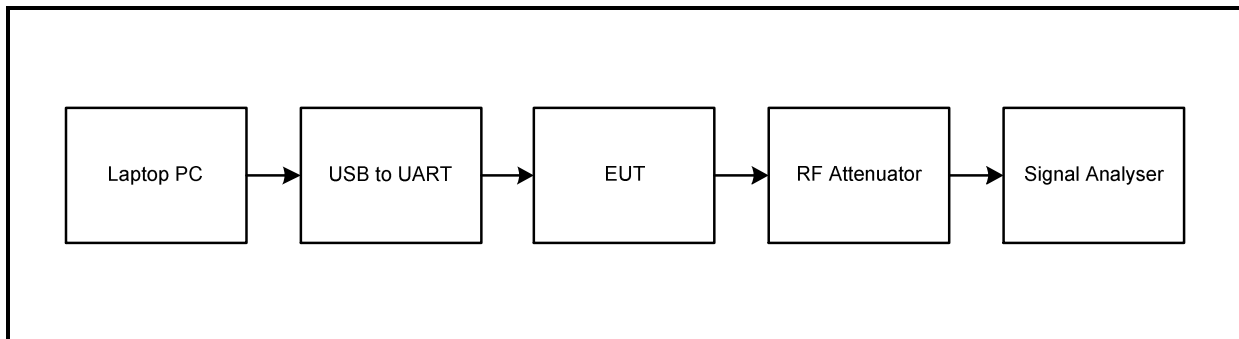
Test setup:

Transmitter Maximum Peak Output Power (continued)**Results:**

Channel	Conducted Peak Power (dBm)	Conducted Peak Power Limit (dBm)	Margin (dB)	Result
Bottom	-1.4	30.0	31.4	Complied
Middle	-0.9	30.0	30.9	Complied
Top	-0.6	30.0	30.6	Complied

Channel	Conducted Peak Power (dBm)	Declared Antenna Gain (dBi)	EIRP (dBm)	De Facto EIRP Limit (dBm)	Margin (dB)	Result
Bottom	-1.4	3.0	1.6	36.0	34.4	Complied
Middle	-0.9	3.0	2.1	36.0	33.9	Complied
Top	-0.6	3.0	2.4	36.0	33.6	Complied

Transmitter Maximum Peak Output Power (continued)

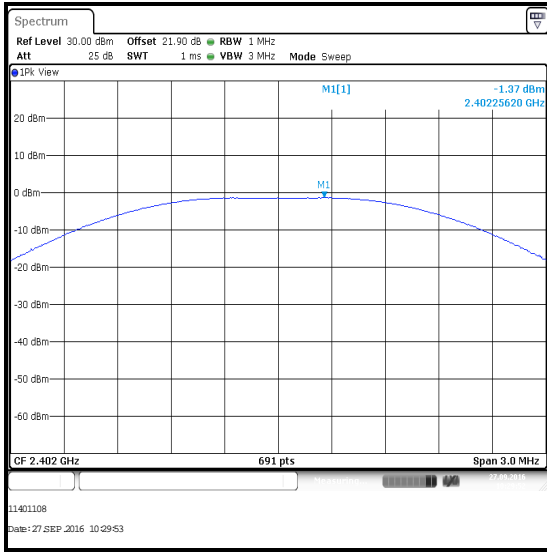

Bottom Channel

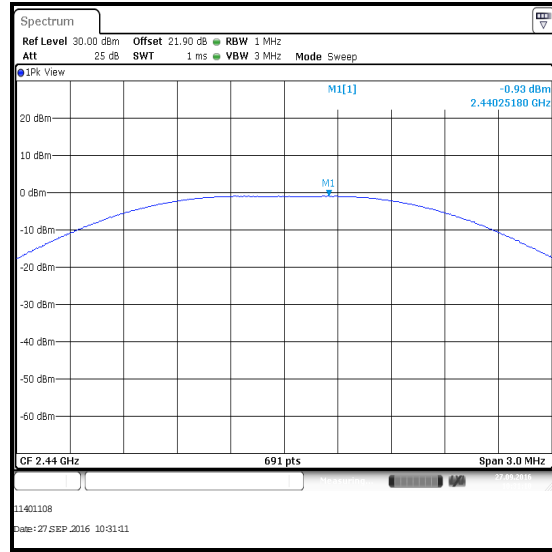

Middle Channel

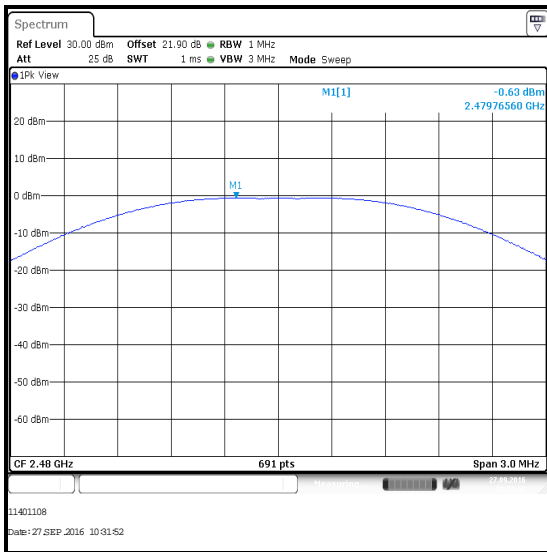

Top Channel

Test Equipment Used:

Asset No.	Instrument	Manufacturer	Type No.	Serial No.	Date Calibration Due	Cal. Interval (Months)
M1873	Signal Analyser	Rohde & Schwarz	FSV30	103074	27 Jun 2017	12
G0608	Signal Generator	Rohde & Schwarz	SMIQ 06B	838341/033	29 Apr 2017	12
A2527	Attenuator	AtlanTecRF	AN18W5-20	832828#2	Calibrated before use	-
M1659	Thermohyrometer	JM Handelspunkt	30.5015.13	Not stated	02 Apr 2017	12

5.2.3. Transmitter Radiated Emissions**Test Summary:**

Test Engineer:	John Ferdinand	Test Date:	09 October 2016
Test Sample Serial Number:	#1		

FCC Reference:	Parts 15.247(d) & 15.209(a)
Test Method Used:	ANSI C63.10 Sections 6.3 and 6.5
Frequency Range	30 MHz to 1000 MHz

Environmental Conditions:

Temperature (°C):	23
Relative Humidity (%):	39

Note(s):

1. The final measured value, for the given emission, in the table below incorporates the calibrated antenna factor and cable loss.
2. The preliminary scans showed similar emission levels below 1 GHz, for each channel of operation. Therefore final radiated emissions measurements were performed with the EUT set to the middle channel only.
3. No spurious emissions were detected above the noise floor of the measuring receiver therefore the highest peak noise floor reading of the measuring receiver was recorded as shown in the table below.
4. Measurements below 1 GHz were performed in a semi-anechoic chamber (Asset Number K0017) at a distance of 3 metres. The EUT was placed at a height of 80 cm above the reference ground plane in the centre of the chamber turntable. Maximum emission levels were determined by height searching the measurement antenna over the range 1 metre to 4 metres.
5. Pre-scans were performed and a marker was placed on the highest measured level. The test receiver resolution bandwidth was set to 100 kHz and video bandwidth 300 kHz. A peak detector was used, sweep time was set to auto and trace mode was Max Hold.

Transmitter Radiated Emissions (continued)

Test setup for radiated measurements:

Semi-anechoic chamber

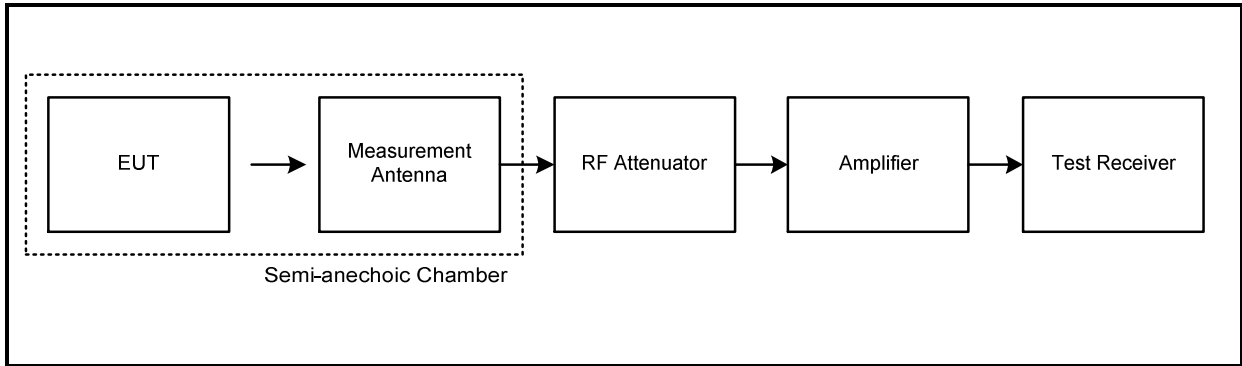

Anechoic chamber

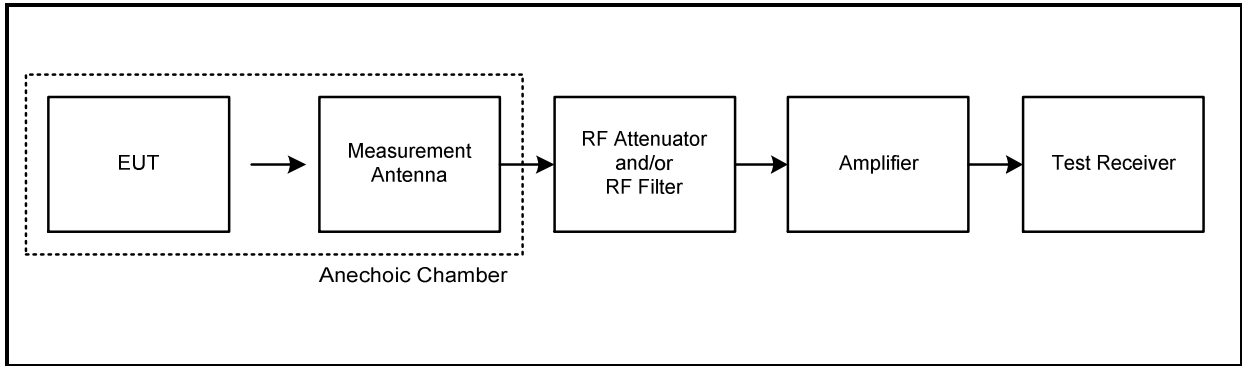

Transmitter Radiated Emissions (continued)

Results: Middle Channel

Frequency (MHz)	Antenna Polarity	Level (dB μ V/m)	Limit (dB μ V/m)	Margin (dB)	Result
928.236	Horizontal	26.4	46.0	19.6	Complied

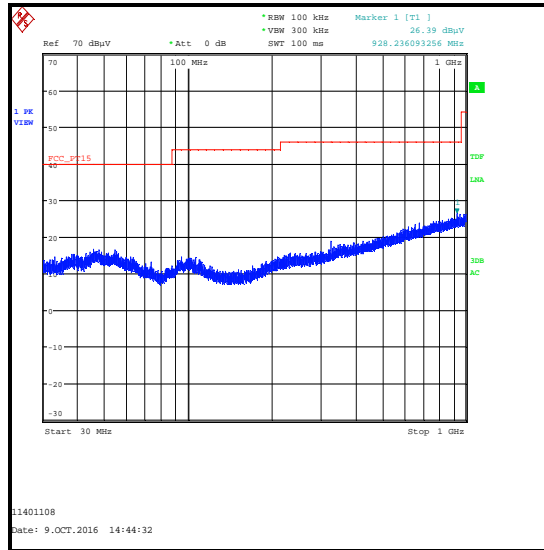

Test Equipment Used:

Asset No.	Instrument	Manufacturer	Type No.	Serial No.	Date Calibration Due	Cal. Interval (Months)
M2003	Thermohygrometer	Testo	608-H1	45046641	22 Apr 2017	12
K0017	3m RSE Chamber	Rainford EMC	N/A	N/A	17 May 2017	12
M1995	Test Receiver	Rohde & Schwarz	ESU40	100428	21 Mar 2017	12
A2888	Antenna	Schwarzbeck	VULB 9163	9163-941	07 Apr 2017	12

Transmitter Radiated Emissions (continued)**Test Summary:**

Test Engineer:	John Ferdinand	Test Dates:	07 October 2016 to 10 October 2016
Test Sample Serial Number:	#1		

FCC Reference:	Parts 15.247(d) & 15.209(a)
Test Method Used:	FCC KDB 558074 Sections 11 & 12 referencing ANSI C63.10 Sections 6.3 and 6.6
Frequency Range	1 GHz to 25 GHz

Environmental Conditions:

Temperature (°C):	21 to 23
Relative Humidity (%):	39 to 43

Note(s):

1. The final measured value, for the given emission, in the table below incorporates the calibrated antenna factor and cable loss.
2. No spurious emissions were detected above the noise floor of the measurement system therefore the highest peak noise floor reading of the measuring receiver was recorded as shown in the table above. The emission shown on the 1 GHz to 3 GHz plot is the EUT fundamental.
3. Measurements above 1 GHz were performed in an anechoic chamber (Asset Number K0017) at a distance of 3 metres. The EUT was placed at a height of 1.5 m above the reference ground plane in the centre of the chamber turntable. Maximum emission levels were determined by height searching the measurement antenna over the range 1 metre to 4 metres.
4. Pre-scans were performed and a marker placed on the highest measured level of the appropriate plot. The test receiver resolution bandwidth was set to 1 MHz and video bandwidth 3 MHz. The sweep time was set to auto.
5. *In accordance with ANSI C63.10 Section 6.6.4.3, Note 1, if the peak measured value complies with the average limit, it is unnecessary to perform an average measurement.

Results: Peak / Middle Channel

Frequency (MHz)	Antenna Polarity	Peak Level (dB μ V/m)	Average Limit (dB μ V/m)	Margin (dB)	Result
17960.000	Horizontal	51.6*	54.0	2.4	Complied

Transmitter Radiated Emissions (continued)

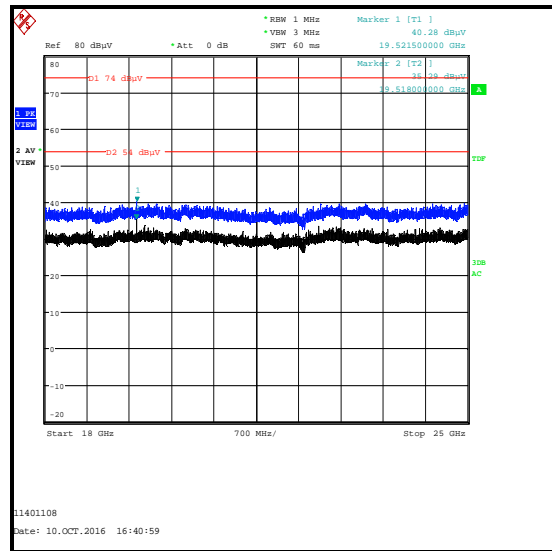
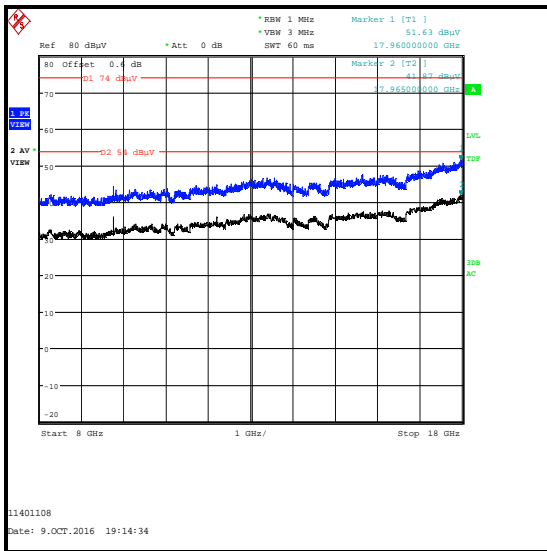
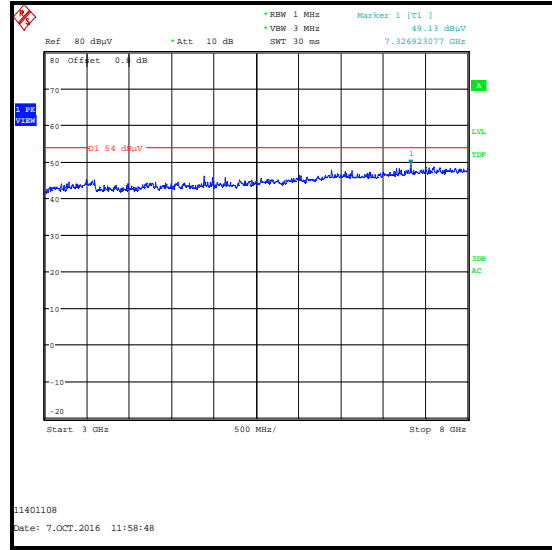
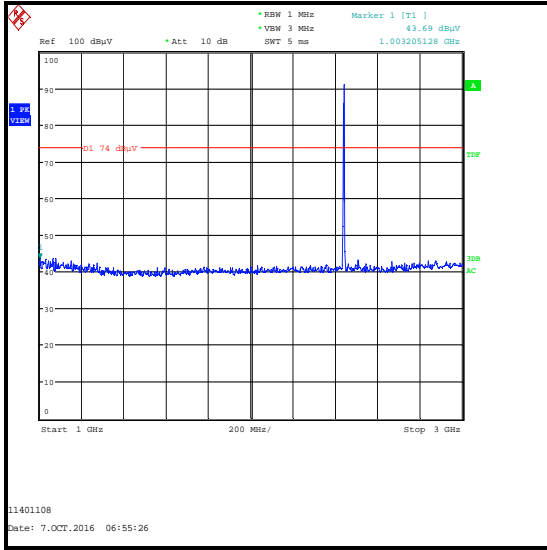

Transmitter Radiated Emissions (continued)**Test Equipment Used:**

Asset No.	Instrument	Manufacturer	Type No.	Serial No.	Date Calibration Due	Cal. Interval (Months)
M2003	Thermohygrometer	Testo	608-H1	45046641	22 Apr 2017	12
K0017	3m RSE Chamber	Rainford EMC	N/A	N/A	17 May 2017	12
M1995	Test Receiver	Rohde & Schwarz	ESU40	100428	21 Mar 2017	12
A2889	Antenna	Schwarzbeck	BBHA 9120 B	BBHA 9120 B 653	07 Apr 2017	12
A2890	Antenna	Schwarzbeck	HWRD 750	014	06 May 2017	12
A2892	Antenna	Schwarzbeck	BBHA 9170	9170-727	07 Apr 2017	12
A2863	Pre-Amplifier	Agilent	8449B	3008A02100	07 Jan 2017	12
A2891	Pre-Amplifier	Schwarzbeck	BBV 9718	9718-306	07 Apr 2017	12
A2893	Pre-Amplifier	Schwarzbeck	BBV 9721	9721-021	07 Apr 2017	12
A2914	High Pass Filter	AtlanTecRF	AFH-03000	2155	19 May 2017	12
A2947	High Pass Filter	AtlanTecRF	AFH-07000	1601900001	01 Jun 2017	12

5.2.4. Transmitter Band Edge Radiated Emissions**Test Summary:**

Test Engineer:	John Ferdinand	Test Date:	07 October 2016
Test Sample Serial Number:	#1		

FCC Reference:	Parts 15.247(d) & 15.209(a)
Test Method Used:	ANSI C63.10 Section 6.10.4, 6.10.5 & KDB 558074 Sections 11, 12.2.4 & 12.2.5.1

Environmental Conditions:

Temperature (°C):	23
Relative Humidity (%):	39

Note(s):

1. The final measured value, for the given emission, in the table below incorporates the calibrated antenna factor and cable loss.
2. The maximum peak conducted output power was previously measured. In accordance with FCC KDB 558074 Section 11.1(a), the lower band edge measurement was performed with a peak detector and the -20 dBc limit applied.
3. As the lower band edge falls within a non-restricted band, only peak measurements are required. In accordance with FCC KDB 558074 Section 11.1, the test method in Section 11.3 was followed: the test receiver resolution bandwidth was set to 100 kHz and video bandwidth 300 kHz. A peak detector was used, sweep time was set to auto and trace mode was Max Hold. The test receiver was left to sweep for a sufficient length of time in order to maximise the carrier level and out-of-band emissions. A marker and corresponding reference level line were placed on the peak of the carrier. As the maximum conducted output power was measured using a peak detector in accordance with FCC KDB 558074 Section 9.1.1, an out-of-band limit line was placed 20 dB (FCC KDB 558074 Section 11.1(a)) below the peak level. A marker was placed on the band edge spot frequencies and a second marker placed on the highest emission level in the adjacent non-restricted band of operation (where a higher level emission was present). Marker frequencies and levels were recorded.
4. As the upper band edge falls within a restricted band both peak and average measurements were recorded by placing a marker at the edge of the band. For peak measurements the test receiver resolution bandwidth was set to 1 MHz and the video bandwidth 3 MHz. A peak detector was used, sweep time was set to auto and trace mode was Max Hold. For average measurements the test receiver resolution bandwidth was set to 1 MHz and the video bandwidth 3 MHz. An RMS detector was used, sweep time was set to auto and trace mode was Max Hold. >300 sweeps were made in order to maximise the carrier level and out-of-band emissions. A marker was placed on the band edge spot frequencies and a second marker placed on the highest emission level in the adjacent restricted band of operation (where a higher level emission was present). Marker frequencies and levels were recorded.
5. There is a restricted band 10 MHz below the lower band edge. The test receiver was set up as follows: the RBW set to 1 MHz, the VBW set to 3 MHz, with the sweep time set to auto couple. Peak and average measurements were performed with their respective detectors. Markers were placed on the highest point on each trace.
6. * -20 dBc limit.
7. **In accordance with ANSI C63.10 Section 6.6.4.3, Note 1, if the peak measured value complies with the average limit, it is unnecessary to perform an average measurement.

Transmitter Band Edge Radiated Emissions (continued)**Results: Lower Band Edge Peak**

Frequency (MHz)	Level (dB μ V/m)	Limit (dB μ V/m)	Margin (dB)	Result
2399.760	44.5	71.0	26.5	Complied
2400.000	43.3	71.0	27.7	Complied

Results: Upper Band Edge / Restricted Band / Peak

Frequency (MHz)	Level (dB μ V/m)	Limit (dB μ V/m)	Margin (dB)	Result
2483.500	57.6	74.0	16.4	Complied
2483.901	57.8	74.0	16.2	Complied

Results: Upper Band Edge / Restricted Band / Average

Frequency (MHz)	Level (dB μ V/m)	Limit (dB μ V/m)	Margin (dB)	Result
2483.5	39.6	54.0	14.4	Complied

Results: 2310 to 2390 Restricted Band

Frequency (MHz)	Peak Level (dB μ V/m)	Average Limit (dB μ V/m)	Margin (dB)	Result
2320.385	41.7**	54.0	12.3	Complied

Transmitter Band Edge Radiated Emissions (continued)

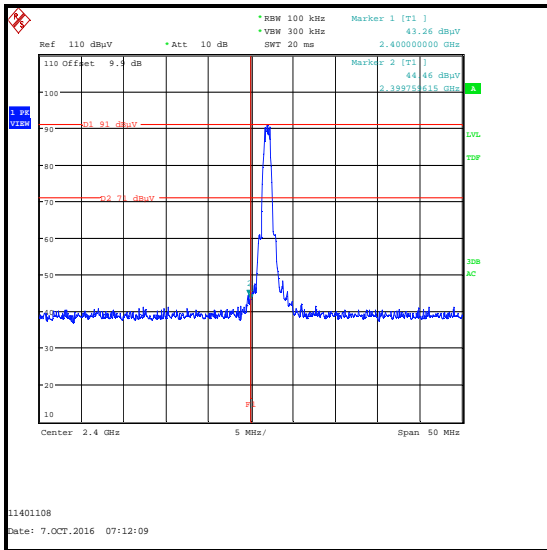

Lower Band Edge Peak Measurement

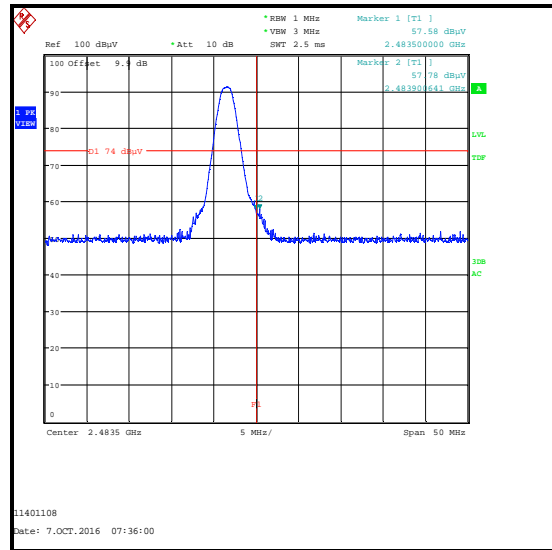

Upper Band Edge Peak Measurement

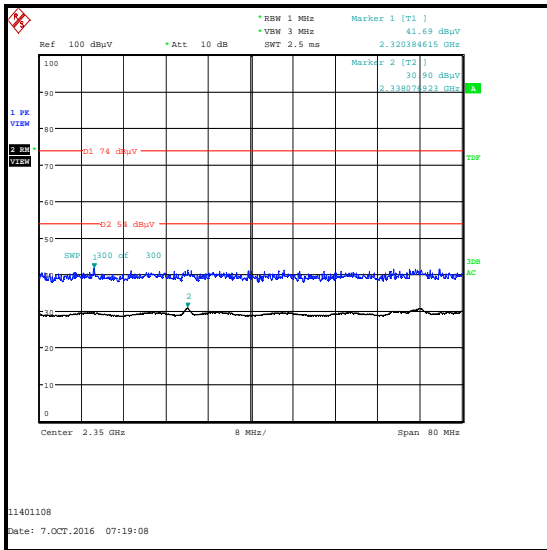

2310 MHz to 2390 MHz Restricted Band Plot

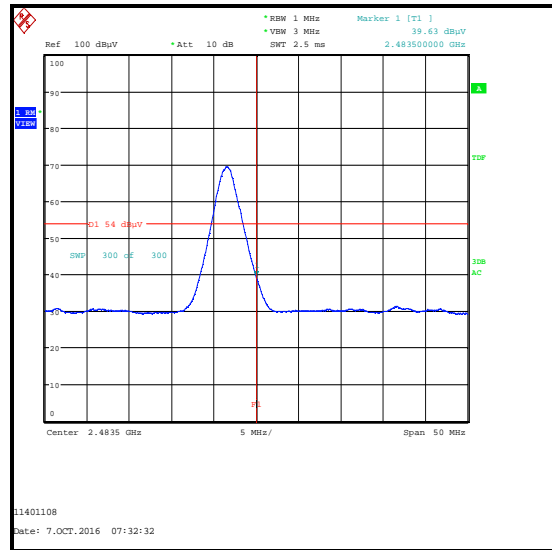

Upper Band Edge Average Measurement

Transmitter Band Edge Radiated Emissions (continued)**Test Equipment Used:**

Asset No.	Instrument	Manufacturer	Type No.	Serial No.	Date Calibration Due	Cal. Interval (Months)
M2003	Thermohygrometer	Testo	608-H1	45046641	22 Apr 2017	12
K0017	3m RSE Chamber	Rainford EMC	N/A	N/A	17 May 2017	12
M1995	Test Receiver	Rohde & Schwarz	ESU40	100428	21 Mar 2017	12
A2889	Antenna	Schwarzbeck	BBHA 9120 B	BBHA 9120 B 653	07 Apr 2017	12
A2863	Pre-Amplifier	Agilent	8449B	3008A02100	07 Jan 2017	12
A2916	Attenuator	AtlanTecRF	AN18W5-10	832827#1	19 May 2017	12

6. Measurement Uncertainty

No measurement or test can ever be perfect and the imperfections give rise to error of measurement in the results. Consequently the result of a measurement is only an approximation to the value measured (the specific quantity subject to measurement) and is only complete when accompanied by a statement of the uncertainty of the approximation.

The expression of uncertainty of a measurement result allows realistic comparison of results with reference values and limits given in specifications and standards.

The uncertainty of the result may need to be taken into account when interpreting the measurement results.

The reported expanded uncertainties below are based on a standard uncertainty multiplied by an appropriate coverage factor such that a confidence level of approximately 95% is maintained. For the purposes of this document "approximately" is interpreted as meaning "effectively" or "for most practical purposes".

Measurement Type	Range	Confidence Level (%)	Calculated Uncertainty
Conducted Maximum Peak Output Power	2.4 GHz to 2.4835 GHz	95%	±1.13 dB
Minimum 6 dB Bandwidth	2.4 GHz to 2.4835 GHz	95%	±4.59 %
Radiated Spurious Emissions	30 MHz to 1 GHz	95%	±5.65 dB
Radiated Spurious Emissions	1 GHz to 25 GHz	95%	±2.94 dB

The methods used to calculate the above uncertainties are in line with those recommended within the various measurement specifications. Where measurement specifications do not include guidelines for the evaluation of measurement uncertainty the published guidance of the appropriate accreditation body is followed.

7. Report Revision History

Version Number	Revision Details		
	Page No(s)	Clause	Details
1.0	-	-	Initial Version

--- END OF REPORT ---