

Appendix A: Plots

Plot 1: 802.11b, Channel 1, Inside arms – Sides facing user’s head

Date/Time: 5/7/2018 3:04:57 PM

Test Laboratory: TUV Rheinland of North America

DUT: Model 447; Serial: M004SW00FCC

Communication System: UID 0, WiFi - 100% Duty Cycle (0); Frequency: 2412 MHz; Duty Cycle: 1:1
Medium parameters used (interpolated): $f = 2412$ MHz; $\sigma = 1.791$ S/m; $\epsilon_r = 37.572$; $\rho = 1000$ kg/m³
Phantom section: Flat Section

Procedure Notes: Operator: Josie; Ambient Temp: 24°C; Liquid Temp: 22.5°C; Comments: ;

DASY5 Configuration:

- Probe: EX3DV4 - SN3957; ConvF(7.75, 7.75, 7.75); Calibrated: 3/26/2018;
- Sensor-Surface: 2mm (Mechanical Surface Detection (Locations From Previous Scan Used)),
Sensor-Surface: 2mm (Mechanical Surface Detection)
- Electronics: DAE4 Sn1419; Calibrated: 3/19/2018
- Phantom: ELI v5.0; Type: QDOVA002AA; Serial: TP: 1254
- Measurement SW: DASY52, Version 52.8 (8); SEMCAD X Version 14.6.10 (7331)

Body/Inside Arms_Low Ch/Area Scan (16x21x1): Measurement grid: dx=12mm, dy=12mm

Info: [Interpolated medium parameters used for SAR evaluation.](#)

Maximum value of SAR (measured) = 0.931 W/kg

Body/Inside Arms_Low Ch/Zoom Scan (7x7x7)/Cube 0: Measurement grid: dx=5mm, dy=5mm,
dz=5mm

Reference Value = 19.33 V/m; Power Drift = -0.10 dB

Peak SAR (extrapolated) = 2.40 W/kg

SAR(1 g) = 0.811 W/kg; SAR(10 g) = 0.327 W/kg (SAR corrected for target medium)

Info: [Interpolated medium parameters used for SAR evaluation.](#)

Maximum value of SAR (measured) = 1.43 W/kg

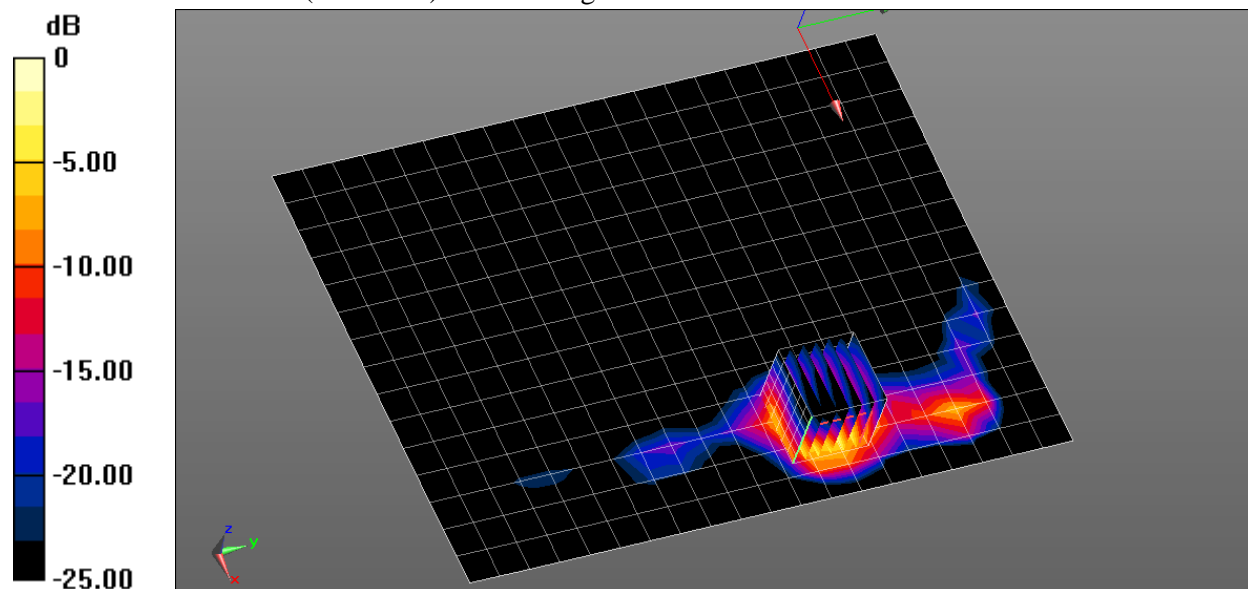

0 dB = 1.43 W/kg = 1.55 dBW/kg

Plot 2: 802.11b, Channel 6, Inside arms – Sides facing user’s head

Date/Time: 5/7/2018 11:43:03 AM

Test Laboratory: TUV Rheinland of North America

DUT: Model 447; Serial: M004SW00FCC

Communication System: UID 0, WiFi - 100% Duty Cycle (0); Frequency: 2437 MHz; Duty Cycle: 1:1
Medium parameters used (interpolated): $f = 2437$ MHz; $\sigma = 1.809$ S/m; $\epsilon_r = 37.536$; $\rho = 1000$ kg/m³
Phantom section: Flat Section

Procedure Notes: Operator: Josie; Ambient Temp: 24°C; Liquid Temp: 22.5°C; Comments: ;

DASY5 Configuration:

- Probe: EX3DV4 - SN3957; ConvF(7.75, 7.75, 7.75); Calibrated: 3/26/2018;
- Sensor-Surface: 2mm (Mechanical Surface Detection (Locations From Previous Scan Used)),
Sensor-Surface: 2mm (Mechanical Surface Detection)
- Electronics: DAE4 Sn1419; Calibrated: 3/19/2018
- Phantom: ELI v5.0; Type: QDOVA002AA; Serial: TP: 1254
- Measurement SW: DASY52, Version 52.8 (8); SEMCAD X Version 14.6.10 (7331)

Body/Inside Arms_Mid Ch/Area Scan (16x21x1): Measurement grid: dx=12mm, dy=12mm

[Info: Interpolated medium parameters used for SAR evaluation.](#)

Maximum value of SAR (measured) = 1.31 W/kg

Body/Inside Arms_Mid Ch/Zoom Scan (7x7x7)/Cube 0: Measurement grid: dx=5mm, dy=5mm, dz=5mm

Reference Value = 0 V/m; Power Drift = 0.00 dB

Peak SAR (extrapolated) = 2.91 W/kg

SAR(1 g) = 0.916 W/kg; SAR(10 g) = 0.336 W/kg (SAR corrected for target medium)

[Info: Interpolated medium parameters used for SAR evaluation.](#)

Maximum value of SAR (measured) = 1.60 W/kg

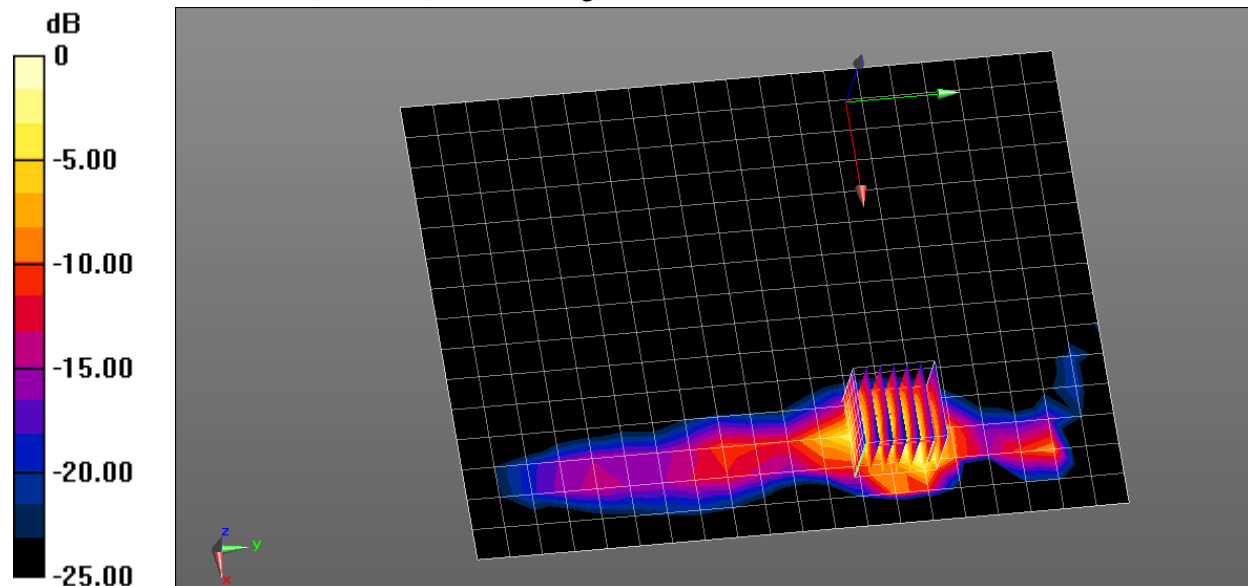

0 dB = 1.31 W/kg = 1.17 dBW/kg

Plot 3: 802.11b, Channel 11, Inside arms – Sides facing user’s head

Date/Time: 5/11/2018 1:42:32 PM

Test Laboratory: TUV Rheinland of North America

DUT: Model 447; Serial: M004SW00FCC

Communication System: UID 0, WiFi - 100% Duty Cycle (0); Frequency: 2462 MHz; Duty Cycle: 1:1
Medium parameters used (interpolated): $f = 2462$ MHz; $\sigma = 1.813$ S/m; $\epsilon_r = 36.994$; $\rho = 1000$ kg/m³
Phantom section: Flat Section

Procedure Notes: Operator: Josie; Ambient Temp: 25°C; Liquid Temp: 23°C; Comments: ;

DASY5 Configuration:

- Probe: EX3DV4 - SN3957; ConvF(7.75, 7.75, 7.75); Calibrated: 3/26/2018;
- Sensor-Surface: 2mm (Mechanical Surface Detection (Locations From Previous Scan Used)),
Sensor-Surface: 2mm (Mechanical Surface Detection)
- Electronics: DAE4 Sn1419; Calibrated: 3/19/2018
- Phantom: ELI v5.0; Type: QDOVA002AA; Serial: TP: 1254
- Measurement SW: DASY52, Version 52.8 (8); SEMCAD X Version 14.6.10 (7331)

Body_5-10-18/Inside Arms_High Ch 2 2/Area Scan (16x21x1): Measurement grid: dx=12mm,
dy=12mm

[Info: Interpolated medium parameters used for SAR evaluation.](#)

Maximum value of SAR (measured) = 1.34 W/kg

Body_5-10-18/Inside Arms_High Ch 2 2/Zoom Scan (7x7x7)/Cube 0: Measurement grid: dx=5mm,
dy=5mm, dz=5mm

Reference Value = 20.63 V/m; Power Drift = -0.03 dB

Peak SAR (extrapolated) = 3.19 W/kg

SAR(1 g) = 1.08 W/kg; SAR(10 g) = 0.410 W/kg (SAR corrected for target medium)

[Info: Interpolated medium parameters used for SAR evaluation.](#)

Maximum value of SAR (measured) = 1.88 W/kg

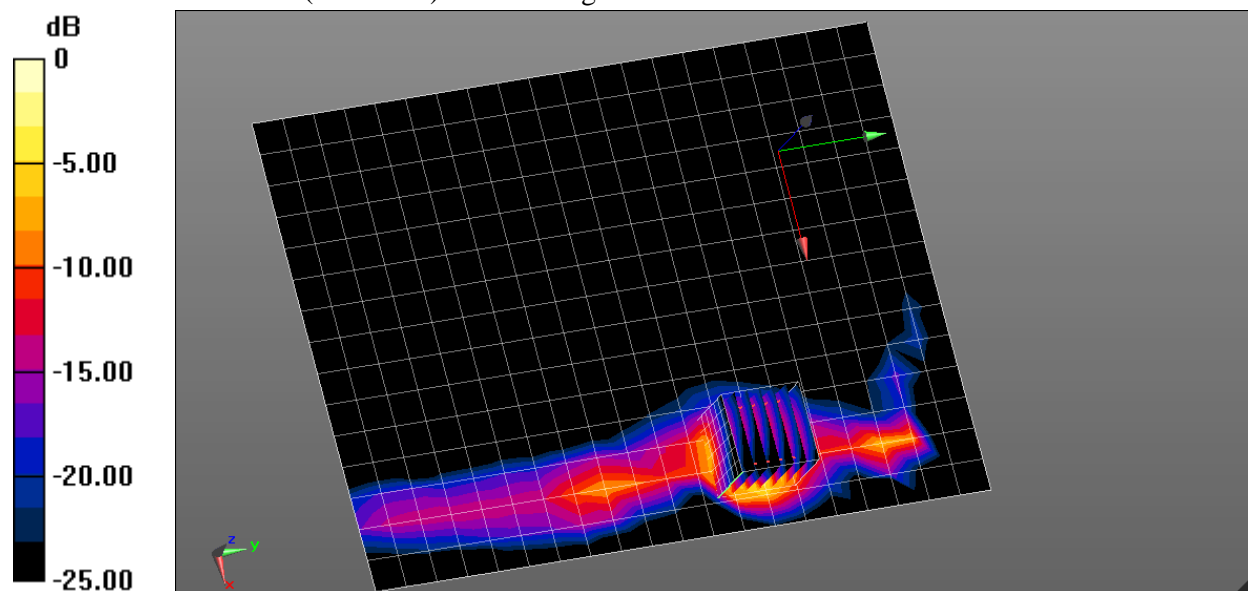

0 dB = 1.88 W/kg = 2.74 dBW/kg

Plot 4: Bluetooth - GFSK, Channel 39, Inside arms – Sides facing user's head

Date/Time: 5/11/2018 10:58:41 AM

Test Laboratory: TUV Rheinland of North America

DUT: Model 447; Serial: M004SW00FCC

Communication System: UID 0, IEEE 802.15.1 Bluetooth (GFSK, DH5) (0); Frequency: 2441 MHz; Duty Cycle: 1:1.30617

Medium parameters used (interpolated): $f = 2441$ MHz; $\sigma = 1.799$ S/m; $\epsilon_r = 37.02$; $\rho = 1000$ kg/m³

Phantom section: Flat Section

Procedure Notes: Operator: Josie; Ambient Temp: 25°C; Liquid Temp: 23°C; Comments: ;

DASY5 Configuration:

- Probe: EX3DV4 - SN3957; ConvF(7.75, 7.75, 7.75); Calibrated: 3/26/2018;
- Sensor-Surface: 2mm (Mechanical Surface Detection (Locations From Previous Scan Used)), Sensor-Surface: 2mm (Mechanical Surface Detection)
- Electronics: DAE4 Sn1419; Calibrated: 3/19/2018
- Phantom: ELI v5.0; Type: QDOVA002AA; Serial: TP: 1254
- Measurement SW: DASY52, Version 52.8 (8); SEMCAD X Version 14.6.10 (7331)

Body_5-10-18/Inside Arms_Mid Ch/Area Scan (16x21x1): Measurement grid: dx=12mm, dy=12mm

[Info: Interpolated medium parameters used for SAR evaluation.](#)

Maximum value of SAR (measured) = 0.00857 W/kg

Body_5-10-18/Inside Arms_Mid Ch/Zoom Scan (8x9x7)/Cube 0: Measurement grid: dx=5mm, dy=5mm, dz=5mm

Reference Value = 1.941 V/m; Power Drift = -0.19 dB

Peak SAR (extrapolated) = 0.115 W/kg

SAR(1 g) = 0.027 W/kg; SAR(10 g) = 0.00631 W/kg (SAR corrected for target medium)

[Info: Interpolated medium parameters used for SAR evaluation.](#)

Maximum value of SAR (measured) = 0.0636 W/kg

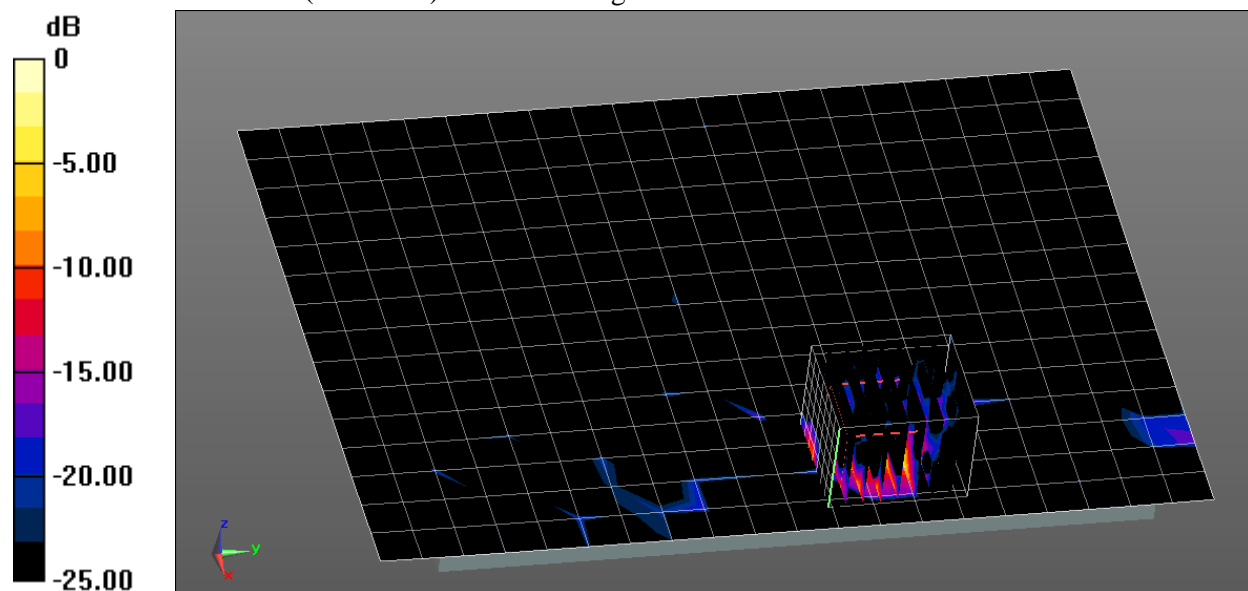

0 dB = 0.0636 W/kg = -11.97 dBW/kg

Plot 5: 802.11b, Channel 6, Outside arms – Sides facing user’s ear

Date/Time: 5/8/2018 5:01:47 PM

Test Laboratory: TUV Rheinland of North America

DUT: Model 447; Serial: M004SW00FCC

Communication System: UID 0, WiFi - 100% Duty Cycle (0); Frequency: 2437 MHz; Duty Cycle: 1:1
Medium parameters used (interpolated): $f = 2437$ MHz; $\sigma = 1.816$ S/m; $\epsilon_r = 37.274$; $\rho = 1000$ kg/m³
Phantom section: Flat Section

Procedure Notes: Operator: Josie; Ambient Temp: 24°C; Liquid Temp: 22.5°C; Comments: ;

DASY5 Configuration:

- Probe: EX3DV4 - SN3957; ConvF(7.75, 7.75, 7.75); Calibrated: 3/26/2018;
- Sensor-Surface: 2mm (Mechanical Surface Detection (Locations From Previous Scan Used)),
Sensor-Surface: 2mm (Mechanical Surface Detection)
- Electronics: DAE4 Sn1419; Calibrated: 3/19/2018
- Phantom: ELI v5.0; Type: QDOVA002AA; Serial: TP: 1254
- Measurement SW: DASY52, Version 52.8 (8); SEMCAD X Version 14.6.10 (7331)

Body 2/Outside Arms_Mid Ch/Area Scan (16x21x1): Measurement grid: dx=12mm, dy=12mm

Info: [Interpolated medium parameters used for SAR evaluation.](#)

Maximum value of SAR (measured) = 0.919 W/kg

Body 2/Outside Arms_Mid Ch/Zoom Scan (7x8x7)/Cube 0: Measurement grid: dx=5mm, dy=5mm, dz=5mm

Reference Value = 10.81 V/m; Power Drift = 0.07 dB

Peak SAR (extrapolated) = 1.32 W/kg

SAR(1 g) = 0.513 W/kg; SAR(10 g) = 0.203 W/kg (SAR corrected for target medium)

Info: [Interpolated medium parameters used for SAR evaluation.](#)

Maximum value of SAR (measured) = 0.879 W/kg

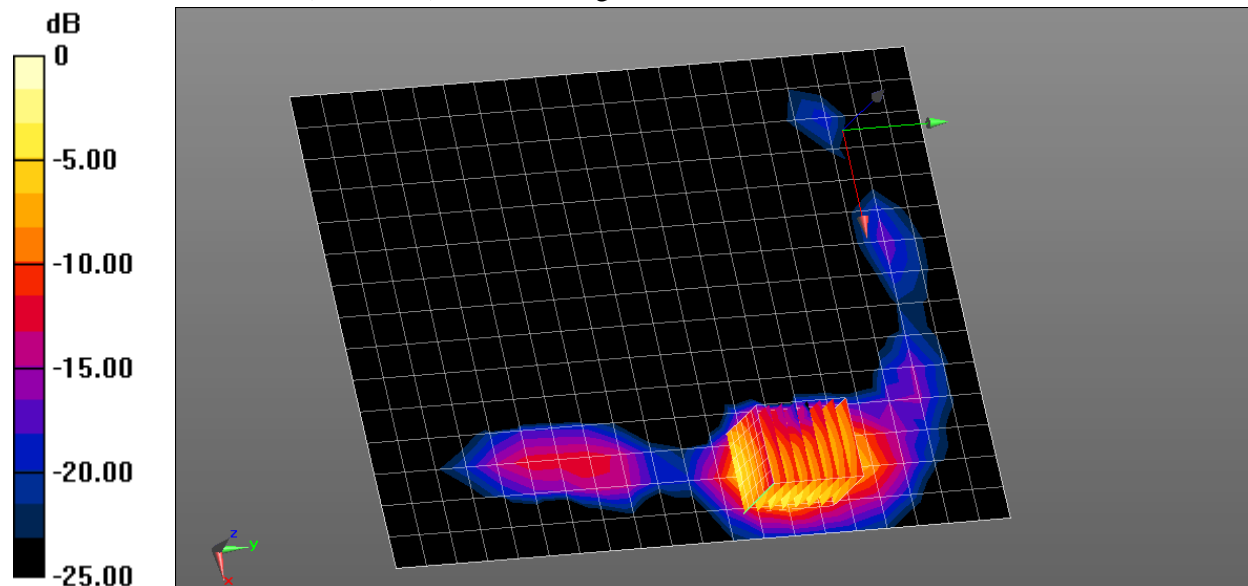

0 dB = 0.919 W/kg = -0.37 dBW/kg

Plot 6: 802.11b, Channel 6, Bottom edge of arms – Edge facing user’s ear

Date/Time: 5/8/2018 2:31:19 PM

Test Laboratory: TUV Rheinland of North America

DUT: Model 447; Serial: M004SW00FCC

Communication System: UID 0, WiFi - 100% Duty Cycle (0); Frequency: 2437 MHz; Duty Cycle: 1:1
Medium parameters used (interpolated): $f = 2437$ MHz; $\sigma = 1.816$ S/m; $\epsilon_r = 37.274$; $\rho = 1000$ kg/m³
Phantom section: Flat Section

Procedure Notes: Operator: Josie; Ambient Temp: 24°C; Liquid Temp: 22.5°C; Comments: ;

DASY5 Configuration:

- Probe: EX3DV4 - SN3957; ConvF(7.75, 7.75, 7.75); Calibrated: 3/26/2018;
- Sensor-Surface: 2mm (Mechanical Surface Detection (Locations From Previous Scan Used)),
Sensor-Surface: 2mm (Mechanical Surface Detection)
- Electronics: DAE4 Sn1419; Calibrated: 3/19/2018
- Phantom: ELI v5.0; Type: QDOVA002AA; Serial: TP: 1254
- Measurement SW: DASY52, Version 52.8 (8); SEMCAD X Version 14.6.10 (7331)

Body 2/Bottom Arms_Mid Ch/Area Scan (16x21x1): Measurement grid: dx=12mm, dy=12mm

[Info: Interpolated medium parameters used for SAR evaluation.](#)

Maximum value of SAR (measured) = 0.0585 W/kg

Body 2/Bottom Arms_Mid Ch/Zoom Scan (7x8x7)/Cube 0: Measurement grid: dx=5mm, dy=5mm, dz=5mm

Reference Value = 4.288 V/m; Power Drift = -0.11 dB

Peak SAR (extrapolated) = 0.0850 W/kg

SAR(1 g) = 0.026 W/kg; SAR(10 g) = 0.0076 W/kg (SAR corrected for target medium)

[Info: Interpolated medium parameters used for SAR evaluation.](#)

Maximum value of SAR (measured) = 0.0525 W/kg

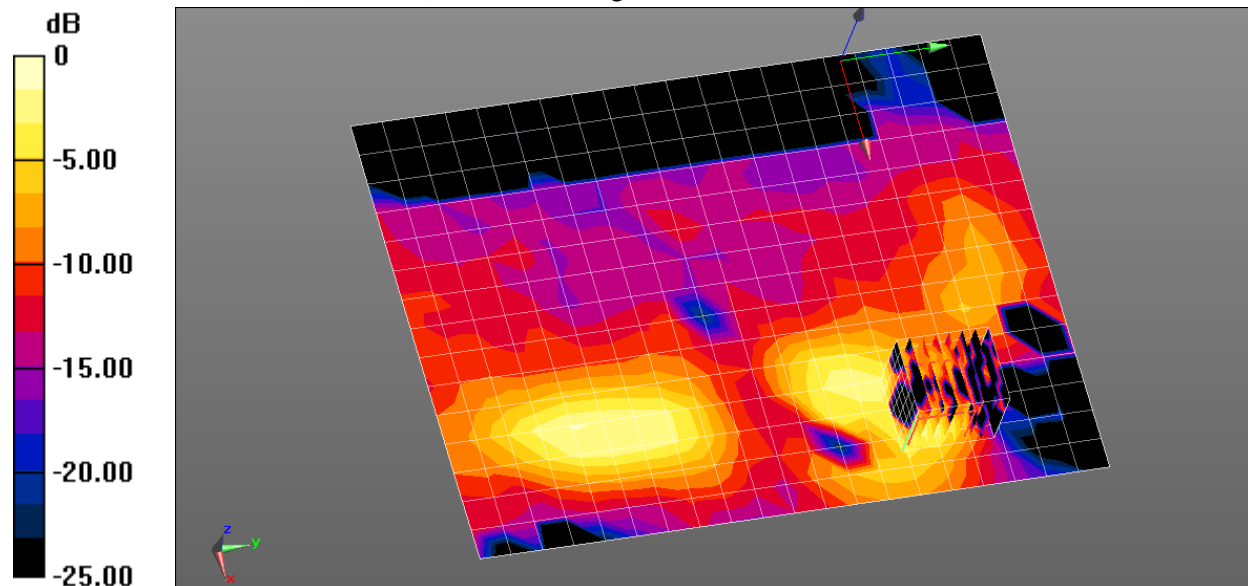

0 dB = 0.0585 W/kg = -12.33 dBW/kg

Plot 7: 2450 MHz System Check – May 7, 2018

Date/Time: 5/7/2018 10:41:28 AM

Test Laboratory: TUV Rheinland of North America

DUT: Dipole 2450 MHz; Serial: 304324-2402102

Communication System: UID 0, CW (0); Frequency: 2450 MHz; Duty Cycle: 1:1
Medium parameters used: $f = 2450$ MHz; $\sigma = 1.818$ S/m; $\epsilon_r = 37.517$; $\rho = 1000$ kg/m³
Phantom section: Flat Section

Procedure Notes: Operator: Josie; Ambient Temp: 24°C; Liquid Temp: 22.5°C; Comments: ;

DASY5 Configuration:

- Probe: EX3DV4 - SN3957; ConvF(7.75, 7.75, 7.75); Calibrated: 3/26/2018;
- Sensor-Surface: 2mm (Mechanical Surface Detection)
- Electronics: DAE4 Sn1419; Calibrated: 3/19/2018
- Phantom: ELI v5.0; Type: QDOVA002AA; Serial: TP: 1254
- Measurement SW: DASY52, Version 52.8 (8); SEMCAD X Version 14.6.10 (7331)

Body/2450 MHz Sys Check/Area Scan (5x5x1): Measurement grid: dx=12mm, dy=12mm
Maximum value of SAR (measured) = 8.51 W/kg

Body/2450 MHz Sys Check/Zoom Scan (7x7x7)/Cube 0: Measurement grid: dx=5mm, dy=5mm,
dz=5mm

Reference Value = 69.30 V/m; Power Drift = -0.10 dB

Peak SAR (extrapolated) = 12.3 W/kg

SAR(1 g) = 5.91 W/kg; SAR(10 g) = 2.7 W/kg (SAR corrected for target medium)

Maximum value of SAR (measured) = 9.10 W/kg

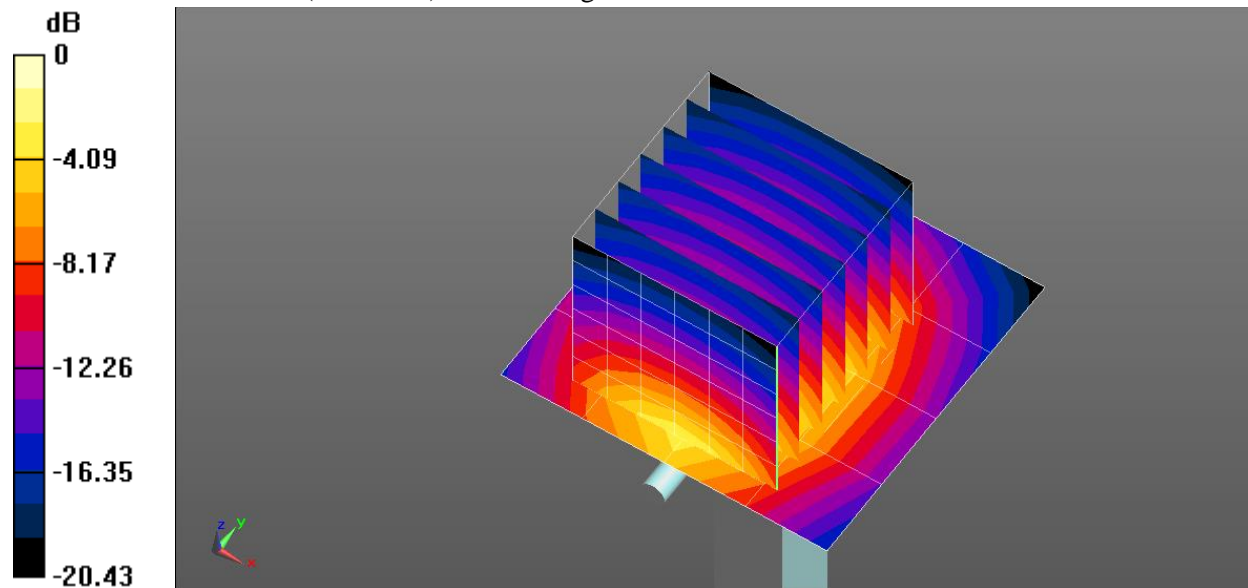

0 dB = 8.51 W/kg = 9.30 dBW/kg

Plot 8: 2450 MHz System Check – May 8, 2018

Date/Time: 5/7/2018 10:41:28 AM

Test Laboratory: TUV Rheinland of North America

DUT: Dipole 2450 MHz; Serial: 304324-2402102

Communication System: UID 0, CW (0); Frequency: 2450 MHz; Duty Cycle: 1:1
Medium parameters used: $f = 2450$ MHz; $\sigma = 1.818$ S/m; $\epsilon_r = 37.517$; $\rho = 1000$ kg/m³
Phantom section: Flat Section

Procedure Notes: Operator: Josie; Ambient Temp: 24°C; Liquid Temp: 22.5°C; Comments: ;

DASY5 Configuration:

- Probe: EX3DV4 - SN3957; ConvF(7.75, 7.75, 7.75); Calibrated: 3/26/2018;
- Sensor-Surface: 2mm (Mechanical Surface Detection)
- Electronics: DAE4 Sn1419; Calibrated: 3/19/2018
- Phantom: ELI v5.0; Type: QDOVA002AA; Serial: TP: 1254
- Measurement SW: DASY52, Version 52.8 (8); SEMCAD X Version 14.6.10 (7331)

Body/2450 MHz Sys Check/Area Scan (5x5x1): Measurement grid: dx=12mm, dy=12mm
Maximum value of SAR (measured) = 8.51 W/kg

Body/2450 MHz Sys Check/Zoom Scan (7x7x7)/Cube 0: Measurement grid: dx=5mm, dy=5mm,
dz=5mm

Reference Value = 69.30 V/m; Power Drift = -0.10 dB

Peak SAR (extrapolated) = 12.3 W/kg

SAR(1 g) = 5.91 W/kg; SAR(10 g) = 2.7 W/kg (SAR corrected for target medium)

Maximum value of SAR (measured) = 9.10 W/kg

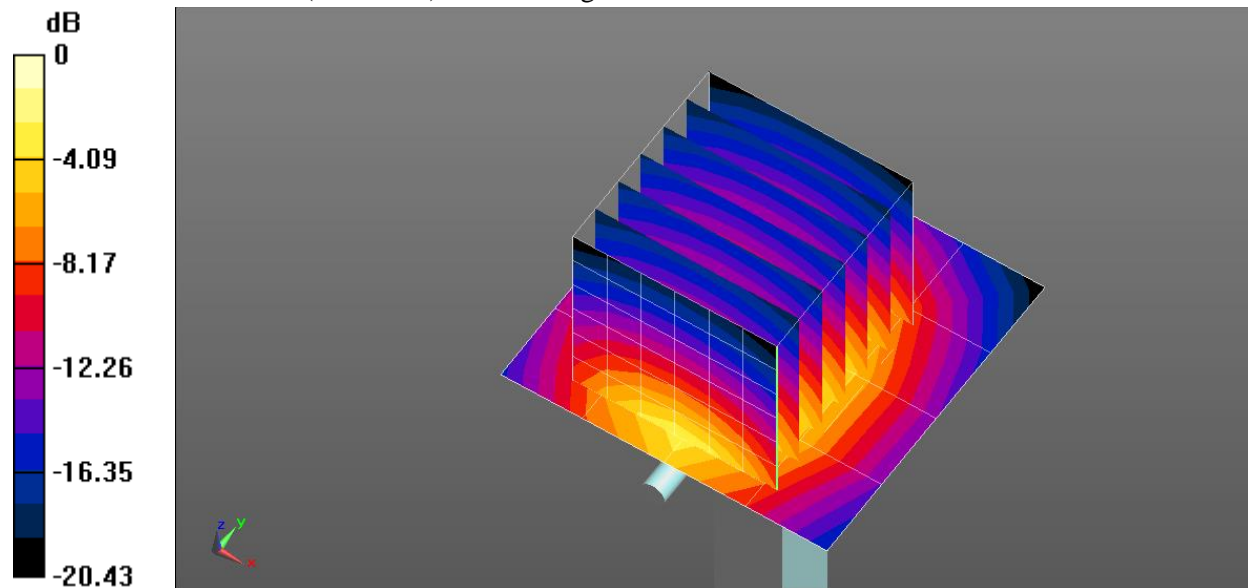

0 dB = 8.51 W/kg = 9.30 dBW/kg

Plot 9: 2450 MHz System Check – May 10, 2018

Date/Time: 5/10/2018 2:48:33 PM

Test Laboratory: TUV Rheinland of North America

DUT: Dipole 2450 MHz; Serial: 304324-2402102

Communication System: UID 0, CW (0); Frequency: 2450 MHz; Duty Cycle: 1:1
Medium parameters used: $f = 2450$ MHz; $\sigma = 1.805$ S/m; $\epsilon_r = 37.009$; $\rho = 1000$ kg/m³
Phantom section: Flat Section

Procedure Notes: Operator: Josie; Ambient Temp: 25°C; Liquid Temp: 23°C; Comments: ;

DASY5 Configuration:

- Probe: EX3DV4 - SN3957; ConvF(7.75, 7.75, 7.75); Calibrated: 3/26/2018;
- Sensor-Surface: 2mm (Mechanical Surface Detection)
- Electronics: DAE4 Sn1419; Calibrated: 3/19/2018
- Phantom: ELI v5.0; Type: QDOVA002AA; Serial: TP: 1254
- Measurement SW: DASY52, Version 52.8 (8); SEMCAD X Version 14.6.10 (7331)

Body/2450 MHz Sys Check/Area Scan (5x5x1): Measurement grid: dx=12mm, dy=12mm
Maximum value of SAR (measured) = 7.85 W/kg

Body/2450 MHz Sys Check/Zoom Scan (7x7x7)/Cube 0: Measurement grid: dx=5mm, dy=5mm, dz=5mm

Reference Value = 66.65 V/m; Power Drift = 0.01 dB

Peak SAR (extrapolated) = 12.0 W/kg

SAR(1 g) = 5.73 W/kg; SAR(10 g) = 2.62 W/kg (SAR corrected for target medium)

Maximum value of SAR (measured) = 8.85 W/kg

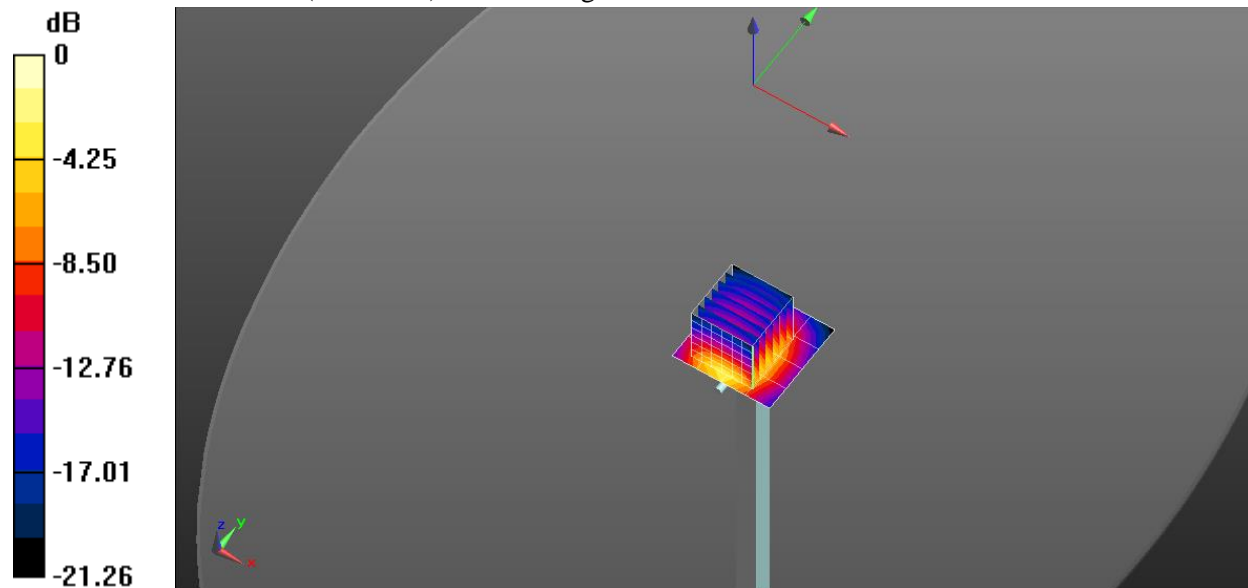

0 dB = 7.85 W/kg = 8.95 dBW/kg