

# FCC & ISED Test Report

## (Part 24&27&RSS130&133&139)

Product Name : LE910C1-NA  
Model No : LE910C1-NA  
FCC ID : RI7LE910C1NA  
IC ID : 5131A-LE910C1NA

Applicant : Telit Communications S.p.A.

Address : Viale Stazione di Prosecco, 5/B, 34010 Sgonico, Trieste, Italy

Date of Receipt : 2016/12/29  
Issued Date : 2017/02/23  
Report No. : 1710065R-HPUSP37V00  
Report Version : V1.0



The test results relate only to the samples tested.

The test results shown in the test report are traceable to the national/international standard through the calibration of the equipment and evaluated measurement uncertainty herein.

This report must not be used to claim product endorsement by TAF or any agency of the government.

The test report shall not be reproduced without the written approval of DEKRA Testing and Certification Co., Ltd.

# Test Report

Issued Date : 2017/02/23

Report No.: 1710065R-HPUSP37V00



Product Name : LE920A4-NA  
Applicant : Telit Communications S.p.A.  
Address : Viale Stazione di Prosecco, 5/B, 34010 Sgonico, Trieste, Italy  
Manufacturer : Telit Wireless Solutions Ltd.  
Trade Name :   
Model No. : LE910C1-NA  
EUT Rated Voltage : DC 3.8V  
EUT Test Voltage : DC 3.8V (Power By Adapter AC 120V/60Hz)  
Measurement Standard : FCC CFR Title 47 Part 2 24 27  
RSS GEN Issue 4, RSS-130 Issue 1  
RSS-133 Issue 6, RSS-139 Issue 3  
Measurement Reference : TIA/EIA 603-D  
Test Result : Complied

Documented By : Elephant Chen  
( Adm. Assistant / Elephant Chen )

Tested By : Vorana Chen  
( Senior Engineer / Vorana Chen )

Approved By :   
( Director / Vincent Lin )

## TABLE OF CONTENTS

Description	Page
1. GENERAL INFORMATION .....	4
1.1. EUT Description .....	4
1.2. Antenna List.....	4
1.3. Operational Description.....	5
1.4. Configuration of tested System .....	6
1.5. EUT Setup Procedures .....	6
1.6. Test Facility .....	7
1.7. Type of Emission .....	8
1.8. Voltages and DC currents .....	9
2. Technical Test .....	9
2.1. Summary of test result .....	10
2.2. List of test Equipment.....	11
2.3. Measurement Uncertainty.....	11
3. Conducted Output Power Measurement .....	12
3.1. Test Specification .....	12
3.2. Test Setup .....	12
3.3. Limits.....	12
3.4. Test Procedure .....	12
3.5. Test Result of Maximum Power Output.....	13
4. Occupied Bandwidth .....	26
4.1. Test Specification .....	26
4.2. Test Setup .....	26
4.3. Test Procedure .....	26
4.4. Test Result of Occupied Bandwidth .....	27
5. Spurious Emission At Antenna Terminals (+/-1MHz).....	40
5.1. Test Specification .....	40
5.2. Setup.....	40
5.3. Limits.....	40
5.4. Test Procedure .....	40
5.5. Test Result of Spurious Emission At Antenna Terminals (+/-1MHz).....	41
6. Spurious Emission .....	83
6.1. Test Specification .....	83
6.2. Test Setup .....	83
6.3. Limits.....	84
6.4. Test Procedure .....	84
6.5. Test Result of Spurious Emission .....	85
7. Frequency Stability Under Temperature & Voltage Variations.....	160
7.1. Test Specification .....	160
7.2. Test Setup .....	160
7.3. Limits.....	160
7.4. Test Procedure .....	160
7.5. Test Result of Frequency Stability Under Temperature Variations.....	161
8. Peak to Average Ratio .....	182
8.1 Test Specification .....	182
8.2 Test Setup.....	182
8.3 Limits.....	182
8.4 Test Procedure .....	182
8.5 Test Result of Spurious Emission .....	183
Attachment 1: EUT Test Photographs	
Attachment 2: EUT Detailed Photographs	

## 1. GENERAL INFORMATION

### 1.1. EUT Description

Product Name	LE910C1-NA
Model No.	LE910C1-NA
Trade Name	
IMEI No.	35986507
FCC ID	RI7LE910C1NA
IC ID	5131A-LE920A4N4
Modulation	LTE Band 2 : QPSK/16-QAM
	LTE Band 4 : QPSK/16-QAM
	LTE Band 12 : QPSK/16-QAM
TX Frequency	LTE Band 2: 1850MHz ~1910MHz
	LTE Band 4 : 1710MHz~1755MHz
	LTE Band 12 : 699MHz~716MHz
Rx Frequency	LTE Band 2: 1930MHz ~1990MHz
	LTE Band 4: 2110MHz ~2155MHz
	LTE Band 12 : 729MHz ~746MHz
Bandwidth	LTE Band 2: 1.4MHz/3MHz/5MHz/10MHz
	LTE Band 4: 1.4MHz/3MHz/5MHz/10MHz
	LTE Band 12 : 1.4MHz/3MHz/5MHz/10MHz
HW Version	1.00
SW Version	25.00.211
Antenna Type	Dipole

### 1.2. Antenna List

No.	Manufacturer	Part No.	Peak Gain
1	Larid Technologies	DBA6927	0.99 dBi for 699-960MHz 2.37 dBi for 1710-2170MHz 2.81 dBi for 2400-2700MHz

### 1.3. Operational Description

The information contained within this report is intended to show verification of compliance of the 700/1700/1900MHz to the requirements of FCC 47 CFR Part 2, 24 and 27 & RSS GEN, RSS 130, RSS 133, RSS 139.

The EUT provide all functions described as above. The EUT is tested with maximum rated TX power via the Base Station simulator.

DEKRA has verified the construction and function in typical operation. All the test modes were carried out with the EUT in normal operation, which was shown in this test report and defined

as:

Test Mode:	LTE Band 2 (1.4M)-QPSK/16QAM
	LTE Band 2 (3M)-QPSK/16QAM
	LTE Band 2 (5M)-QPSK/16QAM
	LTE Band 2 (10M)-QPSK
	LTE Band 4 (1.4M)-QPSK/16QAM
	LTE Band 4 (3M)-QPSK/16QAM
	LTE Band 4 (5M)-QPSK/16QAM
	LTE Band 4 (10M)-QPSK
	LTE Band 12 (1.4M)-QPSK/16QAM
	LTE Band 12 (3M)-QPSK/16QAM
	LTE Band 12 (5M)-QPSK/16QAM
	LTE Band 12 (10M)-QPSK

Note :

1. The maximum power levels are chosen in the LTE Band 2/4/12, only these modes were used for all tests.
2. The module does not support 10M-16QAM, 15M-QPSK/16QAM, 20M-QPSK/16QAM.

## 1.4. Configuration of tested System

### (a) Configuration of Radiated measurement

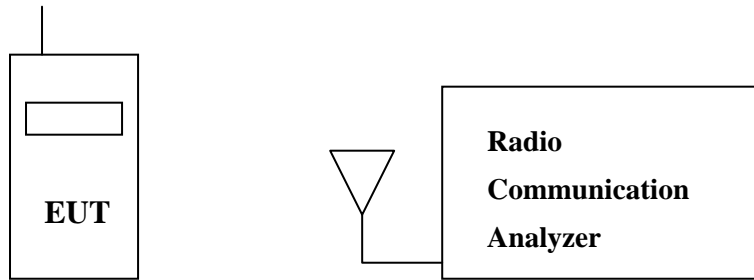

### (b) Configuration of Conducted measurement

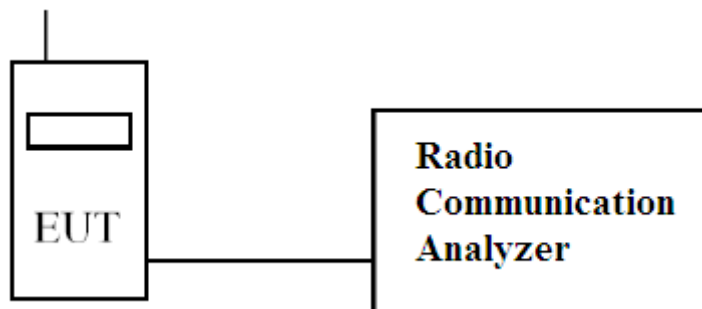

## 1.5. EUT Setup Procedures

- (1) Setup the EUT and simulators as shown on 1.3
- (2) Turn on the power of all equipments.
- (3) The EUT was set to communicate with MT8820C.
- (4) Repeat the above procedure (3).

## 1.6. Test Facility

Ambient conditions in the laboratory:

Items	Required (IEC 68-1)	Actual
Temperature (°C)	15-35	22
Humidity (%RH)	25-75	51
Barometric pressure (mbar)	860-1060	988

The related certificate for our laboratories about the test site and management system can be downloaded from DEKRA Testing and Certification Co., Ltd. Web Site:

<http://www.dekra.com.tw/english/about/certificates.aspx?bval=5>

The address and introduction of DEKRA Testing and Certification Co., Ltd. laboratories can be founded in our Web site: [http://www.dekra.com.tw/index\\_en.aspx](http://www.dekra.com.tw/index_en.aspx)

Site Description: File on

Federal Communications Commission  
FCC Engineering Laboratory  
7435 Oakland Mills Road  
Columbia, MD 21046  
FCC Registration Number :92195

Site Name: DEKRA Testing and Certification Co., Ltd

Site Address: No.5-22, Ruishukeng, Linkou Dist., New Taipei City 24451,  
Taiwan, R.O.C.

TEL : 886-2-8601-3788 / FAX : 886-2-8601-3789

E-Mail : [info.tw@dekra.com](mailto:info.tw@dekra.com)

FCC Accreditation Number: TW1014

### 1.7. Type of Emission

Band	Bandwidth (MHz)	Modulation	
		QPSK	16QAM
2	1.4	1M10G7D	1M10W7D
2	3	2M74G7D	2M72W7D
2	5	4M50G7D	4M49W7D
2	10	9M04G7D	--
4	1.4	1M10G7D	1M10W7D
4	3	2M73G7D	2M72W7D
4	5	4M51G7D	4M49W7D
4	10	9M04G7D	--
12	1.4	1M10G7D	1M09W7D
12	3	2M73G7D	2M72W7D
12	5	4M50G7D	4M48W7D
12	10	8M97G7D	--



## 1.8. Voltages and DC currents

LTE Band 2 (1.4M)	EUT Transmitting (in maximum power) : AC voltage : 120V , AC current : 0.058A
	EUT Standby : AC voltage : 120V , AC current : 0.010A
LTE Band 2 (3M)	EUT Transmitting (in maximum power) : AC voltage : 120V , AC current : 0.058A
	EUT Standby : AC voltage : 120V , AC current : 0.010A
LTE Band 2 (5M)	EUT Transmitting (in maximum power) : AC voltage : 120V , AC current : 0.058A
	EUT Standby : AC voltage : 120V , AC current : 0.010A
LTE Band 2 (10M)	EUT Transmitting (in maximum power) : AC voltage : 120V , AC current : 0.058A
	EUT Standby : AC voltage : 120V , AC current : 0.010A
LTE Band 4 (1.4M)	EUT Transmitting (in maximum power) : AC voltage : 120V , AC current : 0.060A
	EUT Standby : AC voltage : 120V , AC current : 0.010A
LTE Band 4 (3M)	EUT Transmitting (in maximum power) : AC voltage : 120V , AC current : 0.061A
	EUT Standby : AC voltage : 120V , AC current : 0.010A
LTE Band 4 (5M)	EUT Transmitting (in maximum power) : AC voltage : 120V , AC current : 0.061A
	EUT Standby : AC voltage : 120V , AC current : 0.010A
LTE Band 4 (10M)	EUT Transmitting (in maximum power) : AC voltage : 120V , AC current : 0.062A
	EUT Standby : AC voltage : 120V , AC current : 0.010A
LTE Band 12 (1.4M)	EUT Transmitting (in maximum power) : AC voltage : 120V , AC current : 0.052A
	EUT Standby : AC voltage : 120V , AC current : 0.010A
LTE Band 12 (3M)	EUT Transmitting (in maximum power) : AC voltage : 120V , AC current : 0.052A
	EUT Standby : AC voltage : 120V , AC current : 0.010A
LTE Band 12 (5M)	EUT Transmitting (in maximum power) : AC voltage : 120V , AC current : 0.053A
	EUT Standby : AC voltage : 120V , AC current : 0.010A
LTE Band 12 (10M)	EUT Transmitting (in maximum power) : AC voltage : 120V , AC current : 0.054A
	EUT Standby : AC voltage : 120V , AC current : 0.010A

## 2. Technical Test

### 2.1. Summary of test result

FCC Standard	IC Standard	Test Item	Result	Note
2.1046	RSS GEN	Conducted Output Power	Pass	
24.232(c)	RSS 130			
27.5	RSS 133/RSS 139			
2.1049	RSS GEN	Occupied Bandwidth	Pass	
24.238(b)	RSS 130			
27.53 (g)	RSS 133/RSS 139			
2.1051	RSS GEN	Spurious Emission at Antenna Terminals	Pass	
24.238(a)	RSS 130			
27.53 (g)	RSS 133/RSS 139			
2.1051	RSS GEN	Conducted Emission	Pass	
24.238(a)	RSS 130			
27.53 (g)	RSS 133/RSS 139			
2.1053	RSS GEN	Field Strength of Spurious Radiation	Pass	
24.238(a)	RSS 130			
27.53 (g)	RSS 133/RSS 139			
2.1055	RSS GEN	Frequency Stability for Temperature & Voltage	Pass	
24.235	RSS 130			
27.54	RSS 133/RSS 139			
24.232(d)	RSS 130	Peak to Average Ratio	Pass	
27.50(a)	RSS 133/RSS 139			

## 2.2. List of test Equipment

Conducted /CTR

Instrument	Manufacturer	Type No.	Serial No	Cal. Date
Spectrum Analyzer	Agilent	N9010A	MY52220597	2016/02/18
Directional coupler	Agilent	87300C	MY44300353	2016/11/04
Directional coupler	Agilent	778D-012	50550	2016/11/08
Standard Temperature & Humidity Chamber	WIT	TH-1S-B	EQ-201-00146	2016/11/28
DC power supply	Agilent	E3610A	MY40009845	2016/07/14
Communication Tester	Agilent	8820C	6201465467	2016/06/21

Radiated / Site3

Instrument	Manufacturer	Type No.	Serial No	Cal. Date
Bilog Antenna	Schaffner Chase	CBL6112B	2707	2016/06/11
Horn Antenna	R&S	9120D	556	2017/01/25
Pre-Amplifier	Agilent	87405C	MY47010653	2016/08/11
Spectrum Analyzer	Agilent	N9010A	MY52220597	2016/02/18
DC power supply	Agilent	E3610A	MY40009845	2016/07/14
Communication Tester	Agilent	8820C	6201465467	2016/06/21

## 2.3. Measurement Uncertainty

### Conducted Emission

The measurement uncertainty of confidence of 95% is evaluated as  $\pm 1.52$  dB

### Radiated Emission (Below 1GHz)

The measurement uncertainty of confidence of 95% is evaluated as  $\pm 3.44$  dB .

### Radiated Emission (Above 1GHz)

The measurement uncertainty of confidence of 95% is evaluated as  $\pm 4.08$  dB

### 3. Conducted Output Power Measurement

#### 3.1. Test Specification

According to FCC Part 2.1046, 24.232, 27.50  
RSS GEN, RSS 130, RSS 133, RSS 139

#### 3.2. Test Setup

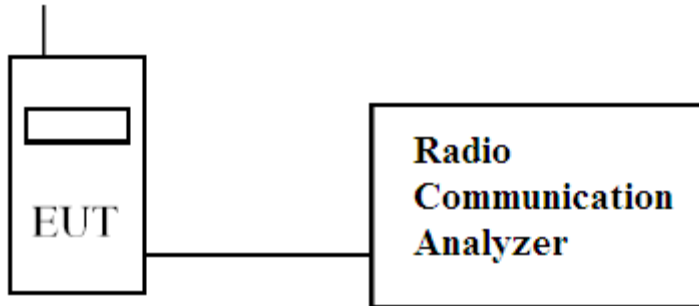

#### 3.3. Limits

Band	Limit
LTE Band 2/1900	<2W
LTE Band 4/1700	<1W
LTE Band 12/700	<3W

#### 3.4. Test Procedure

The EUT is tested with maximum rated TX power via the Base Station simulator, and the output power was measured at the antenna terminals of the EUT.

**3.5. Test Result of Maximum Power Output**

Band	Channel	Modulation	RB No.	RB Offset	MPR	Max Power (dBm)	Max Power (W)
Band 2 (1900MHz)/1.4MHz	1850.7MHz CH18607	QPSK	1	#0	0	23.40	0.219
			1	#Mid	0	23.48	0.223
			1	#Max	0	23.44	0.221
			50%	#0	1	23.38	0.218
			50%	#Mid	1	<b>23.63</b>	<b>0.231</b>
			50%	#Max	1	23.41	0.219
			100%	--	1	22.29	0.169
		16QAM	1	#0	1	22.35	0.172
			1	#Mid	1	22.47	0.177
			1	#Max	1	22.38	0.173
			50%	#0	2	22.03	0.160
			50%	#Mid	2	22.55	0.180
			50%	#Max	2	<b>22.58</b>	<b>0.181</b>
			100%	--	2	21.42	0.139
	1880MHz CH18900	QPSK	1	#0	0	23.03	0.201
			1	#Mid	0	23.03	0.201
			1	#Max	0	23.06	0.202
			50%	#0	1	23.01	0.200
			50%	#Mid	1	<b>23.15</b>	<b>0.207</b>
			50%	#Max	1	23.12	0.205
			100%	--	1	22.17	0.165
		16QAM	1	#0	1	21.76	0.150
			1	#Mid	1	21.60	0.145
			1	#Max	1	21.77	0.150
			50%	#0	2	22.10	0.162
			50%	#Mid	2	<b>22.24</b>	<b>0.167</b>
			50%	#Max	2	21.92	0.156
			100%	--	2	20.84	0.121
	1909.3MHz CH19193	QPSK	1	#0	0	23.12	0.205
			1	#Mid	0	<b>23.17</b>	<b>0.207</b>
1			#Max	0	23.09	0.204	
50%			#0	1	23.08	0.203	
50%			#Mid	1	23.08	0.203	
50%			#Max	1	23.02	0.200	
100%			--	1	22.16	0.164	
16QAM		1	#0	1	22.39	0.173	
		1	#Mid	1	22.39	0.173	
		1	#Max	1	22.24	0.167	
		50%	#0	2	22.36	0.172	
		50%	#Mid	2	<b>22.40</b>	<b>0.174</b>	
		50%	#Max	2	22.32	0.171	
		100%	--	2	21.08	0.128	

Band	Frequency Channel	Modulation	RB No.	RB Offset	MPR	Max Power (Conducted)	Max Power (W)
Band 2 (1900MHz)/3MHz	1851.5MHz CH18615	QPSK	1	#0	0	23.19	0.208
			1	#Mid	0	<b>23.34</b>	<b>0.216</b>
			1	#Max	0	23.15	0.207
			50%	#0	1	22.43	0.175
			50%	#Mid	1	22.46	0.176
			50%	#Max	1	22.53	0.179
			100%	--	1	22.53	0.179
		16QAM	1	#0	1	<b>22.46</b>	<b>0.176</b>
			1	#Mid	1	22.24	0.167
			1	#Max	1	22.33	0.171
			50%	#0	2	21.05	0.127
			50%	#Mid	2	21.40	0.138
			50%	#Max	2	21.40	0.138
			100%	--	2	21.44	0.139
	1880MHz CH18900	QPSK	1	#0	0	22.98	0.199
			1	#Mid	0	<b>23.30</b>	<b>0.214</b>
			1	#Max	0	23.28	0.213
			50%	#0	1	22.16	0.164
			50%	#Mid	1	22.18	0.165
			50%	#Max	1	22.26	0.168
			100%	--	1	22.24	0.167
		16QAM	1	#0	1	22.10	0.162
			1	#Mid	1	<b>22.31</b>	<b>0.170</b>
			1	#Max	1	22.27	0.169
			50%	#0	2	21.22	0.132
			50%	#Mid	2	21.30	0.135
			50%	#Max	2	21.36	0.137
			100%	--	2	21.04	0.127
	1908.5MHz CH19185	QPSK	1	#0	0	23.06	0.202
			1	#Mid	0	<b>23.12</b>	<b>0.205</b>
			1	#Max	0	22.82	0.191
			50%	#0	1	22.09	0.162
			50%	#Mid	1	22.16	0.164
			50%	#Max	1	22.14	0.164
			100%	--	1	22.12	0.163
		16QAM	1	#0	1	21.92	0.156
1			#Mid	1	<b>22.05</b>	<b>0.160</b>	
1			#Max	1	22.02	0.159	
50%			#0	2	20.86	0.122	
50%			#Mid	2	20.97	0.125	
50%			#Max	2	21.07	0.128	
100%			--	2	21.26	0.134	

Band	Frequency Channel	Modulation	RB No.	RB Offset	MPR	Max Power (Conducted)	Max Power (W)
Band 2 (1900MHz)/5MHz	1852.5MHz CH18625	QPSK	1	#0	0	23.18	0.208
			1	#Mid	0	<b>23.32</b>	<b>0.215</b>
			1	#Max	0	23.15	0.207
			50%	#0	1	22.19	0.166
			50%	#Mid	1	22.24	0.167
			50%	#Max	1	22.28	0.169
			100%	--	1	22.30	0.170
		16QAM	1	#0	1	21.55	0.143
			1	#Mid	1	21.55	0.143
			1	#Max	1	<b>21.67</b>	<b>0.147</b>
			50%	#0	2	21.14	0.130
			50%	#Mid	2	21.18	0.131
			50%	#Max	2	21.18	0.131
			100%	--	2	21.26	0.134
	1880MHz CH18900	QPSK	1	#0	0	23.13	0.206
			1	#Mid	0	23.24	0.211
			1	#Max	0	<b>23.31</b>	<b>0.214</b>
			50%	#0	1	22.24	0.167
			50%	#Mid	1	22.30	0.170
			50%	#Max	1	22.28	0.169
			100%	--	1	22.24	0.167
		16QAM	1	#0	1	21.76	0.150
			1	#Mid	1	<b>21.82</b>	<b>0.152</b>
			1	#Max	1	21.67	0.147
			50%	#0	2	21.22	0.132
			50%	#Mid	2	21.19	0.132
			50%	#Max	2	21.18	0.131
			100%	--	2	21.38	0.137
	1907.5MHz CH19175	QPSK	1	#0	0	22.80	0.191
			1	#Mid	0	<b>23.06</b>	<b>0.202</b>
			1	#Max	0	22.97	0.198
			50%	#0	1	22.11	0.163
			50%	#Mid	1	22.16	0.164
50%			#Max	1	22.18	0.165	
100%			--	1	22.20	0.166	
16QAM		1	#0	1	22.12	0.163	
		1	#Mid	1	<b>22.22</b>	<b>0.167</b>	
		1	#Max	1	22.00	0.158	
		50%	#0	2	21.00	0.126	
		50%	#Mid	2	21.04	0.127	
		50%	#Max	2	21.08	0.128	
		100%	--	2	21.10	0.129	

Band	Frequency Channel	Modulation	RB No.	RB Offset	MPR	Max Power (Conducted)	Max Power (W)
Band 2 (1900MHz)/10MHz	1855MHz CH18650	QPSK	1	#0	0	22.98	0.199
			1	#Mid	0	<b>23.40</b>	<b>0.219</b>
			1	#Max	0	22.82	0.191
			50%	#0	1	22.24	0.167
			50%	#Mid	1	22.26	0.168
			50%	#Max	1	22.26	0.168
			100%	--	1	22.31	0.170
		16QAM	1	#0	1	--	--
			1	#Mid	1	--	--
			1	#Max	1	--	--
			50%	#0	2	--	--
			50%	#Mid	2	--	--
			50%	#Max	2	--	--
			100%	--	2	--	--
	1880MHz CH18900	QPSK	1	#0	0	22.78	0.190
			1	#Mid	0	<b>23.38</b>	<b>0.218</b>
			1	#Max	0	23.18	0.208
			50%	#0	1	22.22	0.167
			50%	#Mid	1	22.22	0.167
			50%	#Max	1	22.11	0.163
			100%	--	1	22.14	0.164
		16QAM	1	#0	1	--	--
			1	#Mid	1	--	--
			1	#Max	1	--	--
			50%	#0	2	--	--
			50%	#Mid	2	--	--
			50%	#Max	2	--	--
			100%	--	2	--	--
	1905MHz CH19150	QPSK	1	#0	0	22.71	0.187
			1	#Mid	0	<b>23.22</b>	<b>0.210</b>
1			#Max	0	23.00	0.200	
50%			#0	1	22.09	0.162	
50%			#Mid	1	22.11	0.163	
50%			#Max	1	22.08	0.161	
100%			--	1	22.09	0.162	
16QAM		1	#0	1	--	--	
		1	#Mid	1	--	--	
		1	#Max	1	--	--	
		50%	#0	2	--	--	
		50%	#Mid	2	--	--	
		50%	#Max	2	--	--	
		100%	--	2	--	--	



Band	Frequency Channel	Modulation	RB No.	RB Offset	MPR	Max Power (dBm)	Max Power (W)
Band 4 (1700MHz)/1.4MHz	1710.7MHz CH19957	QPSK	1	#0	0	24.19	0.262
			1	#Mid	0	24.16	0.261
			1	#Max	0	24.12	0.258
			50%	#0	1	24.28	0.268
			50%	#Mid	1	<b>24.36</b>	<b>0.273</b>
			50%	#Max	1	24.31	0.270
			100%	--	1	23.13	0.206
		16QAM	1	#0	1	22.95	0.197
			1	#Mid	1	22.49	0.177
			1	#Max	1	22.47	0.177
			50%	#0	2	23.15	0.207
			50%	#Mid	2	23.22	0.210
			50%	#Max	2	<b>23.34</b>	<b>0.216</b>
			100%	--	2	22.00	0.158
	1732.5MHz CH20175	QPSK	1	#0	0	<b>22.94</b>	<b>0.197</b>
			1	#Mid	0	22.86	0.193
			1	#Max	0	22.59	0.182
			50%	#0	1	22.91	0.195
			50%	#Mid	1	22.86	0.193
			50%	#Max	1	22.93	0.196
			100%	--	1	21.88	0.154
		16QAM	1	#0	1	21.43	0.139
			1	#Mid	1	21.38	0.137
			1	#Max	1	21.41	0.138
			50%	#0	2	21.90	0.155
			50%	#Mid	2	<b>21.94</b>	<b>0.156</b>
			50%	#Max	2	21.87	0.154
			100%	--	2	20.56	0.114
	1754.3MHz CH20393	QPSK	1	#0	0	22.63	0.183
			1	#Mid	0	22.69	0.186
			1	#Max	0	22.62	0.183
			50%	#0	1	22.62	0.183
			50%	#Mid	1	22.70	0.186
			50%	#Max	1	<b>22.77</b>	<b>0.189</b>
			100%	--	1	21.71	0.148
		16QAM	1	#0	1	21.31	0.135
1			#Mid	1	21.22	0.132	
1			#Max	1	21.31	0.135	
50%			#0	2	21.70	0.148	
50%			#Mid	2	<b>21.76</b>	<b>0.150</b>	
50%			#Max	2	21.69	0.148	
100%			--	2	20.47	0.111	

Band	Frequency Channel	Modulation	RB No.	RB Offset	MPR	Max Power (Conducted)	Max Power (W)
Band 4 (1700MHz)/3MHz	1711.5MHz CH19965	QPSK	1	#0	0	23.81	0.240
			1	#Mid	0	<b>24.11</b>	<b>0.258</b>
			1	#Max	0	23.75	0.237
			50%	#0	1	22.99	0.199
			50%	#Mid	1	22.89	0.195
			50%	#Max	1	22.88	0.194
			100%	--	1	22.93	0.196
		16QAM	1	#0	1	<b>23.00</b>	<b>0.200</b>
			1	#Mid	1	22.72	0.187
			1	#Max	1	22.09	0.162
			50%	#0	2	22.36	0.172
			50%	#Mid	2	22.06	0.161
			50%	#Max	2	22.03	0.160
			100%	--	2	22.07	0.161
	1732.5MHz CH20175	QPSK	1	#0	0	<b>23.03</b>	<b>0.201</b>
			1	#Mid	0	22.74	0.188
			1	#Max	0	22.65	0.184
			50%	#0	1	22.06	0.161
			50%	#Mid	1	21.93	0.156
			50%	#Max	1	21.97	0.157
			100%	--	1	21.90	0.155
		16QAM	1	#0	1	<b>21.98</b>	<b>0.158</b>
			1	#Mid	1	21.91	0.155
			1	#Max	1	21.65	0.146
			50%	#0	2	20.79	0.120
			50%	#Mid	2	20.80	0.120
			50%	#Max	2	20.56	0.114
			100%	--	2	20.92	0.124
	1753.5MHz CH20385	QPSK	1	#0	0	22.67	0.185
			1	#Mid	0	22.82	0.191
			1	#Max	0	<b>22.83</b>	<b>0.192</b>
			50%	#0	1	21.70	0.148
			50%	#Mid	1	21.82	0.152
			50%	#Max	1	21.81	0.152
			100%	--	1	21.74	0.149
		16QAM	1	#0	1	21.74	0.149
1			#Mid	1	<b>21.99</b>	<b>0.158</b>	
1			#Max	1	21.39	0.138	
50%			#0	2	20.78	0.120	
50%			#Mid	2	20.88	0.122	
50%			#Max	2	20.88	0.122	
100%			--	2	20.68	0.117	

Band	Frequency Channel	Modulation	RB No.	RB Offset	MPR	Max Power (Conducted)	Max Power (W)
Band 4 (1700MHz)/5MHz	1712.5MHz CH19975	QPSK	1	#0	0	<b>24.01</b>	<b>0.252</b>
			1	#Mid	0	23.86	0.243
			1	#Max	0	23.70	0.234
			50%	#0	1	22.99	0.199
			50%	#Mid	1	22.92	0.196
			50%	#Max	1	22.77	0.189
			100%	--	1	22.77	0.189
		16QAM	1	#0	1	<b>22.46</b>	<b>0.176</b>
			1	#Mid	1	22.45	0.176
			1	#Max	1	22.26	0.168
			50%	#0	2	22.07	0.161
			50%	#Mid	2	21.81	0.152
			50%	#Max	2	21.85	0.153
			100%	--	2	21.88	0.154
	1732.5MHz CH20175	QPSK	1	#0	0	22.67	0.185
			1	#Mid	0	<b>22.89</b>	<b>0.195</b>
			1	#Max	0	22.64	0.184
			50%	#0	1	22.00	0.158
			50%	#Mid	1	21.99	0.158
			50%	#Max	1	21.86	0.153
			100%	--	1	21.90	0.155
		16QAM	1	#0	1	<b>21.74</b>	<b>0.149</b>
			1	#Mid	1	21.61	0.145
			1	#Max	1	21.56	0.143
			50%	#0	2	20.86	0.122
			50%	#Mid	2	21.05	0.127
			50%	#Max	2	20.64	0.116
			100%	--	2	20.99	0.126
	1752.5MHz CH20375	QPSK	1	#0	0	22.55	0.180
			1	#Mid	0	<b>22.92</b>	<b>0.196</b>
1			#Max	0	22.71	0.187	
50%			#0	1	21.76	0.150	
50%			#Mid	1	21.94	0.156	
50%			#Max	1	21.88	0.154	
100%			--	1	21.86	0.153	
16QAM		1	#0	1	21.94	0.156	
		1	#Mid	1	<b>21.95</b>	<b>0.157</b>	
		1	#Max	1	21.74	0.149	
		50%	#0	2	20.62	0.115	
		50%	#Mid	2	20.70	0.117	
		50%	#Max	2	20.93	0.124	
		100%	--	2	21.01	0.126	

Band	Frequency Channel	Modulation	RB No.	RB Offset	MPR	Max Power (Conducted)	Max Power (W)
Band 4 (1700MHz)/10MHz	1715MHz CH20000	QPSK	1	#0	0	23.93	0.247
			1	#Mid	0	<b>23.95</b>	<b>0.248</b>
			1	#Max	0	23.16	0.207
			50%	#0	1	22.77	0.189
			50%	#Mid	1	22.75	0.188
			50%	#Max	1	22.43	0.175
			100%	--	1	22.58	0.181
		16QAM	1	#0	1	--	--
			1	#Mid	1	--	--
			1	#Max	1	--	--
			50%	#0	2	--	--
			50%	#Mid	2	--	--
			50%	#Max	2	--	--
			100%	--	2	--	--
	1732.5MHz CH20175	QPSK	1	#0	0	22.62	0.183
			1	#Mid	0	<b>22.92</b>	<b>0.196</b>
			1	#Max	0	22.46	0.176
			50%	#0	1	21.96	0.157
			50%	#Mid	1	21.97	0.157
			50%	#Max	1	21.92	0.156
			100%	--	1	21.91	0.155
		16QAM	1	#0	1	--	--
			1	#Mid	1	--	--
			1	#Max	1	--	--
			50%	#0	2	--	--
			50%	#Mid	2	--	--
			50%	#Max	2	--	--
			100%	--	2	--	--
	1750MHz CH20350	QPSK	1	#0	0	22.66	0.185
			1	#Mid	0	<b>22.96</b>	<b>0.198</b>
1			#Max	0	22.64	0.184	
50%			#0	1	21.88	0.154	
50%			#Mid	1	21.91	0.155	
50%			#Max	1	21.78	0.151	
100%			--	1	22.00	0.158	
16QAM		1	#0	1	--	--	
		1	#Mid	1	--	--	
		1	#Max	1	--	--	
		50%	#0	2	--	--	
		50%	#Mid	2	--	--	
		50%	#Max	2	--	--	
		100%	--	2	--	--	

Band	Frequency Channel	Modulation	RB No.	RB Offset	MPR	Max Power (Conducted)	Max Power (W)
Band 12 (700MHz)/1.4MHz	699.7MHz CH23017	QPSK	1	#0	0	22.93	0.196
			1	#Mid	0	<b>22.97</b>	<b>0.198</b>
			1	#Max	0	22.86	0.193
			50%	#0	1	22.96	0.198
			50%	#Mid	1	22.84	0.192
			50%	#Max	1	22.89	0.195
			100%	--	1	21.91	0.155
		16QAM	1	#0	1	21.62	0.145
			1	#Mid	1	21.57	0.144
			1	#Max	1	21.49	0.141
			50%	#0	2	21.91	0.155
			50%	#Mid	2	<b>22.06</b>	<b>0.161</b>
			50%	#Max	2	21.82	0.152
			100%	--	2	20.76	0.119
	707.5MHz CH23095	QPSK	1	#0	0	22.73	0.187
			1	#Mid	0	22.68	0.185
			1	#Max	0	22.64	0.184
			50%	#0	1	<b>22.87</b>	<b>0.194</b>
			50%	#Mid	1	22.78	0.190
			50%	#Max	1	22.77	0.189
			100%	--	1	21.74	0.149
		16QAM	1	#0	1	21.24	0.133
			1	#Mid	1	21.62	0.145
			1	#Max	1	21.78	0.151
			50%	#0	2	<b>22.08</b>	<b>0.161</b>
			50%	#Mid	2	22.01	0.159
			50%	#Max	2	21.63	0.146
			100%	--	2	20.64	0.116
	715.3MHz CH23173	QPSK	1	#0	0	22.86	0.193
			1	#Mid	0	22.92	0.196
			1	#Max	0	22.90	0.195
			50%	#0	1	22.92	0.196
			50%	#Mid	1	22.91	0.195
			50%	#Max	1	<b>23.10</b>	<b>0.204</b>
			100%	--	1	21.93	0.156
		16QAM	1	#0	1	21.45	0.140
			1	#Mid	1	21.62	0.145
			1	#Max	1	21.81	0.152
			50%	#0	2	21.59	0.144
			50%	#Mid	2	21.96	0.157
			50%	#Max	2	<b>22.11</b>	<b>0.163</b>
			100%	--	2	20.80	0.120

Band	Frequency Channel	Modulation	RB No.	RB Offset	MPR	Max Power (Conducted)	Max Power (W)
Band 12 (700MHz)/3MHz	700.5MHz CH23025	QPSK	1	#0	0	22.78	0.190
			1	#Mid	0	<b>23.02</b>	<b>0.200</b>
			1	#Max	0	22.66	0.185
			50%	#0	1	21.99	0.158
			50%	#Mid	1	21.96	0.157
			50%	#Max	1	22.00	0.158
			100%	--	1	21.96	0.157
		16QAM	1	#0	1	21.75	0.150
			1	#Mid	1	<b>21.85</b>	<b>0.153</b>
			1	#Max	1	21.67	0.147
			50%	#0	2	20.88	0.122
			50%	#Mid	2	21.02	0.126
			50%	#Max	2	21.27	0.134
			100%	--	2	20.96	0.125
	707.5MHz CH23095	QPSK	1	#0	0	<b>22.80</b>	<b>0.191</b>
			1	#Mid	0	22.53	0.179
			1	#Max	0	22.30	0.170
			50%	#0	1	21.72	0.149
			50%	#Mid	1	21.79	0.151
			50%	#Max	1	21.88	0.154
			100%	--	1	21.76	0.150
		16QAM	1	#0	1	21.51	0.142
			1	#Mid	1	21.18	0.131
			1	#Max	1	<b>21.52</b>	<b>0.142</b>
			50%	#0	2	20.87	0.122
			50%	#Mid	2	20.83	0.121
			50%	#Max	2	20.91	0.123
			100%	--	2	20.84	0.121
	714.5MHz CH23165	QPSK	1	#0	0	22.67	0.185
			1	#Mid	0	<b>23.33</b>	<b>0.215</b>
			1	#Max	0	23.07	0.203
			50%	#0	1	22.01	0.159
			50%	#Mid	1	22.26	0.168
			50%	#Max	1	22.30	0.170
			100%	--	1	22.27	0.169
		16QAM	1	#0	1	21.72	0.149
1			#Mid	1	<b>22.16</b>	<b>0.164</b>	
1			#Max	1	21.92	0.156	
50%			#0	2	21.16	0.131	
50%			#Mid	2	21.21	0.132	
50%			#Max	2	21.36	0.137	
100%			--	2	21.25	0.133	

Band	Frequency Channel	Modulation	RB No.	RB Offset	MPR	Max Power (Conducted)	Max Power (W)
Band 12 (700MHz)/5MHz	701.5MHz CH23035	QPSK	1	#0	0	22.85	0.193
			1	#Mid	0	<b>23.19</b>	<b>0.208</b>
			1	#Max	0	22.94	0.197
			50%	#0	1	21.89	0.155
			50%	#Mid	1	21.92	0.156
			50%	#Max	1	21.86	0.153
			100%	--	1	21.78	0.151
		16QAM	1	#0	1	21.56	0.143
			1	#Mid	1	<b>21.61</b>	<b>0.145</b>
			1	#Max	1	21.32	0.136
			50%	#0	2	20.77	0.119
			50%	#Mid	2	20.83	0.121
			50%	#Max	2	20.85	0.122
			100%	--	2	20.76	0.119
	707.5MHz CH23095	QPSK	1	#0	0	22.55	0.180
			1	#Mid	0	<b>22.74</b>	<b>0.188</b>
			1	#Max	0	22.34	0.171
			50%	#0	1	21.73	0.149
			50%	#Mid	1	21.71	0.148
			50%	#Max	1	21.72	0.149
			100%	--	1	21.73	0.149
		16QAM	1	#0	1	21.32	0.136
			1	#Mid	1	<b>21.41</b>	<b>0.138</b>
			1	#Max	1	21.16	0.131
			50%	#0	2	20.93	0.124
			50%	#Mid	2	20.61	0.115
			50%	#Max	2	20.64	0.116
			100%	--	2	20.81	0.121
	713.5MHz CH23155	QPSK	1	#0	0	22.44	0.175
			1	#Mid	0	<b>23.14</b>	<b>0.206</b>
			1	#Max	0	23.07	0.203
			50%	#0	1	21.79	0.151
			50%	#Mid	1	21.96	0.157
			50%	#Max	1	22.11	0.163
			100%	--	1	21.88	0.154
		16QAM	1	#0	1	21.32	0.136
1			#Mid	1	21.26	0.134	
1			#Max	1	<b>21.57</b>	<b>0.144</b>	
50%			#0	2	20.77	0.119	
50%			#Mid	2	20.75	0.119	
50%			#Max	2	21.04	0.127	
100%			--	2	21.05	0.127	

Band	Frequency Channel	Modulation	RB No.	RB Offset	MPR	Max Power (Conducted)	Max Power (W)
Band 12 (700MHz)/10MHz	704MHz CH23060	QPSK	1	#0	0	22.43	0.175
			1	#Mid	0	<b>22.98</b>	<b>0.199</b>
			1	#Max	0	22.49	0.177
			50%	#0	1	21.80	0.151
			50%	#Mid	1	21.90	0.155
			50%	#Max	1	21.81	0.152
			100%	--	1	21.80	0.151
		16QAM	1	#0	1	--	--
			1	#Mid	1	--	--
			1	#Max	1	--	--
			50%	#0	2	--	--
			50%	#Mid	2	--	--
			50%	#Max	2	--	--
			100%	--	2	--	--
	707.5MHz CH23095	QPSK	1	#0	0	22.34	0.171
			1	#Mid	0	<b>22.81</b>	<b>0.191</b>
			1	#Max	0	22.74	0.188
			50%	#0	1	21.85	0.153
			50%	#Mid	1	21.75	0.150
			50%	#Max	1	21.71	0.148
			100%	--	1	21.59	0.144
		16QAM	1	#0	1	--	--
			1	#Mid	1	--	--
			1	#Max	1	--	--
			50%	#0	2	--	--
			50%	#Mid	2	--	--
			50%	#Max	2	--	--
			100%	--	2	--	--
	711MHz CH23130	QPSK	1	#0	0	22.44	0.175
			1	#Mid	0	22.51	0.178
			1	#Max	0	<b>22.92</b>	0.196
			50%	#0	1	21.52	0.142
			50%	#Mid	1	21.78	0.151
			50%	#Max	1	21.82	0.152
			100%	--	1	21.70	0.148
		16QAM	1	#0	1	--	--
1			#Mid	1	--	--	
1			#Max	1	--	--	
50%			#0	2	--	--	
50%			#Mid	2	--	--	
50%			#Max	2	--	--	
100%			--	2	--	--	



### 3.6. Test Result of Maximum Power Output

According to KDB 412172 D01 Section 1.2 Power Approach

$EIRP = PT + GT - LC = ERP + 2.15 \text{ dB}$ ,  $ERP = EIRP - 2.15 \text{ dB}$

PT = transmitter output power in dBm

GT = gain of the transmitting antenna in dBi

LC = signal attenuation in the connecting cable between the transmitter and antenna in dB

LTE Band	BW	Modulation	Conducted Peak Power (dBm)	Conducted Peak Power (W)	Antenna Gain (dBi)	Maximum ERP/EIRP (W)	Maximum ERP/EIRP Limit (W)
2	1.4M	QPSK	23.63	0.231	2.37	0.398	2
		16QAM	22.47	0.177	2.37	0.305	2
	3M	QPSK	23.34	0.216	2.37	0.372	2
		16QAM	22.46	0.176	2.37	0.304	2
	5M	QPSK	23.32	0.215	2.37	0.371	2
		16QAM	22.22	0.167	2.37	0.288	2
10M	QPSK	23.40	0.219	2.37	0.378	2	
4	1.4M	QPSK	24.36	0.273	2.37	0.471	1
		16QAM	23.34	0.216	2.37	0.372	1
	3M	QPSK	24.11	0.258	2.37	0.445	1
		16QAM	23.00	0.200	2.37	0.344	1
	5M	QPSK	24.01	0.252	2.37	0.435	1
		16QAM	22.46	0.176	2.37	0.304	1
10M	QPSK	23.95	0.248	2.37	0.429	1	
12	1.4M	QPSK	23.10	0.204	0.99	0.156	3
		16QAM	22.11	0.163	0.99	0.124	3
	3M	QPSK	23.33	0.215	0.99	0.165	3
		16QAM	22.16	0.164	0.99	0.126	3
	5M	QPSK	23.19	0.208	0.99	0.160	3
		16QAM	21.61	0.145	0.99	0.111	3
10M	QPSK	22.98	0.199	0.99	0.152	3	

## 4. Occupied Bandwidth

### 4.1. Test Secification

According to FCC Part 2.1049, 24.238, 27.53  
RSS GEN, RSS 130, RSS 133, RSS 139

### 4.2. Test Setup

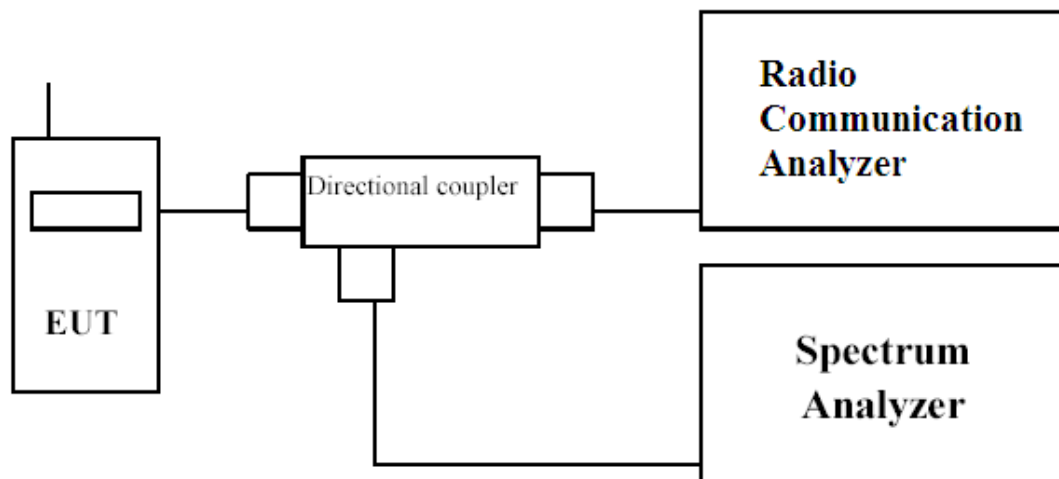

### 4.3. Test Procedure

The EUT is tested with maximum rated TX power via the Base Station simulator, and the occupied bandwidth was measured at the antenna terminals of the EUT.

The Resolution BW of the analyzer is set to 1 %~5% of the emission bandwidth. The EUT's occupied bandwidth is measured as the width of the signal between two points, one below the carrier center frequency and one above the carrier frequency, outside of which all emissions are attenuated at least 26 dB below the transmitter power.

The plots below show the resultant display from the Spectrum Analyzer.

#### 4.4. Test Result of Occupied Bandwidth

Product	LE910C1-NA
Test Mode	Occupied Bandwidth
Test Site	CTR

Test Mode	Channel	TX Frequency (MHz)	99% Occupied Bandwidth (MHz)	26 dB bandwidth (MHz)	Result
Band 2 1.4M QPSK	18900	1880	1.0988	1.294	Pass
Band 2 1.4M 16QAM	18900	1880	1.0956	1.318	Pass
Band 2 3M QPSK	18900	1880	2.7364	3.072	Pass
Band 2 3M 16QAM	18900	1880	2.7203	3.043	Pass
Band 2 5M QPSK	18900	1880	4.5046	5.011	Pass
Band 2 5M 16QAM	18900	1880	4.4887	4.958	Pass
Band 2 10M QPSK	18900	1880	9.0360	10.02	Pass
Band 4 1.4M QPSK	20175	1732.5	1.0987	1.303	Pass
Band 4 1.4M 16QAM	20175	1732.5	1.0958	1.310	Pass
Band 4 3M QPSK	20175	1732.5	2.7341	3.068	Pass
Band 4 3M 16QAM	20175	1732.5	2.7203	3.051	Pass
Band 4 5M QPSK	20175	1732.5	4.5053	4.998	Pass
Band 4 5M 16QAM	20175	1732.5	4.4862	4.954	Pass
Band 4 10M QPSK	20175	1732.5	9.0366	10.00	Pass
Band 12 1.4M QPSK	23095	707.5	1.0982	1.292	Pass
Band 12 1.4M 16QAM	23095	707.5	1.0941	1.299	Pass
Band 12 3M QPSK	23095	707.5	2.7315	3.081	Pass
Band 12 3M 16QAM	23095	707.5	2.7176	3.051	Pass
Band 12 5M QPSK	23095	707.5	4.4974	4.980	Pass
Band 12 5M 16QAM	23095	707.5	4.4809	4.952	Pass
Band 12 10M QPSK	23095	707.5	8.9699	9.971	Pass

Product	LE910C1-NA		
Test Mode	Occupied Bandwidth		
Date of Test	2017/01/10	Test Site	CTR
Test Condition	Band 2 1.4M		

Band 2 1.4M QPSK - LTE Mode CH18900 (1880MHz)

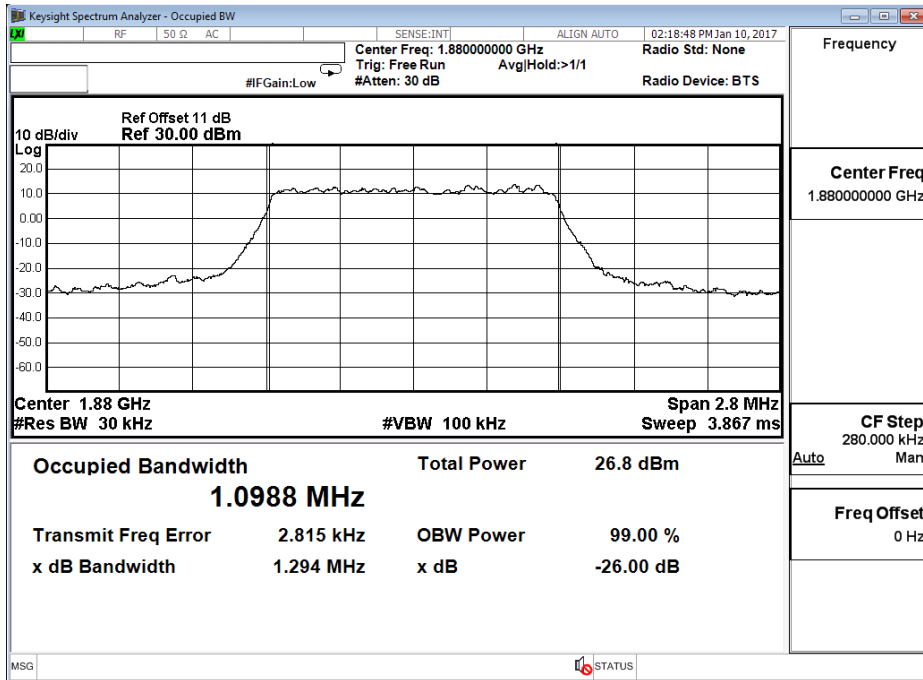

Band 2 1.4M 16QAM - LTE Mode CH18900 (1880MHz)

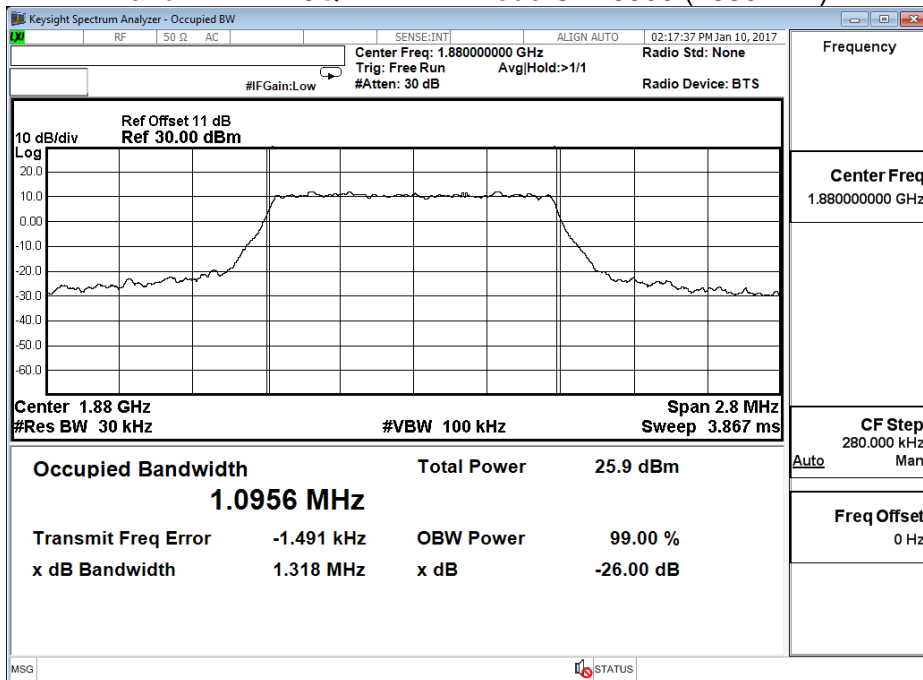

Product	LE910C1-NA		
Test Mode	Occupied Bandwidth		
Date of Test	2017/01/10	Test Site	CTR
Test Condition	Band 2 3M		

Band 2 3M QPSK - LTE Mode CH18900 (1880MHz)

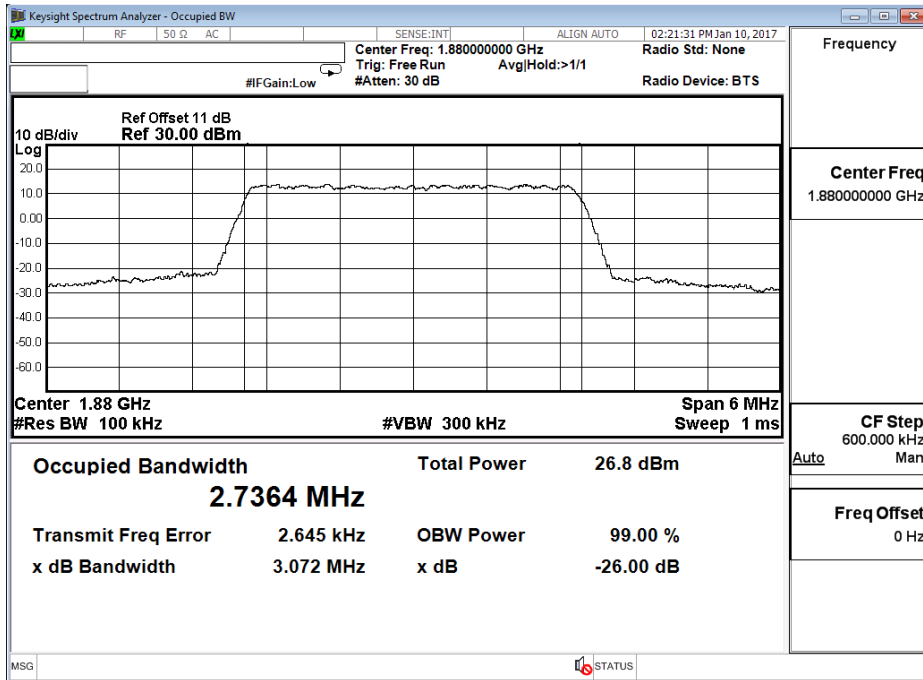

Band 2 3M 16QAM - LTE Mode CH18900 (1880MHz)

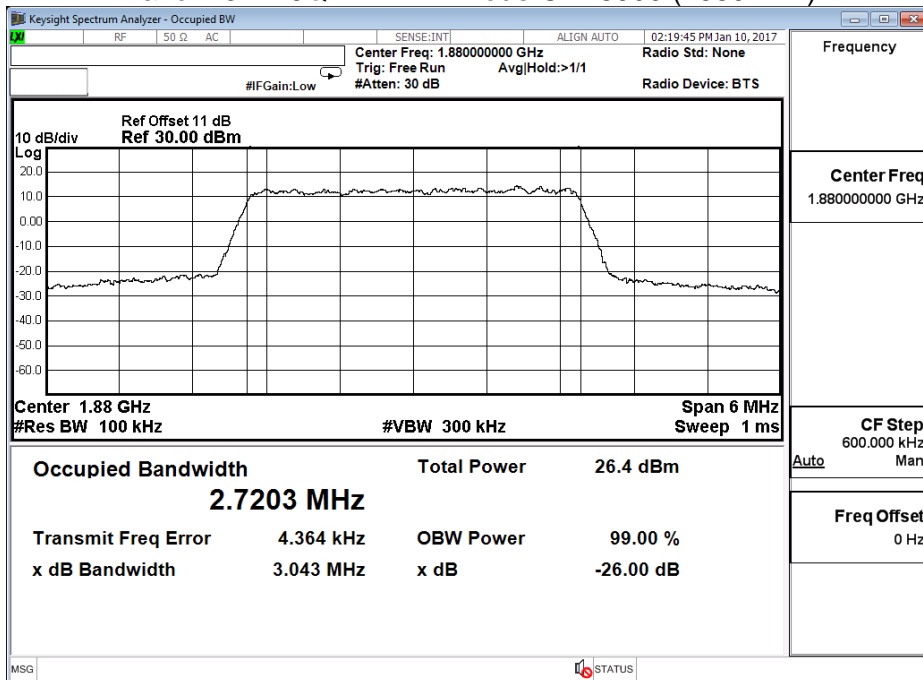

Product	LE910C1-NA		
Test Mode	Occupied Bandwidth		
Date of Test	2017/01/10	Test Site	CTR
Test Condition	Band 2 5M		

Band 2 5M QPSK - LTE Mode CH18900 (1880MHz)

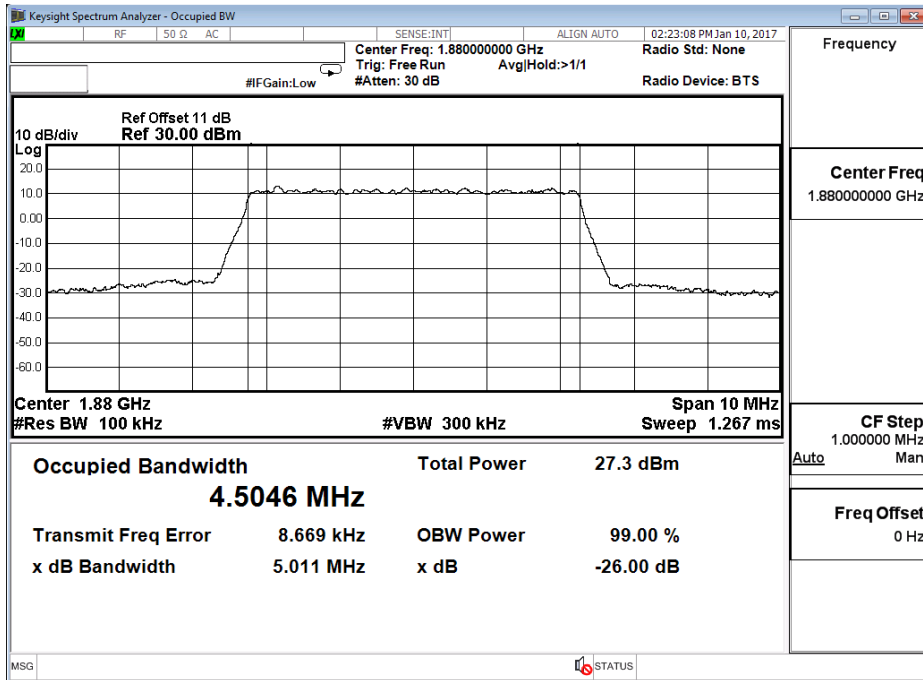

Band 2 5M 16QAM - LTE Mode CH18900 (1880MHz)

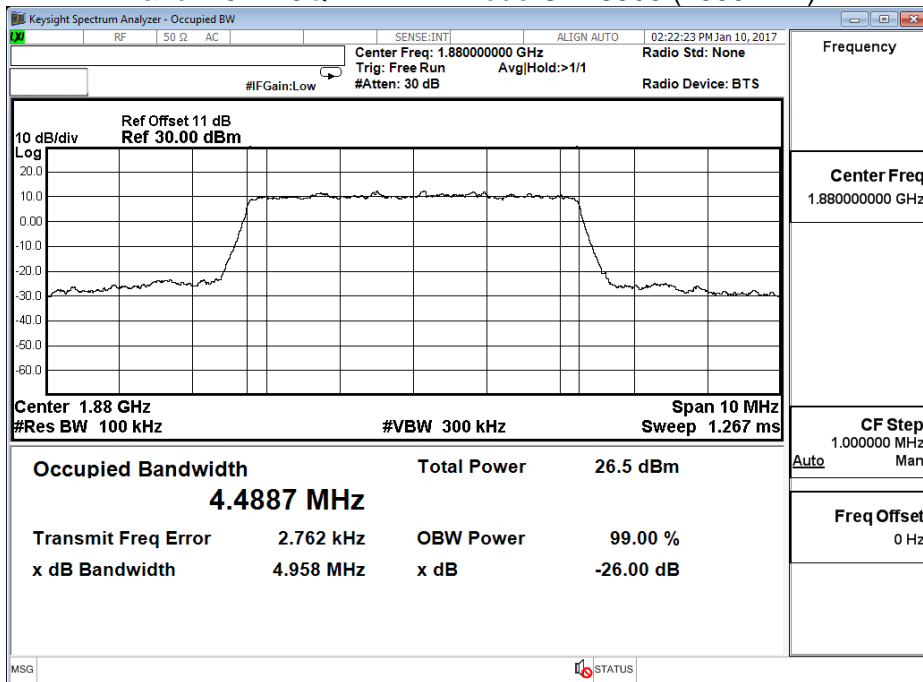

Product	LE910C1-NA		
Test Mode	Occupied Bandwidth		
Date of Test	2017/01/10	Test Site	CTR
Test Condition	Band 2 10M		

Band 2 10M QPSK - LTE Mode CH18900 (1880MHz)

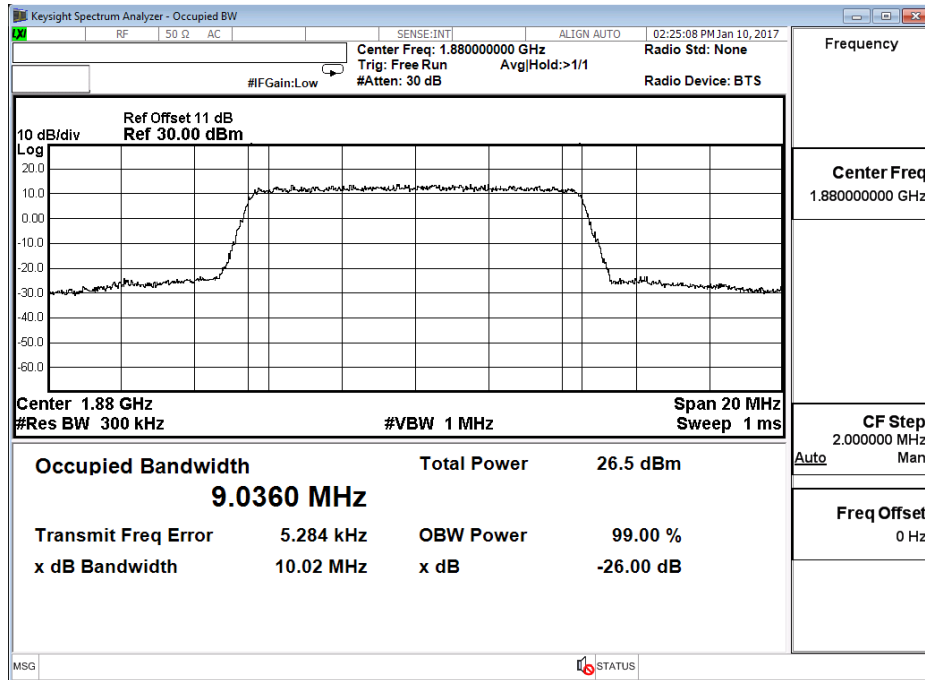

Product	LE910C1-NA		
Test Mode	Occupied Bandwidth		
Date of Test	2017/01/10	Test Site	CTR
Test Condition	Band 4 1.4M		

Band 4 1.4M QPSK - LTE Mode CH 20175 (1732.5MHz)

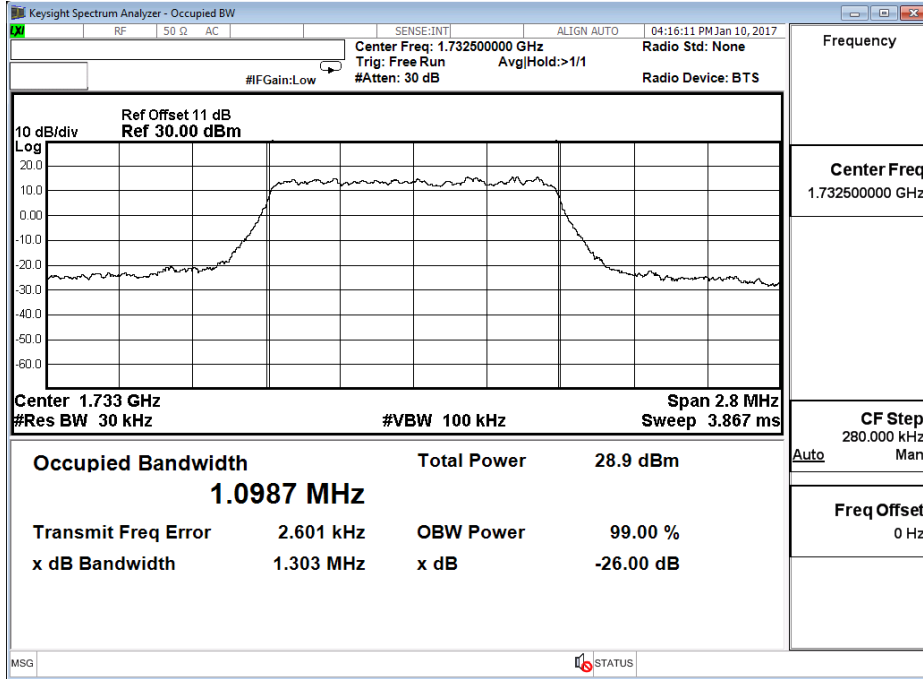

Band 4 1.4M 16QAM - LTE Mode CH20175 (1732.5MHz)

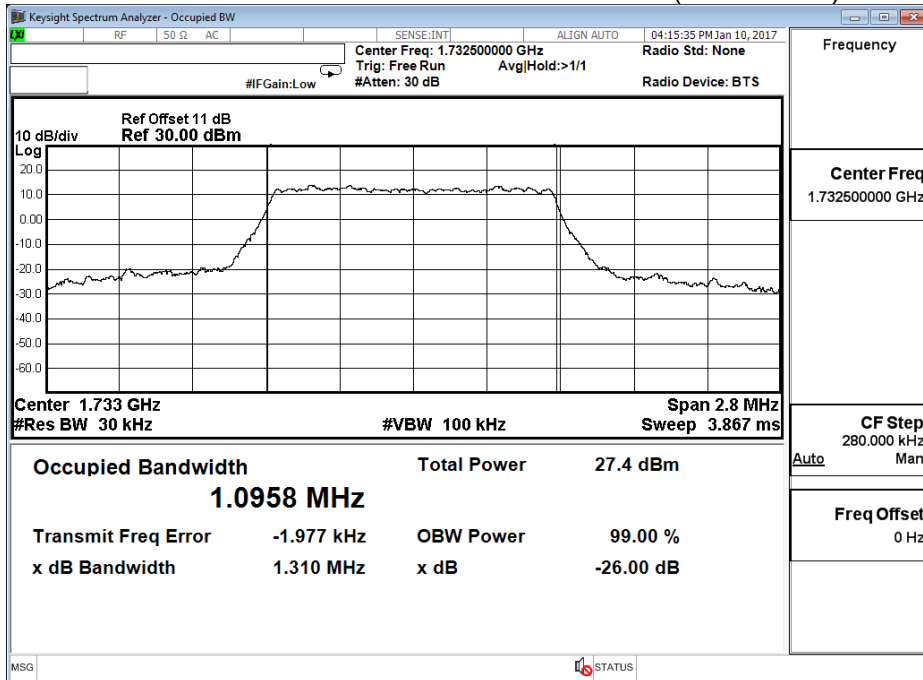



Product	LE910C1-NA		
Test Mode	Occupied Bandwidth		
Date of Test	2017/01/10	Test Site	CTR
Test Condition	Band 4 3M		

Band 4 3M QPSK - LTE Mode CH20175 (1732.5MHz)

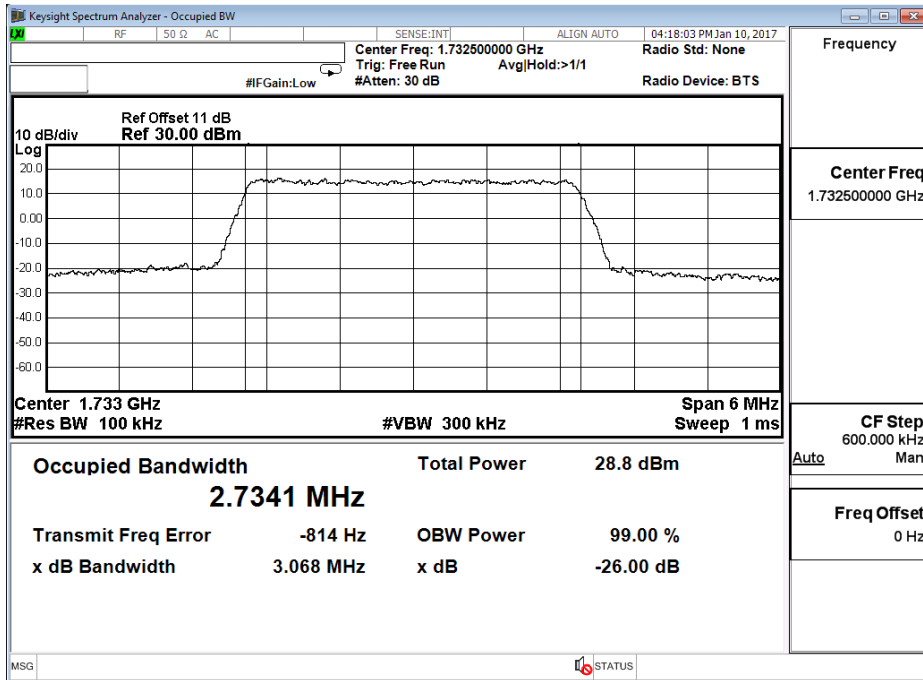

Band 4 3M 16QAM - LTE Mode CH20175 (1732.5MHz)

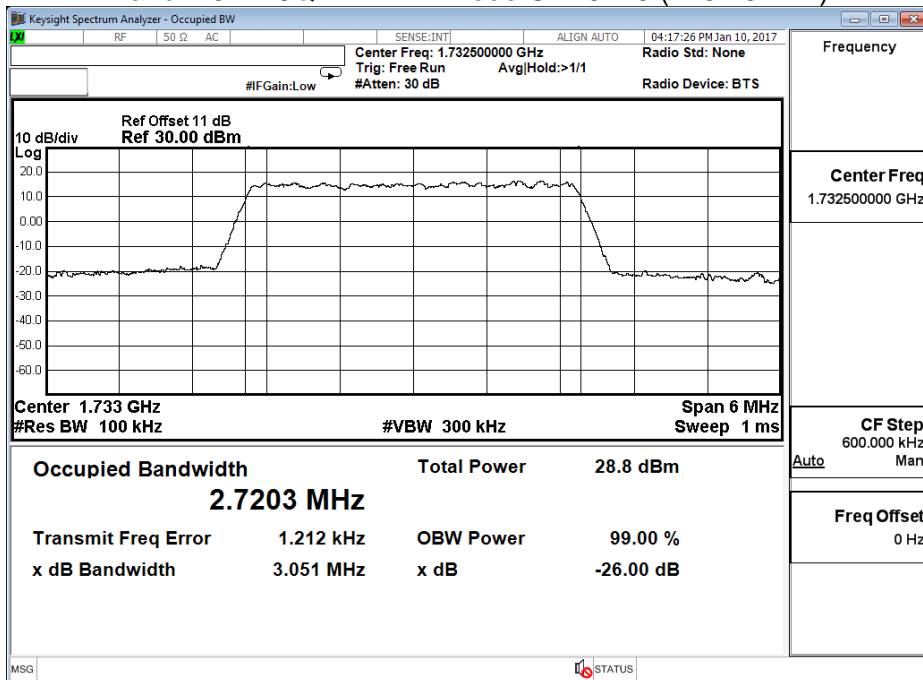

Product	LE910C1-NA		
Test Mode	Occupied Bandwidth		
Date of Test	2017/01/10	Test Site	CTR
Test Condition	Band 4 5M		

Band 4 5M QPSK - LTE Mode CH20175 (1732.5MHz)

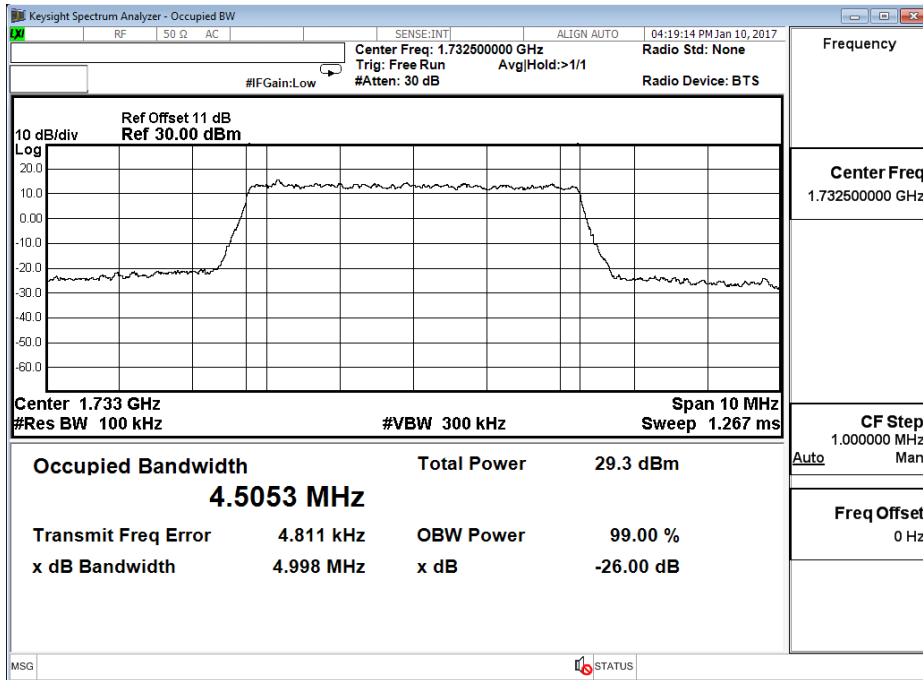

Band 4 5M 16QAM - LTE Mode CH20175 (1732.5MHz)

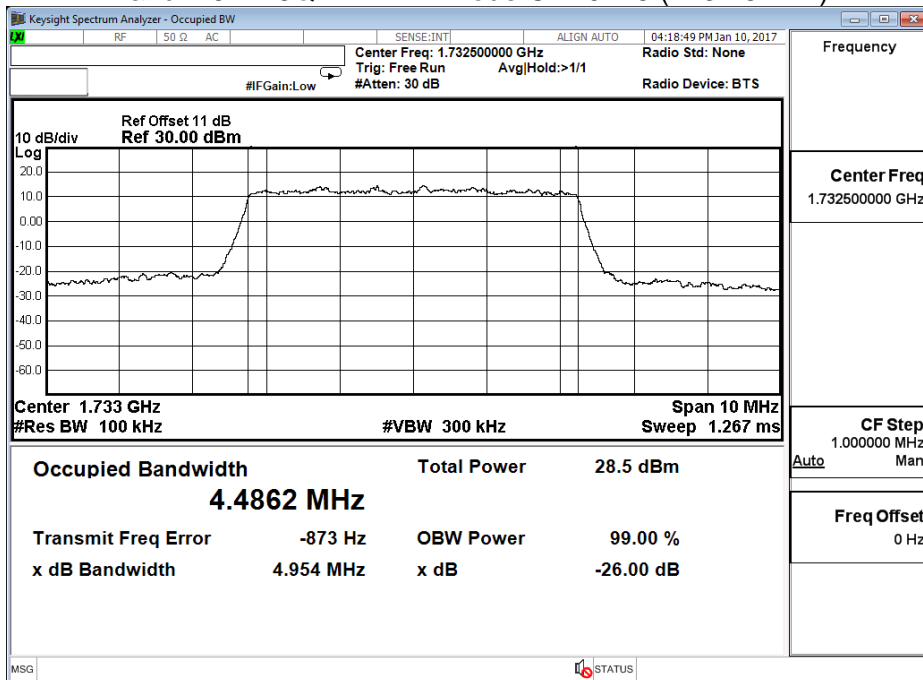

Product	LE910C1-NA		
Test Mode	Occupied Bandwidth		
Date of Test	2017/01/10	Test Site	CTR
Test Condition	Band 4 10M		

Band 4 10M QPSK - LTE Mode CH20175 (1732.5MHz)

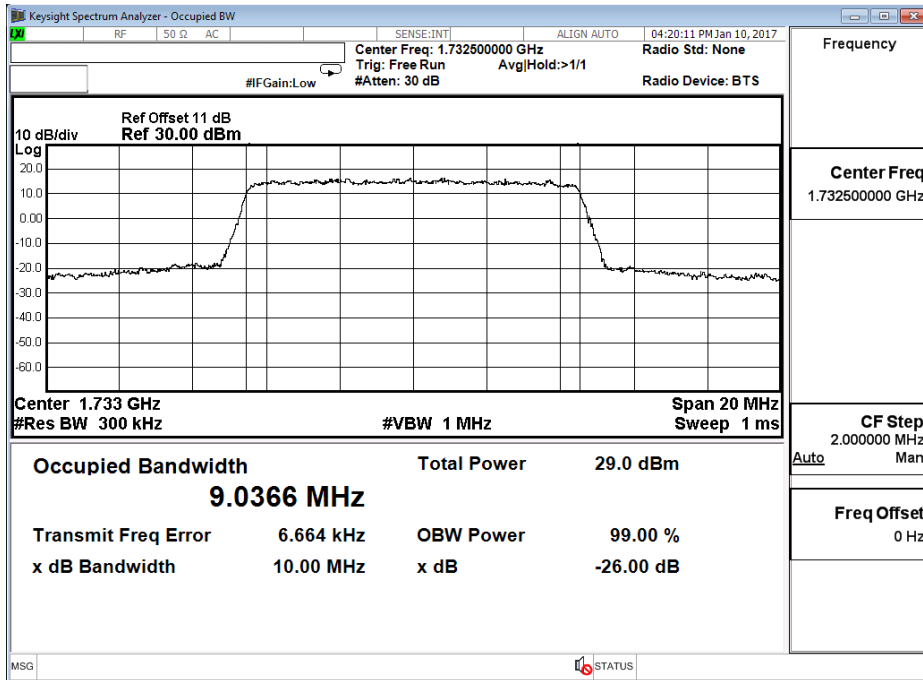

Product	LE910C1-NA		
Test Mode	Occupied Bandwidth		
Date of Test	2017/01/10	Test Site	CTR
Test Condition	Band 12 1.4M		

Band 12 1.4M QPSK - LTE Mode CH23095 (707.5MHz)

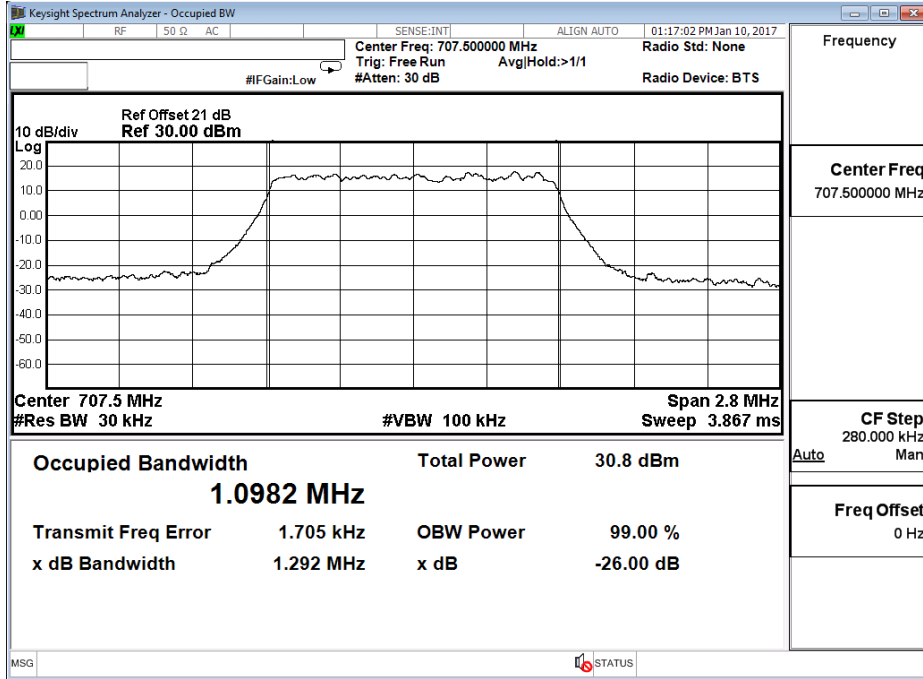

Band 12 1.4M 16QAM - LTE Mode CH23095 (707.5MHz)

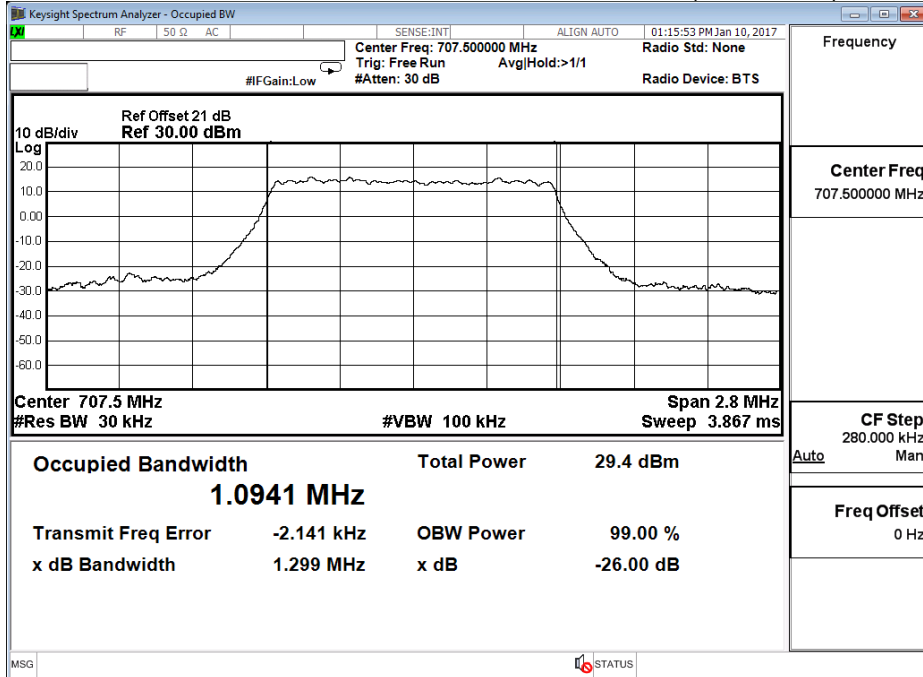

Product	LE910C1-NA		
Test Mode	Occupied Bandwidth		
Date of Test	2017/01/10	Test Site	CTR
Test Condition	Band 12 3M		

Band 12 3M QPSK - LTE Mode CH23095 (707.5MHz)

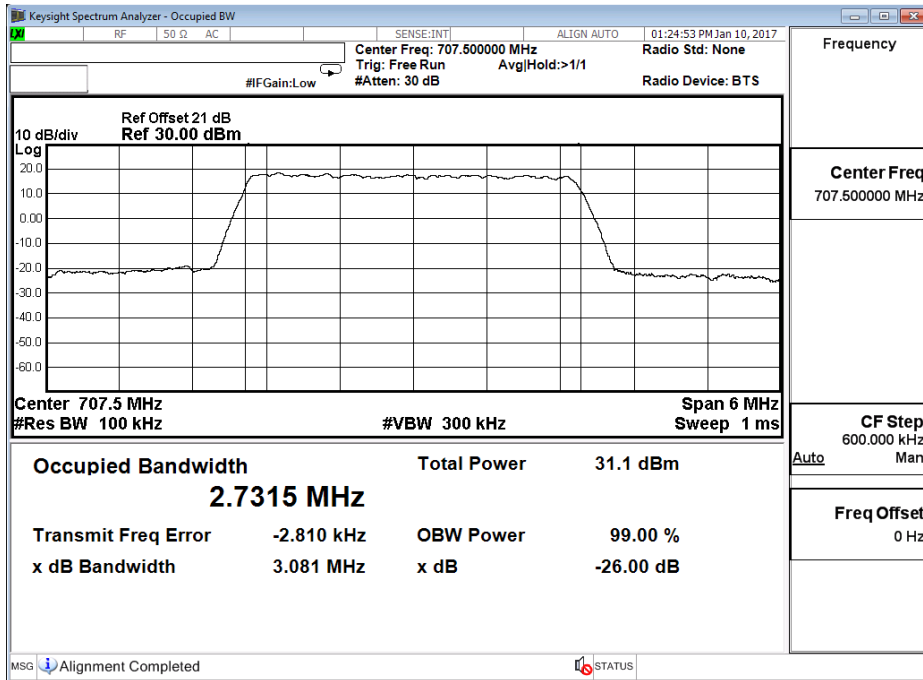

Band 12 3M 16QAM - LTE Mode CH23095 (707.5MHz)

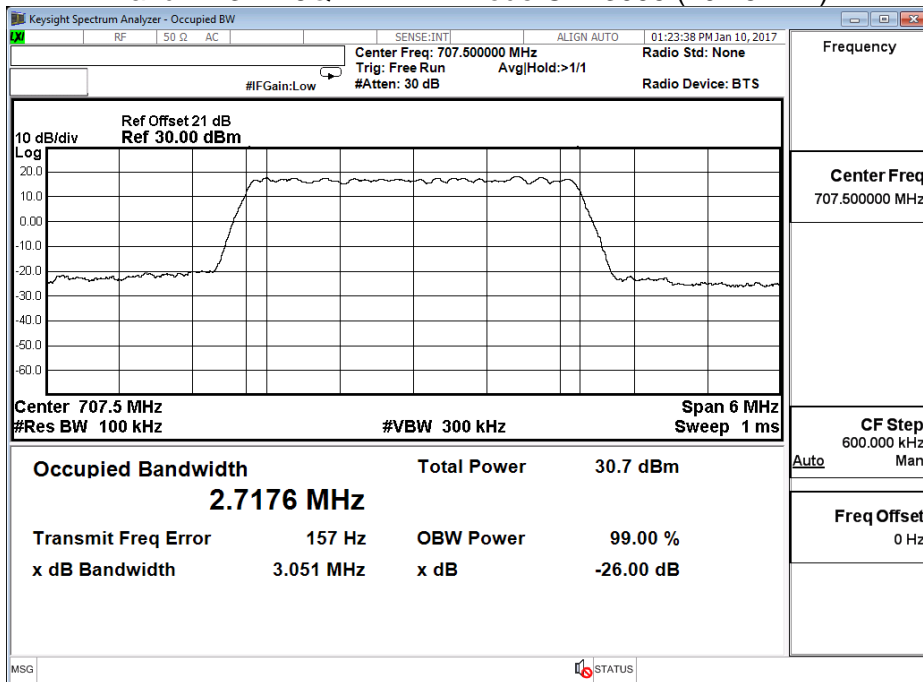

Product	LE910C1-NA		
Test Mode	Occupied Bandwidth		
Date of Test	2017/01/10	Test Site	CTR
Test Condition	Band 12 5M		

Band 12 5M QPSK - LTE Mode CH23095 (707.5MHz)

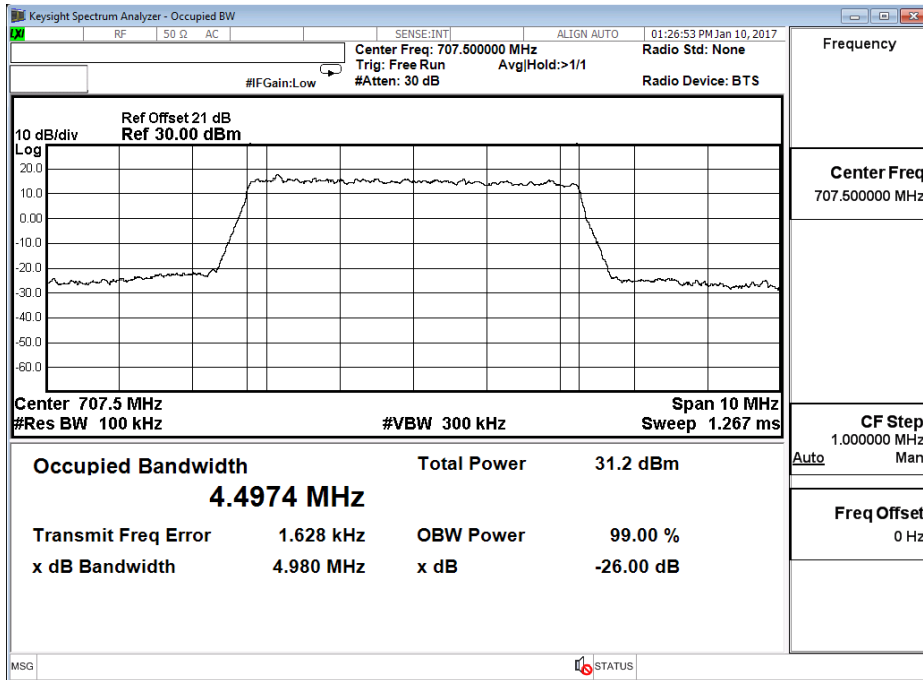

Band 12 5M 16QAM - LTE Mode CH23095 (707.5MHz)

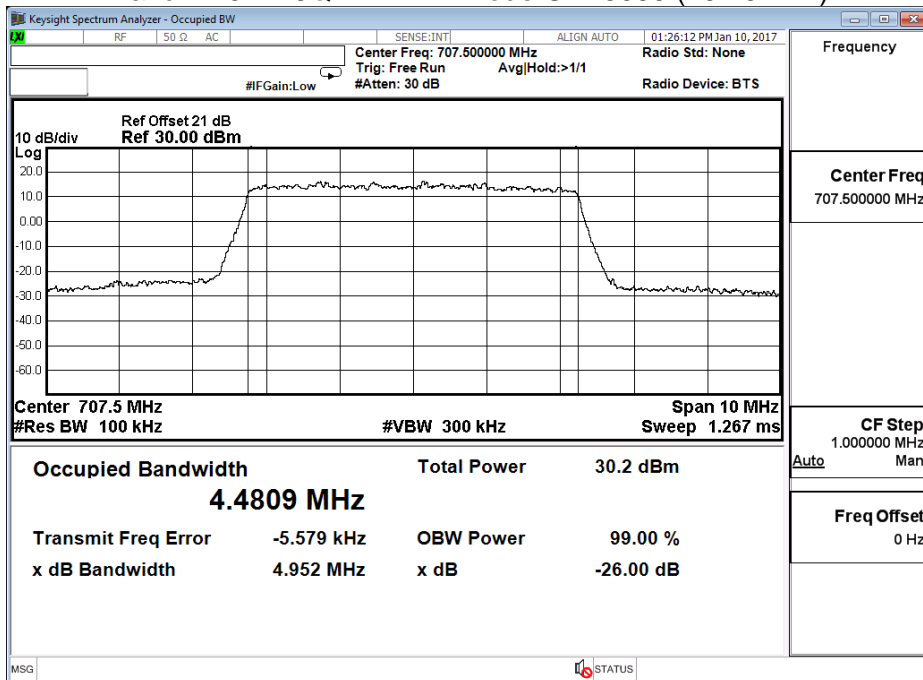

Product	LE910C1-NA		
Test Mode	Occupied Bandwidth		
Date of Test	2017/01/10	Test Site	CTR
Test Condition	Band 12 10M		

Band 12 10M QPSK - LTE Mode CH23095 (707.5MHz)

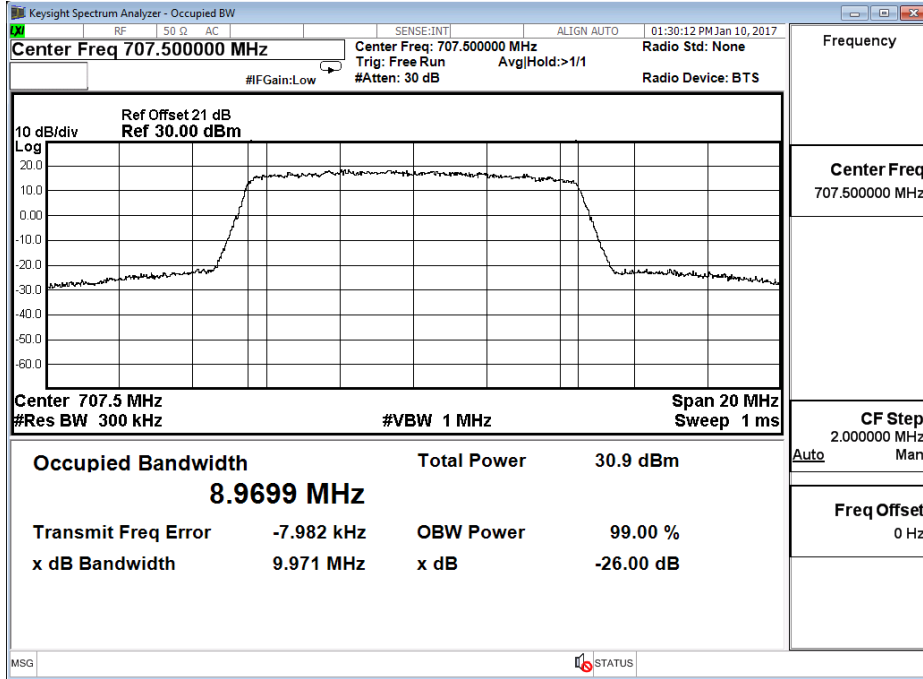

## 5. Spurious Emission At Antenna Terminals (+/-1MHz)

### 5.1. Test Specification

According to Part 2.1051, 24.238, 27.53  
RSS GEN, RSS 130, RSS 133, RSS 139

### 5.2. Setup

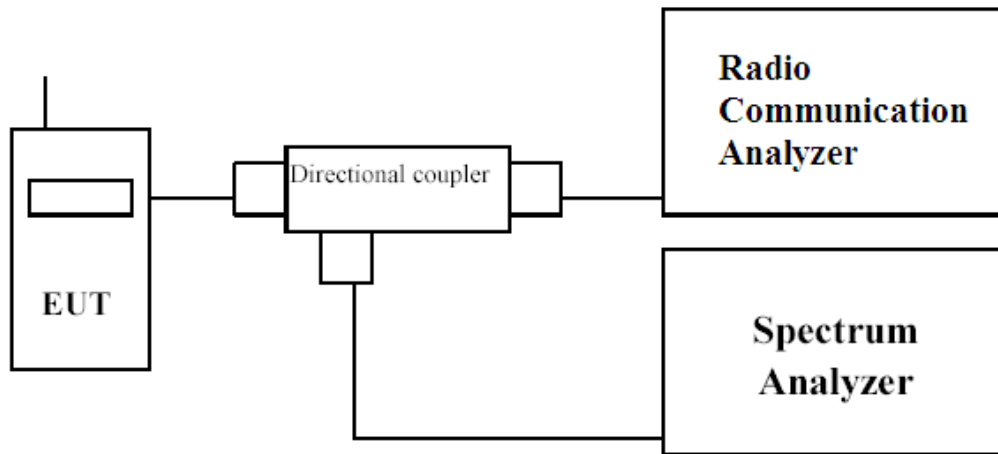

### 5.3. Limits

The spurious (unwanted) emission limits specified in the individual FCC rule parts applicable to licensed digital transmitters (typically referred to under the heading 'emission limits') normally apply to any and all emissions that are present outside of the authorized frequency band/block and apply to emissions in both the out-of-band and spurious domains. unwanted emissions are required by the licensed rule parts to be attenuated below the transmitter power by a factor of at least  $43 + 10\log(P)$  dB, where P represents the transmitter power expressed in watts

### 5.4. Test Procedure

In accordance with Part 24.238, 27.53, RSS 130, RSS 133, RSS 139 at least 1% of the emission bandwidth was used for the resolution and video bandwidths up to 1MHz away from the Block Edge. At greater than 1MHz, the resolution and video bandwidth were increased to 1MHz/3MHz.

The reference power and path losses of all channels used for testing in each frequency block were measured.



### 5.5. Test Result of Spurious Emission At Antenna Terminals (+/-1MHz)

Product	LE910C1-NA		
Test Mode	Spurious Emission At Antenna Terminals (+/-1MHz)		
Date of Test	2017/01/06	Test Site	CTR
Test Condition	Block Edge Test (Band 2 (1.4M))		

Band 2 (1.4M) QPSK (1,0) Lower Channel 18607 (1850.7MHz)

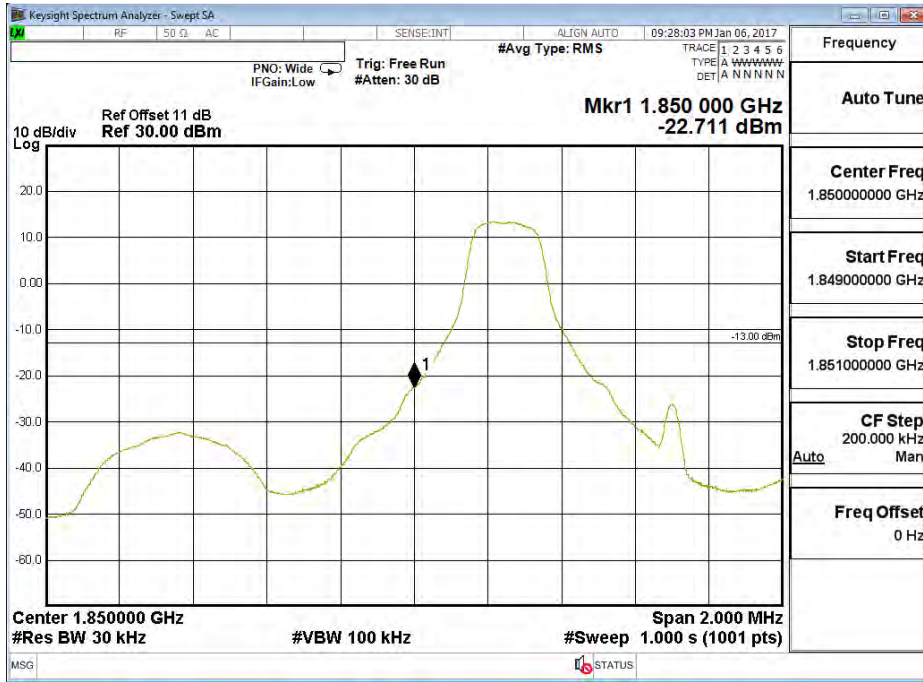

Band 2 (1.4M) QPSK (1,5) Upper Channel 19193 (1909.3MHz)

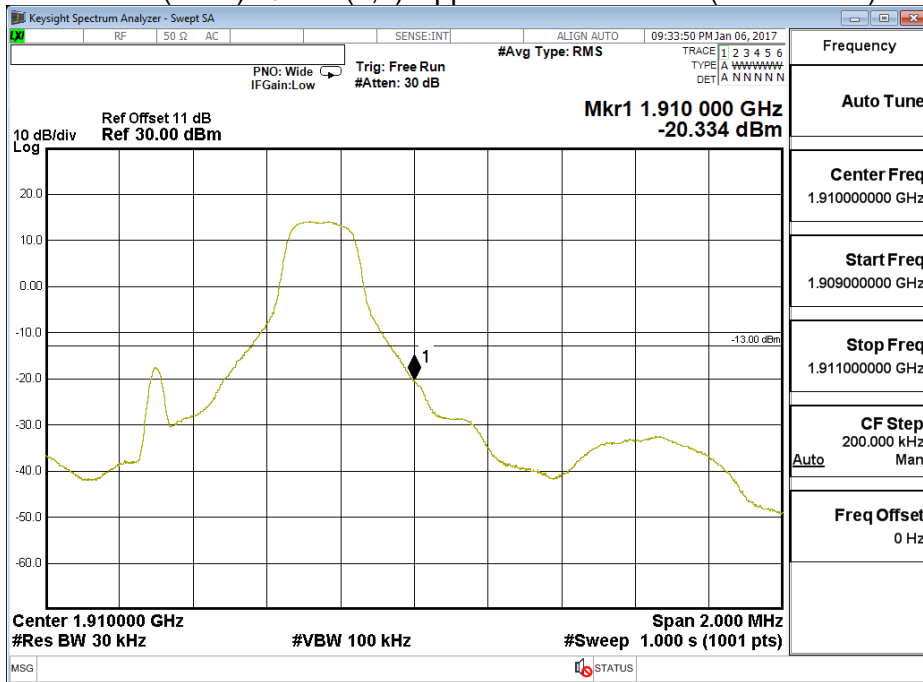

Band 2 (1.4M) QPSK (6,0) Lower Channel 18607 (1850.7MHz)

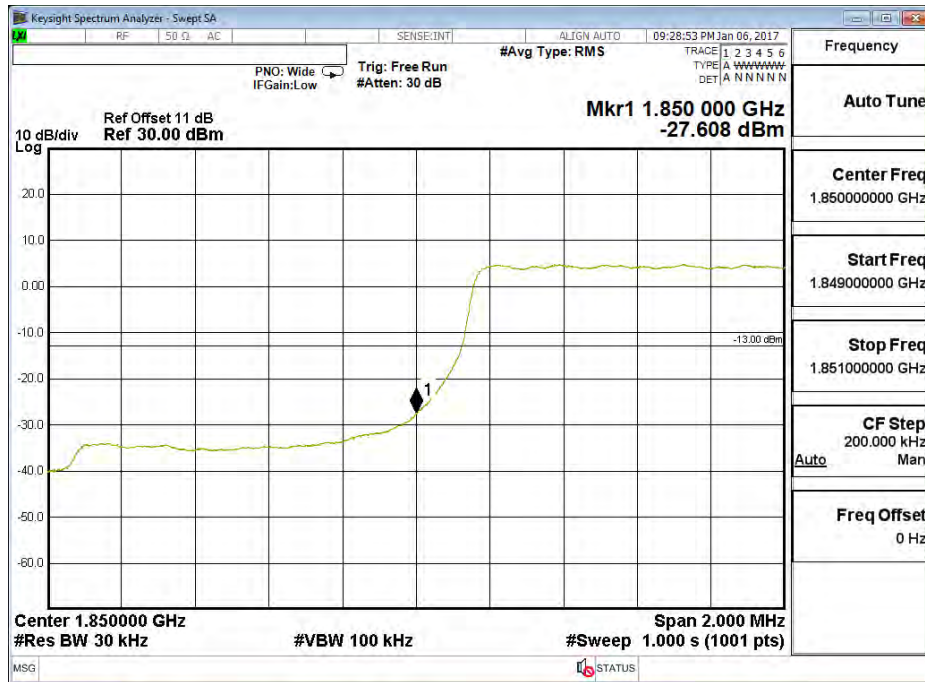

Band 2 (1.4M) QPSK (6,0) Upper Channel 19193 (1909.3MHz)

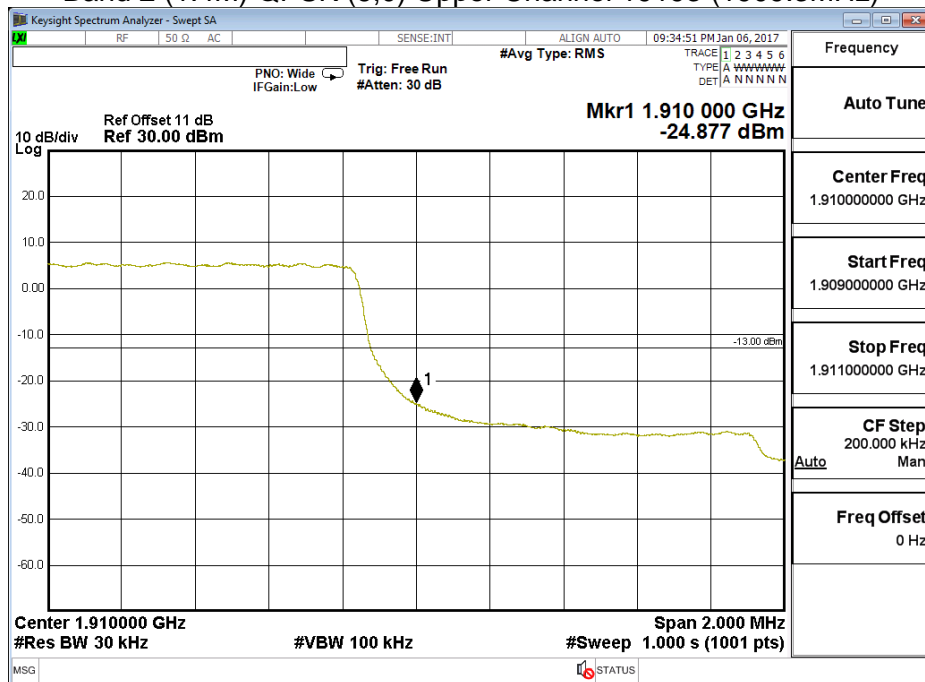

Band 2 (1.4M) 16QAM (1,0) Lower Channel 18607 (1850.7MHz)

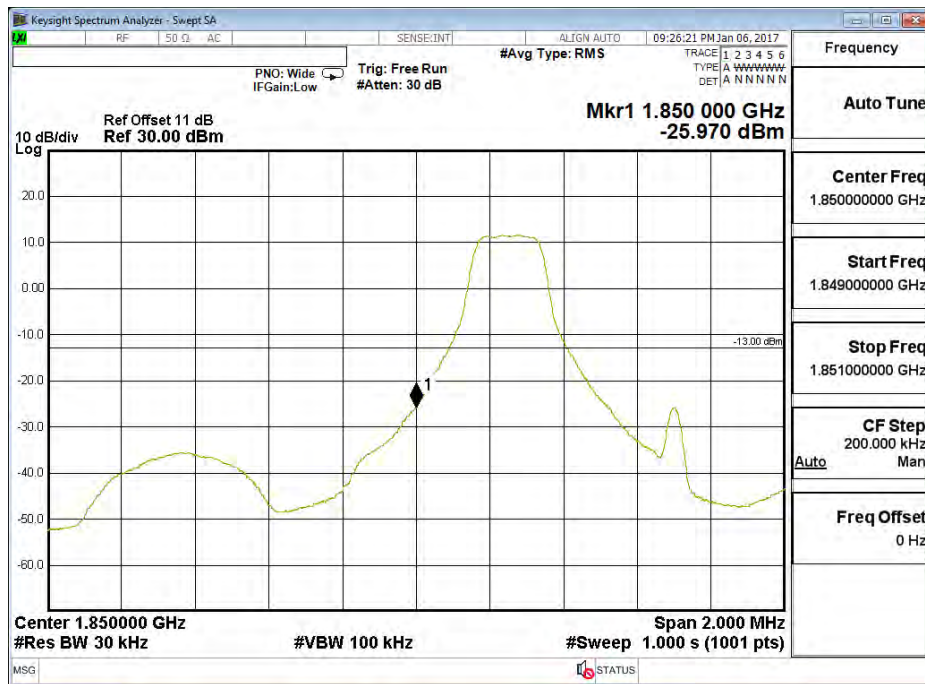

Band 2 (1.4M) 16QAM (1,5) Upper Channel 19193 (1909.3MHz)

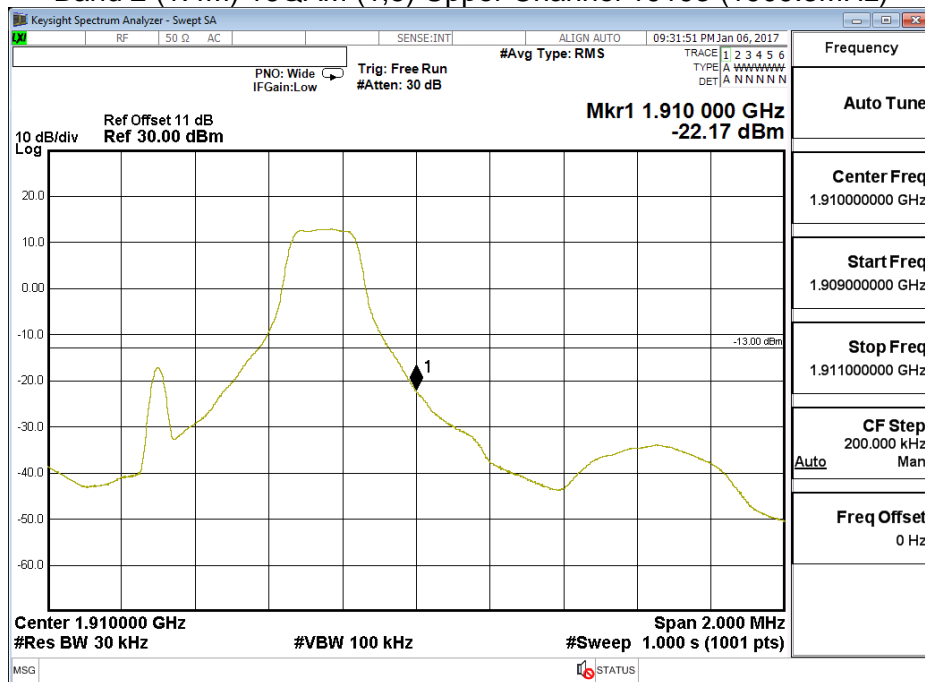

Band 2 (1.4M) 16QAM (6,0) Lower Channel 18607 (1850.7MHz)

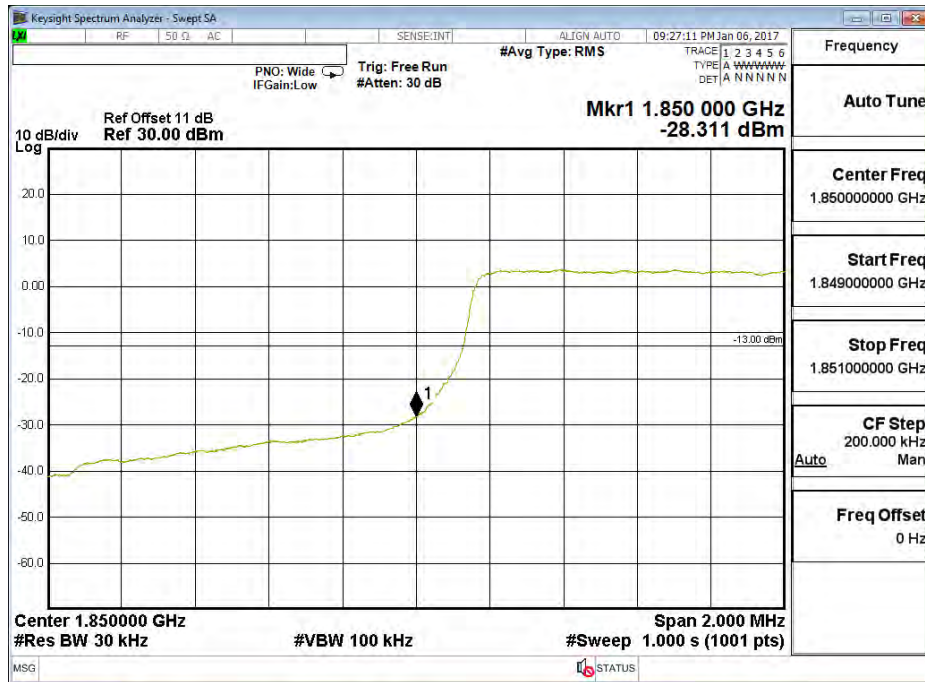

Band 2 (1.4M) 16QAM (6,0) Upper Channel 19193 (1909.3MHz)

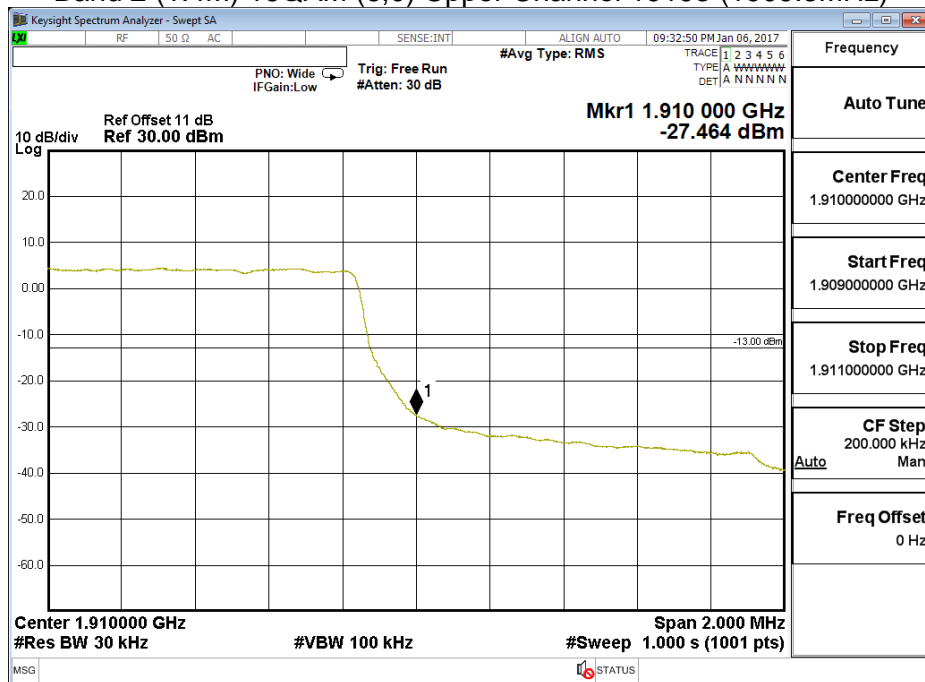

Product	LE910C1-NA		
Test Mode	Spurious Emission At Antenna Terminals (+/-1MHz)		
Date of Test	2017/01/09	Test Site	CTR
Test Condition	Block Edge Test (Band 2 (3M))		

Band 2 (3M) QPSK (1,0) Lower Channel 18615 (1851.5MHz)

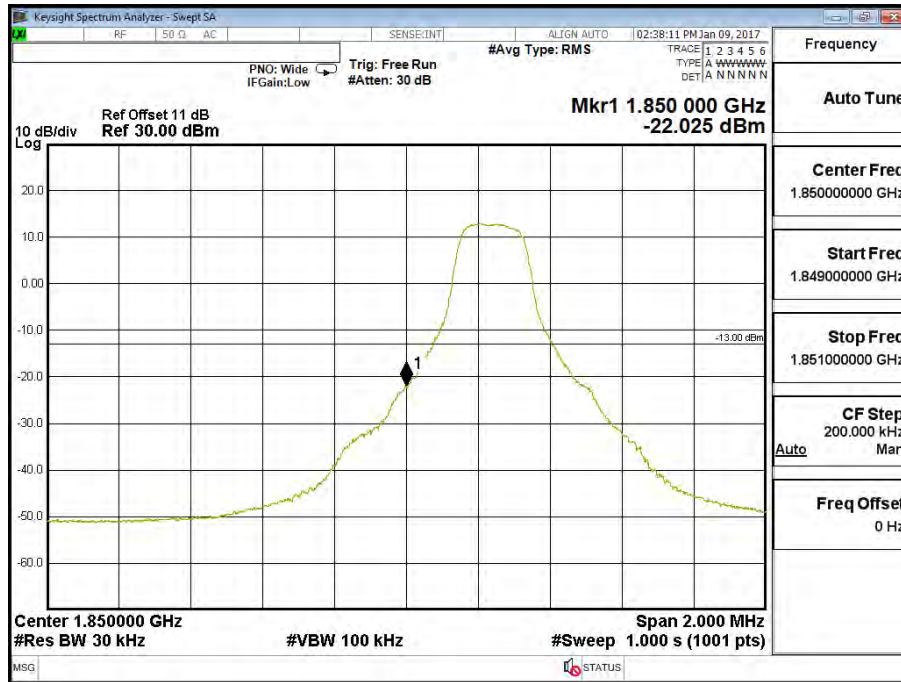

Band 2 (3M) QPSK (1,14) Upper Channel 19185 (1908.5MHz)

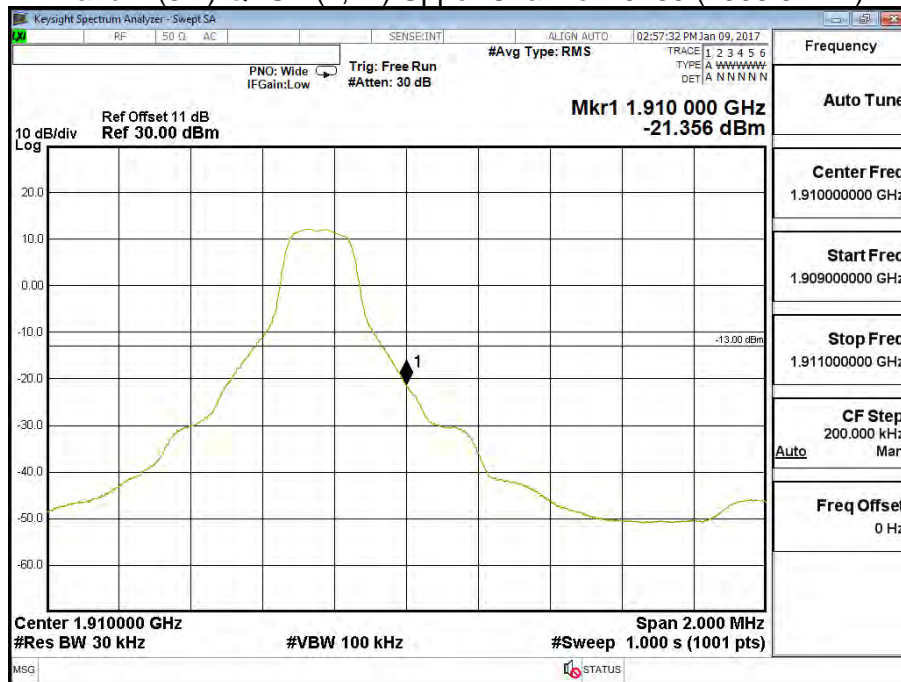

Band 2 (3M) QPSK (15,0) Lower Channel 18615 (1851.5MHz)

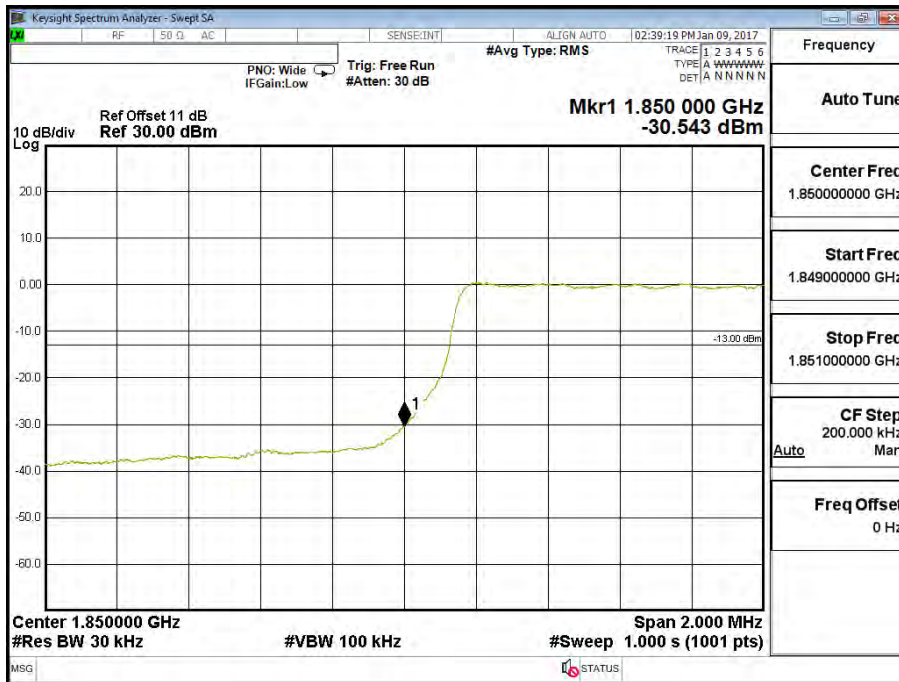

Band 2 (3M) QPSK (15,0) Upper Channel 19185 (1908.5MHz)



Band 2 (3M) 16QAM (1,0) Lower Channel 18615 (1851.5MHz)

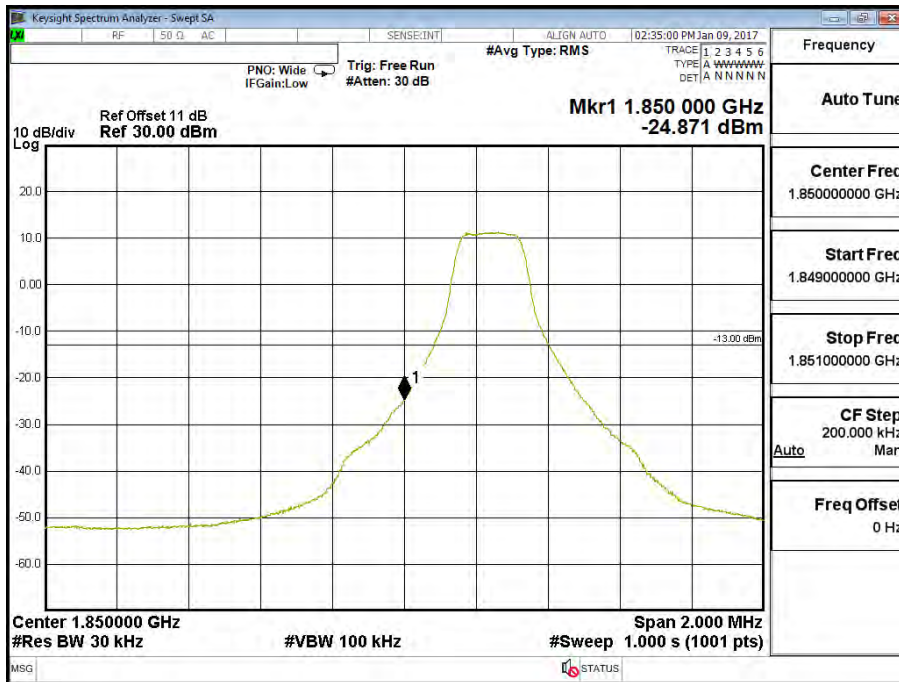

Band 2 (3M) 16QAM (1,14) Upper Channel 19185 (1908.5MHz)

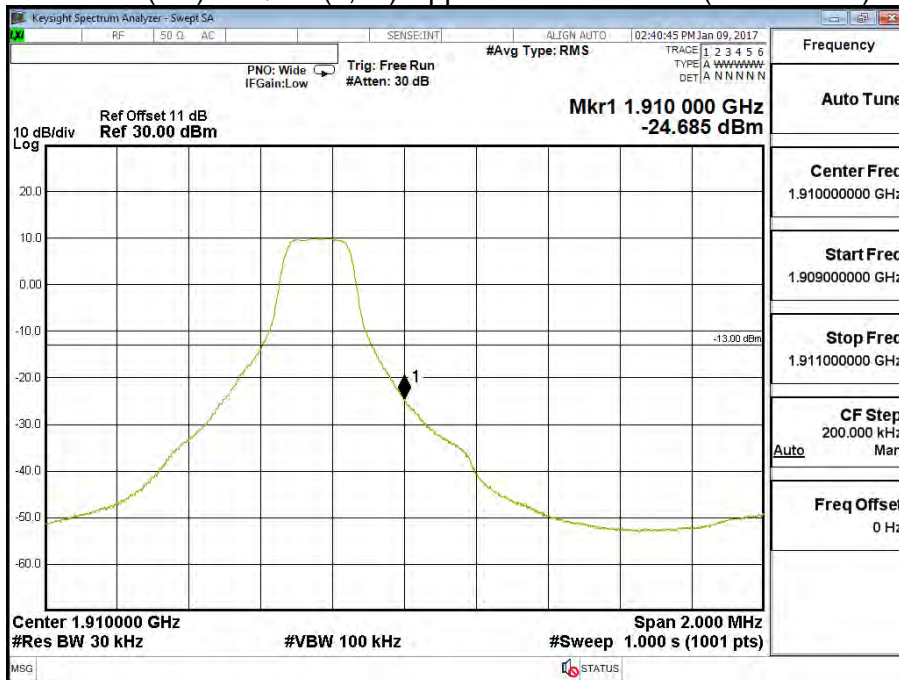

Band 2 (3M) 16QAM (15,0) Lower Channel 18615 (1851.5MHz)

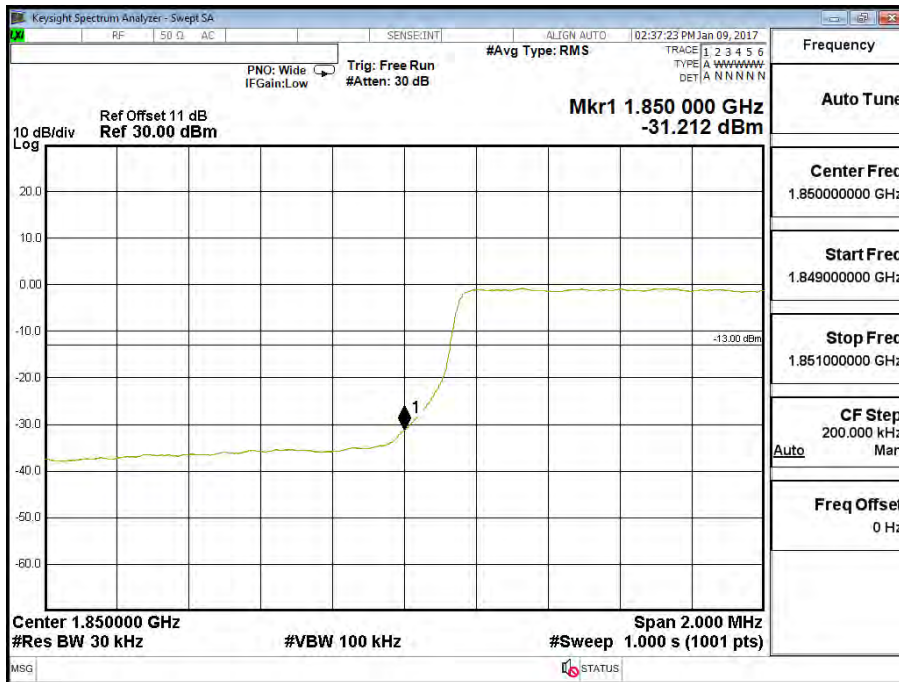

Band 2 (3M) 16QAM (15,0) Upper Channel 19185 (1908.5MHz)





Product	LE910C1-NA		
Test Mode	Spurious Emission At Antenna Terminals (+/-1MHz)		
Date of Test	2017/01/09	Test Site	CTR
Test Condition	Block Edge Test (Band 2 (5M))		

Band 2 (5M) QPSK(1,0) Lower Channel 18625 (1852.5MHz)

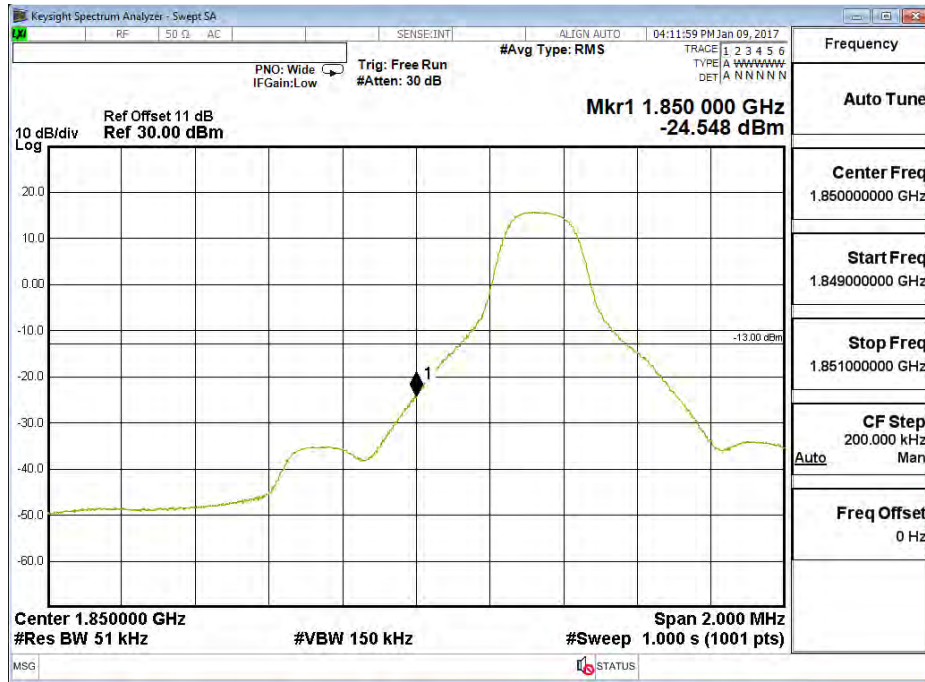

Band 2 (5M) QPSK(1,24) Upper Channel 19175 (1907.5MHz)

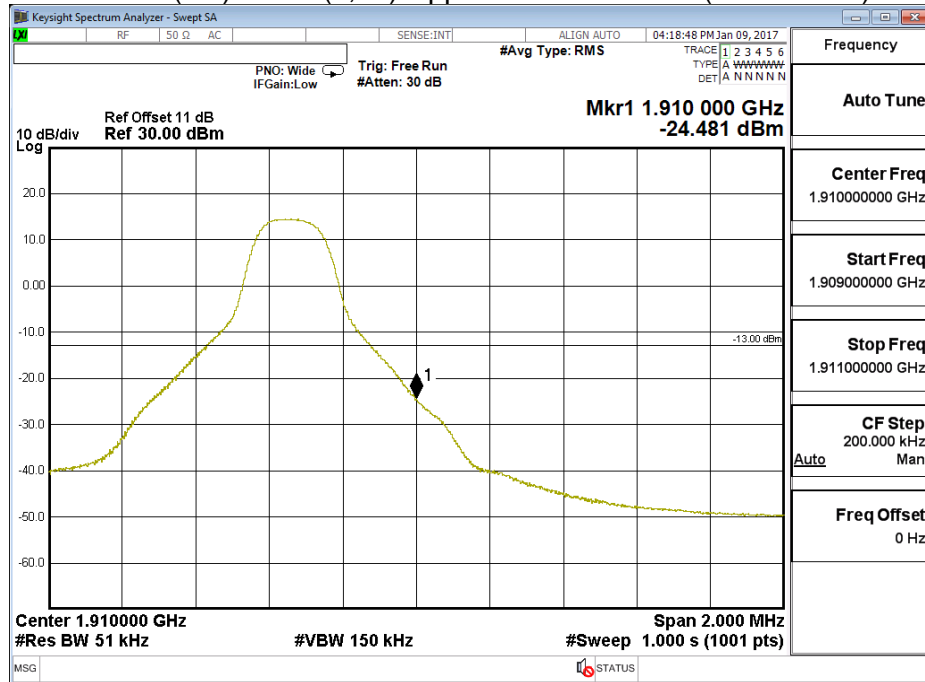

Band 2 (5M) QPSK(25,0) Lower Channel 18625 (1852.5MHz)

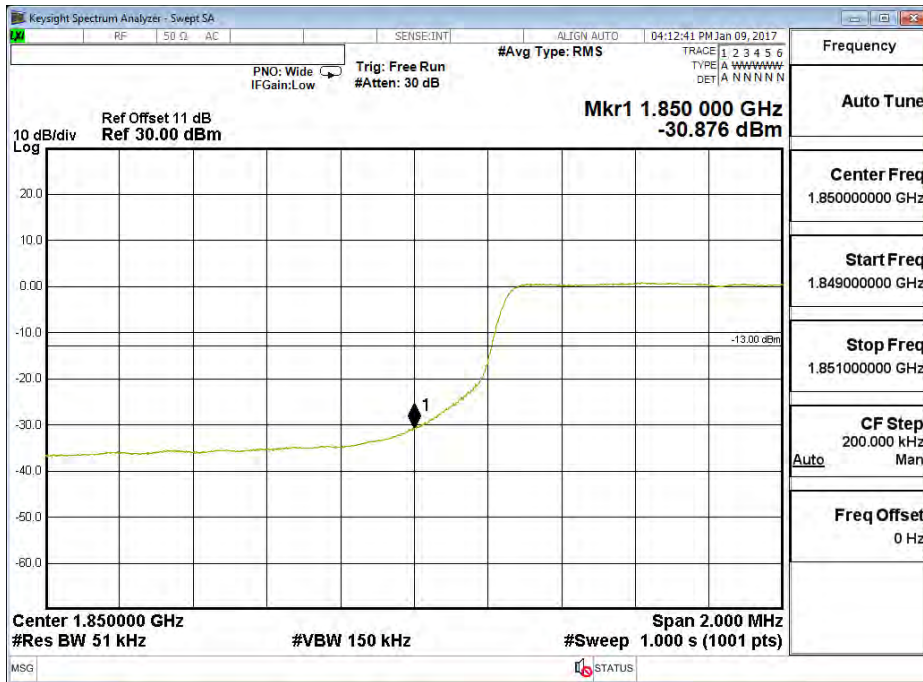

Band 2 (5M) QPSK(25,0) Upper Channel 19175 (1907.5MHz)

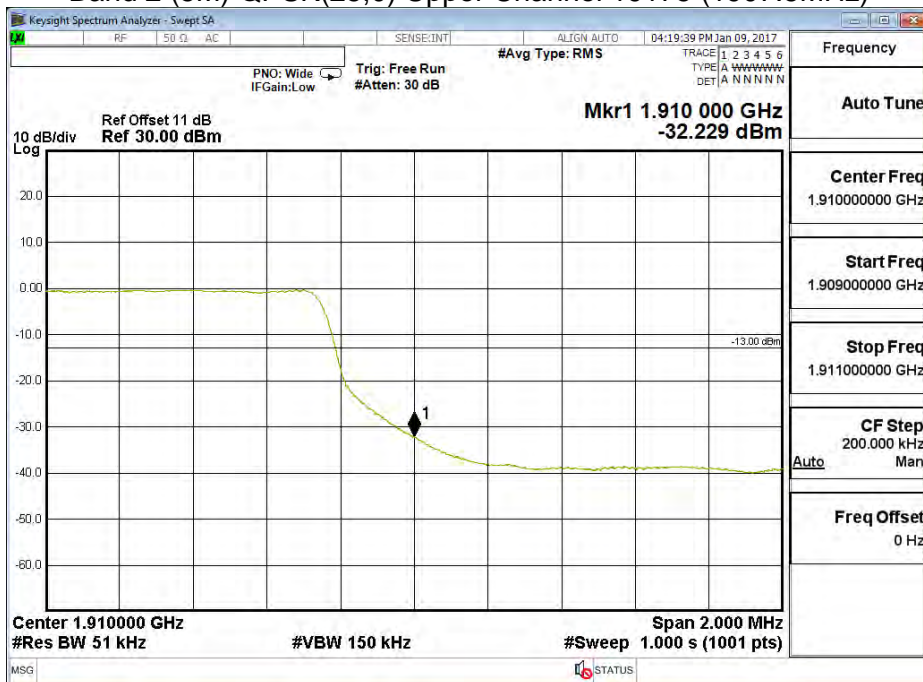

Band 2 (5M) 16QAM(1,0) Lower Channel 18625 (1852.5MHz)

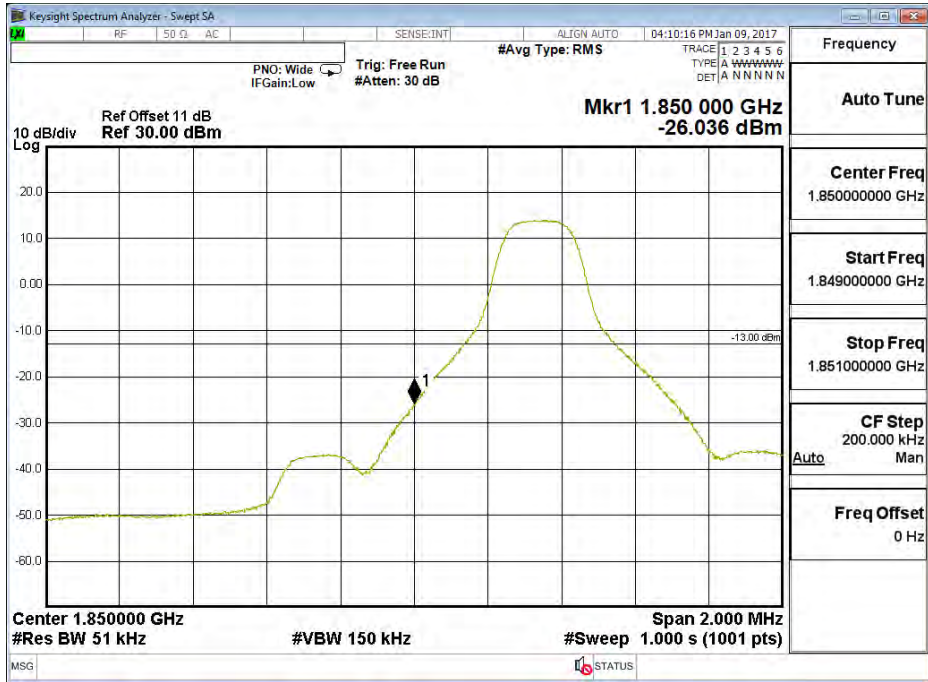

Band 2 (5M) 16QAM(1,24) Upper Channel 19175 (1907.5MHz)

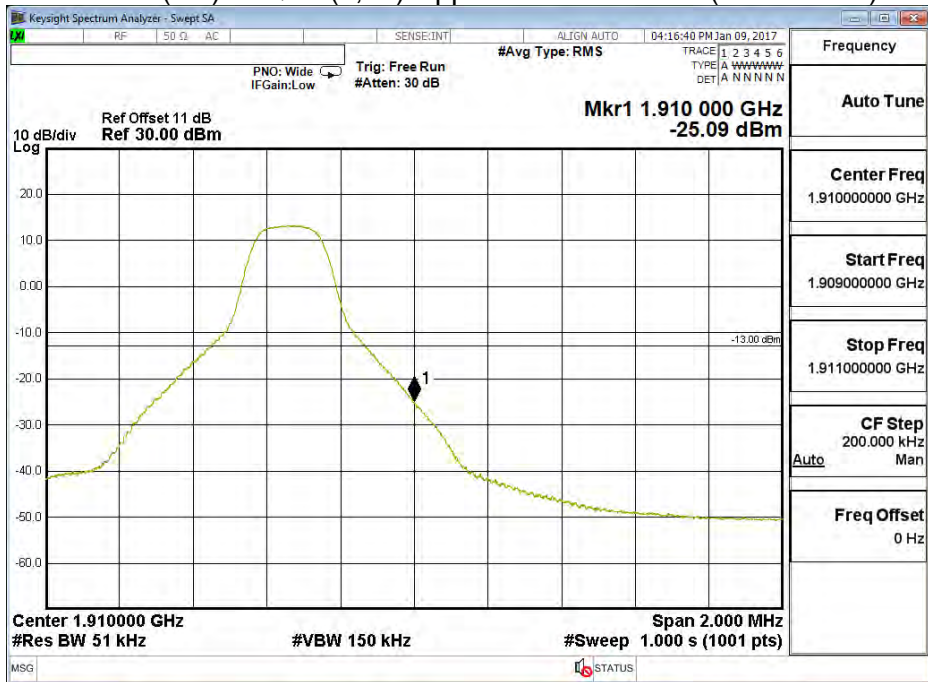

Band 2 (5M) 16QAM(25,0) Lower Channel 18625 (1852.5MHz)

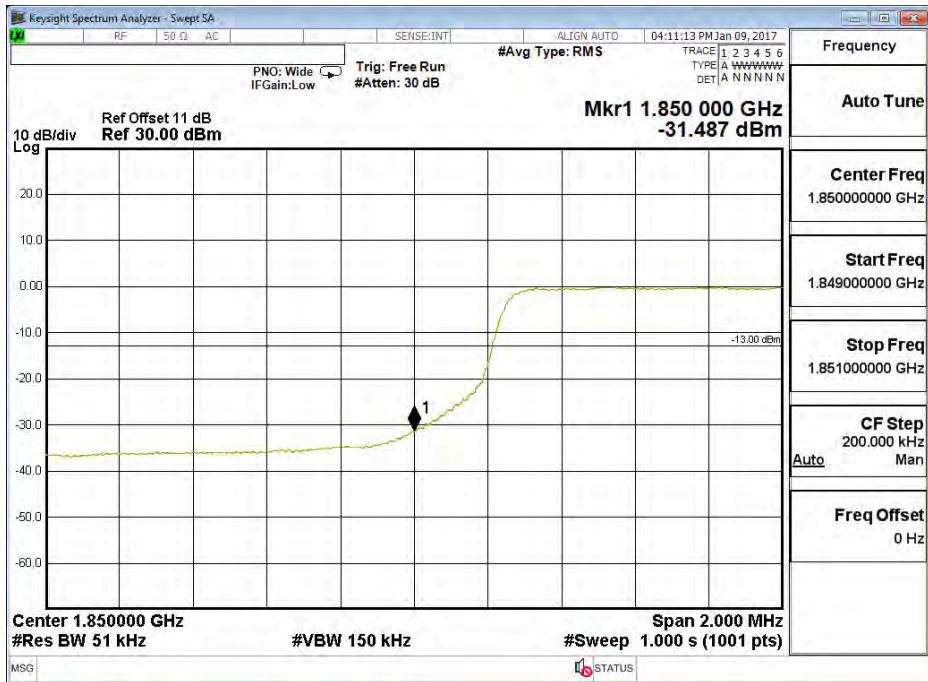

Band 2 (5M) 16QAM(25,0) Upper Channel 19175 (1907.5MHz)

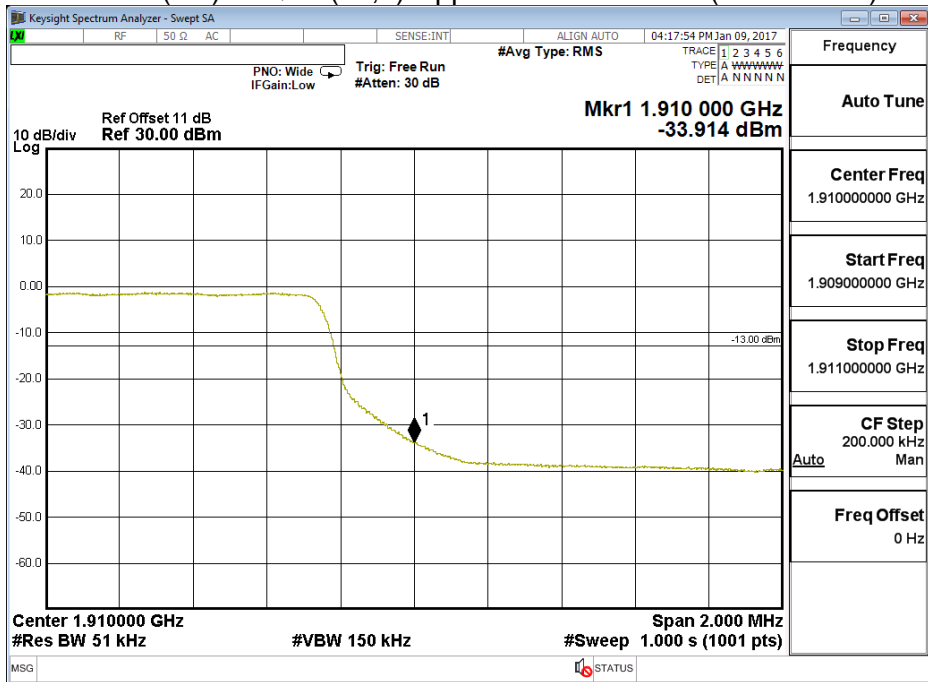

Product	LE910C1-NA		
Test Mode	Spurious Emission At Antenna Terminals (+/-1MHz)		
Date of Test	2017/01/09	Test Site	CTR
Test Condition	Block Edge Test (Band 2 (10M))		

Band 2 (10M) QPSK(1,0) Lower Channel 18650 (1855MHz)

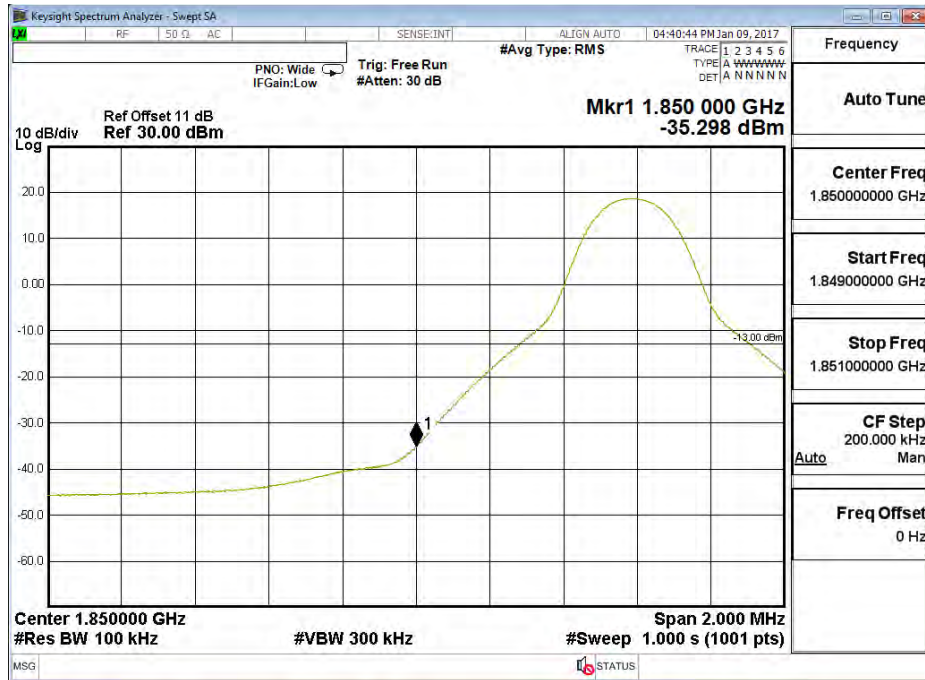

Band 2 (10M) QPSK(1,49) Upper Channel 19150 (1905MHz)

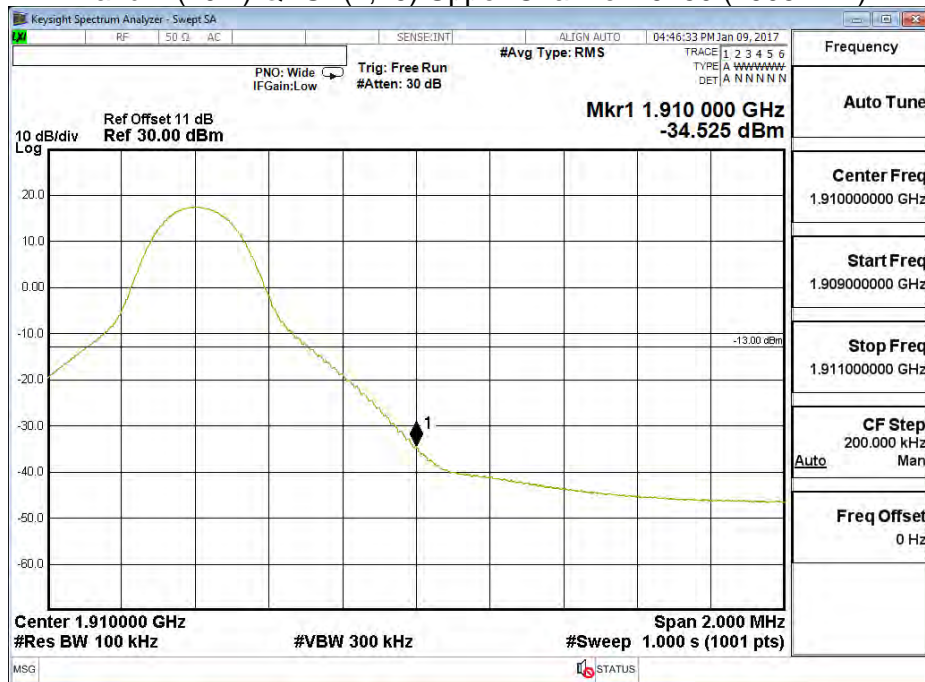

Band 2 (10M) QPSK(50,0) Lower Channel 18650 (1855MHz)

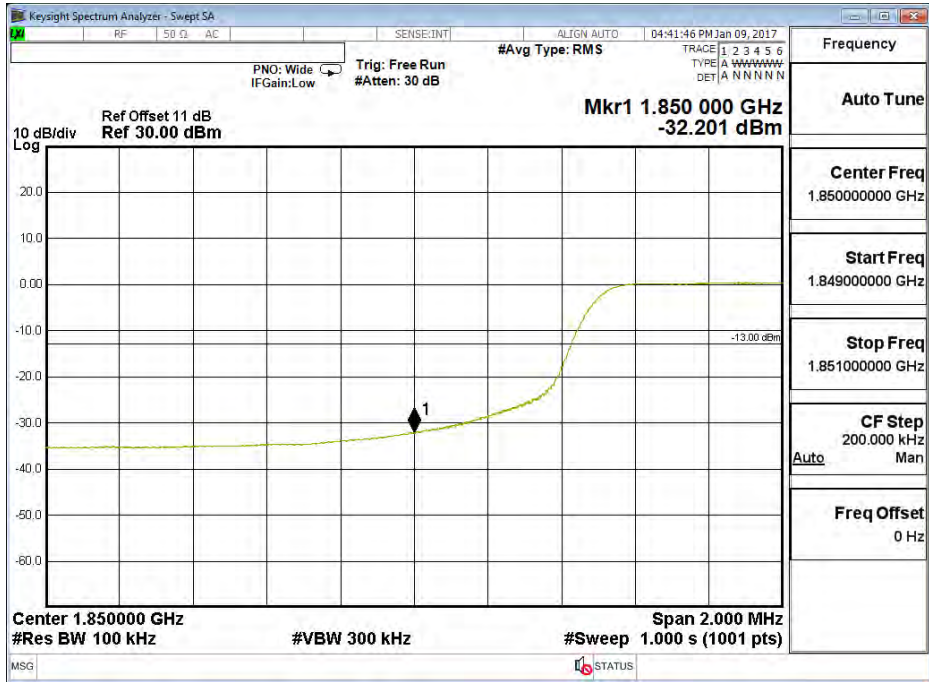

Band 2 (10M) QPSK(50,0) Upper Channel 19150 (1905MHz)

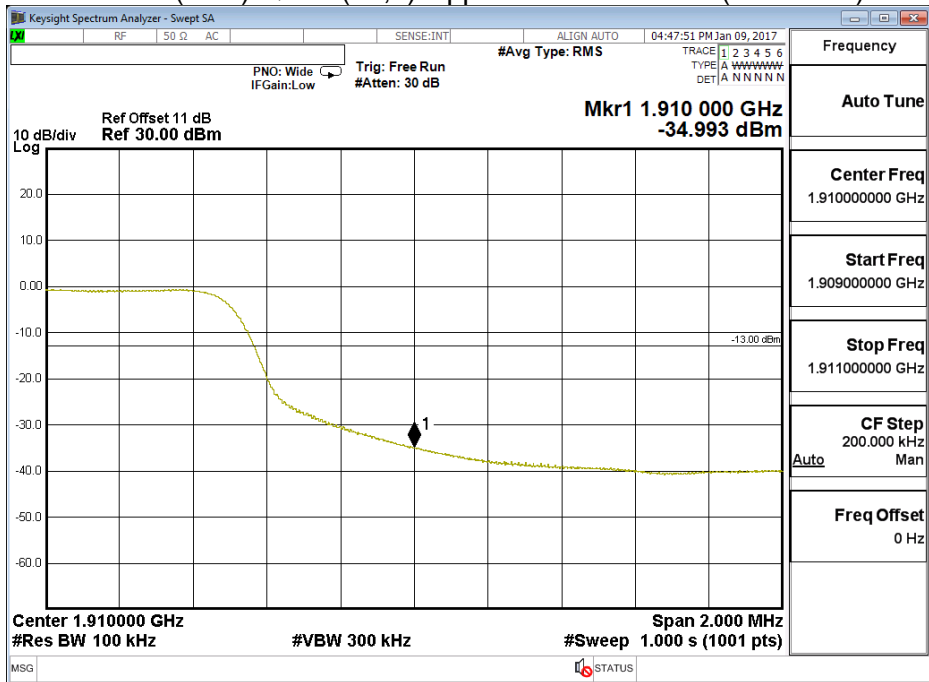

Product	LE910C1-NA		
Test Mode	Spurious Emission At Antenna Terminals (+/-1MHz)		
Date of Test	2017/01/09	Test Site	CTR
Test Condition	Block Edge Test (Band 4 (1.4M))		

Band 4 (1.4M) QPSK (1,0) Lower Channel 19957 (1710.7MHz)

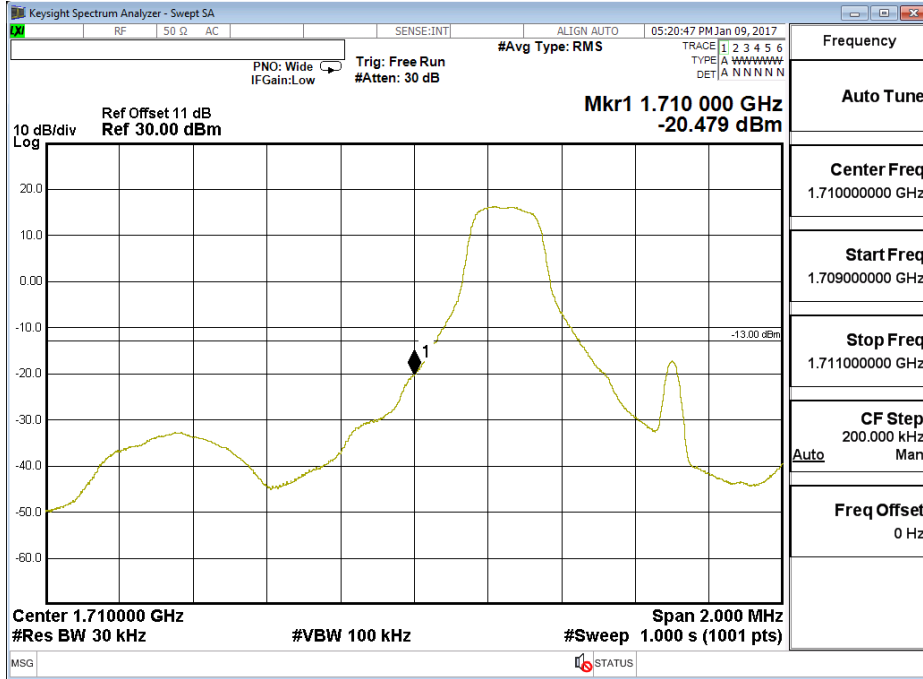

Band 4 (1.4M) QPSK (1,5) Upper Channel 20393 (1754.3MHz)

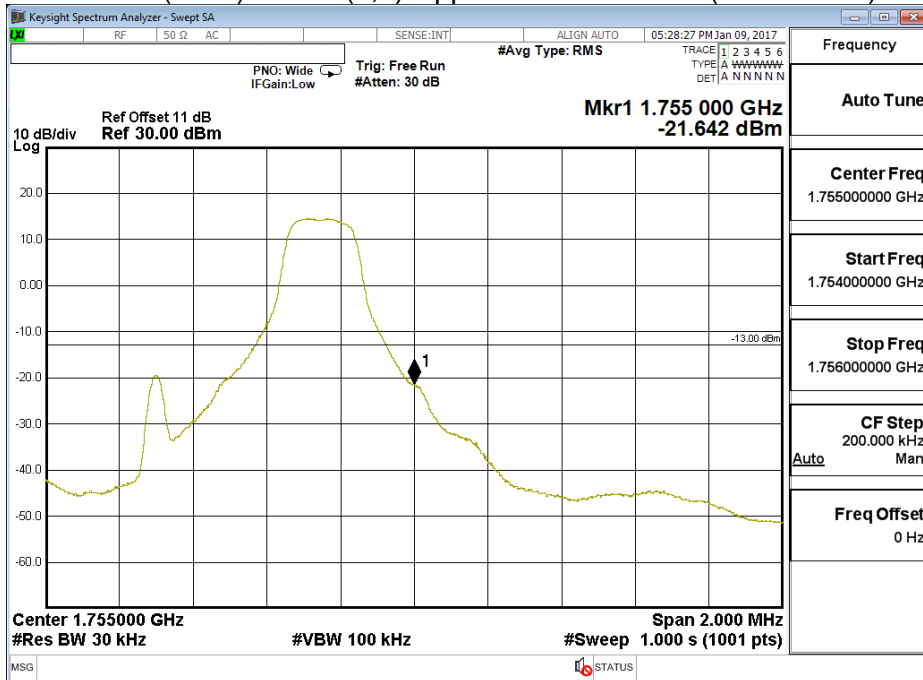

Band 4 (1.4M) QPSK (6,0) Lower Channel 19957 (1710.7MHz)

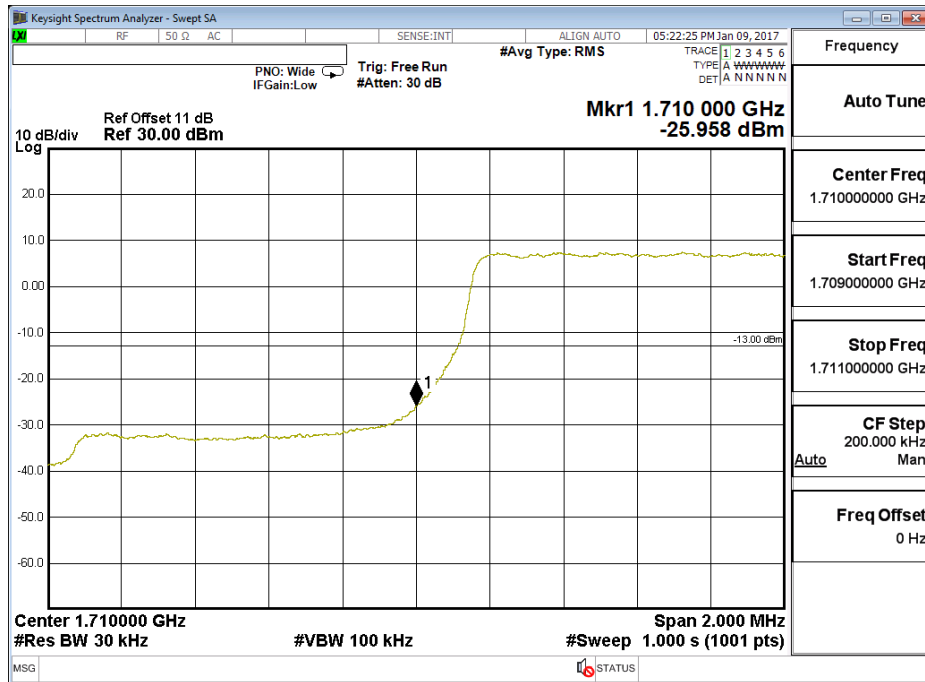

Band 4 (1.4M) QPSK (6,0) Upper Channel 20393 (1754.3MHz)

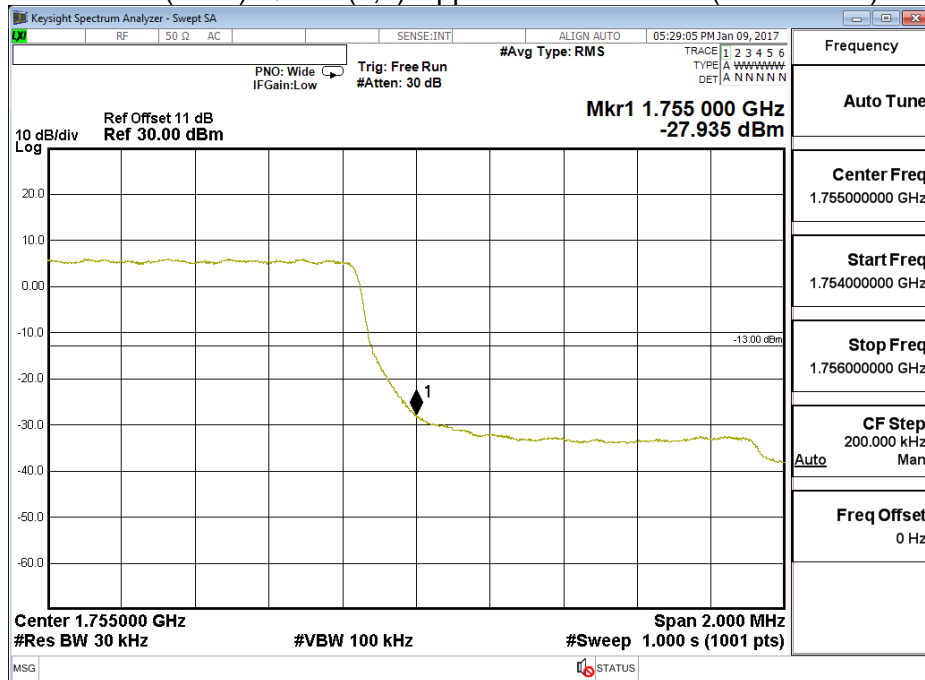



Band 4 (1.4M) 16QAM (1,0) Lower Channel 19957 (1710.7MHz)

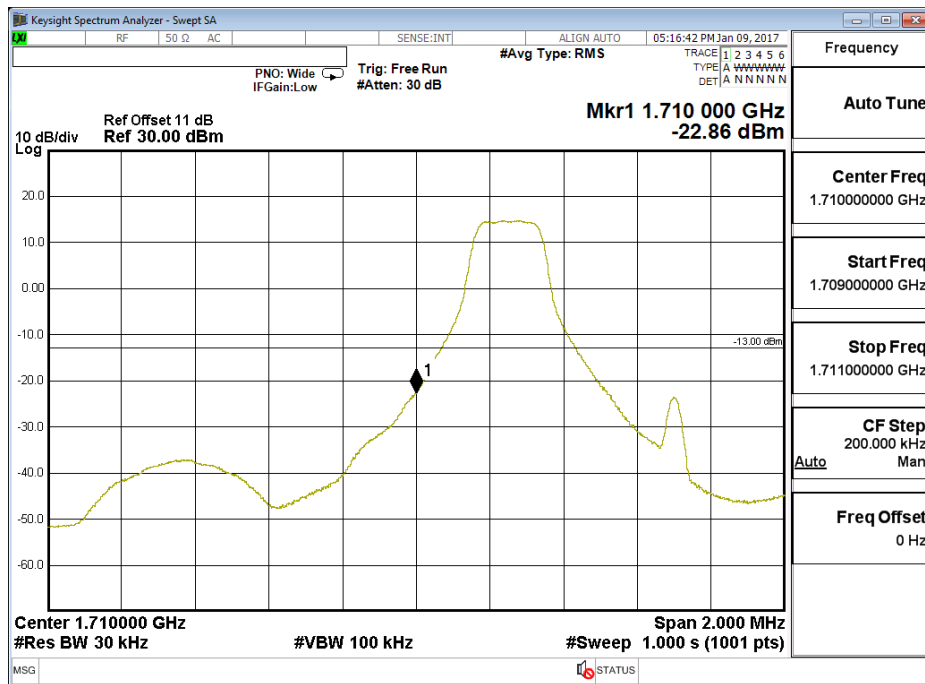

Band 4 (1.4M) 16QAM (1,5) Upper Channel 20393 (1754.3MHz)

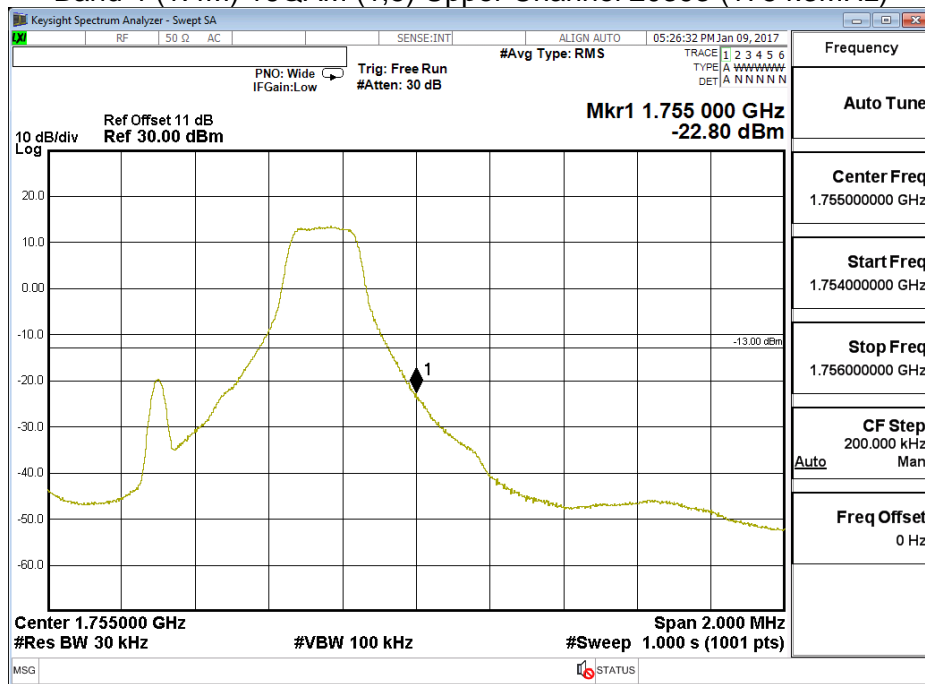

Band 4 (1.4M) 16QAM (6,0) Lower Channel 19957 (1710.7MHz)

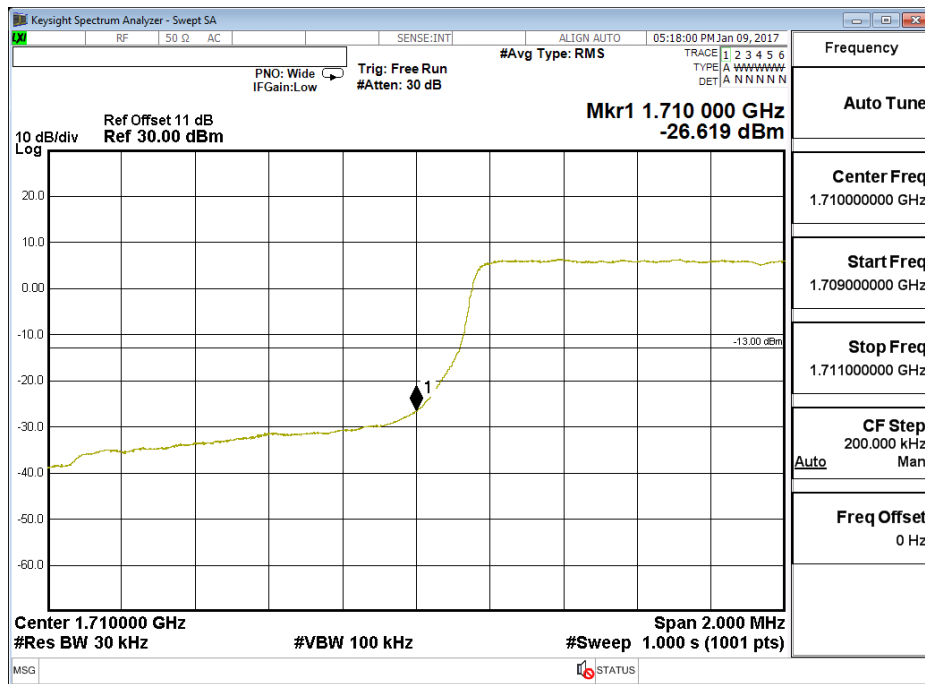

Band 4 (1.4M) 16QAM (6,0) Upper Channel 20393 (1754.3MHz)

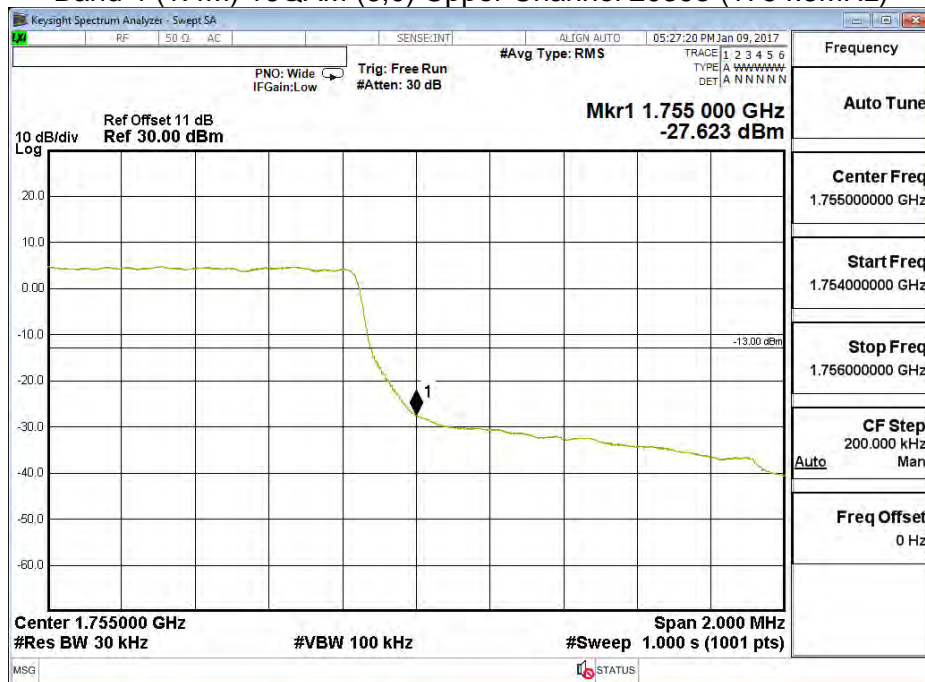

Product	LE910C1-NA		
Test Mode	Spurious Emission At Antenna Terminals (+/-1MHz)		
Date of Test	2017/01/09	Test Site	CTR
Test Condition	Block Edge Test (Band 4 (3M))		

Band 4 (3M) QPSK (1,0) Lower Channel 19965 (1711.5MHz)

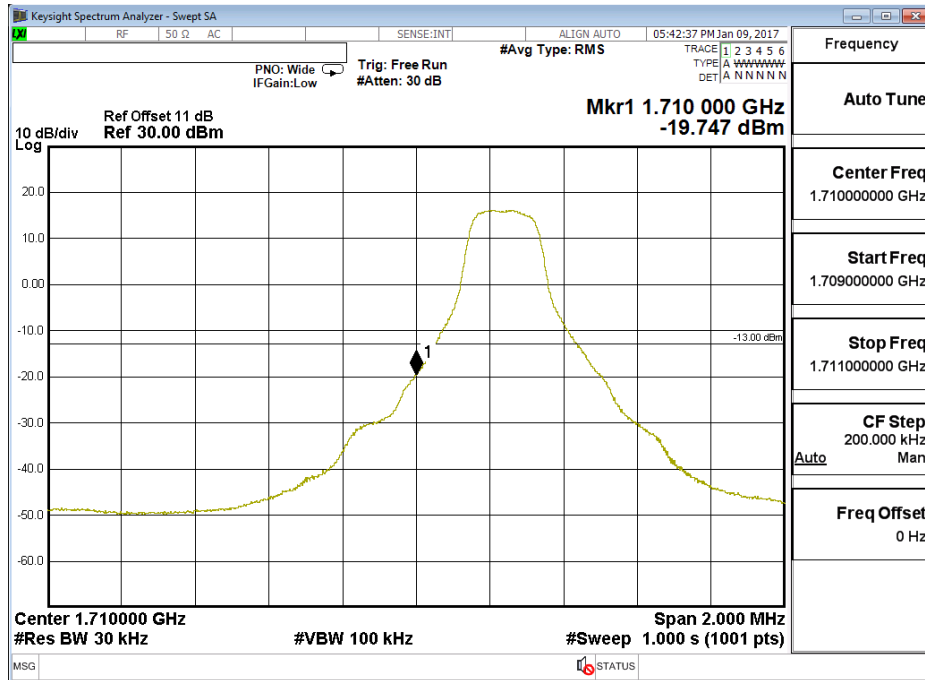

Band 4 (3M) QPSK (1,14) Upper Channel 20385 (1753.5MHz)

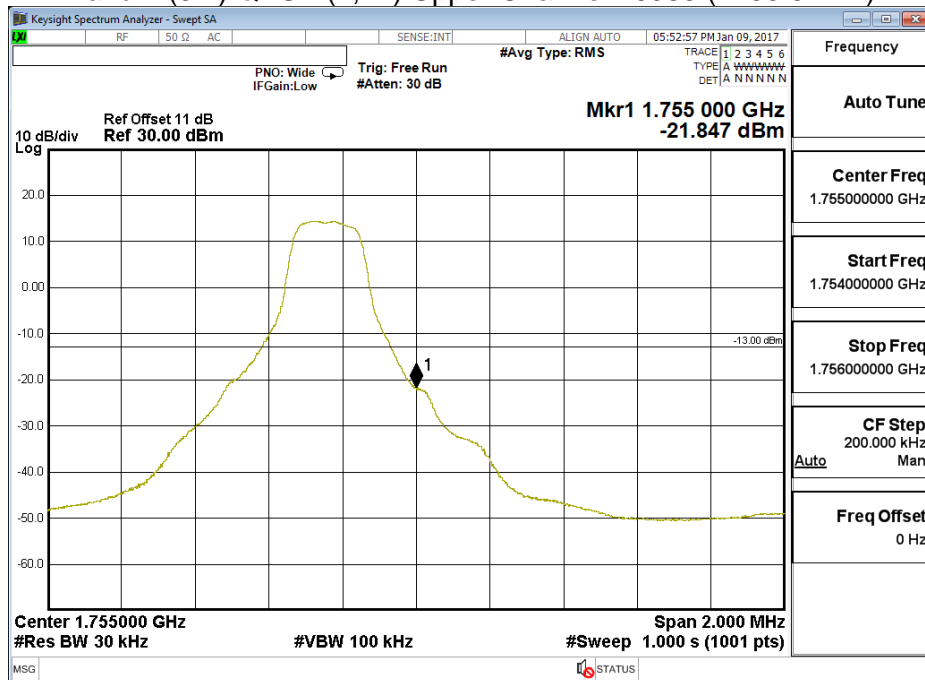

Band 4 (3M) QPSK (15,0) Lower Channel 19965 (1711.5MHz)

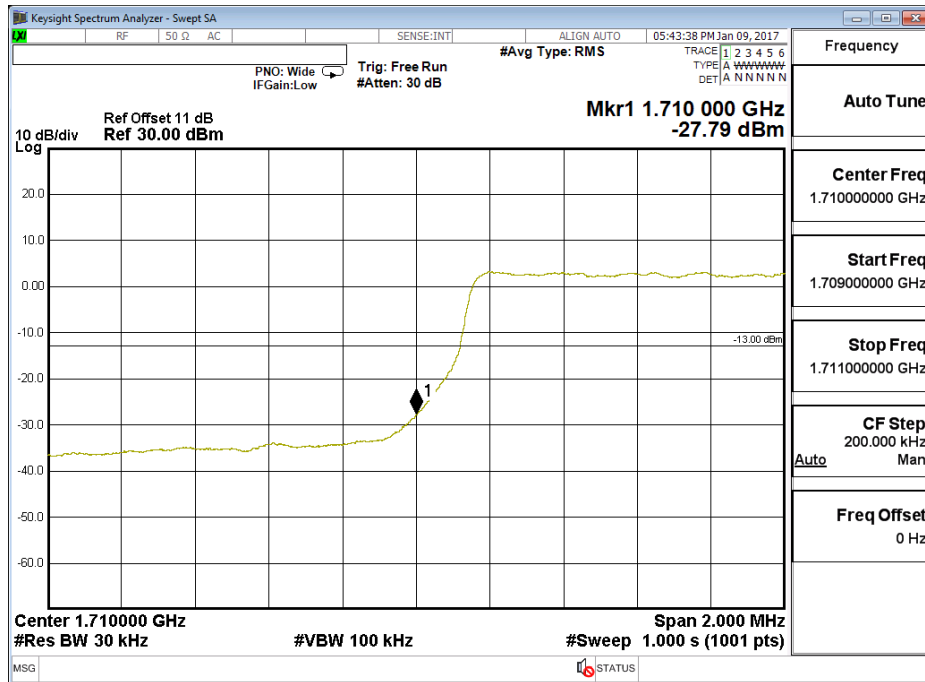

Band 4 (3M) QPSK (15,0) Upper Channel 20385 (1753.5MHz)

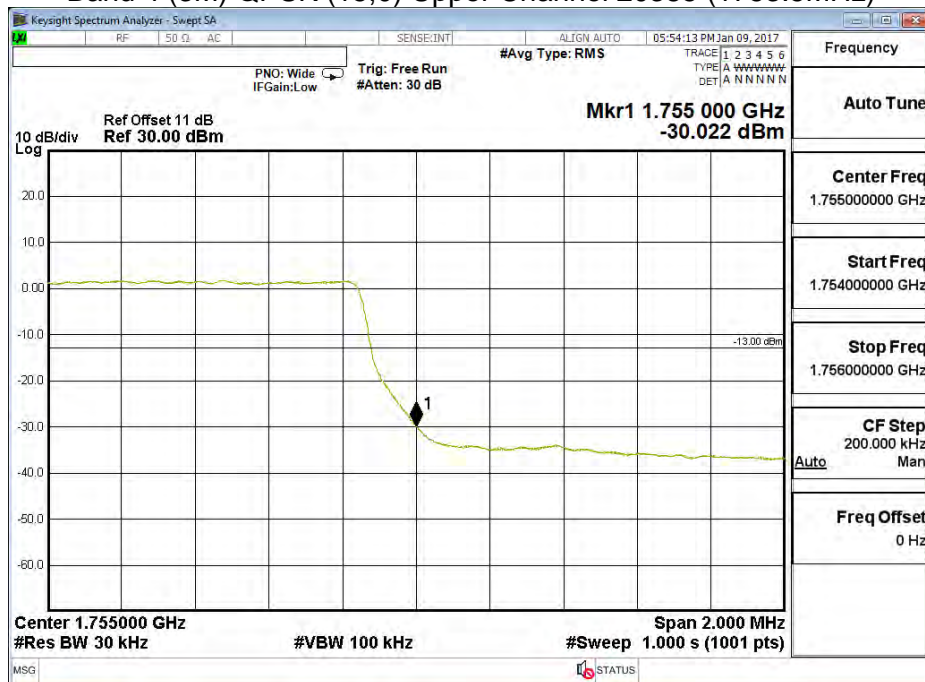

Band 4 (3M) 16QAM (1,0) Lower Channel 19965 (1711.5MHz)

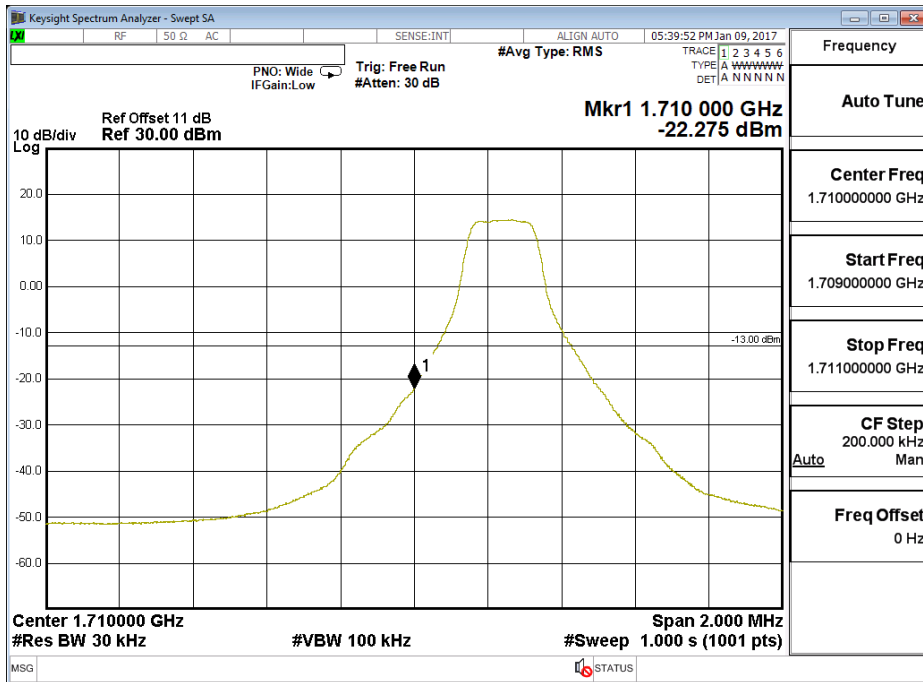

Band 4 (3M) 16QAM (1,14) Upper Channel 20385 (1753.5MHz)

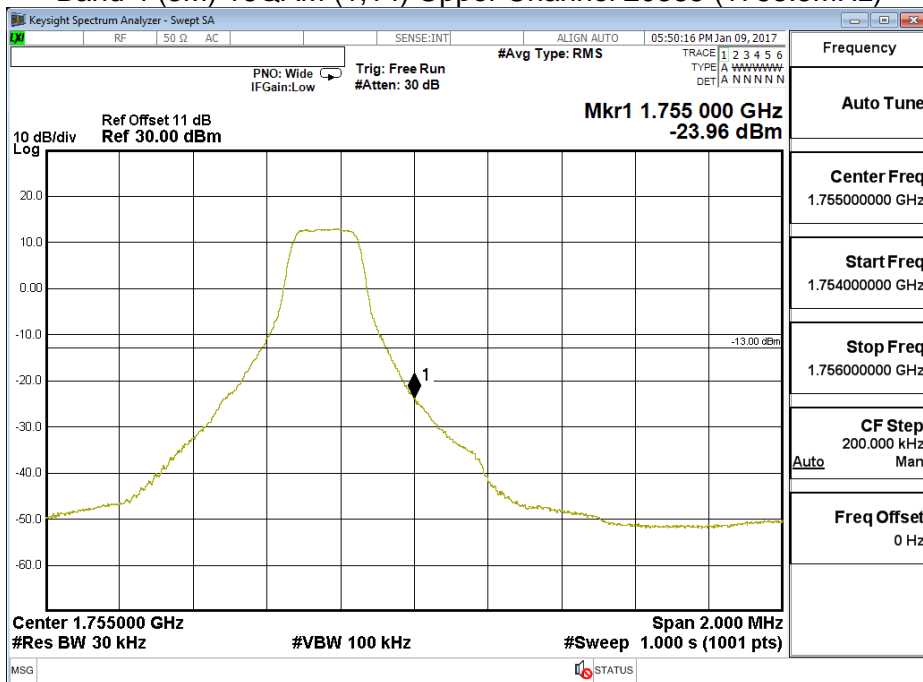

Band 4 (3M) 16QAM (15,0) Lower Channel 19965 (1711.5MHz)

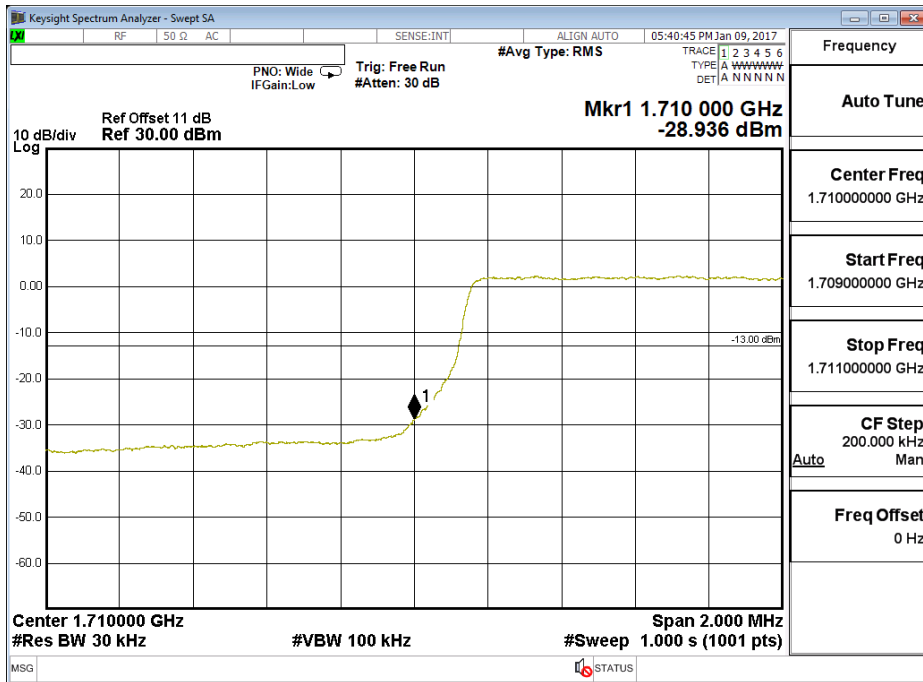

Band 4 (3M) 16QAM (15,0) Upper Channel 20385 (1753.5MHz)

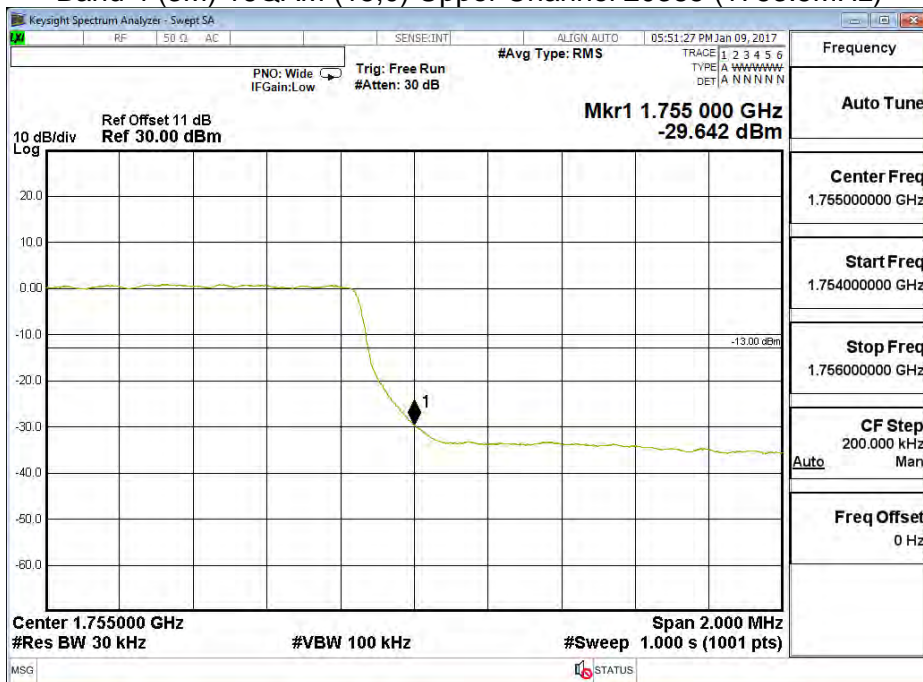

Product	LE910C1-NA		
Test Mode	Spurious Emission At Antenna Terminals (+/-1MHz)		
Date of Test	2017/01/09	Test Site	CTR
Test Condition	Block Edge Test (Band 4 (5M))		

Band 4 (5M) QPSK(1,0) Lower Channel 19975 (1712.5MHz)



Band 4 (5M) QPSK(1,24) Upper Channel 20375 (1752.5MHz)

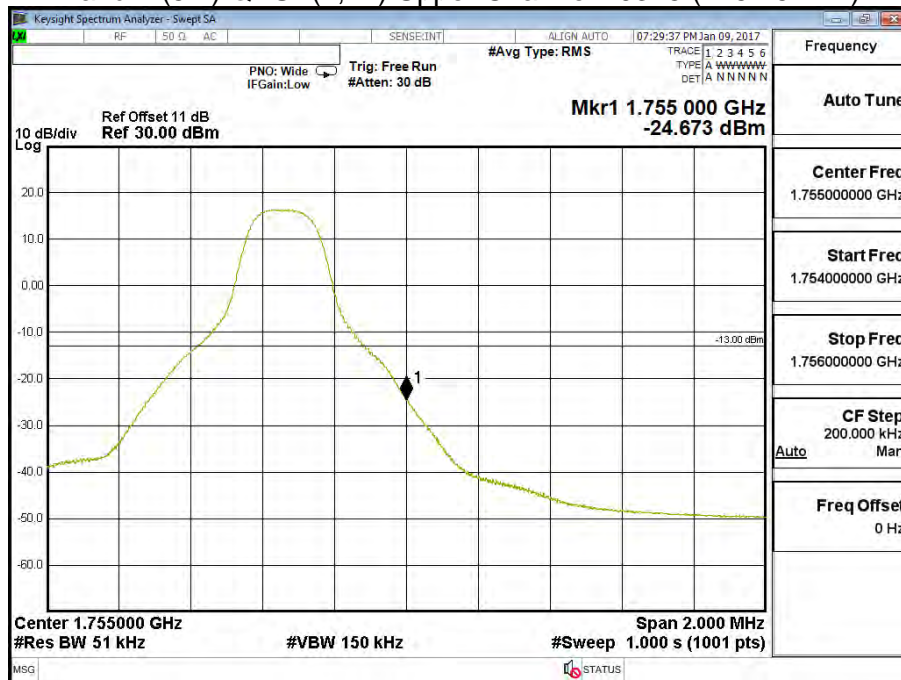

Band 4 (5M) QPSK(25,0) Lower Channel 19975 (1712.5MHz)

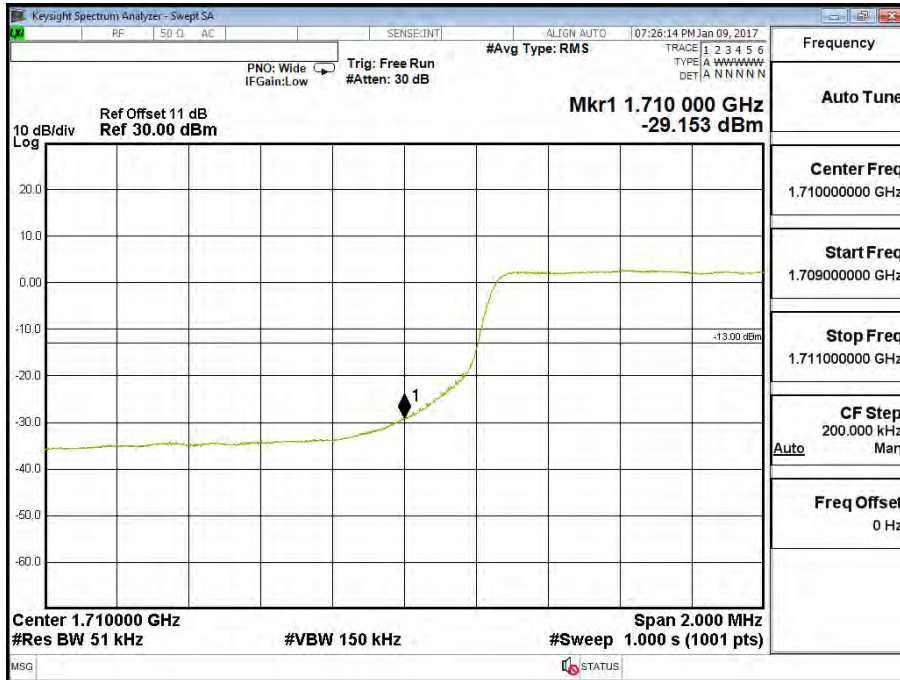

Band 4 (5M) QPSK(25,0) Upper Channel 20375 (1752.5MHz)

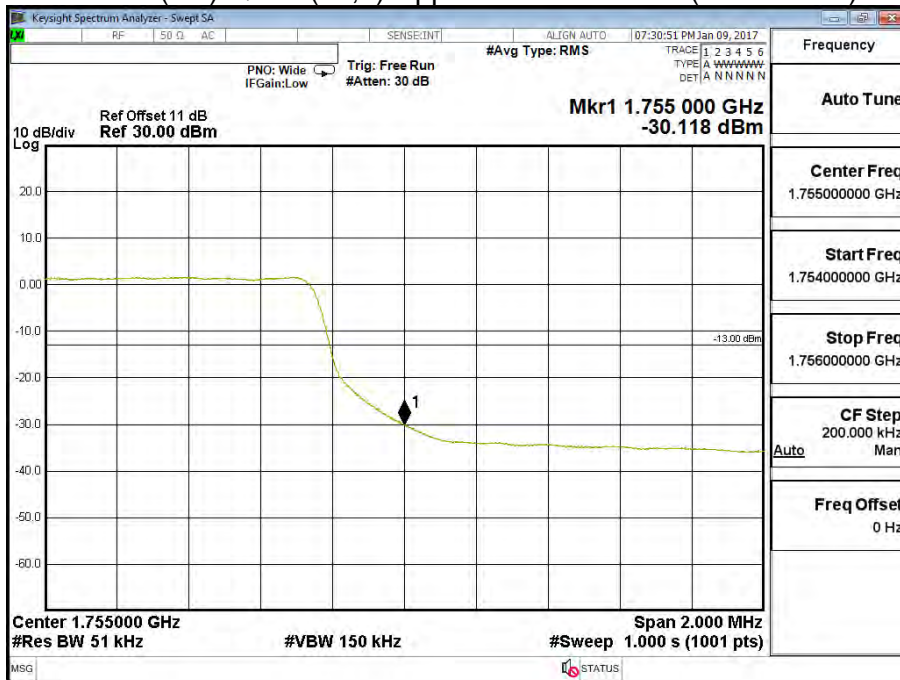



Band 4 (5M) 16QAM(1,0) Lower Channel 19975 (1712.5MHz)



Band 4 (5M) 16QAM(1,24) Upper Channel 20375 (1752.5MHz)

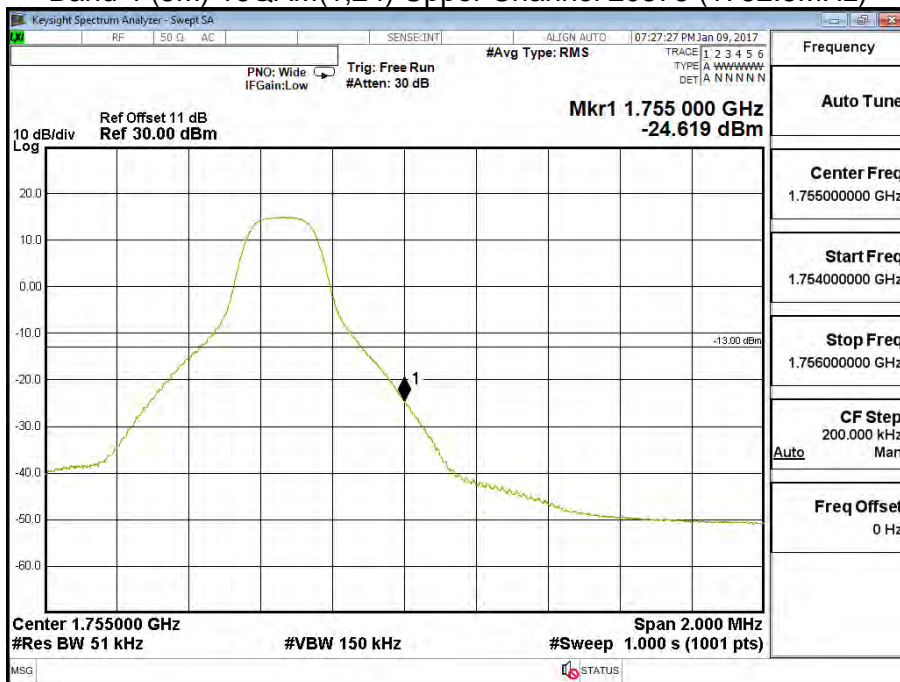

Band 4 (5M) 16QAM(25,0) Lower Channel 19975 (1712.5MHz)

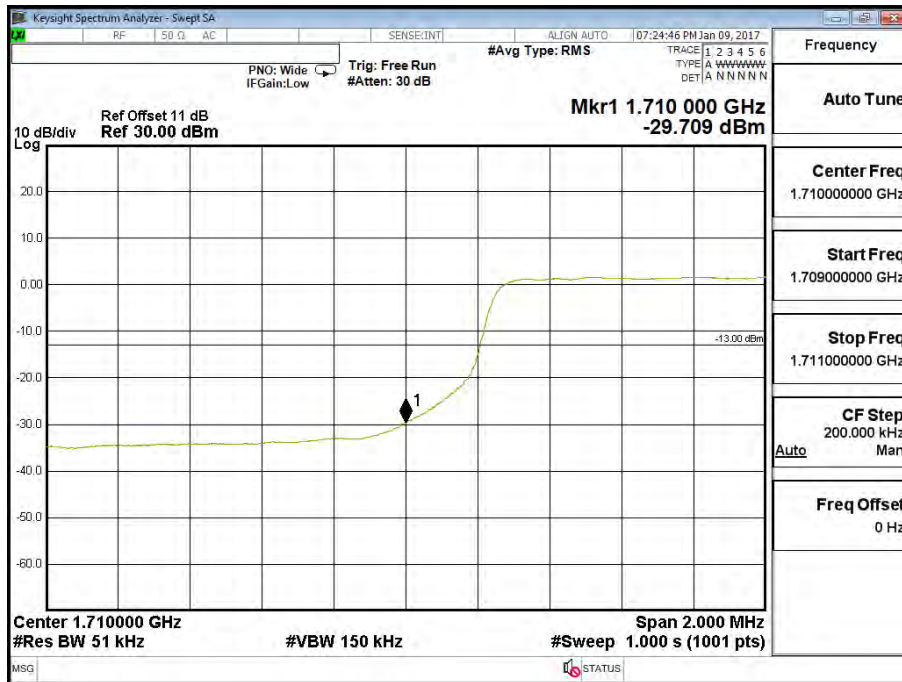

Band 4 (5M) 16QAM(25,0) Upper Channel 20375 (1752.5MHz)

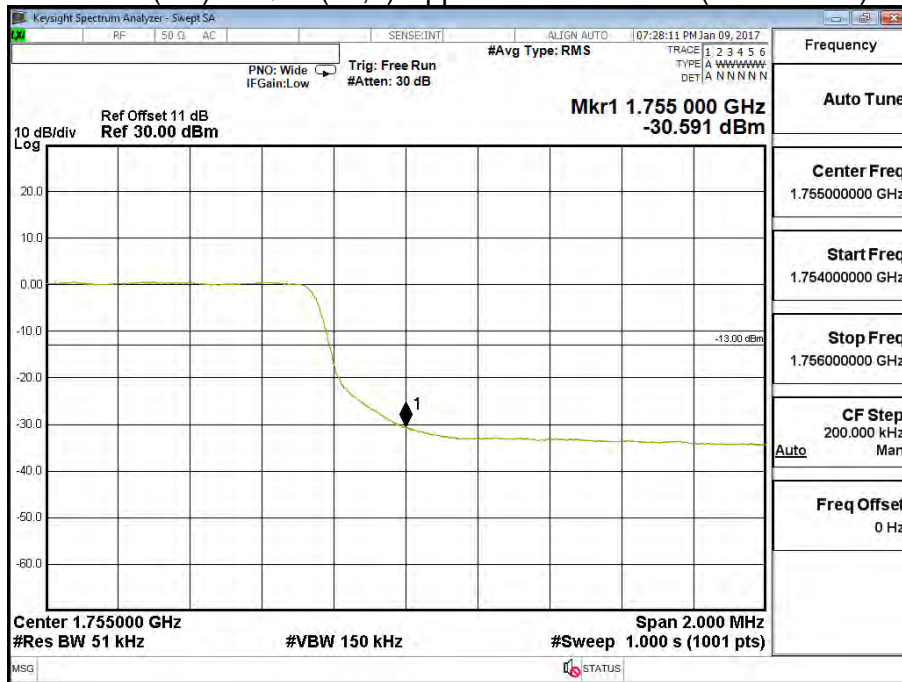

Product	LE910C1-NA		
Test Mode	Spurious Emission At Antenna Terminals (+/-1MHz)		
Date of Test	2017/01/09	Test Site	CTR
Test Condition	Block Edge Test (Band 4 (10M))		

Band 4 (10M) QPSK(1,0) Lower Channel 20000 (1715MHz)

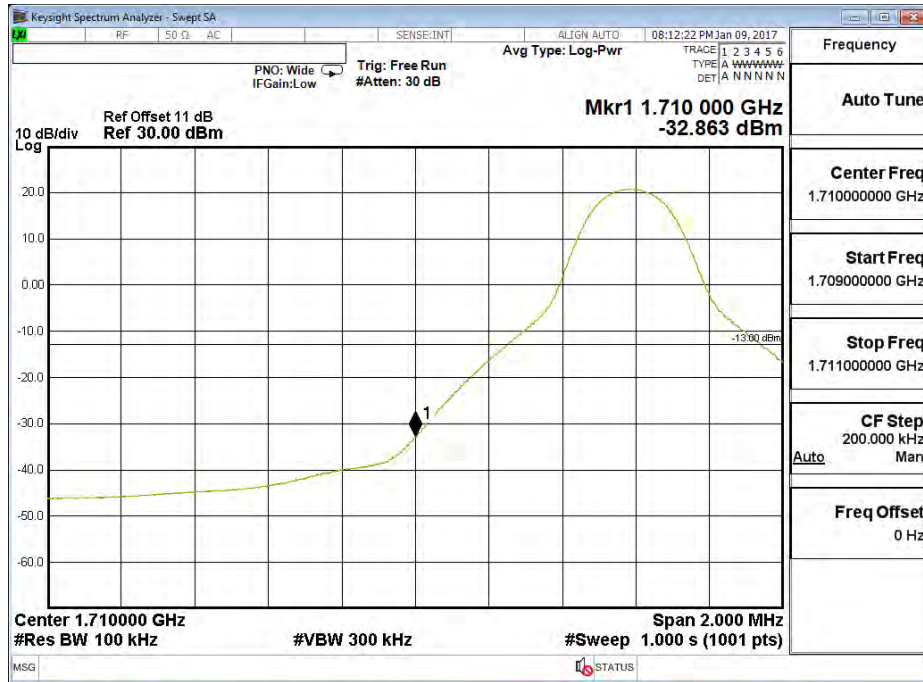

Band 4 (10M) QPSK(1,49) Upper Channel 20350 (1750MHz)

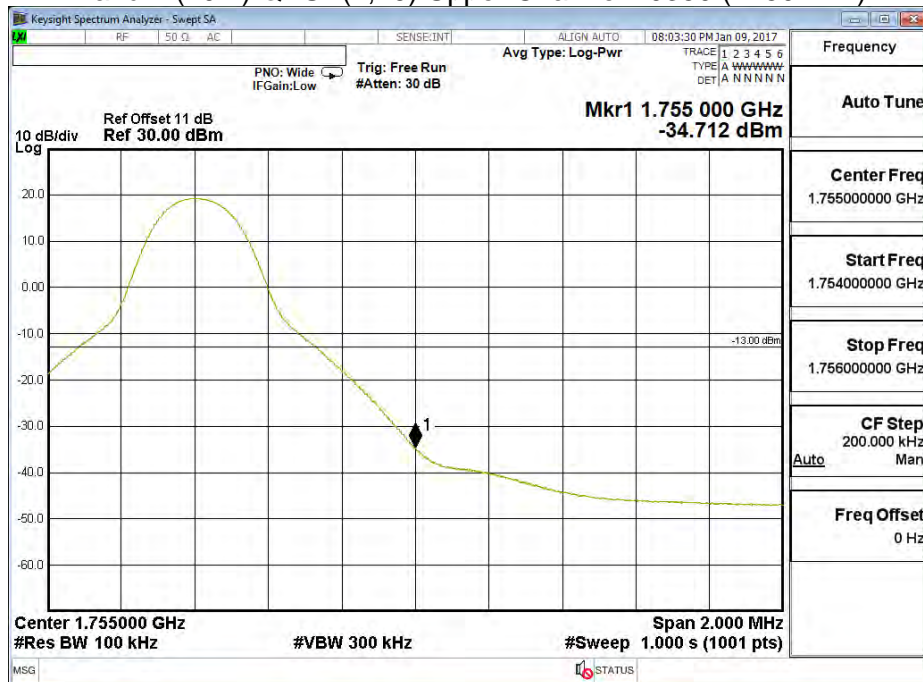

Band 4 (10M) QPSK(50,0) Lower Channel 20000 (1715MHz)

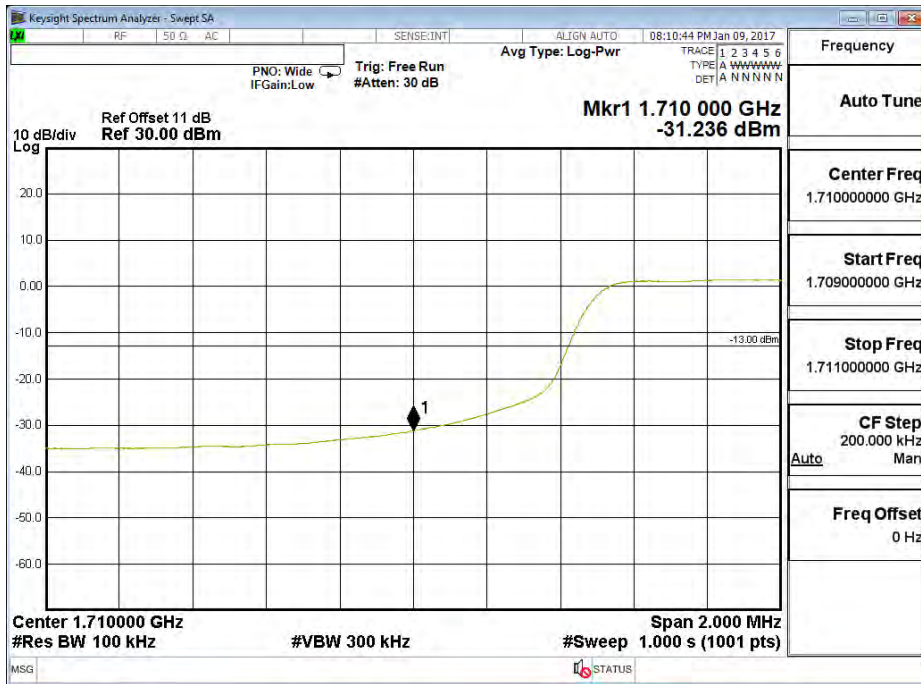

Band 4 (10M) QPSK(50,0) Upper Channel 20350 (1750MHz)

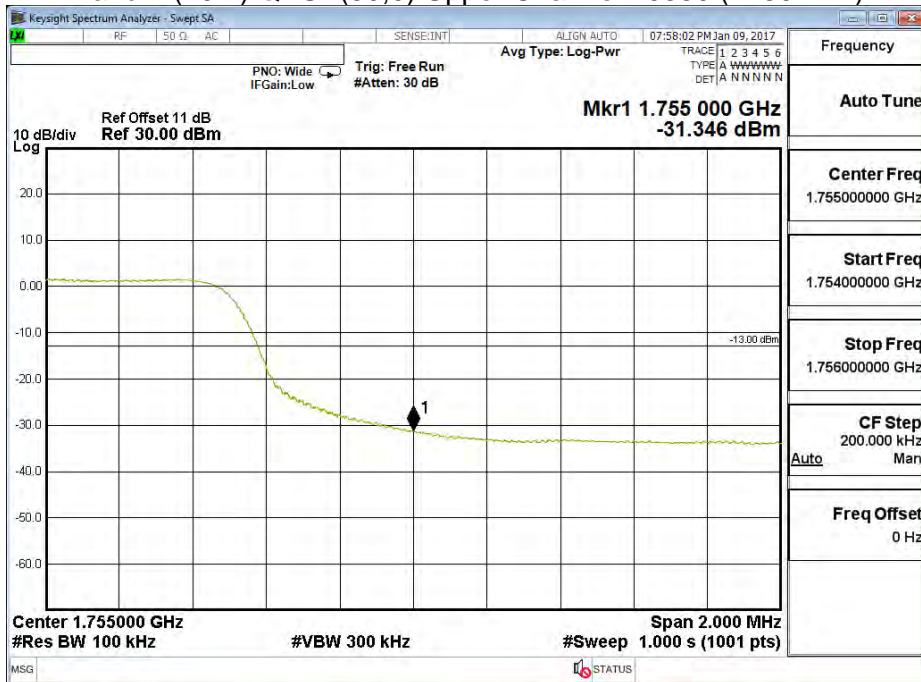

Product	LE910C1-NA		
Test Mode	Spurious Emission At Antenna Terminals (+/-1MHz)		
Date of Test	2017/01/06	Test Site	CTR
Test Condition	Block Edge Test (Band 12 (1.4M))		

Band 12 (1.4M) QPSK(1,0) Lower Channel 23017 (699.7MHz)

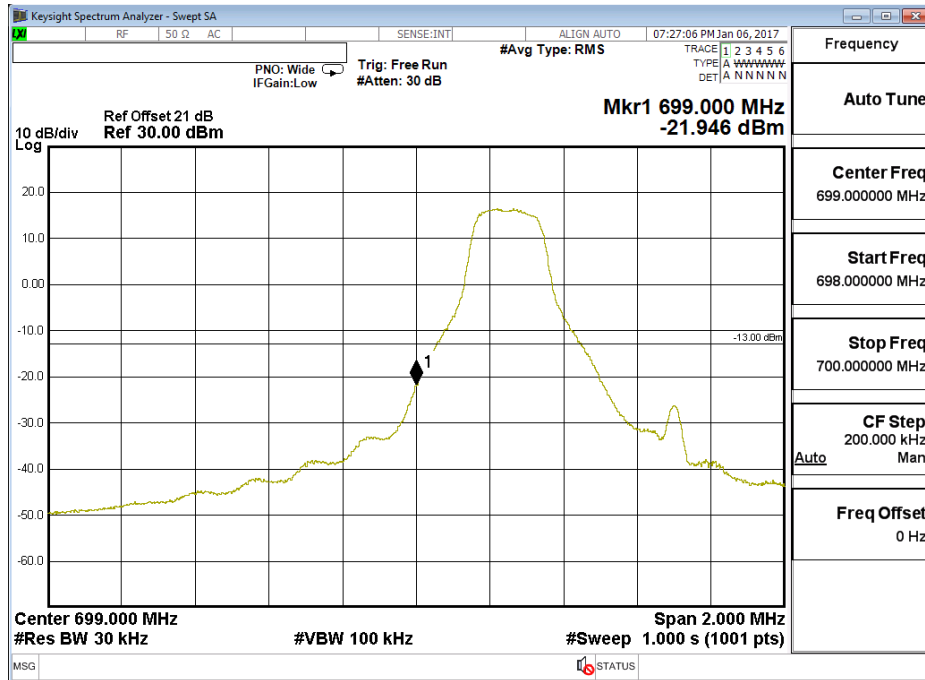

Band 12 (1.4M) QPSK(1,5) Upper Channel 23173 (715.3MHz)

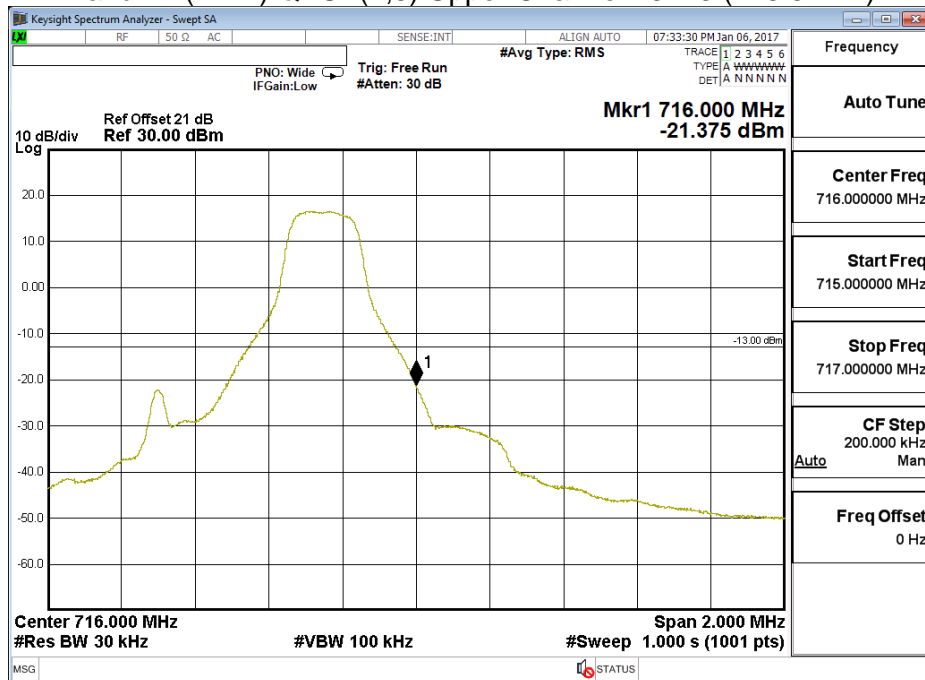

Band 12 (1.4M) QPSK(6,0) Lower Channel 23017 (699.7MHz)

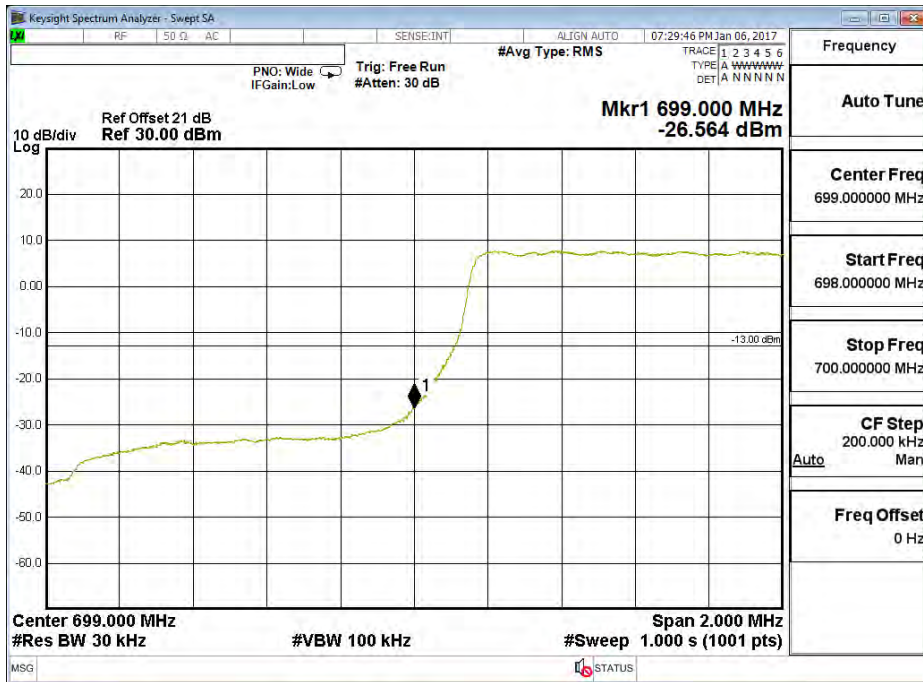

Band 12 (1.4M) QPSK(6,0) Upper Channel 23173 (715.3MHz)

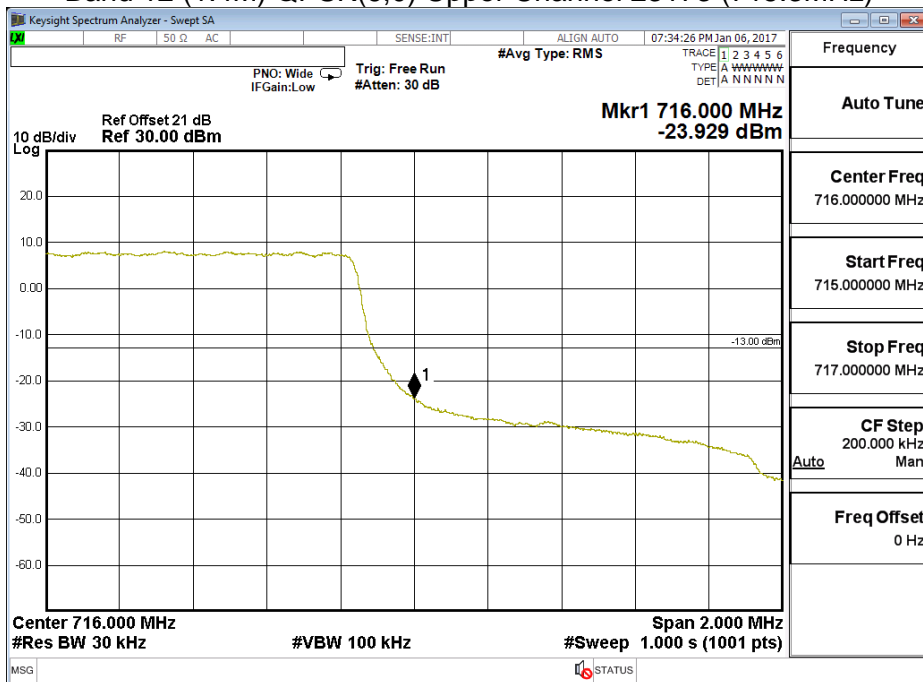

Band 12 (1.4M) 16QAM(1,0) Lower Channel 23017 (699.7MHz)

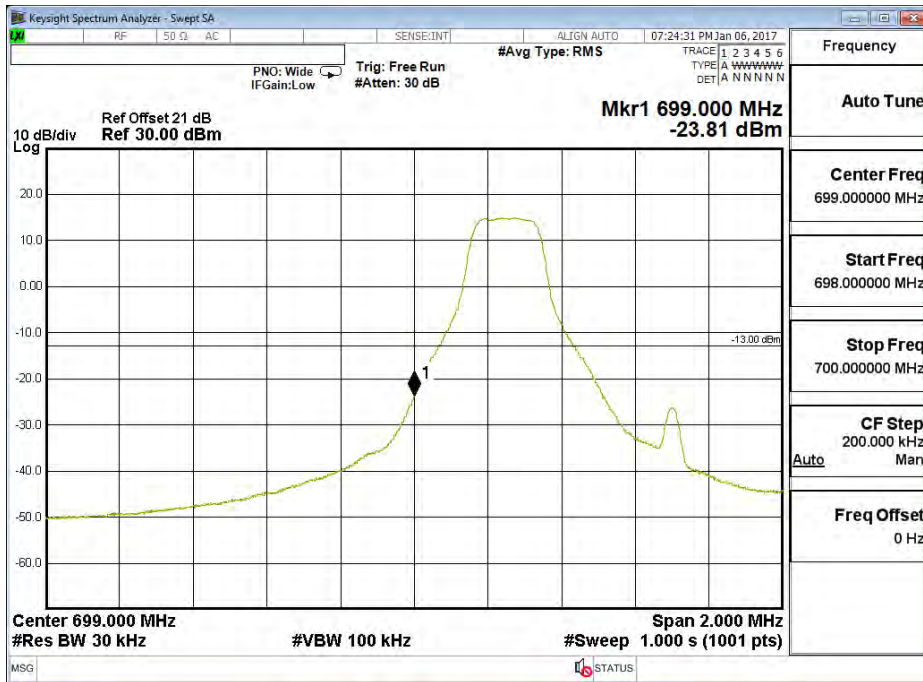

Band 12 (1.4M) 16QAM(1,5) Upper Channel 23173 (715.3MHz)

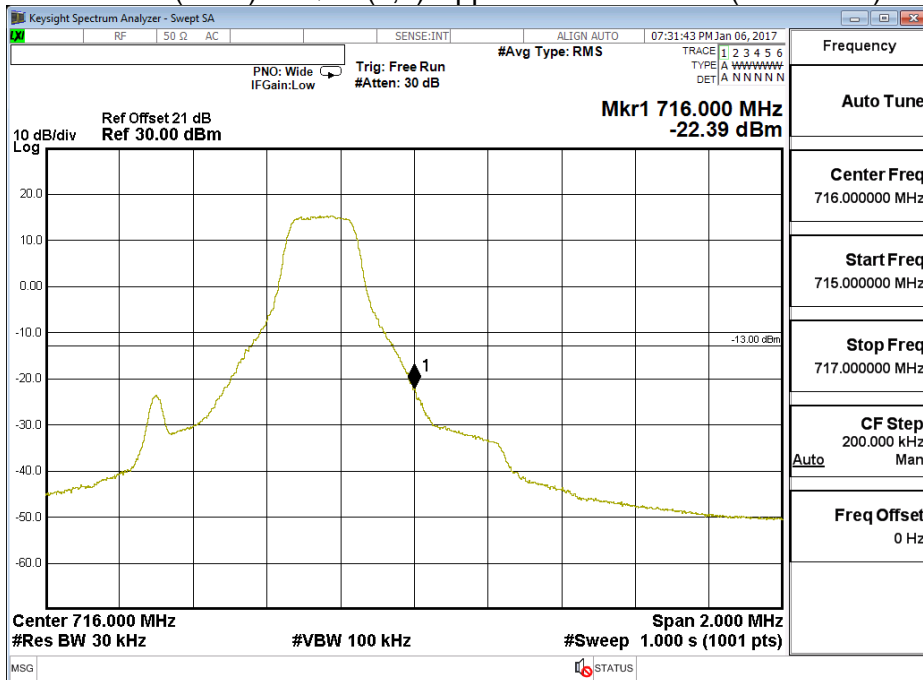

Band 12 (1.4M) 16QAM(6,0) Lower Channel 23017 (699.7MHz)

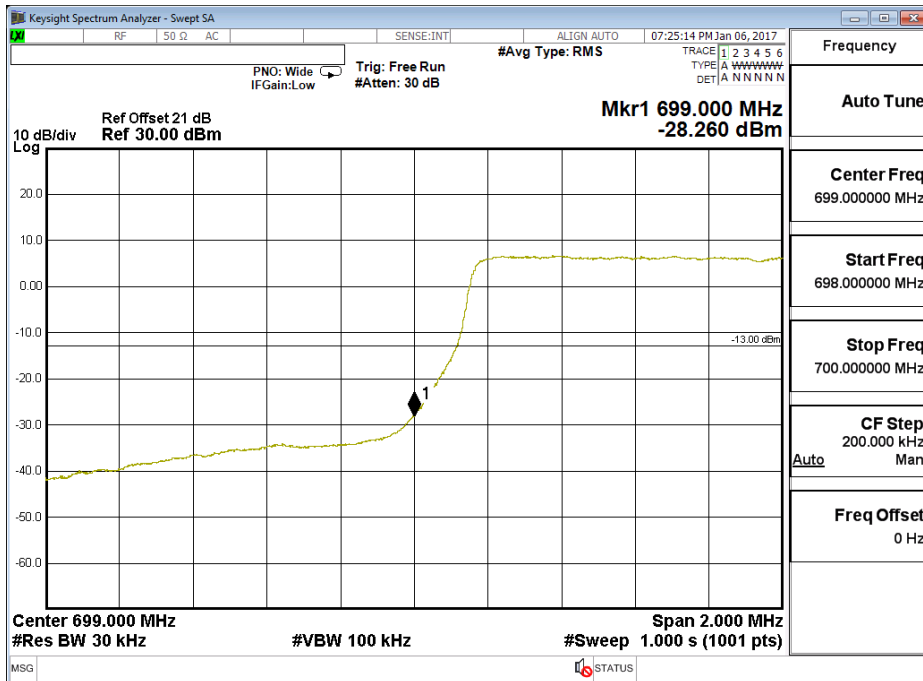

Band 12 (1.4M) 16QAM(6,0) Upper Channel 23173 (715.3MHz)

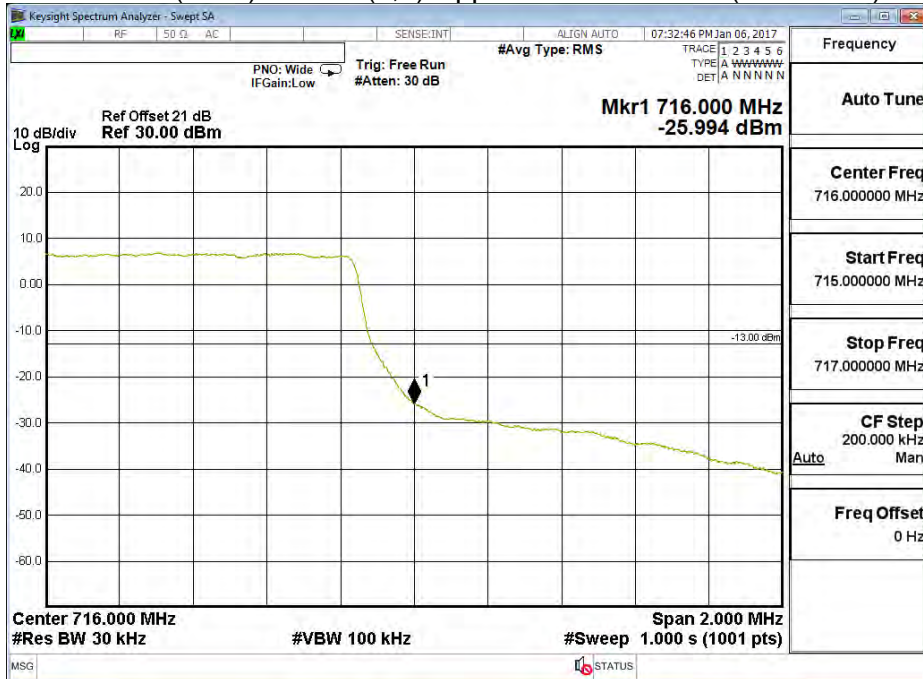



Product	LE910C1-NA		
Test Mode	Spurious Emission At Antenna Terminals (+/-1MHz)		
Date of Test	2017/01/06	Test Site	CTR
Test Condition	Block Edge Test (Band 12 (3M))		

Band 12 (3M) QPSK(1,0) Lower Channel 23025 (700.5MHz)

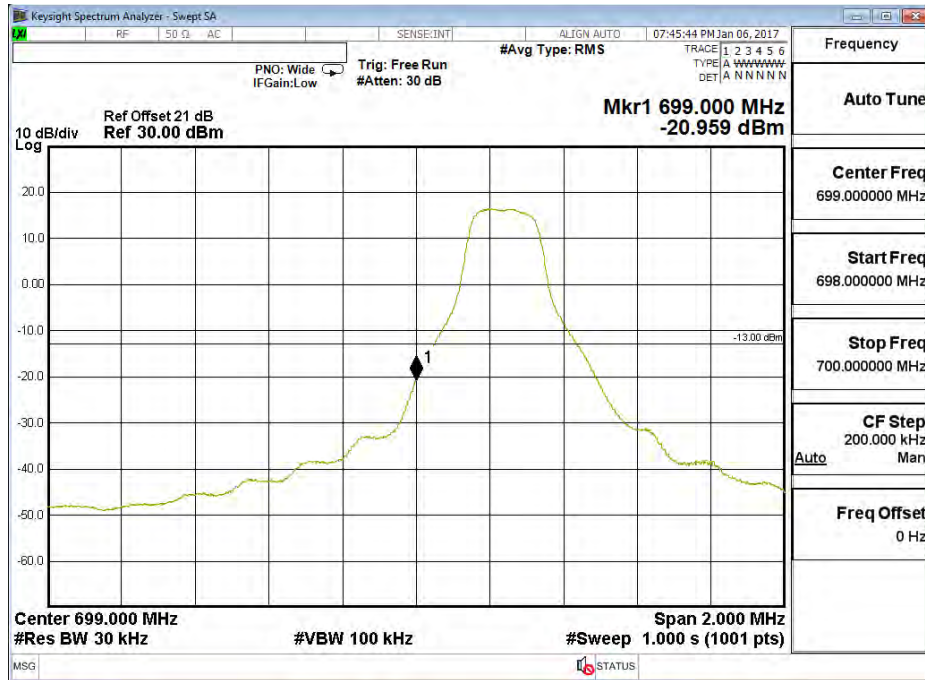

Band 12 (3M) QPSK(1,14) Upper Channel 23165 (714.5MHz)

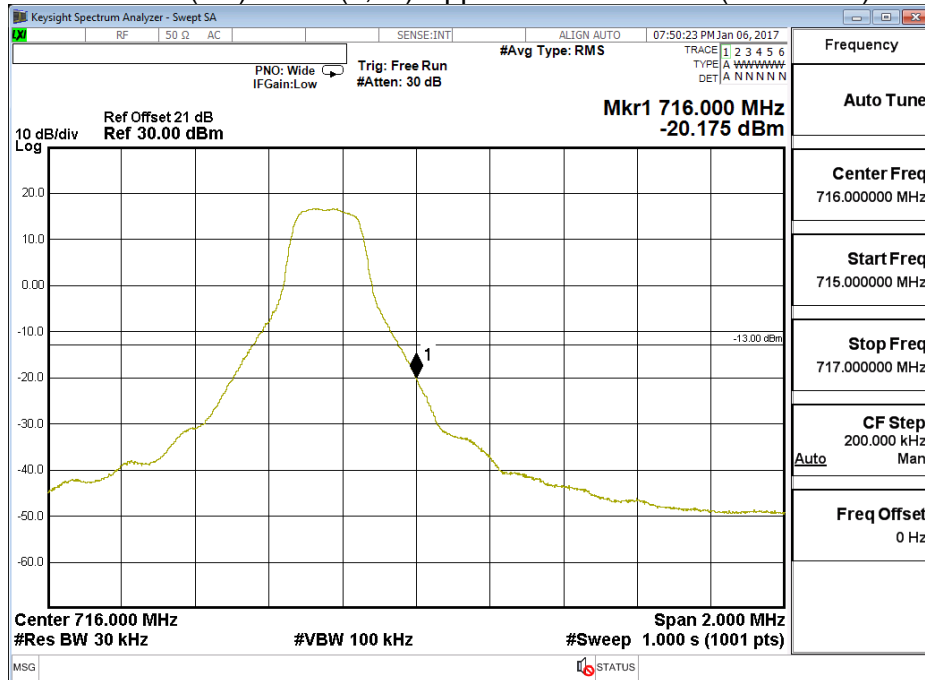

### Band 12 (3M) QPSK(15,0) Lower Channel 23025 (700.5MHz)

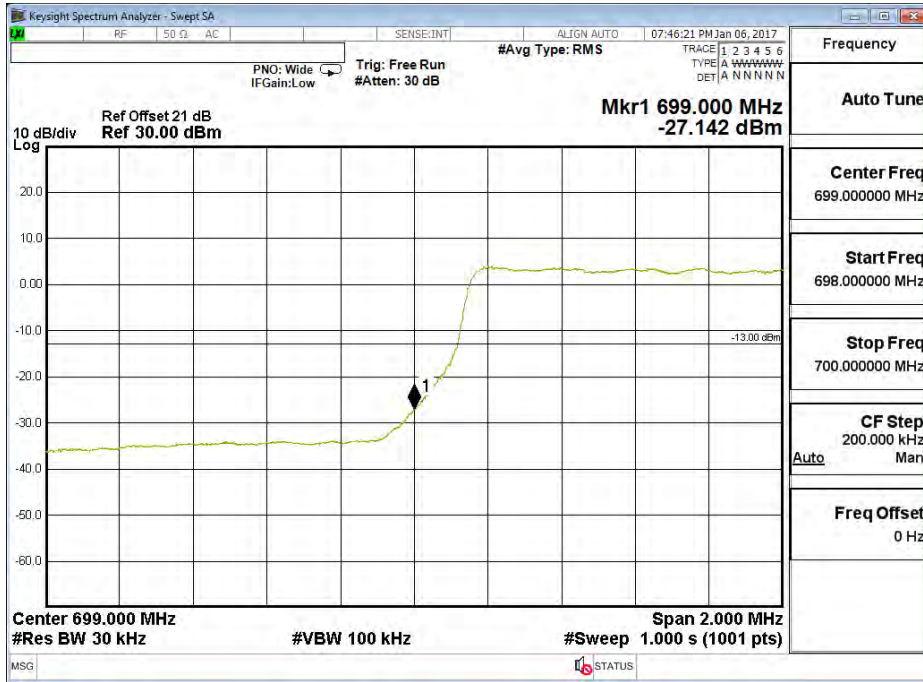

### Band 12 (3M) QPSK(15,0) Upper Channel 23165 (714.5MHz)

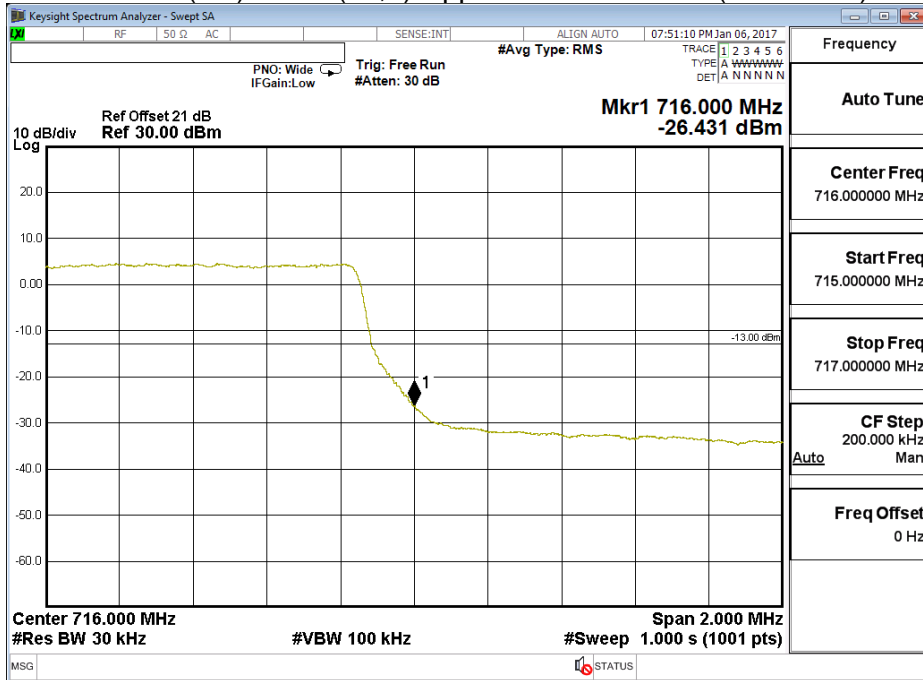

Band 12 (3M) 16QAM(1,0) Lower Channel 23025 (700.5MHz)

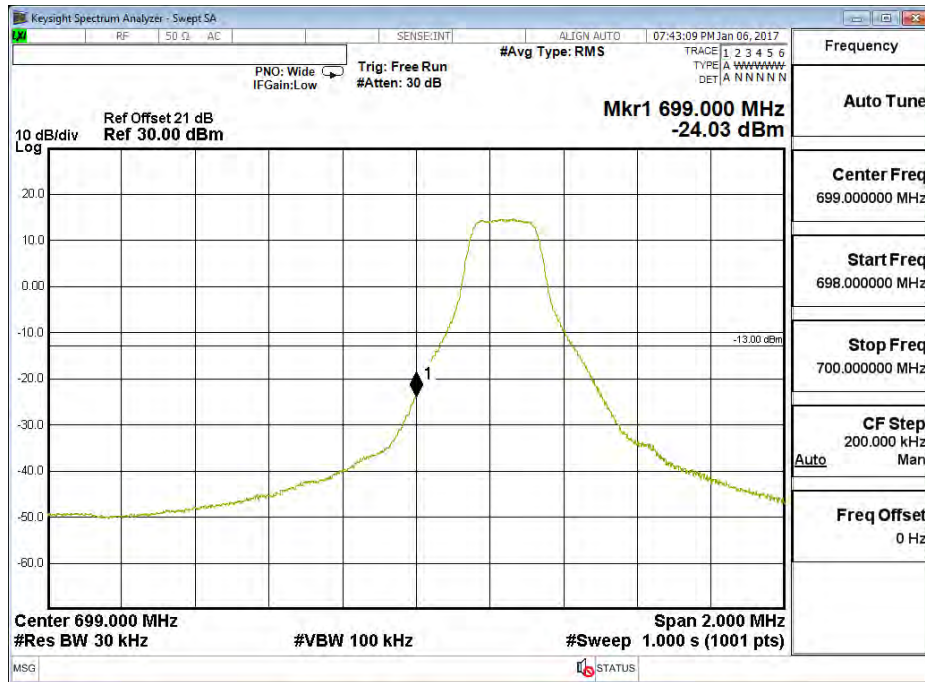

Band 12 (3M) 16QAM(1,14) Upper Channel 23165 (714.5MHz)

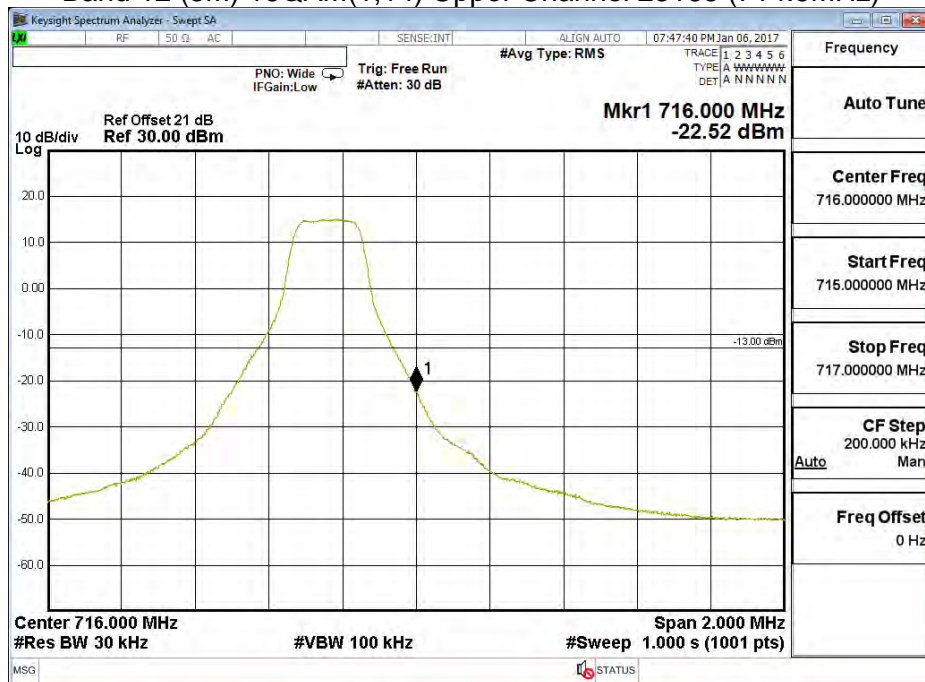

Band 12 (3M) 16QAM(15,0) Lower Channel 23025 (700.5MHz)

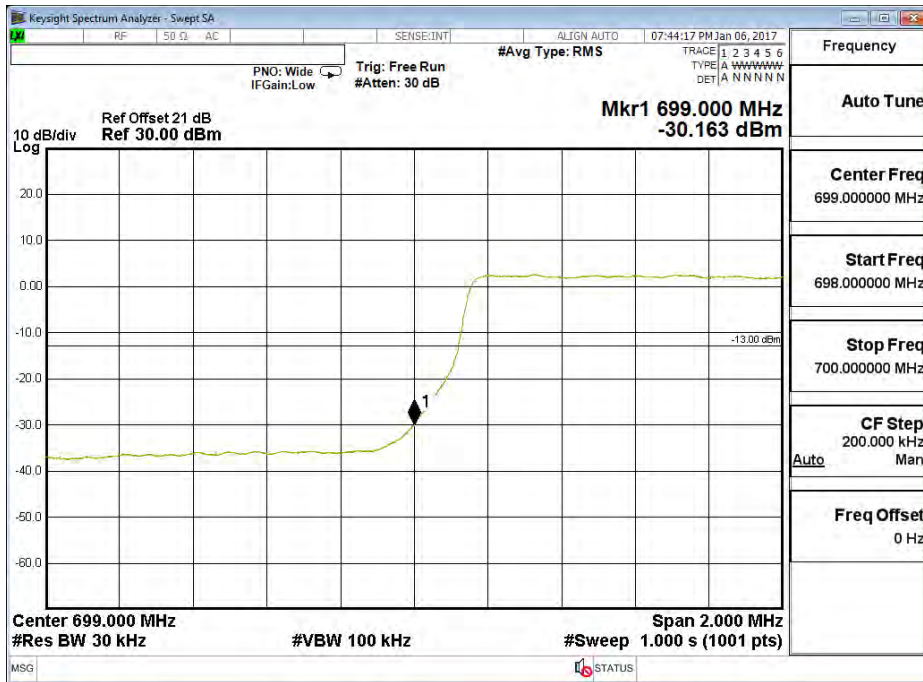

Band 12 (3M) 16QAM(15,0) Upper Channel 23165 (714.5MHz)

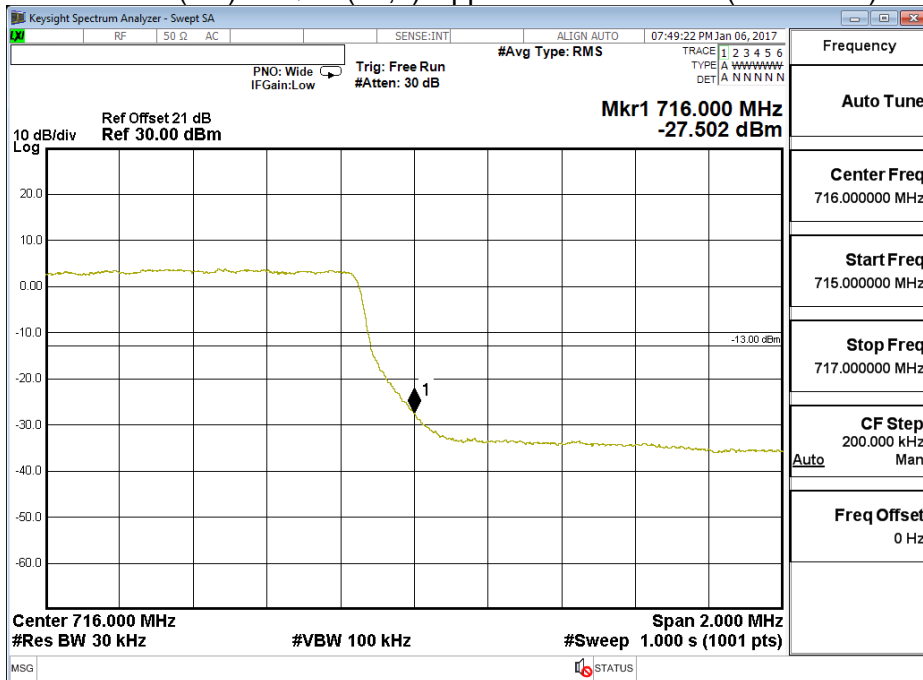

Product	LE910C1-NA		
Test Mode	Spurious Emission At Antenna Terminals (+/-1MHz)		
Date of Test	2017/01/06	Test Site	CTR
Test Condition	Block Edge Test (Band 12 (5M))		

Band 12 (5M) QPSK(1,0) Lower Channel 23035 (701.5MHz)

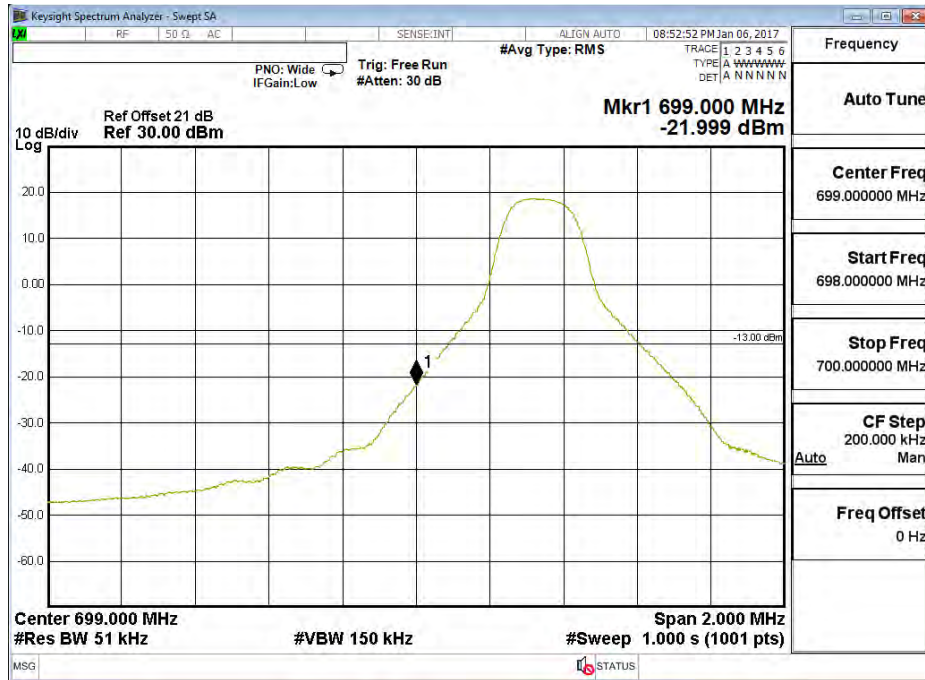

Band 12 (5M) QPSK(1,24) Upper Channel 23155 (713.5MHz)

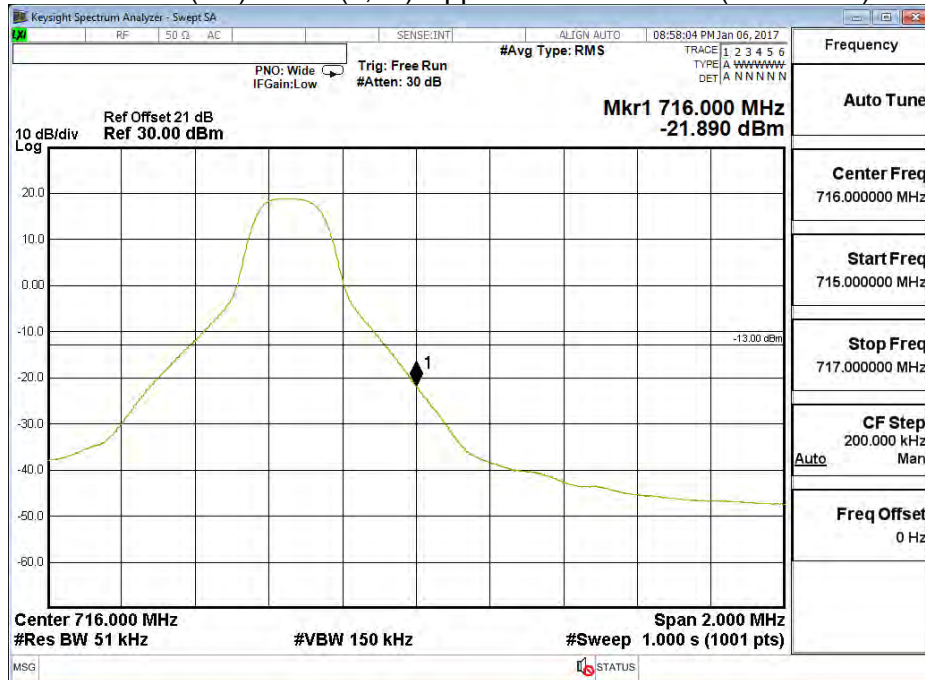

Band 12 (5M) QPSK(25,0) Lower Channel 23035 (701.5MHz)

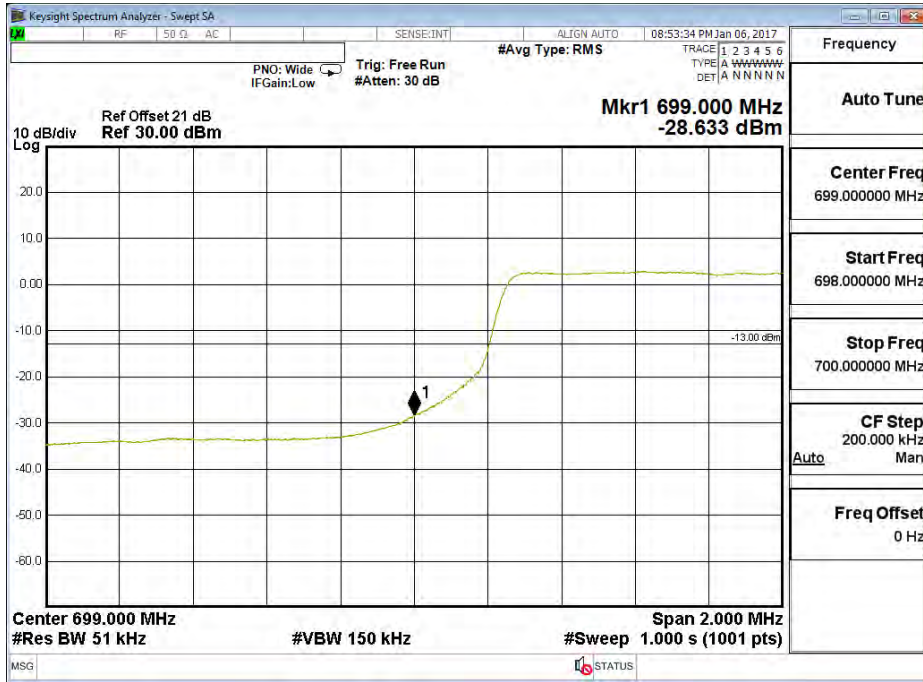

Band 12 (5M) QPSK(25,0) Upper Channel 23155 (713.5MHz)

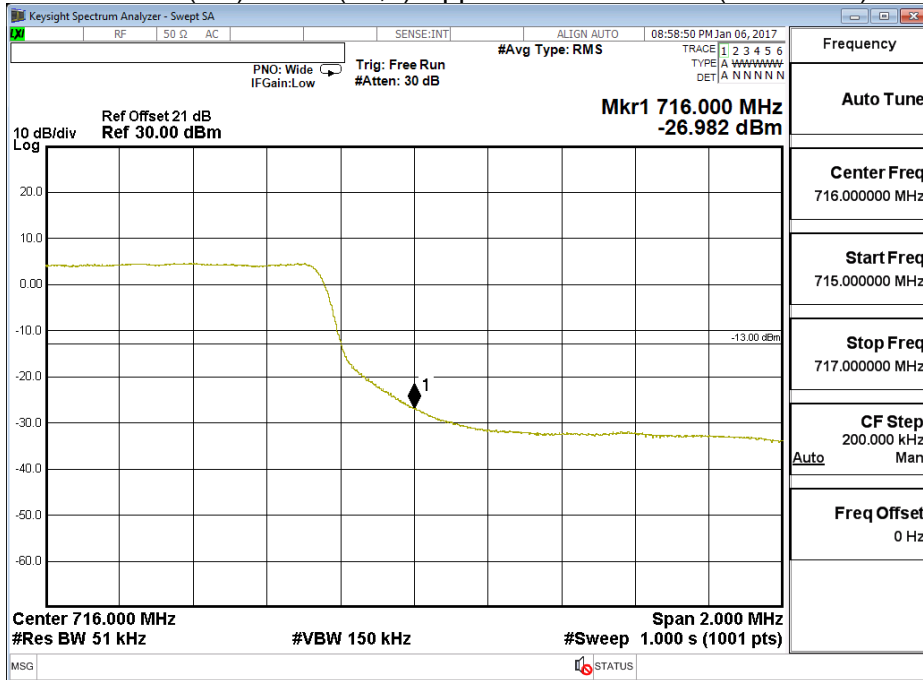

Band 12 (5M) 16QAM(1,0) Lower Channel 23035 (701.5MHz)

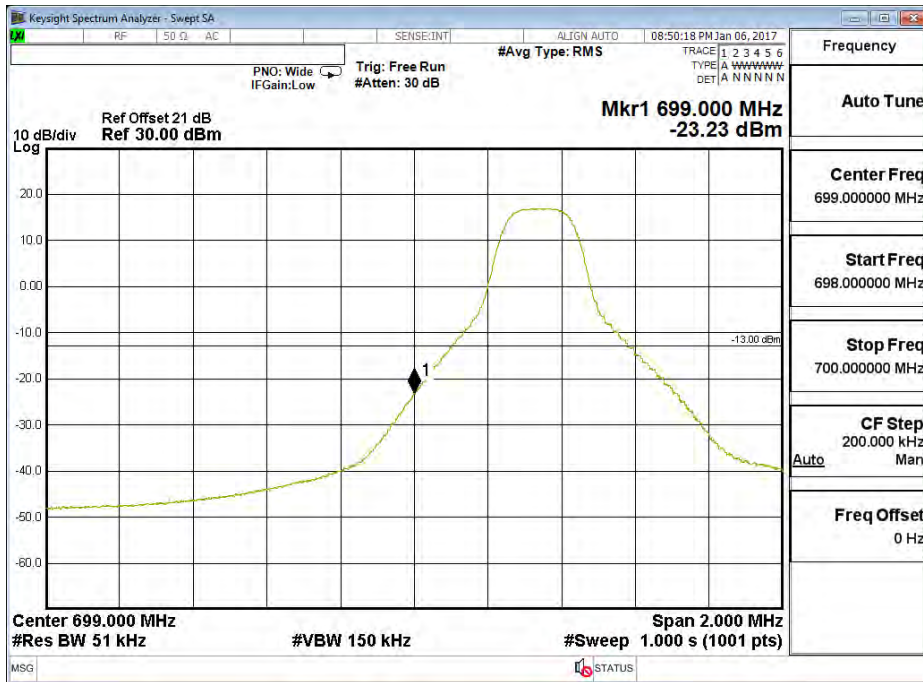

Band 12 (5M) 16QAM(1,24) Upper Channel 23155 (713.5MHz)

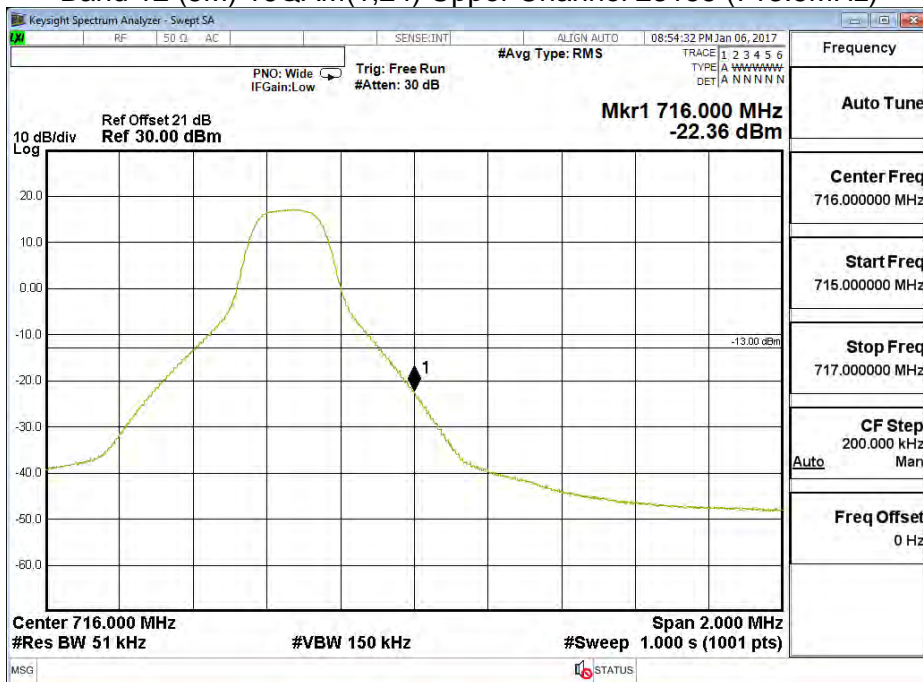

Band 12 (5M) 16QAM(25,0) Lower Channel 23035 (701.5MHz)

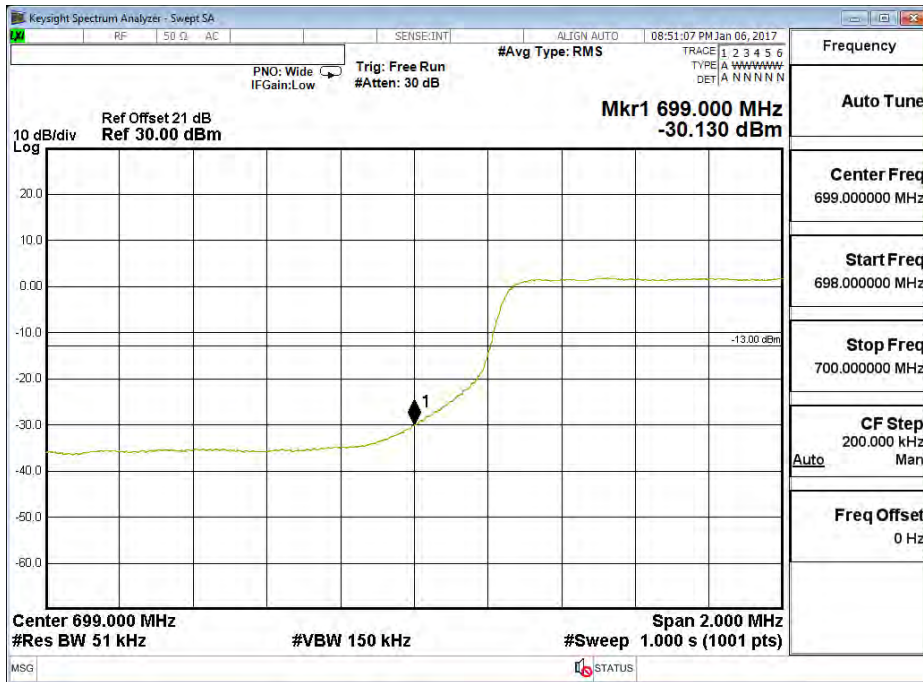

Band 12 (5M) 16QAM(25,0) Upper Channel 23155 (713.5MHz)

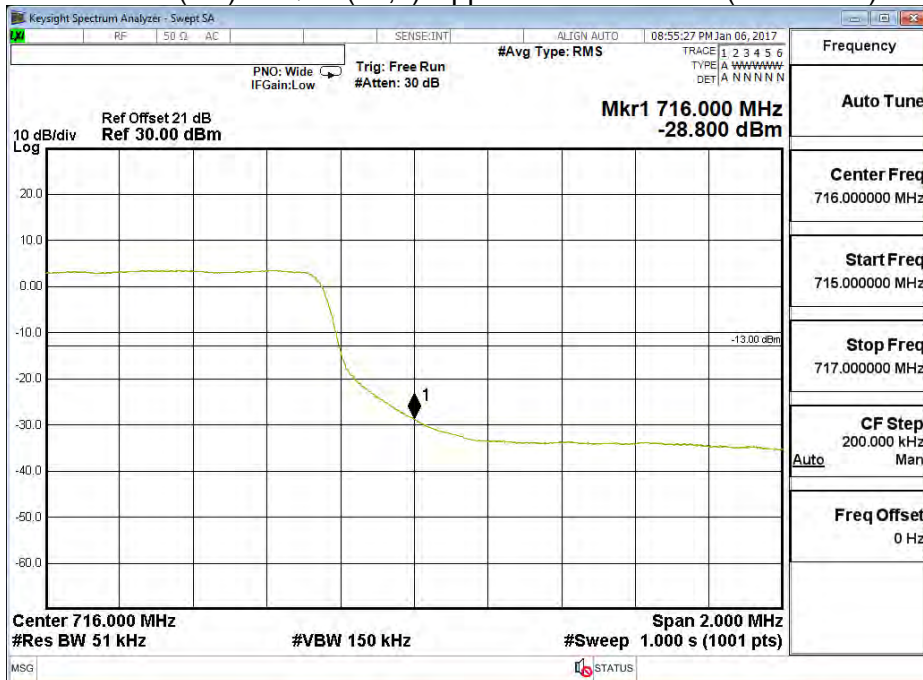



Product	LE910C1-NA		
Test Mode	Spurious Emission At Antenna Terminals (+/-1MHz)		
Date of Test	2017/01/06	Test Site	CTR
Test Condition	Block Edge Test (Band 12 (10M))		

Band 12 (10M) QPSK(1,0) Lower Channel 23060 (704MHz)

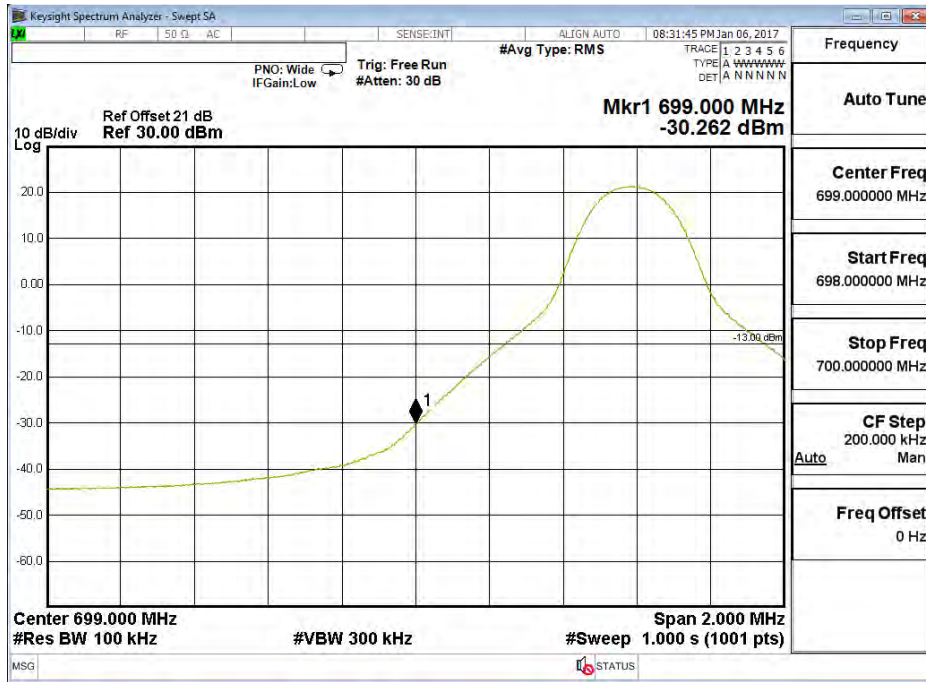

Band 12 (10M) QPSK(1,49) Upper Channel 23130 (711MHz)

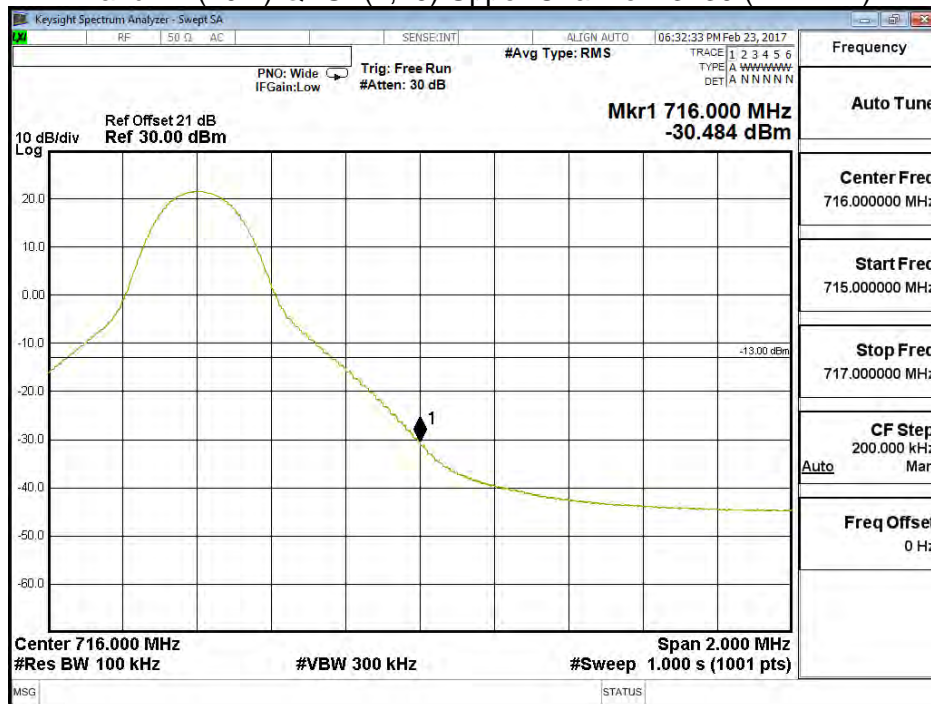

Band 12 (10M) QPSK(50,0) Lower Channel 23060 (704MHz)

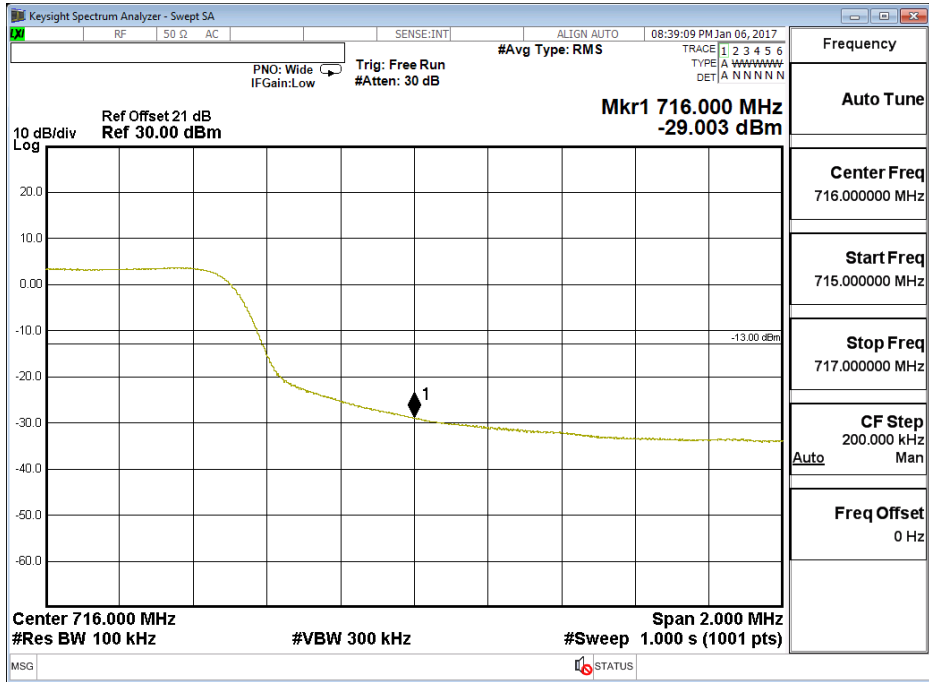

Band 12 (10M) QPSK(50,0) Upper Channel 23130 (711MHz)

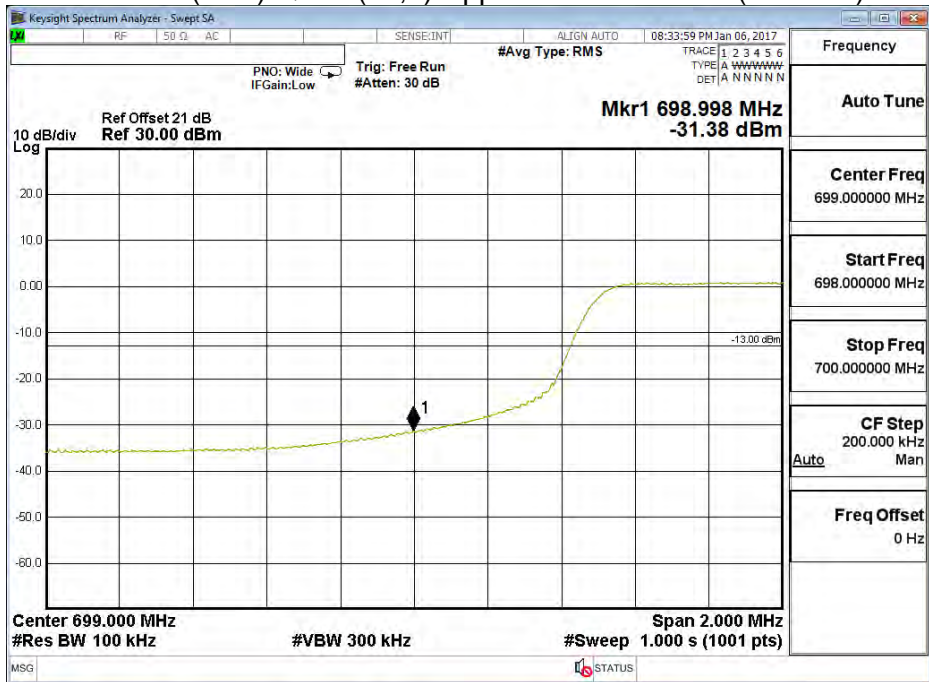

## 6. Spurious Emission

### 6.1. Test Specification

According to Part 2.1051, 2.1053, 24.238, 27.53  
 RSS GEN, RSS 130, RSS 133, RSS 139

### 6.2. Test Setup

#### 6.2.1 Spurious emissions at antenna terminals.

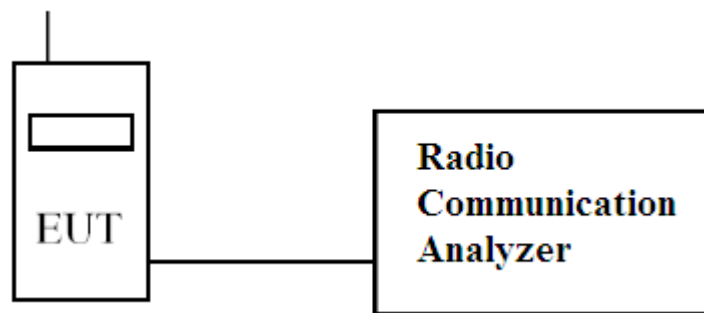

#### 6.2.2 Field strength of spurious radiation.

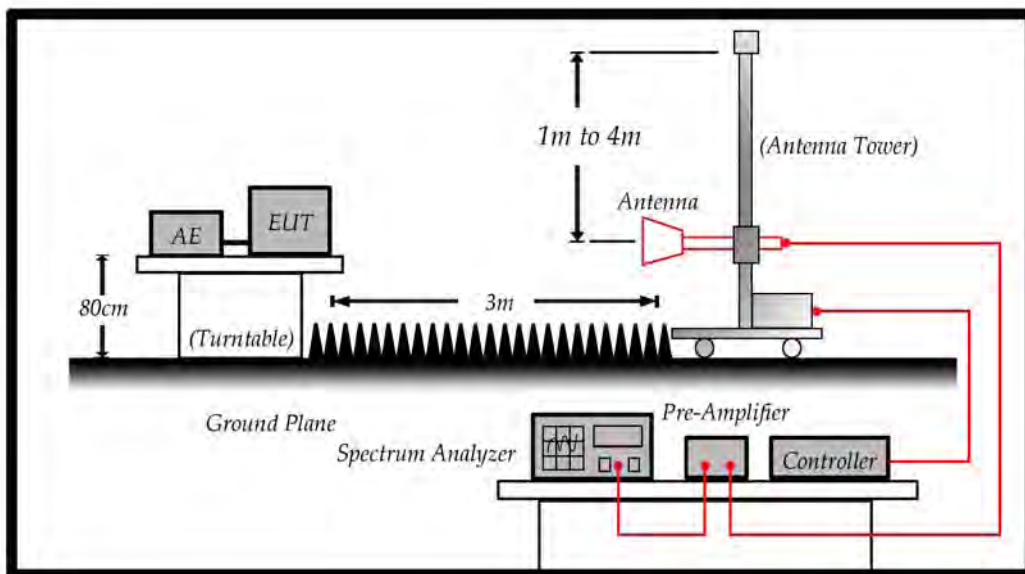

Note: The Worst case Mode is QPSK Mode for Radiated spurious emissions.

### 6.3. Limits

<b>Limit</b>	<b>&lt;-13dBm</b>
--------------	-------------------

$43 + 10\text{Log}(P)$  down on the carrier where P is the power in Watts.

### 6.4. Test Procedure

In accordance with Part 2.1051, 2.1053, 24.238, 27.53, RSS GEN, RSS 130, RSS 133, RSS 139., the spurious emissions from the antenna terminal were measured. The transmitter output power was attenuated using a combination of filters and attenuators and the frequency spectrum investigated from 30MHz to 20GHz. The EUT was set to transmit on full power. The EUT was tested on Low, middle and High channels for both power levels. The resolution and video bandwidth was set to 1MHz/3MHz in accordance with Part 2.1051, 2.1053, 24.238, 27.53, RSS GEN, RSS 130, RSS 133, RSS 139., The spectrum analyzer detector was set to Max Hold. In addition, measurements were made up to the 10<sup>th</sup> harmonic of the fundamental. The device was then replaced with a substitution antenna, which input signal was adjusted until the received level matched that of the previously detected emission.

- (1) The EUT is tested with maximum rated TX power via the Base Station simulator.
- (2) The EUT is tested in three orthogonal planes, The worst case was showing in this report.

The EUT is placed on a turn table which is 1.5 meter above ground. The turn table can rotate 360 degrees to determine the position of the maximum emission level. The EUT was positioned such that the distance from antenna to the EUT was 3 meters.

The antenna can move up and down between 1 meter and 4 meters to find out the maximum emission level.

Both horizontal and vertical polarization of the antenna are set on measurement. In order to find the maximum emission, all of the interface cables must be manipulated according to TIA/EIA 603-D on radiated measurement.

### 6.5. Test Result of Spurious Emission

Product	LE910C1-NA		
Test Mode	Spurious Emission (Conducted)		
Date of Test	2017/02/08	Test Site	CTR
Test Condition	LTE-Band 2 (1.4M)	Test Range	30MHz~20GHz

#### LTE-Band 2 (1.4M) QPSK(3,2) CH18607 (1850.7MHz)

Frequency (MHz)	Reading Level (dBm)	Path Loss (dB)	Emission Level (dBm)	Limit (dBm)
3701	-57.960	1.1	-56.860	-13
5552	-54.950	1.23	-53.720	-13
7403	-57.350	1.59	-55.760	-13
9254	-64.340	1.89	-62.450	-13
11104	-66.545	2.07	-64.475	-13
12955	-63.852	2.26	-61.592	-13
14806	-62.395	2.64	-59.755	-13
16656	-58.964	3.5	-55.464	-13
18507	-60.728	3.7	-57.028	-13

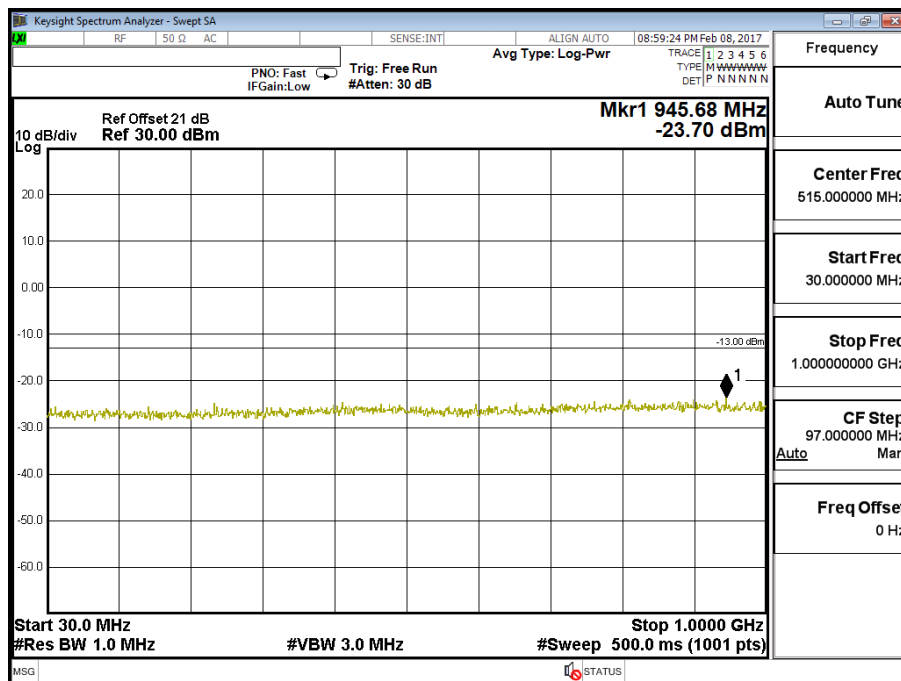

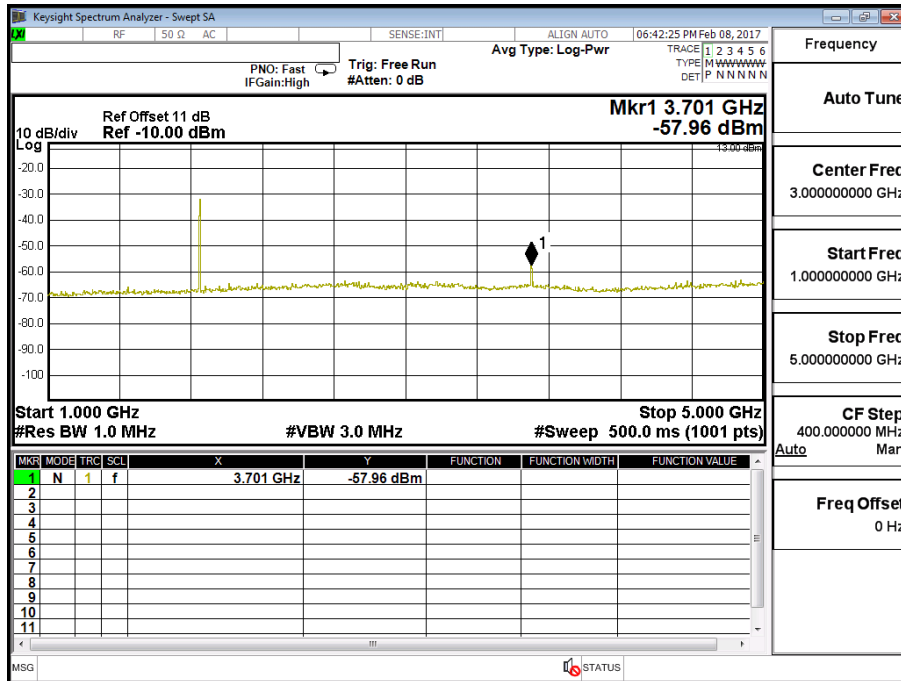

Frequency	Auto Tune
Center Freq	3.000000000 GHz
Start Freq	1.000000000 GHz
Stop Freq	5.000000000 GHz
CF Step	400.0000000 MHz
Auto	Man
Freq Offset	0 Hz

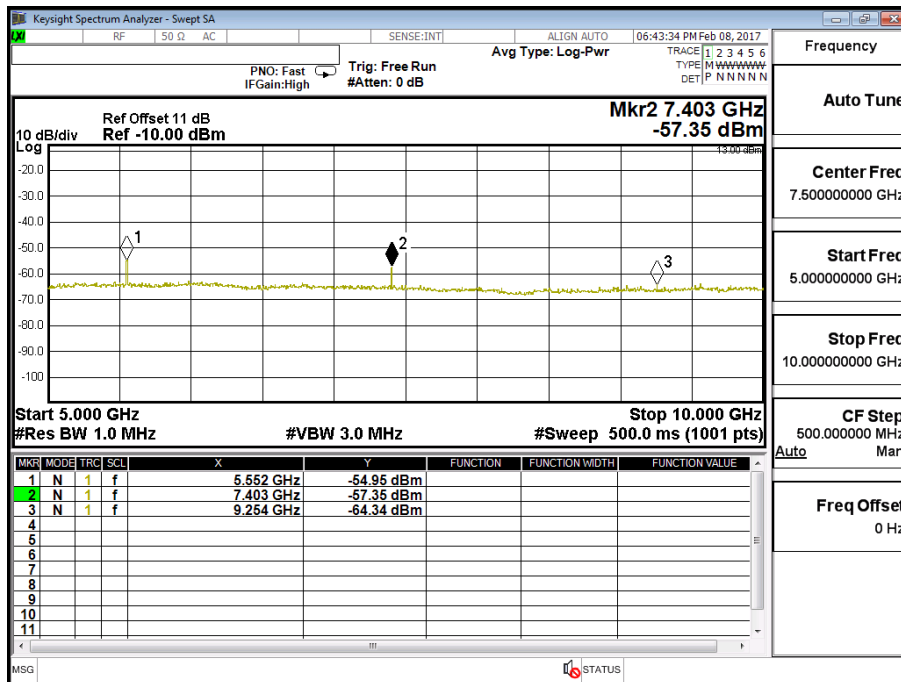

Frequency	Auto Tune
Center Freq	7.500000000 GHz
Start Freq	5.000000000 GHz
Stop Freq	10.000000000 GHz
CF Step	500.0000000 MHz
Auto	Man
Freq Offset	0 Hz

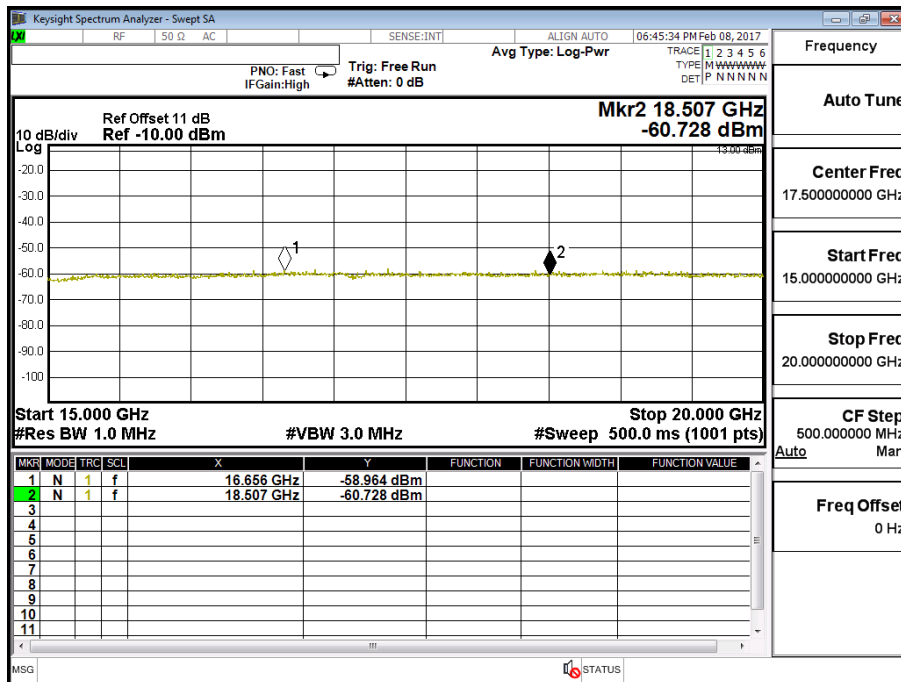
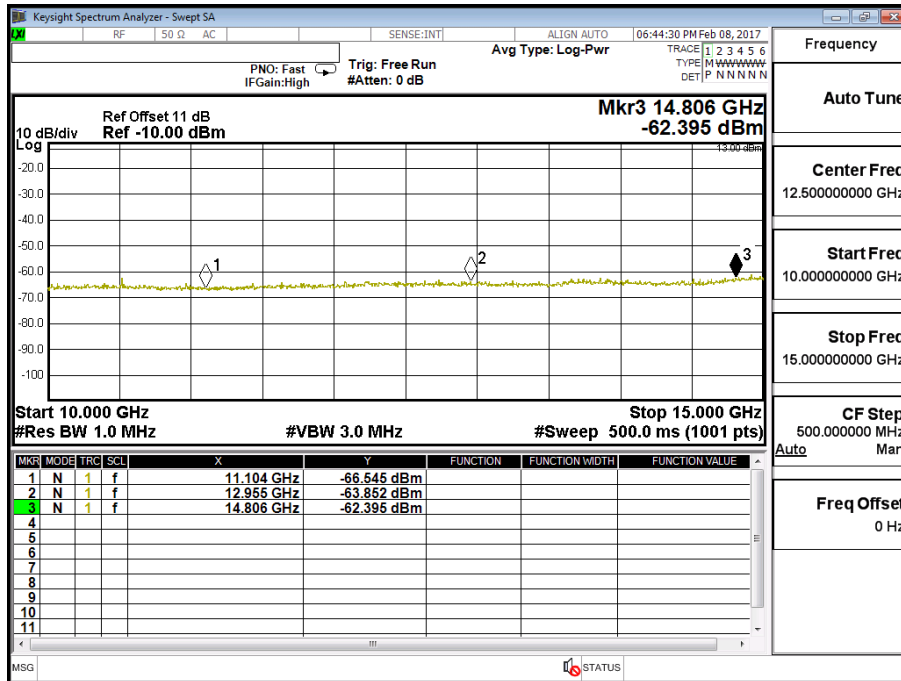

Product	LE910C1-NA		
Test Mode	Spurious Emission (Conducted)		
Date of Test	2017/02/08	Test Site	CTR
Test Condition	LTE-Band 2 (1.4M)	Test Range	30MHz~20GHz

**LTE-Band 2 (1.4M) 16QAM(1,3) CH18607 (1850.7MHz)**

Frequency (MHz)	Reading Level (dBm)	Path Loss (dB)	Emission Level (dBm)	Limit (dBm)
3701	-58.260	1.1	-57.160	-13
5552	-55.153	1.23	-53.923	-13
7403	-56.846	1.59	-55.256	-13
9254	-63.859	1.89	-61.969	-13
11104	-66.195	2.07	-64.125	-13
12955	-64.656	2.26	-62.396	-13
14806	-62.275	2.64	-59.635	-13
16656	-59.522	3.5	-56.022	-13
18507	-59.339	3.7	-55.639	-13

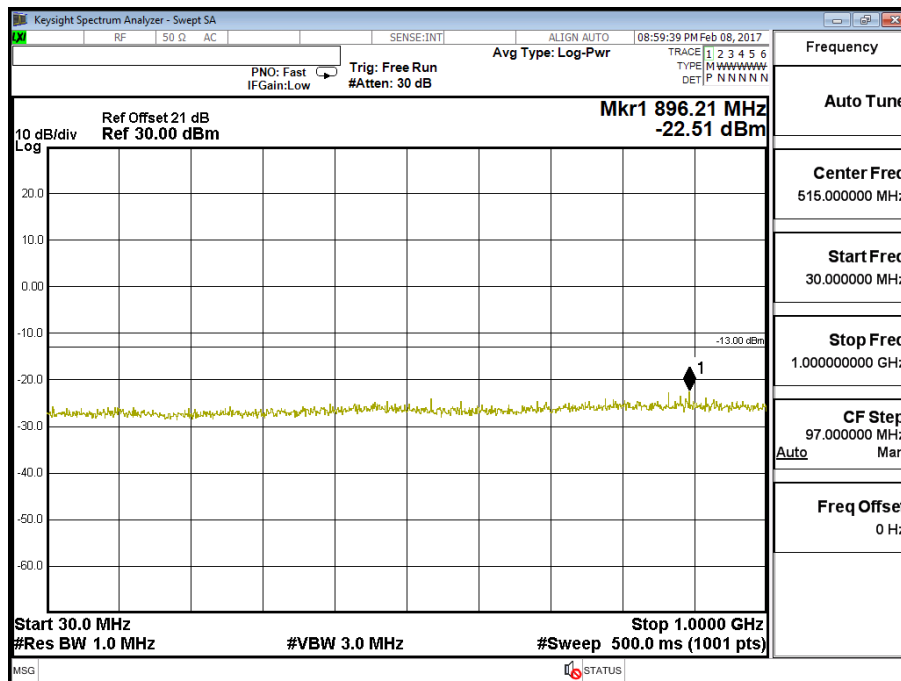



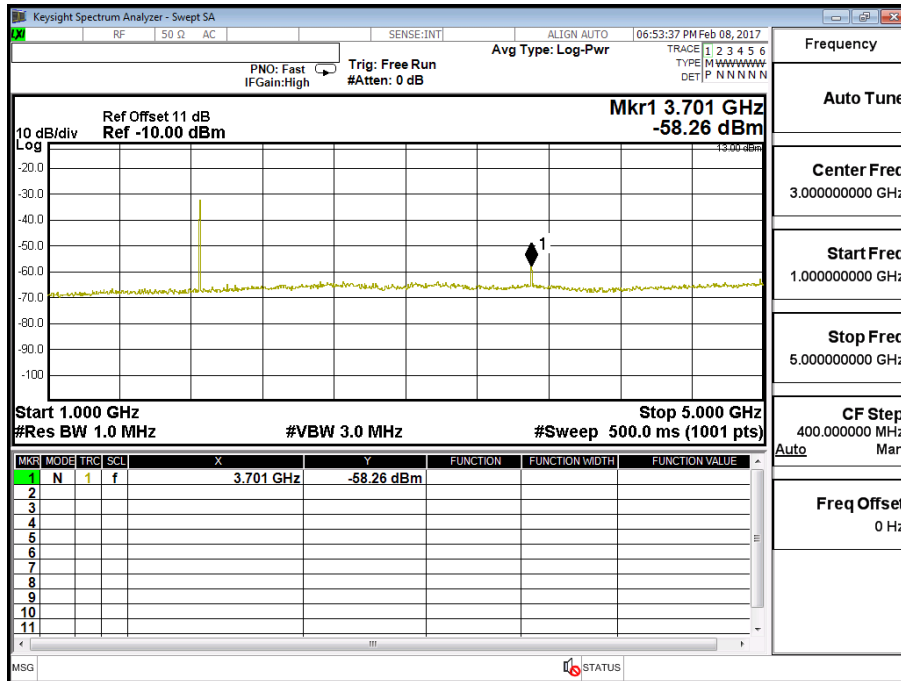

Frequency	Auto Tune
Center Freq	3.000000000 GHz
Start Freq	1.000000000 GHz
Stop Freq	5.000000000 GHz
CF Step	400.0000000 MHz
Freq Offset	0 Hz

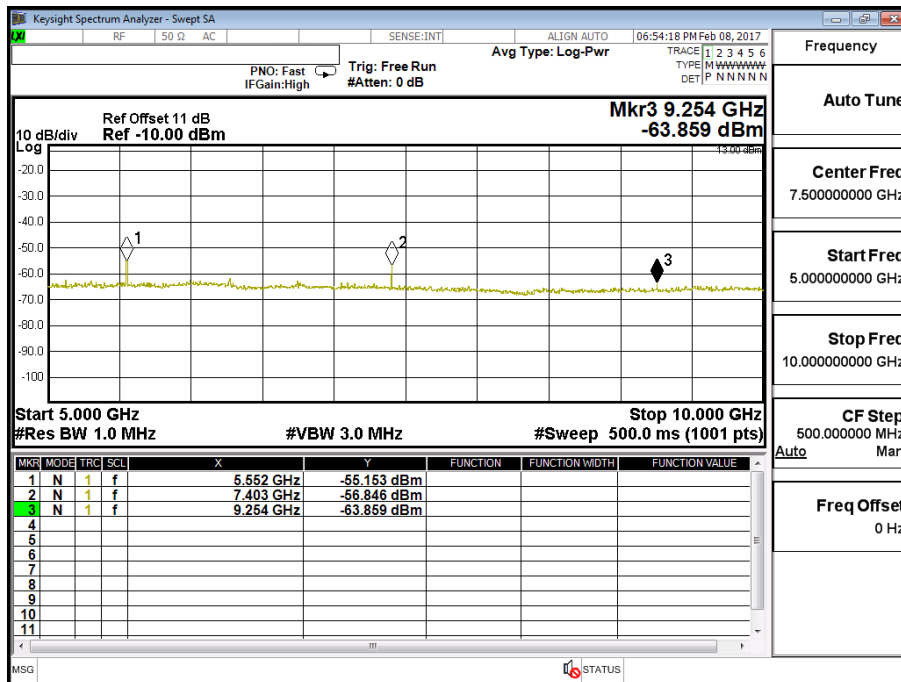

Frequency	Auto Tune
Center Freq	7.500000000 GHz
Start Freq	5.000000000 GHz
Stop Freq	10.000000000 GHz
CF Step	500.0000000 MHz
Freq Offset	0 Hz

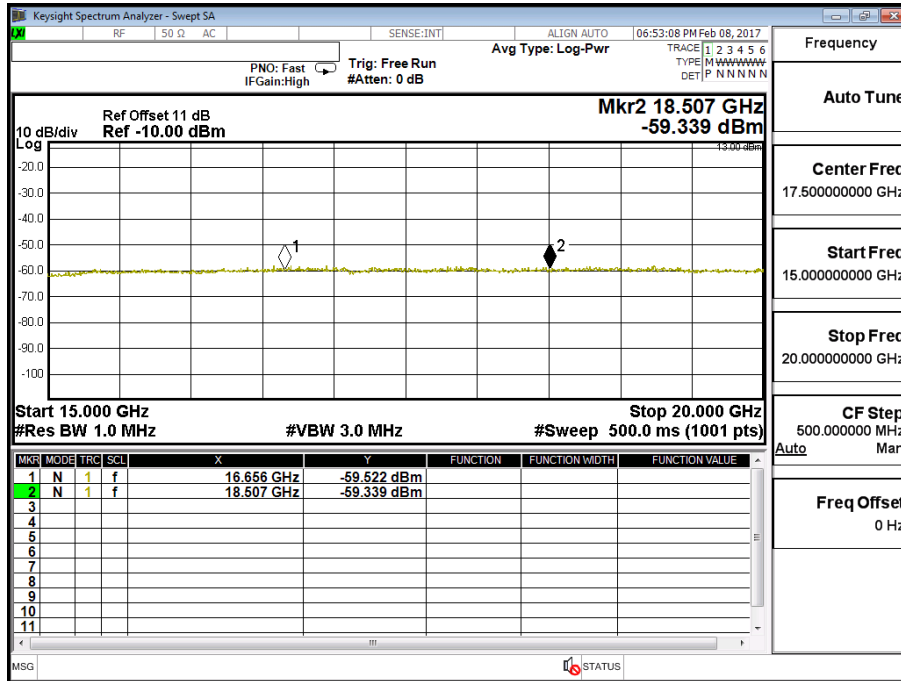
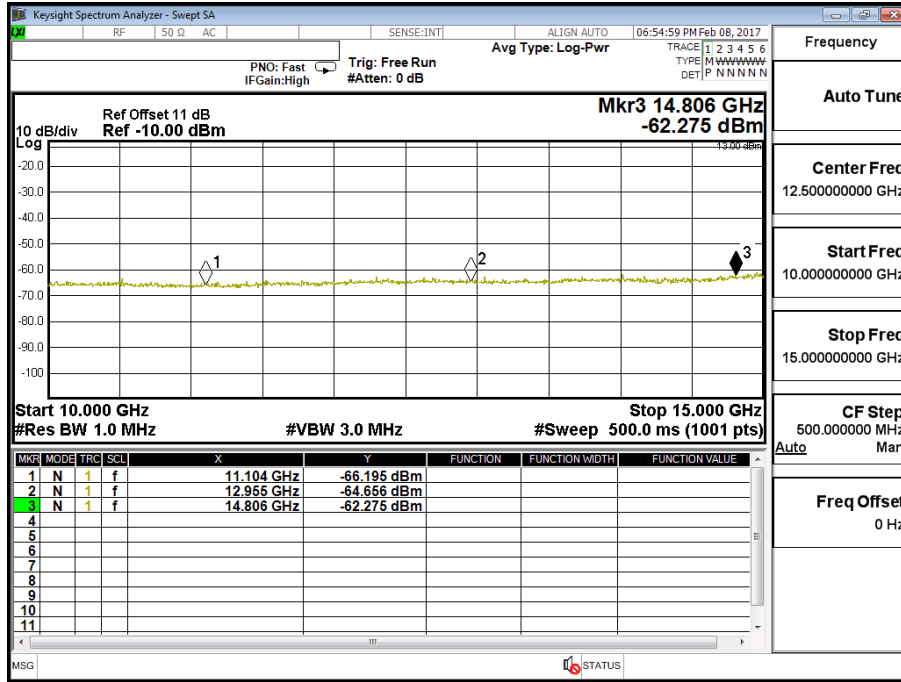

Product	LE910C1-NA		
Test Mode	Spurious Emission (Conducted)		
Date of Test	2017/02/08	Test Site	CTR
Test Condition	LTE-Band 2 (3M)	Test Range	30MHz~20GHz

**LTE-Band 2 (3M) QPSK(1,7) CH18615 (1851.5MHz)**

Frequency (MHz)	Reading Level (dBm)	Path Loss (dB)	Emission Level (dBm)	Limit (dBm)
3703	-56.776	1.1	-55.676	-13
5555	-54.141	1.23	-52.911	-13
7406	-56.825	1.59	-55.235	-13
9258	-63.972	1.89	-62.082	-13
11109	-65.731	2.07	-63.661	-13
12961	-64.270	2.26	-62.010	-13
14812	-62.582	2.64	-59.942	-13
16664	-60.713	3.5	-57.213	-13
18515	-60.843	3.7	-57.143	-13

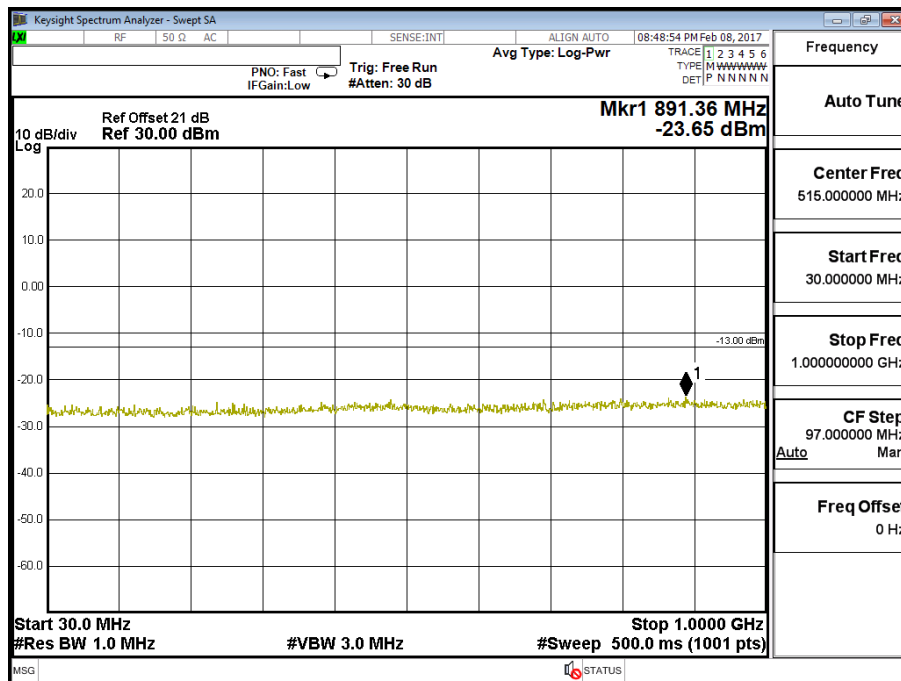

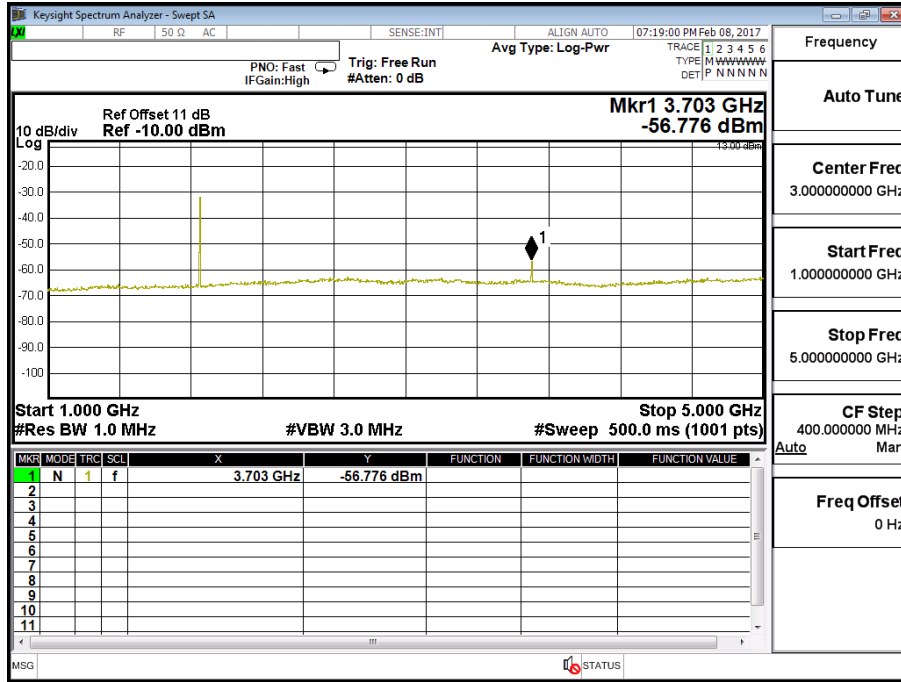

Frequency	Auto Tune
Center Freq	3.000000000 GHz
Start Freq	1.000000000 GHz
Stop Freq	5.000000000 GHz
CF Step	400.0000000 MHz
Auto Man	Man
Freq Offset	0 Hz

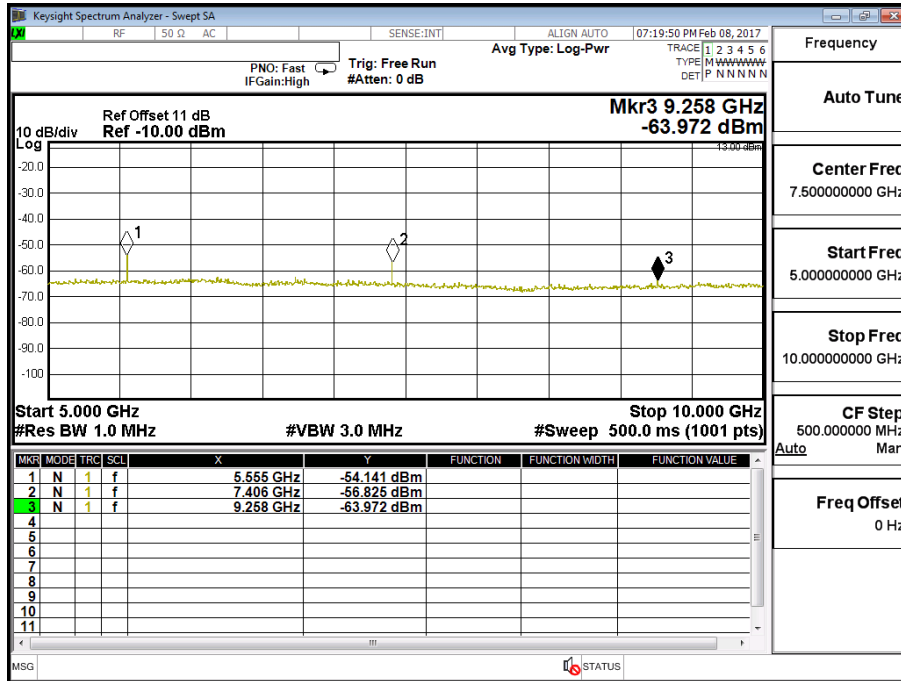

Frequency	Auto Tune
Center Freq	7.500000000 GHz
Start Freq	5.000000000 GHz
Stop Freq	10.000000000 GHz
CF Step	500.0000000 MHz
Auto Man	Man
Freq Offset	0 Hz

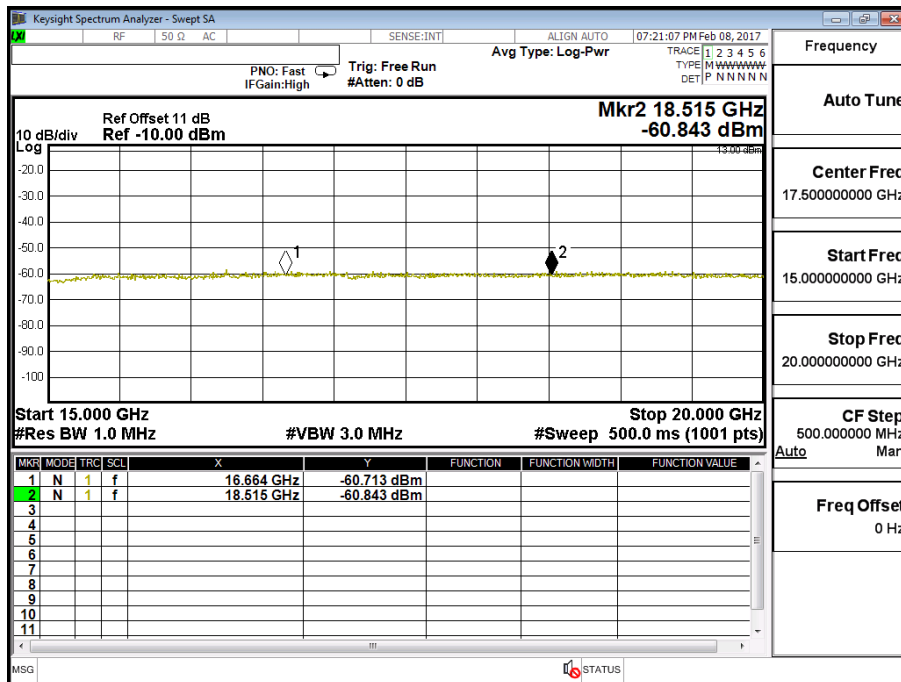
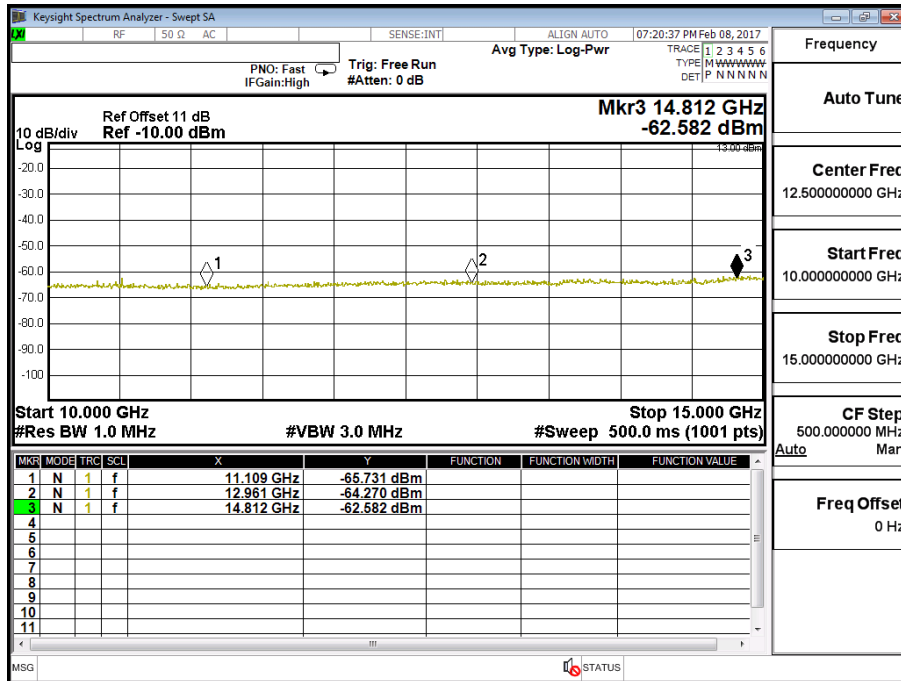



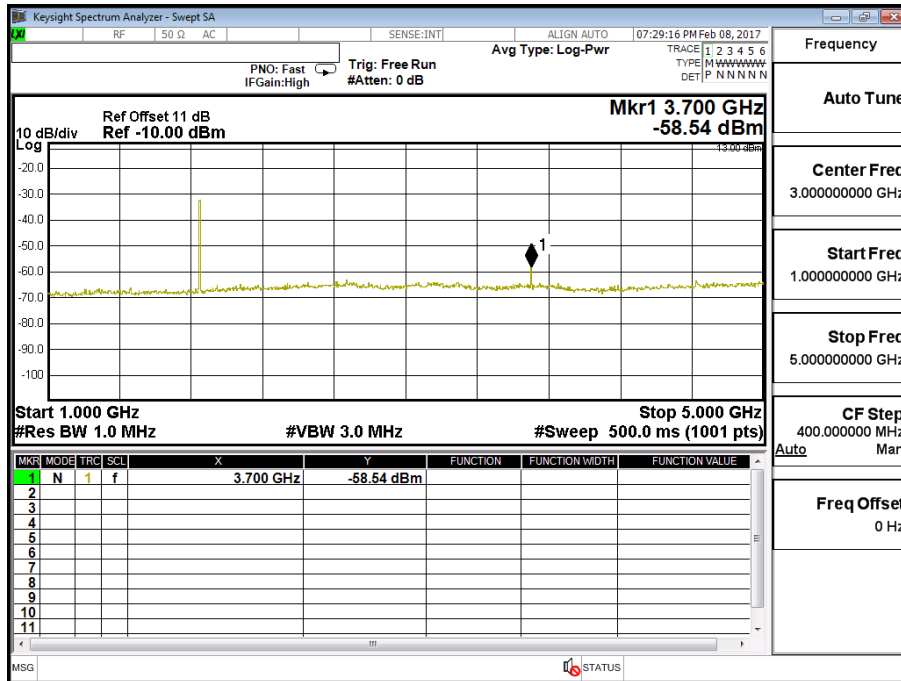

Frequency	Auto Tune
Center Freq	3.000000000 GHz
Start Freq	1.000000000 GHz
Stop Freq	5.000000000 GHz
CF Step	400.0000000 MHz
Freq Offset	0 Hz

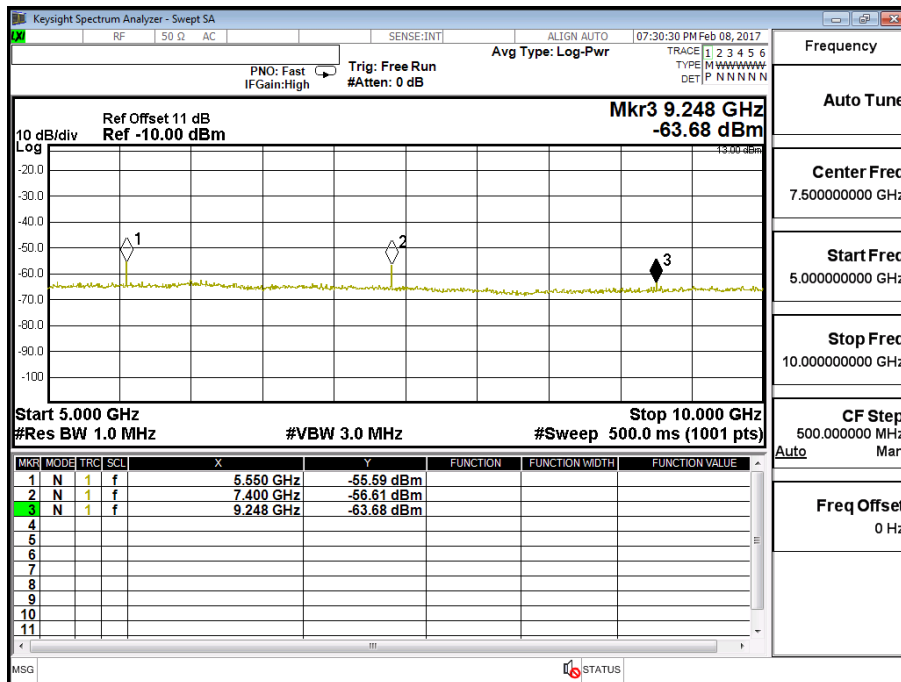

Frequency	Auto Tune
Center Freq	7.500000000 GHz
Start Freq	5.000000000 GHz
Stop Freq	10.000000000 GHz
CF Step	500.0000000 MHz
Freq Offset	0 Hz





Product	LE910C1-NA		
Test Mode	Spurious Emission (Conducted)		
Date of Test	2017/02/08	Test Site	CTR
Test Condition	LTE-Band 2 (5M)	Test Range	30MHz~20GHz

**LTE-Band 2 (5M) QPSK(1,0) CH19175 (1907.5MHz)**

Frequency (MHz)	Reading Level (dBm)	Path Loss (dB)	Emission Level (dBm)	Limit (dBm)
3704	-58.430	1.1	-57.330	-13
5558	-55.070	1.23	-53.840	-13
7410	-56.730	1.59	-55.140	-13
9260	-63.460	1.89	-61.570	-13
11115	-64.466	2.07	-62.396	-13
12953	-63.376	2.26	-61.116	-13
14835	-61.686	2.64	-59.046	-13
16663	-59.590	3.5	-56.090	-13
18525	-60.800	3.7	-57.100	-13

