



FCC Part 15C Test Report

FCC ID: 2AA8L002

Product Name:	USB RF Receiver
Trademark:	N/A
Model Name :	RF-RX002
Prepared For :	ODSONIC INTERNATIONAL (HK) CO., LIMITED
Address :	FLAT/RM 704 7F, BRIGHT WAY TOWER 33 MONG KOK ROAD, MONG KOK, KL, Hong Kong
Prepared By :	Shenzhen BCTC Technology Co., Ltd.
Address :	No.101, Yousong Road, Longhua New District, Shenzhen, China
Test Date:	Jun. 29 – Jul. 4, 2016
Date of Report :	Jul. 7, 2016
Report No.:	BCTC-160608286E



TEST RESULT CERTIFICATION

Applicant's name : ODSONIC INTERNATIONAL (HK) CO., LIMITED
Address : FLAT/RM 704 7F, BRIGHT WAY TOWER 33 MONG KOK ROAD,
MONG KOK, KL, Hong Kong
Manufacture's Name..... : ODSONIC INTERNATIONAL (HK) CO., LIMITED
Address : FLAT/RM 704 7F, BRIGHT WAY TOWER 33 MONG KOK ROAD,
MONG KOK, KL, Hong Kong

Product description

Product name : USB RF Receiver
Trademark..... : N/A
Model and/or type reference : RF-RX002
Standards : FCC Part15.249
ANSI C63.10-2013

This device described above has been tested by BCTC, and the test results show that the equipment under test (EUT) is in compliance with the FCC requirements. And it is applicable only to the tested sample identified in the report.

This report shall not be reproduced except in full, without the written approval of BCTC, this document may be altered or revised by BCTC, personal only, and shall be noted in the revision of the document.

Testing Engineer : _____
Sky Huang
Sky Huang

Reviewer (Supervisor) : _____
Jade Yang
Jade Yang

Approved & Authorized Signer(Manager): _____

Carson Zhang
Carson Zhang



Table of Contents

	Page
1 . SUMMARY OF TEST RESULTS	5
1.1 TEST FACILITY	5
1.2 MEASUREMENT UNCERTAINTY	5
2 . GENERAL INFORMATION	6
2.1 GENERAL DESCRIPTION OF EUT	6
2.2 DESCRIPTION OF TEST MODES	7
2.3 BLOCK DIGRAM SHOWING THE CONFIGURATION OF SYSTEM TESTED	8
2.4 DESCRIPTION OF SUPPORT UNITS(CONDUCTED MODE)	8
2.5 EQUIPMENTS LIST FOR ALL TEST ITEMS	9
3 . EMC EMISSION TEST	10
3.1 CONDUCTED EMISSION MEASUREMENT	10
3.1.1 POWER LINE CONDUCTED EMISSION LIMITS	10
3.1.2 TEST PROCEDURE	10
3.1.3 DEVIATION FROM TEST STANDARD	10
3.1.4 TEST SETUP	11
3.1.5 EUT OPERATING CONDITIONS	11
3.1.6 TEST RESULTS	11
3.2 RADIATED EMISSION MEASUREMENT	14
3.2.1 RADIATED EMISSION LIMITS	14
3.2.2 TEST PROCEDURE	15
3.2.3 DEVIATION FROM TEST STANDARD	15
3.2.4 TEST SETUP	15
3.2.5 EUT OPERATING CONDITIONS	16
3.2.6 TEST RESULTS (BETWEEN 9KHZ – 30 MHZ)	17
3.2.7 TEST RESULTS (BETWEEN 30MHZ – 1GHZ)	18
3.2.8 TEST RESULTS (1GHZ~25GHZ)	20
3.3 RADIATED BAND EMISSION MEASUREMENT	21
3.3.1 TEST REQUIREMENT:	21
3.3.2 TEST PROCEDURE	21
3.3.3 DEVIATION FROM TEST STANDARD	22
3.3.4 TEST SETUP	22
3.3.5 EUT OPERATING CONDITIONS	22
4 . BANDWIDTH TEST	24
4.1 APPLIED PROCEDURES / LIMIT	24



Table of Contents

	Page
4.1.1 TEST PROCEDURE	24
4.1.2 DEVIATION FROM STANDARD	24
4.1.3 TEST SETUP	24
4.1.4 EUT OPERATION CONDITIONS	24
4.1.5 TEST RESULTS	25
5 . ANTENNA REQUIREMENT	27
5.1 STANDARD REQUIREMENT	27
5.2 EUT ANTENNA	27
6 . TEST SEUUP PHOTO	28
7 . EUT PHOTO	30



1. SUMMARY OF TEST RESULTS

Test procedures according to the technical standards:

FCC Part15 (15.249) , Subpart C			
Standard Section	Test Item	Judgment	Remark
15.207	Conducted Emission	PASS	
15.249	Radiated Spurious Emission	PASS	
15.249	Bandwidth	PASS	
15.205	Band Edge Emission	PASS	
15.203	Antenna Requirement	PASS	

NOTE:

(1) "N/A" denotes test is not applicable in this Test Report

1.1 TEST FACILITY

Shenzhen BCTC Technology Co., Ltd.

Add. : No.101,Yousong Road,Longhua New District, Shenzhen,China

FCC Registered No.: 187086

1.2 MEASUREMENT UNCERTAINTY

The reported uncertainty of measurement $y \pm U$, where expended uncertainty U is based on a standard uncertainty multiplied by a coverage factor of $k=2$, providing a level of confidence of approximately **95** %.

No.	Item	Uncertainty
1	Conducted Emission Test	$\pm 1.38\text{dB}$
2	RF power,conducted	$\pm 0.16\text{dB}$
3	Spurious emissions,conducted	$\pm 0.21\text{dB}$
4	All emissions,radiated(<1G)	$\pm 4.68\text{dB}$
5	All emissions,radiated(>1G)	$\pm 4.89\text{dB}$
6	Temperature	$\pm 0.5^{\circ}\text{C}$
7	Humidity	$\pm 2\%$



2. GENERAL INFORMATION

2.1 GENERAL DESCRIPTION OF EUT

Equipment	USB RF Receiver	
Trademark	N/A	
Model Name	RF-RX002	
Model Difference	N/A	
Product Description	The EUT is a USB RF Receiver	
	Operation Frequency:	2407~2477MHz
	Modulation Type:	GFSK
	Bit Rate of Transmitter	1Mbps
	Number Of Channel	70 CH
	Antenna type:	internal antenna
	Antenna Gain (dBi)	2.0dBi
	Based on the application, features, or specification exhibited in User's Manual, the EUT is considered as an ITE/Computing Device. More details of EUT technical specification, please refer to the User's Manual.	
Channel List	Please refer to the Note 2.	
Power	DC 5V from USB	
hardware version	--	
Software version	--	
Serial number	--	
Connecting I/O Port(s)	Please refer to the User's Manual	

Note:

1. For a more detailed features description, please refer to the manufacturer's specifications or the User's Manual.



2.

Channel List					
Channel	Frequency (MHz)	Channel	Frequency (MHz)	Channel	Frequency (MHz)
00	2407	27	2434	54	2461
01	2408	28	2435	55	2462
02	2409	29	2436	56	2463
~	~	~	~	~	~
08	2415	35	2442	62	2469
09	2416	36	2443	63	2470
10	2417	37	2447	67	2471
~	~	~	~	~	~
23	2430	50	2457	69	2476
24	2431	51	2458	70	2477
25	2432	52	2459		
26	2433	53	2460		

2.2 DESCRIPTION OF TEST MODES

To investigate the maximum EMI emission characteristics generates from EUT, the test system was pre-scanning tested base on the consideration of following EUT operation mode or test configuration mode which possible have effect on EMI emission level. Each of these EUT operation mode(s) or test configuration mode(s) mentioned above was evaluated respectively.

Pretest Mode	Description
Mode 1	CH00
Mode 2	CH28
Mode 3	CH70
Mode 4	Link Mode
For Conducted & Radiated Emission	
Final Test Mode	Description
Mode 1	CH00
Mode 2	CH28
Mode 3	CH70
Mode 4	Link Mode

Note:

- (1) The measurements are performed at the highest, middle, lowest available channels.
- (2) The measurements are performed at all Bit Rate of Transmitter, the worst data was reported



2.3 BLOCK DIGRAM SHOWING THE CONFIGURATION OF SYSTEM TESTED

Emission Test

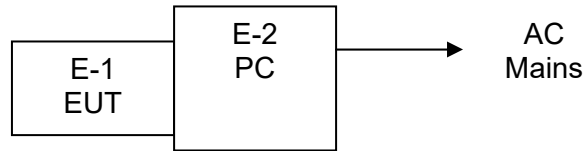

2.4 DESCRIPTION OF SUPPORT UNITS(CONDUCTED MODE)

The EUT has been tested as an independent unit together with other necessary accessories or support units. The following support units or accessories were used to form a representative test configuration during the tests.

Item	Equipment	Mfr/Brand	Model/Type No.	Series No.	Note
E-1	USB RF Receiver	N/A	RF-RX002	N/A	EUT
E-2	PC	ASUS	AWT8000		

Item	Shielded Type	Ferrite Core	Length	Note

Note:

- (1) The support equipment was authorized by Declaration of Confirmation.
- (2) For detachable type I/O cable should be specified the length in cm in 『Length』 column.



2.5 EQUIPMENTS LIST FOR ALL TEST ITEMS

Radiation Test equipment

Item	Kind of Equipment	Manufacturer	Type No.	Serial No.	Last calibration	Calibrated until
1	Spectrum Analyzer	Agilent	E4407B	MY45109572	2015.08.25	2016.08.24
2	Test Receiver	R&S	ESPI	101396	2015.08.25	2016.08.24
3	Bilog Antenna	SCHWARZBECK	VULB9160	VULB9160-3369	2015.08.25	2016.08.24
4	50Ω Coaxial Switch	Anritsu	MP59B	6200264416	2015.07.06	2016.07.05
5	Spectrum Analyzer	Agilent	N9020A	MY5051041	2015.07.06	2016.07.05
6	Horn Antenna	SCHWARZBECK	9120D	9120D-1275	2015.08.25	2016.08.24
7	Horn Ant	Schwarzbeck	BBHA 9170	9170-181	2015.07.06	2016.07.05
8	Amplifier	SCHWARZBECK	BBV9718	9718-270	2015.08.25	2016.08.24
9	Amplifier	SCHWARZBECK	BBV9743	9743-119	2015.08.25	2016.08.24
10	Loop Antenna	ARA	PLRF-RX00230/B	1029	2015.07.06	2016.07.05
11	Power Meter	R&S	NRVS	100696	2015.07.06	2016.07.05
12	Power Sensor	R&S	URV5-Z4	0395.1619.05	2015.07.06	2016.07.05
13	RF cables	R&S	N/A	N/A	2015.07.06	2016.07.05



3. EMC EMISSION TEST

3.1 CONDUCTED EMISSION MEASUREMENT

3.1.1 POWER LINE CONDUCTED EMISSION Limits (Frequency Range 150KHz-30MHz)

FREQUENCY (MHz)	Class A (dBuV)		Class B (dBuV)		Standard
	Quasi-peak	Average	Quasi-peak	Average	
0.15 -0.5	79.00	66.00	66 - 56 *	56 - 46 *	FCC
0.50 -5.0	73.00	60.00	56.00	46.00	FCC
5.0 -30.0	73.00	60.00	60.00	50.00	FCC

Note:

- (1) The tighter limit applies at the band edges.
- (2) The limit of " * " marked band means the limitation decreases linearly with the logarithm of the frequency in the range.

The following table is the setting of the receiver

Receiver Parameters	Setting
Attenuation	10 dB
Start Frequency	0.15 MHz
Stop Frequency	30 MHz
IF Bandwidth	9 kHz

3.1.2 TEST PROCEDURE

- a. The EUT was placed 0.8 meters from the horizontal ground plane with EUT being connected to the power mains through a line impedance stabilization network (LISN). All other support equipments powered from additional LISN(s). The LISN provide 50 Ohm/ 50uH of coupling impedance for the measuring instrument.
- b. Interconnecting cables that hang closer than 40 cm to the ground plane shall be folded back and forth in the center forming a bundle 30 to 40 cm long.
- c. I/O cables that are not connected to a peripheral shall be bundled in the center. The end of the cable may be terminated, if required, using the correct terminating impedance. The overall length shall not exceed 1 m.
- d. LISN at least 80 cm from nearest part of EUT chassis.
- e. For the actual test configuration, please refer to the related Item –EUT Test Photos.

3.1.3 DEVIATION FROM TEST STANDARD

No deviation

3.1.4 TEST SETUP

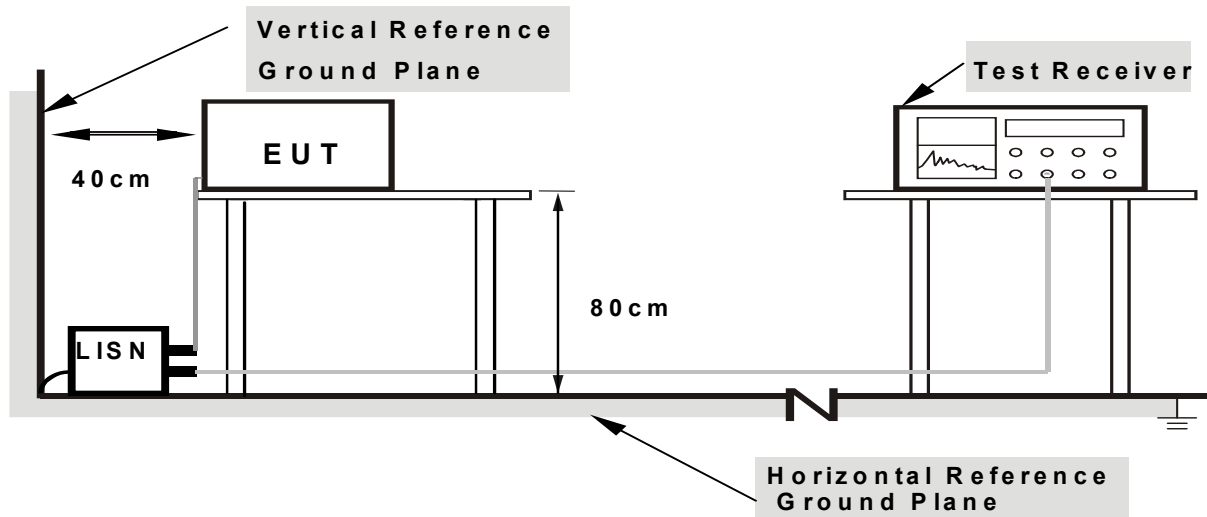

Note: 1.Support units were connected to second LISN .

2.Both of LISNs (AMN) are 80 cm from EUT and at least 80 cm from other units and other metal planes

3.1.5 EUT OPERATING CONDITIONS

The EUT was configured for testing in a typical fashion (as a customer would normally use it). The EUT has been programmed to continuously transmit during test. This operating condition was tested and used to collect the included data.

3.1.6 TEST RESULTS



Temperature :	25 °C	Relative Humidity :	54%
Pressure :	1010hPa	Phase :	L
Test Voltage :	AC 120V/60Hz	Test Mode :	Mode 4

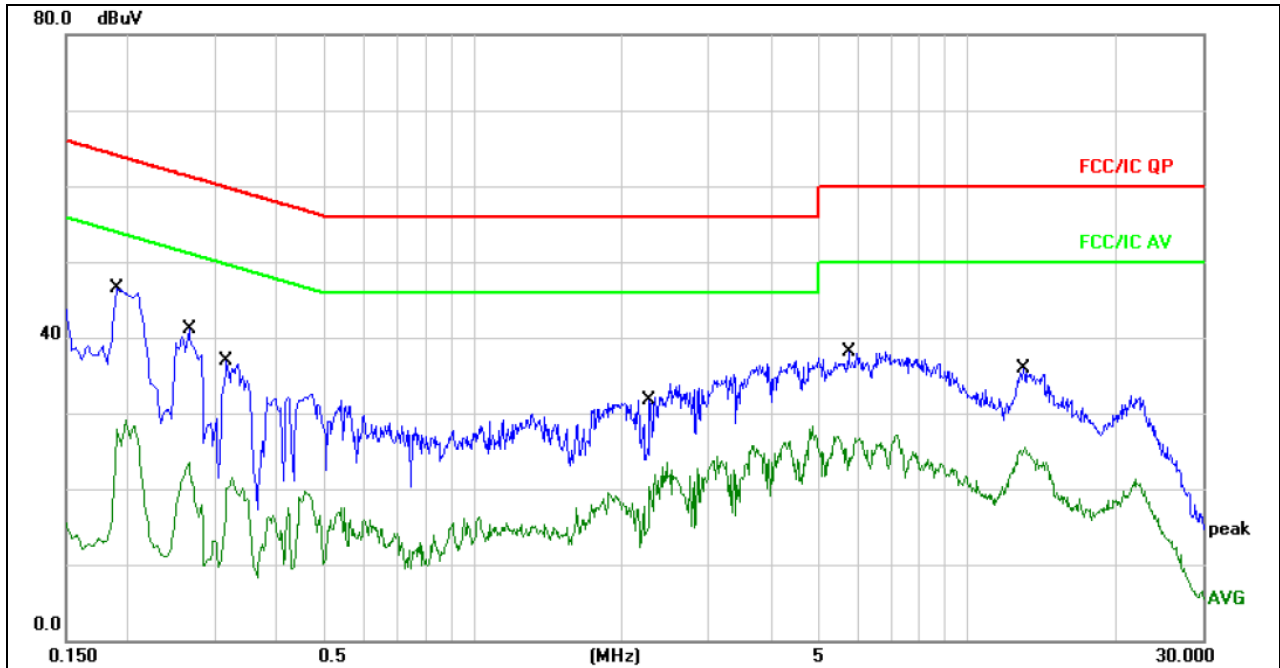

Remark:

1. All readings are Quasi-Peak and Average values.
2. Factor = Insertion Loss + Cable Loss.

No.	Mk.	Freq.	Reading Level	Correct Factor	Measurement	Limit	Over	Detector	Comment
		MHz	dBuV	dB	dBuV	dBuV	dB		
1	*	0.1900	36.42	10.06	46.48	64.03	-17.55	QP	
2		0.1900	17.71	10.06	27.77	54.03	-26.26	AVG	
3		0.2660	31.00	10.09	41.09	61.24	-20.15	QP	
4		0.2660	12.94	10.09	23.03	51.24	-28.21	AVG	
5		0.3180	26.88	10.10	36.98	59.76	-22.78	QP	
6		0.3180	9.99	10.10	20.09	49.76	-29.67	AVG	
7		2.2820	21.53	10.18	31.71	56.00	-24.29	QP	
8		2.2820	10.07	10.18	20.25	46.00	-25.75	AVG	
9		5.7619	27.95	10.10	38.05	60.00	-21.95	QP	
10		5.7619	13.10	10.10	23.20	50.00	-26.80	AVG	
11		13.0140	25.86	10.14	36.00	60.00	-24.00	QP	
12		13.0140	14.27	10.14	24.41	50.00	-25.59	AVG	



Temperature :	25 °C	Relative Humidity :	54%
Pressure :	1010hPa	Phase :	N
Test Voltage :	AC 120V/60Hz	Test Mode :	Mode 4

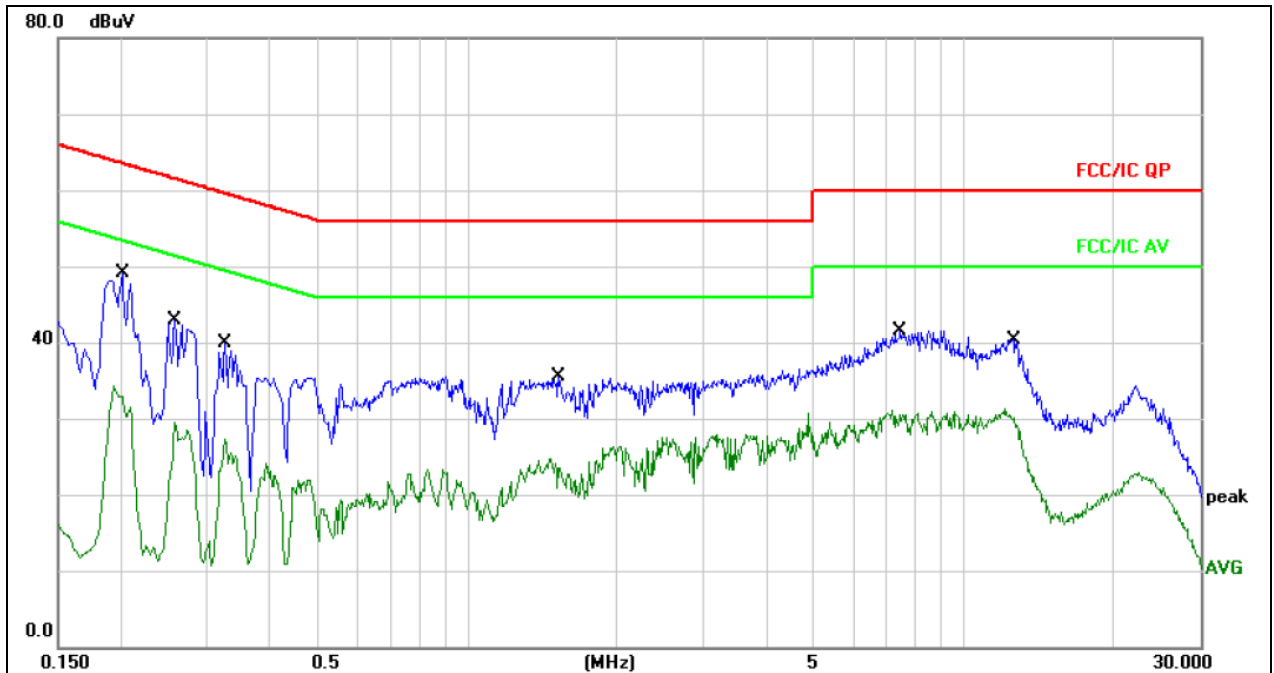

Remark:

1. All readings are Quasi-Peak and Average values.
2. Factor = Insertion Loss + Cable Loss.

No.	Mk.	Freq.	Reading Level	Correct Factor	Measurement	Limit	Over	Detector	Comment
		MHz	dBuV	dB	dBuV	dBuV	dB		
1	*	0.2020	39.03	10.07	49.10	63.52	-14.42	QP	
2		0.2020	22.18	10.07	32.25	53.52	-21.27	AVG	
3		0.2580	32.73	10.08	42.81	61.49	-18.68	QP	
4		0.2580	19.40	10.08	29.48	51.49	-22.01	AVG	
5		0.3260	29.89	10.10	39.99	59.55	-19.56	QP	
6		0.3260	17.25	10.10	27.35	49.55	-22.20	AVG	
7		1.5339	25.28	10.17	35.45	56.00	-20.55	QP	
8		1.5339	13.36	10.17	23.53	46.00	-22.47	AVG	
9		7.4740	31.49	10.10	41.59	60.00	-18.41	QP	
10		7.4740	20.39	10.10	30.49	50.00	-19.51	AVG	
11		12.6100	30.13	10.14	40.27	60.00	-19.73	QP	
12		12.6100	19.81	10.14	29.95	50.00	-20.05	AVG	



3.2 RADIATED EMISSION MEASUREMENT

3.2.1 RADIATED EMISSION LIMITS (Frequency Range 9kHz-1000MHz)

In case the emission fall within the restricted band specified on 15.205(a), then the 15.209(a) limit in the table below has to be followed.

Frequencies (MHz)	Field Strength (micorvolts/meter)	Measurement Distance (meters)
0.009~0.490	2400/F(KHz)	300
0.490~1.705	24000/F(KHz)	30
1.705~30.0	30	30
30~88	100	3
88~216	150	3
216~960	200	3
Above 960	500	3

LIMITS OF RADIATED EMISSION MEASUREMENT (Above 1000MHz)

FREQUENCY (MHz)	Class B (dBuV/m) (at 3M)	
	PEAK	AVERAGE
Above 1000	74	54

Notes:

- (1) The limit for radiated test was performed according to FCC PART 15C.
- (2) The tighter limit applies at the band edges.
- (3) Emission level (dBuV/m)=20log Emission level (uV/m).

Spectrum Parameter	Setting
Attenuation	Auto
Start Frequency	1000 MHz
Stop Frequency	25GHz
RB / VB (emission in restricted band)	1 MHz / 1 MHz for Peak, 1 MHz / 10Hz for Average

Receiver Parameter	Setting
Attenuation	Auto
Start ~ Stop Frequency	9kHz~150kHz / RB 200Hz for QP
Start ~ Stop Frequency	150kHz~30MHz / RB 9kHz for QP
Start ~ Stop Frequency	30MHz~1000MHz / RB 120kHz for QP

3.2.2 TEST PROCEDURE

Below 1GHz test procedure as below:

- The EUT was placed on the top of a rotating table 0.8 meters above the ground at a 3 meter semi-anechoic chamber. The table was rotated 360 degrees to determine the position of the highest radiation.
- The EUT was set 3 meters away from the interference-receiving antenna, which was mounted on the top of a variable-height antenna tower.
- The antenna height is varied from one meter to four meters above the ground to determine the maximum value of the field strength. Both horizontal and vertical polarizations of the antenna are set to make the measurement.
- For each suspected emission, the EUT was arranged to its worst case and then the antenna was tuned to heights from 1 meter to 4 meters (for the test frequency of below 30MHz, the antenna was tuned to heights 1 meter) and the rotatable table was turned from 0 degrees to 360 degrees to find the maximum reading.
- The test-receiver system was set to Peak Detect Function and Specified Bandwidth with Maximum Hold Mode.
- If the emission level of the EUT in peak mode was 10dB lower than the limit specified, then testing could be stopped and the peak values of the EUT would be reported. Otherwise the emissions that did not have 10dB margin would be re-tested one by one using peak, quasi-peak or average method as specified and then reported in a data sheet.

Above 1GHz test procedure as below:

- Different between above is the test site, change from Semi-Anechoic Chamber to fully Anechoic Chamber and change from table 0.8 metre to 1.5 metre (Above 18GHz the distance is 1 meter and table is 1.5 metre).
- Test the EUT in the lowest channel, the middle channel, the Highest channel

Note:

Both horizontal and vertical antenna polarities were tested and performed pretest to three orthogonal axis. The worst case emissions were reported

3.2.3 DEVIATION FROM TEST STANDARD

No deviation

3.2.4 TEST SETUP

(A) Radiated Emission Test-Up Frequency Below 30MHz

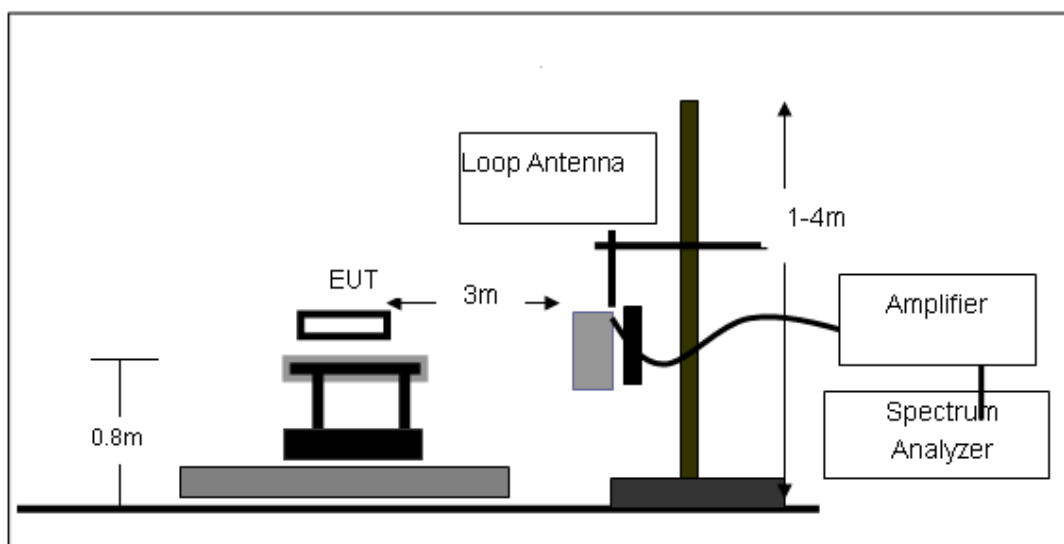

(B) Radiated Emission Test-Up Frequency 30MHz~1GHz

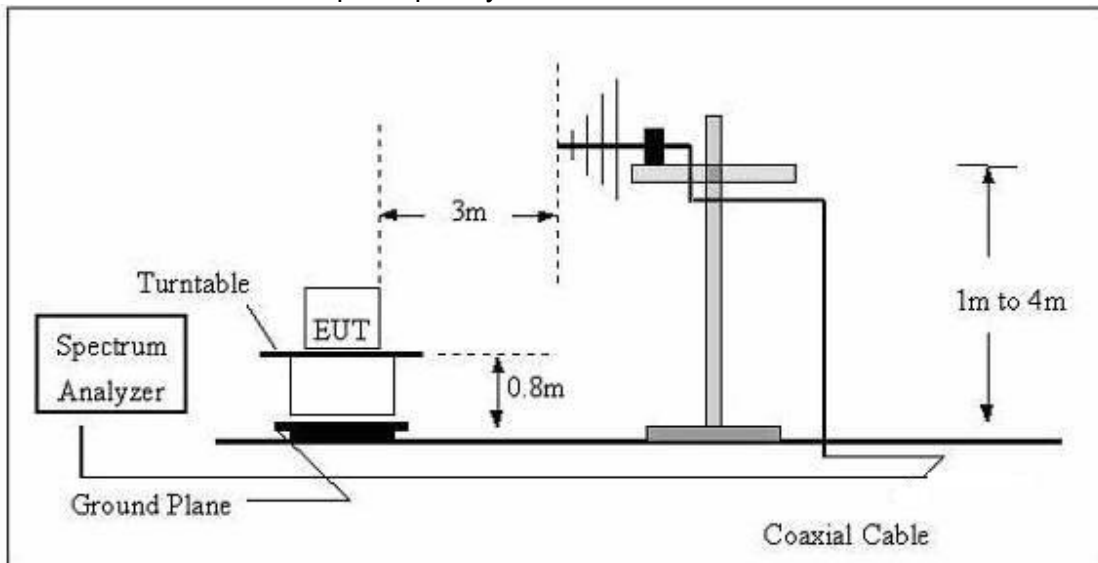

(C) Radiated Emission Test-Up Frequency Above 1GHz

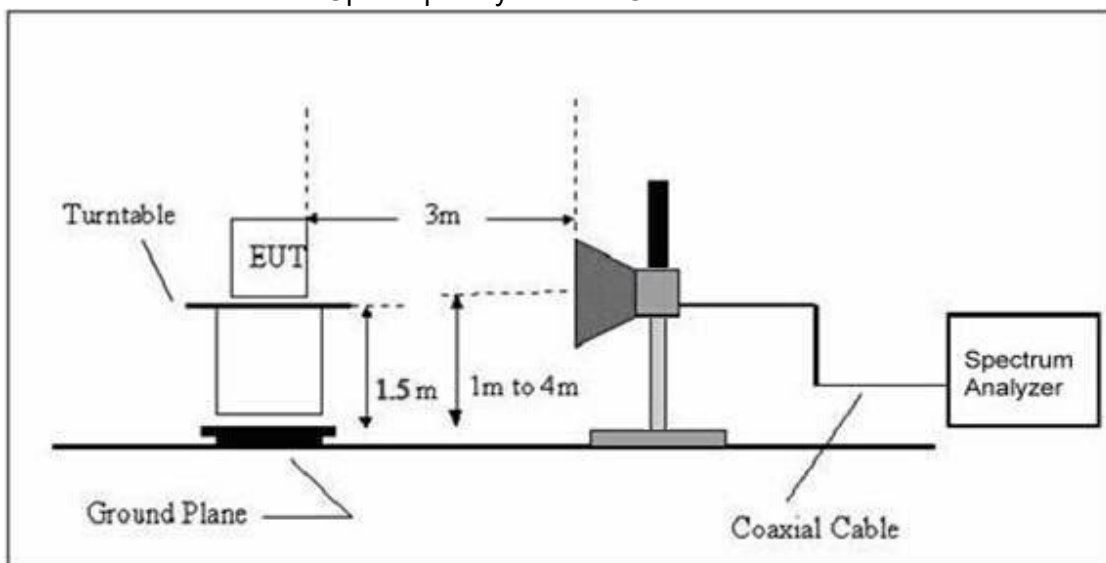

3.2.5 EUT OPERATING CONDITIONS

The EUT tested system was configured as the statements of 2.3 Unless otherwise a special operating condition is specified in the follows during the testing.

**3.2.6 TEST RESULTS (BETWEEN 9KHZ – 30 MHZ)**

Temperature:	20°C	Relative Humidity:	48%
Pressure:	1010 hPa	Test Voltage :	DC 3V
Test Mode :	Mode 4	Polarization :	--

Freq. (MHz)	Reading (dBuV/m)	Limit (dBuV/m)	Margin (dB)	State P/F
--	--	--	--	PASS
--	--	--	--	PASS

NOTE:

The amplitude of spurious emissions which are attenuated by more than 20dB below the permissible value has no need to be reported.

Distance extrapolation factor = $40 \log(\text{specific distance}/\text{test distance})$ (dB);

Limit line = specific limits(dBuv) + distance extrapolation factor.



3.2.7 TEST RESULTS (BETWEEN 30MHZ – 1GHZ)

Temperature :	26°C	Relative Humidity :	54%
Pressure :	1010 hPa	Polarization :	Horizontal
Test Voltage :	DC 3V		
Test Mode :	Mode 4		

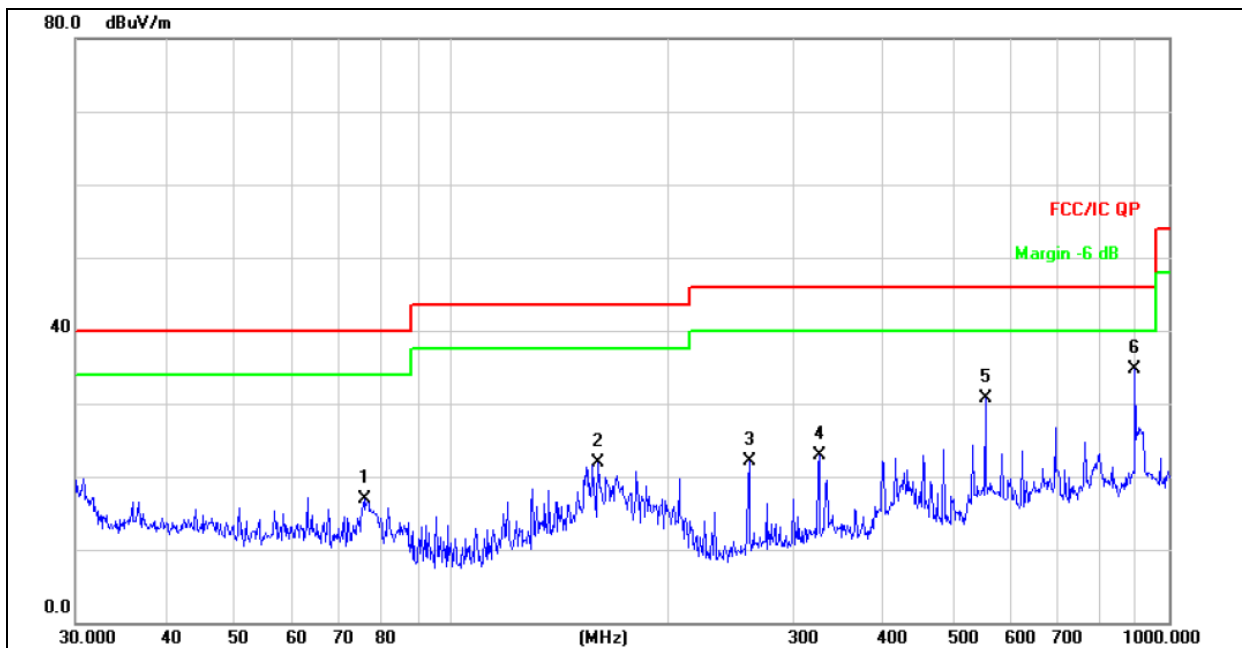

Remark:
Factor = Antenna Factor + Cable Loss – Pre-amplifier.

No.	Mk.	Freq.	Reading Level	Correct Factor	Measurement	Limit	Over	Antenna Height	Table Degree	
		MHz	dBuV	dB/m	dBuV/m	dBuV/m	dB	cm	degree	Comment
1		75.7114	33.52	-16.58	16.94	40.00	-23.06	QP		
2		160.3456	34.87	-12.89	21.98	43.50	-21.52	QP		
3		260.1444	36.10	-13.91	22.19	46.00	-23.81	QP		
4		325.5958	34.90	-11.92	22.98	46.00	-23.02	QP		
5		554.8254	37.62	-6.96	30.66	46.00	-15.34	QP		
6	*	896.9965	36.10	-1.48	34.62	46.00	-11.38	QP		



Temperature :	26°C	Relative Humidity :	54%
Pressure :	1010 hPa	Polarization :	Vertical
Test Voltage :	DC 3V		
Test Mode :	Mode 4		

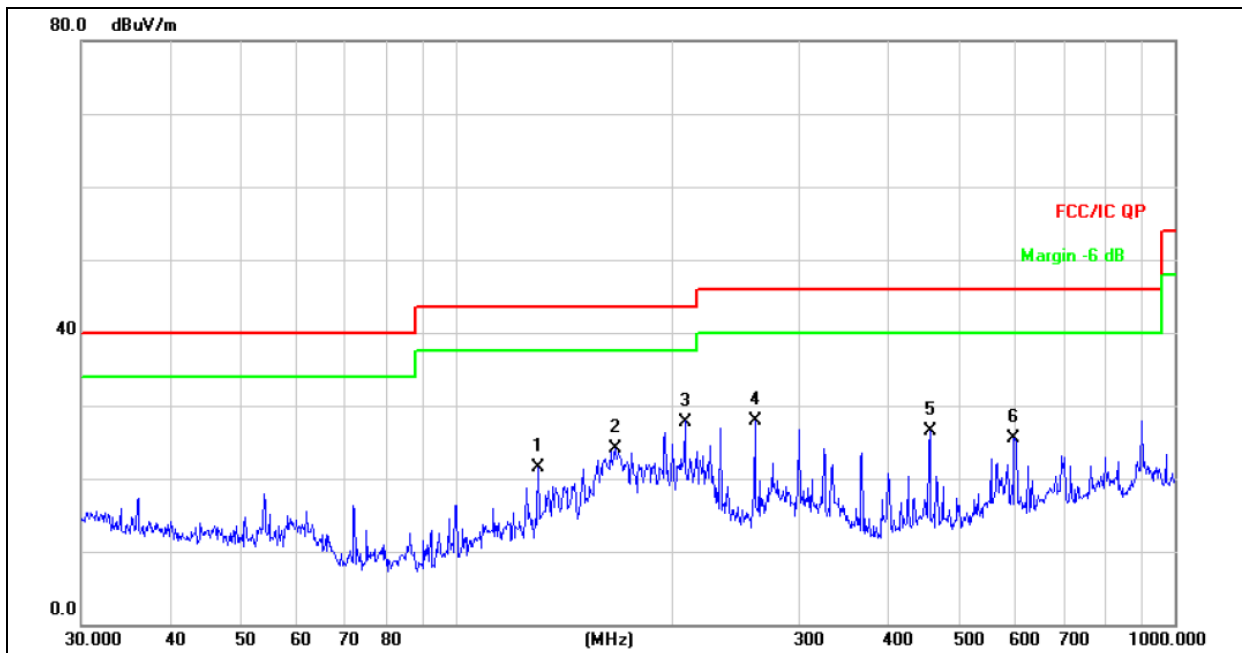

Remark:
Factor = Antenna Factor + Cable Loss – Pre-amplifier.

No.	Mk.	Freq.	Reading Level	Correct Factor	Measurement	Limit	Over	Antenna Height	Table Degree	
		MHz	dBuV	dB/m	dBuV/m	dBuV/m	dB	cm	degree	Comment
1		129.9226	35.53	-14.11	21.42	43.50	-22.08	QP		
2		166.0680	37.28	-13.23	24.05	43.50	-19.45	QP		
3	*	207.8501	43.78	-15.98	27.80	43.50	-15.70	QP		
4		260.1444	41.84	-13.91	27.93	46.00	-18.07	QP		
5		455.9058	35.42	-8.92	26.50	46.00	-19.50	QP		
6		597.2233	31.37	-5.77	25.60	46.00	-20.40	QP		



3.2.8 TEST RESULTS (1GHZ~25GHZ)

GFSK

Polar (H/V)	Frequency	Meter Reading	Factor	Emission Level	Limits	Margin	Detector Type
	(MHz)	(dBUV)	(dB)	(dBUV/m)	(dBUV/m)	(dB)	
operation frequency:2407							
V	2407.00	87.13	13.85	100.98	114.00	-13.02	PK
V	2407.00	72.02	13.85	85.87	94.00	-8.13	AV
V	4814.00	38.94	19.34	58.28	74.00	-15.72	PK
V	4814.00	25.45	19.34	44.79	54.00	-9.21	AV
V	16130.00	29.61	21.89	51.50	74.00	-22.50	PK
H	2407.00	87.10	13.85	100.95	114.00	-13.05	PK
H	2407.00	72.62	13.85	86.47	94.00	-7.53	AV
H	4814.00	39.76	19.34	59.10	74.00	-14.90	PK
H	4814.00	25.34	19.34	44.68	54.00	-9.32	AV
H	16130.00	29.36	21.89	51.25	74.00	-22.75	PK
operation frequency:2435							
V	2435.00	87.62	13.93	101.55	114.00	-12.45	PK
V	2435.00	72.15	13.93	86.08	94.00	-7.92	AV
V	4870.00	39.86	19.41	59.27	74.00	-14.73	PK
V	4870.00	25.49	19.41	44.90	54.00	-9.10	AV
V	16130.00	27.88	21.89	49.77	74.00	-24.23	PK
H	2435.00	87.64	13.93	101.57	114.00	-12.43	PK
H	2435.00	73.03	13.93	86.96	94.00	-7.04	AV
H	4870.00	40.92	19.41	60.33	74.00	-13.67	PK
H	4870.00	26.20	19.41	45.61	54.00	-8.39	AV
H	16130.00	29.53	21.89	51.42	74.00	-22.58	PK

operation frequency:2477							
V	2477.00	87.67	14.02	101.69	114.00	-12.31	PK
V	2477.00	72.25	14.02	86.27	94.00	-7.73	AV
V	4954.00	40.65	19.51	60.16	74.00	-13.84	PK
V	4954.00	25.76	19.51	45.27	54.00	-8.73	AV
V	16130.00	29.74	21.89	51.63	74.00	-22.37	PK
H	2477.00	87.70	14.02	101.72	114.00	-12.28	PK
H	2477.00	72.10	14.02	86.12	94.00	-7.88	AV
H	4954.00	40.87	19.51	60.38	74.00	-13.62	PK
H	4954.00	25.79	19.51	45.30	54.00	-8.70	AV
H	16130.00	30.06	21.89	51.95	74.00	-22.05	PK

Remark:

1. Emission Level = Meter Reading + Factor, Margin= Emission Level - Limit
2. If peak below the average limit, the average emission was no test.
3. The amplitude of spurious emissions which are attenuated by more than 20dB below the permissible value has no need to be reported.



3.3 RADIATED BAND EMISSION MEASUREMENT

3.3.1 TEST REQUIREMENT:

FCC Part15 C Section 15.209 and 15.205

LIMITS OF RADIATED EMISSION MEASUREMENT (Above 1000MHz)

FREQUENCY (MHz)	Class B (dBuV/m) (at 3M)	
	PEAK	AVERAGE
Above 1000	74	54

Notes:

- (1) The limit for radiated test was performed according to FCC PART 15C.
- (2) The tighter limit applies at the band edges.
- (3) Emission level (dBuV/m)=20log Emission level (uV/m).

Spectrum Parameter	Setting
Attenuation	Auto
Start Frequency	2300MHz
Stop Frequency	2520
RB / VB (emission in restricted band)	1 MHz / 1 MHz for Peak, 1 MHz / 10Hz for Average

3.3.2 TEST PROCEDURE

Above 1GHz test procedure as below:

- a. 1. The EUT was placed on the top of a rotating table 1.5 meters above the ground at a 3 meter camber. The table was rotated 360 degrees to determine the position of the highest radiation.
- b. The EUT was set 3 meters away from the interference-receiving antenna, which was mounted on the top of a variable-height antenna tower.
- c. The antenna height is varied from one meter to four meters above the ground to determine the maximum value of the field strength. Both horizontal and vertical polarizations of the antenna are set to make the measurement.
- d. For each suspected emission, the EUT was arranged to its worst case and then the antenna was tuned to heights from 1 meter to 4 meters and the rota table was turned from 0 degrees to 360 degrees to find the maximum reading.
- e. The test-receiver system was set to Peak Detect Function and Specified Bandwidth with Maximum Hold Mode.
- f. If the emission level of the EUT in peak mode was 10dB lower than the limit specified, then testing could be stopped and the peak values of the EUT would be reported. Otherwise the emissions that did not have 10dB margin would be re-tested one by one using peak, quasi-peak or average method as specified and then reported in a data sheet.
- g. Test the EUT in the lowest channel,the Highest channel

Note:

Both horizontal and vertical antenna polarities were tested and performed pretest to three orthogonal axis. The worst case emissions were reported

3.3.3 DEVIATION FROM TEST STANDARD

No deviation

3.3.4 TEST SETUP

Radiated Emission Test-Up Frequency Above 1GHz

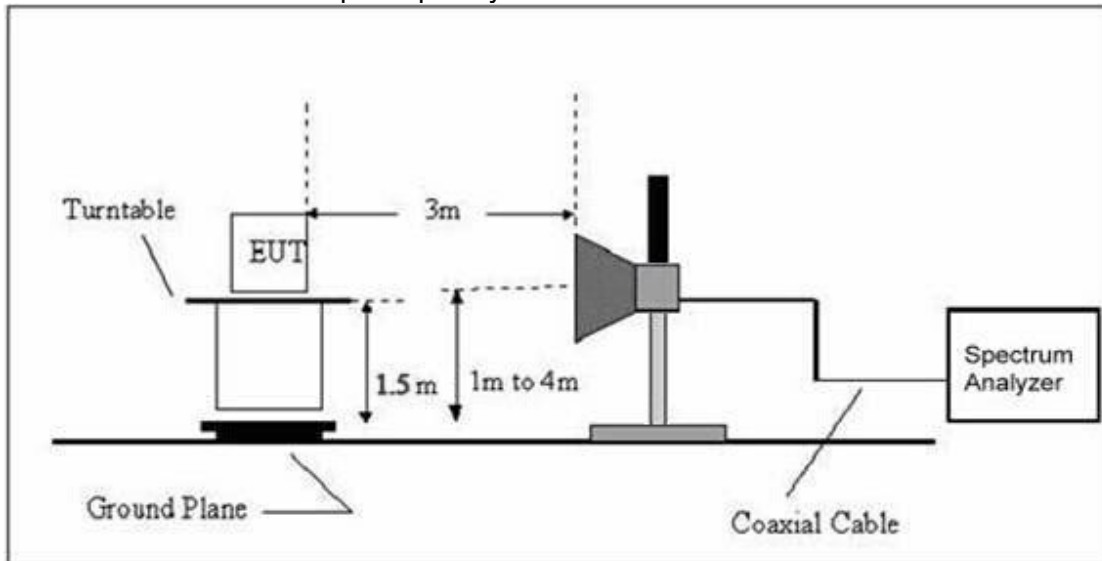

3.3.5 EUT OPERATING CONDITIONS

The EUT tested system was configured as the statements of 2.3 Unless otherwise a special operating condition is specified in the follows during the testing.



3.3.6 TEST RESULT

GFSK

Polar (H/V)	Frequency	Meter Reading	Factor	Emission Level	Limits	Margin	Detector Type
	(MHz)	(dBuV)	(dB)	(dBuV/m)	(dBuV/m)	(dB)	
operation frequency:2407							
V	2390.00	36.80	13.83	50.63	74.00	-23.37	PK
V	2390.00	25.57	13.83	39.40	54.00	-14.60	AV
V	2400.00	36.99	13.85	50.84	74.00	-23.16	PK
V	2400.00	25.14	13.85	38.99	54.00	-15.01	AV
H	2390.00	37.07	13.83	50.90	74.00	-23.10	PK
H	2390.00	25.60	13.83	39.43	54.00	-14.57	AV
H	2400.00	36.94	13.85	50.79	74.00	-23.21	PK
H	2400.00	25.54	13.85	39.39	54.00	-14.61	AV

Polar (H/V)	Frequency	Meter Reading	Factor	Emission Level	Limits	Margin	Detector Type
	(MHz)	(dBuV)	(dB)	(dBuV/m)	(dBuV/m)	(dB)	
operation frequency:2477							
V	2483.50	36.99	14.02	51.01	74.00	-22.99	PK
V	2483.50	25.81	14.02	39.83	54.00	-14.17	AV
V	2500.00	36.93	14.06	50.99	74.00	-23.01	PK
V	2500.00	25.24	14.06	39.30	54.00	-14.70	AV
H	2483.50	37.11	14.02	51.13	74.00	-22.87	PK
H	2483.50	25.85	14.02	39.87	54.00	-14.13	AV
H	2500.00	36.75	14.06	50.81	74.00	-23.19	PK
H	2500.00	26.08	14.06	40.14	54.00	-13.86	AV

Remark:

1. Emission Level = Meter Reading + Factor, Margin= Emission Level - Limit
2. If peak below the average limit, the average emission was no test.
3. The amplitude of spurious emissions which are attenuated by more than 20dB below the permissible value has no need to be reported.



4. BANDWIDTH TEST

4.1 APPLIED PROCEDURES

FCC Part15 (15.249) , Subpart C		
Section	Test Item	
15.249	Bandwidth	

4.1.1 TEST PROCEDURE

1. Set RBW = 100 kHz.
2. Set the video bandwidth (VBW) $\geq 3 \times$ RBW.
3. Detector = Peak.
4. Trace mode = max hold.
5. Sweep = auto couple.
6. Allow the trace to stabilize.
7. Measure the maximum width of the emission that is constrained by the frequencies associated with the two outermost amplitude points (upper and lower frequencies) that are attenuated by 6 dB relative to the maximum level measured in the fundamental emission.

4.1.2 DEVIATION FROM STANDARD

No deviation.

4.1.3 TEST SETUP



4.1.4 EUT OPERATION CONDITIONS

The EUT tested system was configured as the statements of 2.3 Unless otherwise a special operating condition is specified in the follows during the testing.



4.1.5 TEST RESULTS

Temperature :	25°C	Relative Humidity :	60%
Pressure :	1012 hPa	Test Voltage :	DC 3V
Test Mode :	TX Mode /CH00, CH28, CH70		

	Frequency (MHz)	20dB bandwidth (MHz)
GFSK	2407	0.306
	2435	0.306
	2477	0.312

GFSK

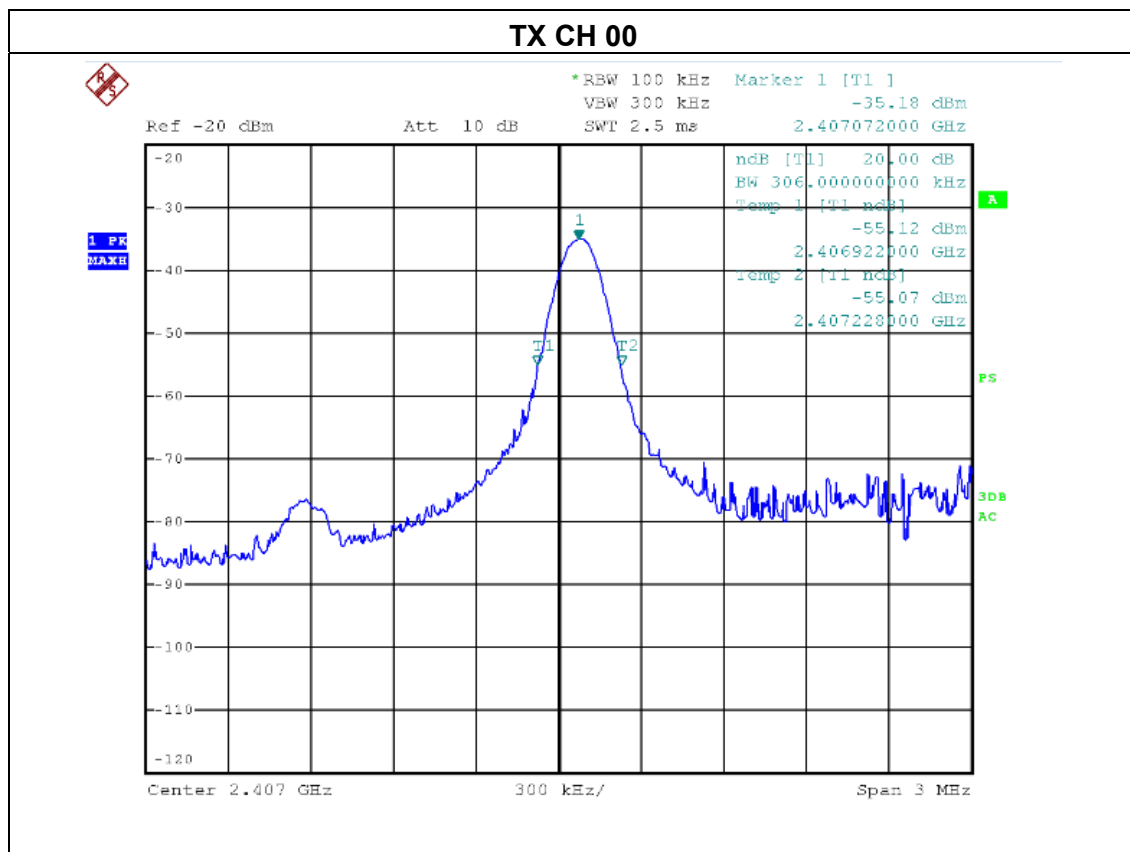

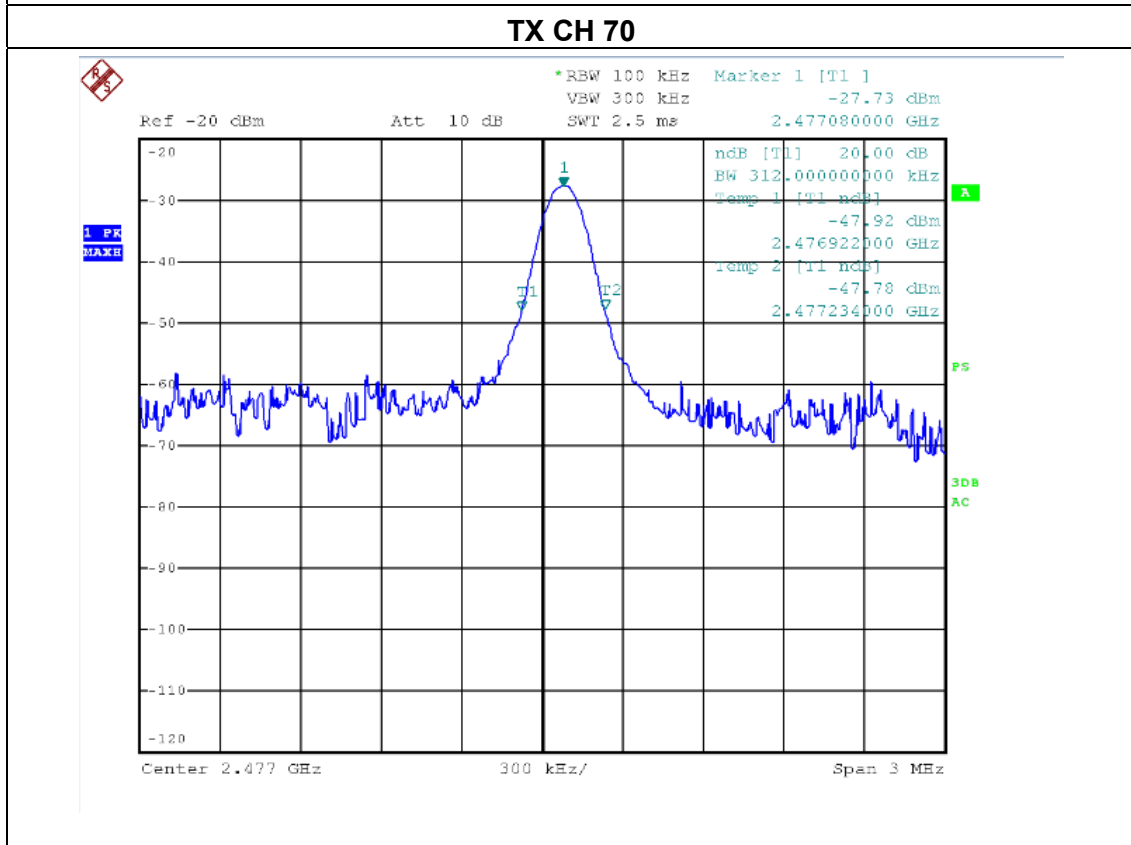
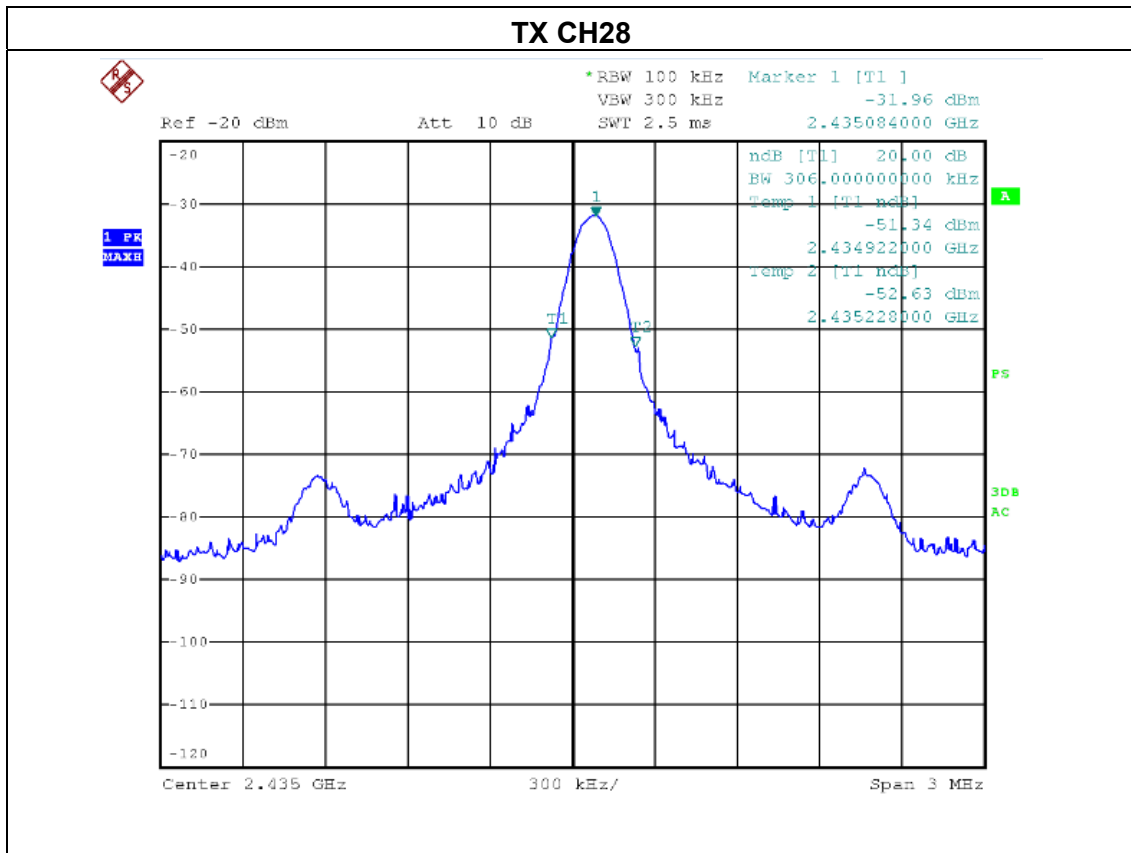



5. ANTENNA REQUIREMENT

5.1 STANDARD REQUIREMENT

15.203 requirement: For intentional device, according to 15.203: an intentional radiator shall be designed to ensure that no antenna other than that furnished by the responsible party shall be used with the device.

5.2 EUT ANTENNA

The EUT antenna is internal antenna,. It comply with the standard requirement.

6. TEST SEUUP PHOTO

Radiated Measurement Photos

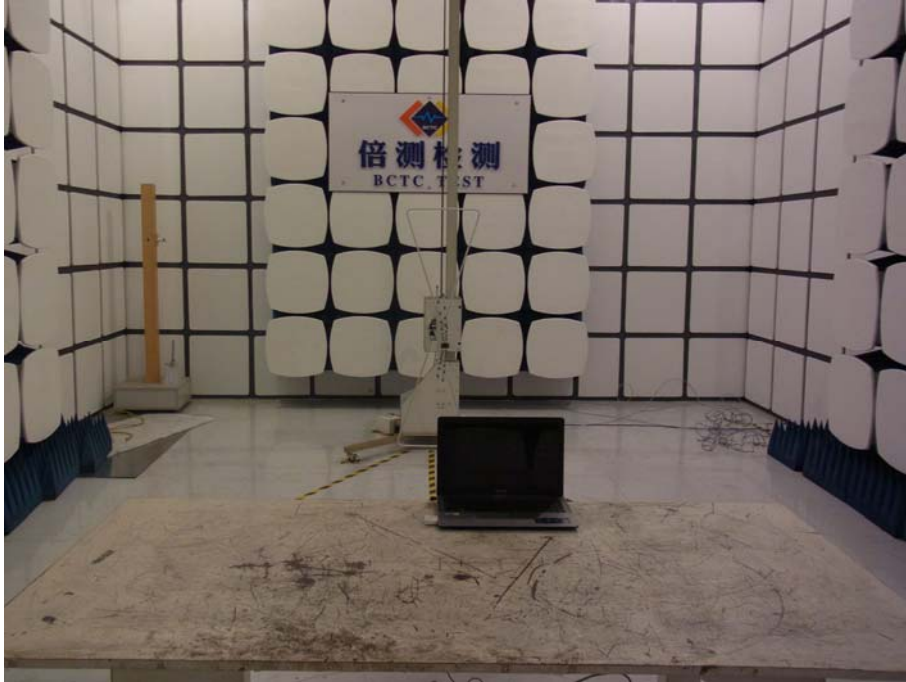



Conducted Measurement Photos



7. EUT PHOTO



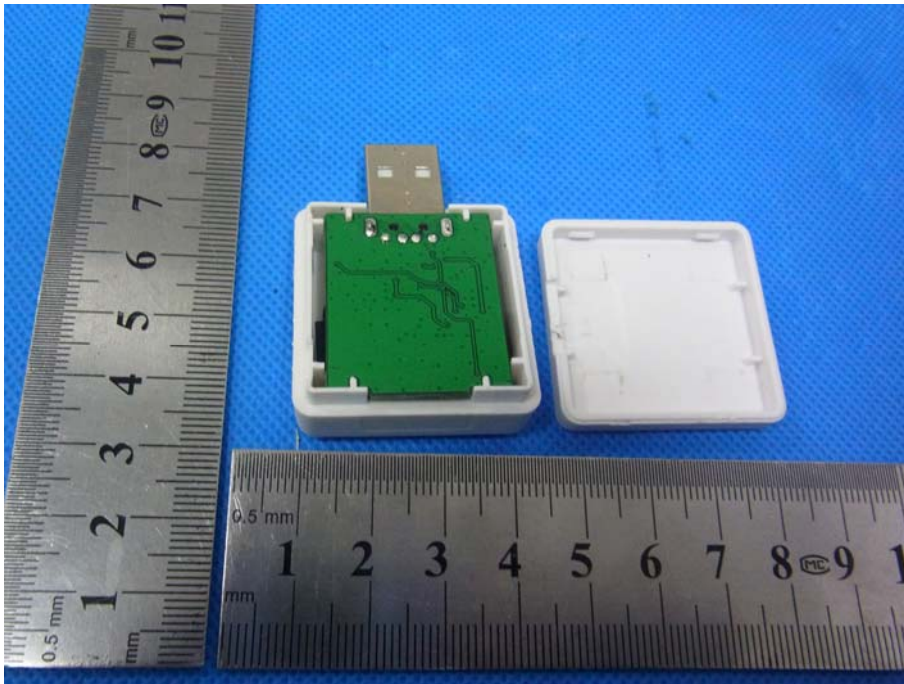

***** END OF REPORT *****