

PMX AUDIO KIT BY ROCKFORD FOSGATE®



P/N 2883964

IMPORTANT

Due to the technical nature of this kit, Polaris® insists this installation be performed by a certified Polaris® Technician.

APPLICATION

Verify accessory fitment at Polaris.com.

BEFORE YOU BEGIN

Read these instructions and check to be sure all parts and tools are accounted for. Please retain these installation instructions for future reference and parts ordering information.

REQUIRED SOLD SEPARATELY

Only parts for installation of the PMX Audio Kit By Rockford Fosgate® are included. For complete installation, the following additional kit is required (sold separately):

- *Base Audio Kit, P/N 2883943*

KIT CONTENTS

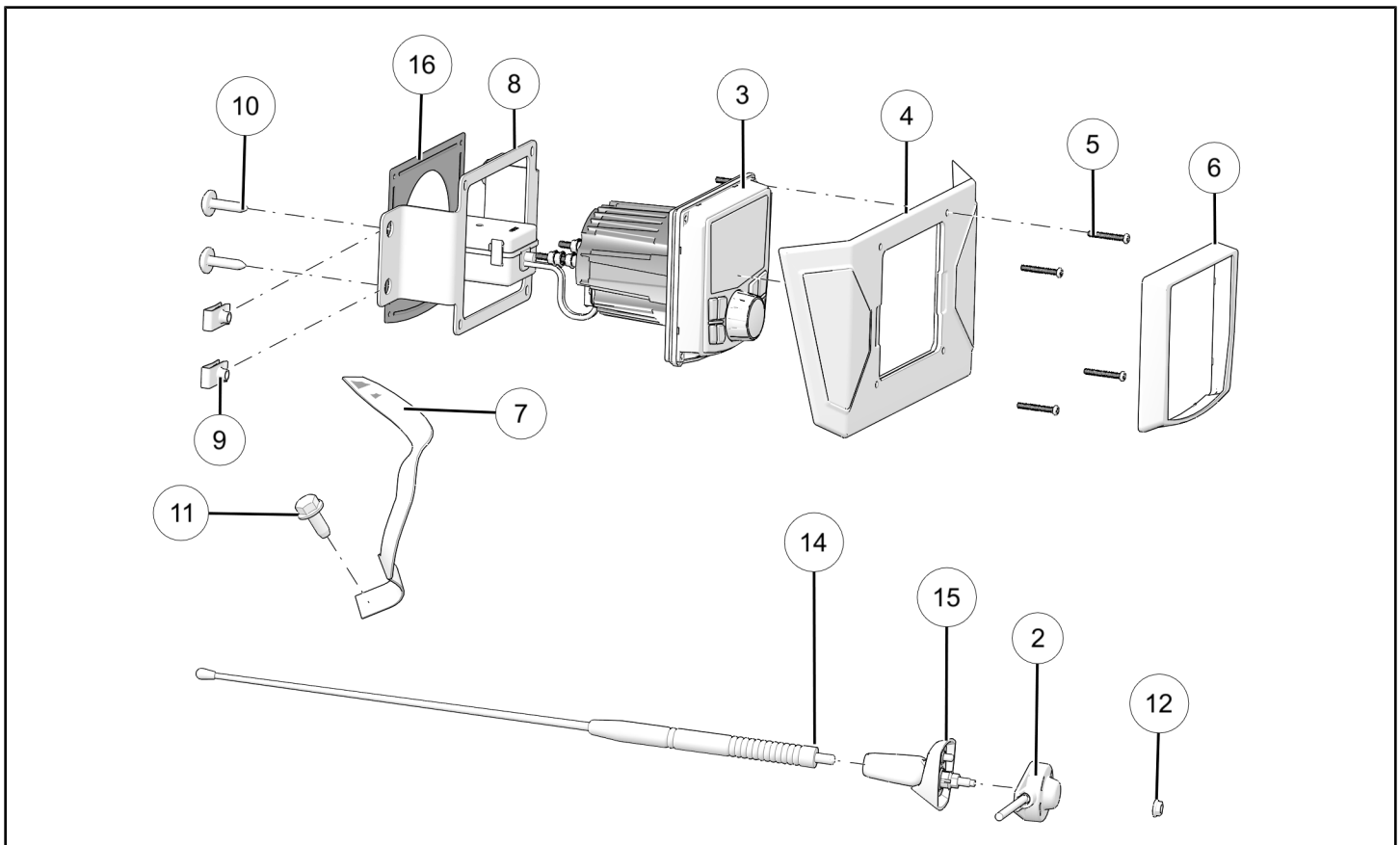

REF	QTY	PART DESCRIPTION	P/N AVAILABLE SEPARATELY
1	1	Harness–Audio, PMX (see <i>Harness Detail</i> section)	2414719
2	1	Assembly–Harness, AM/FM Antenna	2414727
3	1	Assembly–Head Unit, PMX	2637397
4	1	Panel–Cover, 7 in. Display	2637662
5	4	Screw–Hex Button Head, M3.5 x 0.6 mm x 25 mm	n/a
6	1	Cover–PMX, Front	n/a
7	1	Strap–Ground, Antenna, Braided	4016696
8	1	Bracket–PMX, Dashboard	5267727-329
9	4	Clip–U, Speed Nut	7081305
10	4	Screw–Torx® Truss Head, M6 x 1.0 mm x 25 mm	7519650
11	1	Screw–Hex Flange, M8 x 1.25 mm x 20 mm	7520764
12	1	Nut–Hex Flange, M5 x 0.8 mm	7547437
13	2	Cable Tie (not shown)	7081033
14	1	Antenna–Mast, AM/FM, Short	4014849
15	1	Mount–Antenna, 90°	4016695
16	1	Plate–Back, Dashboard Bracket	n/a

HARNESS DETAIL

HARNESS-AUDIO, PMX P/N 2414719

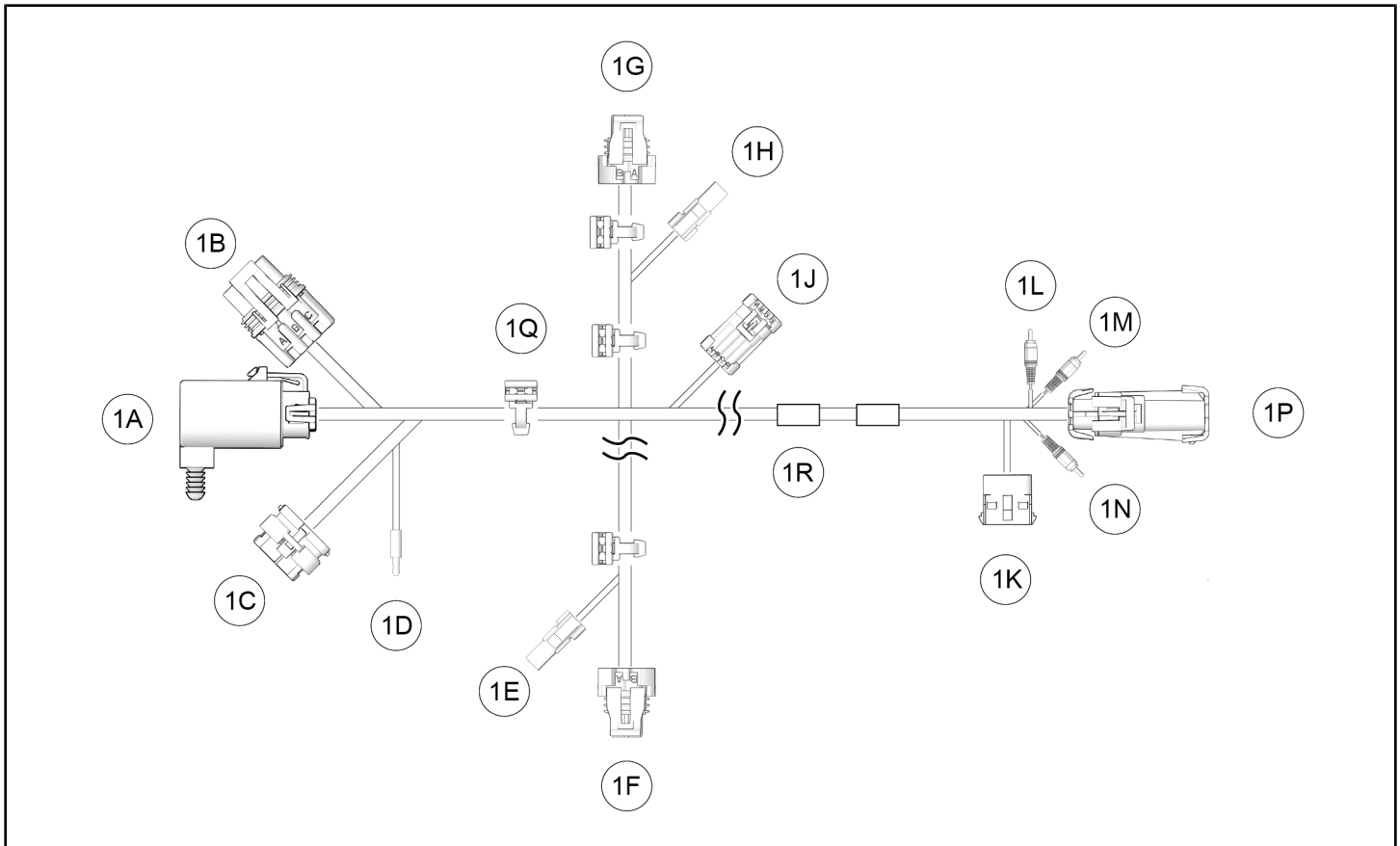

NOTE

Harness Detail graphic is compressed to emphasize detail.

REF	PART DESCRIPTION	PIN QTY / GENDER		CONNECTS TO
1A	Fuse Relay Center	n/a		Vehicle Structure
1B	Connector, Power, Polaris Pulse®	3 Pin Female		Pulse® terminal block
1C	Connector, Amplifier, 4 Channel	23 Pin Female		Amplifier
1D	Bullet Connector, Ground, Amplifier	1 Pin Male		Amplifier
1E	Connector, Front, Tweeter, Right	2 Pin Female		Speaker-Tweeter, Right
1F	Connector, Front, Driver, Right	2 Pin Female		Speaker-Driver, Right
1G	Connector, Front, Driver, Left	2 Pin Female		Speaker-Driver, Left
1H	Connector, Front, Tweeter, Left	2 Pin Female		Speaker-Tweeter, Left
1J	Connector, Audio, Rear	4 Pin	2 Pin Male	Vehicle Structure / Rear Audio

REF	PART DESCRIPTION	PIN QTY / GENDER		CONNECTS TO
			2 Pin Female	
1P	Connector, Subwoofer	8 Pin	4 Pin Male	Harness--Audio, Subwoofer
			4 Pin Female	
1R	Tape (2 Locations)	n/a		Identifies installation location for cable tie ⑬

TOOLS REQUIRED

- Safety Glasses
- Drill
- Drill Bit:
 - 3/16 in. (5 mm)
 - 1/2 in. (12 mm)
- Pliers, Push Pin Rivet
- Screwdriver Set, Torx®
- Socket Set, Torx® Bit
- Torque Wrench

IMPORTANT

Your PMX Audio Kit By Rockford Fosgate® is exclusively designed for your vehicle. Please read the installation instructions thoroughly before beginning. Installation is easier if the vehicle is clean and free of debris. For your safety, and to ensure a satisfactory installation, perform all installation steps correctly in the sequence shown.

INSTALLATION INSTRUCTIONS

VEHICLE PREPARATION

GENERAL

1. Shift vehicle transmission into PARK. Turn key to OFF position and remove from vehicle.

CENTER HOOD PANEL REMOVAL

1. Turn two quarter-turn fasteners to loosen center hood panel. Slide panel backwards until tabs clear front hood panel.

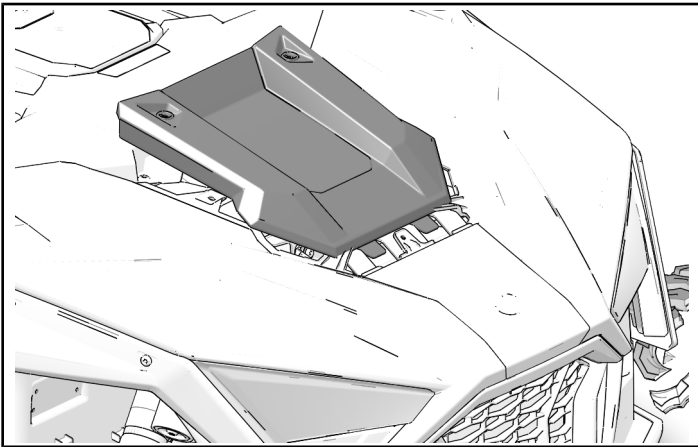

DASHBOARD STORAGE REMOVAL

1. Open center dashboard storage compartment.

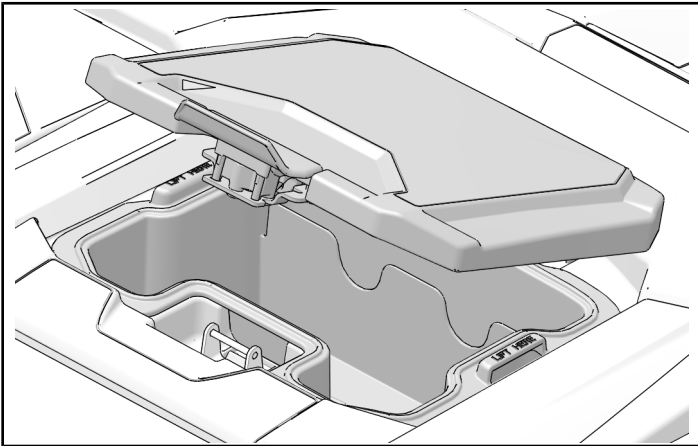

2. Remove storage compartment from dashboard.

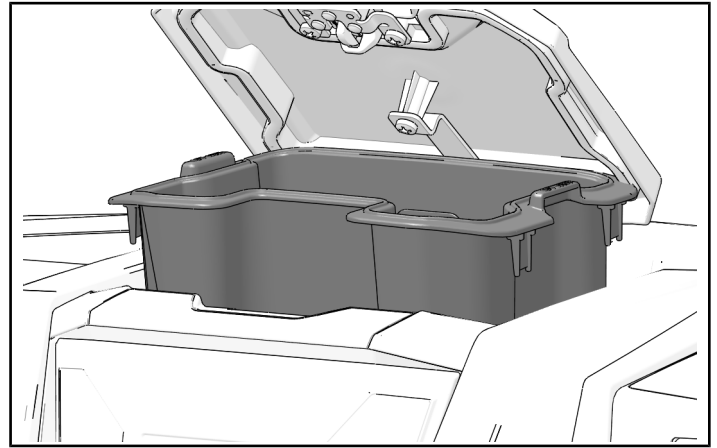

DASHBOARD TOP REMOVAL

1. Carefully pull up to remove and retain left (A), center (B), and right (C) dash trim pieces.

TIP

Release steering tilt lock for better access.

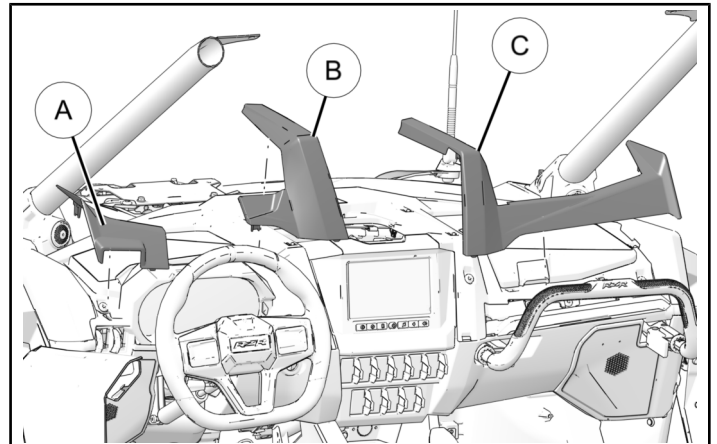

2. Open glove box lid. Remove and retain four screws (E) around glove box opening and three screws (F) from front of dashboard top (D). Make note of different screw sizes.

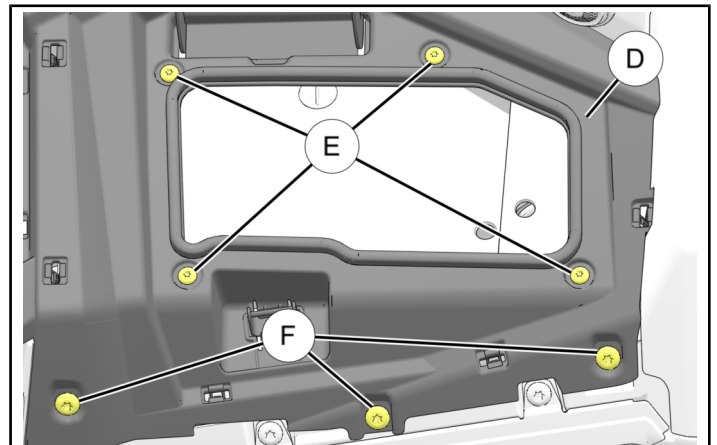

3. Tilt steering wheel down. Remove and retain four screws (E) from dashboard top (D).

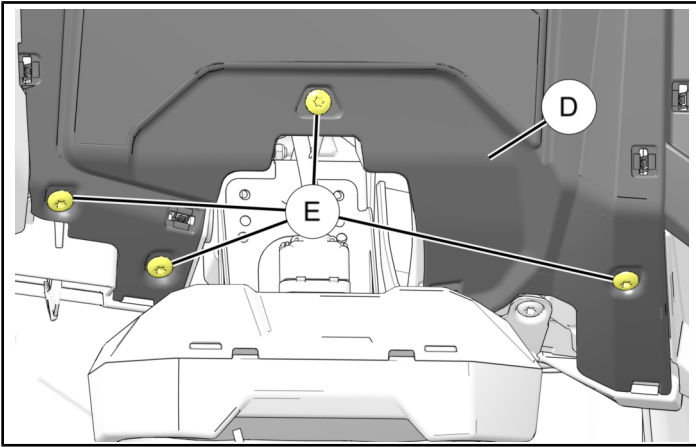

4. On front of vehicle, near rear edge of center hood panel opening, remove and retain two screws (G) from dashboard top (D). Remove and retain two pushpin rivets (H) from front side panels.

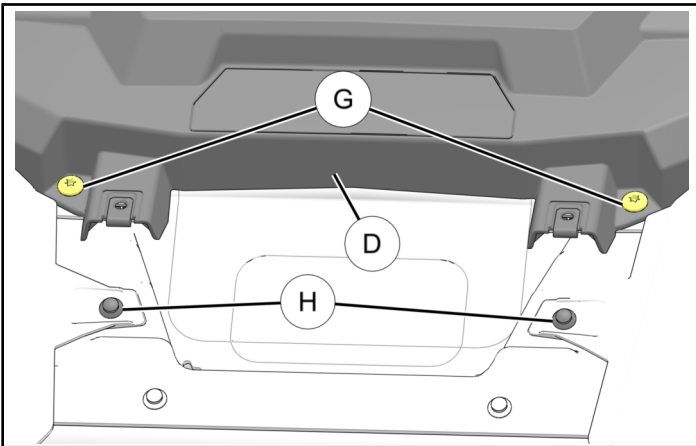

5. Carefully lift edge of left front fender (J) to release tab from dashboard top (D) as shown.

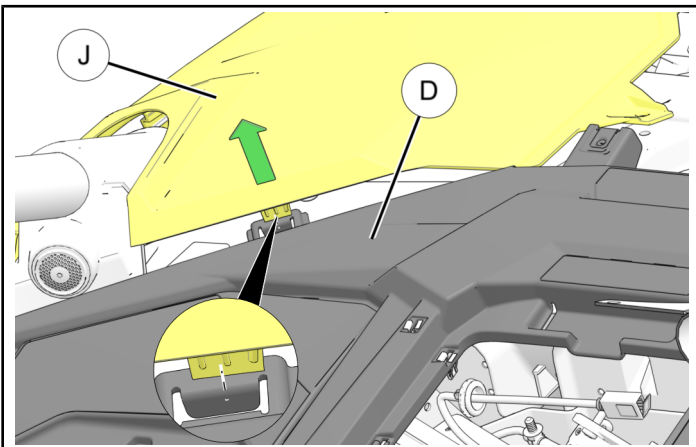

6. Carefully lift edge of right front fender (K) to release tab from dashboard top (D) as shown.

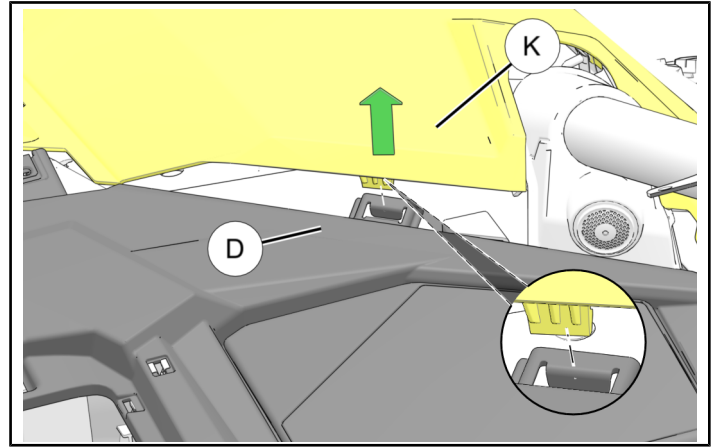

7. Carefully keep panels (J) and (K) up and away from tabs and remove dashboard top (D) by tilting rear section up and pulling out toward rear.

TIP
Have a second person to hold panels up.

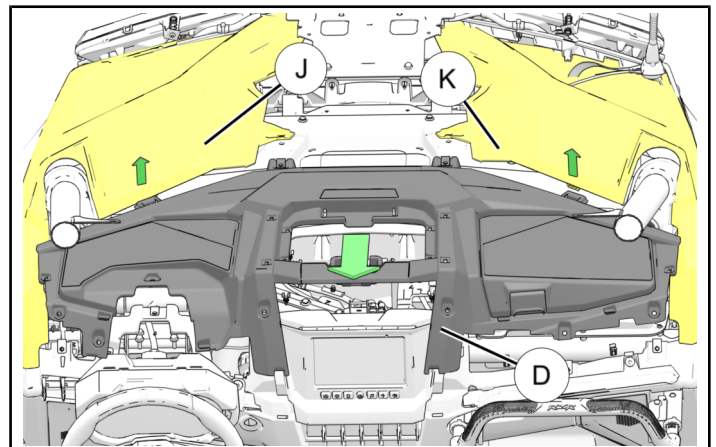

ACCESSORY INSTALLATION

RIGHT-HAND HOOD DISASSEMBLY

TIP

Hood can be disassembled for improved access during installation procedures.

1. Remove and retain one fastener (A) to remove hood nose.

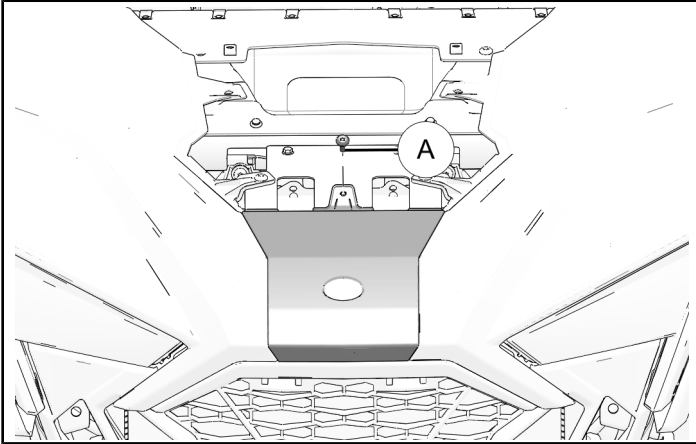

2. Remove and retain three front fender fasteners (A).

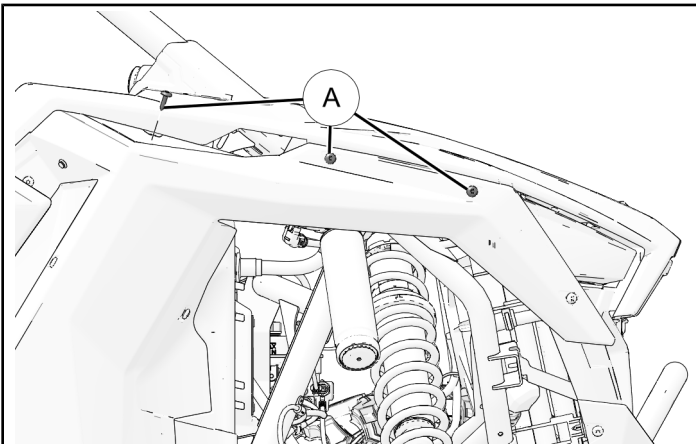

3. Remove and retain one hood fastener (A) and one push-pin rivet (B).

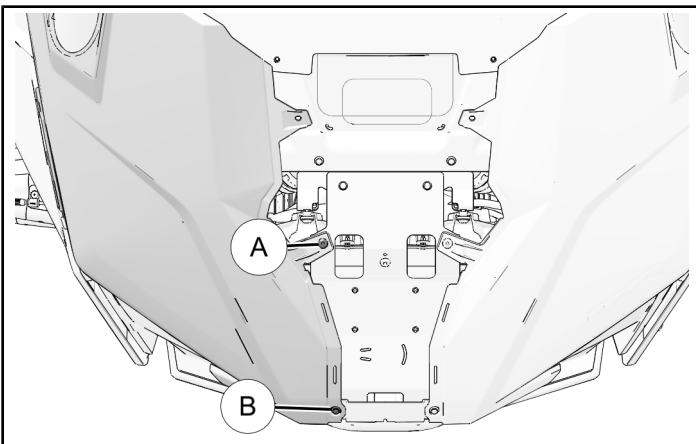

ANTENNA INSTALLATION

HOOD PANEL PREPARATION

1. Mark two holes on top of right front fender for alignment pin and antenna mounting post.

NOTE

Exact location is not critical, however, ensure location allows ground strap to span distance of antenna base to chassis ground location (see step 4 of *Antenna Installation* section for ground strap location). If mast tilt functionality is desired, ensure location allows for tilt.

MEASUREMENT

Antenna Mounting Post hole: 1/2 in. (12 mm)
Alignment Pin hole: 3/16 in. (5 mm)
Ensure distance between center of each hole is 9/16 in. (15 mm), as shown in diagram below.

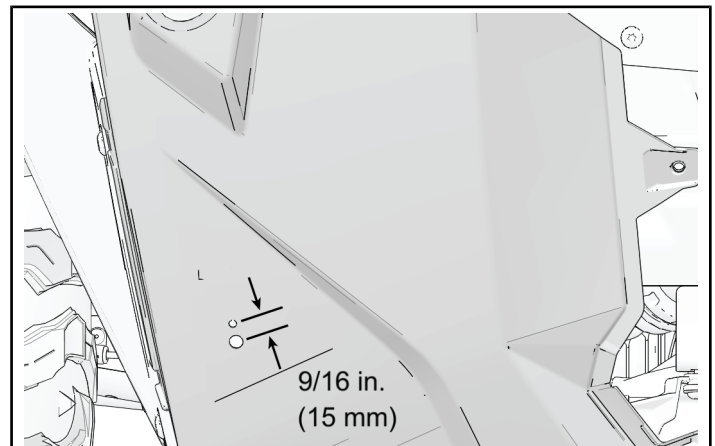

2. Drill at each marked location.

CAUTION

Control drill depth to prevent damage to underlying structure or components.

MEASUREMENT

Antenna Mounting Post hole: 1/2 in. (12 mm)
Alignment Pin hole: 3/16 in. (5 mm)
Ensure distance between center of each hole is 9/16 in. (15 mm), as shown in diagram below.

ANTENNA INSTALLATION

1. Install antenna mast ⑭ onto antenna mount ⑮.

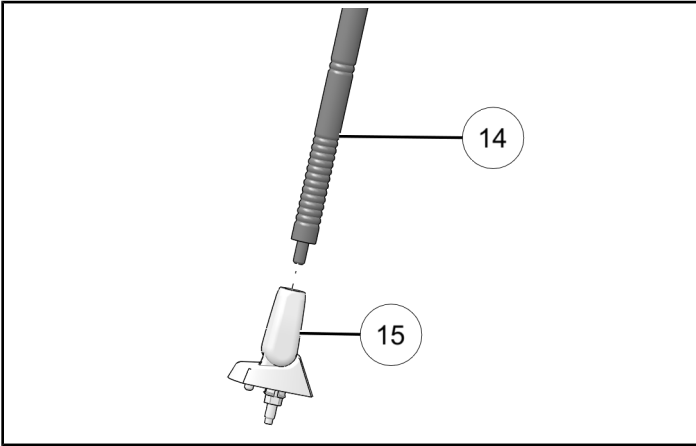

2. Seat antenna mount ⑮ in hood. Antenna mount will snap into place when fully seated.

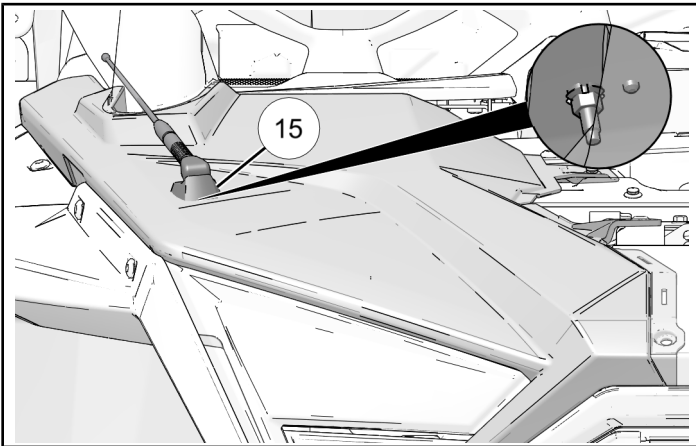

3. Pass antenna mount post ⑮ through ground strap ⑦, antenna harness ②, and secure with one nut ⑫. Place harness boot over nut after torquing.

TORQUE

Antenna Post Nut ⑫:
89 in-lbs (10 N·m)

NOTE

Vehicle body hidden for clarity.

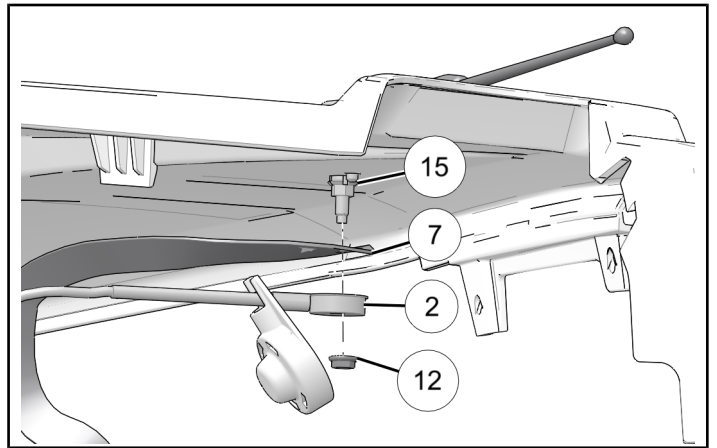

4. Replace hood to installed position (if disassembled) with harness sitting in front-right wheel well. Secure ground strap ⑦ to vehicle frame with one fastener ⑪.

TORQUE

Ground Strap Fastener ⑪:
89 in-lbs (10 N·m)

