



SATURN

Quick Start Guide



Your Success is Our Vision



Disclaimer and Limitation of Liability

The content of this manual is for information use only and is subject to change without notice. Star Systems International Ltd. assumes no responsibility or liability for any errors or inaccuracies that may appear in this publication. No part of this manual may be reproduced in any form or by any means, electronic, mechanical, recording, or otherwise, without the prior written permission of Star Systems International Ltd. Star Systems International Ltd. products are not designed, intended, authorized or warranted to be suitable for life support applications or any other life critical applications which could involve potential risk of death, personal injury, property damage, or environmental damage.

FCC Interference Statement (Part 15.105)

Note: This equipment has been tested and found to comply with the limits for a Class A digital device, pursuant to part 15 of the FCC Rules. These limits are designed to provide reasonable protection against harmful interference when the equipment is operated in a commercial environment. This equipment generates, uses, and can radiate radio frequency energy and, if not installed and used in accordance with the instruction manual, may cause harmful interference to radio communications. Operation of this equipment in a residential area is likely to cause harmful interference in which case the user will be required to correct the interference at his own expense.

Compliance Statement (FCC Part 15.19 and ISED RSS-GEN)

This device complies with part 15 of the FCC Rules and with Industry Canada's licence-exempt RSSs. Operation is subject to the following two conditions:

- (1) This device may not cause interference; and
- (2) This device must accept any interference, including interference that may cause undesired operation of the device.

Énoncé de Conformité

Le présent appareil est conforme aux CNR d'Industrie Canada applicables aux appareils radio exempts de licence. L'exploitation est autorisée aux deux conditions suivantes :

- 1) l'appareil ne doit pas produire de brouillage;
- 2) l'appareil doit accepter tout brouillage radioélectrique subi, même si le brouillage est susceptible d'en compromettre le fonctionnement.

Modification Warning (FCC Part 15.21)

Changes or modifications not expressly approved by Star Systems International Ltd. LLC could void the user's authority to operate the equipment.

Shielded Cables and Grounding (FCC Part 15.27)

Shielded cables and earth grounding the unit is recommended for this equipment to comply with FCC regulations.

FCC/ISED Radiation Exposure Statement

In order to comply with FCC/ISED RF Exposure requirements, the antennas used for this transmitter must be installed to provide a separation distance of at least 1.2 meters from all persons and must not be co-located or operating in conjunction with any other antenna or transmitter. This device complies with Health Canada's Safety Code. The installer of this device should ensure that RF radiation is not emitted more than the Health Canada's requirement. Information can be obtained at

http://www.hc-sc.gc.ca/ewh-semt/pubs/radiation/radio_guide-lignes_direct/index-eng.php

Afin de se conformer aux exigences d'exposition RF FCC / ISED, cet appareil doit être installé pour fournir au moins 1.2m de séparation du corps humain en tout temps.

Site License Disclaimer

Users of the Saturn RFID reader acknowledge that a site license is required for operation under FCC Part 90/ISED RSS-137 regulations. It is the user's responsibility to file for the site license and submit the appropriate fees and payments to the regulating authority.

Licence d'État-client Avertissement

Client (utilisateur final) reconnaît que le site d'une licence est requise pour chaque lecteur emplacement du système. Il incombe au client de déposer pour la licence d'exploitation et soumettre le paiement du dépôt approprié.

FCC Part 90

Pursuant to FCC Part 90.205, the Saturn RFID reader's radiated power is limited to +44.8dBm (30 Watts) ERP (Effective Radiated Power). The professional installer must enter the cable loss and antenna gain at the time of installation. Using this information, the Saturn RFID reader will automatically calculate and limit the maximum conducted output power that is allowed, based on the following equation:

Maximum conducted power (dBm) = 44.8 (ERP in dBm) – Antenna Gain (in dBd) + Cable Loss (in dB)

Note that Part 90 specifies the radiated power limit in terms of ERP and the Antenna Gain is specified in dBd, which is gain relative to an ideal half-wave dipole antenna.

Software Copyrights

This product uses the Toradex Apalis T30 Computer on Module (Linux variant). Please see The Toradex web pages for more information on licenses and source code.



Attention	1
Contents	3
Conventions.....	5
Product Use	6
1 Safety	7
1.1 Intended Use	7
1.2 Installation and Service Warnings.....	7
1.2.1 Power Supply Caution.....	7
1.2.2 Reader Caution	7
1.3 RF Safety.....	9
1.4 Electrostatic Discharge (ESD)	9
1.5 Power Cable Size.....	9
2 Getting Started	10
2.1 What is Saturn	10
2.2 Unpacking Saturn.....	10
2.3 What you will need.....	10
3 Installation.....	11
3.1 Mechanical	11
3.2 Reader Placement.....	13
3.3 Electrical Considerations.....	14
3.4 Electrical Connectors	14
3.5 Connections.....	15
3.5.1 LAN (Ethernet / PoE+).....	15
3.5.2 Auxiliary DC Power.....	16
3.5.3 GPIO / Serial.....	17
3.5.4 External Antenna	19
3.6 Grounding.....	19
4 Initial Reader Configuration.....	20
4.1 Ethernet.....	20
4.2 Serial Port	20
4.3 Digital I/O	20
4.4 Antennas	21
4.5 Regulatory Mode	21
4.6 Air Interface Protocols	21



5	Configuration	22
5.1	Command Line	22
5.2	Web Server	22
5.3	Logging In	22
5.3.1	Guest	22
5.3.2	Administrator	22
5.3.3	Installer	22
6	Troubleshooting.....	23
6.1	No LAN Connectivity	23
6.2	Transmitter Will Not Turn On	23
6.3	Antenna Detection Problems	23
6.4	Tag Detection Problems	23
7	Warranty	24
7.1	Exclusions	24
7.2	Return Materials Authorization (“RMA”) Process	24
7.3	Disclaimer of Warranties	24
7.4	Limitation of Liability	24

Conventions



The following conventions are used in this manual:

Bold courier font indicates code entered by the user

(values) within parentheses indicate parameters

(values) in italics indicate user defined variables.

<n> indicates a variable number used in a function that can apply to several different devices such as antennas or I/O ports.



WARNING: Indicates a hazardous situation which, if not avoided, could result in death or serious injury.



CAUTION: Indicates a hazardous situation which, if not avoided, could result in minor or moderate injury or property damage.



ATTENTION: This yellow symbol indicates that the device is susceptible to Electro Static Discharge and appropriate precautions must be taken to avoid equipment damage.

NOTICE: NOTICE advises the reader that a condition can be created by a particular action that can cause equipment damage or result in equipment operation that violates regulatory requirements.



Factors beyond Star Systems International Ltd.'s control and within the installer and user's knowledge and control can affect the performance of this product. Given the factors that can affect the performance of this product, the user is solely responsible for evaluating this product and determining if it is fit for a particular application.

Warranty, Limited Remedy, and Disclaimer: Unless a different warranty is specifically stated on the applicable product packaging, product literature, terms of sale or software license agreement, Star Systems International Ltd. warrants that (i) the product will be free from substantial defects in material and workmanship under normal use and service for one (1) year from the original date of purchase, and (ii) for software products, for ninety (90) days from the original date of purchase, the software will materially perform the functions described in the accompanying documentation. Star Systems International Ltd. makes no other warranties or conditions, express or implied, including, but not limited to, any implied warranty or condition of merchantability or fitness for a particular purpose or any implied warranty or condition arising out of a course of dealing, custom or usage of trade. If the Star Systems International Ltd. product does not conform to this warranty, then the sole and exclusive remedy is, at Star Systems International Ltd.'s option, repair or replacement of the Star Systems International Ltd. product.

Limitation of Liability: Except where prohibited by law, Star Systems International Ltd. will not be liable for any loss or damage arising from the Star Systems International Ltd. product, whether direct, indirect, special, incidental or consequential, regardless of the legal theory asserted, including warranty, contract, negligence or strict liability.



1.1 Intended Use

The Saturn RFID Reader is intended for use within automatic vehicle identification (AVI) applications, such as Intelligent Transportation Systems (ITS), Traffic Management Systems (TMS), Electronic Vehicle Registration (EVR), parking management and billing, and access control. It is expected that all users be fully trained in the safe operation of this device.

Use in any other application has not been evaluated by Star Systems International Ltd. and may lead to an unsafe condition.

1.2 Installation and Service Warnings

 **WARNING:** To reduce the risks associated with hazardous voltage, fire and impact:

- Installation and service of Saturn RFID Reader systems is to be performed by qualified installation personnel.
- Installation and service activities must follow all applicable building and electrical codes.
- Inspect all system components at least every 6 months.

1.2.1 Power Supply Caution

 **WARNING:** To reduce the risks associated with hazardous voltage and fire:

- Always disconnect the system power before any installation, maintenance, service or modification work.
- Ensure that it cannot be re-connected inadvertently.
- Connection to main power supply in compliance with VDE01000 and EN50178.
- For stranded wires: all strands must be secured in the terminal blocks.
- Power supply and cables must be properly fused.
- If necessary, a manually controlled disconnecting element must be used to disengage from supply mains.
- All output lines must be rated for the power supply output current and must be connected with the correct polarity.
- Do not block vents on power supply.
- Do not introduce any object into the power supply.
- Keep power supply away from fire and water.

1.2.2 Reader Caution

 **WARNING:** To reduce the risks associated with hazardous voltage and fire:

- Always disconnect AC power from the power supply unit when connecting or disconnecting components of the system.
- System modification and service by Star Systems International Ltd. authorized personnel only.

 **WARNING:** To reduce the risks associated with hazardous voltage and nonionizing radiation exposure:

- Do not modify or attempt to service the Reader System. Return to Star Systems International Ltd. authorized service centers for repair or service. There are no user serviceable parts.

 **WARNING:** To reduce the risks associated with non-ionizing radiation exposure and property damage:

- Always turn off the RF from the antenna before cleaning, inspecting, service or repair.

 **WARNING:** To reduce the risks associated with electromagnetic interference:

- Use only the antennas described in this manual or equivalent substitutes.

 **WARNING:** To reduce the risks associated with hazardous temperature and fire related to the power supply:

- Do not cover ventilation holes in power supply.
- Leave sufficient space around the power supply for cooling.
- Do not mount directly above a heat source.
- Disconnect unit from power before installation, maintenance, service, or modification.
- Do not use in wet or damp locations.
- Do not use near flames.
- Always disconnect AC power from the power supply unit when connecting or disconnecting components of the system.

 **WARNING:** To reduce the risks associated with hazardous voltage:

- Replace damaged components only with Star Systems International Ltd. designated replacement parts.
- Use only the power supply specified by Star Systems International Ltd.

 **WARNING:** To reduce the risks associated with fire and explosion:

- Do not install in a hazardous location.

 **WARNING:** To reduce the risks associated with impact:

- Any mounting surface must be able to support a minimum static load of equal to the maximum weight of the reader plus any additional live load due to environmental conditions.

 **WARNING:** To reduce the risks associated with impact, muscle strain and abrasions:

- Use appropriate PPE and follow safe workplace practices during installation.

 **CAUTION:** To reduce the risks associated with hot surfaces and reader performance:

- Do not paint the reader, antenna(s), and power supply any color.

 **CAUTION:** To reduce the risk associated with rough edges:

- Wear appropriate gloves when handling the reader and antenna mounting hardware.

 **CAUTION:** To reduce the risks associated with environmental contamination:

- Dispose of all system components in accordance with applicable local and government regulations, including removal of button battery, prior to disposal.

NOTICE: Do not use solvents or harsh cleaners on reader or antennas.

1.3 RF Safety

NOTICE: The Saturn RFID Reader is equipped with one (1) external RF port.

To prevent reader damage, an unused external RF port must be properly terminated with a 50-ohm load or a functional UHF antenna before powering up if the reader has been configured to use this port. Never power up the reader unless the appropriate load or antenna is connected. Always power down the reader before removing an antenna or load from an RF port.

The maximum external antenna cable length is 10 meters.

1.4 Electrostatic Discharge (ESD)



ATTENTION Saturn RFID Reader antenna ports may be susceptible to damage from static discharge or other high voltage. Use proper Electrostatic Discharge (ESD) precautions to avoid static discharge when handling or making connections to the Saturn RFID Reader antenna or communication ports. Equipment failure can result if the antenna or communication ports are subjected to ESD.

1.5 Power Cable Size



WARNING: The Star Systems International Ltd. supplied power/data cable is only to be used with the Star Systems International Ltd. 24 VDC power supply. Use of these cables with power supplies providing lesser voltages may result in cable and/or reader damage.

2 Getting Started



2.1 What is Saturn

The Saturn RFID reader is a high performance Multi-Protocol UHF reader specifically designed for high speed vehicle identification applications. The Saturn has an integrated antenna and optionally supports one external antenna. The Saturn communicates to the host system via Ethernet over a LAN connection or via RS232 over a serial connection. Power can be provided over the LAN connection using power-over-ethernet (“PoE” via 802.3at standard) or using a dedicated DC input. The Saturn has two fully isolated solid-state relay outputs and two fully isolated digital inputs for general purpose use.

2.2 Unpacking Saturn

After unpacking the Saturn, please save the packing material and box. There is one RFID reader included in each box along with the regional documentation package. Included in the documentation package is this Quick Start Guide, appropriate compliance documentation, and a service card with the installer login credentials.

2.3 What you will need

The Saturn is shipped without external cables. Please read the following sections to help determine what cables are needed. The cables are industry standards and can be ordered from Star Systems International Ltd. or through third parties.

The Saturn is shipped without a mounting bracket. Please read the following sections to help determine what mounting bracket(s) are needed. The brackets can be ordered from Star Systems International Ltd. or through third parties.

The Saturn is shipped without an external antenna. Please read the following sections to help determine if and what external antenna is needed. The external antenna can be ordered from Star Systems International Ltd. or through third parties.

3 Installation

Before proceeding with the installation of the reader, it is recommended to have a proper site plan. A site plan will dictate which cables are needed for your application.

For licensed frequency installations the frequencies to be used are also needed.

3.1 Mechanical

The Saturn RFID Reader is housed in the MTI MT-900042 enclosure shown in FIGURE 1 and FIGURE 2. The integrated antenna attached to the housing in typically MT-263005/S/E as shown in FIGURE 4.

A standard mounting bracket is available with part number MT-120018.

- ⚠ CAUTION: Any mounting surface must be able to support a minimum static load of 15.0 pounds (7 kg) plus any additional live load due to environmental conditions.

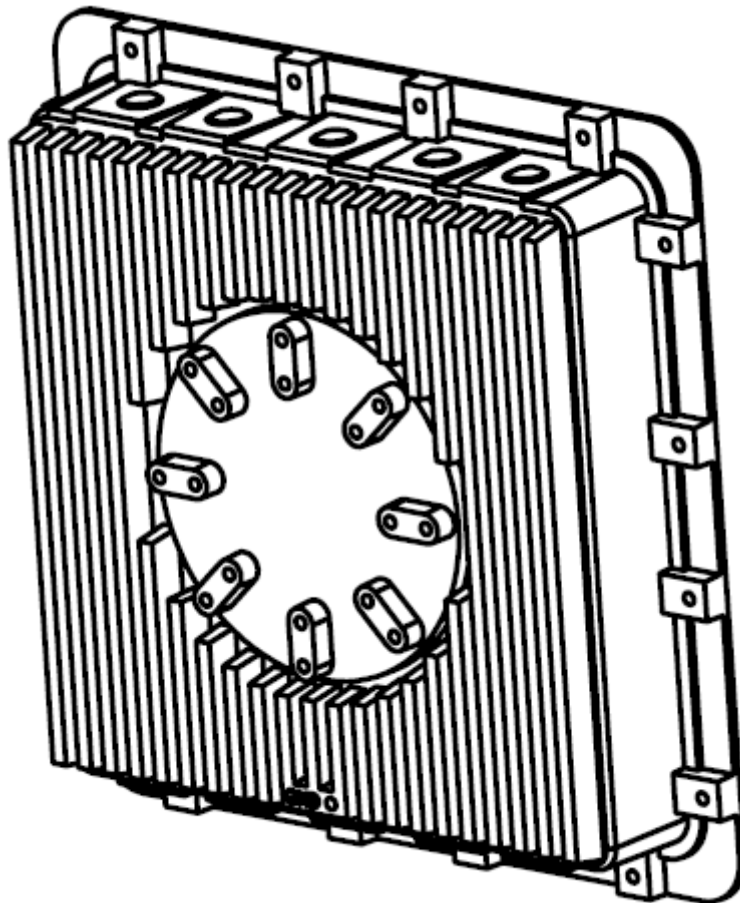

FIGURE 1: Illustration of enclosure from MT-900042 Drawing

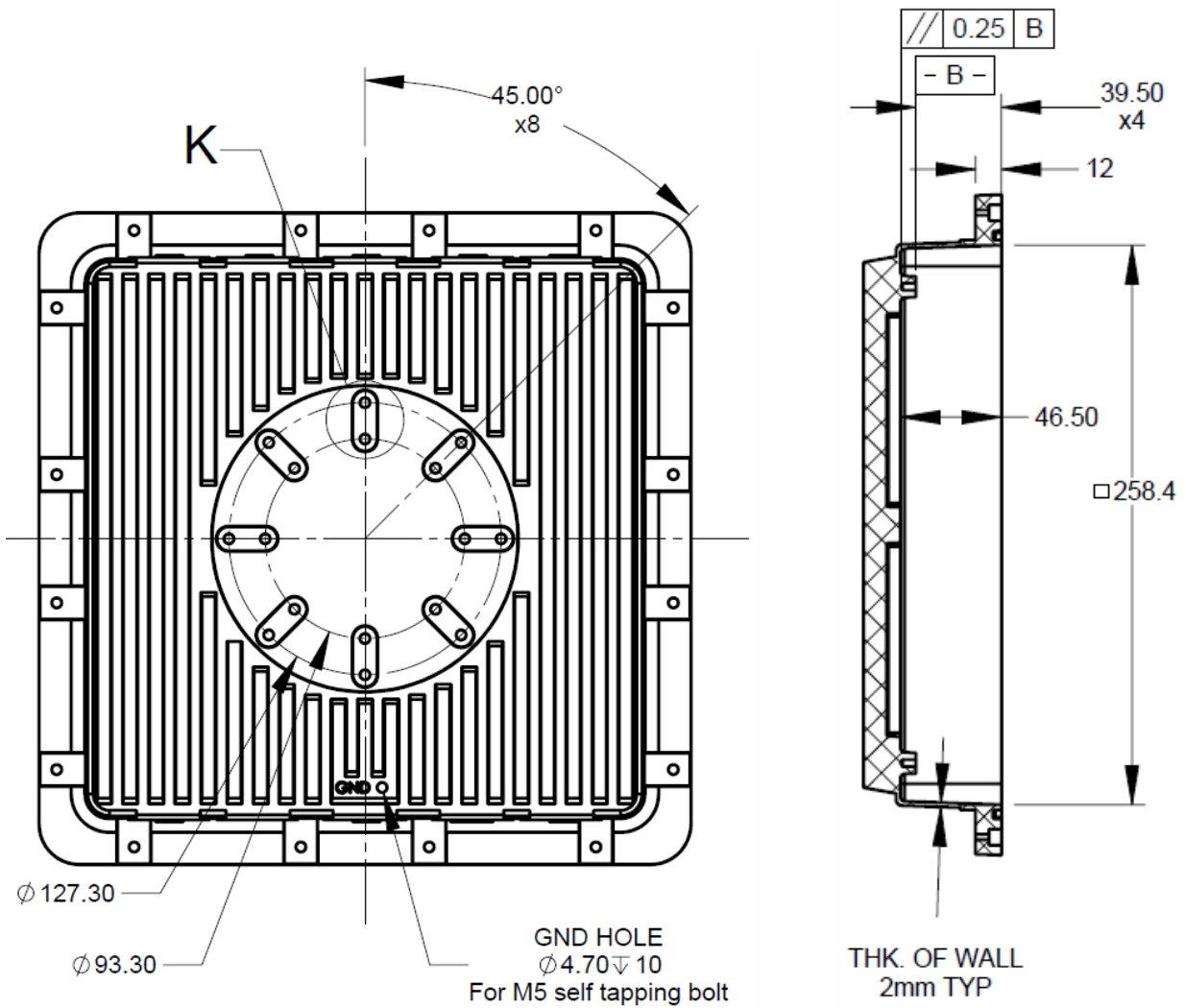

FIGURE 2: Dimensions for mounting hardware of MT-900042 enclosure

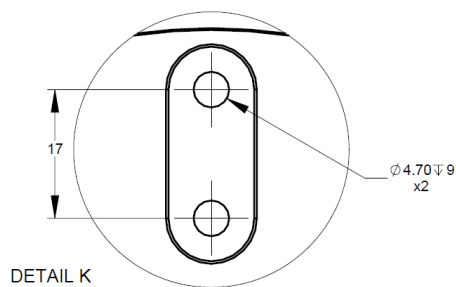

FIGURE 3: Dimensions for mounting hardware of MT-900042 enclosure, detail "K"

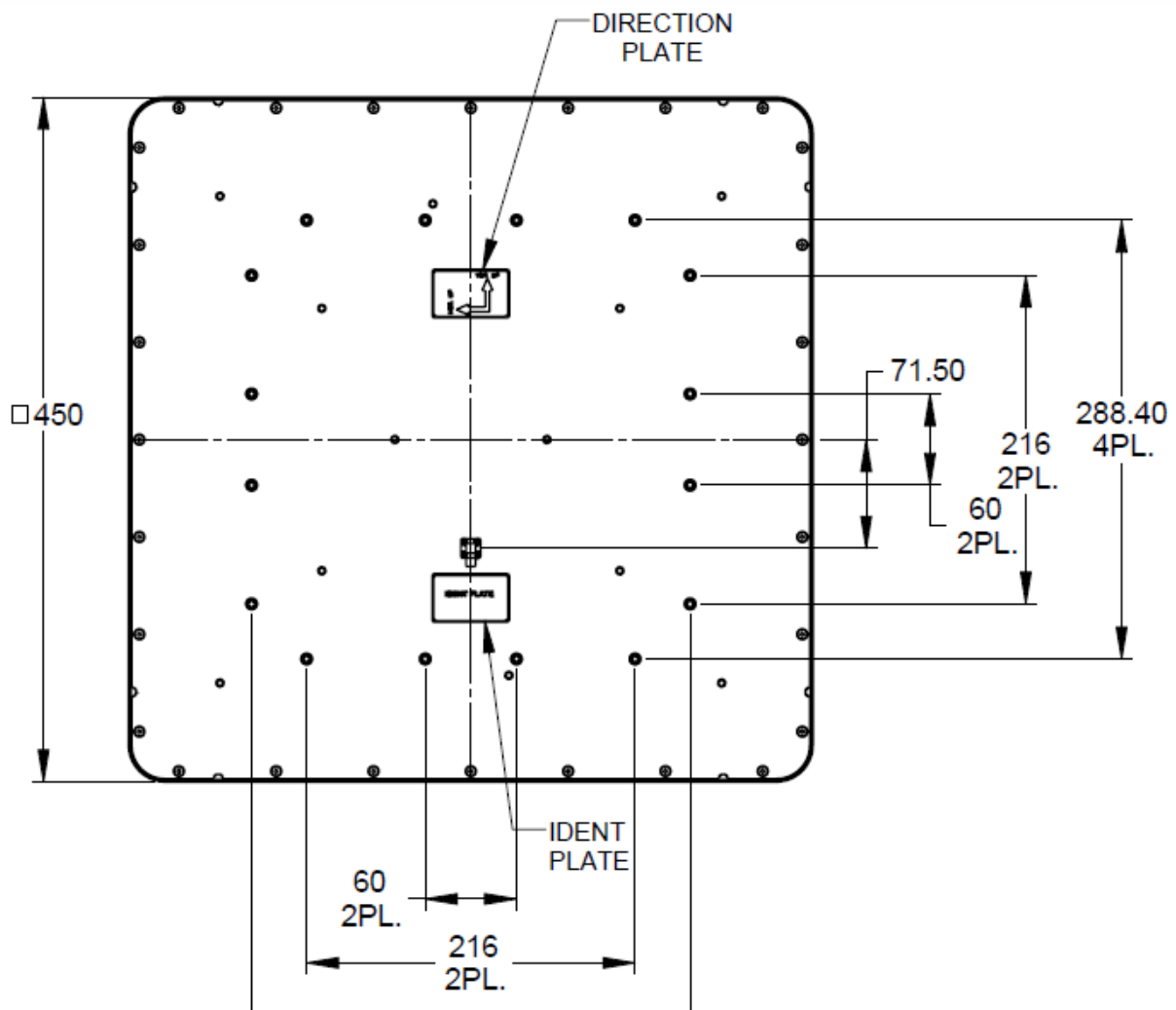

FIGURE 4: Dimensions of integrated antenna MT-263005/S/E

To mount the Saturn RFID Reader, refer to the MT-900042 and MT-120018 mounting instructions. In summary, perform the following:

1. Prepare the mounting area as described in the MT-900042 and MT-120018 mounting instructions.
2. Mount the reader.
3. Attach the interface cables (see next sections).
4. Optionally connect the external antenna cable.
5. Adjust the angle of the antennas and tighten the hardware.

3.2 Reader Placement

Things to consider when developing a proper site plan includes mounting, site layout, reader/tag alignment, traffic flow lanes, local electrical codes and LAN requirements. It is recommended to contact your local STAR SYSTEMS INTERNATIONAL LTD. sales representative to aid in the proper planning of your application.

3.3 Electrical Considerations

Cable lengths are an important factor when developing a site plan and there are losses to consider. As a rule, it is always good practice to keep the cable lengths as short as possible. The voltage measured at the reader needs a minimum of 12VDC to function properly.

3.4 Electrical Connectors

NOTICE: The Saturn RFID Reader is designed to meet the regulatory requirements in those jurisdictions in which it is offered. Changes or modifications not expressly approved by Star Systems International Ltd. for compliance could void the user's authority to operate the equipment.



ATTENTION: The Saturn RFID Reader antenna ports may be susceptible to damage from static discharge or other high voltage. Use proper Electrostatic Discharge (ESD) precautions to avoid static discharge when handling or making connections to the Saturn RFID Reader antenna or communication ports. Equipment failure can result if the antenna or communication ports are subjected to ESD.

FIGURE 5 below illustrates the complete set of interconnections for the reader. Note that for a minimal installation only the LAN port need be connected to a PoE+ capable switch.

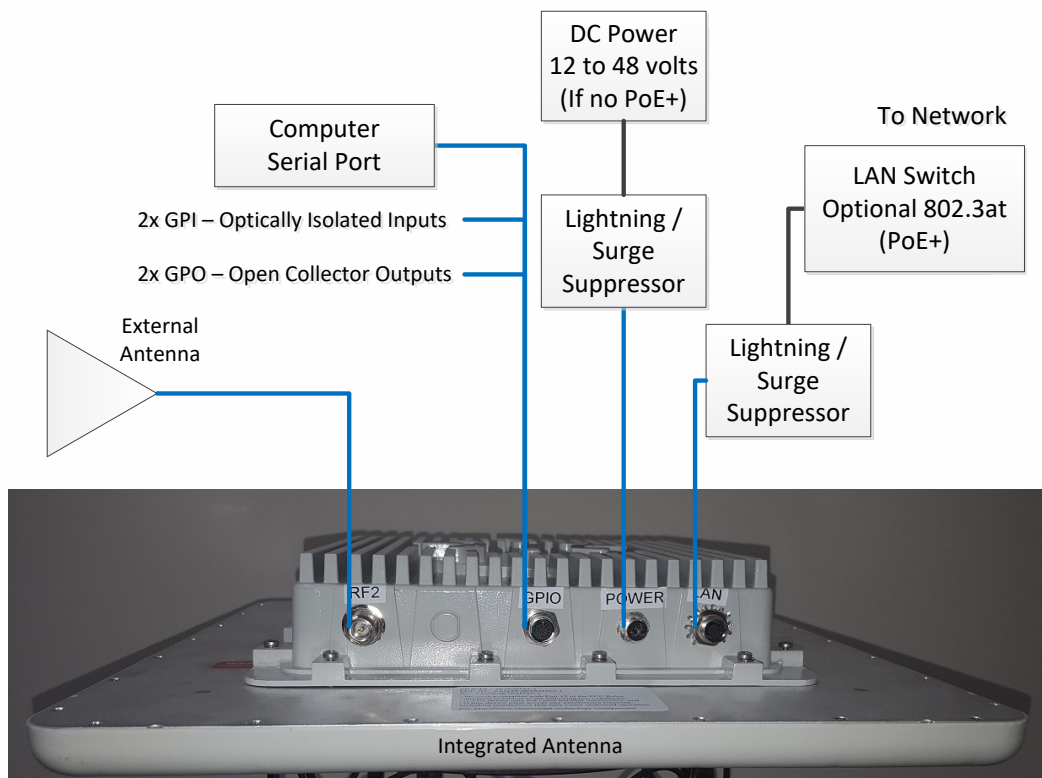

FIGURE 5: Saturn RFID Reader Connection Diagram

3.5 Connections

The connector faceplate diagram is shown in FIGURE 5, which also shows a schematic of the possible interconnections. The specifications for the individual connections are given in the following subsections.

3.5.1 LAN (Ethernet / PoE+)

The LAN connector is a 4-pair, 26 AWG stranded (7-wire), M12 flush-type socket. The LAN connector can serve for communications and/or IEEE 802.3at power over ethernet (PoE+). It is possible to use this connector for the one and only connection to the Saturn RFID reader, supplying both the communications interface and the required power supply.

External cables are available from a wide variety of vendors in many lengths with unterminated, M12, RJ45, or other end terminations. An example from Phoenix Contact in 10-meter length is part number 1440630.

Ethernet

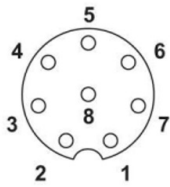

M12 Socket
8 Position
A-Coded

Pin	Mode A	Mode B	Description
1	Rx+, DC+	Rx+	LAN Rx+, DC+ for Mode A POE Spec
2	Rx-, DC+	Rx-	LAN Rx-, DC+ for Mode A POE Spec
3	Tx+, DC-	Tx+	LAN Tx+, DC- for Mode A POE Spec
4	Unused	DC+	DC+ for Mode B POE Spec
5	Unused	DC+	DC+ for Mode B POE Spec
6	Tx-, DC-	Tx-	LAN Tx-, DC- for Mode A POE Spec
7	Unused	DC-	DC- for Mode B POE Spec
8	Unused	DC-	DC- for Mode B POE Spec

FIGURE 6: LAN Connector

3.5.2 Auxiliary DC Power

If PoE is not used, then DC power must be supplied through the auxiliary DC power connector. This connector is a 4 position M16 flush-type plug, A-coded, as shown in FIGURE 7.

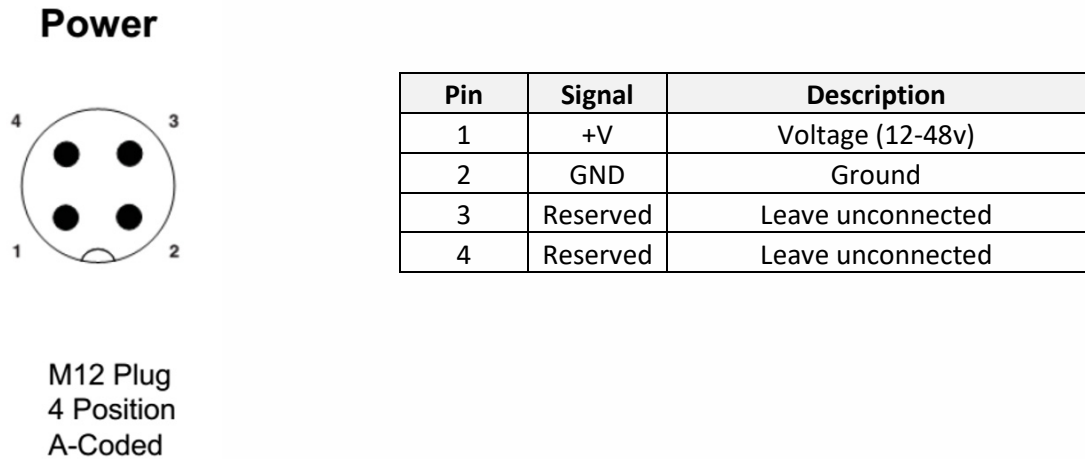

FIGURE 7: Aux DC Power Pin Out

- ⚠ WARNING:** The Saturn RFID Reader may draw up to 19 watts at the DC power connector input. The input voltage range is from 12 volts to 48 volts. The current draw will depend on the supplied voltage **at the connector input**. Therefore, it is the professional installer's responsibility to account for the voltage drop across the DC power cable and use a safe wire gauge for the voltage and current combination being used.

3.5.3 GPIO / Serial

The digital inputs, digital outputs, and RS232 serial connection is available through the GPIO / Serial connector. This connector is a 12 position M12 flush-type socket, A-coded, with pinout as shown in FIGURE 8.

GPIO/RS232

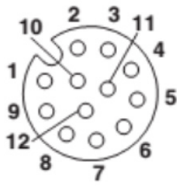

M12 Socket
12 Position
A-Coded

FIGURE 8: GPIO/Serial Pin Out

Pin	Signal	Description
1	GND	Ground
2	GPO_1	Open Collector General Purpose Output #1
3	GPO_2	Open Collector General Purpose Output #2
4	GND	Ground
5	GPI_1	Optically Isolated Input #1
6	GPI_2	Optically Isolated Input #2
7	GND	Ground
8	Tx	RS-232 Transmit
9	Reserved	Do not connect
10	Rx	RS-232 Receive
11	GND	Ground
12	Reserved	Do not connect

3.5.3.1 General Purpose Inputs

General purpose inputs are fully galvanic isolated, optically coupled inputs with an input voltage range of 5 volts to 24 volts. Please refer to FIGURE 9 for a simplified circuit schematic. When the external logic controller holds the GPI input high, current flows through the LED, which in turn enables the NPN transistor, which results in the internal GPI signal to the Saturn processor being pulled low. Under no circumstances should the LED current exceed 20 milliamps.

The two inputs available on the GPIO/Serial connector can be used to signal events or status to the Saturn processor, normally used to trigger RFID read cycles or to stop RFID read cycles. Please refer to the User's Manual for more information regarding the I/O capabilities.

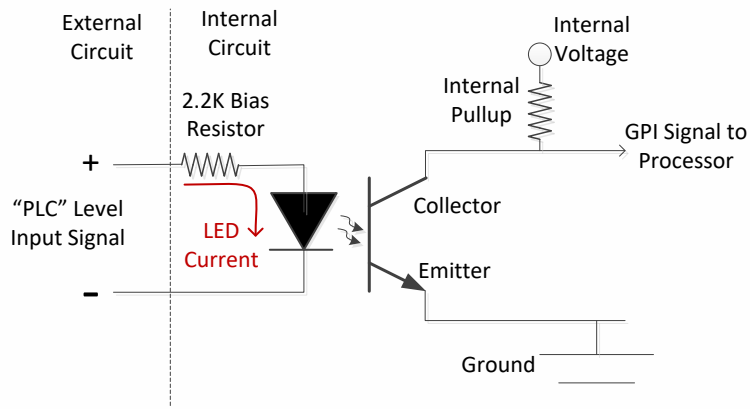

FIGURE 9: General Purpose Input Simplified Schematic

3.5.3.2 General Purpose Outputs

General purpose outputs are fully galvanic isolated, solid state relays capable of carrying 1 amp with a maximum voltage of 24 volts across the terminals when inactive. The two open collector outputs available on the GPIO/Serial connector can be used like relays. An external supply is used tied across a load. The load could be a lamp, a relay coil, or pullup resistor. The software enables and disables the relay.

Please refer to the User's Manual for more information regarding the I/O capabilities.

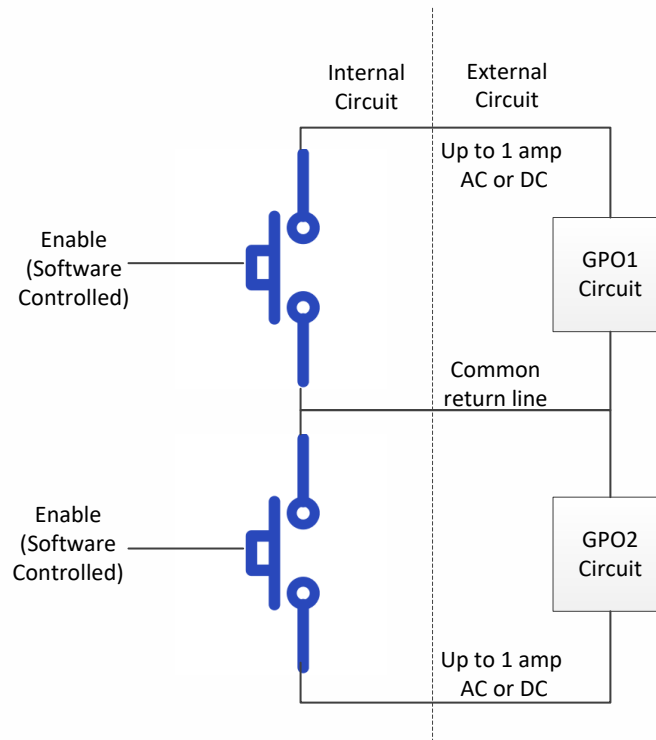

FIGURE 10: General Purpose Output

3.5.3.3 RS232 Serial

The default serial connection configuration is as follows:

- 115.2 Kbps
- 8 bits
- 1 start bit
- 1 stop bit
- No parity

These settings are configurable once a connection is made to the reader. Please refer to the User's Manual for more information regarding the serial port.



3.5.4 External Antenna

The external antenna connector is a 50-ohm type-N jack. In FCC type environments the MT-263005-N is the approved external antenna. The Saturn supports up to 2 antenna connections (1 integrated, 1 external) simultaneously with various protocols. Please refer to the User's Manual for specifics.

3.6 Grounding

Connect the Saturn enclosure to earth ground using a ground cable and stake. FIGURE 2 shows the location of the "GND HOLE" for system grounding. Minimum wire size for lightning protection is 0 AWG. Follow the National Electric Code for lightning protection for the locale where you are installing the Saturn Reader.

4 Initial Reader Configuration



4.1 Ethernet

The reader defaults to using DHCP and will take on the IP address provided by the DHCP server. If there is no DHCP server it will obtain an IP address by negotiating with other network devices on the non-DHCP network. Typically, it will get an IP address in the 169.254.*.* space.

The reader can also be configured to obtain a static IP address. Please see section the User's Manual for additional details.

To "discover" the reader's IP address, you can use a Bonjour client like "avahi" or you can use the reader's Java GUI software. The available ports on the reader are described in the table below.

Interface	Description
TCP Port 50007	CLI Command Port
TCP Port 50008	CLI Event Port
TCP Port 5084	LLRP Port
TCP Port 22	SSH Port / Linux Bash Shell
TCP Port 80	Web Interface
Syslog	Outputs to a remote UDP Port 514
TCP Port 3334	Firmware Update Port <ul style="list-style-type: none">Automatically used by Web and GUI Updates
UDP Port 3333	Discovery port (Multicast IP addresses 239.192.7.1 and 239.192.7.2)
NTP	Network Time Protocol Client

4.2 Serial Port

The serial port can be used to access a Linux Bash Shell and can be used to startup user applications (See User's Manual for additional details). The default Linux login is username "user" and password "user".

4.3 Digital I/O

The two digital inputs and two digital outputs can be used to either trigger the reader to enter or leave active mode or to perform other user operations. Please see the User's Manual for additional details.

To facilitate and confirm initial wiring, the digital I/O can be monitored and the output can be changed via the Reader Host Software Java GUI at the top frame of the GUI on the right-hand side:

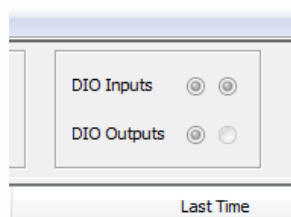

A dark shaded circle means the status of the Input/Output is "high" and "low" otherwise. To change the state of the Output, please double click on the circle corresponding to the output that needs to be changed.

4.4 Antennas

The antennas can be configured from the antennas CLI namespace. This allows the user to configure power type settings. As well, the antenna order of operations can be configured by the “antennas.mux_sequence” CLI command described in that same section.

The antennas can be configured with the Reader Host Software Java GUI via the “Configure” and then the “Antennas” menu.

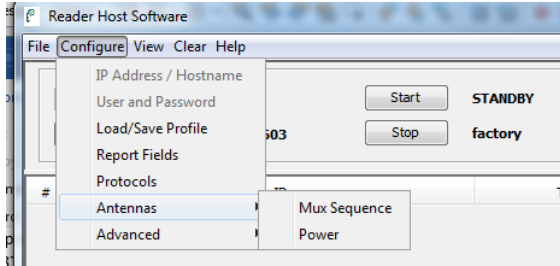

4.5 Regulatory Mode

The regulatory mode of the region can be configured with the CLI commands “setup.region” and “setup.valid_regions”. Please see the User’s Manual for additional information on how to use those commands. You must be logged in as an “installer” to modify this parameter. The “admin” and “guest” user logins will not be sufficient.

4.6 Air Interface Protocols

The Saturn reader supports up to four protocols operating simultaneously on the reader. The available protocols on the reader can be obtained via the CLI command “setup.valid_protocols” and the configured protocols can be setup via the CLI command “setup.protocols”. Please see the User’s Manual for additional information.

The protocols can also be configured via the Reader Host Software Java GUI via the “Configure” and then “Protocols” menu.

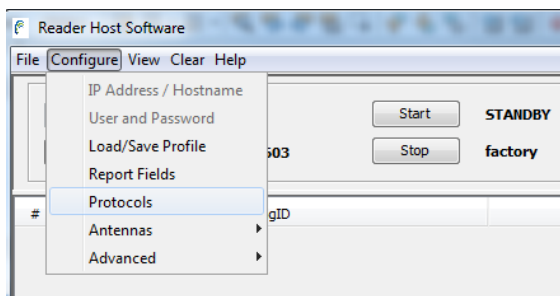

The valid protocols for the Saturn reader are:

- ISOC
- PS111
- ISOB
- ISO10374

5 Configuration

The Saturn reader can be configured using a command line interface or a web server. A command line connection is established by opening a TCP/IP socket connection to port 50007 on the reader. To enable specific protocols and antenna ports please refer to the User's Manual on specifics for your application.

5.1 Command Line

The Saturn reader supports the "C2" command line interface. This interface has various levels of permission and allows the users to configure, test and operate the reader. Please refer to the User's Manual for more information.

5.2 Web Server

The Saturn also supports an embedded web server which can be used in addition to the C2 command line interface. This web server can also be utilized for configuration, test and proper operation of the reader. Please refer to the User's Manual for more information.

5.3 Logging In

5.3.1 Guest

The default initial login level upon opening a new command line connection is "guest" with default password "guest". A guest user is allowed to log in to a higher login level and view (but not change) limited configuration settings.

5.3.2 Administrator

A guest user can upgrade their login level to "admin" with the command "`reader.login(admin,admin_password)`", where `admin_password` is the password for the administrator account. The default password is "admin". Please refer to the User's Manual for information on changing or resetting the password. An administrator account can change reader configuration and fully operate the reader.

5.3.3 Installer

The Installer password can be found on the service card included with the Saturn reader. The Installer is responsible for setting the correct regulatory mode, and in a licensed frequency installation, the correct frequency. Please refer to the User's Manual for more information.



6.1 No LAN Connectivity

1. Verify the auxiliary DC input is from 12 to 50 volts **at the Saturn input**.
 - a. It is important to account for voltage drops in the cable.
 - b. The Saturn reader will draw about 12 watts in its power up sequence. The Saturn reader will draw about 18 watts at full power operation at 25 degrees C.
 - i. The current draw will depend on the voltage at the reader input terminals
 - ii. The voltage drop across the supply cable will depend on the wire gauge and the length of cable
2. If using a PoE switch, try using an auxiliary DC input
3. If using a PoE switch, ensure the switch is 802.3at compliant (“PoE+)
4. Ensure your Ethernet connection cable has all four pairs of cable – required for PoE+
5. Connect a serial cable – the Saturn processor reports a rich set of status and events during startup, including events related to LAN network connectivity
6. Use the serial cable to reset the LAN connection to DHCP (default)
 - a. Ensure there is a DHCP server on the network
7. Alternatively, set the Saturn reader to a static IP address accessible on the network

6.2 Transmitter Will Not Turn On

1. Check the “Return Loss” to each antenna(s) configured
2. Check the valid protocols
3. Valid protocols not configured

6.3 Antenna Detection Problems

Disconnect the antenna cable and attach a known good termination, such as Minicircuits part number **KARN-50CN+** or similar.

- If this does not detect, contact Star Systems International Ltd.
- If the known good termination does connect, examine the cable and antenna for connection problems.

6.4 Tag Detection Problems

Be sure to use a known good tag for tests. In addition, perform the following:

1. Confirm the antennas detected list is as expected
2. Check the transmitter power

7 Warranty



All Hardware Products sold by Star Systems International Limited (SSI) are warranted against defects in material and workmanship under normal use and service for one (1) year from the original date of purchase (the “Warranty”). Any Extended Warranties must be documented on the original invoice as a separate line item. For defects covered by this Warranty, SSI will repair the defect or replace the product, at its sole option and return the product to you.

7.1 Exclusions

If the defect was caused by any of the following, the Warranty shall not apply and an estimate for repair or replacement will be submitted for your approval prior to work being performed: abuse, mishandling, acts of God, vandalism, accident, electrostatic discharge damage, failure to follow installation or operating instructions, failure to provide a suitable environment, unauthorized modification of the product modification of the printed circuit board by parties other than SSI, and damage that is caused during shipping for warranty service and any product that is returned with the security seal broken.

7.2 Return Materials Authorization (“RMA”) Process

For Warranty service, the Customer must comply with Star Systems International Return Materials Authorization (“RMA”) policy, which is published on the Star Systems International website at www.star-int.net, and may be updated from time to time. Prior to shipping a product to Star Systems International for warranty inspection, replacement or repair, an RMA number must be obtained from Star Systems International’s RMA department at +852 3691 9925 or by email at support@star-int.net. RMA forms can be downloaded from the Star Systems International website or the Customer can receive the form by email by contacting the RMA department. One RMA form must be used for each RMA submission and the product should be shipped to the address below. For products covered by this Warranty, the Customers are responsible for payment of shipping costs to the Star Systems International repair center and Star Systems International will be responsible for the cost of returning the item. The standard return shipment is “Speed Post”. Any other desired “expedited” or overnight shipping costs for warranty repairs will be the customer’s responsibility.

7.3 Disclaimer of Warranties

Other than set forth above, SSI hereby disclaims all warranties, expressed or implied, including without limitation, the warranties of equipment warranty (rev 2-2017) merchantability, fitness for a particular purpose and noninfringement.

7.4 Limitation of Liability

In no event will SSI be liable for any consequential, indirect, exemplary, special, or punitive damages, whether arising out of contract, tort, negligence, strict liability or otherwise. In no event will Star Systems International’s total cumulative, aggregate liability, whether arising out of contract, tort, negligence, strict liability, or otherwise, exceed the price actually paid by the customer for the product from which the claim arises.

This warranty gives the Customer specific legal rights, and the Customer may also have other rights that may vary from local jurisdiction. If the Customer has questions concerning the product or warranty, contact the dealer from which it was purchased. The Customer may also contact Star Systems International at the following address and ask for warranty assistance.



About Us

STAR Systems International is a market leader providing solutions including RFID transponders, readers and professional consulting services for Auto ID & Vehicle Identification Applications. STAR Systems leverages technical implementation expertise, training and support to ensure customer success. "Your Success Is Our Vision".

Our focus is providing best-in-class technologies for Smart City Initiatives including; Electronic Tolling (ETC), Electronic Vehicle Registration (EVR), Fleet Management, Parking and Secure Access Control applications. Our mission is to enable our partners and users to experience high-performance and reliable integrated solutions which are key elements of any modern Smart City initiative.

For more information on STAR Systems visit www.star-int.net.

Technical Support

Visit the SSI website at www.star-int.net **Download** page to download our documents.

Visit the Star Systems University at www.star-int.net and click **Tech Support > Star Systems University** to review technical information or to request technical support for your RFID product.



Saturn Quick Start Guide Version 1.0.2

Copyright © 2018 SSI reserves the right to change specifications without prior notice

Hong Kong - Headquarters

Star Systems International Ltd
Unit 04, 12/F Vanta Industrial
Centre, 21-33 Tai Lin Pai Road,
Kwai Chung, Hong Kong

sales@star-int.net
+852 3691 9925

India

1118, Naurag House, 21 KG
Marg, Connaught Place,
New Delhi 110 001,
India

insales@star-int.net
+91 11437 55220

Latin America

190 E Stacy Rd. Suite 306-321
Allen, TX 75002

latinsales@star-int.net
+57 3013255118

North America

ussales@star-int.net
+1 888 457 7755 (US Toll Free)

EMEA

emeasales@star-int.net

Taiwan

twsales@star-int.net