

TEST REPORT

Report No.: SHATBL2401024W01

Applicant : Star Systems International Limited
Product Name : RFID Reader
Brand Name : SSI
Model Name : HRD30000
FCC ID : 2AA7KCELESTIA30000
Test Standard : 47 CFR Part 15.247
Date of Test : Dec. 13,2023~Jan. 09,2024

Report Prepared by : Chris Xu
(Chris Xu)

Report Approved by : Ghost Li.
(Ghost Li)

Authorized Signatory : Terry Yang
(Terry Yang)



TABLE OF CONTENTS

REVISION HISTORY	3
DECLARATION OF REPORT	4
SUMMARY OF TEST RESULT	5
1. GENERAL DESCRIPTION	6
1.1. Applicant	6
1.2. Manufacturer	6
1.3. General Information of EUT	7
1.4. Equipment Specification	8
1.5. Modification of EUT	8
1.6. Laboratory Information	8
1.7. Applicable Standards	8
2. TEST CONFIGURATION OF EUT	9
2.1. Carrier Frequency Channel	9
2.2. Test Modes	10
2.3. Block Diagram of Test System	11
2.4. Description of Support Units	11
2.5. Test Software and Power Level	11
2.6. EUT Operating Conditions	11
2.7. Equipment List	12
2.8. Measurement Uncertainty	14
3. TEST RESULT	15
3.1. Maximum Output Power	15
3.2. Number of Hopping Frequencies	18
3.3. Average Time Occupancy	19
3.4. 20dB Bandwidth	20
3.5. Carrier Frequency Separation	21
3.6. Conducted Band Edge	22
3.7. Conducted Spurious Emission	23
3.8. Radiated Spurious Emission and Restricted Band	24
3.9. AC Power-Line Conducted Emission	28
3.10. Antenna Requirement	30
4. TEST SETUP PHOTOGRAPHS	31
5. PHOTOGRAPHS OF EUT	31

REVISION HISTORY

Rev.	Issue Date	Revisions	Revised by
00	2024.1.9	Initial Release	N/A

DECLARATION OF REPORT

1. The device has been tested by ATBL, and the test results show that the equipment under test (EUT) is in compliance with the requirements of 47 CFR 15.247. And it is applicable only to the tested sample identified in the report.

2. This report shall not be reproduced except in full, without the written approval of ATBL, this document only be altered or revised by ATBL, personal only, and shall be noted in the revision of the document.

3. The general information of EUT in this report is provided by the customer or manufacture, ATBL is only responsible for the test data but not for the information provided by the customer or manufacture.

4. The results in this report is only apply to the sample as tested under conditions. The customer or manufacturer is responsible for ensuring that the additional production units of this model have the same electrical and mechanical components.

5. In this report, '' indicates that EUT does not support content after '' , and '' indicates that it supports content after ''

SUMMARY OF TEST RESULT

Report Section	Standard Section	Test Item	Judgment	Remark
3.1	47 CFR 15.247(b)(2)	Maximum Peak Conducted Output Power	PASS	--
3.2	47 CFR 15.247(a)(1)	Number of Hopping Frequencies	PASS	--
3.3	47 CFR 15.247(a)(1)(i)	Dwell Time	PASS	--
3.4	47 CFR 15.247(a)(1)	20dB Bandwidth	Report only	--
3.5	47 CFR 15.247(a)(1)	Carrier Frequency Separation	PASS	--
3.6	47 CFR 15.247(d)	Conducted Band Edge	PASS	--
3.7	47 CFR 15.247(d)	Conducted Spurious Emission	PASS	--
3.8	47 CFR 15.247(d)/15.209(a)/15.205(a)	Radiated Spurious Emission and Restricted Band	PASS	--
3.9	47 CFR 15.207(a)	AC Power-Line Conducted Emission	PASS	--
3.10	47 CFR 15.203	Antenna Requirements	PASS	--

1. GENERAL DESCRIPTION

1.1. Applicant

Name : Star Systems International Limited
Address : Unit 7, 8/F, Vanta Industrial Centre, 21-33 Tai Lin Pai Road
Kwai Chung, N.T., Hong Kong

1.2. Manufacturer

Name : Star Systems International Limited
Address : Unit 7, 8/F, Vanta Industrial Centre, 21-33 Tai Lin Pai Road
Kwai Chung, N.T., Hong Kong

Factory

Name : IDRO Co., Ltd
Address : #407-2, 17 Daehak 4-ro, Yeongtong-gu, Suwon-si, Gyeonggi-do, South Korea 16226

1.3. General Information of EUT

General Information	
Equipment Name	RFID Reader
Brand Name	SSI
Model Name	HRD30000
Series Model	HRD3000X(X=0-9, A-Z, a-z, blank)
Model Difference	Different in Antenna option
Adapter	Model: THX-120300KC Brand:Shenzhen Tianhangxing Electronics Co. LTd. Input: 100-240 AC (50/60Hz) Output: 12V-3A
Battery	N/A
Frequency Range	902.75MHz~ 927.25MHz
Modulation Technique	FHSS
Hardware Version	IDRO900FE V2.0
Software Version	Rfmain_2023_08_10_01_SP.idro
Connecting I/O Port(s)	Refer to the remark below.

Remark:

The above information of EUT was declared by manufacturer. Please refer to the specifications or user's manual for more detailed description.

1.4. Equipment Specification

Table for Filed Antenna

Ant.	Brand	Model Name	Antenna Name	Connector	Gain (dBi)	Antenna Cable loss (dB)	Antenna combination(dB)
1	SSI	Tarvos Pro (HRD30000)	Avior	N-Type	15	12	3
2	SSI	Tarvos Pro (HRD30000)	Avalon	N-Type	13	12	1
3	SSI	Tarvos Pro (HRD30000)	Cheetah II	N-Type	12	12	0
4	SSI	Tarvos Pro (HRD30000)	Kuma	N-Type	10	12	-2
5	SSI	Tarvos Pro (HRD30000)	Bobcat	N-Type	8	12	-4
6	SSI	Tarvos Pro (HRD30000)	Vespira	N-Type	12	12	0

Note: All antennas have been tested for conducted emission and radiated spurious emission, but report only shows the worst data of the Avior antenna.

1.5. Modification of EUT

No modifications are made to the EUT during all test items.

1.6. Laboratory Information

Company Name	: Shanghai ATBL Technology Co., Ltd.
Address	: Building 8, No.160 Basheng Road, Waigaoqiao Free Trade Zone, Pudong New Area, Shanghai
Telephone	: +86(0)21-51298625

1.7. Applicable Standards

According to the specifications of the manufacturer, the EUT must comply with the requirements of the following standards:

47 CFR Part 15 Subpart C §15.247

FCC KDB 558074 D01 15.247 Meas Guidance v05r02

ANSI C63.10-2020

Remark:

All test items were verified and recorded according to the standards and without any deviation during the test.

2. TEST CONFIGURATION OF EUT

2.1. Carrier Frequency Channel

Frequency Band	Channel	Frequency MHz	Channel	Frequency MHz
902 - 928 MHz	01	902.75	28	916.25
	02	903.25	29	916.75
	03	903.75	30	917.25
	04	904.25	31	917.75
	05	904.75	32	918.25
	06	905.25	33	918.75
	07	905.75	34	919.25
	08	906.25	35	919.75
	09	906.75	36	920.25
	10	907.25	37	920.75
	11	907.75	38	921.25
	12	908.25	39	921.75
	13	908.75	40	922.25
	14	909.25	41	922.75
	15	909.75	42	923.25
	16	910.25	43	923.75
	17	910.75	44	924.25
	18	911.25	45	924.75
	19	911.75	46	925.25
	20	912.25	47	925.75
	21	912.75	48	926.25
	22	913.25	49	926.75
	23	913.75	50	927.25
	24	914.25		
	25	914.75		
	26	915.25		
	27	915.75		

2.2. Test Modes

The table below is showing all test modes to demonstrate in compliance with the standard.

Test Mode	Description	Operation mode
Mode1	CH01	Dense reader mode
Mode 2	CH26	Dense reader mode
Mode 3	CH50	Dense reader mode
Mode 4	CH01	Single reader mode
Mode 5	CH26	Single reader mode
Mode 6	CH50	Single reader mode

Note:

- (1) The measurements are performed at all Bit Rate of Transmitter, the worst data was reported.
- (2) We tested for all available U.S. voltage and frequencies(For 120V,50/60Hz and 240V,50/60Hz) for which the device is capable of operation, and the worst case of 120V/60Hz is shown in the report.
- (3) All modes was tested in ANT 1,ANT2,ANT3,ANT4. The four antennas can't transmit simultaneously ,ANT1 test data(worst case) was recorded in the test report

For AC conducted Emission

Test case	
AC Conducted Emission	Mode 7:Keeping TX

Table of parameters of test software setting

During testing, the channel &power controlling software provided by the customer was used to control the operating channel as well as the output power level. The RF output power selection is for the setting of RF output power expected by the customer and is going to be fixed on the firmware of the final end product power parameters of FHSS.

Type	Mode or Modulation type	Power class	Software for Testing
902~928MHz	FHSS	Default	Ctest

2.3. Block Diagram of Test System

2.3.1. For AC Power-Line Conducted Emission

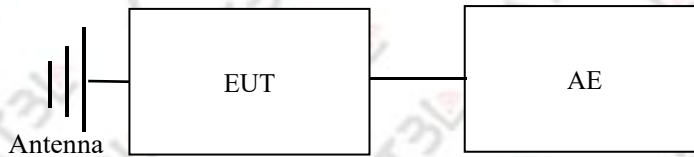

2.3.2. For Radiated Spurious Emission

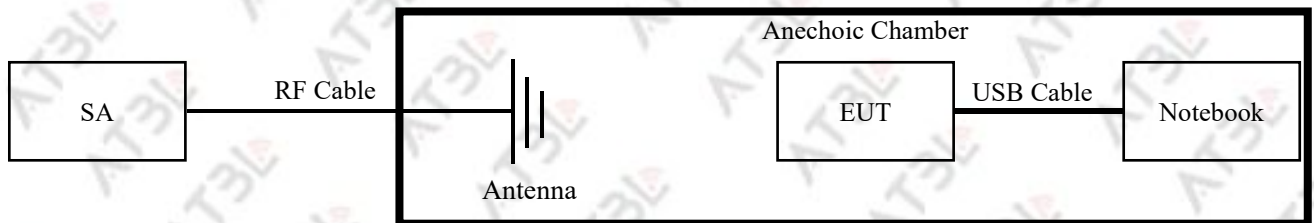

2.3.3. For Conducted Test



2.4. Description of Support Units and accessories

NO.	Unit	Manufacturer	Model	ID or Specification	Description	Note
1	PC	DELL	G15	N/A	1.2m unshielded	Support units
2	RF cable	N/A	N/A	9KHz-18GHz	1.6m shielded	Support units
3	Network cable	N/A	N/A	N/A	1.5m shielded	Support units
4	Antenna cable	N/A	N/A	N/A	10.5m shielded	Accessory

2.5. Test Software and Power Level

During the test, the channel and power control software provided by the customer is used to control the operation channel and output power level.

2.6. EUT Operating Conditions

For radiated spurious emission and conducted test, the engineering test program was provided and make the EUT to continuous transmit/receive.

2.7. Equipment List

2.7.1. For AC Power-Line Conducted Emission

Kind of Equipment	Manufacturer	Type No.	Serial No.	Equipment No.	Calibrated Until
EMI Test Receiver	R&S	ESPI	100679	SHATBL-E012	2024.05.09
LISN	R&S	ENV216	101300	SHATBL-E013	2024.05.30
LISN	R&S	ENV216	100333	SHATBL-E041	2024.05.09
CE Cable	Chuangcexing	2M	N/A	SHATBL-E014	2024.05.09
Temperature & Humidity	Deli	Deli	N/A	SHATBL-E015	2024.09.19
Testing Software	FALA	EZ-EMC(Ver.EMC-CON 3A1.1)		SHATBL-E044	N/A

2.7.2. For Radiated Spurious Emission

Equipment Name	Manufacturer	Model	Serial No.	Equipment No.	Calibration Until
Signal analyzer	Agilent	N9020A	MY50200811	SHATBL-E017	2024.07.09
Amplifier	JPT	JPA0118-55-303A	1910001800055000	SHATBL-E006	2024.07.09
Amplifier	JPT	JPA-10M1G32	21010100035001	SHATBL-E005	2024.07.09
Antenna/Turn table Controller	Brilliant	SKC1000	N/A	SHATBL-E007	N/A
Antenna Tower	Brilliant	BK-4AT-BS	N/A	SHATBL-E059	N/A
Loop Antenna	Daze	ZN30900C	20077	SHATBL-E042	2024.07.09
Bilog Antenna	SCHWARZBECK	VULB 9168	01174	SHATBL-E008	2024.07.09
Broad-band Horn Antenna	SCHWARZBECK	BBHA 9120D	02334	SHATBL-E009	2024.07.09
Horn Antenna	COM-POWER	AH-1840	10100008	SHATBL-E043	2024.07.09
Thermometer	DeLi	N/A	N/A	SHATBL-E015	2024.07.09
Test Software	FALA	EMC-RI	N/A	SHATBL-E046	N/A

2.7.3. For Conducted Test

Equipment Name	Manufacturer	Model	Serial No.	Equipment No.	Calibration Until
Signal analyzer	Agilent	N9020A	MY50200811	SHATBL-E017	2024.07.09
Attenuator	N/A	SMA-JK6G-20dB	N/A	SHATBL-E060	N/A
Power meter	keysight	U2021XA	MY55520005	SHATBL-E062	2024.07.09

2.8. Measurement Uncertainty

The reported uncertainty of measurement $y \pm U$, where expanded uncertainty U is based on a standard uncertainty multiplied by a coverage factor of $k=2$, providing a level of confidence of approximately 95 %.

No.	Item	Uncertainty
1	RF output power, conducted	$\pm 0.6\text{dB}$
2	Conducted spurious emissions	$\pm 0.6\text{dB}$
3	All emissions, radiated 30MHz-1GHz	$\pm 4.6\text{dB}$
4	All emissions, radiated 1GHz-6GHz	$\pm 5.2\text{dB}$
5	All emissions, radiated 6GHz-18GHz	$\pm 4.4\text{dB}$
6	Occupied bandwidth	4%Hz

3. TEST RESULT

3.1. Maximum Output Power

3.1.1. Limit

FCC Part 15.247 ,Subpart C				
Section	Test Item	Limit	Frequency Range (MHz)	Result
15.247 (b)(2)	Output Power	1W	902-928	Pass

3.1.2. Test Procedure

This is an RF-conducted test to evaluate maximum peak output power. Use a direct connection between the antenna port of the unlicensed wireless device and the spectrum analyzer, through suitable attenuation. The hopping shall be disabled for this test:

1. Use the following spectrum analyzer settings:

- ① Span: Approximately five times the 20 dB bandwidth, centered on a hopping channel.
- ② RBW > 20 dB bandwidth of the emission being measured.
- ③ VBW \geq RBW.
- ④ Sweep: Auto.
- ⑤ Detector function: Peak.
- ⑥ Trace: Max hold.

2. Allow trace to stabilize.

3. Use the marker-to-peak function to set the marker to the peak of the emission.

4. The indicated level is the peak output power, after any corrections for external attenuators and cables.

5. A plot of the test results and setup description shall be included in the test report.

Remark:

A peak responding power meter may be used, where the power meter and sensor system video bandwidth is greater than the occupied bandwidth of the unlicensed wireless device, rather than a spectrum analyzer.

3.1.3. Test Setup

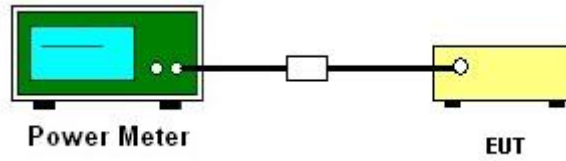

3.1.4. Test Result of Maximum Peak Conducted Output Power

Please refer to the Appendix A.

3.2. Number of Hopping Frequencies

3.2.1. Limit

For frequency hopping systems operating in the 902-9028MHz band:if the 20dB bandwidth of the hopping channel is less than 250kHz,the system shall use at least 50 hopping frequencies and the average time of occupancy on any frequency shall not be greater than 0.4 seconds within a 20 second period; if the 20dB bandwidth of the hopping channel is 250kHz or greater, the system shall use at least 25 hopping frequencies and the average time of occupancy on any frequency shall not be greater than 0.4 seconds within a 10 second period.The maximum allowed 20dB bandwidth of the hopping channel is 500kHz.

3.2.2. Test Procedure

The EUT shall have its hopping function enabled. Use the following spectrum analyzer settings:

1. Span: The frequency band of operation. Depending on the number of channels the device supports, it may be necessary to divide the frequency range of operation across multiple spans, to allow the individual channels to be clearly seen.

2. RBW: To identify clearly the individual channels, set the RBW to less than 30% of the channel spacing or the 20 dB bandwidth, whichever is smaller.

3. VBW \geq RBW.

4. Sweep: Auto.

5. Detector function: Peak.

6. Trace: Max hold.

7. Allow the trace to stabilize.

It might prove necessary to break the span up into sub ranges to show clearly all of the hopping frequencies. Compliance of an EUT with the appropriate regulatory limit shall be determined for the number of hopping channels. A plot of the data shall be included in the test report.

3.2.3. Test Setup

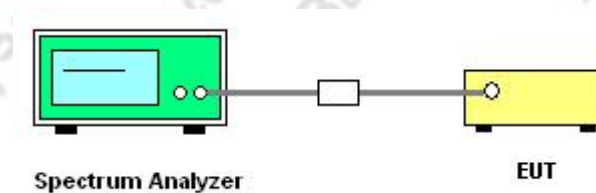

3.2.4. Test Result of Number of Hopping Frequencies

Please refer to the Appendix A.

3.3. Average Time Occupancy

3.3.1. Limit

47 CFR 15.247(a)(1)(i): The average time of occupancy on any channel shall not be greater than 0.4 seconds within a period of 20 seconds.

3.3.2. Test Procedure

The EUT shall have its hopping function enabled. Use the following spectrum analyzer settings:

1. Span: Zero span, centered on a hopping channel.
2. RBW shall be \leq channel spacing and where possible RBW should be set $\gg 1 / T$, where T is the expected dwell time per channel.
3. Sweep: As necessary to capture the entire dwell time per hopping channel; where possible use a video trigger and trigger delay so that the transmitted signal starts a little to the right of the start of the plot. The trigger level might need slight adjustment to prevent triggering when the system hops on an adjacent channel; a second plot might be needed with a longer sweep time to show two successive hops on a channel.
4. Detector function: Peak.
5. Trace: Max hold.
6. Use the marker-delta function to determine the transmit time per hop.
7. The average time of occupancy is calculated from the transmit time per hop multiplied by the number of hops in the period specified in the requirements.

3.3.3. Test Setup

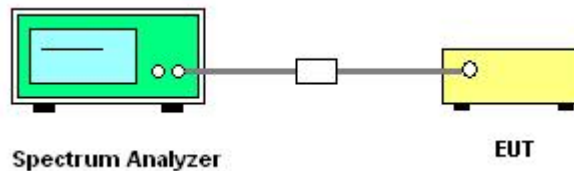

3.3.4. Test Result of Duty Cycle and Dwell Time

Please refer to the Appendix A.

3.4. 20dB Bandwidth

3.4.1. Limit

FCC Part15.247 Subpart C				
Section	Test Item	Limit	Frequency Range (MHz)	Result
15.247(a)(1)(i)	20dB Bandwidth	500kHz	902-928	pass

3.4.2. Test Procedure

1. The RF output of EUT was connected to the spectrum analyzer by RF cable and attenuator. The path loss was compensated to the results for each measurement.
2. Set to the maximum power setting and enable the EUT transmit continuously.
3. Use the following spectrum analyzer settings for 20dB Bandwidth measurement. Span = approximately 2 to 3 times the 20 dB bandwidth, centered on a hopping channel; RBW \geq 1% of the 20 dB bandwidth; VBW \geq RBW; Sweep = auto; Detector function = peak; Trace = max hold.
4. Measure and record the results in the test report.

3.4.3. Test Setup

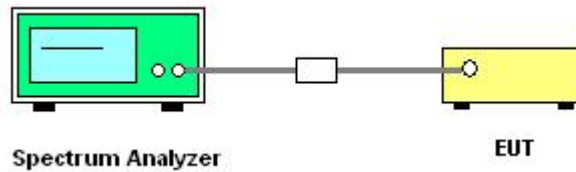

3.4.4. Test Result of 20dB Bandwidth

Please refer to the Appendix A.

3.5. Carrier Frequency Separation

3.5.1. Limit

47 CFR 15.247(a)(1): Frequency hopping systems shall have hopping channel carrier frequencies that are separated by a minimum of 25 kHz or the 20 dB bandwidth of the hopping channel, whichever is greater.

3.5.2. Test Procedure

The EUT shall have its hopping function enabled. Use the following spectrum analyzer settings:

1. Span: Wide enough to capture the peaks of two adjacent channels.
2. RBW: Start with the RBW set to approximately 30% of the channel spacing; adjust as necessary to best identify the center of each individual channel.
3. VBW \geq RBW.
4. Sweep: Auto.
5. Detector function: Peak.
6. Trace: Max hold.
7. Allow the trace to stabilize.
8. Use the marker-delta function to determine the separation between the peaks of the adjacent channels. A plot of the data shall be included in the test report.

3.5.3. Test Setup

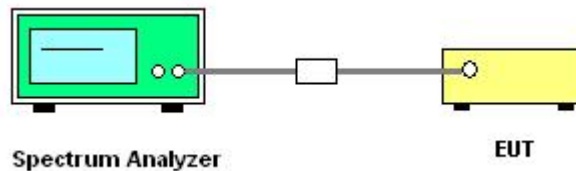

3.5.4. Test Result of Carrier Frequency Separation

Please refer to the Appendix A.

3.6. Conducted Band Edge

3.6.1. Limit

47 CFR 15.247(d): In any 100 kHz bandwidth outside the frequency band in which the spread spectrum or digitally modulated intentional radiator is operating, the radio frequency power that is produced by the intentional radiator shall be at least 20 dB below that in the 100 kHz bandwidth within the band that contains the highest level of the desired power, based on either an RF conducted or a radiated measurement, provided the transmitter demonstrates compliance with the peak conducted power limits.

3.6.2. Test Procedure

1. Set to the maximum power setting and enable the EUT transmit continuously.
2. Set RBW = 100kHz, VBW = 300kHz. Band edge emissions must be at least 20 dB down from the highest emission level within the authorized band as measured with a 100kHz RBW. The attenuation shall be 30 dB instead of 20 dB when RMS conducted output power procedure is used.
3. Enable hopping function of the EUT and then repeat step 2. and 3.
4. Measure and record the results in the test report.

3.6.3. Test Setup

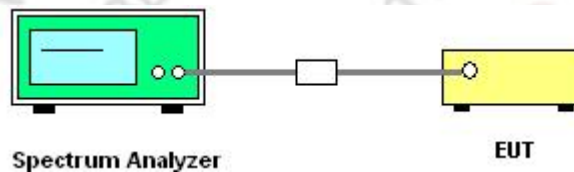

3.6.4. Test Result of Conducted Band Edge

Please refer to the Appendix A.

3.7. Conducted Spurious Emission

3.7.1. Limit

47 CFR 15.247(d): In any 100 kHz bandwidth outside the frequency band in which the spread spectrum or digitally modulated intentional radiator is operating, the radio frequency power that is produced by the intentional radiator shall be at least 20 dB below that in the 100 kHz bandwidth within the band that contains the highest level of the desired power, based on either an RF conducted or a radiated measurement, provided the transmitter demonstrates compliance with the peak conducted power limits.

3.7.2. Test Procedure

1. The RF output of EUT was connected to the spectrum analyzer by RF cable and attenuator. The path loss was compensated to the results for each measurement.
2. Set to the maximum power setting and enable the EUT transmit continuously.
3. Set RBW = 100 kHz, VBW = 300kHz, scan up through 10th harmonic. All harmonics / spurs must be at least 20 dB down from the highest emission level within the authorized band as measured with a 100 kHz RBW.
4. Measure and record the results in the test report.
5. The RF fundamental frequency should be excluded against the limit line in the operating frequency band.

3.7.3. Test Setup

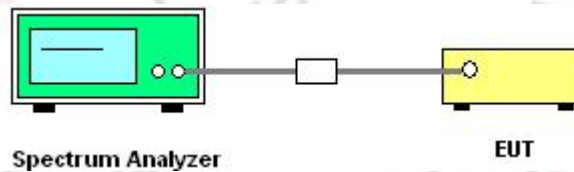

3.7.4. Test Result of Conducted Spurious Emission

Please refer to the Appendix A.

Note: 1 only worst case was recorded in the test report, if no any others

2 have more than 20dB enough margin was no recorded in the test report.

3.8. Radiated Spurious Emission and Restricted Band

3.8.1. Limit

47 CFR 15.247(d): In any 100 kHz bandwidth outside the frequency band in which the spread spectrum or digitally modulated intentional radiator is operating, the radio frequency power that is produced by the intentional radiator shall be at least 20 dB below that in the 100 kHz bandwidth within the band that contains the highest level of the desired power, based on either an RF conducted or a radiated measurement, provided the transmitter demonstrates compliance with the peak conducted power limits.

47 CFR 15.205(a): Only spurious emissions are permitted in any of the frequency bands listed below:

Frequency (MHz)	Frequency (MHz)	Frequency (MHz)	Frequency (MHz)	Frequency (MHz)
0.090-0.110	12.29-12.293	149.9-150.05	1660-1710	8.025-8.5
0.495-0.505	12.51975-12.52025	156.52475-156.52525	1718.8-1722.2	9.0-9.2
2.1735-2.1905	12.57675-12.57725	156.7-156.9	2200-2300	9.3-9.5
4.125-4.128	13.36-13.41	162.0125-167.17	2310-2390	10.6-12.7
4.17725-4.17775	16.42-16.423	167.72-173.2	2483.5-2500	13.25-13.4
4.20725-4.20775	16.69475-16.69525	240-285	2690-2900	14.47-14.5
6.215-6.218	16.80425-16.80475	322-335.4	3260-3267	15.35-16.2
6.26775-6.26825	25.5-25.67	399.9-410	3332-3339	17.7-21.4
6.31175-6.31225	37.5-38.25	608-614	3345.8-3358	22.01-23.12
8.291-8.294	73-74.6	960-1240	3600-4400	23.6-24.0
8.362-8.366	74.8-75.2	1300-1427	4500-5150	31.2-31.8
8.37625-8.38675	108-121.94	1435-1626.5	5350-5460	36.43-36.5
8.41425-8.41475	123-138	1645.5-1646.5	7250-7750	Above 38.6

47 CFR 15.209(a): The emissions from an intentional radiator shall not exceed the field strength levels specified in the following table:

Frequency (MHz)	Field strength (microvolts/meter)	Measurement distance (meters)
0.009-0.490	2400/F(kHz)	300
0.490-1.705	24000/F(kHz)	30
1.705-30.0	30	30
30-88	100	3
88-216	150	3
216-960	200	3
Above 960	500	3

3.8.2. Test Procedure

1. The EUT was placed on a turntable with 0.8 meter for frequency below 1GHz and 1.5 meter for frequency above 1GHz respectively above ground.

2. The EUT was set 3 meters from the interference receiving antenna, which was mounted on the top of a variable height antenna tower.

3. For each suspected emission, the EUT was arranged to its worst case and then tune the Antenna tower (from 1 m to 4 m) and turntable (from 0 degree to 360 degrees) to find the maximum reading. A pre-amp and a high pass filter are used for the test in order to get better signal level to comply with the guidelines.

4. Set to the maximum power setting and enable the EUT transmit continuously.

5. Use the following spectrum analyzer settings:

① Span shall wide enough to fully capture the emission being measured;

② Set RBW=100 kHz for $f < 1$ GHz, RBW=1MHz for $f > 1$ GHz ; VBW \geq RBW; Sweep = auto;

Detector function = peak; Trace = max hold for peak;

6. For testing below 1GHz, if the emission level of the EUT in peak mode was 3 dB lower than the limit specified, then peak values of EUT will be reported, otherwise, the emissions will be repeated one by one using the CISPR quasi-peak method and reported.

7. For testing above 1GHz, the emission level of the EUT in peak mode was 20dB lower than peak limit (that means the emission level in average mode also complies with the limit in average mode), then peak values of EUT will be reported, otherwise, the emissions will be measured in average mode again and reported.

3.8.3. Test Setup

3.8.3.1. For radiated emissions below 30MHz

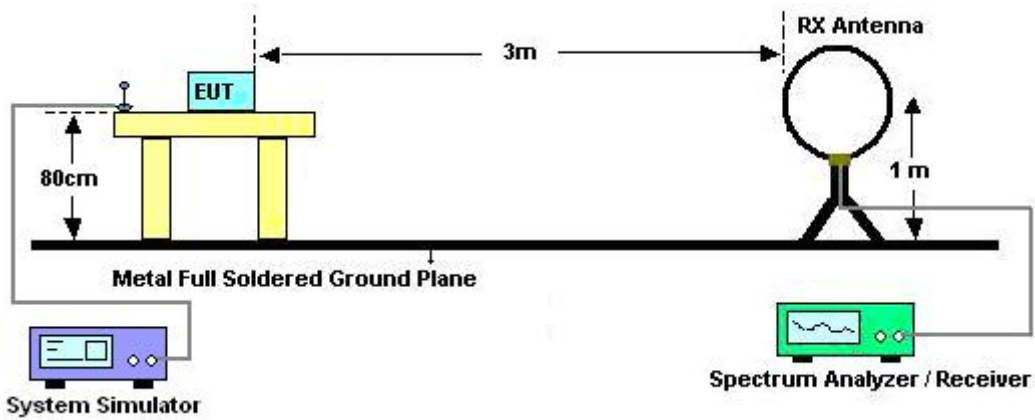

3.8.3.2. For radiated emissions from 30MHz to 1GHz

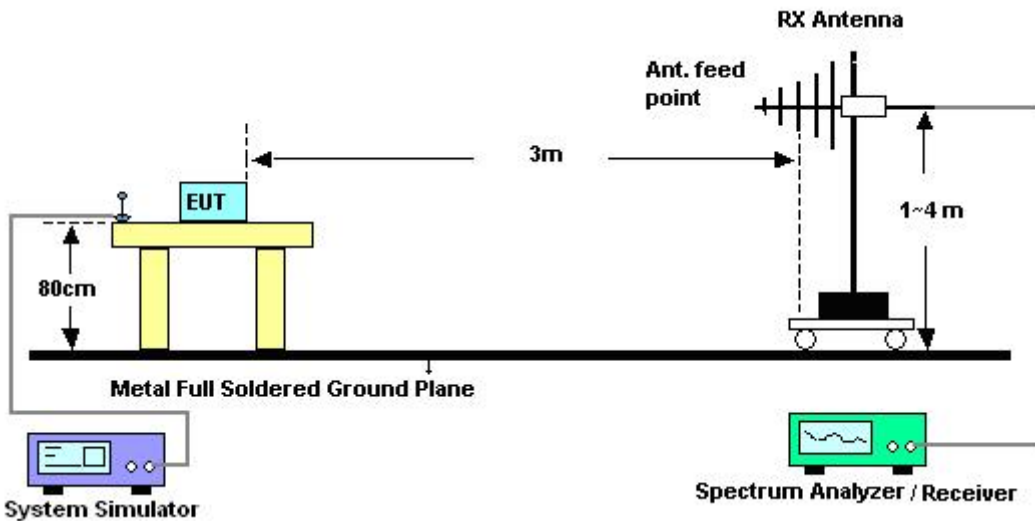

3.8.3.3. For radiated emissions above 1GHz

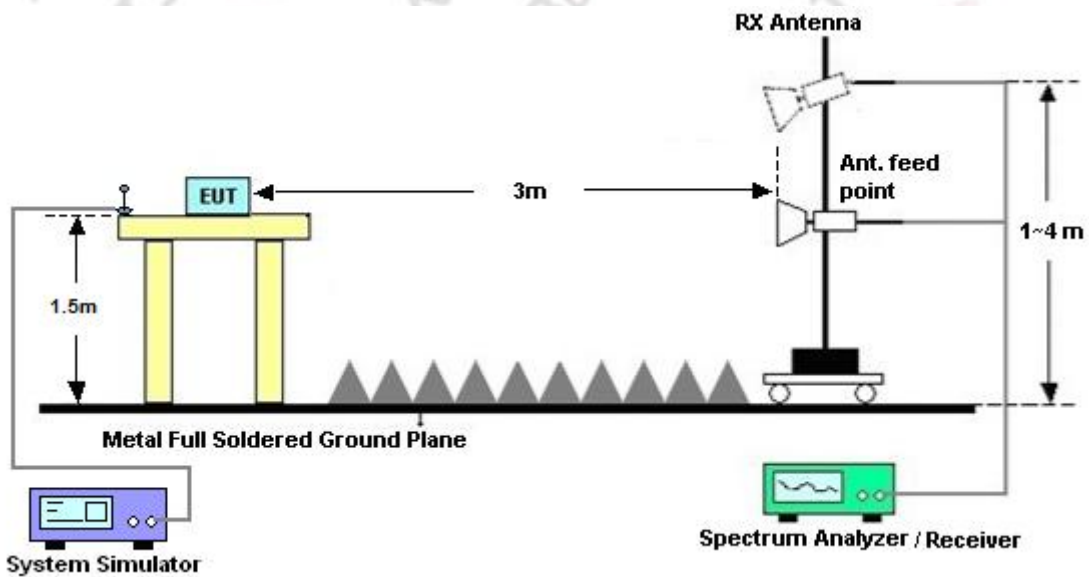

3.8.4. Test Result of Radiated Spurious Emission

3.8.4.1. For 9 kHz ~ 30 MHz

Please refer to the Appendix B.

3.8.4.2. For 30 MHz ~ 1 GHz

Please refer to the Appendix B.

3.8.4.3. For 1 GHz ~ 18GHz

Please refer to the Appendix B.

3.8.5. Test Result of Restricted Band

Please refer to the Appendix B.

Note: only worst case was recorded in the test report

have more than 20dB enough margin was no recorded in the test report.

3.9. AC Power-Line Conducted Emission

3.9.1. Limit

47 CFR 15.207(a): For an intentional radiator that is designed to be connected to the public utility (AC) power line, the radio frequency voltage that is conducted back onto the AC power line on any frequency or frequencies, within the band 150 kHz to 30 MHz, shall not exceed the limits in the following table:

Frequency of emission (MHz)	Conducted limit (dB μ V)	
	Quasi-peak	Average
0.15-0.5	66 to 56*	56 to 46*
0.5-5	56	46
5-30	60	50

*Decreases with the logarithm of the frequency.

3.9.2. Test Procedure

1. The EUT was placed 0.4 meter from the conducting wall of the shielding room was kept at least 80 centimeters from any other grounded conducting surface.
2. Connect EUT to the power mains through a line impedance stabilization network (LISN).
3. All the support units are connecting to the other LISN.
4. The LISN provides 50 ohm coupling impedance for the measuring instrument.
5. The FCC states that a 50 ohm, 50 microhenry LISN should be used.
6. Both sides of AC line were checked for maximum conducted interference.
7. The frequency range from 150 kHz to 30 MHz was searched.
8. Set the test-receiver system to Peak Detect Function and specified bandwidth (IF Bandwidth = 9 kHz) with Maximum Hold Mode. Then measurement is also conducted by Average Detector and Quasi-Peak Detector Function respectively.

3.9.3. Test Setup

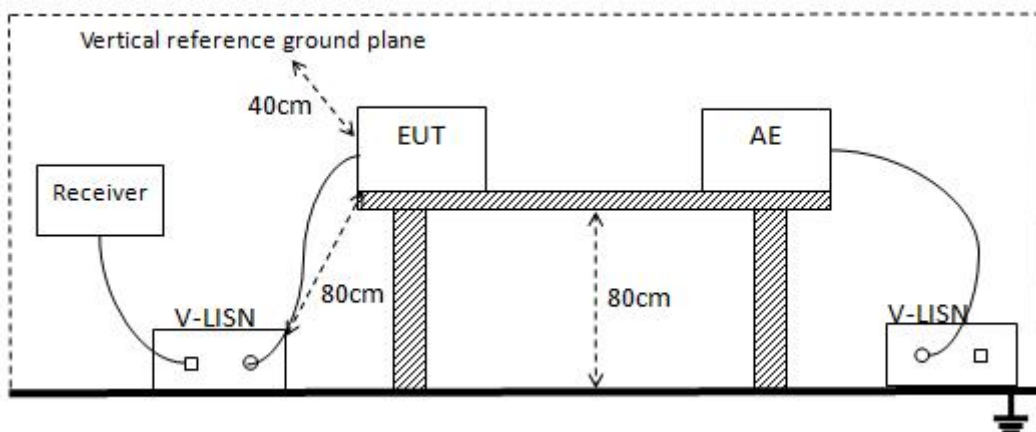

3.9.4. Test Result of AC Power-Line Conducted Emission

Please refer to the Appendix B.

3.10. Antenna Requirement

3.10.1. Standard Requirement

According to 47 CFR 15.203, an intentional radiator shall be designed to ensure that no antenna other than that furnished by the responsible party shall be used with the device.

3.10.2. EUT Antenna

The EUT Antenna should be installed by professional installer only so that the limits in this part do not exceed.

4. TEST SETUP PHOTOGRAPHS

Please refer to the Appendix C.

5. PHOTOGRAPHS OF EUT

Please refer to the Appendix D.

*****END OF THE REPORT*****