

FCC 47 CFR PART 15 SUBPART C

Product Type : Smart Watch
Applicant : Kronoz LLC
Address : Route de Valavran 96, 1294 Genthod, Switzerland
Trade Name : MyKronoz
Model Number : ZeCircle
Test Specification : FCC 47 CFR PART 15 SUBPART C: Oct., 2013
ANSI C63.10:2013

Receive Date : 9 February, 2015
Test Period : 12 February, 2015 to 19 March, 2015
Issue Date : 20 March, 2015

Issue by

A Test Lab Techno Corp.
No. 140-1, Changan Street, Bade City,
Taoyuan County 334, Taiwan R.O.C.
Tel : +886-3-2710188 / Fax : +886-3-2710190



Taiwan Accreditation Foundation accreditation number: 1330

Note: This report shall not be reproduced except in full, without the written approval of A Test Lab Techno Corp. This document may be altered or revised by A Test Lab Techno Corp. personnel only, and shall be noted in the revision section of the document. The client should not use it to claim product endorsement by TAF, or any government agencies. The test results in the report only apply to the tested sample.

Revision History

Rev.	Issue Date	Revisions	Revised By
00	20 March, 2015	Initial Issue	



Verification of Compliance

Issued Date: 03/20/2015

Product Type : Smart Watch
 Applicant : Kronoz LLC
 Address : Route de Valavran 96, 1294 Genthod, Switzerland
 Trade Name : MyKronoz
 Model Number : ZeCircle
 FCC ID : 2AA7D-ZECE1
 EUT Rated Voltage : DC 3.7V battery, DC 5.0V USB charge,
 Test Voltage : DC5V From PC input 120 Vac / 60 Hz
 Applicable Standard : FCC 47 CFR PART 15 SUBPART C: Oct., 2013
 ANSI C63.10:2013

Test Result : Complied

Test Laboratory : Site 1:
 A Test Lab Techno Corp.
 No. 140-1, Changan Street, Bade City,
 Taoyuan County 334, Taiwan R.O.C.
 Tel : +886-3-2710188 / Fax : +886-3-2710190
Taiwan Accreditation Foundation accreditation number: 1330

Site 2:
 Shenzhen Academy of Metrology and Quality Inspection
 No.4 TongFa Road, Xili Town Nanshan District, Shenzhen,
 China

The above equipment was tested by A Test Lab Techno Corp. The test data, data evaluation, test procedures, and equipment configurations shown in this report were made in accordance with the procedures given in ANSI C63.10: 2013 and KDB 558074, and the energy emitted by the sample tested as described in this report is in compliance with the requirements of FCC Rules Part 15.207, 15.209, 15.247 .The test results of this report relate only to the tested sample identified in this report.

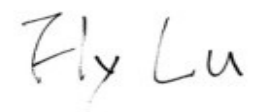
Approved By :  Reviewed By : 

(Manager) _____ (Murphy Wang) (Testing Engineer) _____ (Fly Lu)



TABLE OF CONTENTS

1 General Information6

2 EUT Description.....7

3 Test Methodology.....8

3.1. Mode of Operation 8

3.2. EUT Exercise Software..... 8

3.3. Configuration of Test System Details 9

3.4. Test Site Environment..... 10

4 Conducted Emission Measurement.....11

4.1. Limit.....11

4.2. Test Instruments11

4.3. Test Setup.....11

4.4. Test Procedure..... 12

4.5. Test Result..... 13

5 Radiated Emission Measurement15

5.1. Limit..... 15

5.2. Test Instruments 15

5.3. Setup 16

5.4. Test Procedure..... 17

5.5. Test Result..... 19

6 Maximum Conducted Output Power Measurement.....23

6.1. Limit..... 23

6.2. Test Setup..... 23

6.3. Test Instruments 23

6.4. Test Procedure..... 23

6.5. Test Result..... 24

7 6dB RF Bandwidth and 99 % Occupied Bandwidth Measurement.....25

7.1. Limit..... 25

7.2. Test Setup..... 25

7.3. Test Instruments 25

7.4. Test Procedure..... 25

7.5. Test Result..... 26

7.6. Test Graphs 27

8 Maximum Power Density Measurement28



8.1. Limit.....	28
8.2. Test Setup.....	28
8.3. Test Instruments	28
8.4. Test Procedure.....	28
8.5. Test Result.....	29
8.6. Test Graphs	30
9 Out of Band Conducted Emissions Measurement	31
9.1. Limit.....	31
9.2. Test Setup.....	31
9.3. Test Instruments	31
9.4. Test Procedure.....	31
9.5. Test Graphs	32
10 Band Edges Measurement.....	33
10.1. Limit.....	33
10.2. Test Setup.....	33
10.3. Test Instruments	33
10.4. Test Procedure.....	34
10.5. Test Result.....	35
11 Antenna Measurement	39
11.1. Limit.....	39
11.2. Antenna Connector Construction.....	39
12 RF EXPOSURE.....	40

1 General Information

1.1 Summary of Test Result

Item	Result	Remark
AC Power Conducted Emission	PASS	A PC was used for charging
Transmitter Radiated Emissions	PASS	Radiated method
Max. Output Power	PASS	Conducted method
6dB RF Bandwidth	PASS	Conducted method
Power Spectral Density	PASS	Conducted method
Out of Band Conducted Spurious Emission	PASS	Conducted method
Band Edge Measurement	PASS	Conducted method
Occupied Bandwidth Measurement	PASS	Conducted method
Antenna Requirement	PASS	-----

The test results of this report relate only to the tested sample(s) identified in this report. Manufacturer or whom it may concern should recognize the pass or fail of the test result.

1.2 Measurement Uncertainty

Test Item	Frequency Range	Uncertainty (dB)	
Conducted Emission	9kHz ~ 30MHz	± 2.02	
Radiated Emission	9kHz ~ 30MHz	± 3.14	
	30MHz ~ 1000MHz	Horizontal	± 3.98
		Vertical	± 3.62
	1000MHz ~ 18000MHz	Horizontal	± 3.11
		Vertical	± 3.07
	18000MHz ~ 40000MHz	Horizontal	± 3.66
Vertical		± 3.54	



2 EUT Description

Product Type	Smart Watch
Trade Name	MyKronoz
Model No.	ZeCircle
Applicant	Kronoz LLC. Route De Valavran 96,1294 Genthod,Switzerland.
Manufacturer	Kronoz LLC. Route De Valavran 96,1294 Genthod,Switzerland.
FCC ID	2AA7D-ZECE1
Frequency Range	Bluetooth v4.0 LE: 2402 ~ 2480 MHz
Modulation Type	Bluetooth v4.0 LE: GFSK
Antenna Type	Multilayer Chip Antenna
Antenna Gain	Bluetooth: 0.65 dBi
RF Output Power	Bluetooth v4.0 LE: 0.982mW / -0.08 dBm
99 % Occupied Bandwidth	Bluetooth v4.0 LE: 1.0836 MHz

3 Test Methodology

3.1. Mode of Operation

Decision of Test ATL has verified the construction and function in typical operation. All the test modes were carried out with the EUT in normal operation, which was shown in this test report and defined as:

Test Mode
Mode 1: Normal Operation Mode
Mode 2: Bluetooth v4.0 LE Link Mode

Software used to control the EUT for staying in continuous transmitting mode was programmed.

After verification, all tests were carried out with the worst case test modes as shown below except radiated spurious emission below 1GHz and power line conducted emissions below 30MHz, which worst case was in normal link mode only.

By preliminary testing and verifying three axis (X, Y and Z) position of EUT transmitted status, it was found that "X axis" position was the worst, then the final test was executed the worst condition and test data were recorded in this report.

3.2. EUT Exercise Software

1	Setup the EUT and assistant equipment as shown on 3.3
2	Turn on the power of all equipment.
3	Make EUT into continue transmitting mode or receiving mode under the help of PC software.

3.3. Configuration of Test System Details

Conducted Emissions

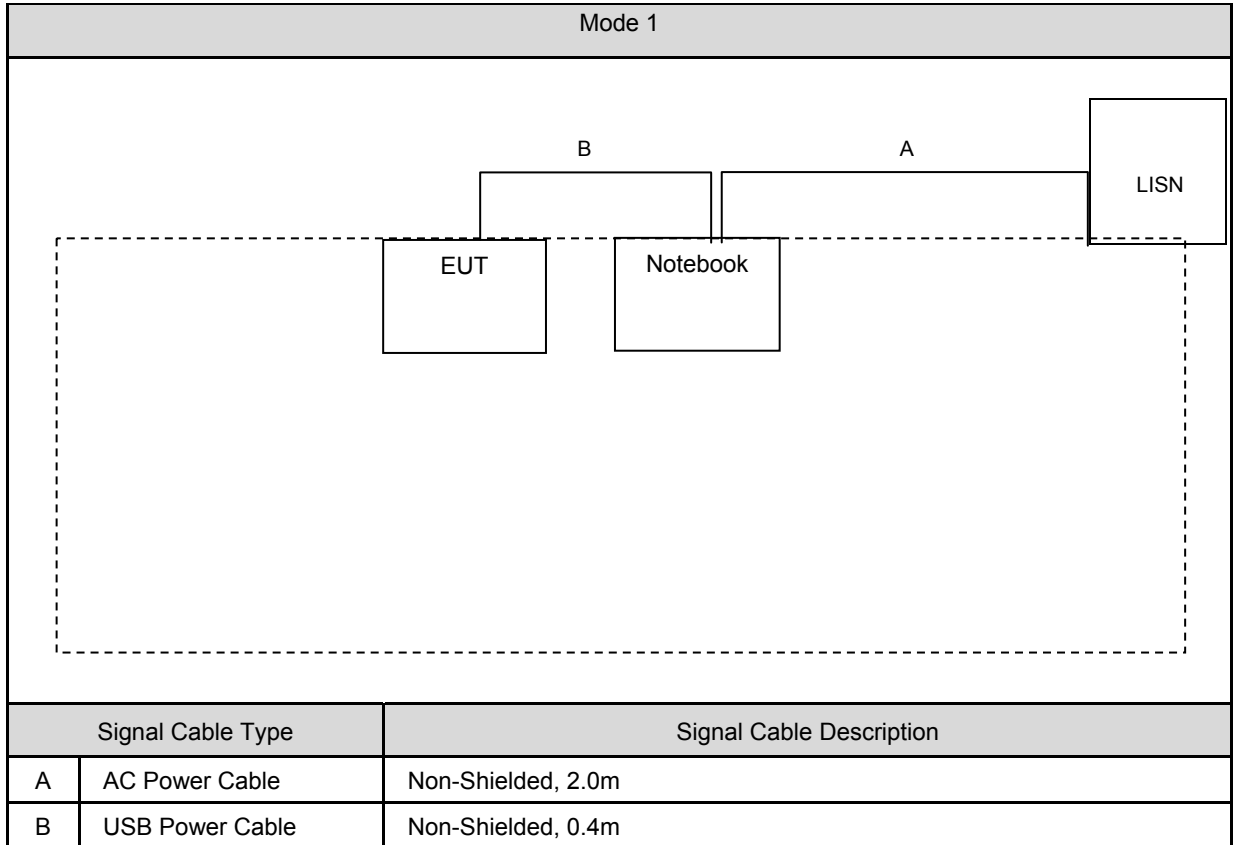



Radiated Emissions

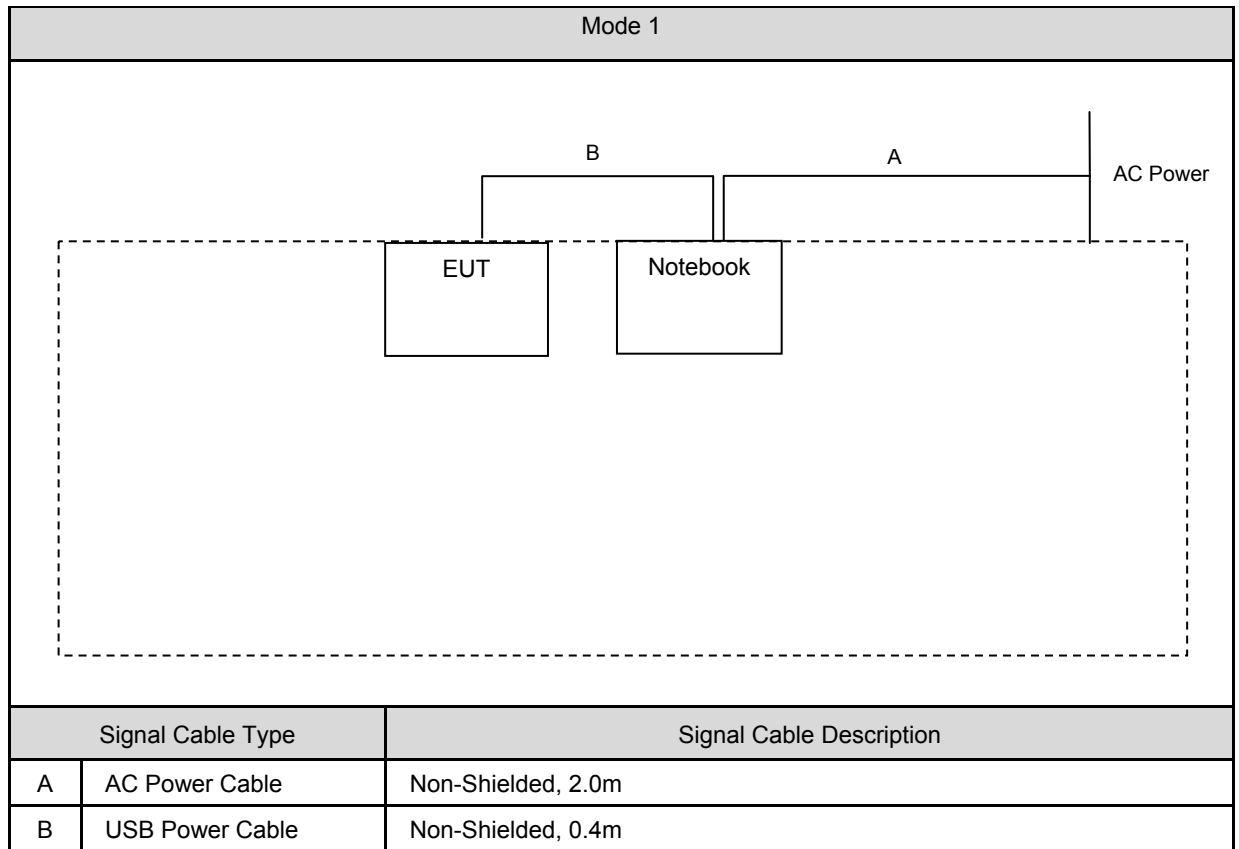

3.4. Test Site Environment

Items	Required (IEC 60068-1)	Actual
Temperature (°C)	15-35	26
Humidity (%RH)	25-75	60
Barometric pressure (mbar)	860-1060	950

4 Conducted Emission Measurement

4.1. Limit

Frequency (MHz)	Quasi-peak	Average
0.15 - 0.5	66 to 56	56 to 46
0.50 - 5.0	56	46
5.0 - 30.0	60	50

4.2. Test Instruments

Describe	Manufacturer	Model Number	Serial Number	Cal. Date	Remark
SB3319	EMI Test Receiver	Rohde & Schwarz	ESCS30	Jan.20,2015	1 Year
SB4357	AMN	Rohde & Schwarz	ENV216	Jan.20,2015	1 Year

Remark: (1) Calibration period 1 year. (2) Calibration period 2 years. (3) Calibration period 3 years.

Note: N.C.R. = No Calibration Request.

4.3. Test Setup

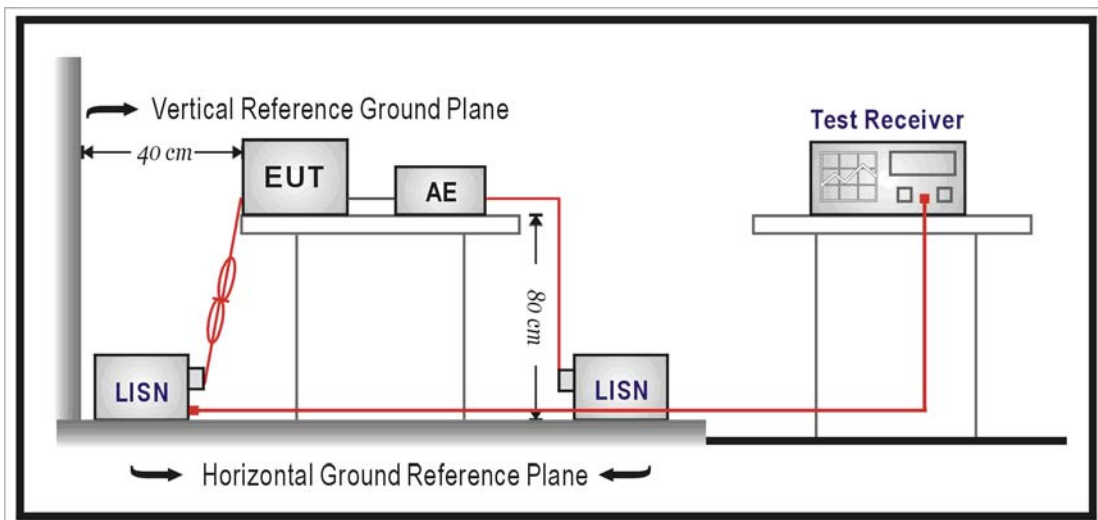

4.4. Test Procedure

The power line conducted emission measurements were performed in a shielded enclosure. The EUT was assembled on a wooden table which is 80 centimeters high, was placed 40 centimeters from the back wall and at least 1 meter from the sidewall.

Power was fed to the EUT from the public utility power grid through a line filter and EMCO Model 3162/2 SH Line Impedance Stabilization Networks (LISN). The LISN housing, measuring instrumentation case, ground plane, etc., were electrically bonded together at the same RF potential. The Spectrum analyzer was connected to the AC line through an isolation transformer. The 50-ohm output of the LISN was connected to the spectrum analyzer directly. Conducted emission levels were in the CISPR quasi-peak detection mode. The analyzer's 6 dB bandwidth was set to 9 KHz. No post-detector video filter was used.

The spectrum was scanned from 150 KHz to 30 MHz. The physical arrangement of the test system and associated cabling was varied (within the scope of arrangements likely to be encountered in actual use) to determine the effect on the unit's emanations in amplitude and frequency. All spurious emission frequencies were observed. The highest emission amplitudes relative to the appropriate limit were measured and have been recorded in paragraph 4.1.



4.5. Test Result

Standard:	FCC Part 15C	Line:	L1
Test item:	Conducted Emission	Power:	AC 120V/60Hz
Model Number:	ZeCircle	Temp.(°C)/Hum.(%RH):	20(°C)/39%RH
Mode:	1	Date:	11/02/2015
		Test By:	Eric Ou Yang
Description:			

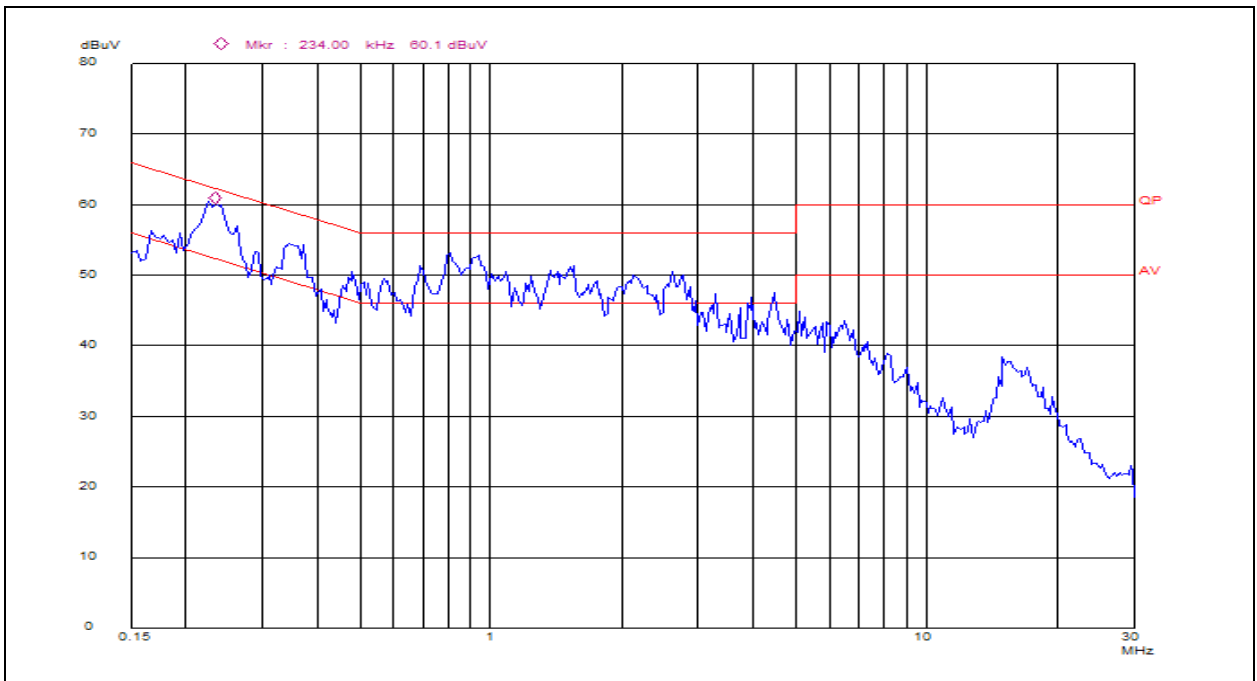

	Frequency (MHz)	Quasi-Peak		Average	
		Emission Level	Limits(dBμV)	Emission Level	Limits(dBμV)
Line	0.242	54.8	62.0	48.1	52.0
	0.350	49.7	59.0	42.4	49.0
	0.526	44.0	56.0	34.0	46.0
	1.018	43.1	56.0	34.9	46.0
	2.778	51.3	56.0	33.7	46.0
	/	/	/	/	/



Standard:	FCC Part 15C	Line:	N
Test item:	Conducted Emission	Power:	AC 120V/60Hz
Model Number:	ZeCircle	Temp.(°C)/Hum.(%RH):	20(°C)/39%RH
Mode:	1	Date:	11/02/2015
		Test By:	Eric Ou Yang
Description:			

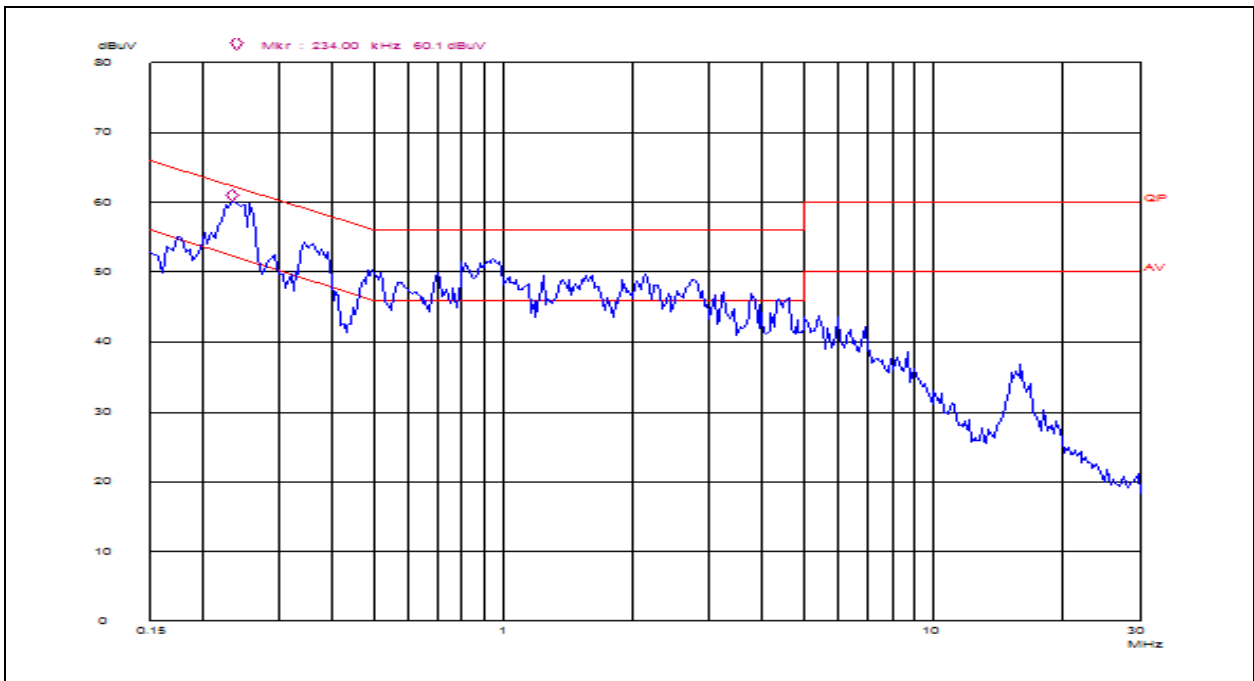

	Frequency (MHz)	Quasi-Peak		Average	
		Emission Level	Limits(dBµV)	Emission Level	Limits(dBµV)
Neutral	0.230	55.2	62.4	49.3	52.4
	0.354	49.5	58.9	42.4	48.9
	0.482	44.1	56.3	33.1	46.3
	0.698	44.6	56.0	35.5	46.0
	0.946	45.8	56.0	37.1	46.0
	2.622	40.6	56.0	33.4	46.0

5 Radiated Emission Measurement

5.1. Limit

According to §15.209(a), except as provided elsewhere in this subpart, the emissions from an intentional radiator shall not exceed the field strength levels specified in the following table:

Frequency (MHz)	Field Strength ($\mu\text{V}/\text{m}$ at meter)	Measurement Distance (meters)
0.009 – 0.490	2400 / F (kHz)	300
0.490 – 1.705	24000 / F (kHz)	30
1.705 – 30.0	30	30
30 - 88	100**	3
88-216	150**	3
216-960	200**	3
Above 960	500	3

** Except as provided in paragraph (g), fundamental emissions from intentional radiators operating under this Section shall not be located in the frequency bands 54-72 MHz, 76-88 MHz, 174-216 MHz or 470-806 MHz. However, operation within these frequency bands is permitted under other sections of this Part, e.g., Sections 15.231 and 15.241.

5.2. Test Instruments

3 Meter Chamber					
Model No.	Equipment	Manufacturer	Serial Number	Cal. Date	Remark
ESU40	EMI Test Receiver	R&S	SB8501/09	May.16, 2014	1 Year
VULB9163	Bilog Antenna	Schwarzbeck	SB8501/04	Jan.20, 2015	1 Year
HF906	Horn Antenna	R&S	SB3435	Jan.20, 2015	1 Year
--	Amplifier(1-18GHz)	R&S	SB3435/01	Jan.20, 2015	1 Year
--	Amplifier(18-40GHz)	R&S	SB3435/02	May.16, 2014	1 Year
AT4560	Horn Antenna	Amplifier Research	SB5392/02	May.16, 2014	1 Year
9X6X6	3m Semi-anechoic chamber	Albatross Projects	SB3450/01	Oct.12, 2013	2 Years
ESI26	EMI Test Receiver	Rohde & Schwarz	SB3436	Jan.20,2015	1 Year
VULB9163	Broadband antenna	SCHWARZBECK	SB3955	Jan.20,2015	1 Year
HF907	Horn Antenna	R&S	SB8501/01	Aug.15,2014	1 Year

Remark: (1) Calibration period 1 year. (2) Calibration period 2 years. (3) Calibration period 3 years.

Note: N.C.R. = No Calibration Request.

5.3. Setup

Below 1GHz

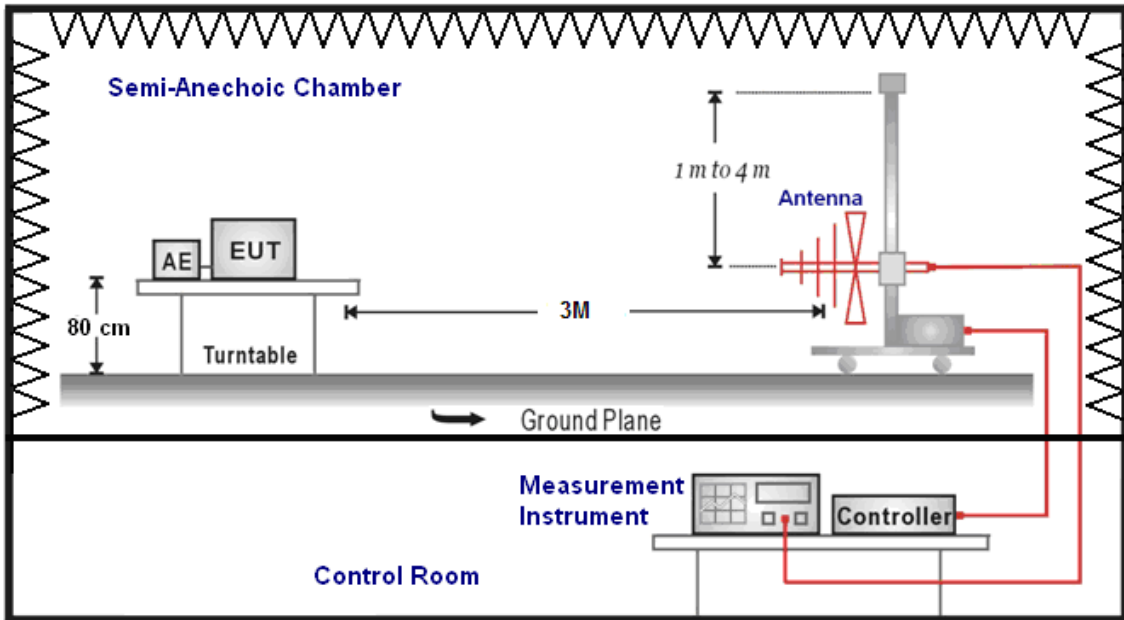

Above 1GHz

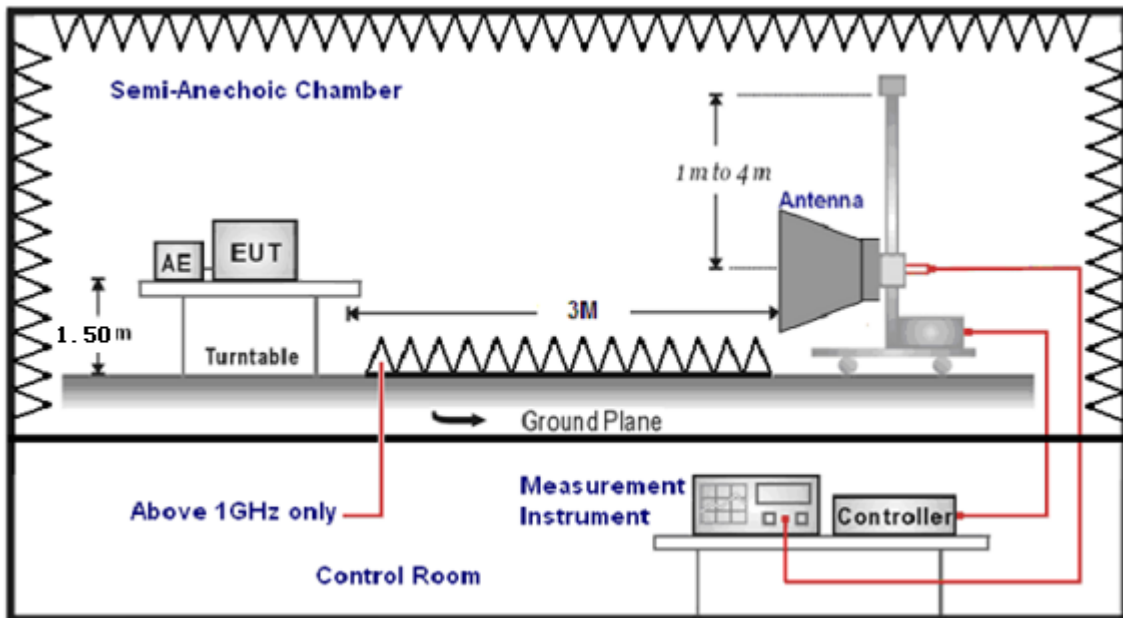

5.4. Test Procedure

Final radiation measurements were made on a three-meter, Semi Anechoic Chamber. The EUT system was placed on a nonconductive turntable which is 1.5 meters height, top surface 1.0 x 1.5 meter. The spectrum was examined from 250 MHz to 2.5 GHz in order to cover the whole spectrum below 10th harmonic which could generate from the EUT. During the test, EUT was set to transmit continuously & Measurements spectrum range from 9 kHz to 26.5 GHz is investigated.

For measurements below 1 GHz the resolution bandwidth is set to 100 kHz for peak detection measurements or 120 kHz for quasi-peak detection measurements. Peak detection is used unless otherwise noted as quasi-peak.

For measurements above 1 GHz the resolution bandwidth is set to 1 MHz, and then the video bandwidth is set to 1 MHz for peak measurements and 10 Hz for average measurements.

A nonconductive material surrounded the EUT to supporting the EUT for standing on three orthogonal planes. At each condition, the EUT was rotated 360 degrees, and the antenna was raised and lowered from one to four meters to find the maximum emission levels. Measurements were taken using both horizontal and vertical antenna polarization.

SCHWARZBECK MESS-ELEKTRONIK Biconilog Antenna (mode VULB9163) at 3 Meter and the SCHWARZBECK Double Ridged Guide Antenna (model BBHA9120D&9170) was used in frequencies 1 – 26.5 GHz at a distance of 1 meter. All test results were extrapolated to equivalent signal at 3 meters utilizing an inverse linear distance extrapolation Factor (20dB/decade).

For testing above 1GHz, the emission level of the EUT in peak mode was 20dB lower than average limit (that means the emission level in peak mode also complies with the limit in average mode), then testing will be stopped and peak values of EUT will be reported, otherwise, the emissions will be measured in average mode again and reported.

Appropriate preamplifiers were used for improving sensitivity and precautions were taken to avoid overloading or desensitizing the spectrum analyzer. No post – detector video filters were used in the test.

The spectrum analyzer's 6 dB bandwidth was set to 1 MHz, and the analyzer was operated in the peak detection mode, for frequencies both below and up 1 GHz. The average levels were obtained by subtracting the duty cycle correction factor from the peak readings.

The following procedures were used to convert the emission levels measured in decibels referenced to 1 microvolt (dBuV) into field intensity in micro volts pre meter (uV/m).

The actual field intensity in decibels referenced to 1 microvolt in to field intensity in micro volts per meter (dBuV/m).



The actual field intensity in referenced to 1 microvolt per meter (dBuV/m) is determined by algebraically adding the measured reading in dBuV, the antenna factor (dB), and cable loss (dB) and Subtracting the gain of preamplifier (dB) is auto calculate in spectrum analyzer.

(1) $\text{Amplitude (dBuV/m)} = \text{FI (dBuV)} + \text{AF (dBuV)} + \text{CL (dBuV)} - \text{Gain (dB)}$

FI= Reading of the field intensity.

AF= Antenna factor.

CL= Cable loss.

P.S Amplitude is auto calculate in spectrum analyzer.

(2) $\text{Actual Amplitude (dBuV/m)} = \text{Amplitude (dBuV)} - \text{Dis(dB)}$

The FCC specified emission limits were calculated according the EUT operating frequency and by following linear interpolation equations:

(a) For fundamental frequency : Transmitter Output < +30dBm

(b) For spurious frequency : Spurious emission limits = fundamental emission limit /10

Data of measurement within this frequency range without mark in the table above means the reading of emissions are attenuated more than 20dB below the permissible limits or the field strength is too small to be measured.



5.5. Test Result

Below 1GHz

Standard:	FCC Part 15C	Test Distance:	3m
Test item:	Radiated Emission	Power:	DC 3.7V
Model Number:	ZeCircle	Temp.(°C)/Hum.(%RH):	26(°C)/60%RH
Mode:	1	Date:	03/13/2015
		Test By:	Eric Ou Yang

Frequency (MHz)	Reading (dBuV)	Correct Factor (dB/m)	Result (dBuV/m)	Limit (dBuV/m)	Margin (dB)	Remark	Ant.Polar. H / V
--	--	--	--	--	--	QP	H
--	--	--	--	--	--	QP	H
--	--	--	--	--	--	QP	H
--	--	--	--	--	--	QP	V
--	--	--	--	--	--	QP	V
--	--	--	--	--	--	QP	V

Note: No emission found between lowest internal used/generated frequencies to 30MHz (9 kHz~30MHz).

Horizontal

Field strength 30M-1GHz 1F 3m chamber

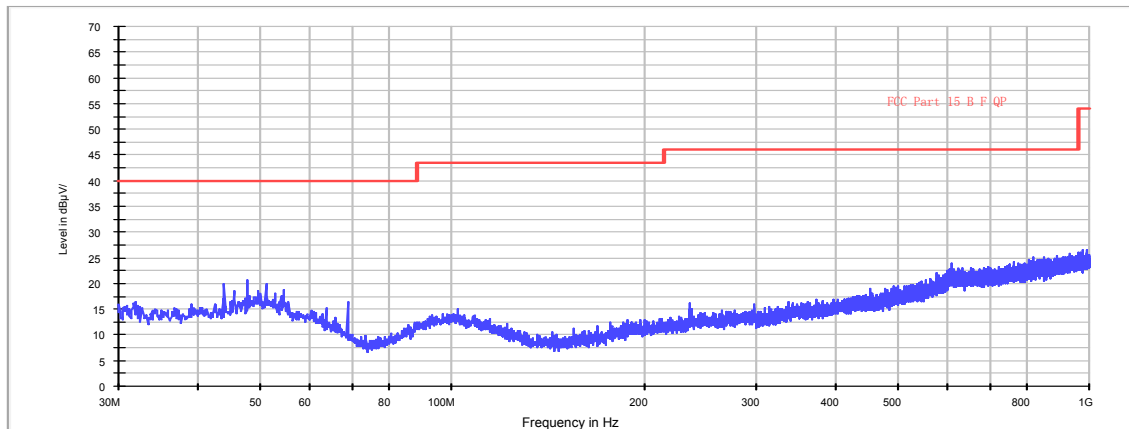

Vertical

Field strength 30M-1GHz 1F 3m chamber

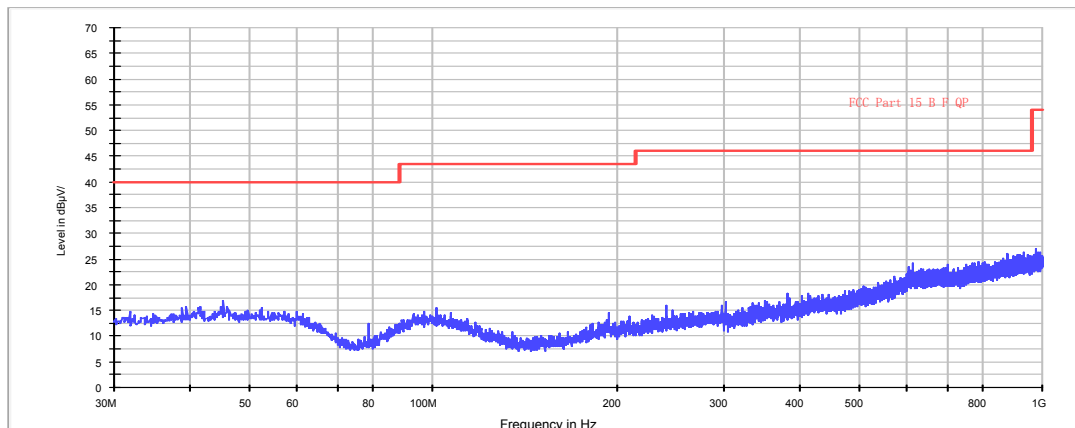



Above 1GHz

Standard:	FCC Part 15C	Test Distance:	3m
Test item:	Radiated Emission	Power:	DC 3.7V
Model Number:	ZeCircle	Temp.(°C)/Hum.(%RH):	26(°C)/60%RH
Mode:	2	Date:	03/15/2015
Frequency:	2402MHz	Test By:	Eric Ou Yang

Frequency (MHz)	Reading (dBuV)	Correct Factor (dB/m)	Result (dBuV/m)	Limit (dBuV/m)	Margin (dB)	Remark	Ant.Polar. H / V
4804.00	42.71	0.20	42.91	74.00	31.09	peak	H
4804.00	37.02	0.20	37.22	54.00	16.78	Average	H
4804.00	37.11	6.15	43.26	74.00	30.74	peak	V
4804.00	32.01	6.15	38.16	54.00	15.84	Average	V

Horizontal

FCC Electric Field Strength 1-18GHz operate on 2.4GHz

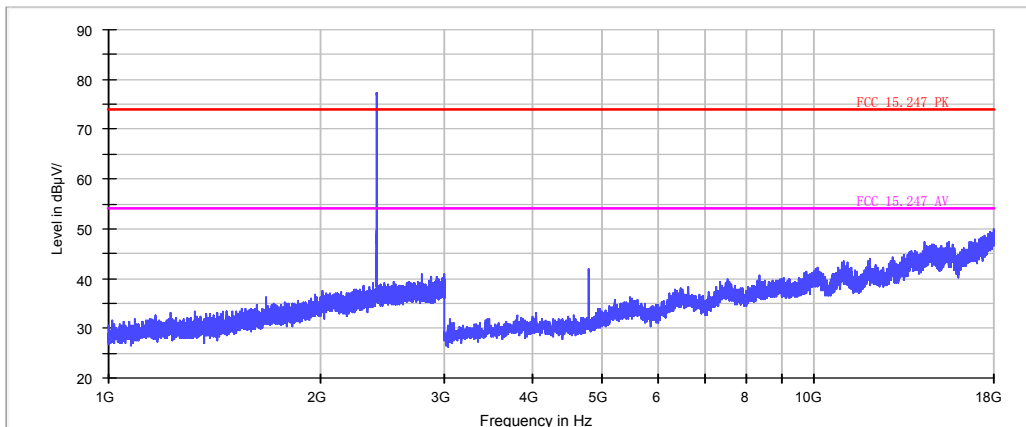

Vertical

FCC Electric Field Strength 1-18GHz operate on 2.4GHz

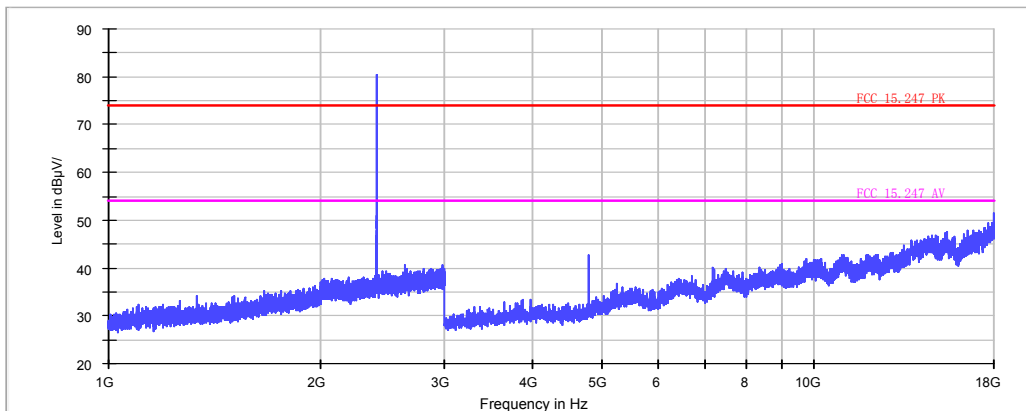



Standard:	FCC Part 15C	Test Distance:	3m
Test item:	Radiated Emission	Power:	DC 3.7V
Model Number:	ZeCircle	Temp.(°C)/Hum.(%RH):	26(°C)/60%RH
Mode:	2	Date:	03/13/2015
Frequency:	2440MHz	Test By:	Eric Ou Yang

Frequency (MHz)	Reading (dBuV)	Correct Factor (dB/m)	Result (dBuV/m)	Limit (dBuV/m)	Margin (dB)	Remark	Ant.Polar. H / V
4880	40.81	0.41	41.22	74.00	32.78	peak	H
4880	33.98	0.41	34.39	54.00	19.61	Average	H
4880	35.66	8.21	43.87	74.00	30.13	peak	V
4880	27.03	8.21	35.24	54.00	18.76	Average	V

Horizontal

FCC Electric Field Strength 1-18GHz operate on 2.4GHz

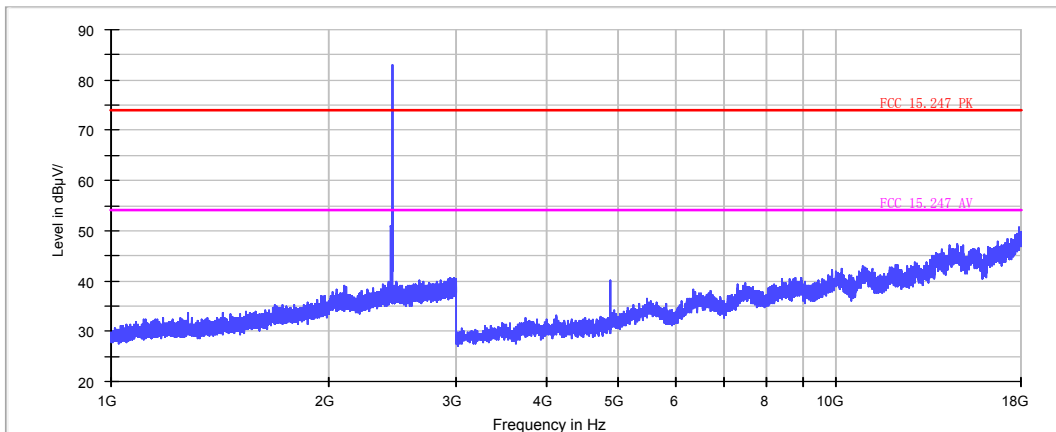

Vertical

FCC Electric Field Strength 1-18GHz operate on 2.4GHz

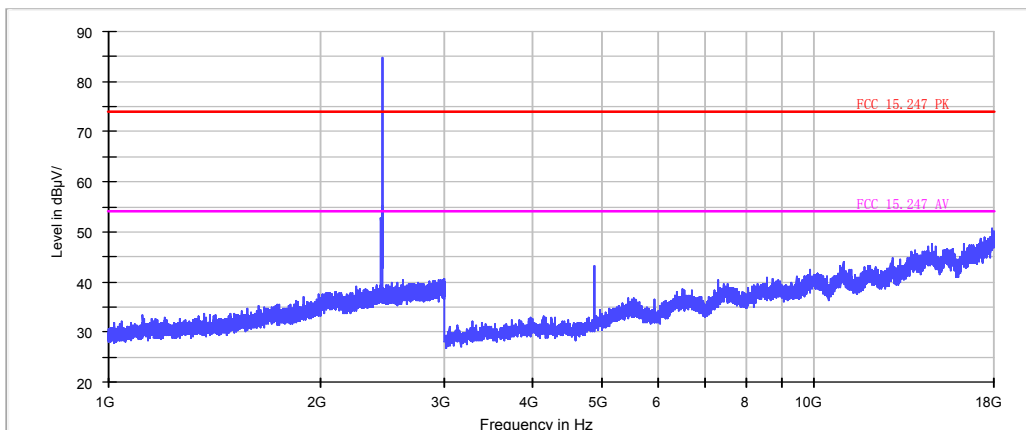



Standard:	FCC Part 15C	Test Distance:	3m
Test item:	Radiated Emission	Power:	DC 3.7V
Model Number:	ZeCircle	Temp.(°C)/Hum.(%RH):	26(°C)/60%RH
Mode:	2	Date:	03/13/2015
Frequency:	2480MHz	Test By:	Eric Ou Yang

Frequency (MHz)	Reading (dBuV)	Correct Factor (dB/m)	Result (dBuV/m)	Limit (dBuV/m)	Margin (dB)	Remark	Ant.Polar. H / V
4960	39.60	0.41	40.01	74.00	33.99	peak	H
4960	31.84	0.41	32.25	54.00	21.75	Average	H
4960	29.35	8.21	37.56	74.00	36.44	peak	V
4960	21.94	8.21	30.15	54.00	23.85	Average	V

Horizontal

FCC Electric Field Strength 1-18GHz operate on 2.4GHz

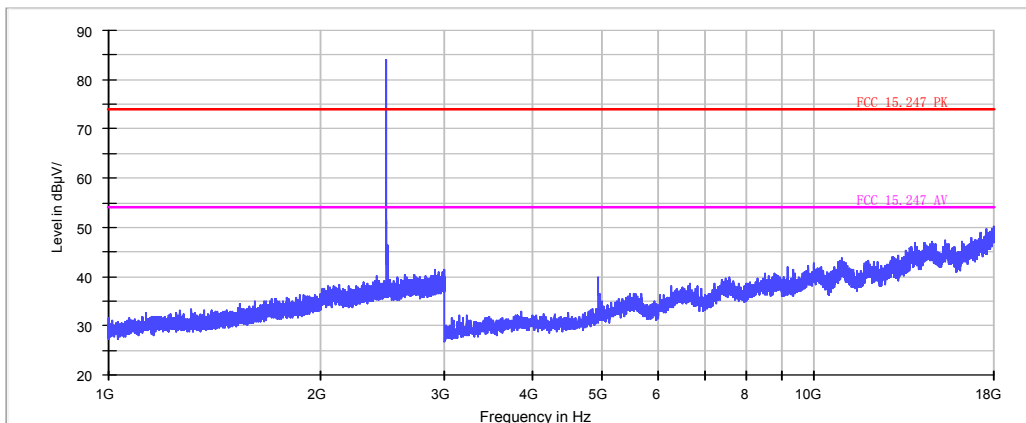

Vertical

FCC Electric Field Strength 1-18GHz operate on 2.4GHz

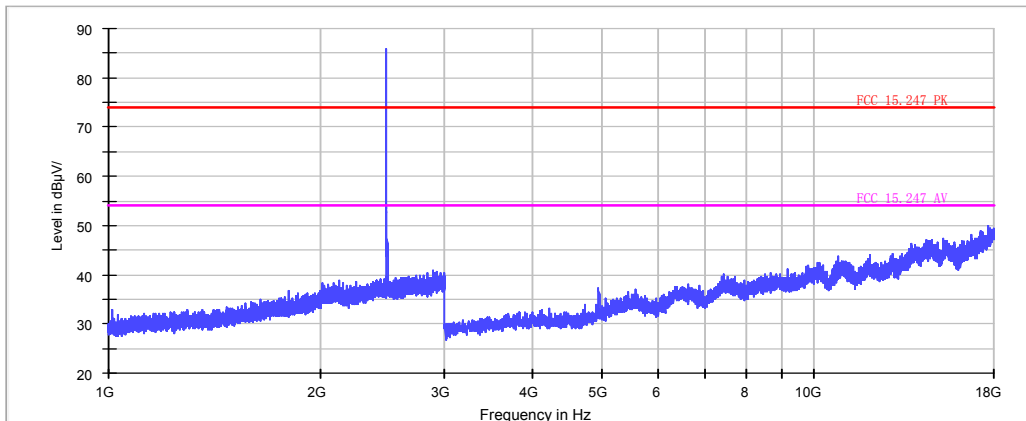

6 Maximum Conducted Output Power Measurement

6.1. Limit

For systems using digital modulation in the 2400-2483.5MHz, the limit for peak output power is 30dBm.

6.2. Test Setup

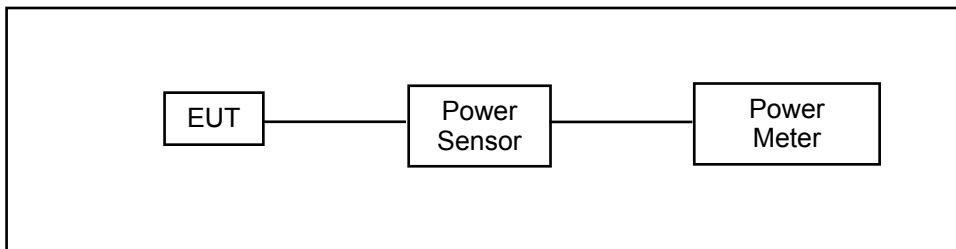

6.3. Test Instruments

Equipment	Manufacturer	Model Number	Serial Number	Cal. Date	Remark
Single Channel PK Power Sensor	Agilent	N1911A	MY45101619	12/21/2014	(1)
Wideband Power Meter	Agilent	N1921A	MY45241957	12/21/2014	(1)
Test Site	ATL	TE05	TE05	N.C.R.	-----

Remark: (1) Calibration period 1 year. (2) Calibration period 2 years. (3) Calibration period 3 years.

Note: N.C.R. = No Calibration Request.

6.4. Test Procedure

The tests below are run with the EUT's transmitter set at high power in TX mode. The EUT is needed to force selection of output power level and channel number. While testing, EUT was set to transmit continuously. Remove the Subjective device's antenna and connect the RF output port to power sensor. The maximum peak output power shall not exceed 1 watt.

Use a direct connection between the antenna port of transmitter and the power sensor, for prevent the power sensor input attenuation 40-50 dB. Set the RBW Bandwidth of the emission or use a channel power meter mode.

For antennas with gains of 6 dBi or less, maximum allowed transmitter output is 1 watt (+30 dBm). For antennas with gains greater than 6 dBi, transmitter output level must be decreased by an amount equal to (GAIN - 6)/3 dBm.

The antenna port of the EUT was connected to the input of a power sensor. Power was read directly and cable loss correction was added to the reading to obtain power at the EUT antenna terminals.



6.5. Test Result

Model Number	ZeCircle		
Test Item	Maximum Conducted Output Power		
Test Mode	Mode 2: Bluetooth v4.0 LE Link Mode		
Date of Test	03/06/2015	Test Site	TE05
Frequency (MHz)	Peak Power		Limit (dBm)
	(dBm)	(mW)	
2402	-1.08	0.780	< 30
2440	-1.06	0.783	< 30
2480	-0.08	0.982	< 30

7 6dB RF Bandwidth and 99 % Occupied Bandwidth Measurement

7.1. Limit

6dB RF Bandwidth: Systems using digital modulation techniques may operate in the 2400–2483.5 MHz bands. The minimum 6 dB band-width shall be at least 500 kHz.

99 % Occupied Bandwidth: N/A

7.2. Test Setup

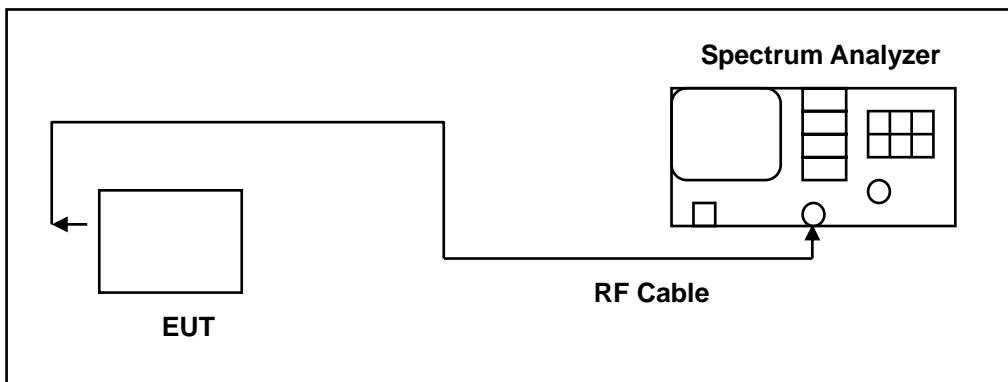

7.3. Test Instruments

Equipment	Manufacturer	Model Number	Serial Number	Cal. Date	Remark
Spectrum Analyzer	Agilent	E4445A	MY46181814	12/11/2014	(1)
Test Site	ATL	TE05	TE05	N.C.R.	-----

dRemark: (1) Calibration period 1 year. (2) Calibration period 2 years. (3) Calibration period 3 years.

Note: N.C.R. = No Calibration Request.

7.4. Test Procedure

The EUT was setup to ANSI C63.10:2013; tested to DTS test procedure of KDB558074D01 for compliance to FCC 47CFR 15.247 requirements.

6dB RF Bandwidth: The antenna port of the EUT was connected to the input of a spectrum analyzer. Analyzer RES BW was set to 100 kHz. For each RF output channel investigated, the spectrum analyzer center frequency was set to the channel carrier. A peak output reading was taken, a DISPLAY line was drawn 6 dB lower than peak level. The 6 dB bandwidth was determined from where the channel output spectrum intersected the display line.

The test was performed at 3 channels (Channel low, middle, high)

99 % Occupied Bandwidth: The transmitter shall be operated at its maximum carrier power measured under normal test conditions.

The video bandwidth shall be set to 3 times the resolution bandwidth. Video averaging is not permitted. Where practical, a sampling detector shall be used since a peak or, peak hold, may produce a wider bandwidth than actual.

The trace data points are recovered and are directly summed in linear terms. The recovered amplitude data points, beginning at the lowest frequency, are placed in a running sum until 0.5% of the total is reached and that frequency recorded. The process is repeated for the highest frequency data points. This frequency is recorded.

7.5. Test Result

Model Number	ZeCircle		
Test Item	6dB RF Bandwidth & 99 % Occupied Bandwidth		
Test Mode	Mode 2: Bluetooth v4.0 LE Link Mode		
Date of Test	19/03/2015	Test Site	TE05
Frequency (MHz)	6dB Bandwidth (kHz)	99% Occupied Bandwidth (MHz)	Limit (kHz)
2402	678.8	1.0569	≥500
2440	700.2	1.0547	≥500
2480	638.9	1.0605	≥500

7.6. Test Graphs

Mode 2: Bluetooth v4.0 LE Link Mode

<p style="text-align: center;">2402</p>	 <p>Center Freq 2.40200000 GHz</p> <p>Center Freq: 2.402000000 GHz</p> <p>Occupied Bandwidth: 1.0569 MHz</p> <p>Total Power: 8.32 dBm</p> <p>Transmit Freq Error: 8.087 kHz</p> <p>OBW Power: 99.00 %</p>
<p style="text-align: center;">2440</p>	 <p>Center Freq 2.44000000 GHz</p> <p>Center Freq: 2.440000000 GHz</p> <p>Occupied Bandwidth: 1.0547 MHz</p> <p>Total Power: 7.29 dBm</p> <p>Transmit Freq Error: 5.503 kHz</p> <p>OBW Power: 99.00 %</p>
<p style="text-align: center;">2480</p>	 <p>Center Freq 2.48000000 GHz</p> <p>Center Freq: 2.480000000 GHz</p> <p>Occupied Bandwidth: 1.0605 MHz</p> <p>Total Power: 7.91 dBm</p> <p>Transmit Freq Error: 7.044 kHz</p> <p>OBW Power: 99.00 %</p>

8 Maximum Power Density Measurement

8.1. Limit

For digitally modulated systems, the power spectral density conducted from the intentional radiator to the antenna shall not be greater than 8 dBm in any 3 kHz band during any time interval of continuous transmission.

8.2. Test Setup

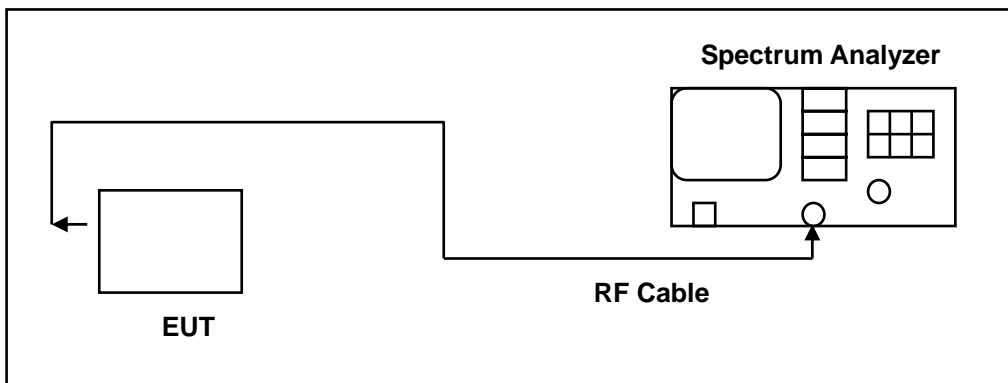

8.3. Test Instruments

Equipment	Manufacturer	Model Number	Serial Number	Cal. Date	Remark
Spectrum Analyzer	Agilent	E4445A	MY46181814	12/11/2014	(1)
Test Site	ATL	TE05	TE05	N.C.R.	----

Remark: (1) Calibration period 1 year. (2) Calibration period 2 years. (3) Calibration period 3 years.

Note: N.C.R. = No Calibration Request.

8.4. Test Procedure

The EUT was setup to ANSI C63.10:2013; tested to DTS test procedure of KDB558074D01 for compliance to FCC 47CFR 15.247 requirements.

1. Set analyzer center frequency to DTS channel center frequency.
2. Set the span to 1.5 times the DTS bandwidth.
3. Set the RBW to: $3 \text{ kHz} \leq \text{RBW} \leq 100 \text{ kHz}$.
4. Set the VBW $\geq 3 \times \text{RBW}$.
5. Detector = peak.
6. Sweep time = auto couple.
7. Trace mode = max hold.
8. Allow trace to fully stabilize.
9. Use the peak marker function to determine the maximum amplitude level within the RBW.
10. If measured value exceeds limit, reduce RBW (no less than 3 kHz) and repeat.

8.5. Test Result

Model Number	ZeCircle		
Test Item	Maximum Power Density		
Test Mode	Mode 2: Bluetooth v4.0 LE Link Mode		
Date of Test	06/30/2015	Test Site	TE05
Frequency (MHz)	Reading (dBm/3KHz)		Limit (dBm/3kHz)
2402	-13.208		< 8
2440	-14.256		< 8
2480	-14.717		< 8

8.6. Test Graphs

Mode 2: Bluetooth v4.0 LE Link Mode

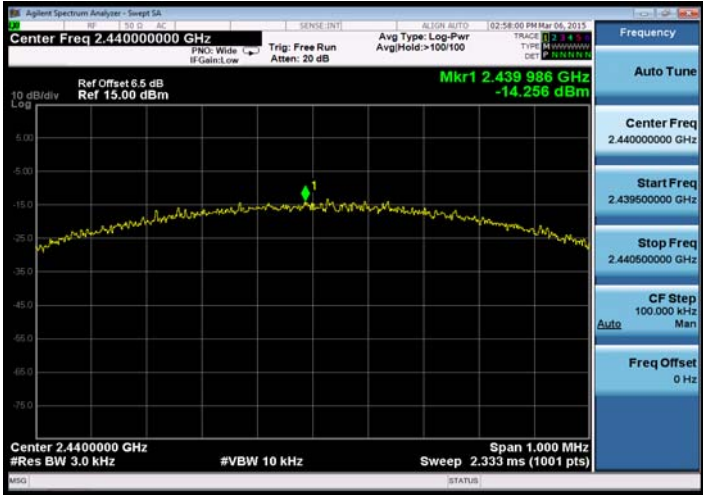
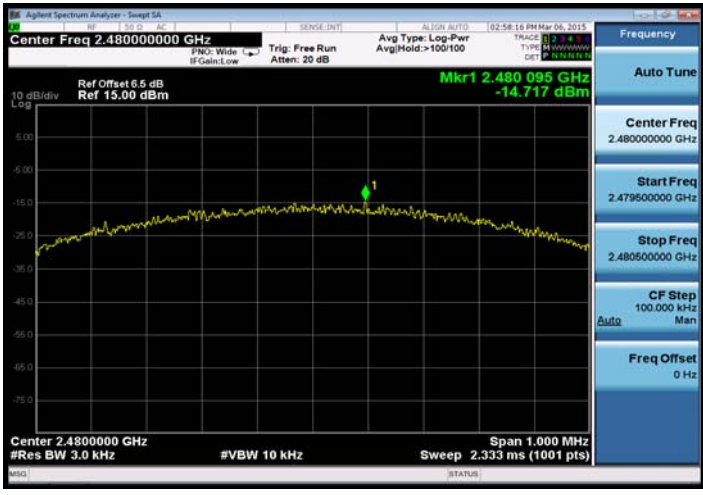
<p>2402</p>	
<p>2440</p>	
<p>2480</p>	

9 Out of Band Conducted Emissions Measurement

9.1. Limit

In any 100 kHz bandwidth outside the frequency band in which the spread spectrum or digitally modulated intentional radiator is operating, the radio frequency power that is produced by the intentional radiator shall be at least 20 dB below that in the 100 kHz bandwidth within the band that contains the highest level of the desired power

9.2. Test Setup

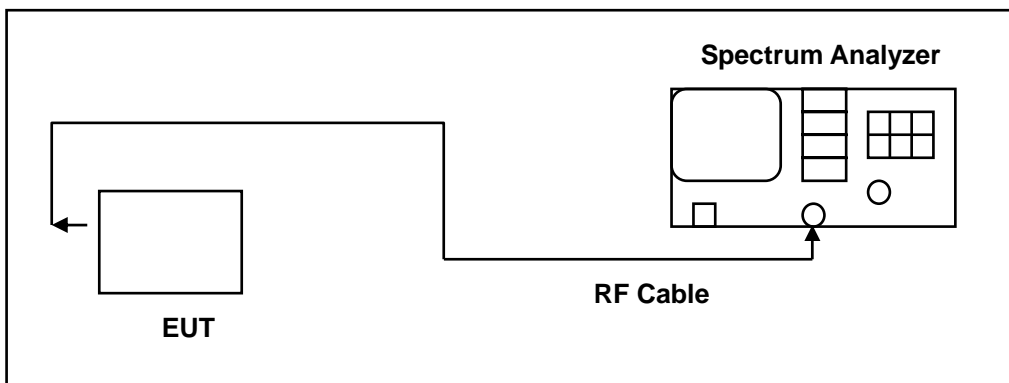

9.3. Test Instruments

Equipment	Manufacturer	Model Number	Serial Number	Cal. Date	Remark
Spectrum Analyzer	Agilent	N9020A	MY53420615	05/12/2014	(1)
Test Site	ATL	TE05	TE05	N.C.R.	-----

Remark: (1) Calibration period 1 year. (2) Calibration period 2 years. (3) Calibration period 3 years.

Note: N.C.R. = No Calibration Request.

9.4. Test Procedure

In any 100 kHz bandwidth outside the EUT pass band, the RF power produced by the modulation products of the spreading sequence, the information sequence, and the carrier frequency shall be at least 20 dB below that of the maximum in-band 100 kHz emission, antenna output of the EUT was coupled directly to spectrum analyzer; if an external attenuator and/or cable was used, these losses are compensated for with the analyzer OFFSET function.

All other types of emissions from the EUT shall meet the general limits for radiated frequencies outside the pass band.

The test was performed at 3 channels.

9.5. Test Graphs

Reference level

Mode 2: Bluetooth v4.0 LE Link Mode

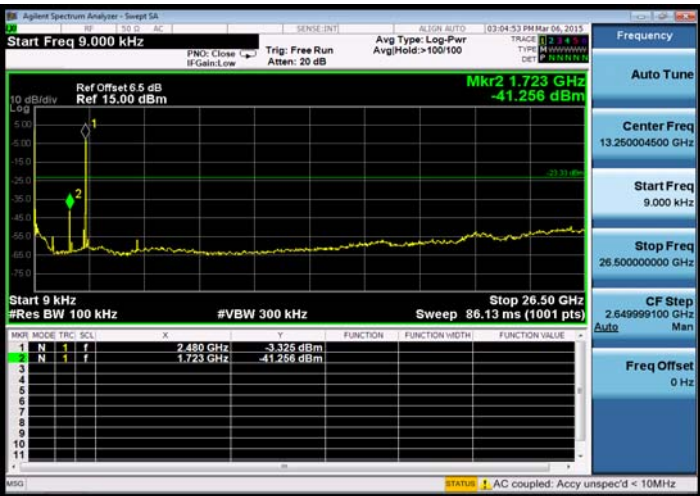
<p>2402</p>	 <table border="1" data-bbox="638 761 1212 918"> <thead> <tr> <th>MARK</th> <th>MODE</th> <th>TRIG</th> <th>SCL</th> <th>F</th> <th>X</th> <th>Y</th> <th>FUNCTION</th> <th>FUNCTION WIDTH</th> <th>FUNCTION VALUE</th> </tr> </thead> <tbody> <tr> <td>1</td> <td>N</td> <td>1</td> <td>f</td> <td></td> <td>2.412 GHz</td> <td>-2.123 dBm</td> <td></td> <td></td> <td></td> </tr> <tr> <td>2</td> <td>N</td> <td>1</td> <td>f</td> <td></td> <td>4.797 GHz</td> <td>-54.834 dBm</td> <td></td> <td></td> <td></td> </tr> </tbody> </table>	MARK	MODE	TRIG	SCL	F	X	Y	FUNCTION	FUNCTION WIDTH	FUNCTION VALUE	1	N	1	f		2.412 GHz	-2.123 dBm				2	N	1	f		4.797 GHz	-54.834 dBm			
MARK	MODE	TRIG	SCL	F	X	Y	FUNCTION	FUNCTION WIDTH	FUNCTION VALUE																						
1	N	1	f		2.412 GHz	-2.123 dBm																									
2	N	1	f		4.797 GHz	-54.834 dBm																									
<p>2440</p>	 <table border="1" data-bbox="638 1299 1212 1456"> <thead> <tr> <th>MARK</th> <th>MODE</th> <th>TRIG</th> <th>SCL</th> <th>F</th> <th>X</th> <th>Y</th> <th>FUNCTION</th> <th>FUNCTION WIDTH</th> <th>FUNCTION VALUE</th> </tr> </thead> <tbody> <tr> <td>1</td> <td>N</td> <td>1</td> <td>f</td> <td></td> <td>2.438 GHz</td> <td>-3.095 dBm</td> <td></td> <td></td> <td></td> </tr> <tr> <td>2</td> <td>N</td> <td>1</td> <td>f</td> <td></td> <td>53 MHz</td> <td>-40.884 dBm</td> <td></td> <td></td> <td></td> </tr> </tbody> </table>	MARK	MODE	TRIG	SCL	F	X	Y	FUNCTION	FUNCTION WIDTH	FUNCTION VALUE	1	N	1	f		2.438 GHz	-3.095 dBm				2	N	1	f		53 MHz	-40.884 dBm			
MARK	MODE	TRIG	SCL	F	X	Y	FUNCTION	FUNCTION WIDTH	FUNCTION VALUE																						
1	N	1	f		2.438 GHz	-3.095 dBm																									
2	N	1	f		53 MHz	-40.884 dBm																									
<p>2480</p>	 <table border="1" data-bbox="638 1814 1212 1971"> <thead> <tr> <th>MARK</th> <th>MODE</th> <th>TRIG</th> <th>SCL</th> <th>F</th> <th>X</th> <th>Y</th> <th>FUNCTION</th> <th>FUNCTION WIDTH</th> <th>FUNCTION VALUE</th> </tr> </thead> <tbody> <tr> <td>1</td> <td>N</td> <td>1</td> <td>f</td> <td></td> <td>2.480 GHz</td> <td>-3.325 dBm</td> <td></td> <td></td> <td></td> </tr> <tr> <td>2</td> <td>N</td> <td>1</td> <td>f</td> <td></td> <td>1.723 GHz</td> <td>-41.256 dBm</td> <td></td> <td></td> <td></td> </tr> </tbody> </table>	MARK	MODE	TRIG	SCL	F	X	Y	FUNCTION	FUNCTION WIDTH	FUNCTION VALUE	1	N	1	f		2.480 GHz	-3.325 dBm				2	N	1	f		1.723 GHz	-41.256 dBm			
MARK	MODE	TRIG	SCL	F	X	Y	FUNCTION	FUNCTION WIDTH	FUNCTION VALUE																						
1	N	1	f		2.480 GHz	-3.325 dBm																									
2	N	1	f		1.723 GHz	-41.256 dBm																									

10 Band Edges Measurement

10.1.Limit

In any 100 kHz bandwidth outside the intentional radiation frequency band, the radio frequency power shall be at least 20 dB below the highest level of the radiated power. In addition, radiated emissions which fall in the restricted bands must also comply with the radiated emission limits.

10.2.Test Setup

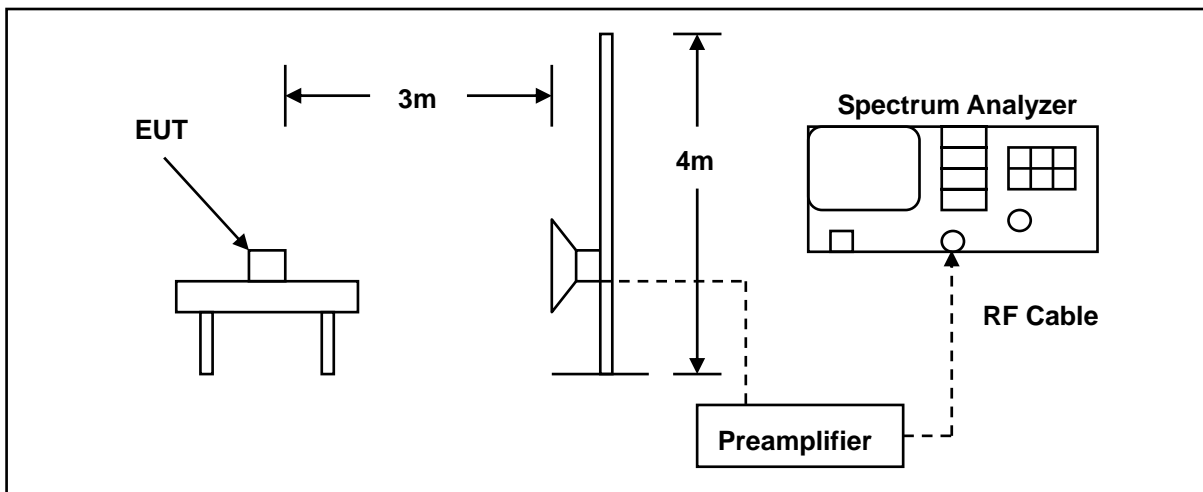

10.3.Test Instruments

3 Meter Chamber					
Equipment	Manufacturer	Model Number	Serial Number	Cal. Date	Remark
RF Pre-selector	Agilent	N9039A	MY46520256	01/10/2015	(2)
Spectrum Analyzer	Agilent	E4446A	MY46180578	01/10/2015	(1)
Pre Amplifier	Agilent	8449B	3008A02237	02/21/2014	(1)
Pre Amplifier	Agilent	8447D	2944A10961	02/21/2014	(1)
Horn Antenna (1~18GHz)	SCHWARZBECK MESS-ELEKTRONIK	BBHA9120D	9120D-550	06/10/2014	(1)
Test Site	ATL	TE01	888001	08/28/2014	(1)

Remark: (1) Calibration period 1 year. (2) Calibration period 2 years. (3) Calibration period 3 years.

Note: N.C.R. = No Calibration Request.

10.4. Test Procedure

The EUT was setup to ANSI C63.10:2013; tested to DTS test procedure of KDB558074D01 for compliance to FCC 47CFR 15.247 requirements.

The emissions on the harmonics frequencies, the limits, and the margin of compliance are presented. These tests were made when the transmitter was in full radiated power. The additional test was performed to show compliance with the requirement at the band-edge frequency 2483.5 MHz and up to 2500 MHz and at 2390.0 MHz.

The transmitter was configured with the worst case antenna and setup to transmit at the highest channel. Then the field strength was measured at 2483.5 MHz.

The transmitter was then configured with the worst case antenna and setup to transmit at the lowest channel. Then the field strength was measured at 2390.0 MHz. These tests were performed at 4 different bit rates.

For measurements the resolution bandwidth is set to 1 MHz, and then the video bandwidth is set to 1 MHz for peak measurements and 10 Hz for average measurements.

10.5. Test Result

Conducted Band Edge

Mode 2: Bluetooth v4.0 LE Link Mode																												
2402	<p>Center Freq 2.402000000 GHz</p> <p>Mkr2 2.400 00 GHz -39.714 dBm</p> <p>Center 2.40200 GHz</p> <p>#Res BW 100 kHz #VBW 300 kHz Sweep 1.000 ms (1001 pts)</p> <table border="1"> <thead> <tr> <th>MKR</th> <th>MODE</th> <th>TRIG</th> <th>SCL</th> <th>X</th> <th>Y</th> <th>FUNCTION</th> <th>FUNCTION WIDTH</th> <th>FUNCTION VALUE</th> </tr> </thead> <tbody> <tr> <td>1</td> <td>N</td> <td>1</td> <td>f</td> <td>2.402 28 GHz</td> <td>-1.555 dBm</td> <td></td> <td></td> <td></td> </tr> <tr> <td>2</td> <td>N</td> <td>1</td> <td>f</td> <td>2.400 00 GHz</td> <td>-39.714 dBm</td> <td></td> <td></td> <td></td> </tr> </tbody> </table>	MKR	MODE	TRIG	SCL	X	Y	FUNCTION	FUNCTION WIDTH	FUNCTION VALUE	1	N	1	f	2.402 28 GHz	-1.555 dBm				2	N	1	f	2.400 00 GHz	-39.714 dBm			
MKR	MODE	TRIG	SCL	X	Y	FUNCTION	FUNCTION WIDTH	FUNCTION VALUE																				
1	N	1	f	2.402 28 GHz	-1.555 dBm																							
2	N	1	f	2.400 00 GHz	-39.714 dBm																							
2480	<p>Center Freq 2.480000000 GHz</p> <p>Mkr2 2.483 50 GHz -58.107 dBm</p> <p>Center 2.48000 GHz</p> <p>#Res BW 100 kHz #VBW 300 kHz Sweep 1.000 ms (1001 pts)</p> <table border="1"> <thead> <tr> <th>MKR</th> <th>MODE</th> <th>TRIG</th> <th>SCL</th> <th>X</th> <th>Y</th> <th>FUNCTION</th> <th>FUNCTION WIDTH</th> <th>FUNCTION VALUE</th> </tr> </thead> <tbody> <tr> <td>1</td> <td>N</td> <td>1</td> <td>f</td> <td>2.480 04 GHz</td> <td>-2.788 dBm</td> <td></td> <td></td> <td></td> </tr> <tr> <td>2</td> <td>N</td> <td>1</td> <td>f</td> <td>2.483 50 GHz</td> <td>-58.107 dBm</td> <td></td> <td></td> <td></td> </tr> </tbody> </table>	MKR	MODE	TRIG	SCL	X	Y	FUNCTION	FUNCTION WIDTH	FUNCTION VALUE	1	N	1	f	2.480 04 GHz	-2.788 dBm				2	N	1	f	2.483 50 GHz	-58.107 dBm			
MKR	MODE	TRIG	SCL	X	Y	FUNCTION	FUNCTION WIDTH	FUNCTION VALUE																				
1	N	1	f	2.480 04 GHz	-2.788 dBm																							
2	N	1	f	2.483 50 GHz	-58.107 dBm																							

Mode 2: Bluetooth v4.0 LE Link Mode

2402



2480

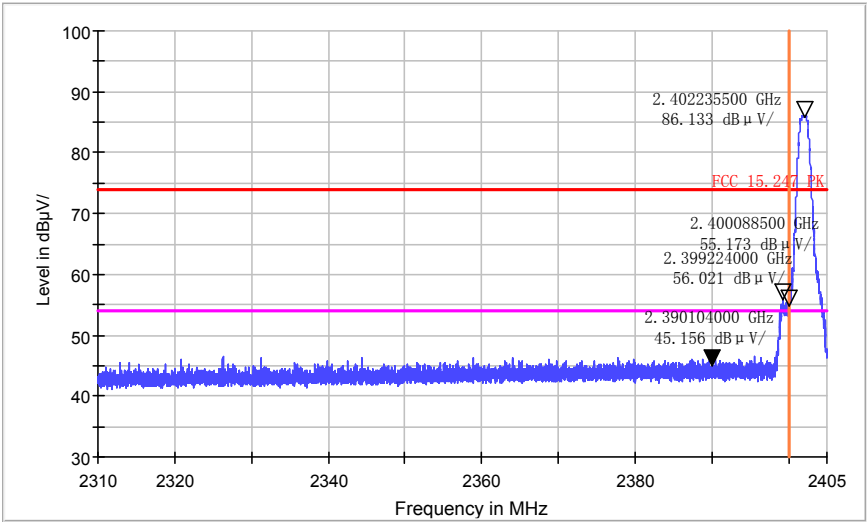
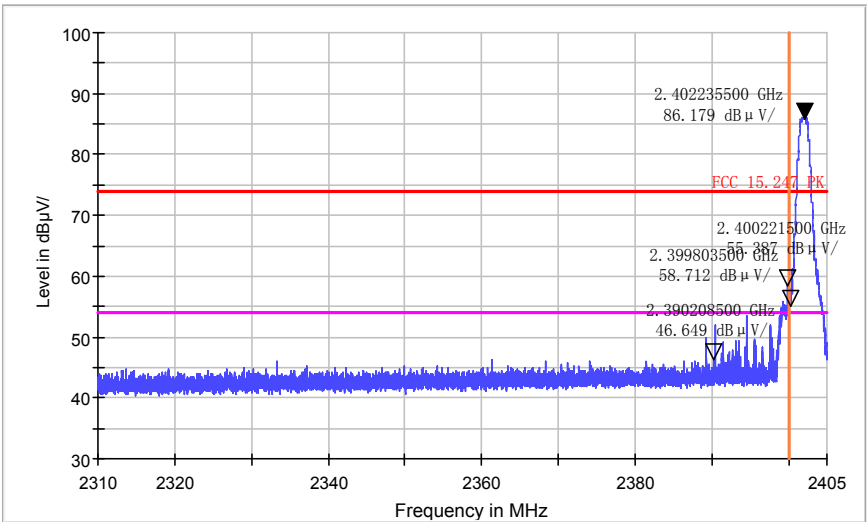

Radiated Band Edge spurious emission

Mode 2: Bluetooth v4.0 LE Link Mode																															
2402/H	<p style="text-align: center;">FCC Electric Field Strength 2.4GHz Bandedge-PK</p> 																														
2402/V	<p style="text-align: center;">FCC Electric Field Strength 2.4GHz Bandedge-PK</p> 																														
	<table border="1"> <thead> <tr> <th>Frequency (MHz)</th> <th>Result (dBuV/m)</th> <th>Limit (dBuV/m)</th> <th>Margin (dB)</th> <th>Antenna</th> <th>Remark</th> </tr> </thead> <tbody> <tr> <td>2399.2</td> <td>56.02</td> <td>74</td> <td>17.98</td> <td>H</td> <td>Peak</td> </tr> <tr> <td>2390.2</td> <td>47.16</td> <td>54</td> <td>6.84</td> <td>H</td> <td>Average</td> </tr> <tr> <td>2390.1</td> <td>58.71</td> <td>74</td> <td>15.29</td> <td>V</td> <td>Peak</td> </tr> <tr> <td>2390.1</td> <td>48.25</td> <td>54</td> <td>5.75</td> <td>V</td> <td>Average</td> </tr> </tbody> </table>	Frequency (MHz)	Result (dBuV/m)	Limit (dBuV/m)	Margin (dB)	Antenna	Remark	2399.2	56.02	74	17.98	H	Peak	2390.2	47.16	54	6.84	H	Average	2390.1	58.71	74	15.29	V	Peak	2390.1	48.25	54	5.75	V	Average
Frequency (MHz)	Result (dBuV/m)	Limit (dBuV/m)	Margin (dB)	Antenna	Remark																										
2399.2	56.02	74	17.98	H	Peak																										
2390.2	47.16	54	6.84	H	Average																										
2390.1	58.71	74	15.29	V	Peak																										
2390.1	48.25	54	5.75	V	Average																										



Mode 2: Bluetooth v4.0 LE Link Mode

2480/H

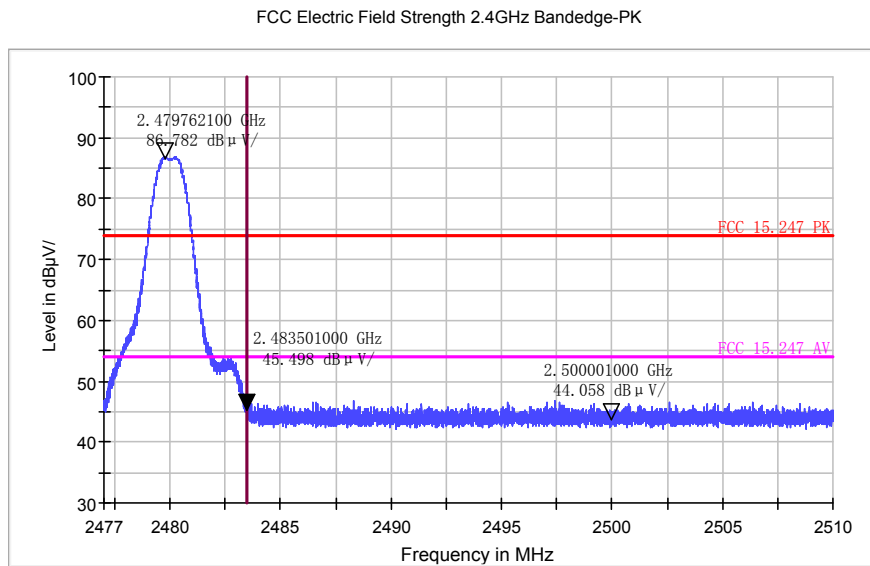

2480/V

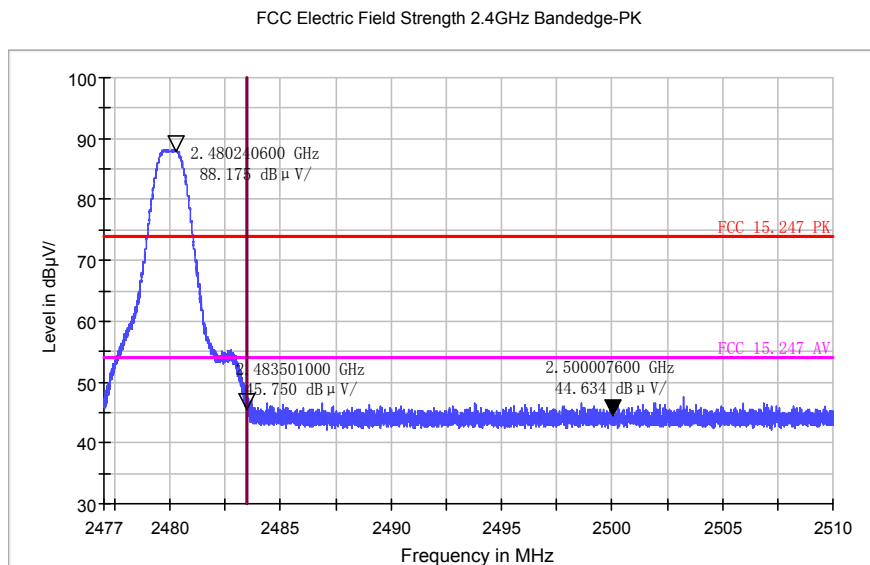

Frequency (MHz)	Result (dBuV/m)	Limit (dBuV/m)	Margin (dB)	Antenna	Remark
2483.5	45.49	74	28.51	H	Peak
2483.5	34.22	54	19.78	H	Average
2483.5	45.75	74	28.25	V	Peak
2483.5	33.34	54	20.66	V	Average



11 Antenna Measurement

11.1.Limit

For intentional device, according to 15.203, an intentional radiator shall be designed to ensure that no antenna other than that furnished by the responsible party shall be used with the device.

And According to 15.247 (b), if transmitting antennas of directional gain greater than 6 dBi are used, the power shall be reduced by the amount in dB that the directional gain of the antenna exceeds 6dBi.

11.2.Antenna Connector Construction

The antenna used in this product is Multilayer Chip Antenna. And the maximum Gain of this antenna is as below:

Bluetooth: 0.65 dBi

	Low Channel	Middle Channel	High Channel
Conducted power(dBm)	-1.08	-1.06	-0.08
Radiated power(dBm)	-0.69	-0.50	0.54
Gain(dBi)	0.43	0.59	0.65
Measurement uncertainty	±1.5dB(Cond.)/3dB(Rad)		

12 RF EXPOSURE

FCC ID: 2AA7D-ZECE1

Exposure category: General population/uncontrolled environment

EUT Type: Production Unit

Device Type: Portable Device

Refer Standard: KDB 447498 D01 General RF Exposure Guidance v05r02

FCC Part 2 §2.1093

Evaluation method

According to KDB447498 D01 General RF Exposure Guidance v05r01 Section 4.3.1 Standalone SAR test exclusion considerations: “ Unless specifically required by the published RF exposure KDB procedures, standalone 1-g head or body and 10-g extremity SAR evaluation for general population exposure conditions, by measurement or numerical simulation, is not required when the corresponding SAR Test Exclusion Threshold condition, listed below, is satisfied. These test exclusion conditions are based on source-based time-averaged maximum conducted output power of the RF channel requiring evaluation, adjusted for tune-up tolerance, and the minimum test separation distance required for the exposure conditions.²² The minimum test separation distance is determined by the smallest distance from the antenna and radiating structures or outer surface of the device, according to the host form factor, exposure conditions and platform requirements, to any part of the body or extremity of a user or bystander (see 5) of section 4.1). To qualify for SAR test exclusion, the test separation distances applied must be fully explained and justified by the operating configurations and exposure conditions of the transmitter and applicable host platform requirements, typically in the SAR measurement or SAR analysis report, according to the required published RF exposure KDB procedures. When no other RF exposure testing or reporting is required, a statement of justification and compliance must be included in the equipment approval, in lieu of the SAR report, to qualify for the SAR test exclusion. When required, the device specific conditions described in the other published RF exposure KDB procedures must be satisfied before applying these SAR test exclusion provisions; for example, handheld PTT two-way radios, handsets, laptops & tablets etc.²³ “

$$\left[\frac{(\text{max. power of channel, including tune-up tolerance, mW})}{(\text{min. test separation distance, mm})} \right] \cdot [\sqrt{f} \text{ (GHz)}] \leq 3.0$$
for 1-g SAR and ≤ 7.5 for 10-g extremity SAR, where:

- f (GHz) is the RF channel transmit frequency in GHz
- Power and distance are rounded to the nearest mW and mm before calculation
- The result is rounded to one decimal place for comparison
- 3.0 and 7.5 are referred to as the numeric thresholds in the step 2 below

The test exclusions are applicable only when the minimum test separation distance is ≤ 50 mm and for transmission frequencies between 100 MHz and 6 GHz. When the minimum test separation distance is < 5 mm, a distance of 5 mm according to 5) in section 4.1 is applied to determine SAR test exclusion.

Conducted Power Results
Bluetooth

Mode	Channel	Frequency (MHz)	Peak Conducted Output Power (dBm)
GFSK-BLE	00	2402	-1.08
	19	2440	-1.06
	39	2480	-0.08

Manufacturing tolerance
Bluetooth

GFSK-BLE (Peak)			
Channel	Channel 00	Channel 19	Channel 39
Target (dBm)	-1.08	-1.06	-0.08
Tolerance ±(dB)	1.0	1.0	1.0

Evaluation Results

Band/Mode	f (GHz)	Antenna Distance (mm)	RF output power (including tune-up tolerance)		SAR Test Exclusion Threshold	SAR Test Exclusion
			dBm	mW		
BT*	2.48	0	0.92	1.236	0.4<3.0	Yes

BT*-BT including BLE (lower power BT)

Conclusion

The measurement results comply with the FCC Limit per 47 CFR 2.1093 for the uncontrolled RF Exposure and SAR Exclusion Threshold per KDB 447498 v05r02.

.....**End of Report**.....