

ENGINEERING TEST REPORT

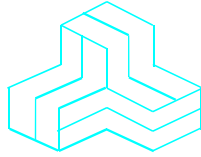

Buzz RF In Stadium Network Transmitter
Model: ST100NT
FCC ID: 2AA7C-INSTAD

Applicant:

Buzz Products PTY LTD
18 Studley Street
Abbotsford VIC 3067
Australia

In Accordance With
Federal Communications Commission (FCC)
Part 15, Subpart C, Section 15.231 Periodic Operation

UltraTech's File No.: BUZZ003_FCC15C231

This Test report is Issued under the Authority of
Tri M. Luu
Vice President of Engineering
UltraTech Group of Labs

Date: January 17, 2018

Report Prepared by: Dan Huynh

Tested by: Hung Trinh

Issued Date: January 17, 2018

Test Dates: January 8 - 10, 2018

- *The results in this Test Report apply only to the sample(s) tested, and the sample tested is randomly selected.*
- *This report must not be used by the client to claim product endorsement by any agency of the US Government.*
- *This test report shall not be reproduced, except in full, without a written approval from UltraTech*

UltraTech

3000 Bristol Circle, Oakville, Ontario, Canada L6H 6G4
Tel.: (905) 829-1570 Fax.: (905) 829-8050
Website: www.ultratech-labs.com, Email: vic@ultratech-labs.com, Email: tri@ultratech-labs.com



TABLE OF CONTENTS

EXHIBIT 1. INTRODUCTION 1

- 1.1. SCOPE 1
- 1.2. RELATED SUBMITTAL(S)/GRANT(S) 1
- 1.3. NORMATIVE REFERENCES 1

EXHIBIT 2. PERFORMANCE ASSESSMENT 2

- 2.1. CLIENT INFORMATION 2
- 2.2. EQUIPMENT UNDER TEST (EUT) INFORMATION..... 2
- 2.3. EUT'S TECHNICAL SPECIFICATIONS..... 3
- 2.4. LIST OF EUT'S PORTS 3
- 2.5. ANCILLARY EQUIPMENT 4
- 2.6. TEST SETUP BLOCK DIAGRAM..... 5

EXHIBIT 3. EUT OPERATING CONDITIONS AND CONFIGURATIONS DURING TESTS..... 6

- 3.1. CLIMATE TEST CONDITIONS 6
- 3.2. OPERATIONAL TEST CONDITIONS & ARRANGEMENT FOR TESTS 6

EXHIBIT 4. SUMMARY OF TEST RESULTS 7

- 4.1. LOCATION OF TESTS..... 7
- 4.2. APPLICABILITY & SUMMARY OF EMC EMISSION TEST RESULTS..... 7
- 4.3. MODIFICATIONS INCORPORATED IN THE EUT FOR COMPLIANCE PURPOSES 7

EXHIBIT 5. TEST DATA 8

- 5.1. PROVISIONS FOR PERIODIC TRANSMITTERS [47 CFR 15.231(A)]..... 8
- 5.2. POWER LINE CONDUCTED EMISSIONS [§15.207(A)]..... 9
- 5.3. TRANSMITTER RADIATED EMISSIONS [47 CFR §§ 15.231(B), 15.209 & 15.205]..... 12
- 5.4. 20 dB BANDWIDTH [47 CFR 15.231(C)]..... 19
- 5.5. RF EXPOSURE REQUIRMENTS [§§ 1.1310 & 2.1091] 23

EXHIBIT 6. TEST EQUIPMENT LIST 25

EXHIBIT 7. MEASUREMENT UNCERTAINTY 26

- 7.1. LINE CONDUCTED EMISSION MEASUREMENT UNCERTAINTY 26
- 7.2. RADIATED EMISSION MEASUREMENT UNCERTAINTY 26

EXHIBIT 1. INTRODUCTION

1.1. SCOPE

Reference:	FCC Part 15, Subpart C, Section 15.231
Title:	Code of Federal Regulations (CFR), Title 47, Telecommunication - Part 15
Purpose of Test:	Equipment Certification for Section 15.231 - Momentarily Operation
Test Procedures:	<ul style="list-style-type: none">▪ ANSI C63.4▪ ANSI C63.10
Environmental Classification:	Commercial, industrial or business environment

1.2. RELATED SUBMITTAL(S)/GRANT(S)

None.

1.3. NORMATIVE REFERENCES

Publication	Year	Title
FCC 47 CFR 15	2017	Code of Federal Regulations, Title 47 – Telecommunication, Part 15 - Radio Frequency Devices
ANSI C63.4	2014	American National Standard for Methods of Measurement of Radio-Noise Emissions from Low-Voltage Electrical and Electronic Equipment in the Range of 9 KHz to 40 GHz
ANSI C63.10	2013	American National Standard of Procedures for Compliance Testing of Unlicensed Wireless Devices
CISPR 16-1-1 +A1 +A2	2010 2010 2014	Specification for radio disturbance and immunity measuring apparatus and methods – Part 1-1: Radio disturbance and immunity measuring apparatus – Measuring apparatus
CISPR 16-1-2 +A1 +A2	2003 2004 2006	Specification for radio disturbance and immunity measuring apparatus and methods. Part 1-2: Conducted disturbances
CISPR 16-1-4	2010	Specification for radio disturbance and immunity measuring apparatus and methods; Part 1-4: Radio disturbance and immunity measuring apparatus - Antennas and test sites for radiated disturbance measurements

EXHIBIT 2. PERFORMANCE ASSESSMENT

2.1. CLIENT INFORMATION

Applicant	
Name:	Buzz Products PTY LTD
Address:	18 Studley Street Abbotsford VIC 3067 Australia
Contact Person:	Nick Howard Phone #: +61 3 8412 9042 Fax #: +61 3 8412 9001 Email Address: Nick.Howard@buzzproducts.com

Manufacturer	
Name:	Buzz Products PTY LTD
Address:	18 Studley Street Abbotsford VIC 3067 Australia
Contact Person:	Nick Howard Phone #: +61 3 8412 9042 Fax #: +61 3 8412 9001 Email Address: Nick.Howard@buzzproducts.com

2.2. EQUIPMENT UNDER TEST (EUT) INFORMATION

The following information (with the exception of the Date of Receipt) has been supplied by the applicant.

Brand Name:	Buzz Products PTY LTD
Product Name:	Buzz RF In Stadium Network Transmitter
Model Name or Number:	ST100NT
Serial Number:	Test sample
Type of Equipment:	Part 15 Security/Remote Control Transmitter
Input Power Supply Type:	7.2V NiMH Battery Pack / 12VDC External AC/DC wall adapter
Primary User Functions of EUT:	Activation of remote receive-only beverage cup.

2.3. EUT'S TECHNICAL SPECIFICATIONS

Transmitter	
Equipment Type:	Mobile
Intended Operating Environment:	Commercial, light industry & heavy industry
Power Supply Requirement:	1x 7.2V NiMH battery pack. Internally mounted. Accessible via removable metal panel OR 12VDC external AC/DC wall adapter
RF Output Power Rating:	80.68 dBμV/m at 3m distance
Operating Frequency Range:	430.87 – 436.87 MHz
Duty Cycle:	9.68 %
20 dB Bandwidth:	63.78 kHz
Modulation Type:	GFSK
Oscillator Frequencies:	26.000 MHz reference TCXO
Antenna Connector Type:	RP-SMA
Antenna Description:	Manufacturer: Linx Technologies Type: ¼-wave whip Model: ANT-433-PW-QW Frequency Range: 400 - 470 MHz Gain: 3.3 dBi peak

2.4. LIST OF EUT'S PORTS

Port Number	EUT's Port Description	Number of Identical Ports	Connector Type	Cable Type (Shielded/Non-shielded)
1	902-928 50-ohm antenna for co-located transceiver FCC ID MCQ-XBPSX	1	RP-SMA	Shielded
2	*USB	1	Mini USB-B jack	Shielded
3	433 MHz 50-ohm antenna	1	RP-SMA	Shielded
4	External 12VDC Power Input	1	Circular locking 2-pin	Shielded
5	*JTAG	1	2x7 header	Unshielded

* Factory configuration only

2.5. ANCILLARY EQUIPMENT

The EUT was tested while connected to the following representative configuration of ancillary equipment necessary to exercise the ports during tests:

Ancillary Equipment # 1	
Description:	AC Adapter
Brand name:	GlobTek Inc
Model Name or Number:	GT-46180-1812
Serial Number:	N/A
Connected to EUT's Port:	External 12VDC Power Input

Ancillary Equipment # 2	
Description:	Companion Device
Brand name:	Buzz Products PTY LTD
Model Name or Number:	ST100NT-P
Serial Number:	N/A
Connected to EUT's Port:	902-928 50-ohm antenna

Ancillary Equipment # 3	
Description:	Laptop
Brand name:	Dell
Model Name or Number:	Inspiron15
Serial Number:	N/A
Connected to EUT's Port:	Companion Device

2.6. TEST SETUP BLOCK DIAGRAM

Power Line Conducted Emission Test Setup

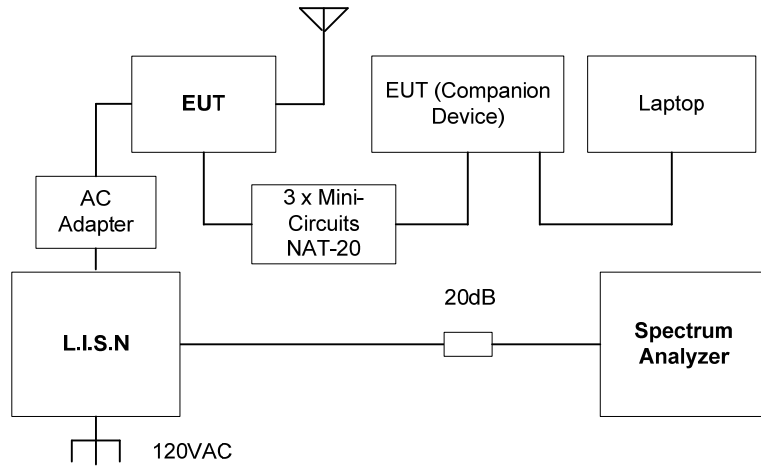

Radiated Emission Test Setup

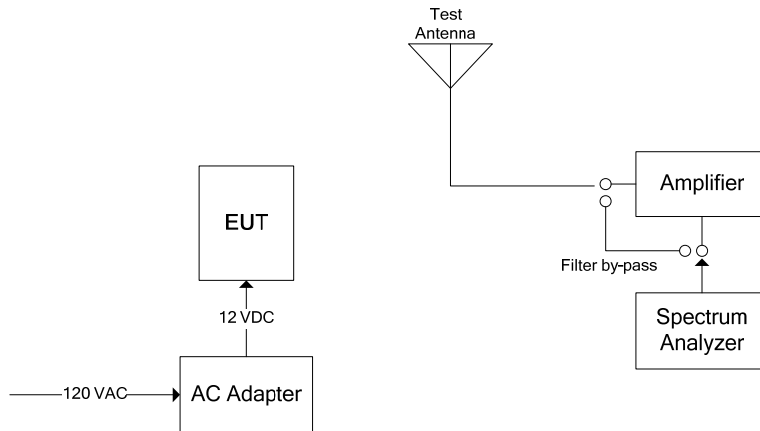

EXHIBIT 3. EUT OPERATING CONDITIONS AND CONFIGURATIONS DURING TESTS

3.1. CLIMATE TEST CONDITIONS

The climate conditions of the test environment are as follows:

Temperature:	21°C
Humidity:	51%
Pressure:	102 kPa
Power input source:	12 VDC via AC Adapter

3.2. OPERATIONAL TEST CONDITIONS & ARRANGEMENT FOR TESTS

Operating Modes:	The EUT was configured for continuous transmission for the duration of testing.
Special Test Software:	N/A
Special Hardware Used:	N/A
Transmitter Test Antenna:	The EUT was tested with the antenna fitted in a manner typical of normal intended use as non-integral antenna equipment.

Transmitter Test Signals	
Frequency Band(s):	430.87 – 436.87 MHz
Test Frequency(ies):	430.87 MHz and 436.87 MHz
RF Power Output:	80.68 dBµV/m at 3m distance
Normal Test Modulation:	GFSK
Modulating Signal Source:	Internal

EXHIBIT 4. SUMMARY OF TEST RESULTS

4.1. LOCATION OF TESTS

All of the measurements described in this report were performed at Ultratech Group of Labs located in the city of Oakville, Province of Ontario, Canada.

- AC Power Line Conducted Emissions were performed in UltraTech's shielded room, 24'(L) by 16'(W) by 8'(H).
- Radiated Emissions were performed at the Ultratech's 3-10 TDK Semi-Anechoic Chamber situated in the Town of Oakville, province of Ontario. This test site been calibrated in accordance with ANSI C63.4, and found to be in compliance with the requirements of Sec. 2.948 of the FCC Rules. The descriptions and site measurement data of the Oakville 3-10 TDK Semi-Anechoic Chamber has been filed with ANAB File No.: AT-1945.

4.2. APPLICABILITY & SUMMARY OF EMC EMISSION TEST RESULTS

FCC Section(s)	Test Requirements	Compliance (Yes/No)
15.203	Antenna Requirement	Yes*
15.207(a)	AC Powerline Conducted Emissions	Yes
15.231(b) 15.209	Transmitter Radiated Emissions - Fundamental, Harmonic and Spurious Emissions	Yes
15.231(c)	20 dB Bandwidth	Yes
15.231(d)	Frequency Tolerance for Devices Operating within the Frequency Band 40.66-40.70 MHz	Not applicable

* The EUT complies with the requirement; it employs a unique antenna connector.

4.3. MODIFICATIONS INCORPORATED IN THE EUT FOR COMPLIANCE PURPOSES

None.

EXHIBIT 5. TEST DATA

5.1. PROVISIONS FOR PERIODIC TRANSMITTERS [47 CFR 15.231(a)]

FCC Rules	FCC Provisions	Analysis on Compliance
15.231(a)	The intentional radiator restricted to the transmission of a control signal such as those used with alarm systems, door openers, remote switches, etc. Continuous transmissions, voice, video and the radio control of toys are not permitted. Data is permitted to be sent with a control signal.	Compliant. A control signal is transmitted which activates an LED display pattern in beverage glassware.
15.231(a)(1)	A manually operated transmitter shall employ a switch that will automatically deactivate the transmitter within not more than 5 seconds of being released.	Compliant. The transmitter automatically deactivates after 4.8 seconds of the switch being released.
15.231(a)(2)	A transmitter activated automatically shall cease transmission within 5 seconds after activation.	Not applicable as transmitter is manually activated.
15.231(a)(3)	Periodic transmissions at regular predetermined intervals are not permitted. However, polling or supervision transmissions, including data, to determine system integrity of transmitters used in security or safety applications are allowed if the total duration of transmissions does not exceed more than two seconds per hour for each transmitter. There is no limit on the number of individual transmissions, provided the total transmission time does not exceed two seconds per hour.	Compliant. Transmissions are not periodic. They occur on a random basis if/when home team goals are scored in a live professional sports match. Polling and/or supervisory transmissions are not employed.
15.231(a)(4)	Intentional radiators which are employed for radio control purposes during emergencies involving fire, security, and safety of life, when activated to signal an alarm, may operate during the pendency of the alarm condition.	Not applicable as the system is not for emergencies.
15.231(a)(5)	Transmission of set-up information for security systems may exceed the transmission duration limits in paragraphs (a)(1) and (a)(2) of this section, provided such transmissions are under the control of a professional installer and do not exceed ten seconds after a manually operated switch is released or a transmitter is activated automatically. Such set-up information may include data.	Not applicable as there is no set-up process and the product is not part of a security system.

5.2. POWER LINE CONDUCTED EMISSIONS [§15.207(a)]

5.2.1. Limit(s)

The equipment shall meet the limits of the following table:

Frequency of emission (MHz)	Conducted Limits (dBµV)	
	Quasi-peak	Average
0.15–0.5	66 to 56*	56 to 46*
0.5–5	56	46
5–30	60	50

*Decreases linearly with the logarithm of the frequency

5.2.2. Method of Measurements

ANSI C63.4.

5.2.3. Test Data

Plot 5.2.3.1. Power Line Conducted Emissions
 Line Voltage: AC 120 V; Line Tested: Hot

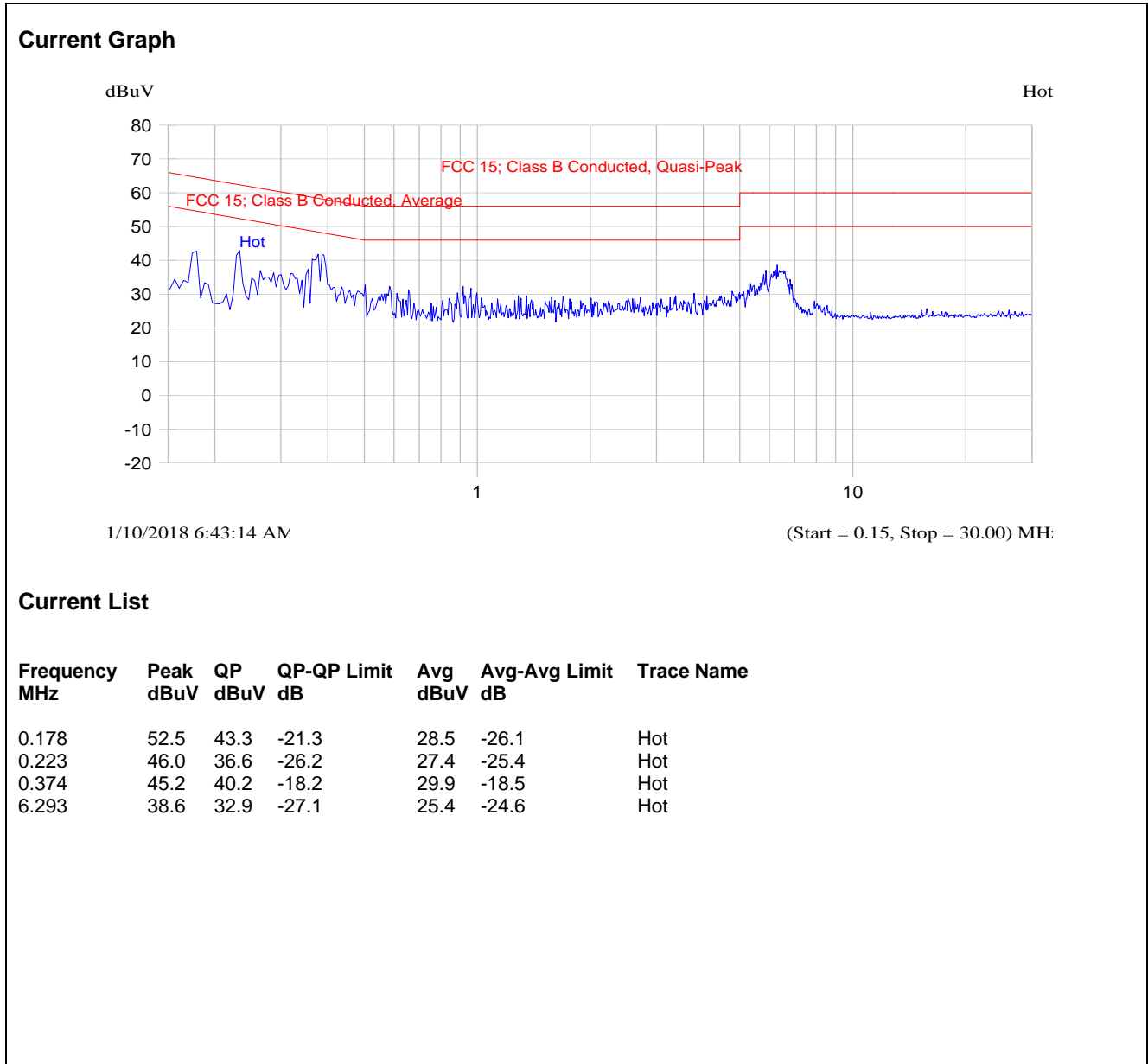

Plot 5.2.3.2. Power Line Conducted ions
 Line Voltage: AC 120 V; Line Tested: Neutral

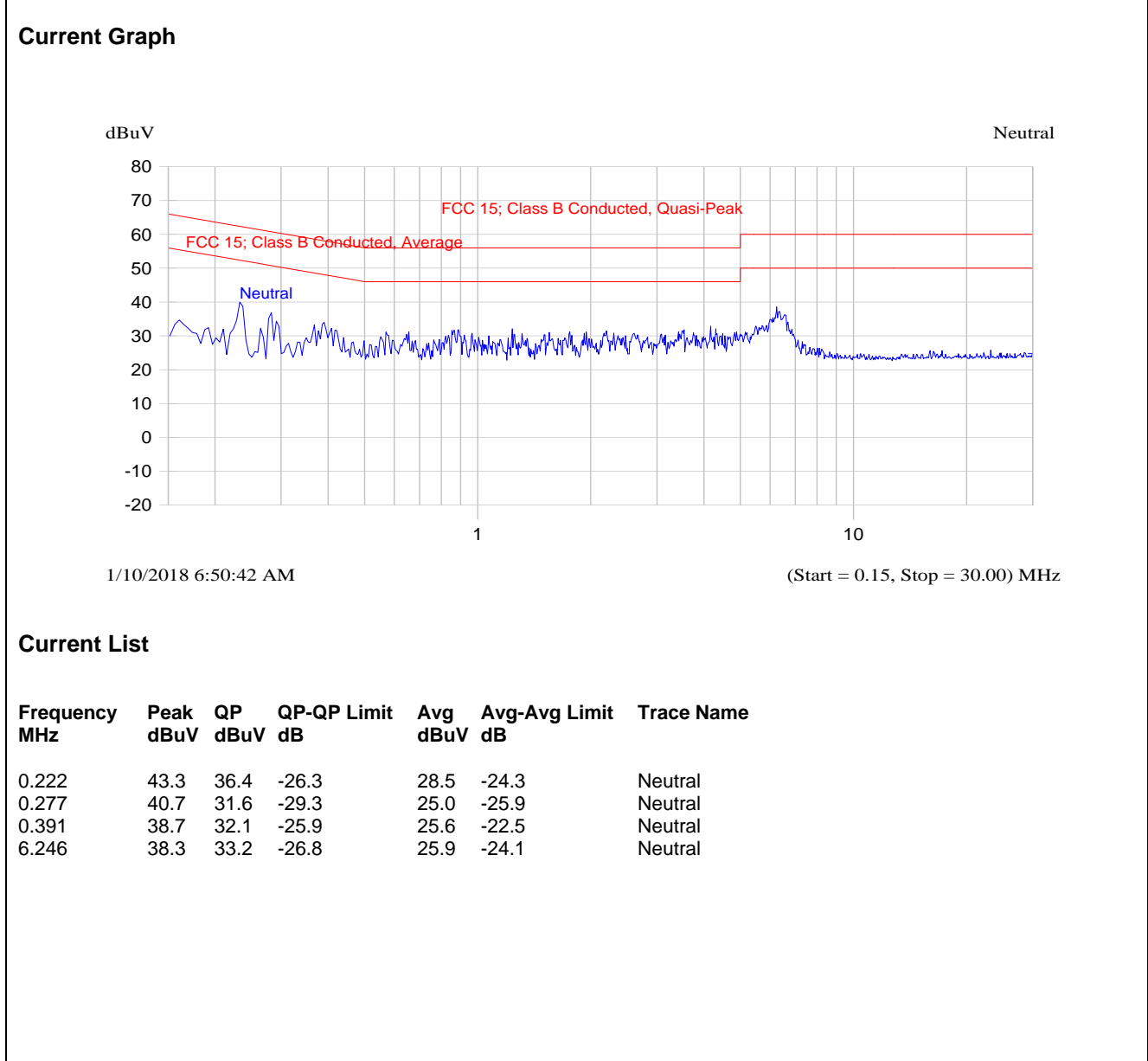

5.3. TRANSMITTER RADIATED EMISSIONS [47 CFR §§ 15.231(b), 15.209 & 15.205]

5.3.1. Limit(s)

(b) In addition to the provisions of §15.205, the field strength of emissions from intentional radiators operated under this section shall not exceed the following:

Fundamental frequency (MHz)	Field strength of fundamental (microvolts/meter)	Field strength of spurious emissions (microvolts/meter)
40.66-40.70.	2,250	225
70-130	1,250	125
130-174	1,250 to 3,750 ¹	125 to 375 ¹
174-260	3,750	375
260-470	3,750 to 12,500 ¹	375 to 1,250 ¹
Above 470	12,500	1,250

¹Linear interpolations with frequency F in MHz:

For 130-174 MHz: FS (microvolts/m) = (56.82 x F) - 6136

For 260-470 MHz: FS (microvolts/m) = (41.67 x F) - 7083.

- (1) The above field strength limits are specified at a distance of 3 meters. The tighter limits apply at the band edges.
- (2) Intentional radiators operating under the provisions of this Section shall demonstrate compliance with the limits on the field strength of emissions, as shown in the above table, based on the average value of the measured emissions. As an alternative, compliance with the limits in the above table may be based on the use of measurement instrumentation with a CISPR quasi-peak detector. The specific method of measurement employed shall be specified in the application for equipment authorization. If average emission measurements are employed, the provisions in Section 15.35 for averaging pulsed emissions and for limiting peak emissions apply. Further, compliance with the provisions of Section 15.205 shall be demonstrated using the measurement instrumentation specified in that section.

47 CFR 15.205(a) Restricted bands of operation

MHz	MHz	MHz	GHz
0.090-0.110	16.42-16.423	399.9-410	4.5-5.15
¹ 0.495-0.505	16.69475-16.69525	608-614	5.35-5.46
2.1735-2.1905	16.80425-16.80475	960-1240	7.25-7.75
4.125-4.128	25.5-25.67	1300-1427	8.025-8.5
4.17725-4.17775	37.5-38.25	1435-1626.5	9.0-9.2
4.20725-4.20775	73-74.6	1645.5-1646.5	9.3-9.5
6.215-6.218	74.8-75.2	1660-1710	10.6-12.7
6.26775-6.26825	108-121.94	1718.8-1722.2	13.25-13.4
6.31175-6.31225	123-138	2200-2300	14.47-14.5
8.291-8.294	149.9-150.05	2310-2390	15.35-16.2
8.362-8.366	156.52475-156.52525	2483.5-2500	17.7-21.4
8.37625-8.38675	156.7-156.9	2690-2900	22.01-23.12
8.41425-8.41475	162.0125-167.17	3260-3267	23.6-24.0
12.29-12.293	167.72-173.2	3332-3339	31.2-31.8
12.51975-12.52025	240-285	3345.8-3358	36.43-36.5
12.57675-12.57725	322-335.4	3600-4400	(²)
13.36-13.41.			

¹ Until February 1, 1999, this restricted band shall be 0.490-0.510 MHz.

² Above 38.6

- (3) The limits on the field strength of the spurious emissions in the above table are based on the fundamental frequency of the intentional radiator. Spurious emissions shall be attenuated to the average (or, alternatively, CISPR quasi-peak) limits shown in this table or to the general limits shown in Section 15.209, whichever limit permits a higher field strength.

47 CFR 15.209(a) General Field Strength Limits

Frequency (MHz)	Field strength (microvolts/meter)	Measurement distance (meters)
0.009–0.490	2400/F(kHz)	300
0.490–1.705	24000/F(kHz)	30
1.705–30.0	30	30
30–88	100 **	3
88–216	150 **	3
216–960	200 **	3
Above 960	500	3

** Except as provided in paragraph (g), fundamental emissions from intentional radiators operating under this section shall not be located in the frequency bands 54–72 MHz, 76– 88 MHz, 174–216 MHz or 470–806 MHz. However, operation within these frequency bands is permitted under other sections of this part, e.g., §§ 15.231 and 15.241.

5.3.2. Method of Measurements

ANSI C63.4 and/or ANSI C63.10

5.3.3. Test Data

<p>Remarks:</p> <ul style="list-style-type: none"> - The measuring receiver shall be tuned over the frequency range of 30 MHz to the 10th harmonic of the highest fundamental frequency. - All spurious emissions that are in excess of 20 dB below the specified limit shall be recorded. - For portable transmitter, EUT shall be placed in three different orthogonal positions for searching maximum field strength level. - In the restricted band per FCC 15.205: § 15.209 (a) limits applied - Outside the restricted band per FCC 15.205: § 15.231 (b) limits or § 15.209 (a) applied, whichever allows higher field strength emission. - Section 15.231(b) field strength limit of the fundamental: $20 \log [(41.67 \times f) - 7083]$, where f is frequency of fundamental in MHz. - Spurious emissions limit is 20 dB below fundamental limit. - Duty Cycle: measured maximum duty cycle is 9.68%. - The peak-average correction factor was obtained from the duty cycle calculation (see section 5.3.3.1 for details). <p style="text-align: center;">Duty cycle correction factor = $20 \times \log (T_{ON}/100 \text{ ms}) = 20 \times \log (9.68 \text{ ms}/100 \text{ ms}) = -20.28 \text{ dB}$</p>

430.87 MHz, 7 kHz Deviation							
Frequency (MHz)	Peak E-Field @ 3m (dBµV/m)	Average E-Field @ 3m (dBµV/m)	Antenna Plane (H/V)	§ 15.231 (b) Limits @ 3m (dBµV/m)	§ 15.209 (a) Limits @ 3m (dBµV/m)	Margin (dB)	Pass/Fail
Field strength of fundamental							
430.87	100.58	80.30	V	80.72	--	-0.42	Pass
430.87	99.62	79.34	H	80.72	--	-1.38	Pass
Field strength of spurious emission							
30 - 5000	*	*	V/H	60.72	*	*	Pass

* Spurious emissions are more 20 dB below the applicable limit

436.87 MHz, 7 kHz Deviation							
Frequency (MHz)	Peak E-Field @ 3m (dBµV/m)	Average E-Field @ 3m (dBµV/m)	Antenna Plane (H/V)	§ 15.231 (b) Limits @ 3m (dBµV/m)	§ 15.209 (a) Limits @ 3m (dBµV/m)	Margin (dB)	Pass/Fail
Field strength of fundamental							
436.87	100.29	80.01	V	80.92	--	-0.91	Pass
436.87	98.13	77.85	H	80.92	--	-3.07	Pass
Field strength of spurious emission							
30 - 5000	*	*	V/H	60.92	*	*	Pass

* Spurious emissions are more 20 dB below the applicable limit

430.87 MHz, 25 kHz Deviation							
Frequency (MHz)	Peak E-Field @ 3m (dBµV/m)	Average E-Field @ 3m (dBµV/m)	Antenna Plane (H/V)	§ 15.231 (b) Limits @ 3m (dBµV/m)	§ 15.209 (a) Limits @ 3m (dBµV/m)	Margin (dB)	Pass/Fail
Field strength of fundamental							
430.87	100.88	80.60	V	80.72	--	-0.12	Pass
430.87	99.59	79.31	H	80.72	--	-1.41	Pass
Field strength of spurious emission							
30 - 5000	*	*	V/H	60.72	*	*	Pass

* Spurious emissions are more 20 dB below the applicable limit

436.87 MHz, 25 kHz Deviation							
Frequency (MHz)	Peak E-Field @ 3m (dBµV/m)	Average E-Field @ 3m (dBµV/m)	Antenna Plane (H/V)	§ 15.231 (b) Limits @ 3m (dBµV/m)	§ 15.209 (a) Limits @ 3m (dBµV/m)	Margin (dB)	Pass/Fail
Field strength of fundamental							
436.87	100.96	80.68	V	80.92	--	-0.24	Pass
436.87	99.61	79.33	H	80.92	--	-1.59	Pass
Field strength of spurious emission							
30 - 5000	*	*	V/H	60.92	*	*	Pass

* Spurious emissions are more 20 dB below the applicable limit

5.3.3.1. Duty-Cycle Correction Factor

The duty cycle correction factor is the total “on time” divided by the period of the pulse train (or 100 ms).

Computation of duty-cycle correction factor

Sub-Pulse	Duration (ms)	Number of pulses	Sub-Pulse “On Time” (ms)
1	9.679487	1	9.679487
TOTAL ON TIME:			9.679487
Duty cycle correction factor: $20 \cdot \log(T_{ON}/100 \text{ ms}) = 20 \cdot \log(9.82 \text{ ms}/ 100 \text{ ms}) = -20.28 \text{ dB}$			

Plot 5.3.3.1.1. Duty Cycle (pulse train)

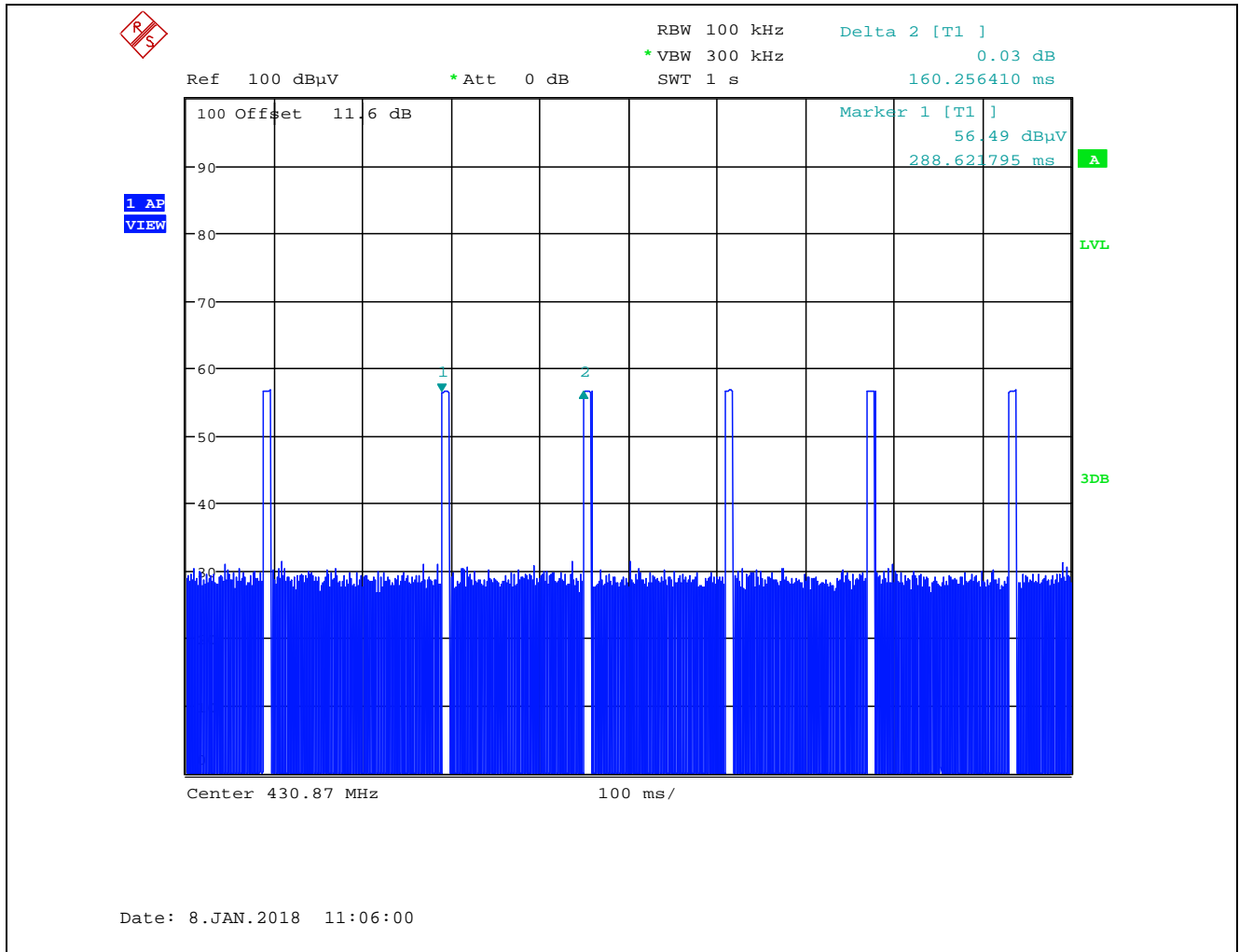

Plot 5.3.3.1.2. Duty Cycle (in 100ms)

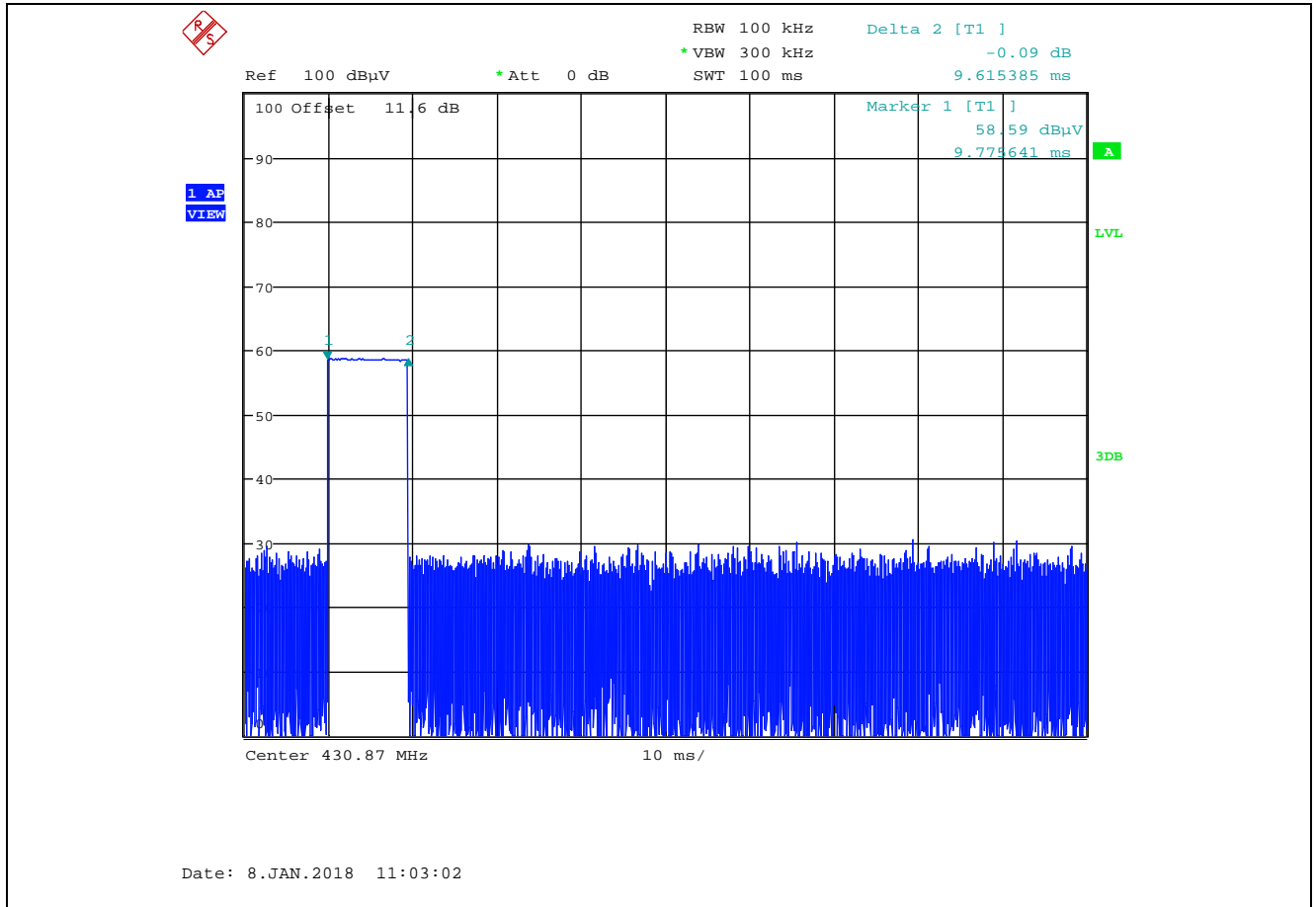

Plot 5.3.3.1.3. Duty Cycle (Pulse 1)

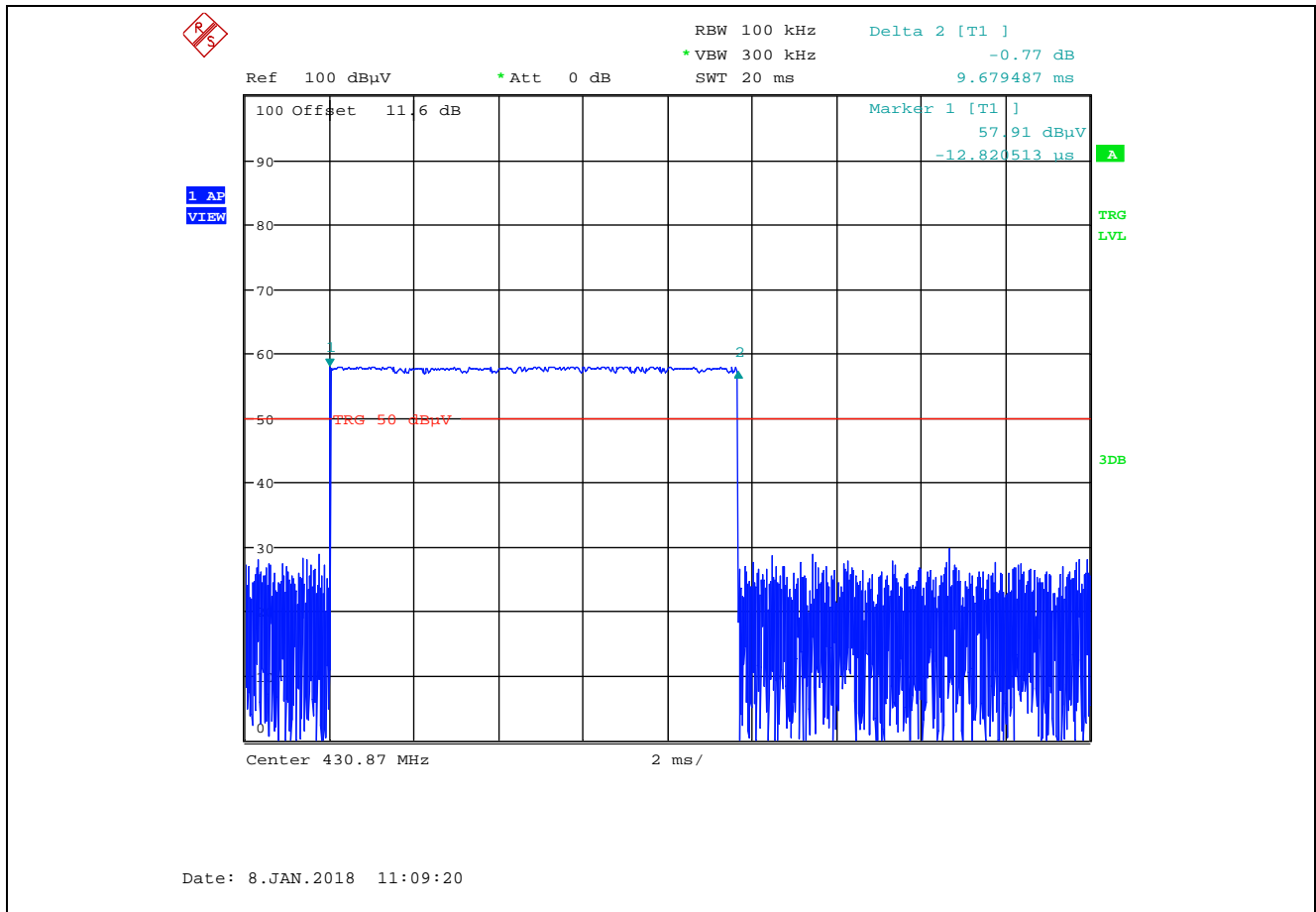

5.4. 20 dB BANDWIDTH [47 CFR 15.231(c)]

5.4.1. Limit(s)

The bandwidth of the emission shall be no wider than 0.25% of the center frequency for devices operating above 70 MHz and below 900 MHz. For devices operating above 900 MHz, the emission shall be no wider than 0.5% of the center frequency. Bandwidth is determined at the points 20 dB down from the modulated carrier.

5.4.2. Method of Measurements

ANSI C63.4.

5.4.3. Test Data

Deviation (kHz)	Channel Frequency (MHz)	20 dB Bandwidth (kHz)	Maximum Bandwidth Limit (kHz)
7	430.87	22.60	1077
	436.87	22.60	1092
25	430.87	63.78	1077
	436.87	63.46	1092

Plot 5.4.3.1. 20 dB Bandwidth, 430.87 MHz, 7 kHz Deviation

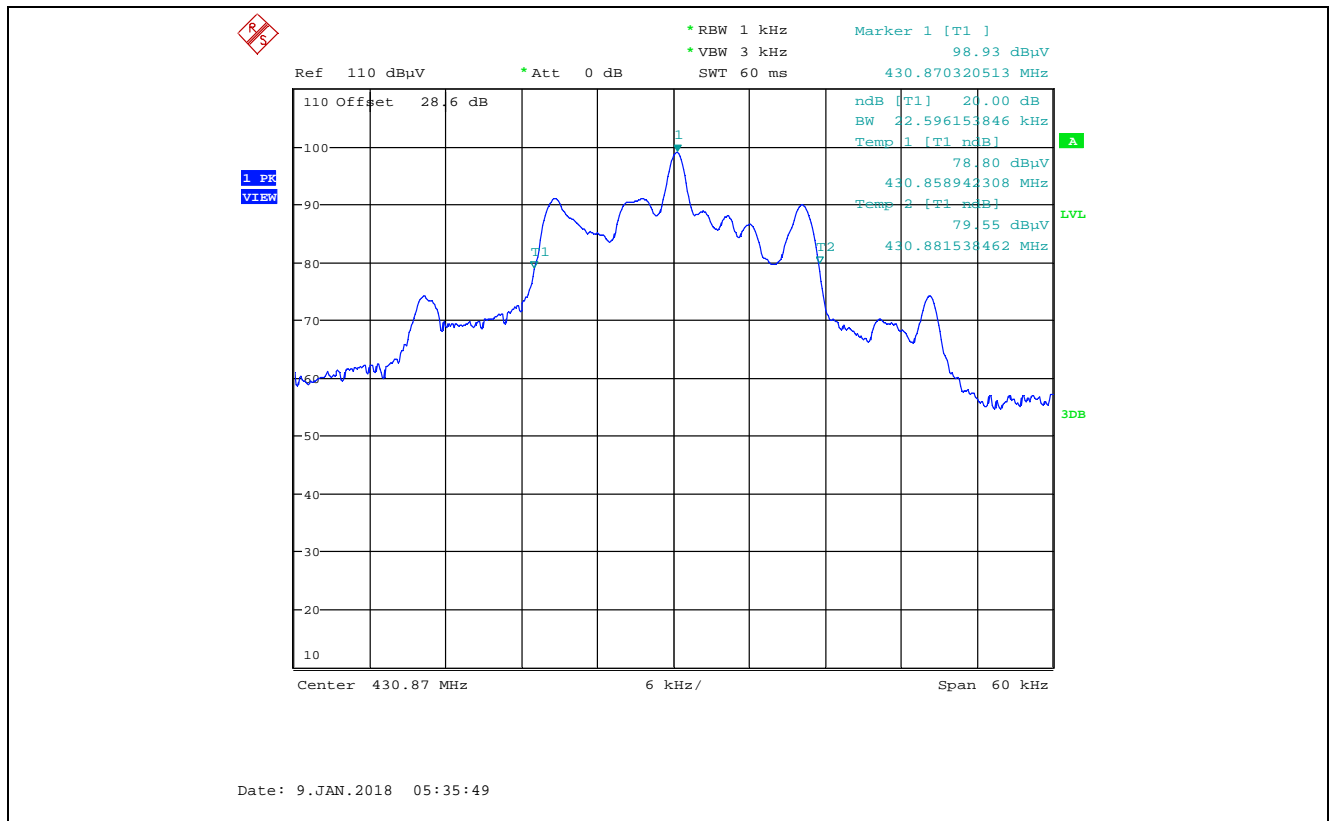

Plot 5.4.3.2. 20 dB Bandwidth, 436.87 MHz, 7 kHz Deviation

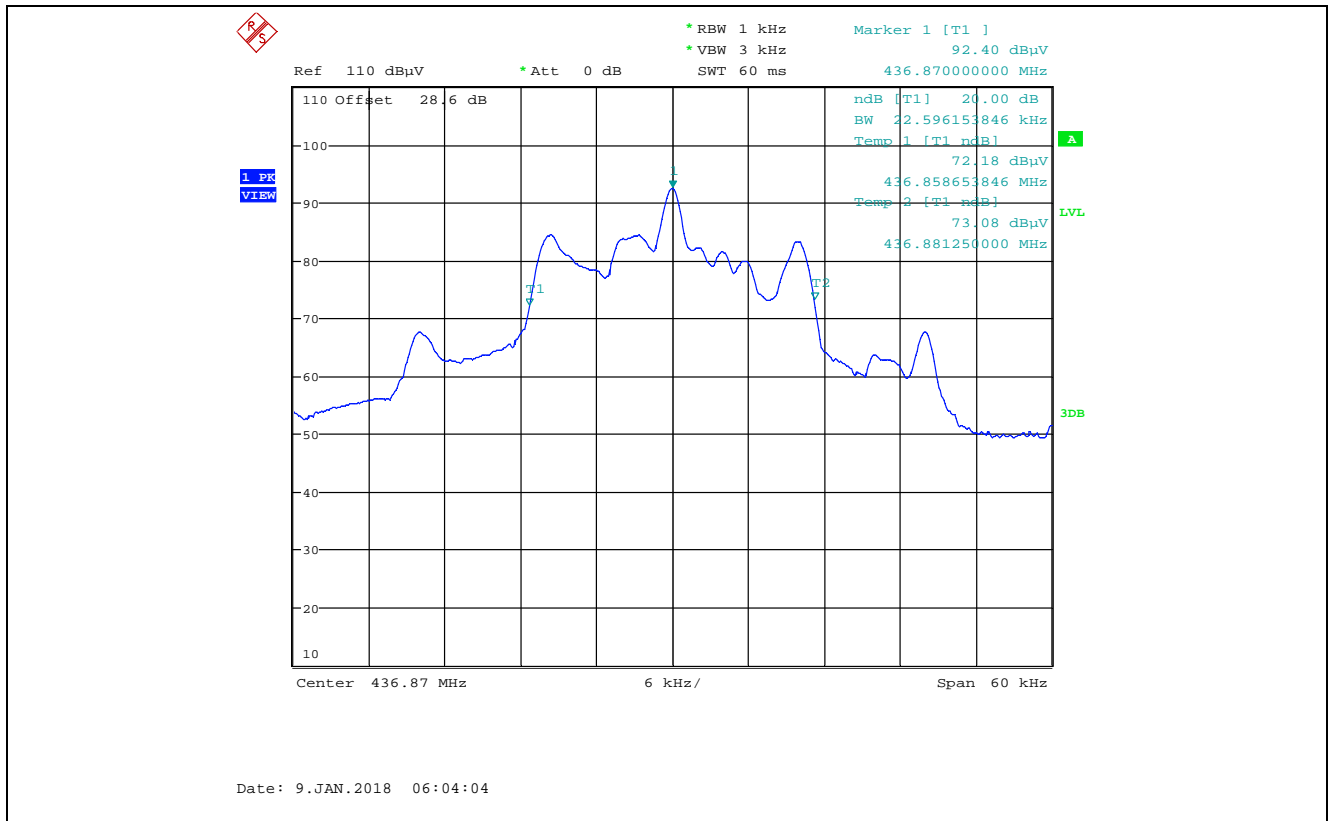

Plot 5.4.3.3. 20 dB Bandwidth, 430.87 MHz, 25 kHz Deviation

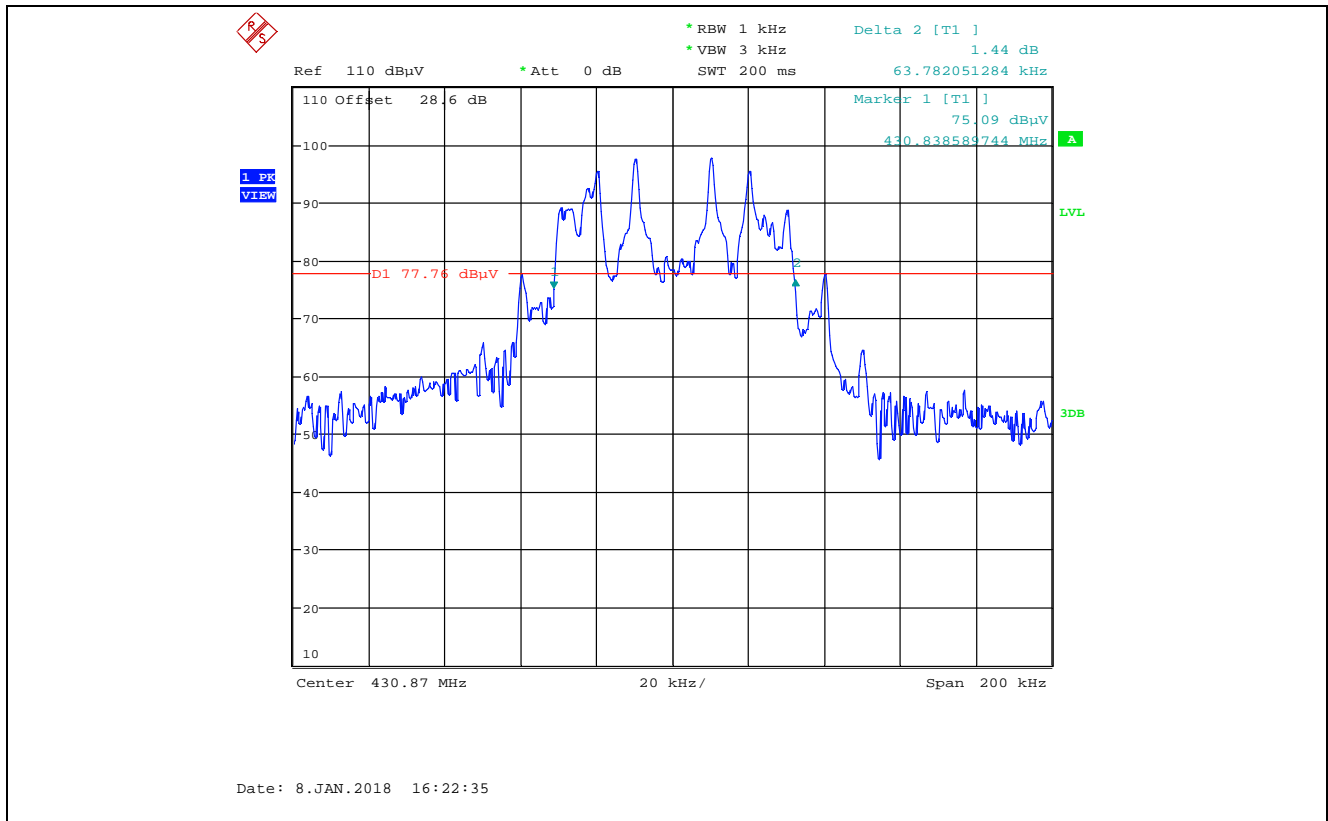

Plot 5.4.3.4. 20 dB Bandwidth, 436.87 MHz, 25 kHz Deviation

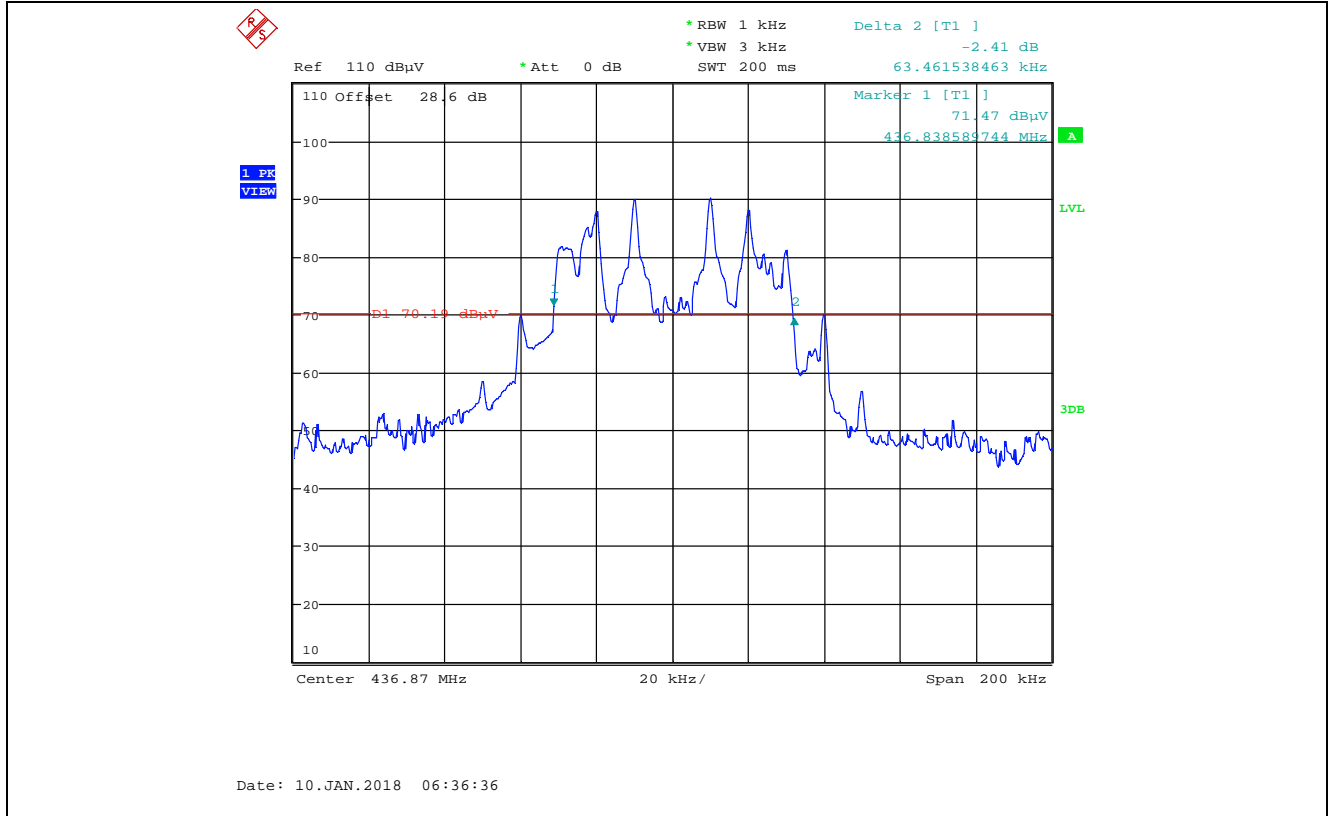

5.5. RF EXPOSURE REQUIRMENTS [§§ 1.1310 & 2.1091]

5.5.1. Limits

§ 1.1310: The criteria listed in the following table shall be used to evaluate the environmental impact of human exposure to radio-frequency (RF) radiation as specified in 1.1307(b).

Limits for Maximum Permissible Exposure (MPE)

Frequency range (MHz)	Electric field strength (V/m)	Magnetic field strength (A/m)	Power density (mW/cm ²)	Averaging time (minutes)
(A) Limits for Occupational/Controlled Exposures				
0.3-3.0	614	1.63	*(100)	6
3.0-30	1842/f	4.89/f	*(900/f ²)	6
30-300	61.4	0.163	1.0	6
300-1500			f/300	6
1500-100,000			5	6
(B) Limits for General Population/Uncontrolled Exposure				
0.3-1.34	614	1.63	*(100)	30
1.34-30	824/f	2.19/f	*(180/f ²)	30
30-300	27.5	0.073	0.2	30
300-1500			f/1500	30
1500-100,000			1.0	30

f = frequency in MHz

* = Plane-wave equivalent power density

Note 1: Occupational/controlled limits apply in situations in which persons are exposed as a consequence of their employment provided those persons are fully aware of the potential for exposure and can exercise control over their exposure. Limits for occupational/controlled exposure also apply in situations when an individual is transient through a location where occupational/controlled limits apply provided he or she is made aware of the potential for exposure.

Note 2: General population/uncontrolled exposures apply in situations in which the general public may be exposed, or in which persons that are exposed as a consequence of their employment may not be fully aware of the potential for exposure or can not exercise control over their exposure.

5.5.2. Method of Measurements

Calculation Method of Power Density/RF Safety Distance:

$$S = \frac{PG}{4\pi \cdot r^2} = \frac{EIRP}{4\pi \cdot r^2}$$

Where, P: power input to the antenna in mW
 EIRP: Equivalent (effective) isotropic radiated power.
 S: power density mW/cm²
 G: numeric gain of antenna relative to isotropic radiator
 r: distance to centre of radiation in cm

5.5.3. RF Evaluation

5.5.3.1. Co-location

Pursuant to KDB 447498 D01 General RF Exposure Guidance v06, Section 7.2:

Simultaneous transmission MPE test exclusion applies when the sum of the MPE ratios for all simultaneously transmitting antennas incorporated in a host device is ≤ 1.0, according to calculated/estimated, numerically modeled, or measured field strengths or power density.

The following table addresses the co-location of the EUT with 3.3 dBi antenna and Digi XBee-PRO SX 1W RF Module (FCC ID: MCQ-XBPSK, IC: 1846A-XBPSK)

EUT Co-located with and Digi XBee-PRO SX 1W RF Module (FCC ID: MCQ-XBPSK, IC: 1846A-XBPSK)										
Frequency Band (MHz)	Frequency (MHz)	¹ Conducted Output Power (mW)	Conducted Output Power (dBm)	Antenna Gain (dBi)	Max EUT EIRP (dBm)	Max EUT EIRP (mW)	Evaluation Distance (cm)	Power Density (mW/cm ²)	Power Density FCC Limit (mW/cm ²)	FCC Power Density MPE Ratio
430.87 – 436.87 (EUT)	430.87	1.7503	2.43	3.30	5.73	3.74	34	0.000258	0.287	0.000897
902.5 - 927.5	902.5	--	--	--	36.00	3981.07	34	0.274052	0.602	0.455235
Worst case sum of the MPE ratios for all simultaneously transmitting antennas:										0.456133
¹ Conducted output power derived from the maximum peak field strength of 100.96 dBµV/m.										

EXHIBIT 6. TEST EQUIPMENT LIST

Test Instruments	Manufacturer	Model No.	Serial No.	Frequency Range	Cal. Due Date
Semi-Anechoic Chamber	TDK	2049A-3	--	--	03 Mar 2020
Spectrum Analyzer	Hewlett Packard	HP 8593EM	3412800103	9 kHz–26.5 GHz	11 May 2018
Attenuator	Pasternack	PE7010-20	09	DC–2 GHz	13 Mar 2018
LISN Used	EMCO	3825/2R	1165	10 kHz–30 MHz	03 Nov 2018
Spectrum Analyzer	Rohde & Schwarz	FSU26	200946	20Hz–26.5 GHz	21 Jul 2018
Log Periodic	ETS-Lindgren	3148	00023845	200-2000 MHz	20 Jul 2018
Attenuator	Hewlett Packard	8493C	0465	DC–18 GHz	See Note 1
EMI Receiver	Rohde & Schwarz	ESU40	100037	20Hz–40 GHz	09 May 2018
RF Amplifier	Com-Power	PAM-0118A	551052	0.5 – 18 GHz	17 Jul 2018
Biconilog	EMCO	3142	9601-1005	26-2000 MHz	12 May 2018
Horn Antenna	EMCO	3155	5061	1 – 18 GHz	24 Apr 2018
High Pass Filter	Mini-Circuits	SHP-800	10425	Cut off 400 MHz	See Note 1
Note 1: Internal Verification/Calibration check					

EXHIBIT 7. MEASUREMENT UNCERTAINTY

The measurement uncertainties stated were calculated in accordance with the requirements of CISPR 16-4-2 @ IEC:2003 and JCGM 100:2008 (GUM 1995) – Guide to the Expression of Uncertainty in Measurement.

7.1. LINE CONDUCTED EMISSION MEASUREMENT UNCERTAINTY

	Line Conducted Emission Measurement Uncertainty (9 kHz – 30 MHz):	Measured	Limit
u_c	Combined standard uncertainty: $u_c(y) = \sqrt{\sum_{i=1}^m u_i^2(y)}$	± 1.44	± 1.8
U	Expanded uncertainty U: $U = 2u_c(y)$	± 2.89	± 3.6

7.2. RADIATED EMISSION MEASUREMENT UNCERTAINTY

	Radiated Emission Measurement Uncertainty @ 3m, Horizontal (30-1000 MHz):	Measured (dB)	Limit (dB)
u_c	Combined standard uncertainty: $u_c(y) = \sqrt{\sum_{i=1}^m u_i^2(y)}$	± 2.39	± 2.6
U	Expanded uncertainty U: $U = 2u_c(y)$	± 4.79	± 5.2

	Radiated Emission Measurement Uncertainty @ 3m, Vertical (30-1000 MHz):	Measured (dB)	Limit (dB)
u_c	Combined standard uncertainty: $u_c(y) = \sqrt{\sum_{i=1}^m u_i^2(y)}$	± 2.39	± 2.6
U	Expanded uncertainty U: $U = 2u_c(y)$	± 4.78	± 5.2

	Radiated Emission Measurement Uncertainty @ 3 m, Horizontal & Vertical (1 – 18 GHz):	Measured (dB)	Limit (dB)
u_c	Combined standard uncertainty: $u_c(y) = \sqrt{\sum_{i=1}^m u_i^2(y)}$	± 1.87	Under consideration
U	Expanded uncertainty U: $U = 2u_c(y)$	± 3.75	Under consideration