



Shenzhen Certification Technology Service Co., Ltd.
2F, Building B, East Area of Nanchang Second Industrial
Zone, Gushu 2nd Road, Bao'an District, Shenzhen
518126, P.R. China

TEST REPORT

FCC ID: 2AA7A-MTT

Applicant: ADAR Generale Telecom Services

Address : 15, Allee Jean Jaures, 31000 TOULOUSE- FRANCE

Equipment Under Test(EUT):

Name : 2G Mobile Phone

Model : M.T.T. Protection 2G

In Accordance with: FCC PART 2; FCC PART 22H; FCC PART 24E

Report No : STI130914168-1

Date of Test : September 20-October 8, 2013

Date of Issue : October 9, 2013

Test Result: **PASS**

In the configuration tested, the EUT complied with the standards specified above

Authorized Signature

A handwritten signature in black ink, appearing to read 'Mark Zhu', is written over a horizontal line.

(Mark Zhu)

General Manager

The manufacture should ensure that all the products in series production are in conformity with the product sample detailed in this report. If the product in this report is used in any configuration other than that detailed in the report, the manufacturer must ensure the new system complies with all relevant standards. Any mention of Shenzhen Certification Technology Service Co., Ltd. Or test done by Shenzhen Certification Technology Service Co., Ltd. Approvals in connection with, distribution or use of the product described in this report must be approved by Shenzhen Certification Technology Service Co., Ltd. Approvals in writing.

Contents

1. General Information..... 4

1.1. Description of Device (EUT)..... 4

1.2. Test Lab information..... 5

2. Summary of test 6

2.1. Summary of test result 6

2.2. Assistant equipment used for test 6

2.3. Test mode..... 7

2.4. Test Environment Conditions 7

2.5. Measurement Uncertainty (95% confidence levels, k=2)..... 7

2.6. Test Equipment 8

3. Conducted Output power..... 9

3.1. Block Diagram of Test Setup..... 9

3.2. Limit 9

3.3. Test Procedure..... 9

3.4. Test Result..... 9

4. Radiated Output power..... 10

4.1. Block Diagram of Test Setup..... 10

4.2. Limit 10

4.3. Test Procedure..... 10

4.4. Test Result..... 11

5. Occupied Bandwidth 12

5.1. Block Diagram of Test Setup..... 12

5.2. Limit 12

5.3. Test Procedure..... 12

5.4. Test Result..... 13

5.5. Original test data 13

6. Frequency stability 17

6.1. Block Diagram of Test Setup..... 17

6.2. Limit 17

6.3. Test Procedure..... 17

6.4. Test Result..... 18

7. Conducted spurious emissions..... 20

7.1. Block Diagram of Test Setup..... 20

7.2. Limit 20

7.3. Test Procedure..... 20

7.4. Test Result..... 20

8. Radiated Spurious emissions 27

8.1. Block Diagram of Test Setup..... 27

8.2. Limit 27

8.3. Test Procedure..... 27

8.4. Test Result..... 28

9. Block Edge Compliance 30

9.1. Block Diagram of Test Setup..... 30

9.2. Limit	30
9.3. Test Procedure.....	30
9.4. Test Result.....	31
10. Power line conducted emission	33
10.1. Block Diagram of Test Setup.....	33
10.2. Limit	33
10.3. Test Procedure.....	33
10.4. Test Result.....	34
11. Test setup photo	36
12. Photos of EUT	38

1. General Information

1.1. Description of Device (EUT)

EUT	:	2G Mobile Phone
Model No.	:	M.T.T. Protection 2G
Power supply	:	DC 5V from adapter with AC 120V/60Hz or DC 3.7V from battery
Adapter	:	Model No.:TY00-H-1105 Manufacturer: ADAR Generale Telecom Services
Radio Technology	:	GSM 850/1900, Bluetooth 2.1+EDR Note: This report only test for GSM, for other radio test see other test report.
Power class	:	GSM 850: Class 4 GSM 1900: Class 1
FCC Operation frequency	:	824.2MHz—848.8MHz and 1850.2MHz—1909.8MHz For GSM 2402-2480 for Bluetooth 2.1+EDR
Modulation	:	GFSK, $\pi/4$ DQPSK, 8- DPSK for BT GMSK for GSM
Antenna Type	:	PIFA Antenna Gain: 1dBi For GSM Dipole Antenna Gain: 1dBi for Bluetooth
Trade Name	:	M.T.T.
Applicant	:	ADAR Generale Telecom Services
Address	:	15, Allee Jean Jaures, 31000 TOULOUSE- FRANCE
Manufacturer	:	ADAR Generale Telecom Services
Address	:	15, Allee Jean Jaures, 31000 TOULOUSE- FRANCE

1.2. Test Lab information

Shenzhen Certification Technology Service Co., Ltd.
2F, Building B, East Area of Nanchang Second Industrial Zone,
Gushu 2nd Road, Bao'an District, Shenzhen 518126, P.R. China
FCC Registered No.:197647

2. Summary of test

2.1. Summary of test result

Description of Test Item	Standard	Results
Conducted Output power	FCC PART 2: 2.1046 FCC PART 22H: 22.913 (a) FCC PART 24E: 24.232 (c)	PASS
Radiated Output power(erp/eirp)	FCC PART 22H:22.913 (a) FCC PART 24E:24.232(c)	PASS
Occupied bandwidth	FCC PART 2: 2.1049 FCC PART 22H: 22.917 (b) FCC PART 24E: 24.238 (b)	PASS
Frequency stability	FCC PART 2: 2.1055 FCC PART 22H: 22.355 FCC PART 24E: 24.235	PASS
Conducted spurious emission (Antenna terminal)	FCC PART 2: 2.1051 FCC PART 22H: 22.917 FCC PART 24E: 24.238	PASS
Radiated spurious emissions	FCC PART 2: 2.1053 FCC PART 22H: 22.917 FCC PART 24E: 24.238	PASS
Block edge compliance	FCC PART 22H: 22.917 (b) FCC PART 24E: 24.238 (b)	PASS
Power Line Conducted Emission Test	FCC Part 15: 15.207 ANSI C63.4: 2003	PASS

2.2. Assistant equipment used for test

Description	:	Adapter
Manufacturer	:	ADAR Generale Telecom Services
Model No.	:	TY00-H-1105

2.3. Test mode

During all testing, EUT is in link mode with base station emulator at maximum power level in each test mode and channel as below:

Mode	Channel	Frequency(MHz)
GSM 850	128	824.2
	190	836.6
	251	848.8
PCS 1900	512	1850.2
	661	1880.0
	810	1909.8

2.4. Test Environment Conditions

Temperature range	21-25°C
Humidity range	40-75%
Pressure range	86-106kPa

2.5. Measurement Uncertainty (95% confidence levels, k=2)

Item	MU	Remark
Uncertainty for Power point Conducted Emissions Test	2.42dB	
Uncertainty for Radiation Emission test in 3m chamber (30MHz to 1GHz)	3.54dB	Polarize: V
	4.1dB	Polarize: H
Uncertainty for Radiation Emission test in 3m chamber (1GHz to 25GHz)	2.08dB	Polarize: H
	2.56dB	Polarize: V
Uncertainty for radio frequency	1×10^{-9}	
Uncertainty for conducted RF Power	0.65dB	
Uncertainty for temperature	0.2°C	
Uncertainty for humidity	1%	
Uncertainty for DC and low frequency voltages	0.06%	

2.6. Test Equipment

Equipment	Manufacture	Model No.	Serial No.	Last cal.	Cal Interval
3m Semi-Anechoic	ETS-LINDGREN	N/A	SEL0017	Nov. 16, 12	1 Year
Spectrum analyzer	Agilent	E4443A	MY46185649	Oct. 31, 12	1 Year
Receiver	R&S	ESCI	100492	Oct. 31, 12	1 Year
Receiver	R&S	ESCI	101202	Oct. 31, 12	1 Year
Bilog Antenna	Sunol	JB3	A121206	Mar.16, 13	1 Year
Horn Antenna	EMCO	3115	640201028-06	Mar.16, 13	1 Year
Power Meter	Anritsu	ML2487A	6K00001491	Oct. 31, 12	1 Year
ETS Horn Antenna	ETS	3160	SEL0076	Oct. 31, 12	1 Year
Active Loop Antenna	Beijing Daze	ZN30900A	SEL0097	Mar.16, 13	1 Year
Cable	Resenberger	N/A	No.1	Oct. 31, 12	1 Year
Cable	SCHWARZBEC K	N/A	No.2	Oct. 31, 12	1 Year
Cable	SCHWARZBEC K	N/A	No.3	Oct. 31, 12	1 Year
Pre-amplifier	R&S	AFS42-00101 800-25-S-42	SEL0081	Oct. 31, 12	1 Year
Pre-amplifier	R&S	AFS33-18002 650-30-8P-44	SEL0080	Oct. 31, 12	1 Year
Base station	Agilent	E5515C	GB44300243	Oct. 31, 12	1 Year
Temperature controller	Terchy	MHQ	120	Oct. 31, 12	1 Year
Power divider	Anritsu	K240C	020346	Oct. 31, 12	1 Year
Signal Generator	HP	83732B	VS3449051	Oct. 31, 12	1 Year
Attenuator	Agilent	8491B	MY39262165	Oct. 31, 12	1 Year

3. Conducted Output power

3.1. Block Diagram of Test Setup



3.2. Limit

Cellular Telephone 850MHz	PCS 1900MHz
38.5dBm(ERP)	33dBm(EIRP)

3.3. Test Procedure

- (1) The EUT's RF output port was connected to base station.
- (2) A call is set up by the SS according to the generic call set up procedure
- (3) Set EUT at maximum power level through base station by power level command
- (4) Measure the maximum output power of EUT at each frequency band and mode by base station.

3.4. Test Result

EUT: 2G Mobile Phone		M/N:M.T.T. Protection 2G		Power: DC 5V from adapter		
Ambient Temperature:24°C		Relative Humidity: 62%				
Test date: 2013-09-30		Test site: RF site		Tested by: Simple Guan		
Conclusion: PASS						
Mode	Channel	PK Output Power(dBm)	ERP (dBm)	EIRP (dBm)	Limit	
					ERP(dBm)	EIRP(dBm)
GSM 850	128	32.28	31.13	/	38.5	/
	190	32.34	31.19	/	38.5	/
	251	32.53	31.38	/	38.5	/
PCS 1900	512	30.09	/	31.09	/	33
	661	29.95	/	30.95	/	33
	810	30.02	/	31.02	/	33
Note: EIRP=P _k output power +Antenna Gain(1dBi); ERP=PK output power + Antenna Gain(1dBi) -2.15						

4. Radiated Output power

4.1. Block Diagram of Test Setup

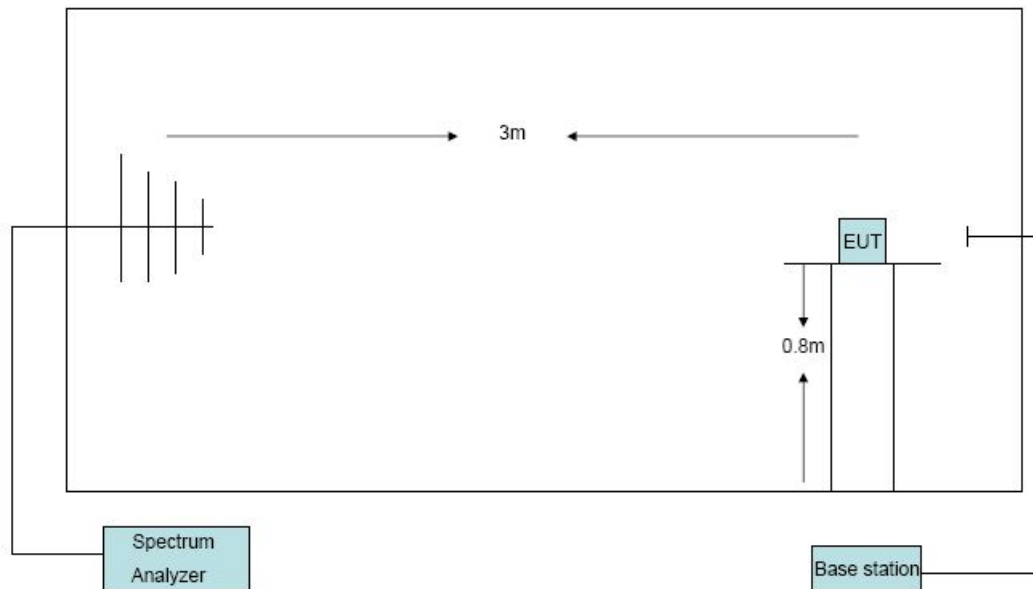

4.2. Limit

Cellular Telephone 850MHz	PCS 1900MHz
38.5dBm(ERP)	33dBm(EIRP)

4.3. Test Procedure

1. The EUT was placed on a non-conductive rotating platform with 0.8 meter height in an anechoic chamber. The radiated emission at the fundamental frequency was measured at 3 m with a test antenna and a spectrum analyzer with RBW= 3MHz, VBW= 3MHz and peak detector settings.
2. During the measurement, the EUT was enforced in maximum power and linked with a base station. The highest emission was recorded from analyzer power level (LVL) from the 360 degrees rotation of the turntable and the test antenna raised and lowered over a range from 1 to 4 meters in both horizontally and vertically polarized orientations
3. Effective Isotropic Radiated Power (EIRP) was measured by substitution method according to TIA/EIA-603-C. The EUT was replaced by dipole antenna (for frequency below 1GHz) or Horn antenna (for frequency above 1GHz) at same location with same polarization of receiver antenna and then a known power of each measure frequency from

S.G. was applied into the dipole antenna or Horn antenna through a Tx cable, and then recorded the maximum Analyzer reading through raised and lowered the test antenna. The correction factor (in dB) = S.G. - Tx Cable loss + Substitution antenna gain - Substitution antenna Loss(only for Dipole antenna) - Analyzer reading. Then the EUT's EIRP was calculated with the correction factor, $EIRP = LVL + \text{Correction factor}$ and $ERP = EIRP - 2.15$

4.4. Test Result

EUT: 2G Mobile Phone M/N:M.T.T. Protection 2G					
Power: DC 5V from adapter					
Ambient Temperature:23°C			Relative Humidity: 60%		
Test date: 2013-09-30			Test site: RF site	Tested by: Simple Guan	
Conclusion: PASS					
Mode	Channel	LVL (dBm)	Correction factor(dB)	ERP (dBm)	EIRP (dBm)
GSM 850	128	2.21	30.42	30.48	/
	190	2.08	30.21	30.14	/
	251	2.13	30.05	30.03	/
PCS 1900	512	-18.54	46.80	/	28.26
	661	-18.25	46.45	/	28.20
	810	-18.84	46.58	/	27.74
ERP=LVL + Correction factor -2.15					
EIRP=LVL+ Correction factor					

5. Occupied Bandwidth

5.1. Block Diagram of Test Setup

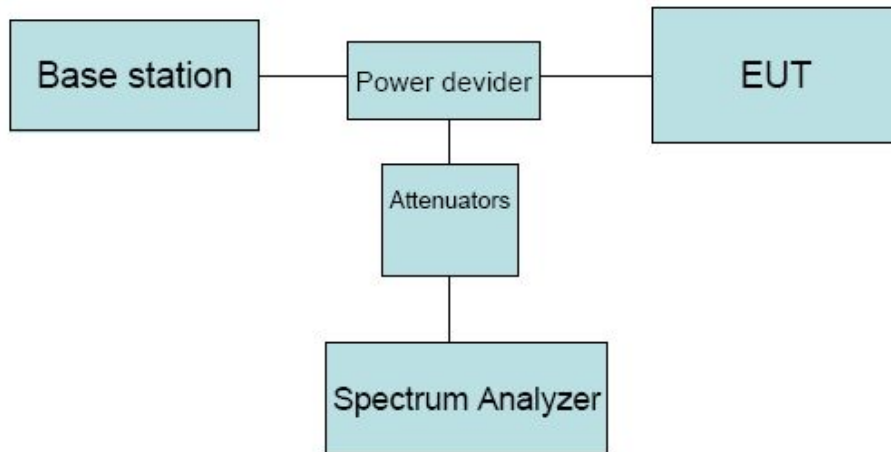

5.2. Limit

N/A

5.3. Test Procedure

1. The EUT' RF output port was connected to Spectrum Analyzer and Base Station via power divider.
2. Spectrum analyzer's occupied bandwidth measure function was used to measure 99% bandwidth and -26dBc bandwidth

5.4. Test Result

EUT: 2G Mobile Phone M/N:M.T.T. Protection 2G			
Power: DC 5V from adapter			
Ambient Temperature:23°C		Relative Humidity: 60%	
Test date: 2013-09-30		Test site: RF site	Tested by: Simple Guan
Mode	Channel	99% bandwidth (KHz)	-26dBc bandwidth (KHz)
GSM 850	128	244.84	305.639
	190	246.31	317.54
	251	245.03	311.36
PCS 1900	512	246.65	309.01
	661	246.00	315.44
	810	247.68	311.02

5.5. Original test data

GSM 850 CH128

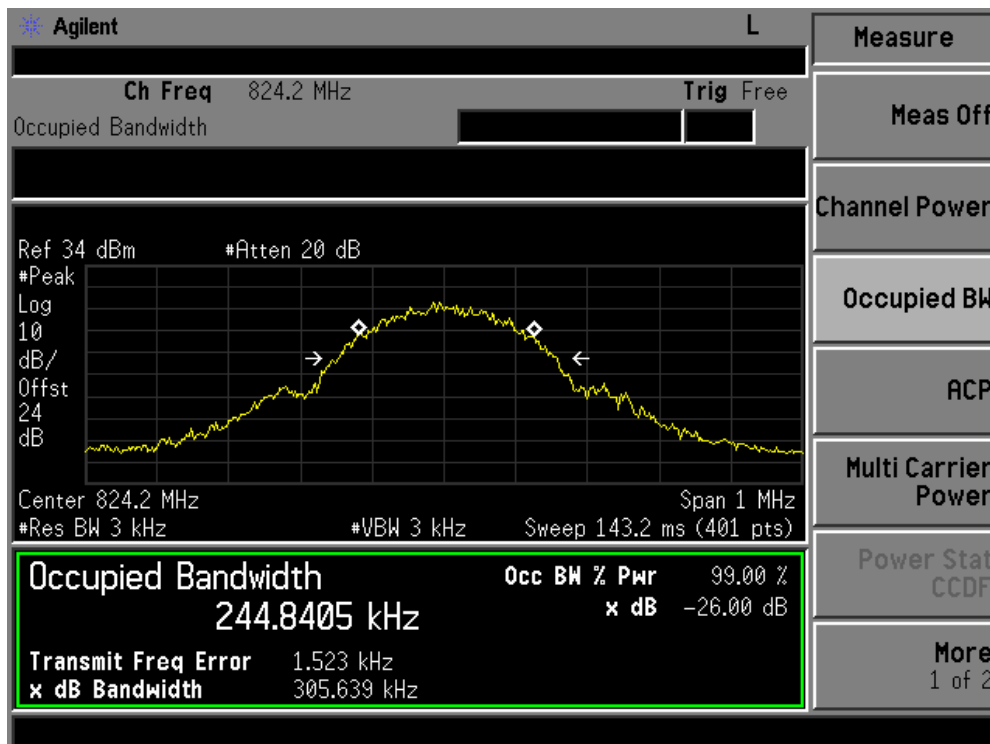

GSM 850 CH190

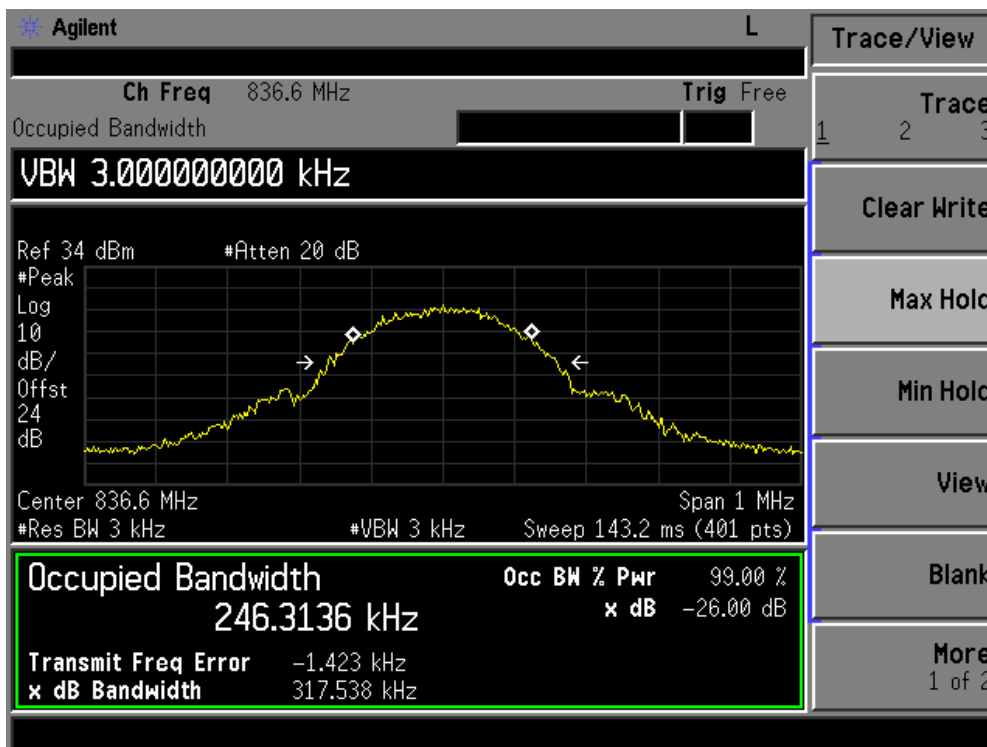

GSM 850 CH251

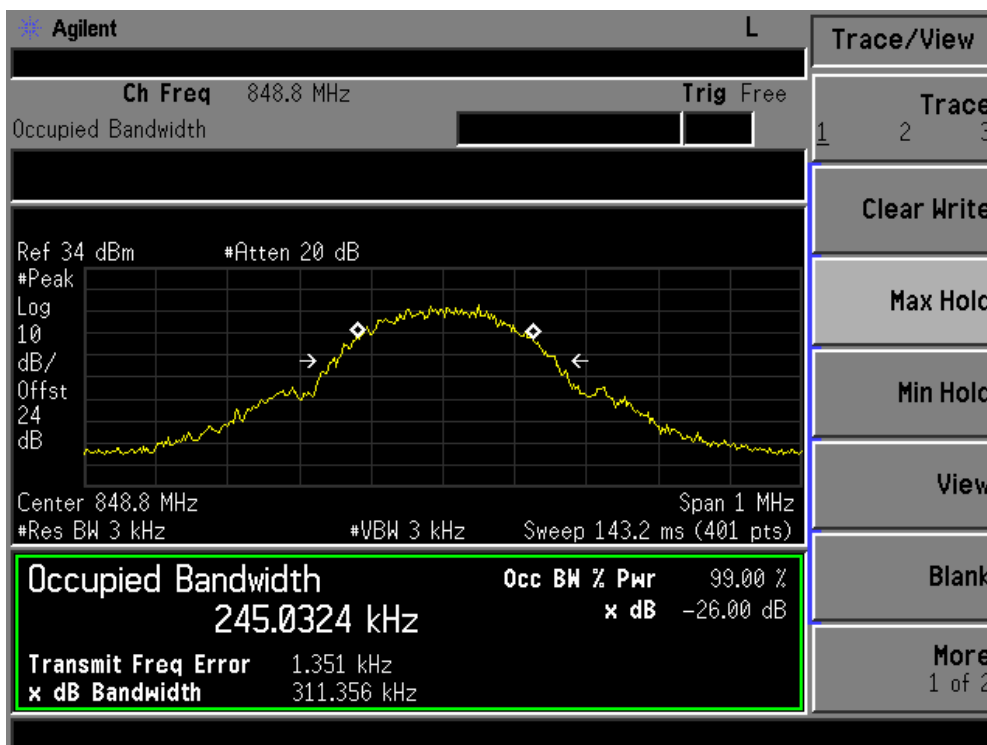

PCS 1900 CH512



PCS 1900 CH661

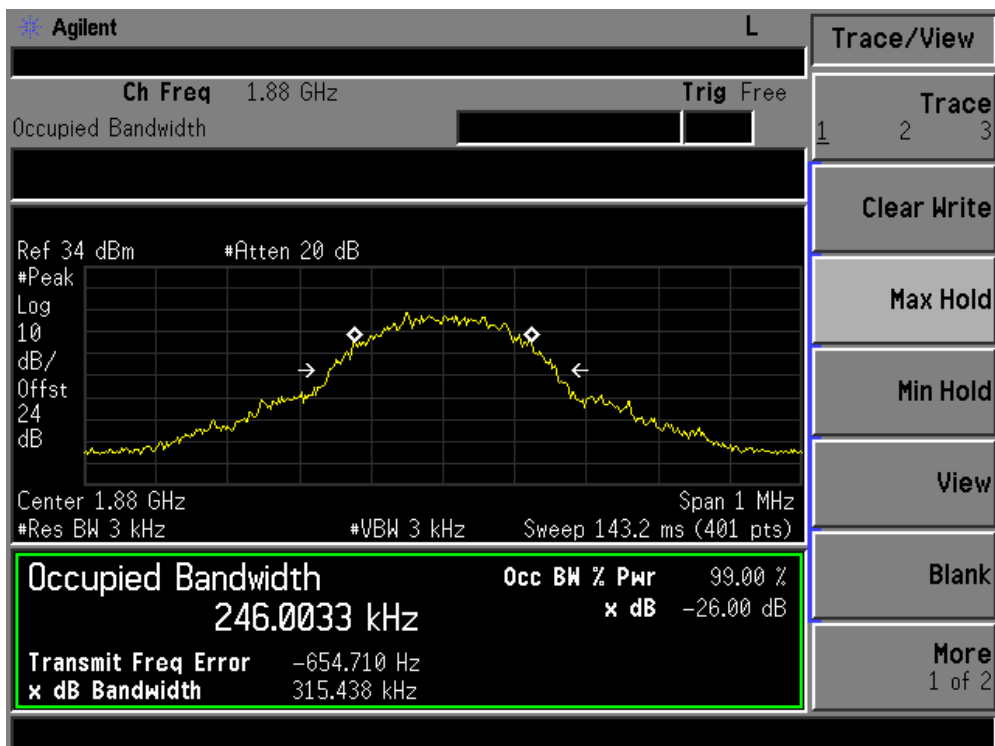

PCS 1900 CH810



6. Frequency stability

6.1. Block Diagram of Test Setup

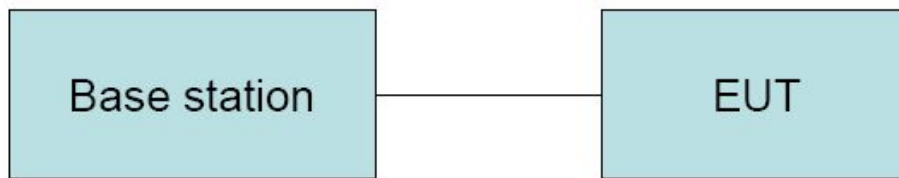

6.2. Limit

Cellular Telephone 850MHz	PCS 1900MHz
± 2.5 ppm	Must stay within the authorized frequency block

6.3. Test Procedure

Test Procedures for Temperature Variation:

1. The EUT was set up in the thermal chamber and connected with the base station.
2. With power OFF, the temperature was decreased to -10°C and the EUT was stabilized for three hours. Power was applied and the maximum change in frequency was recorded within one minute.
3. With power OFF, the temperature was raised in 10°C step up to 45°C . The EUT was stabilized at each step for at least half an hour. Power was applied and the maximum frequency change was recorded within one minute.
4. If the EUT can not be turned on at -10°C , the testing lowest temperature will be raised in 10°C step until the EUT can be turned on.

Test Procedures for Voltage Variation

1. The EUT was placed in a temperature chamber at $25\pm 5^{\circ}\text{C}$ and connected with the base station.
2. The power supply voltage to the EUT was varied from DC 5V to 3.5V
3. The variation in frequency was measured for the worst case.

6.4. Test Result

EUT: 2G Mobile Phone M/N:M.T.T. Protection 2G			
Power: DC 5V from adapter			
Ambient Temperature:23℃		Relative Humidity: 60%	
Test date: 2013-09-30		Test site: RF site	Tested by: Simple Guan
Conclusion: PASS			
Mode	Voltage (V)	Frequency error (Hz)	frequency error (ppm)
GSM 850 CH 190	5V	-15.21	-0.018
	4.5V	-15.37	-0.018
	4V	-19.84	-0.024
	3.5V	-24.15	-0.029
	3V	-13.68	-0.016
PCS 1900 CH661	5V	-35.78	-0.019
	4.5V	-34.82	-0.019
	4V	-33.73	-0.018
	3.5V	-29.58	-0.016
	3V	-34.26	-0.018

Mode	Temperature (°C)	Frequency error (Hz)	frequency error (ppm)
GSM 850 CH190	-10	19.74	0.024
	0	-20.67	-0.025
	10	-17.58	-0.021
	20	-15.62	-0.019
	30	-22.61	-0.027
	40	-18.34	-0.022
	50	-22.83	-0.027
PCS 1900 CH661	-10	65.68	0.035
	0	67.89	0.036
	10	72.15	0.038
	20	74.00	0.039
	30	71.58	0.038
	40	-53.68	-0.029
	50	-43.28	-0.023

7. Conducted spurious emissions

7.1. Block Diagram of Test Setup

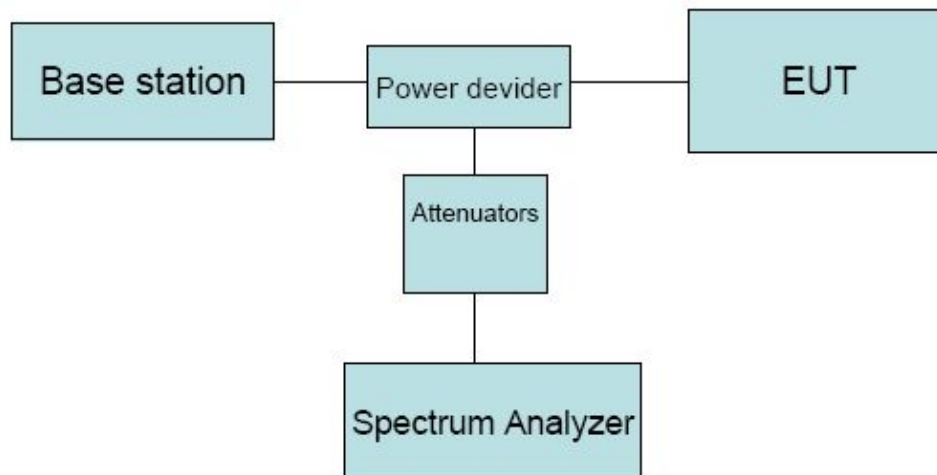

7.2. Limit

The mean power of emissions must be attenuated below the mean power of the unmodulated carrier (P) on any frequency outside the frequency band by at least $(43 + 10 \log P)$ dB, in this case, -13dBm.

7.3. Test Procedure

1. The EUT was connected to spectrum analyzer and base station via power divider.
2. The low, middle and high channels of each band and mode's spurious emissions for 30MHz to 10th Harmonic were measured by Spectrum analyzer.

7.4. Test Result

PASS

Test Mode: GSM 850 CH 128

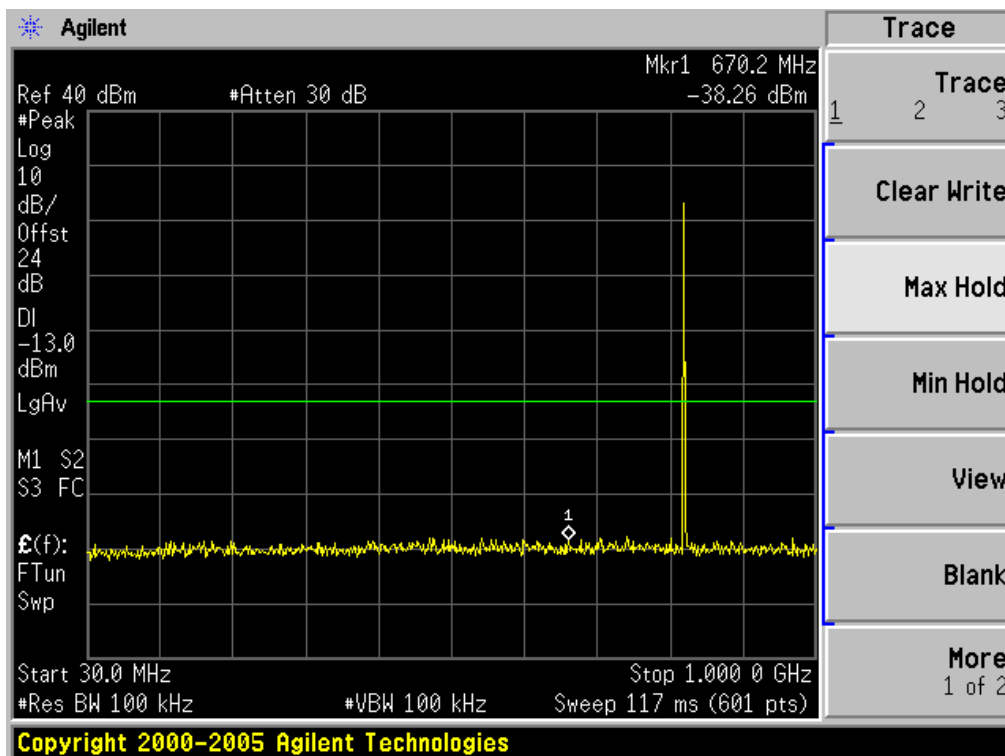
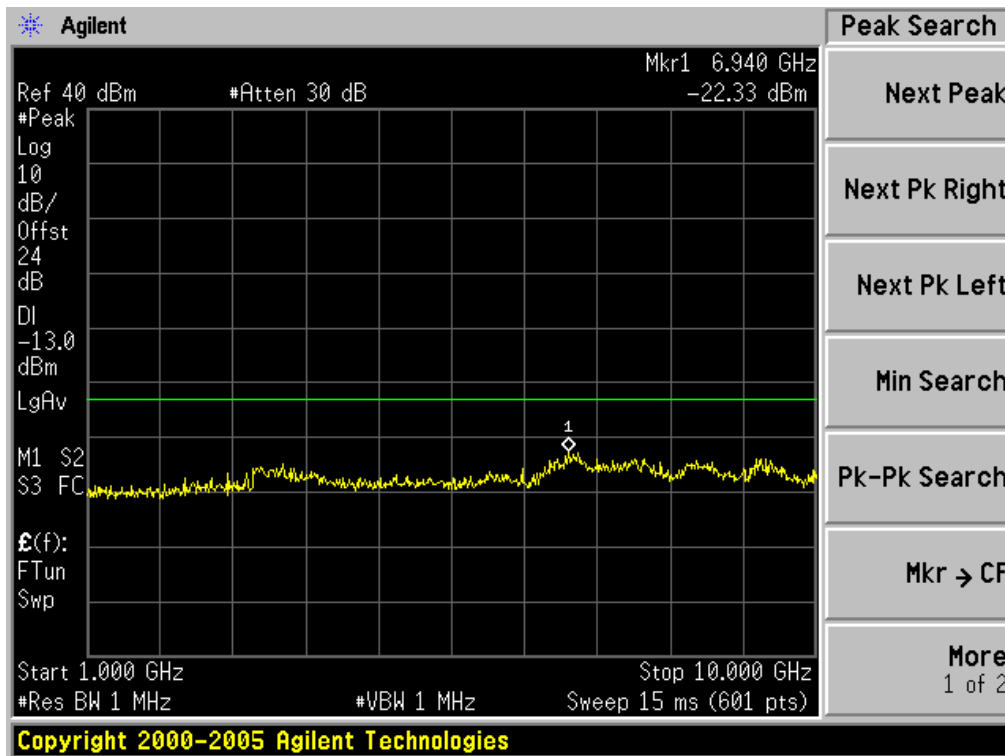

Test Mode: GSM 850 CH 190

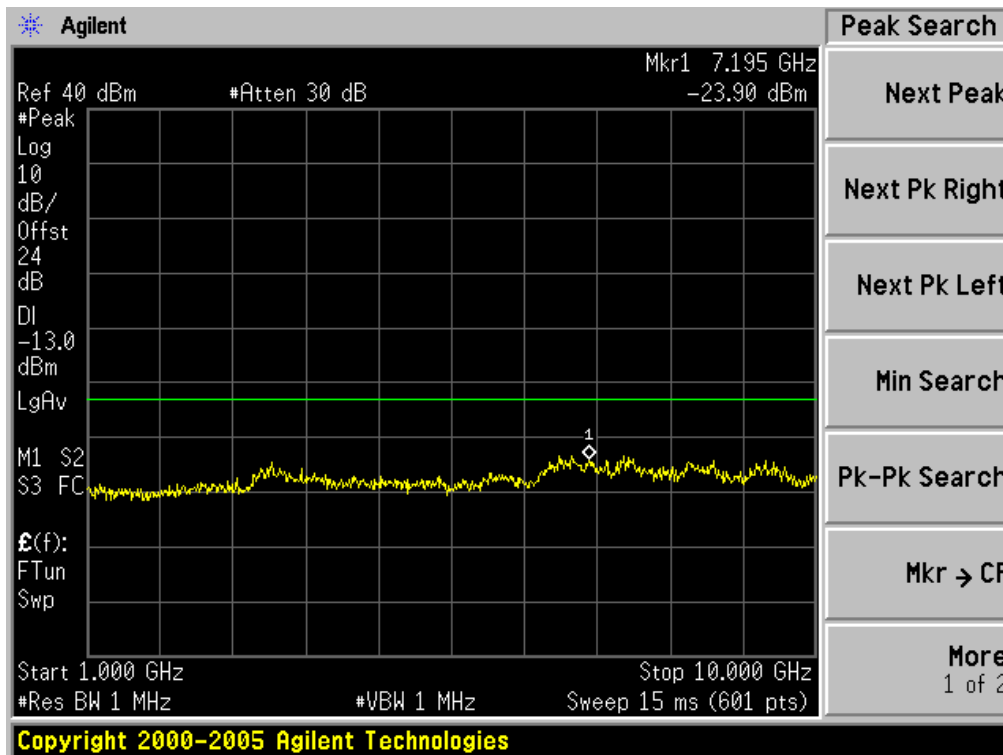
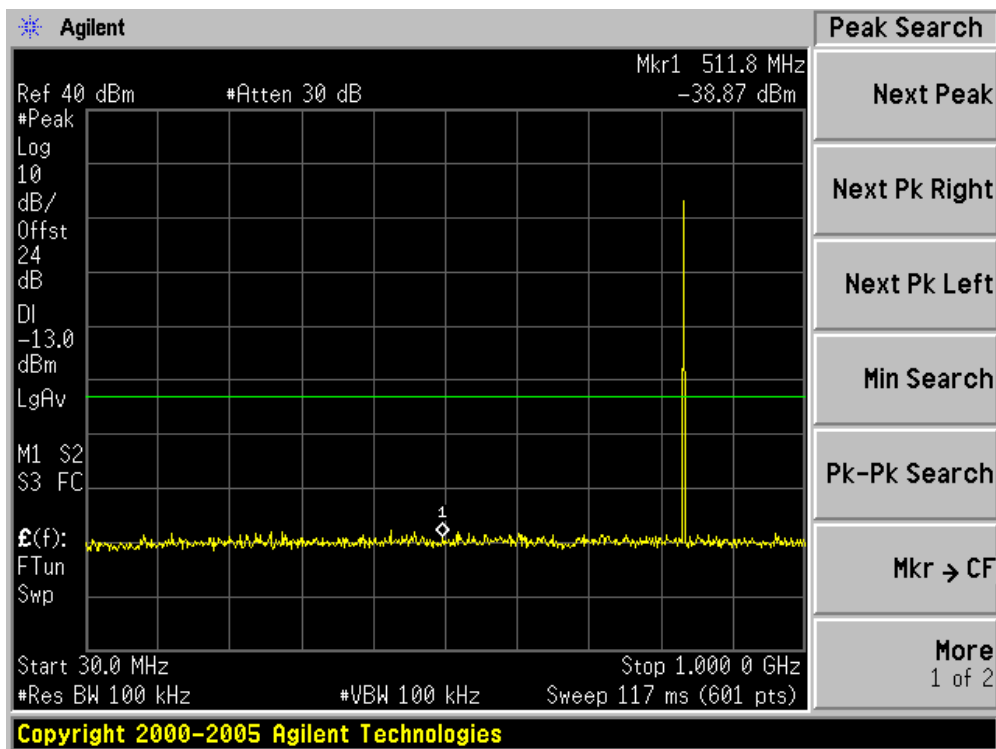

Test Mode: GSM 850 CH 251

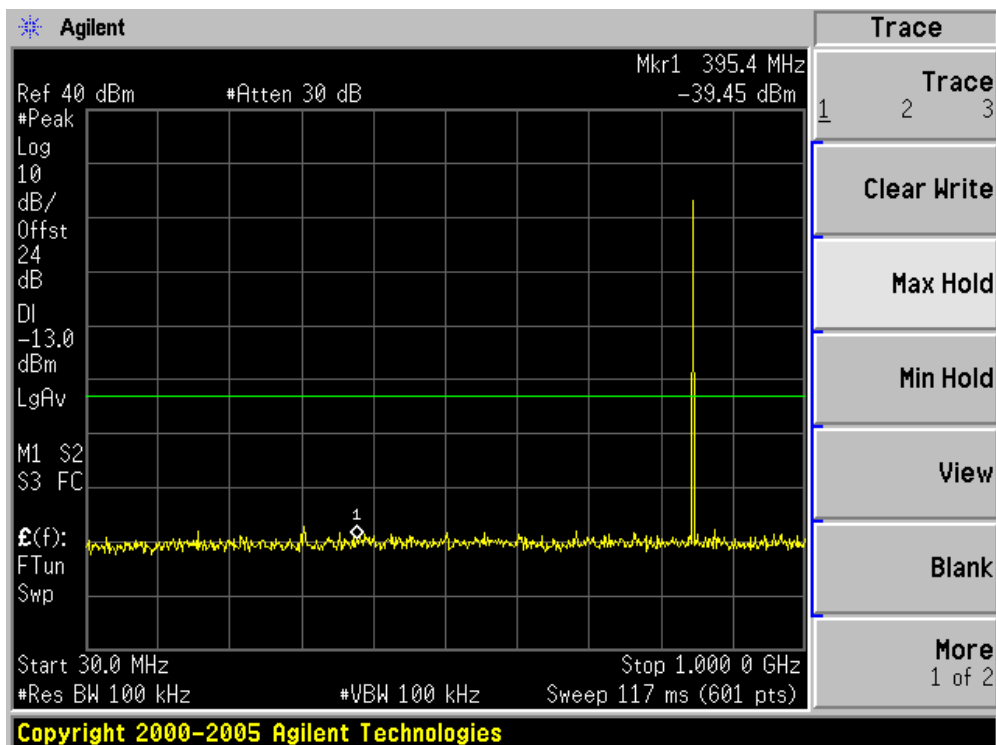
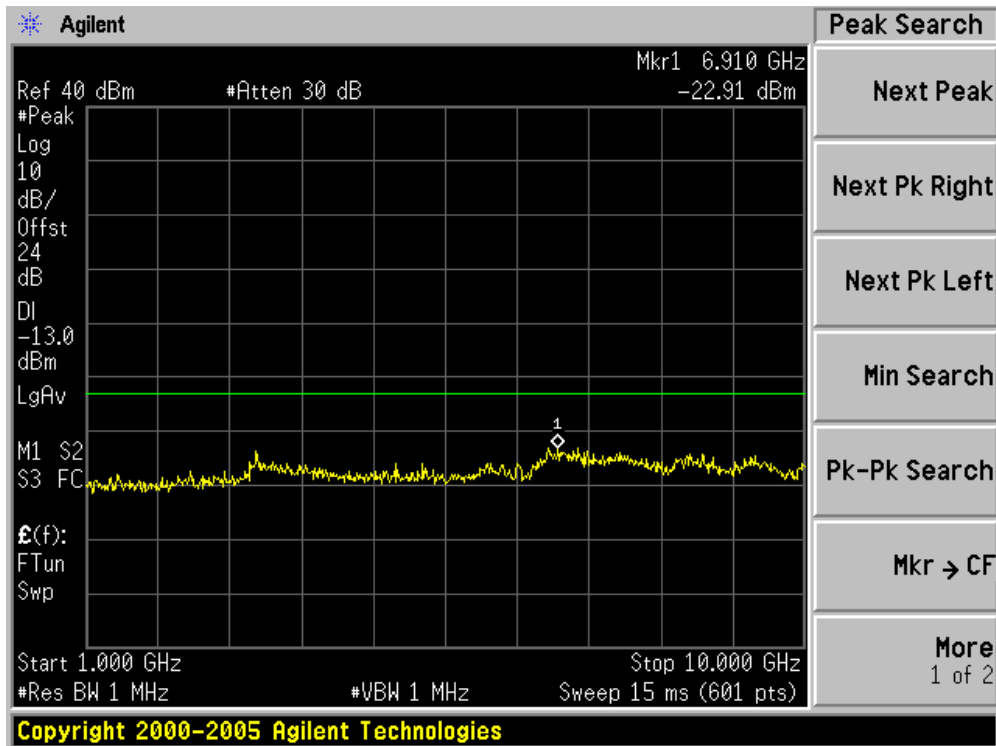

Test Mode: GSM 1900 CH 512

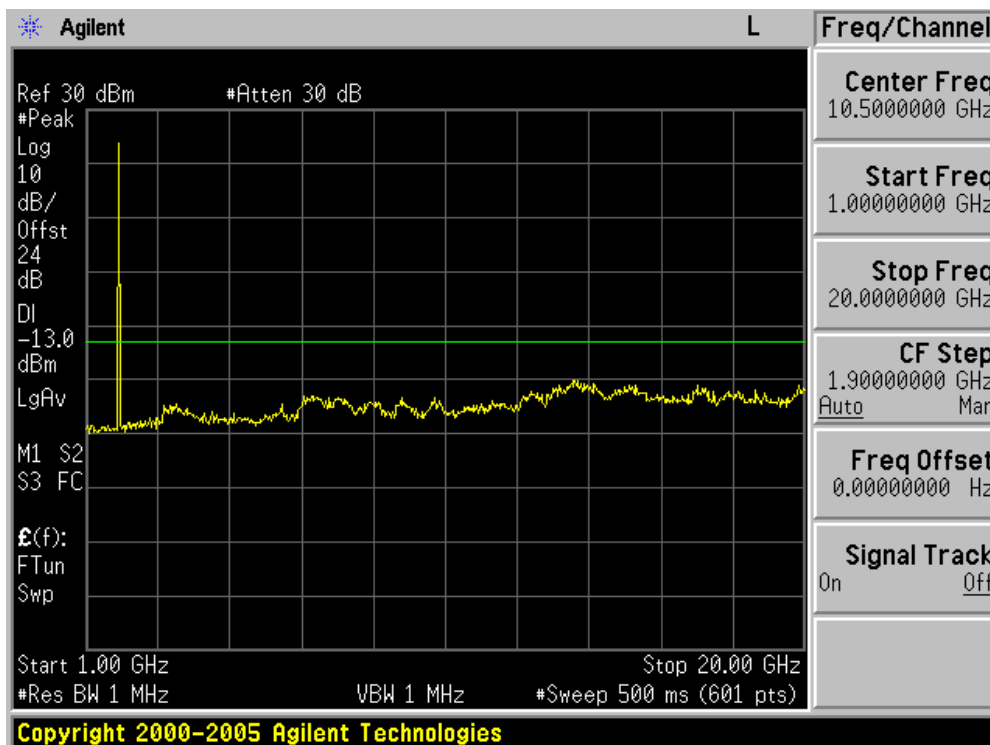
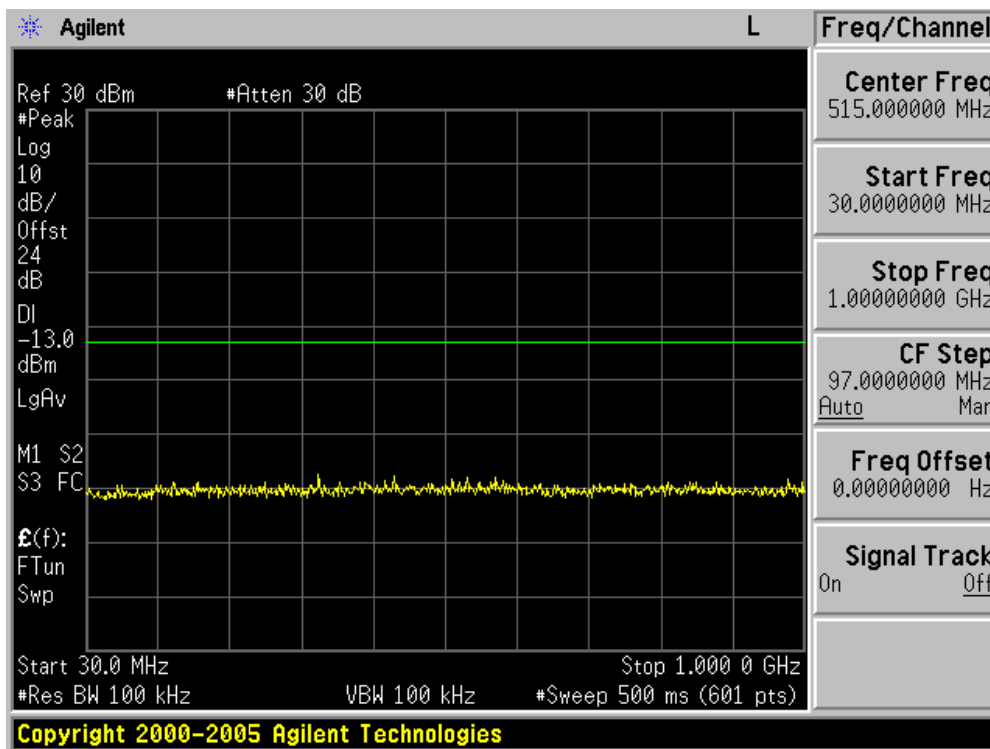

Test Mode: GSM 1900 CH 661

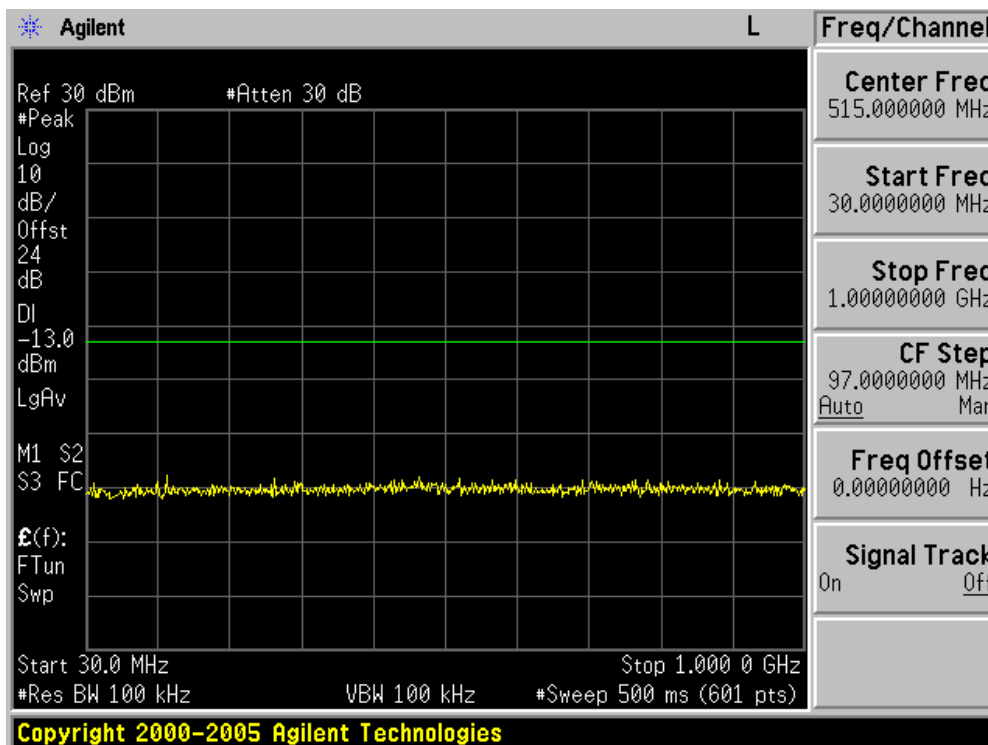
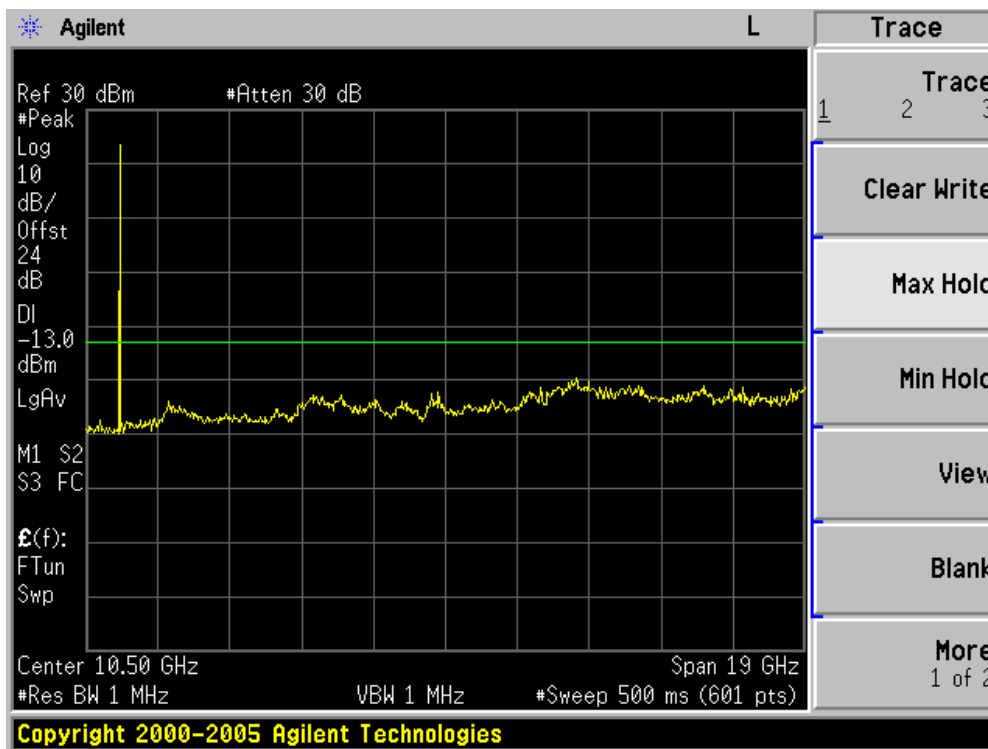

Test Mode: GSM 1900 CH 810

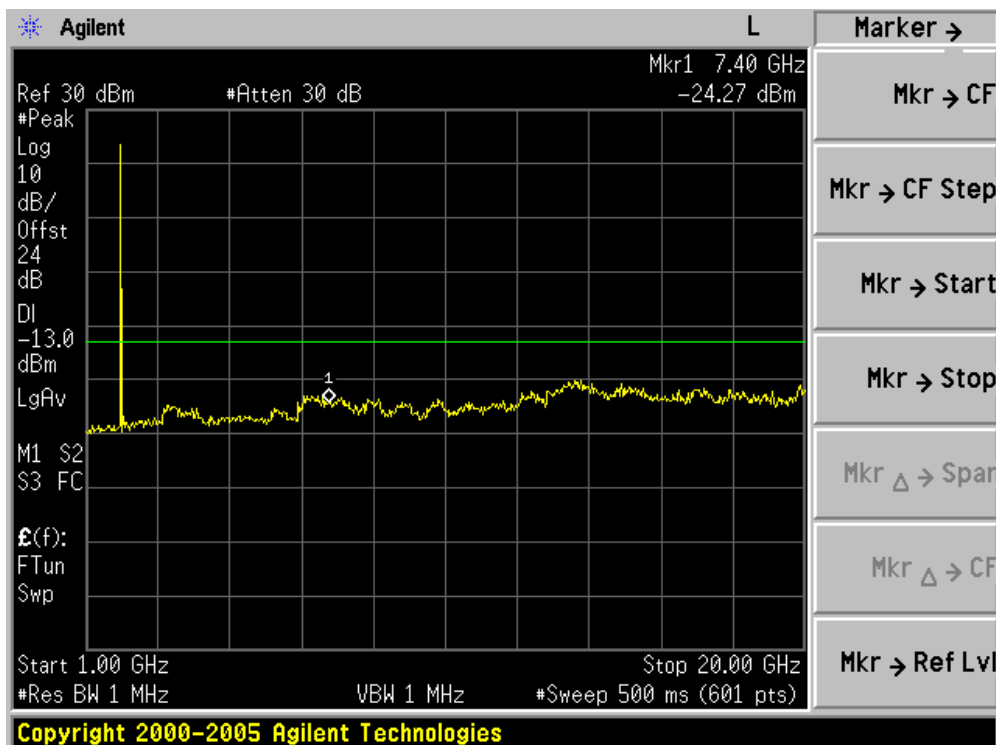
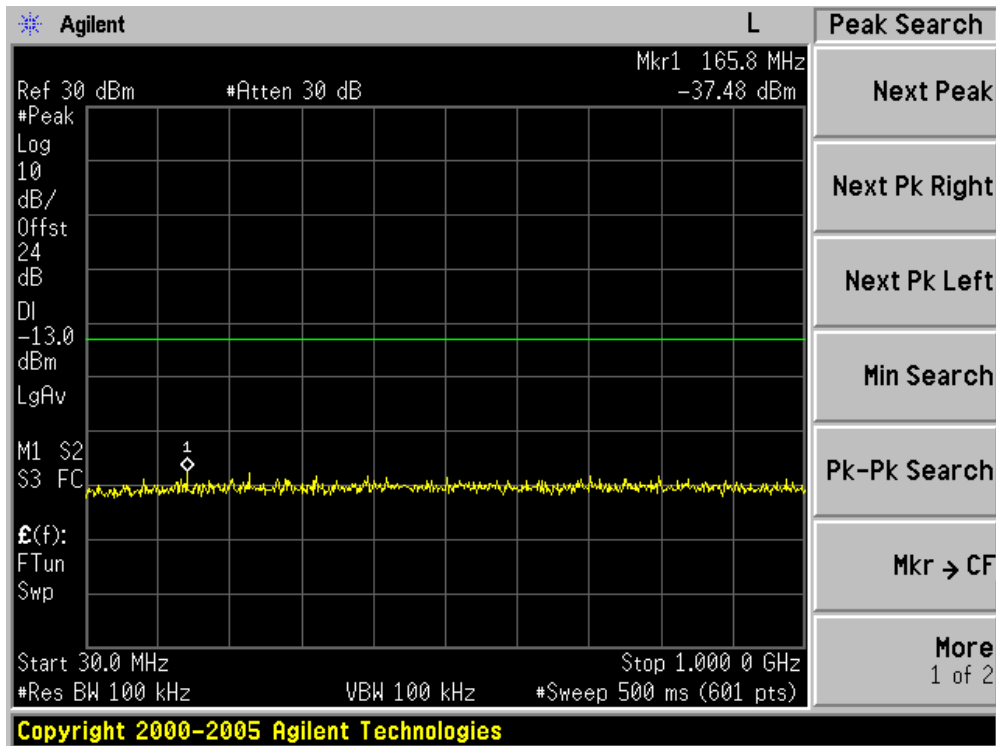

8. Radiated Spurious emissions

8.1. Block Diagram of Test Setup

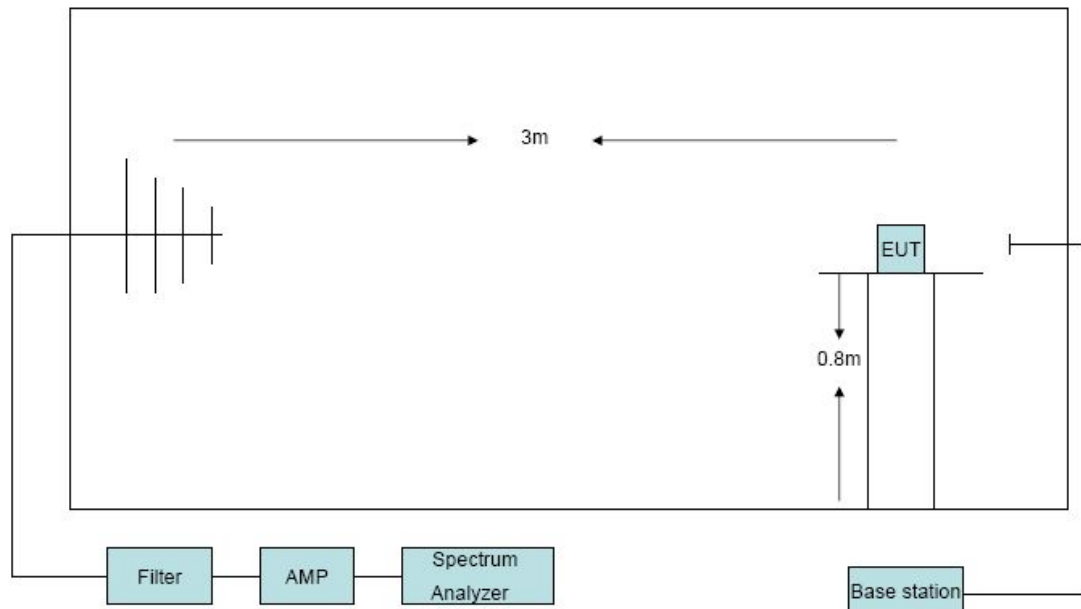

8.2. Limit

The mean power of emissions must be attenuated below the mean power of the unmodulated carrier (P) on any frequency outside the frequency band by at least $(43 + 10 \log P)$ dB, in this case, -13dBm.

8.3. Test Procedure

1. The EUT was placed on a non-conductive rotating platform with 0.8 meter height in an anechoic chamber. The radiated spurious emissions from 30MHz to 10th harmonic of fundamental frequency were measured at 3m with a test antenna and a spectrum analyzer with RBW= 1MHz, VBW= 1MHz, peak detector settings.
2. During the measurement, the EUT was enforced in maximum power and linked with a base station. All the spurious emissions (record as LVL) at 3m were measured by rotation of the turntable and the test antenna raised and lowered over a range from 1 to 4 meters in both horizontally and vertically polarized orientations.
3. Final spurious emissions levels were measured by substitution method according to TIA/EIA-603-C. The EUT was replaced by dipole antenna (for frequency below 1GHz) or Horn antenna (for frequency above 1GHz) at same location with same polarize of receiver antenna and then a known power of each measure frequency from S.G. was applied into the dipole antenna or Horn antenna through a Tx cable, and then recorded the maximum Analyzer reading through raised and lowered the test antenna. The correction

factor (in dB) = S.G. - Tx Cable loss + Substitution antenna gain –Substitution antenna Loss(only for Dipole antenna) - Analyzer reading. Then final

spurious emissions were calculated with the correction factor, EIRP= LVL + Correction factor and ERP = EIRP – 2.15

8.4. Test Result

EUT:2G Mobile Phone M/N:M.T.T. Protection 2G						
Power: DC 5V from adapter						
Test Date: 2013-09-30		Test site: RF Chamber		Tested by: Simple Guan		
Ambient Temperature: 24 ℃		Relative Humidity: 60%				
Conclusion: PASS						
Test result						
Test Mode: GSM 850 CH128						
Frequency (MHz)	Antenna polarization	LVL (dBm)	Correction factor(dB)	Result (ERP)(dBm)	Limit (dBm)	Margin (dB)
1648.4	H	-60.85	11.50	-51.50	-13.00	38.50
1648.4	V	-56.43	10.56	-48.02	-13.00	35.02
Test Mode: GSM 850 CH190						
1673.2	H	-61.57	10.94	-52.78	-13.00	39.78
2509.8	H	/	/	/	-13.00	/
1673.2	V	-55.53	10.90	-46.78	-13.00	33.78
2509.8	V	/	/	/	-13.00	/
Test mode: GSM 850 CH251						
1697.6	H	-59.84	11.67	-50.32	-13.00	37.32
2546.4	H	/	/	/	-13.00	/
1697.6	V	-56.49	11.13	-47.51	-13.00	34.51
2546.4	V	/	/	/	-13.00	/

Test Mode: GSM 1900 CH512						
Frequency (MHz)	Antenna polarization	LVL (dBm)	Correction factor(dB)	Result (EIRP)(dBm)	Limit (dBm)	Margin (dB)
3700.4	H	-54.32	8.57	-45.75	-13.00	32.75
5550.6	H	/	/	/	-13.00	/
3700.4	V	-50.34	8.37	-41.97	-13.00	28.97
5550.6	V	/	/	/	-13.00	/
Test Mode: GSM 1900 CH661						
3760	H	-54.23	8.75	-45.48	-13.00	32.48
5640	H	/	/	/	-13.00	/
3760	V	-53.22	8.55	-44.67	-13.00	31.67
5640	V	/	/	/	-13.00	/
Test mode: GSM 1900 CH810						
3819.6	H	-57.34	8.94	-48.40	-13.00	35.40
5729.4	H	/	/	/	-13.00	/
3819.6	V	-55.40	8.72	-46.68	-13.00	33.68
5729.4	V	/	/	/	-13.00	/
Note: All the other emissions not recorded were too low to read, and deemed to comply with limit.						

9. Block Edge Compliance

9.1. Block Diagram of Test Setup

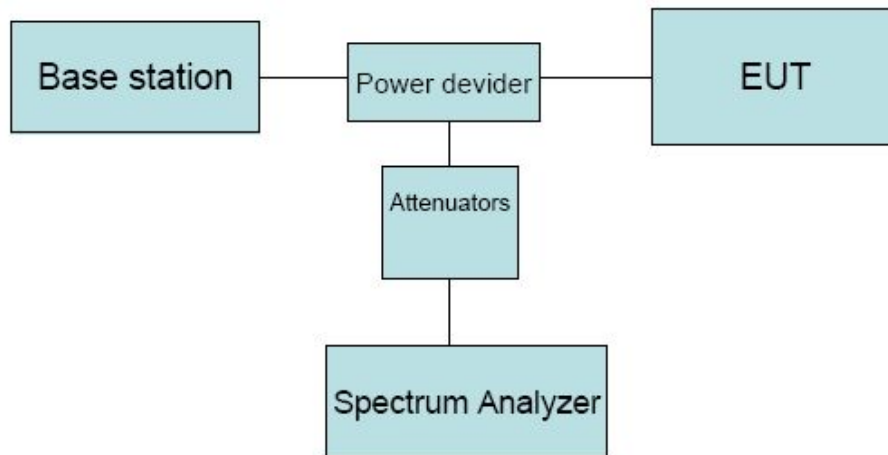

9.2. Limit

The mean power of emissions must be attenuated below the mean power of the unmodulated carrier (P) on any frequency outside the frequency band by at least $(43 + 10 \log P)$ dB, in this case, -13dBm.

9.3. Test Procedure

1. The EUT was connected to Spectrum Analyzer and Base Station via power divider.
2. The band edges of low and high channels for the highest RF powers were measured.

9.4. Test Result

PASS

Test Mode: GSM 850

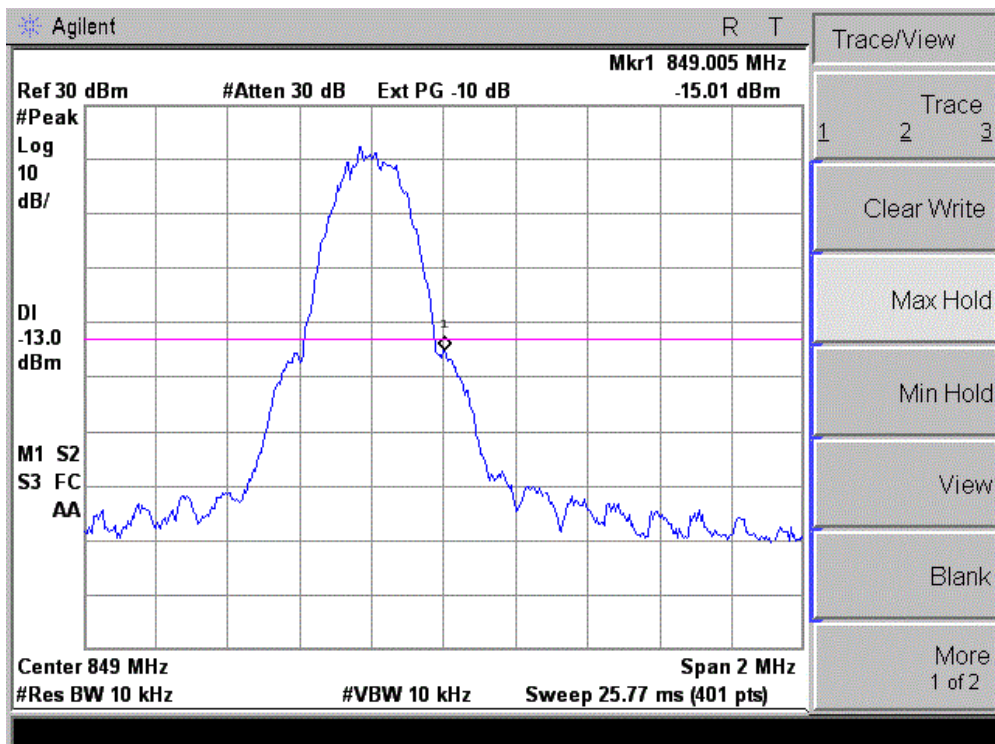
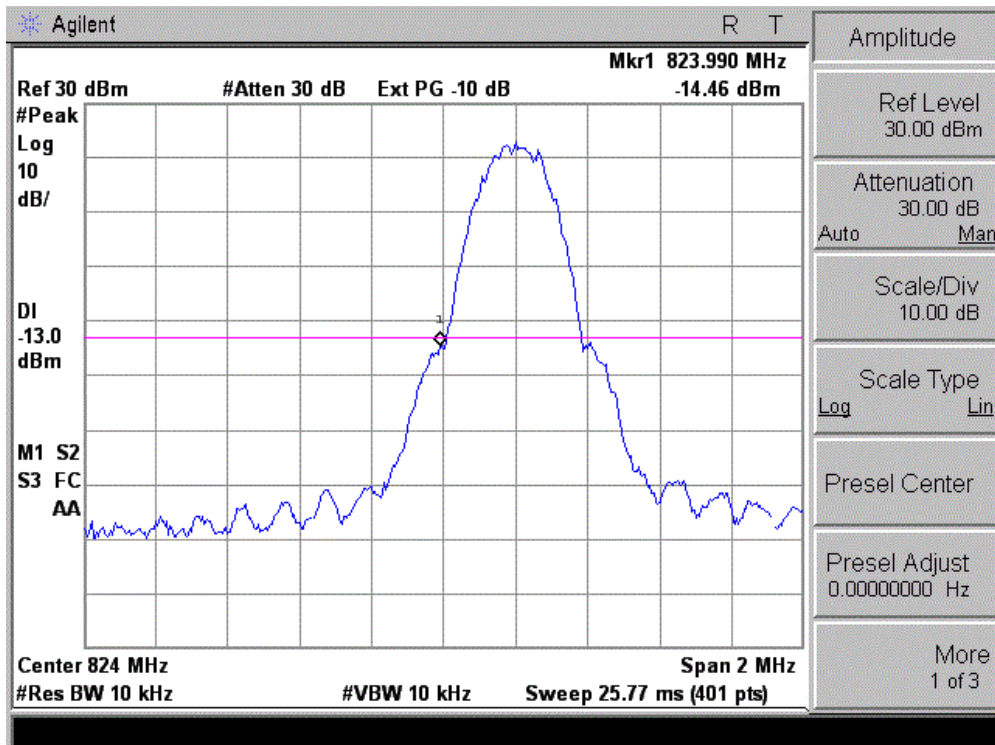

Test Mode: GSM 1900

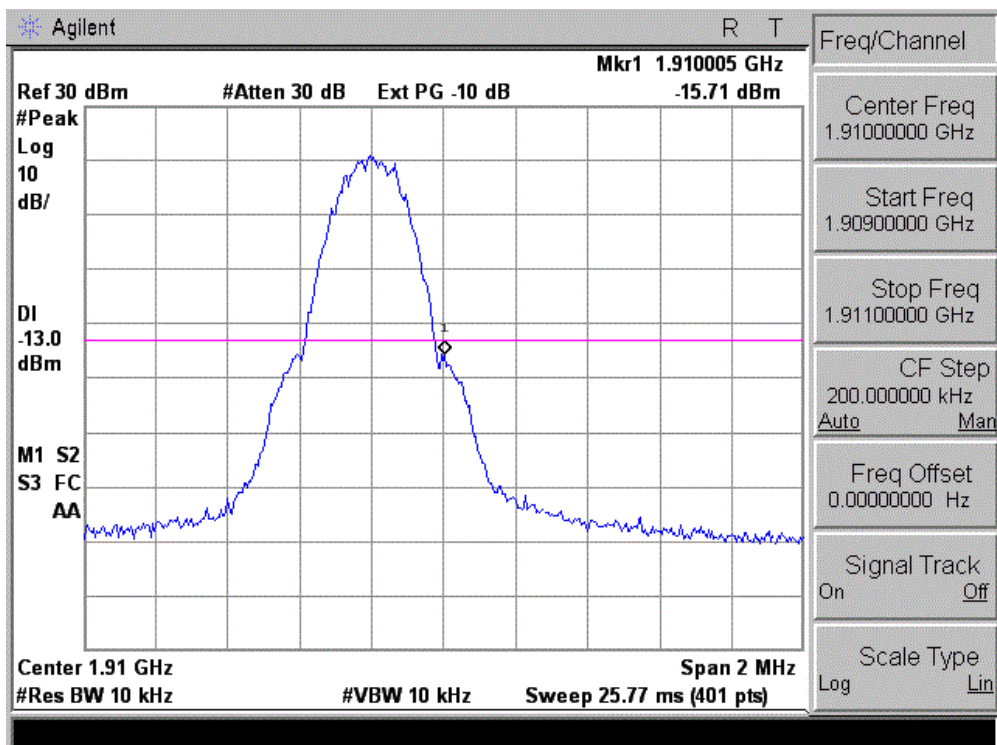
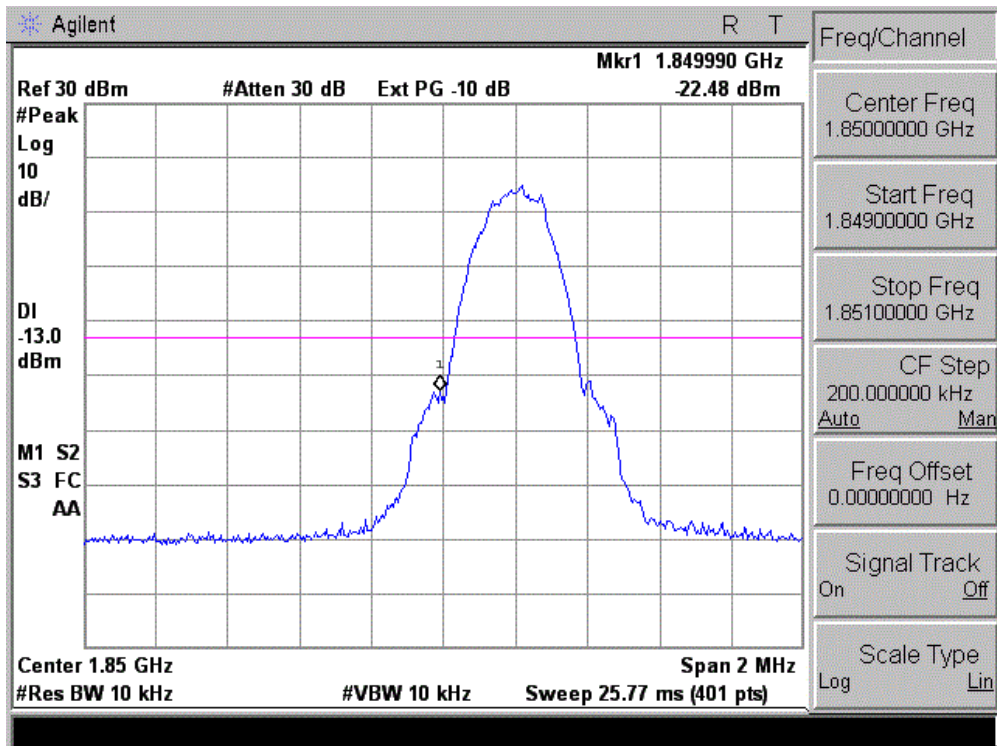

10. Power line conducted emission

10.1. Block Diagram of Test Setup

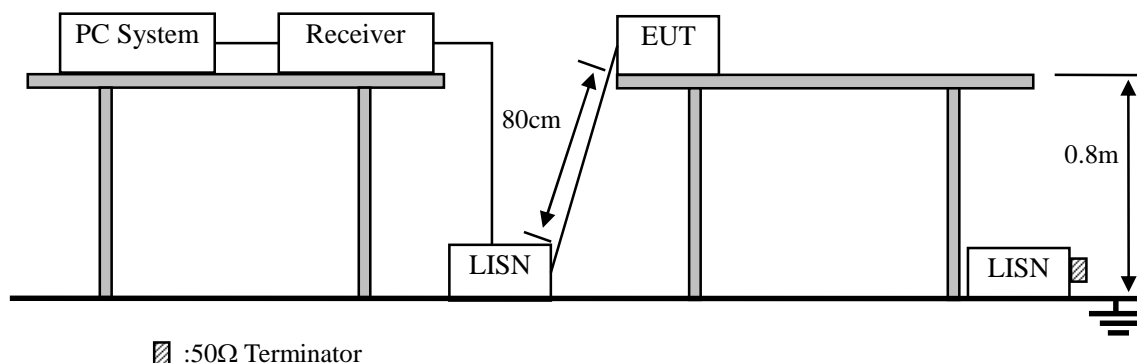

10.2. Limit

Frequency	Maximum RF Line Voltage	
	Quasi-Peak Level dB(μ V)	Average Level dB(μ V)
150kHz ~ 500kHz	66 ~ 56*	56 ~ 46*
500kHz ~ 5MHz	56	46
5MHz ~ 30MHz	60	50

- Notes: 1. * Decreasing linearly with logarithm of frequency.
 2. The lower limit shall apply at the transition frequencies.

10.3. Test Procedure

- (1) The EUT was placed on a non-metallic table, 80cm above the ground plane.
- (2) Setup the EUT and simulator as shown in 10.1
- (3) The EUT Power connected to the power mains through a power adapter and a line impedance stabilization network (L.I.S.N1). The other peripheral devices power cord connected to the power mains through a line impedance stabilization network (L.I.S.N1), this provided a 50-ohm coupling impedance for the EUT (Please refer to the block diagram of the test setup and photographs). Both sides of power line were checked for maximum conducted interference. In order to find the maximum emission, the relative positions of equipments and all of the interface cables were changed according to ANSI C63.4 2009 and ANSI C64.10:2009 on conducted Emission test.
- (4) The bandwidth of test receiver is set at 10KHz.
- (5) The frequency range from 150 KHz to 30MHz is checked.

10.4. Test Result

PASS. (See below detailed test data)



Shenzhen Certification Technology Service Co., Ltd.
 2F, Building B, East Area of Nanchang Second Industrial Zone,
 Gushu 2nd Road, Bao'an District, Shenzhen 518126, P.R. China
 Tel: 4006786199 Fax: +86-755-26736857
 Website: <http://www.cessz.com> Email: Service@cessz.com

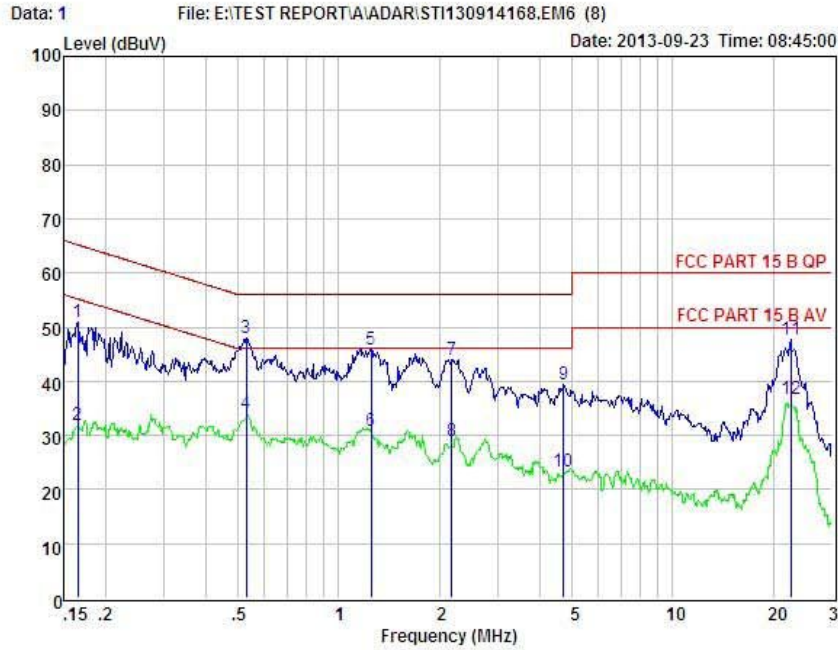

Condition : FCC PART 15 B QP POL: NEUTRAL Temp:24 °C Hum:56 %
 EUT : 2G Mobile Phone
 Model No : M.T.T. Protection 2G
 Test Mode : Charging
 Power : DC 5V From Adapter AC 120V/50Hz
 Test Engineer: Simple
 Remark :

Item	Freq MHz	Read dBuV	LISN Factor dB	Preamp Factor dB	Cable Loss dB	Level dBuV	Limit dBuV	Margin dBuV	Remark
1	0.165	41.02	0.03	-9.72	0.10	50.87	65.21	-14.34	QP
2	0.165	22.02	0.03	-9.72	0.10	31.87	55.21	-23.34	Average
3	0.529	38.09	0.03	-9.72	0.10	47.94	56.00	-8.06	QP
4	0.529	24.09	0.03	-9.72	0.10	33.94	46.00	-12.06	Average
5	1.249	36.05	0.04	-9.71	0.10	45.90	56.00	-10.10	QP
6	1.249	21.05	0.04	-9.71	0.10	30.90	46.00	-15.10	Average
7	2.178	34.11	0.06	-9.70	0.10	43.97	56.00	-12.03	QP
8	2.178	19.11	0.06	-9.70	0.10	28.97	46.00	-17.03	Average
9	4.721	29.49	0.10	-9.68	0.12	39.39	56.00	-16.61	QP
10	4.721	13.49	0.10	-9.68	0.12	23.39	46.00	-22.61	Average
11	22.655	37.23	0.41	-9.54	0.42	47.60	60.00	-12.40	QP
12	22.655	26.23	0.41	-9.54	0.42	36.60	50.00	-13.40	Average

Remarks: Level = Read + LISN Factor - Preamp Factor + Cable loss



Shenzhen Certification Technology Service Co., Ltd.
 2F, Building B, East Area of Nanchang Second Industrial Zone,
 Gushu 2nd Road, Bao'an District, Shenzhen 518126, P.R. China
 Tel: 4006786199 Fax: +86-755-26738857
 Website: http://www.cessz.com Email: Service@cessz.com

Data: 3 File: E:\TEST REPORT\ADAR\STI130914168.EM6 (8) Date: 2013-09-23 Time: 08:46:18

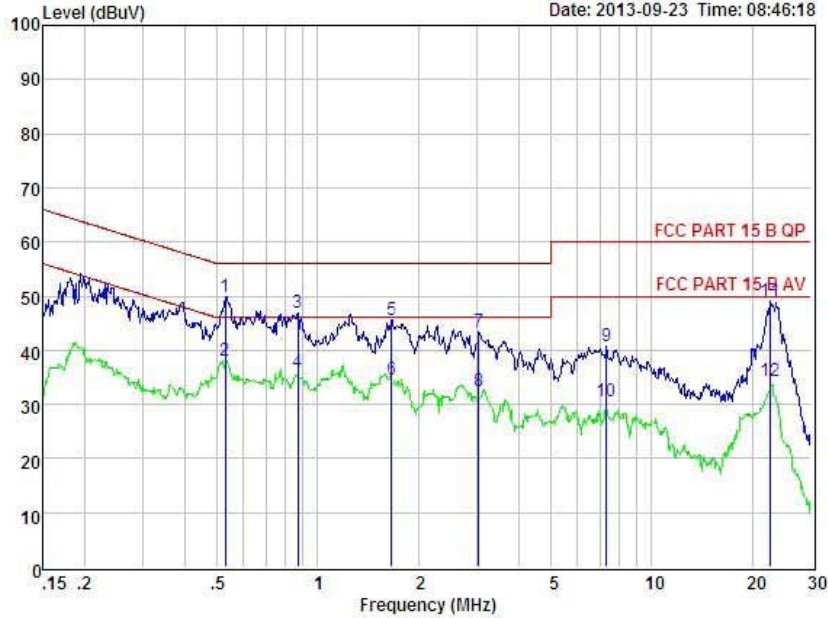

Condition : FCC PART 15 B QP POL: LINE Temp:24 °C Hum:56 %
 EUT : 2G Mobile Phone
 Model No : M.T.T. Protection 2G
 Test Mode : Charging
 Power : DC 5V From Adapter AC 120V/50Hz
 Test Engineer: Simple
 Remark :

Item	Freq MHz	Read dBuV	LISN Factor dB	Preamp Factor dB	Cable Loss dB	Level dBuV	Limit dBuV	Margin dBuV	Remark
1	0.529	40.12	0.03	-9.72	0.10	49.97	56.00	-6.03	QP
2	0.529	28.12	0.03	-9.72	0.10	37.97	46.00	-8.03	Average
3	0.871	36.95	0.04	-9.71	0.10	46.80	56.00	-9.20	QP
4	0.871	25.95	0.04	-9.71	0.10	35.80	46.00	-10.20	Average
5	1.662	35.81	0.05	-9.71	0.10	45.67	56.00	-10.33	QP
6	1.662	24.81	0.05	-9.71	0.10	34.67	46.00	-11.33	Average
7	3.041	33.48	0.07	-9.69	0.12	43.36	56.00	-12.64	QP
8	3.041	22.48	0.07	-9.69	0.12	32.36	46.00	-13.64	Average
9	7.329	30.90	0.13	-9.52	0.15	40.70	60.00	-19.30	QP
10	7.329	20.90	0.13	-9.52	0.15	30.70	50.00	-19.30	Average
11	22.775	38.80	0.41	-9.55	0.42	49.18	60.00	-10.82	QP
12	22.775	23.80	0.41	-9.55	0.42	34.18	50.00	-15.82	Average

Remarks: Level = Read + LISN Factor - Preamp Factor + Cable loss

11. Test setup photo

Photographs-Radiated Emission Test Setup in Chamber

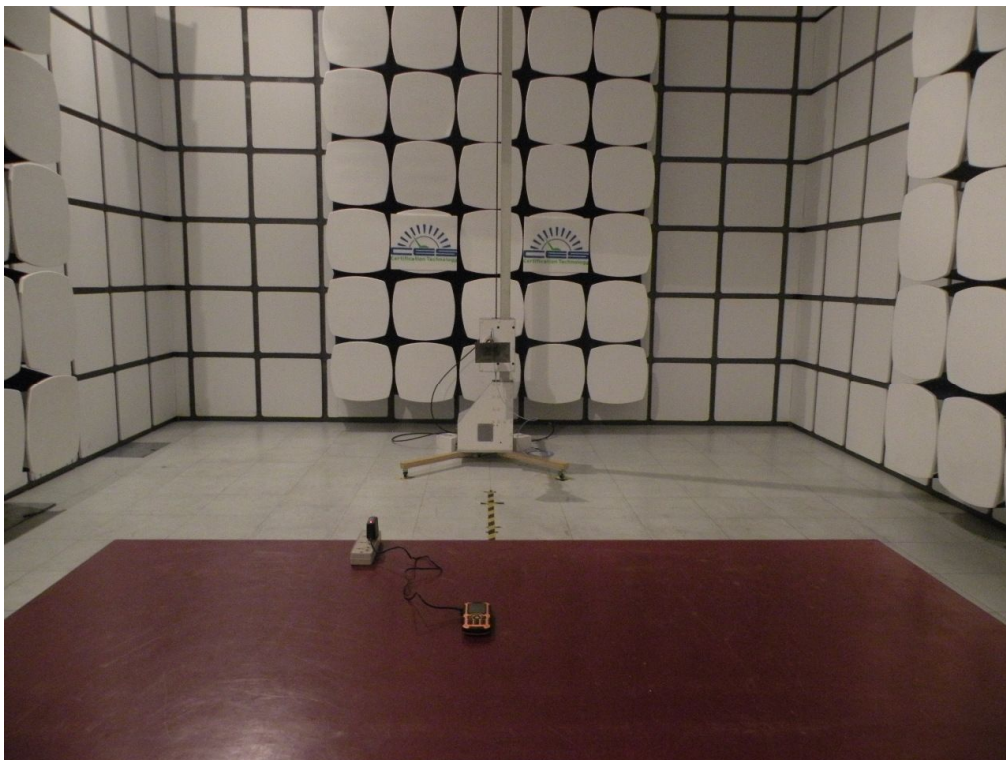
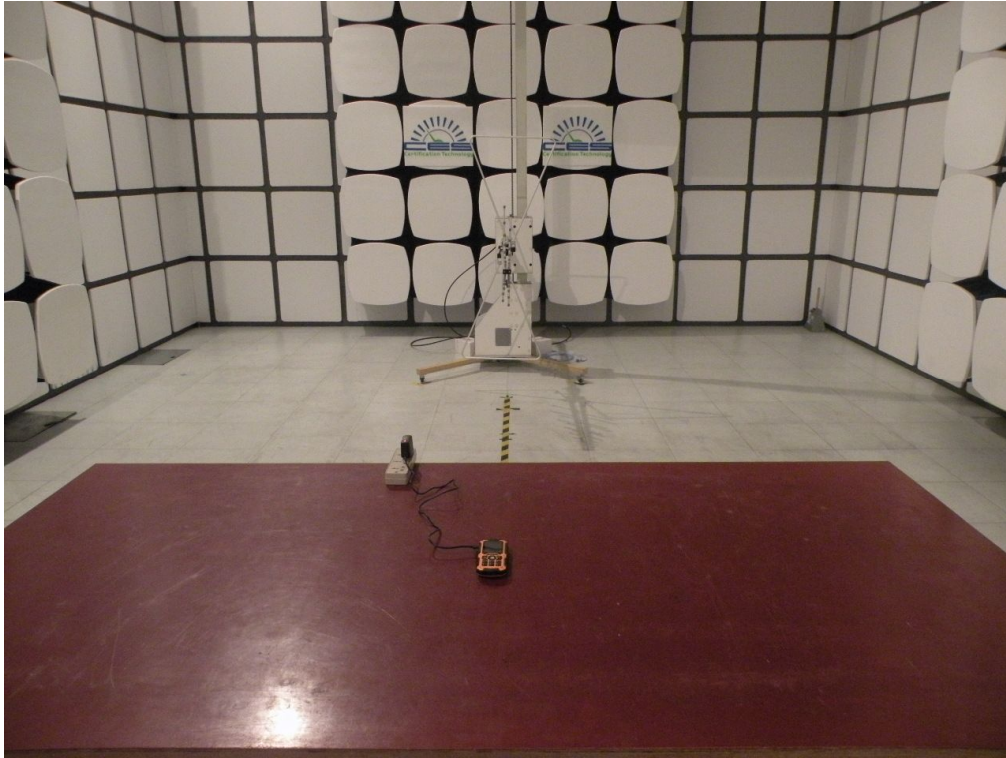

Photographs-Conducted Emission Test Setup

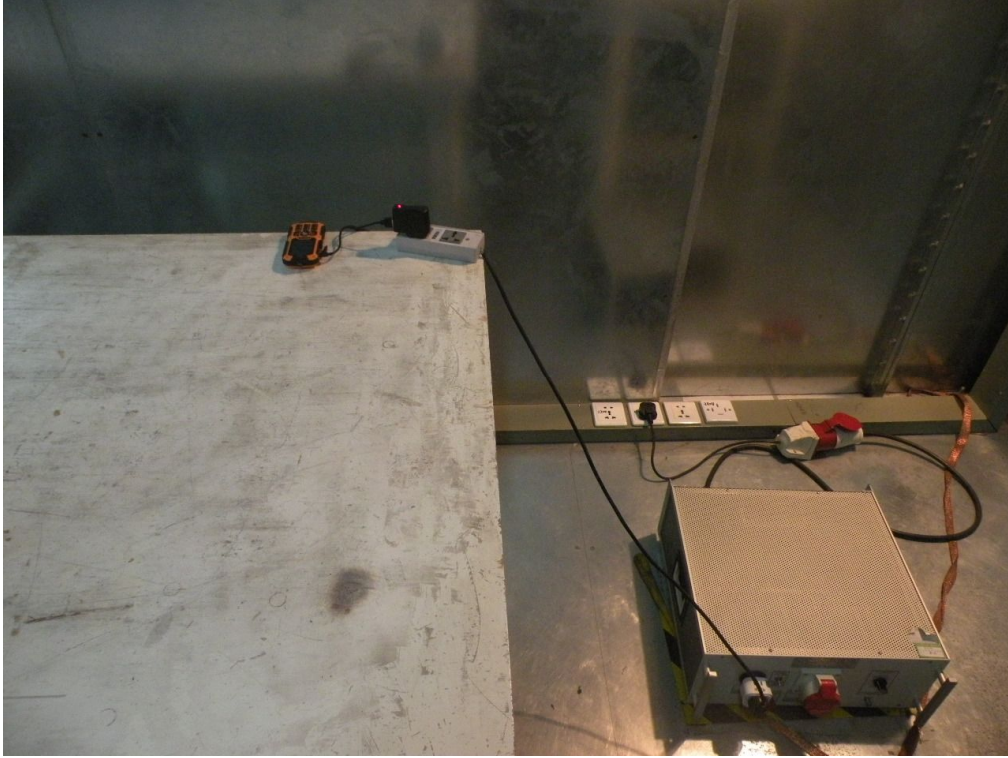

12. Photos of EUT











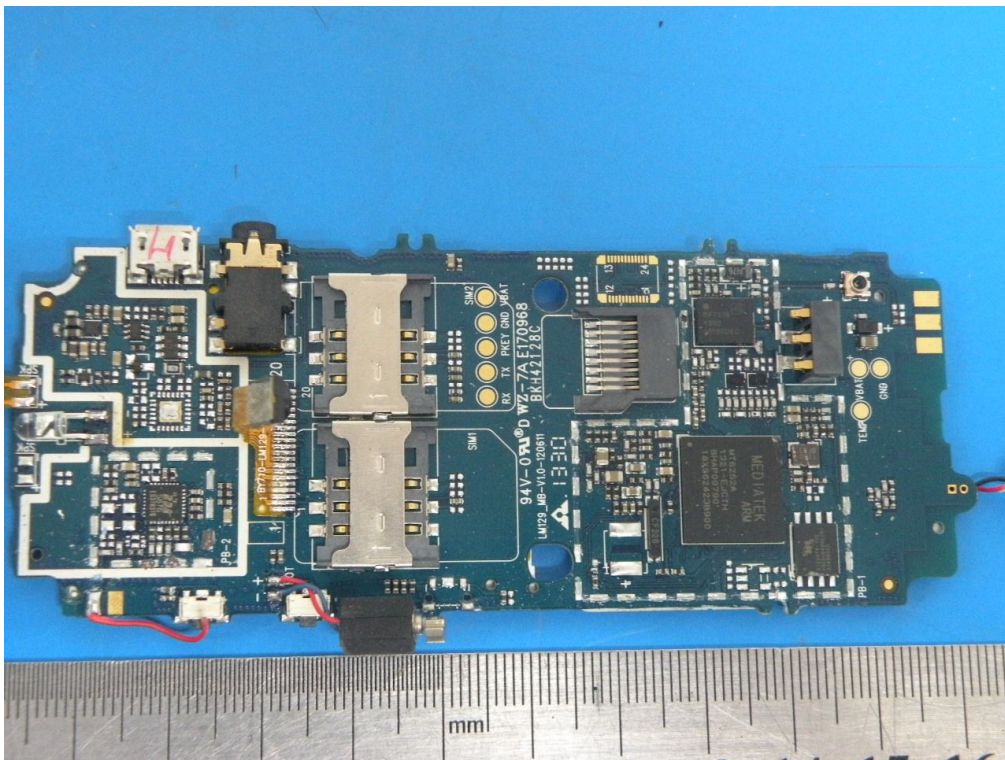
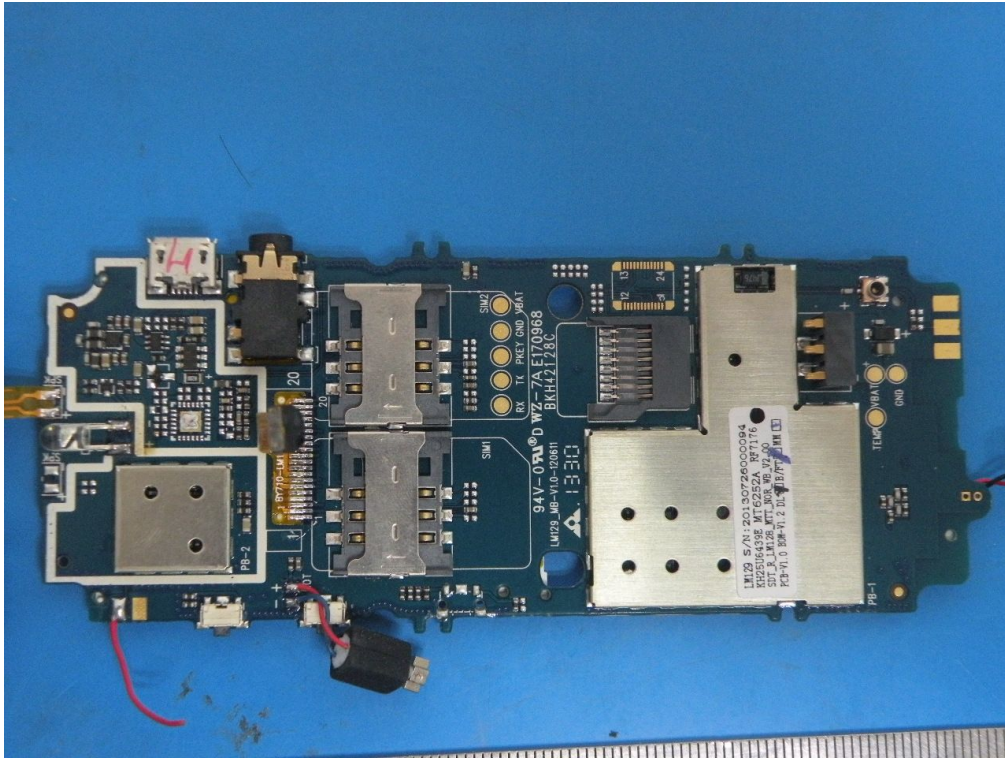

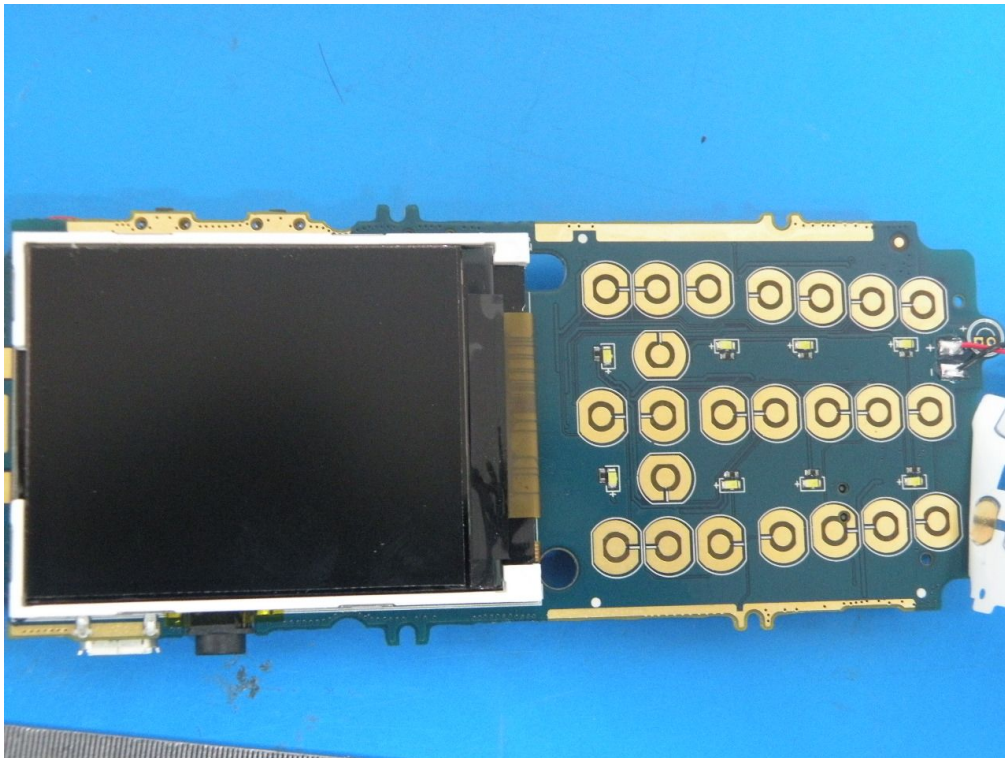

-----END OF THE REPORT-----