



FCC PART 15E TEST REPORT FOR CERTIFICATION
On Behalf of

CaptionCall, LLC

CaptionCall Wireless Router 2

CR2

FCC ID: 2AA6ZCR2

Prepared for : CaptionCall, LLC

4215 South Riverboat Road, Salt Lake City, UT 84123. USA.

Prepared By : Audix Technology (Shenzhen) Co., Ltd.

No. 6, Kefeng Road, Science & Technology Park,
Nanshan District , Shenzhen, Guangdong, China

Tel: (0755) 26639496

Report Number : ACS-F17035

Date of Test : Nov.24, 2016~Mar.18, 2017

Date of Report : Apr.18, 2017

TABLE OF CONTENTS

<u>Description</u>	<u>Page</u>
1. SUMMARY OF STANDARDS AND RESULTS	1-1
1.1. Description of Standards and Results	1-1
2. GENERAL INFORMATION	2-1
2.1. Description of Device (EUT)	2-1
2.2. Test Information	2-2
2.3. Tested Supporting System Details	2-3
2.4. Block diagram of connection between the EUT and simulators	2-3
2.5. Test Facility	2-4
2.6. Measurement Uncertainty (95% confidence levels, k=2)	2-4
3. POWER LINE CONDUCTED EMISSION TEST	3-1
3.1. Test Equipments	3-1
3.2. Block Diagram of Test Setup	3-1
3.3. Power Line Conducted Emission Test Limits	3-1
3.4. Configuration of EUT on Test	3-2
3.5. Operating Condition of EUT	3-2
3.6. Test Procedure	3-2
3.7. Power Line Conducted Emission Test Results	3-2
4. RADIATED EMISSION TEST	4-1
4.1. Test Equipment	4-1
4.2. Block Diagram of Test Setup	4-2
4.3. Radiated Emission Limit	4-3
4.4. EUT Configuration on Test	4-3
4.5. Operating Condition of EUT	4-4
4.6. Test Procedure	4-4
4.7. Radiated Emission Test Results	4-5
5. BAND EDGE COMPLIANCE TEST	5-1
5.1. Test Equipment	5-1
5.2. Limit	5-1
5.3. Test Produce	5-1
5.4. Test Results	5-1
6. 6dB&26dB Bandwidth Test.....	6-1
6.1. Test Equipment	6-1
6.2. Limit	6-1
6.3. Test Procedure	6-1
6.4. Test Results	6-1
7. OUTPUT POWER TEST	7-1
7.1. Test Equipment	7-1
7.2. Limit	7-1
7.3. Test Procedure	7-1
7.4. Test Results	7-2
8. SPECTRAL DENSITY TEST	8-1
8.1. Test Equipment	8-1
8.2. Limit	8-1
8.3. Test Procedure	8-1
8.4. Test Results	8-2
9. MPE ESTIMATION	9-1
9.1. Limit for General Population/ Uncontrolled Exposures	9-1
9.2. Estimation Result	9-1

10.	FREQUENCY STABILITY MEASUREMENT	10-1
10.1.	Test Equipment.....	10-1
10.2.	Limit	10-1
10.3.	Test Procedure.....	10-1
10.4.	Test Result.....	10-2
11.	ANTENNA REQUIREMENT	11-1
11.1.	Standard Applicable	11-1
11.2.	Antenna Connected Construction.....	11-1
12.	DEVIATION TO TEST SPECIFICATIONS	12-1
13.	PHOTOGRAPH OF TEST.....	13-1
13.1.	Photos of Power Line Conducted Emission Test.....	13-1
13.2.	Photos of Radiated Emission Test.....	13-2
14.	PHOTOGRAPHS OF EUT.....	14-1

TEST REPORT CERTIFICATION

Applicant : CaptionCall, LLC
Manufacturer : HUNAN FULLRIVER HIGH TECHNOLOGY CO., LTD.
Product : CaptionCall Wireless Router 2
FCC ID : 2AA6ZCR2
(A) Model No. : CR2
(B) Power Supply : DC 9V
(C) Test Voltage : DC 9V From Adapter Input AC 120V/60Hz

Tested for comply with:
FCC CFR47 Part 15 Subpart E

Test procedure used:
ANSI C63.10: 2013
KDB789033D01

The device described above is tested by AUDIX TECHNOLOGY (SHENZHEN) CO., LTD. to confirm comply with all the FCC Part 15 Subpart E requirements. The test results are contained in this test report and AUDIX TECHNOLOGY (SHENZHEN) CO., LTD. is assumed full responsibility for the accuracy and completeness of these tests. Also, this report shows that the Equipment Under Test (EUT) is to be technically compliant with the FCC and IC requirements. This report contains data that are not covered by the NVLAP accreditation.

This Report is made under FCC Part 2.1075. No modifications were required during testing to bring this product into compliance.

This report applies to above tested sample only. This report shall not be reproduced in part without written approval of AUDIX TECHNOLOGY (SHENZHEN) CO., LTD.

The report must not be used by the client to claim product certification, approval, or endorsement by NVLAP, NIST, or any agency of the federal government.

Date of Test : Nov.24, 2016~Mar.18, 2017 Report of date: Apr.18, 2017

Prepared by : Monica Liu Reviewed by : Sunny Lu
Monica Liu / Assistant Sunny Lu / Deputy Manager



Approved & Authorized Signer :

1. SUMMARY OF STANDARDS AND RESULTS

1.1. Description of Standards and Results

The EUT have been tested according to the applicable standards as referenced below.

EMISSION		
Description of Test Item	Standard	Results
Power Line Conducted Emission	FCC Part 15: 15.207	PASS
Radiated Emission	FCC Part 15: 15.209	PASS
Band Edge Compliance	FCC Part 15: 15.407	PASS
6dB&26Bandwidth Test	FCC Part 15: 15.407(a)	PASS
Output Power Test	FCC Part 15: 15.407(a)	PASS
Power Spectral Density Test	FCC Part 15: 15.407(a)	PASS
Frequency Stability	FCC Part 15: 15.407(g)	PASS
Antenna requirement	FCC Part 15: 15.203	PASS

N/A is an abbreviation for Not Applicable.

2. GENERAL INFORMATION

2.1. Description of Device (EUT)

Product	: CaptionCall Wireless Router 2
Model No.	: CR2
FCC ID	: 2AA6ZCR2
Radio	: IEEE802.11 a/b/g/n/ac
Operation Frequency	: IEEE 802.11a: 5180MHz—5240MHz; 5745MHz—5825MHz IEEE 802.11ac VHT20: 5180MHz—5240MHz; 5745MHz—5825MHz IEEE 802.11ac VHT40: 5190MHz—5230MHz; 5755MHz—5795MHz IEEE 802.11ac VHT80: 5210MHz; 5775MHz IEEE 802.11b: 2412MHz—2462MHz IEEE 802.11g: 2412MHz—2462MHz IEEE802.11nHT20: 2412MHz—2462MHz; 5180MHz—5240MHz; 5745MHz—5825MHz IEEE802.11nHT40: 2422MHz—2452MHz; 5190MHz—5230MHz; 5755MHz—5795MHz
Modulation Technology	: IEEE 802.11b: DSSS(CCK,DQPSK,DBPSK) IEEE 802.11a/g: OFDM(64QAM, 16QAM, QPSK, BPSK) IEEE 802.11ac VHT20, VHT40, VHT80: OFDM(16QAM, 64QAM, 256QAM, QPSK, BPSK) IEEE 802.11n HT20, HT40: OFDM (64QAM, 16QAM,QPSK,BPSK)
Antenna Assembly Gain	: Antenna Type: PCBA Antenna, WIFI 2.4GHz: ANT A: 2dBi gain; Antenna Type: Dipole Antenna, WIFI 2.4GHz: ANT B: 5dBi gain; WIFI 5GHz: ANT: 5dBi gain
Applicant	: CaptionCall, LLC 4215 South Riverboat Road, Salt Lake City, UT 84123. USA.
Manufacturer	: HUNAN FULLRIVER HIGH TECHNOLOGY CO., LTD. FullRiver Industrial Area Economic Development Zone LiLing City HuNan Province China
Factory	: HUNAN FULLRIVER HIGH TECHNOLOGY CO., LTD. FullRiver Industrial Area Economic Development Zone LiLing City HuNan Province China

Power Adapter : Manufacturer: AMIGO, M/N: AMS135-0901000FU
 Input: 100-240Vac; 50/60Hz, 0.5A
 Output: 9V; 1A
 DC Cable: Shielded, Undetachable, 1.5m

Date of Test : Nov.24, 2016~Mar.18, 2017

Date of Receipt : Nov.22, 2016

2.2. Test Information

A special test software was used to control EUT work in Continuous TX mode (nearly 100% duty cycle), and select test channel, wireless mode and data rate.

Tested mode, channel, and data rate information			
Mode	data rate (Mbps)(see Note)	Channel	Frequency (MHz)
IEEE 802.11a	6	Low :CH36	5180
	6	Middle: CH40	5200
	6	High: CH48	5240
	6	Low :CH149	5745
	6	Middle: CH157	5785
	6	High: CH165	5825
IEEE 802.11nHT20	MCS0	Low :CH36	5180
	MCS0	Middle: CH40	5200
	MCS0	High: CH48	5240
	MCS0	Low :CH149	5745
	MCS0	Middle: CH157	5785
	MCS0	High: CH165	5825
IEEE 802.11nHT40	MCS0	Low :CH38	5190
	MCS0	High: CH46	5230
	MCS0	Low :CH151	5755
	MCS0	High: CH159	5795
IEEE 802.11acVHT20	MCS0	Low :CH36	5180
	MCS0	Middle: CH40	5200
	MCS0	High: CH48	5240
	MCS0	Low :CH149	5745
	MCS0	Middle: CH157	5785
	MCS0	High: CH165	5825
IEEE 802.11acVHT40	MCS0	Low :CH38	5190
	MCS0	High: CH46	5230
	MCS0	Low :CH151	5755
	MCS0	High: CH159	5795
IEEE 802.11acVHT80	MCS0	CH42	5210
	MCS0	CH155	5775
Note: 1. According exploratory test, EUT will have maximum output power in those data rate, so those data rate were used for all test.			

2.3. Tested Supporting System Details

No.	Description	ACS No.	Manufacturer	Model	Serial Number
1.	Notebook	N/A	DELL	PP09S	N/A
		Power Cord: Unshielded, Detachable, 1.8m Power Adapter: Manufacturer: DELL, M/N: LA65NS1-00 Cable: Unshielded, Detachable, 4.0m(Bond one ferrite core)			
2.	LAN Cable	Unshielded, Detachable, 15m			

2.4. Block diagram of connection between the EUT and simulators

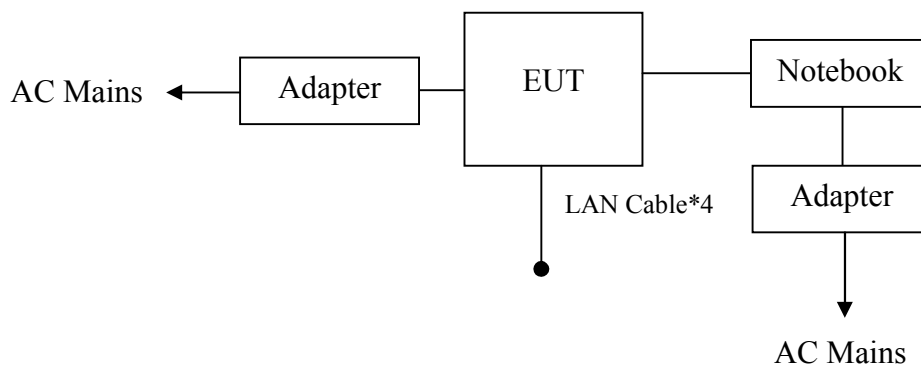

(EUT: CaptionCall Wireless Router 2)

2.5. Test Facility

Site Description

Name of Firm : Audix Technology (Shenzhen) Co., Ltd.
 No. 6, Kefeng Road, Science & Technology Park, Nanshan District , Shenzhen, Guangdong, China

3m Anechoic Chamber : Certificated by FCC, USA
 Registration Number: 90454
 Valid Date: Jul.12, 2017

3m & 10m Anechoic Chamber : Certificated by FCC, USA
 Registration Number: 794232
 Valid Date: Jul.12, 2017

EMC Lab. : Certificated by Industry Canada
 Registration Number: IC 5183A-1
 Valid Date: May.14, 2017

: Certificated by DAkkS, Germany
 Registration No: D-PL-12151-01-00
 Valid Date: Dec.07, 2021

: Accredited by NVLAP, USA
 NVLAP Code: 200372-0
 Valid Date: Mar.31, 2018

2.6. Measurement Uncertainty (95% confidence levels, k=2)

Test Item	Uncertainty
Uncertainty for Conduction emission test in No. 1 Conduction	3.2dB (150kHz to 30MHz)
Uncertainty for Radiation Emission test in 3m chamber	2.8dB(30~200MHz, Polarization: H)
	2.8dB(30~200MHz, Polarization: V)
	3.0dB(200M~1GHz, Polarization: H)
	3.0dB(200M~1GHz, Polarization: V)
Uncertainty for Radiation Emission test in 3m chamber (1GHz-18GHz)	5.8dB(1~6GHz, Distance: 3m)
	5.8dB(6~18GHz, Distance: 3m)
Uncertainty for Radiated Spurious Emission test in RF chamber	3.6dB
Uncertainty for Conduction Spurious emission test	2.0dB
Uncertainty for Output power test	0.8dB
Uncertainty for Bandwidth test	83 kHz
Uncertainty for DC power test	0.1%
Uncertainty for test site temperature and humidity	0.6°C
	3%

3. POWER LINE CONDUCTED EMISSION TEST

3.1. Test Equipments

Item	Equipment	Manufacturer	Model No.	Serial No.	Last Cal.	Cal. Interval
1.	1# Shielding Room	AUDIX	N/A	N/A	Apr.17,16	1 Year
2.	Test Receiver	Rohde & Schwarz	ESCI	100842	Apr.24,16	1 Year
3.	L.I.S.N.#1	Rohde & Schwarz	ESH2-Z5	100429	Oct.15,16	1 Year
4.	L.I.S.N.#2	Kyoritsu	K NW-403D	8-1750-2	Apr.24,16	1 Year
5.	Terminator	Hubersuhner	50Ω	No.1	May.05.16	1 Year
6.	Terminator	Hubersuhner	50Ω	No.2	May.05.16	1 Year
7.	RF Cable	MIYAZAKI	3D-2W	No.1	Apr.24,16	1Year
8.	Coaxial Switch	Anritsu	MP59B	6200766906	Apr.23,16	1 Year
9.	Test Software	AUDIX	e3	6.100913a	N/A	N/A

Note: N/A means Not applicable.

3.2. Block Diagram of Test Setup

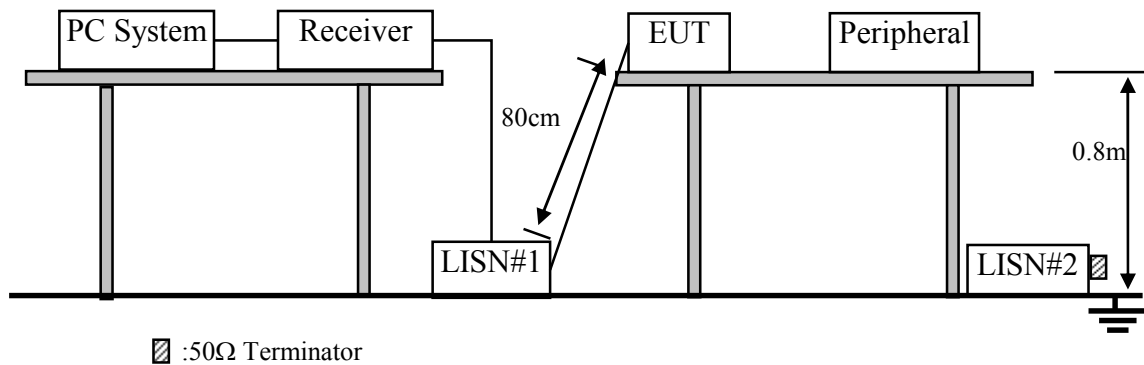

3.3. Power Line Conducted Emission Test Limits

Frequency	Maximum RF Line Voltage	
	Quasi-Peak Level dB(μV)	Average Level dB(μV)
150kHz ~ 500kHz	66 ~ 56*	56 ~ 46*
500kHz ~ 5MHz	56	46
5MHz ~ 30MHz	60	50

Notes: 1. * Decreasing linearly with logarithm of frequency.

2. The lower limit shall apply at the transition frequencies.

3.4. Configuration of EUT on Test

The following equipment are installed on Power Line Conducted Emission Test to meet the commission requirement and operating regulations in a manner which tends to maximize its emission characteristics in a normal application.

3.4.1. CaptionCall Wireless Router 2 (EUT)

Model No. : CR2
Serial No. : N/A

3.4.2. Support Equipment: As Tested Supporting System Details, in Section 2.2.

3.5. Operating Condition of EUT

3.5.1. Setup the EUT and simulator as shown as Section 3.2.

3.5.2. Turn on the power of all equipments.

3.5.3. PC run test software to control EUT work in Tx mode.

3.6. Test Procedure

The EUT was placed on a non-metallic table, 80cm above the ground plane. The EUT Power Via PC connected to the power mains through a line impedance stabilization network (L.I.S.N. 1#). This provides a 50 ohm coupling impedance for the EUT (Please refer the block diagram of the test setup and photographs). The AC line are checked to find out the maximum conducted emission. In order to find the maximum emission levels, the relative positions of equipment and all of the interface cables shall be changed according to ANSI C63.10: 2013 on Conducted Emission Test.

The bandwidth of test receiver (R & S ESCI) is set at 9kHz.

The frequency range from 150kHz to 30MHz is checked.

3.7. Power Line Conducted Emission Test Results

PASS. (All emissions not reported below are too low against the prescribed limits.)

5180-5240MHz Band:

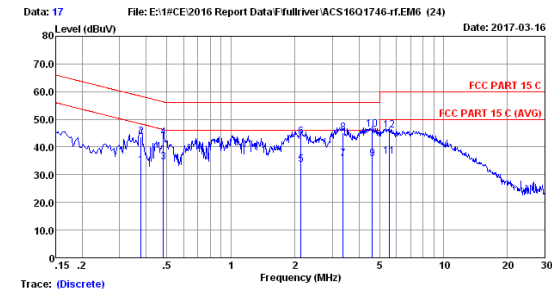

File: E:\1#CE\2016 Report Data\Fullriver\ACS1601746-rLEM6 (24) Date: 2017-03-16

Trace: (Discrete)
 Site no :1# Conduction
 Dis./Lism :2016 ESH2-25 NEUTRAL
 Limit :FCC PART 15 C
 Env./Ins. :22.5°C/53% Engineer :Evan
 EUT :CaptionCall Wireless Router 2
 Power Rating :DC 9V From Adapter Input AC 120V/60Hz
 Test Mode :TX Mode
 M/N:CR2

No	Freq (MHz)	LISN Factor (dB)	Cable Loss (dB)	Reading (dBuV)	Emission Level (dBuV)	Limits (dBuV)	Margin (dB)	Remark
1	0.377	0.15	0.03	33.25	33.43	48.34	14.91	Average
2	0.377	0.15	0.03	43.42	43.60	58.34	14.74	QP
3	0.481	0.15	0.03	34.25	34.43	46.32	11.89	Average
4	0.481	0.15	0.03	43.36	43.54	56.32	12.78	QP
5	2.133	0.20	0.08	33.24	33.52	46.00	12.48	Average
6	2.133	0.20	0.08	43.38	43.66	56.00	12.34	QP
7	3.364	0.22	0.08	35.41	35.71	46.00	10.29	Average
8	3.364	0.22	0.08	44.78	45.08	56.00	10.92	QP
9	4.622	0.26	0.09	35.41	35.76	46.00	10.24	Average
10	4.622	0.26	0.09	46.09	46.44	56.00	9.56	QP
11	5.564	0.29	0.10	36.14	36.53	50.00	13.47	Average
12	5.564	0.29	0.10	45.67	46.06	50.00	13.94	QP

Remarks: 1.Emission Level=LISN Factor+Cable Loss+Reading.
 2.If the average limit is met when using a quasi-peak detector, the EUT shall be deemed to meet both limits and measurement with average detector is unnecessary.

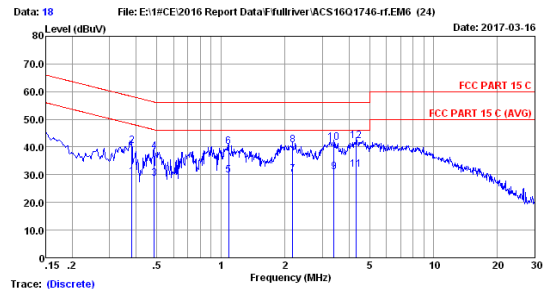

File: E:\1#CE\2016 Report Data\Fullriver\ACS1601746-rLEM6 (24) Date: 2017-03-16

Trace: (Discrete)
 Site no :1# Conduction
 Dis./Lism :2016 ESH2-25 LINE
 Limit :FCC PART 15 C
 Env./Ins. :22.5°C/53% Engineer :Evan
 EUT :CaptionCall Wireless Router 2
 Power Rating :DC 9V From Adapter Input AC 120V/60Hz
 Test Mode :TX Mode
 M/N:CR2

No	Freq (MHz)	LISN Factor (dB)	Cable Loss (dB)	Reading (dBuV)	Emission Level (dBuV)	Limits (dBuV)	Margin (dB)	Remark
1	0.381	0.13	0.03	29.11	29.27	48.25	18.98	Average
2	0.381	0.13	0.03	40.35	40.51	58.25	17.74	QP
3	0.486	0.12	0.03	28.58	28.73	46.23	17.50	Average
4	0.486	0.12	0.03	38.34	38.49	56.23	17.74	QP
5	1.088	0.18	0.07	29.47	29.72	46.00	16.28	Average
6	1.088	0.18	0.07	39.97	40.22	56.00	15.78	QP
7	2.178	0.20	0.08	30.16	30.16	46.00	15.84	Average
8	2.178	0.20	0.08	40.53	40.81	56.00	15.19	QP
9	3.399	0.22	0.08	30.74	31.04	46.00	14.96	Average
10	3.399	0.22	0.08	41.31	41.61	56.00	14.39	QP
11	4.338	0.24	0.09	31.53	31.86	46.00	14.14	Average
12	4.338	0.24	0.09	42.00	42.33	56.00	13.67	QP

Remarks: 1.Emission Level=LISN Factor+Cable Loss+Reading.
 2.If the average limit is met when using a quasi-peak detector, the EUT shall be deemed to meet both limits and measurement with average detector is unnecessary.

5745-5825MHz Band:

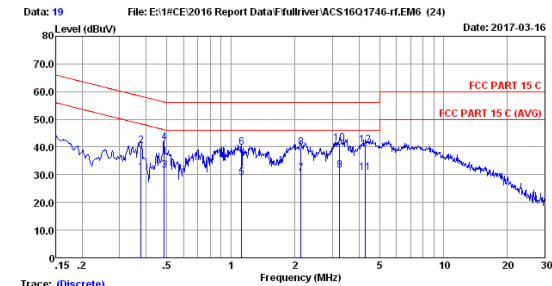

File: E:\1#CE\2016 Report Data\Fullriver\ACS1601746-rLEM6 (24) Date: 2017-03-16

Trace: (Discrete)
 Site no :1# Conduction
 Dis./Lism :2016 ESH2-25 LINE
 Limit :FCC PART 15 C
 Env./Ins. :22.5°C/53% Engineer :Evan
 EUT :CaptionCall Wireless Router 2
 Power Rating :DC 9V From Adapter Input AC 120V/60Hz
 Test Mode :TX Mode
 M/N:CR2

No	Freq (MHz)	LISN Factor (dB)	Cable Loss (dB)	Reading (dBuV)	Emission Level (dBuV)	Limits (dBuV)	Margin (dB)	Remark
1	0.377	0.13	0.03	30.55	30.71	48.34	17.63	Average
2	0.377	0.13	0.03	40.15	40.31	58.34	18.03	QP
3	0.486	0.12	0.03	31.58	31.73	46.23	14.50	Average
4	0.486	0.12	0.03	41.44	41.59	56.23	14.64	QP
5	1.123	0.18	0.07	28.82	29.07	46.00	16.93	Average
6	1.123	0.18	0.07	39.66	39.91	56.00	16.09	QP
7	2.133	0.20	0.08	30.26	30.54	46.00	15.46	Average
8	2.133	0.20	0.08	39.56	39.84	56.00	16.16	QP
9	3.241	0.22	0.08	31.41	31.71	46.00	14.29	Average
10	3.241	0.22	0.08	41.06	41.36	56.00	14.64	QP
11	4.292	0.24	0.09	30.51	30.84	46.00	15.16	Average
12	4.292	0.24	0.09	40.37	40.70	56.00	15.30	QP

Remarks: 1.Emission Level=LISN Factor+Cable Loss+Reading.
 2.If the average limit is met when using a quasi-peak detector, the EUT shall be deemed to meet both limits and measurement with average detector is unnecessary.

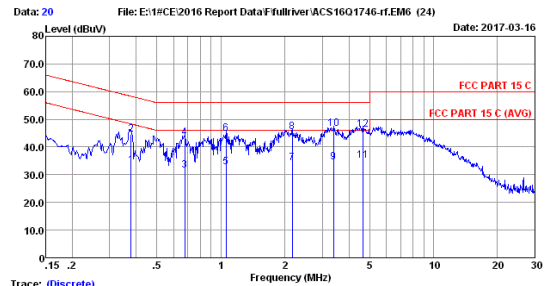

File: E:\1#CE\2016 Report Data\Fullriver\ACS1601746-rLEM6 (24) Date: 2017-03-16

Trace: (Discrete)
 Site no :1# Conduction
 Dis./Lism :2016 ESH2-25 NEUTRAL
 Limit :FCC PART 15 C
 Env./Ins. :22.5°C/53% Engineer :Evan
 EUT :CaptionCall Wireless Router 2
 Power Rating :DC 9V From Adapter Input AC 120V/60Hz
 Test Mode :TX Mode
 M/N:CR2

No	Freq (MHz)	LISN Factor (dB)	Cable Loss (dB)	Reading (dBuV)	Emission Level (dBuV)	Limits (dBuV)	Margin (dB)	Remark
1	0.377	0.15	0.03	33.26	33.44	48.34	14.90	Average
2	0.377	0.15	0.03	44.25	44.43	58.34	13.91	QP
3	0.675	0.15	0.04	31.28	31.47	46.00	14.53	Average
4	0.675	0.15	0.04	43.24	43.43	56.00	12.57	QP
5	1.060	0.17	0.07	32.58	32.82	46.00	13.18	Average
6	1.060	0.17	0.07	44.55	44.79	56.00	11.21	QP
7	2.167	0.20	0.08	33.82	34.10	46.00	11.90	Average
8	2.167	0.20	0.08	45.26	45.54	56.00	10.46	QP
9	3.381	0.22	0.08	34.28	34.58	46.00	11.42	Average
10	3.381	0.22	0.08	46.34	46.64	56.00	9.36	QP
11	4.672	0.27	0.09	34.71	35.07	46.00	10.93	Average
12	4.672	0.27	0.09	46.13	46.49	56.00	9.51	QP

Remarks: 1.Emission Level=LISN Factor+Cable Loss+Reading.
 2.If the average limit is met when using a quasi-peak detector, the EUT shall be deemed to meet both limits and measurement with average detector is unnecessary.

4. RADIATED EMISSION TEST

4.1. Test Equipment

4.1.1. For frequency range 30 MHz ~1000MHz (In 3m Anechoic Chamber)

Item	Equipment	Manufacturer	Model No.	Serial No.	Last Cal.	Cal. Interval
1.	3#Chamber	AUDIX	N/A	N/A	Mar.28,17	1 Year
2.	Spectrum Analyzer	Agilent	N9010A	MY52220804	Oct.15,16	1 Year
3.	EMI Test Receiver	Rohde & Schwarz	ESR7	101547	Apr.24,16	1 Year
4.	Amplifier	HP	8447D	2648A04738	Apr.24,16	1 Year
5.	Tri-log-Broadband Antenna	SCHWARZBECK	VULB 9168	9168-710	Jul.20,16	1 Year
6.	RF Cable	MIYAZAKI	CFD400NL-LW	No.3	Sep.26.16	1 Year
7.	Coaxial Switch	Anritsu	MP59B	6201397222	Apr.23,16	1 Year
8.	Attenuator	EMCI	EMCI-N-6-06	AT-N0639	Sep.26.16	1 Year
9.	Test Software	AUDIX	e3	6.2009-5-21a(n)	N/A	N/A

Note: N/A means Not applicable.

4.1.2. For frequency range 1GHz~40GHz (In 3m Anechoic Chamber)

Item	Equipment	Manufacturer	Model No.	Serial No.	Last Cal.	Cal. Interval
1.	3#Chamber	AUDIX	N/A	N/A	May.21,16	1 Year
2.	Spectrum Analyzer	Agilent	N9010A	MY52220804	Oct.15,16	1 Year
3.	Horn Antenna	ETC	MCTD 1209	DRH15F03007	Apr.11,16	1 Year
4.	Amplifier	Agilent	83017A	MY53270084	May.17,16	1 Year
5.	RF Cable	Hubersuhner	SUCOFLEX106	505238/6	Apr.24,16	1 Year
6.	Horn Antenna	ETS	3116	00060089	Nov.16,16	1 Year
7.	Test Software	AUDIX	e3	6.2009-5-21a(n)	N/A	N/A

Note: N/A means Not applicable.

4.2. Block Diagram of Test Setup

For frequency range 30MHz-1000MHz

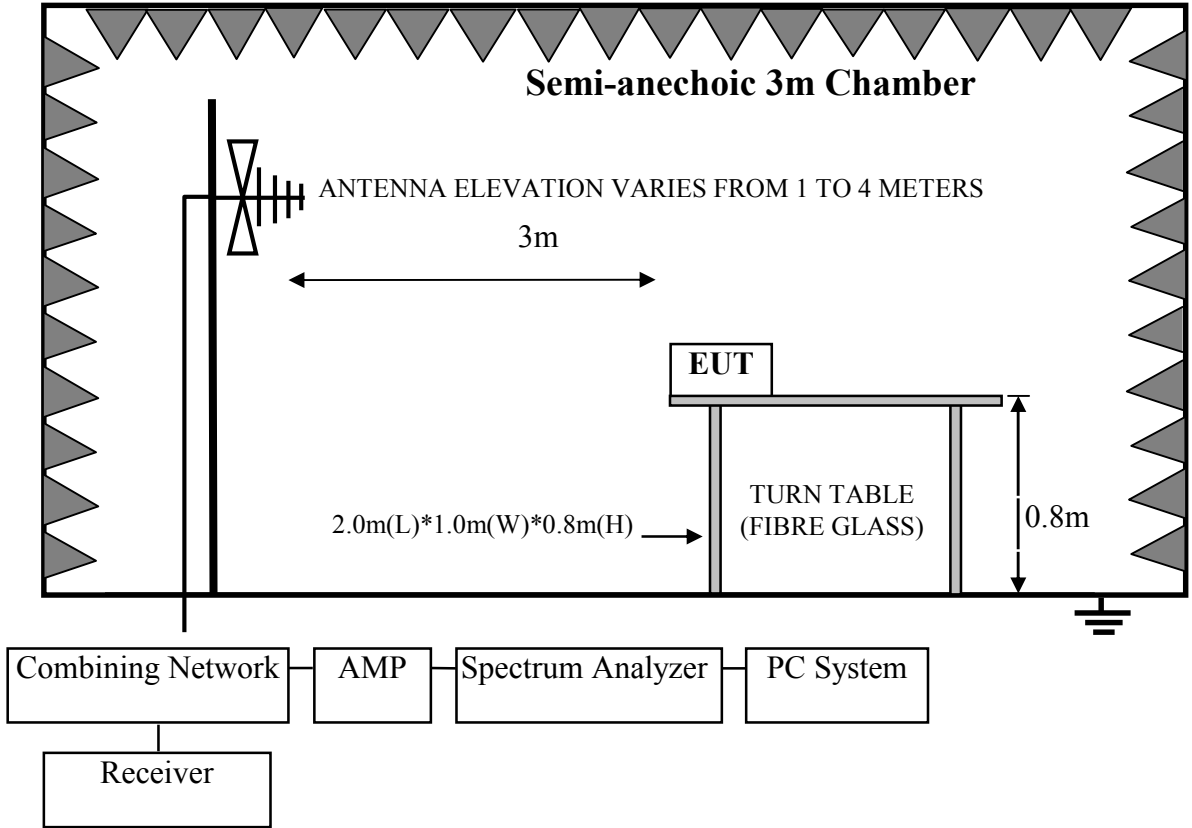

For frequency range 1GHz-40GHz

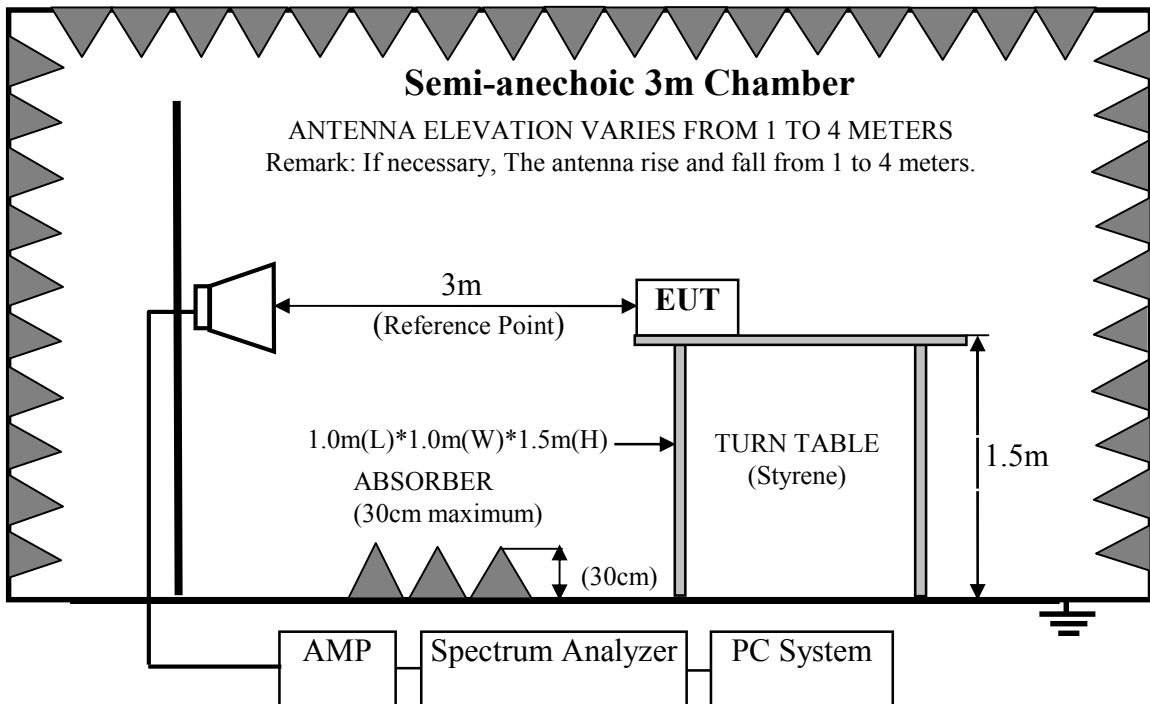

4.3. Radiated Emission Limit

For transmitters operating in the 5.15-5.25 GHz; 5.725-5.850GHz band: all emissions outside of those band shall not exceed an EIRP of -27 dBm/MHz. Unwanted emissions below 1 GHz and those emissions appearing within 15.205 restricted frequency bands must comply with the general field strength limits set forth in Section 15.209

4.3.1. 15.209 limits

FREQUENCY MHz	DISTANCE Meters	FIELD STRENGTHS LIMIT	
		µV/m	dB(µV)/m
30 ~ 88	3	100	40.0
88 ~ 216	3	150	43.5
216 ~ 960	3	200	46.0
960 ~ 1000	3	500	54.0
Above 1000	3	74.0 dB(µV)/m (Peak) 54.0 dB(µV)/m (Average)	

- Remarks :
- (1) Emission level dBµV = 20 log Emission level µV/m
 - (2) The smaller limit shall apply at the cross point between two frequency bands.
 - (3) Distance is the distance in meters between the measuring instrument, antenna and the closest point of any part of the device or system.

4.3.2. 15.205 Restricted bands of operation

MHz	MHz	MHz	GHz
0.090 - 0.110	16.42 - 16.423	399.9 - 410	4.5 - 5.15
0.495 - 0.505	16.69475 - 16.69525	608 - 614	5.35 - 5.46
2.1735 - 2.1905	16.80425 - 16.80475	960 - 1240	7.25 - 7.75
4.125 - 4.128	25.5 - 25.67	1300 - 1427	8.025 - 8.5
4.17725 - 4.17775	37.5 - 38.25	1435 - 1626.5	9.0 - 9.2
4.20725 - 4.20775	73 - 74.6	1645.5 - 1646.5	9.3 - 9.5
6.215 - 6.218	74.8 - 75.2	1660 - 1710	10.6 - 12.7
6.26775 - 6.26825	108 - 121.94	1718.8 - 1722.2	13.25 - 13.4
6.31175 - 6.31225	123 - 138	2200 - 2300	14.47 - 14.5
8.291 - 8.294	149.9 - 150.05	2310 - 2390	15.35 - 16.2
8.362 - 8.366	156.52475 - 156.52525	2483.5 - 2500	17.7 - 21.4
8.37625 - 8.38675	156.7 - 156.9	2690 - 2900	22.01 - 23.12
8.41425 - 8.41475	162.0125 - 167.17	3260 - 3267	23.6 - 24.0
12.29 - 12.293	167.72 - 173.2	3332 - 3339	31.2 - 31.8
12.51975 - 12.52025	240 - 285	3345.8 - 3358	36.43 - 36.5
12.57675 - 12.57725	322 - 335.4	3600 - 4400	(²)

4.4. EUT Configuration on Test

The following equipment are installed on Power Line Conducted Emission Test to meet the commission requirement and operating regulations in a manner which tends to maximize its emission characteristics in a normal application.

4.4.1. CaptionCall Wireless Router 2 (EUT)

Model No.: CR2

Serial No.: N/A

4.4.2. Support Equipment: As Tested Supporting System Details, in Section 2.2.

4.5. Operating Condition of EUT

- 4.5.1. Setup the EUT and simulator as shown as Section 4.2.
- 4.5.2. Turn on the power of all equipments.
- 4.5.3. Let EUT work in Tx mode.

4.6. Test Procedure

EUT and its simulators are placed on a turn table, which is 0.8 meter high above ground for frequency 30MHz~1000MHz, 1.5 meter high above ground for frequency above 1GHz and put the absorbing with 2.4m(L)*2.4m(W)*0.3m(H) on the ground . The turn table can rotate 360 degrees to determine the position of the maximum emission level. Power on the EUT and let it working in test mode, then test it. EUT is set 3 meters away from the receiving antenna, which is mounted on a antenna tower. The antenna can be moved up and down between 1 meter and 4 meters to find out the maximum emission level. Broadband antenna (calibrated bilog antenna) is used as receiving antenna for frequency 30MHz~1000MHz, and the Horn antenna is used as receiving antenna for frequency above 1GHz. Both horizontal and vertical polarization of the antenna is set on Test. In order to find the maximum emission levels, all of the interface cables must be manipulated according to ANSI C63.10-2013 on radiated emission Test.

For emissions below 1GHz and those emissions appearing within 15.205 restricted frequency bands use below procedure:

The bandwidth of the EMI test receiver (R&S ESR7) is set at 120kHz for frequency range from 30MHz to 1000 MHz.

The bandwidth of the Spectrum's VBW is set at 1MHz and RBW is set at 1MHz for peak emissions measurement above 1GHz and 1MHz RBW, 10Hz VBW for average emissions measure above 1GHz

For the emissions above 1GHz and not appearing within 15.205 restricted frequency bands use below procedure:

- (1). The maximum emission at 3m distance was measured and recorded with receive antenna in both vertical and horizontal by rotating the turntable and by lowering the receive antenna.
- (2). The EUT was then removed and replaced with a substitution antenna in the same position and the substitution antenna must have the same polarization with the receive antenna.
- (3). A signal which have the same frequency obtained in step 2 was fed to the substitution, the receive antenna was raised and lowered to obtain a maximum reading at the test receiver, the level of the signal generator was adjusted until the measured field strength level in step 2 was obtained, recorded the level of the signal generator.
- (4). Repeated step 4 with both antenna polarizations
- (5). The spurious emissions is equal to the power supplied by the signal generator and corrections due to the gain of the substitution antenna and the cable loss between the signal generator and the substitution antenna. or use procedure (6).
- (6). Per KDB789033 clause H 2)d). if the test distance is 3m, the $EIRP(dBm) = E(dB\mu V/m) - 95.2$
Get the result of all unwanted emission outside the restricted band is less than the -27dBm/MHz.

We had checked frequency range that is 30MHz to 10th harmonic (40GHz) and no any emissions were found from 18GHz to 40GHz, so the radiated emission from 18GHz to 40GHz were not record.

**5180-5240MHz Band:
Frequency: 30MHz~1GHz**

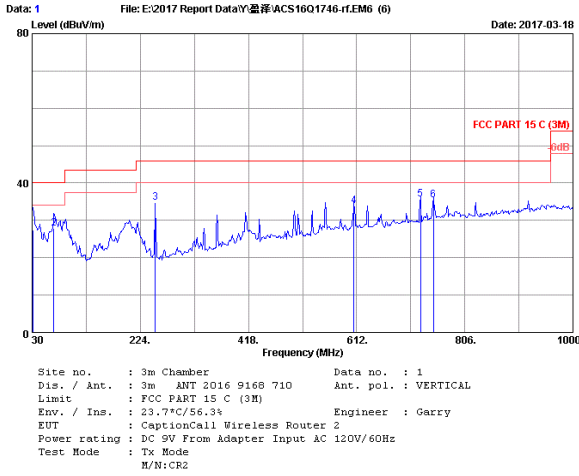

No.	Freq. (MHz)	Ant. Factor (dB/m)	Cable Loss (dB)	Reading (dBuV)	Emission Level (dBuV/m)	Limits (dBuV/m)	Margin (dB)	Remark
1	31.020	19.24	0.60	7.50	27.34	40.00	12.66	QP
2	68.800	18.03	1.03	8.72	27.78	40.00	12.22	QP
3	251.160	18.30	1.51	15.00	34.81	46.00	11.19	QP
4	607.150	26.16	3.15	4.58	33.89	46.00	12.11	QP
5	726.480	27.40	3.65	4.59	35.64	46.00	10.36	QP
6	749.740	27.83	3.76	3.73	35.32	46.00	10.68	QP

Remarks: 1. Emission Level= Antenna Factor + Cable Loss + Reading.
 2. The emission levels that are 20dB below the official limit are not reported.

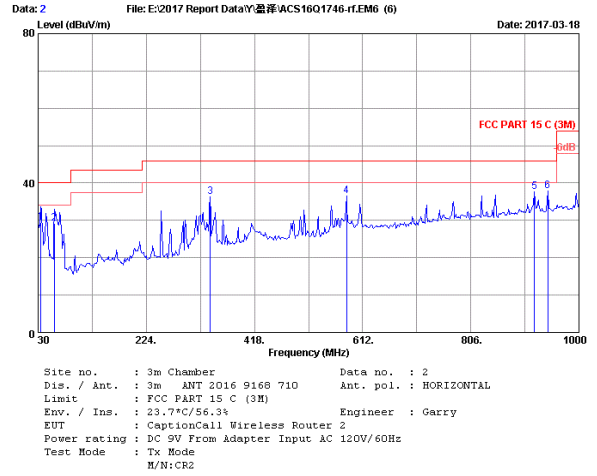

No.	Freq. (MHz)	Ant. Factor (dB/m)	Cable Loss (dB)	Reading (dBuV)	Emission Level (dBuV/m)	Limits (dBuV/m)	Margin (dB)	Remark
1	34.150	19.38	0.63	9.50	29.49	40.00	10.51	QP
2	59.100	19.78	0.91	8.40	29.09	40.00	10.91	QP
3	338.460	20.89	2.16	13.35	36.40	46.00	9.60	QP
4	582.900	25.47	3.06	7.91	36.44	46.00	9.56	QP
5	920.460	29.65	4.39	3.70	37.74	46.00	8.26	QP
6	943.740	29.88	4.45	3.48	37.81	46.00	8.19	QP

Remarks: 1. Emission Level= Antenna Factor + Cable Loss + Reading.
 2. The emission levels that are 20dB below the official limit are not reported.

Frequency: 1GHz~18GHz

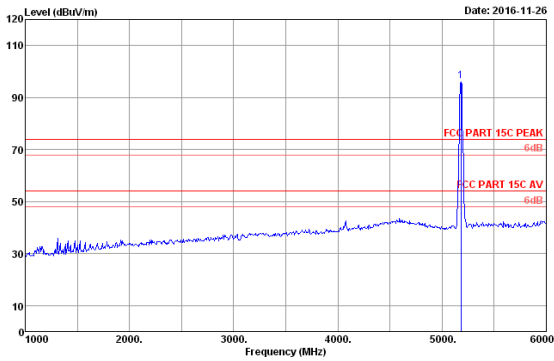

Site no. : 3m Chamber Data no. : 1
 Dis. / Ant. : 3m 2016 MCTD1209 3007 Ant. pol. : HORIZONTAL
 Limit : FCC PART 15C PEAK Pre : 101.2kPa
 Env. / Ins. : 23.1°C/54.9% Engineer : Lynn
 EUT : CaptionCall Wireless Router 2
 Power rating : DC 9V From Adapter Input AC 120V/60Hz
 Test Mode : IEEE802.11a 5180MHz Tx Mode
 N/N:CR2

No.	Freq. (MHz)	Ant. Factor (dB/m)	Cable Loss (dB)	Reading (dBuV)	AMP factor (dB)	Emission Level (dBuV/m)	Limits (dBuV/m)	Margin (dB)	Remark
1	5180.00	32.40	11.91	87.56	35.62	96.25	74.00	-22.25	Peak

Remarks: 1. Emission Level= Antenna Factor + Cable Loss + Reading -Ant Factor
 2. The emission levels that are 20dB below the official limit are not reported.

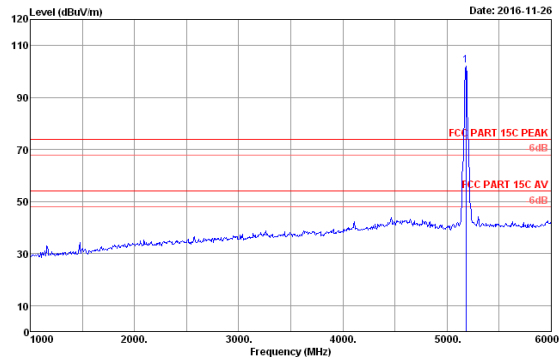

Site no. : 3m Chamber Data no. : 2
 Dis. / Ant. : 3m 2016 MCTD1209 3007 Ant. pol. : VERTICAL
 Limit : FCC PART 15C PEAK Pre : 101.2kPa
 Env. / Ins. : 23.1°C/54.9% Engineer : Lynn
 EUT : CaptionCall Wireless Router 2
 Power rating : DC 9V From Adapter Input AC 120V/60Hz
 Test Mode : IEEE802.11a 5180MHz Tx Mode
 N/N:CR2

No.	Freq. (MHz)	Ant. Factor (dB/m)	Cable Loss (dB)	Reading (dBuV)	AMP factor (dB)	Emission Level (dBuV/m)	Limits (dBuV/m)	Margin (dB)	Remark
1	5180.00	32.40	11.91	93.67	35.62	102.36	74.00	-28.36	Peak

Remarks: 1. Emission Level= Antenna Factor + Cable Loss + Reading -Ant Factor
 2. The emission levels that are 20dB below the official limit are not reported.

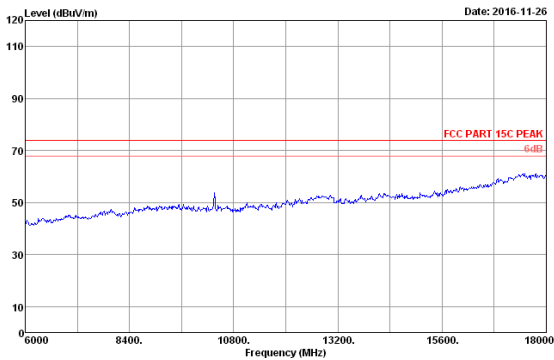

Site no. : 3m Chamber Data no. : 3
 Dis. / Ant. : 3m 2016 MCTD1209 3007 Ant. pol. : VERTICAL
 Limit : FCC PART 15C PEAK Pre : 101.2kPa
 Env. / Ins. : 23.1°C/54.9% Engineer : Lynn
 EUT : CaptionCall Wireless Router 2
 Power rating : DC 9V From Adapter Input AC 120V/60Hz
 Test Mode : IEEE802.11a 5180MHz Tx Mode
 N/N:CR2

No.	Freq. (MHz)	Ant. Factor (dB/m)	Cable Loss (dB)	Reading (dBuV)	AMP factor (dB)	Emission Level (dBuV/m)	Limits (dBuV/m)	Margin (dB)	Remark
1	10360.00	38.26	13.34	35.01	36.30	50.31	54.00	3.69	Average
2	10360.00	38.26	13.34	46.39	36.30	61.69	74.00	12.31	Peak

Remarks: 1. Emission Level= Antenna Factor + Cable Loss + Reading -Ant Factor
 2. The emission levels that are 20dB below the official limit are not reported.

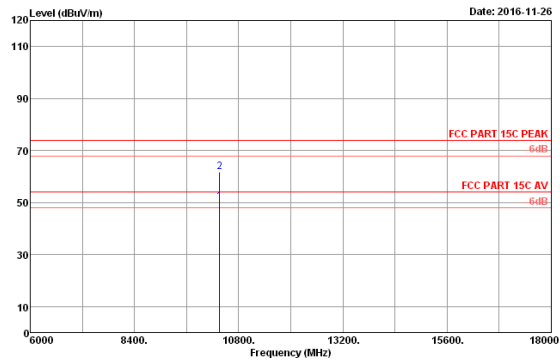

Site no. : 3m Chamber Data no. : 4
 Dis. / Ant. : 3m 2016 MCTD1209 3007 Ant. pol. : VERTICAL
 Limit : FCC PART 15C PEAK Pre : 101.2kPa
 Env. / Ins. : 23.1°C/54.9% Engineer : Lynn
 EUT : CaptionCall Wireless Router 2
 Power rating : DC 9V From Adapter Input AC 120V/60Hz
 Test Mode : IEEE802.11a 5180MHz Tx Mode
 N/N:CR2

No.	Freq. (MHz)	Ant. Factor (dB/m)	Cable Loss (dB)	Reading (dBuV)	AMP factor (dB)	Emission Level (dBuV/m)	Limits (dBuV/m)	Margin (dB)	Remark
1	10360.00	38.26	13.34	35.01	36.30	50.31	54.00	3.69	Average
2	10360.00	38.26	13.34	46.39	36.30	61.69	74.00	12.31	Peak

Remarks: 1. Emission Level= Antenna Factor + Cable Loss + Reading -Ant Factor
 2. The emission levels that are 20dB below the official limit are not reported.

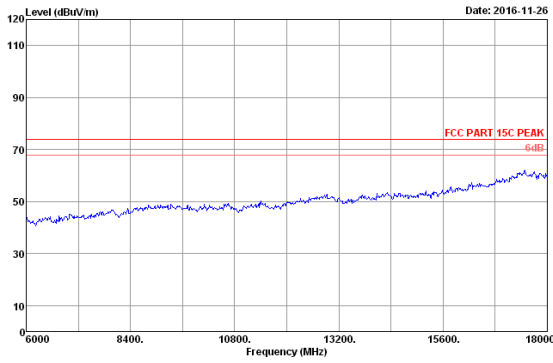

Date: 2016-11-26
 Site no. : 3m Chamber Data no. : 5
 Dis. / Ant. : 3m 2016 MCTD1209 3007 Ant. pol. : HORIZONTAL
 Limit : FCC PART 15C PEAK Pre : 101.2kPa
 Env. / Ins. : 23.1°C/54.9% Engineer : Lynn
 EUT : CaptionCall Wireless Router 2
 Power rating : DC 9V From Adapter Input AC 120V/60Hz
 Test Mode : IEEE802.11a 5180MHz Tx Mode
 M/N:CR2

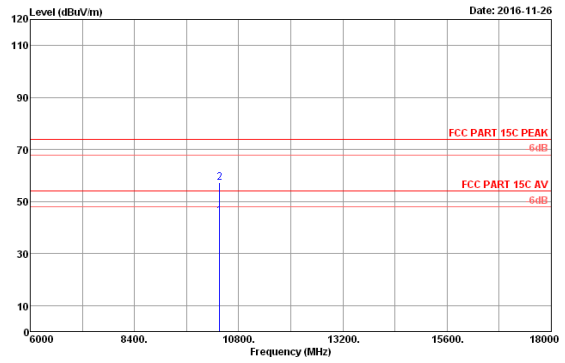

Date: 2016-11-26
 Site no. : 3m Chamber Data no. : 6
 Dis. / Ant. : 3m 2016 MCTD1209 3007 Ant. pol. : HORIZONTAL
 Limit : FCC PART 15C PEAK Pre : 101.2kPa
 Env. / Ins. : 23.1°C/54.9% Engineer : Lynn
 EUT : CaptionCall Wireless Router 2
 Power rating : DC 9V From Adapter Input AC 120V/60Hz
 Test Mode : IEEE802.11a 5180MHz Tx Mode
 M/N:CR2

No.	Freq. (MHz)	Ant. Factor (dB/m)	Cable Loss (dB)	Reading (dBuV)	AMP factor (dB)	Emission Level (dBuV/m)	Limits (dBuV/m)	Margin (dB)	Remark
1	10360.00	38.26	13.34	29.30	36.30	44.60	54.00	9.40	Average
2	10360.00	38.26	13.34	41.82	36.30	57.12	74.00	16.88	Peak

Remarks: 1. Emission Level= Antenna Factor + Cable Loss + Reading - Amp Factor
 2. The emission levels that are 20dB below the official limit are not reported.

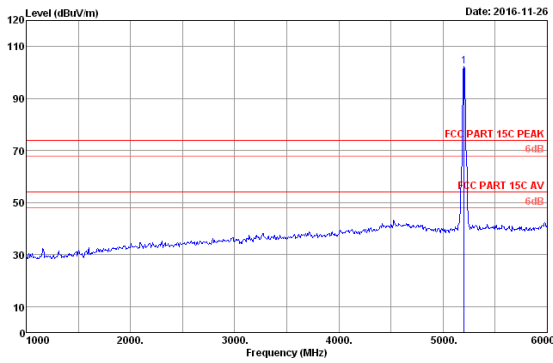

Date: 2016-11-26
 Site no. : 3m Chamber Data no. : 11
 Dis. / Ant. : 3m 2016 MCTD1209 3007 Ant. pol. : VERTICAL
 Limit : FCC PART 15C PEAK Pre : 101.2kPa
 Env. / Ins. : 23.1°C/54.9% Engineer : Lynn
 EUT : CaptionCall Wireless Router 2
 Power rating : DC 9V From Adapter Input AC 120V/60Hz
 Test Mode : IEEE802.11a 5200MHz Tx Mode
 M/N:CR2

No.	Freq. (MHz)	Ant. Factor (dB/m)	Cable Loss (dB)	Reading (dBuV)	AMP factor (dB)	Emission Level (dBuV/m)	Limits (dBuV/m)	Margin (dB)	Remark
1	5200.00	32.40	11.91	93.57	35.61	102.27	74.00	-28.27	Peak

Remarks: 1. Emission Level= Antenna Factor + Cable Loss + Reading - Amp Factor
 2. The emission levels that are 20dB below the official limit are not reported.

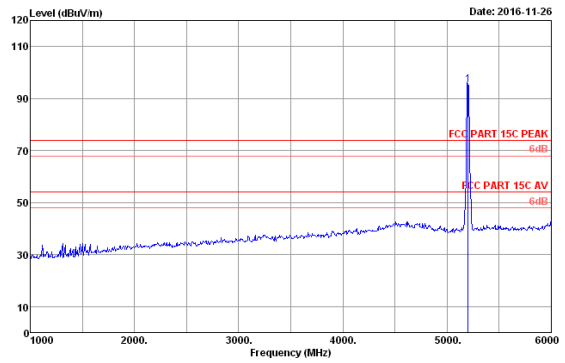

Date: 2016-11-26
 Site no. : 3m Chamber Data no. : 12
 Dis. / Ant. : 3m 2016 MCTD1209 3007 Ant. pol. : HORIZONTAL
 Limit : FCC PART 15C PEAK Pre : 101.2kPa
 Env. / Ins. : 23.1°C/54.9% Engineer : Lynn
 EUT : CaptionCall Wireless Router 2
 Power rating : DC 9V From Adapter Input AC 120V/60Hz
 Test Mode : IEEE802.11a 5200MHz Tx Mode
 M/N:CR2

No.	Freq. (MHz)	Ant. Factor (dB/m)	Cable Loss (dB)	Reading (dBuV)	AMP factor (dB)	Emission Level (dBuV/m)	Limits (dBuV/m)	Margin (dB)	Remark
1	5200.00	32.40	11.91	86.78	35.61	95.48	74.00	-21.48	Peak

Remarks: 1. Emission Level= Antenna Factor + Cable Loss + Reading - Amp Factor
 2. The emission levels that are 20dB below the official limit are not reported.

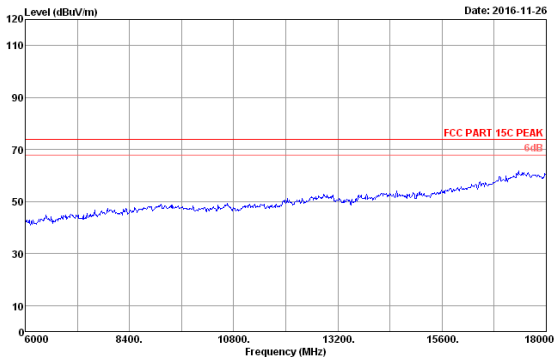

Site no. : 3m Chamber Data no. : 13
 Dis. / Ant. : 3m 2016 MCTD1209 3007 Ant. pol. : HORIZONTAL
 Limit : FCC PART 15C PEAK Pre : 101.2kPa
 Env. / Ins. : 23.14C/54.9W Engineer : Lynn
 EUT : CaptionCall Wireless Router 2
 Power rating : DC 9V From Adapter Input AC 120V/60Hz
 Test Mode : IEEE802.11a 5200MHz Tx Mode
 M/N:CR2

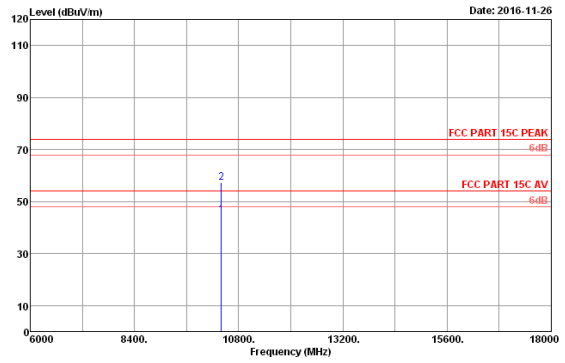

Site no. : 3m Chamber Data no. : 14
 Dis. / Ant. : 3m 2016 MCTD1209 3007 Ant. pol. : HORIZONTAL
 Limit : FCC PART 15C PEAK Pre : 101.2kPa
 Env. / Ins. : 23.14C/54.9W Engineer : Lynn
 EUT : CaptionCall Wireless Router 2
 Power rating : DC 9V From Adapter Input AC 120V/60Hz
 Test Mode : IEEE802.11a 5200MHz Tx Mode
 M/N:CR2

No.	Freq. (MHz)	Ant. Factor (dB/m)	Cable Loss (dB)	Reading (dBuV)	AMP factor (dB)	Emission Level (dBuV/m)	Limits (dBuV/m)	Margin (dB)	Remark
1	10400.00	38.30	13.35	29.55	36.31	44.89	54.00	9.11	Average
2	10400.00	38.30	13.35	41.86	36.31	57.20	74.00	16.80	Peak

Remarks: 1. Emission Level= Antenna Factor + Cable Loss + Reading - Amp Factor
 2. The emission levels that are 20dB below the official limit are not reported.

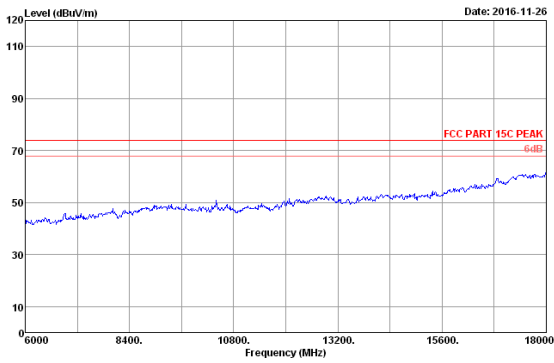

Site no. : 3m Chamber Data no. : 15
 Dis. / Ant. : 3m 2016 MCTD1209 3007 Ant. pol. : VERTICAL
 Limit : FCC PART 15C PEAK Pre : 101.2kPa
 Env. / Ins. : 23.14C/54.9W Engineer : Lynn
 EUT : CaptionCall Wireless Router 2
 Power rating : DC 9V From Adapter Input AC 120V/60Hz
 Test Mode : IEEE802.11a 5200MHz Tx Mode
 M/N:CR2

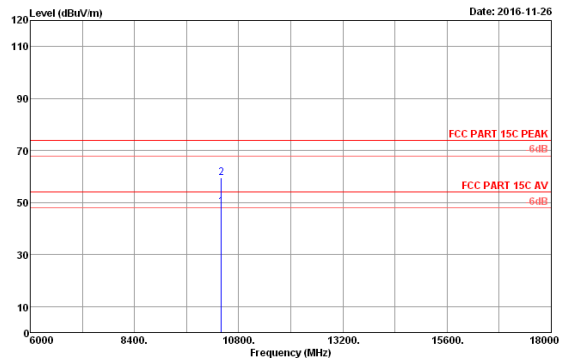

Site no. : 3m Chamber Data no. : 16
 Dis. / Ant. : 3m 2016 MCTD1209 3007 Ant. pol. : VERTICAL
 Limit : FCC PART 15C PEAK Pre : 101.2kPa
 Env. / Ins. : 23.14C/54.9W Engineer : Lynn
 EUT : CaptionCall Wireless Router 2
 Power rating : DC 9V From Adapter Input AC 120V/60Hz
 Test Mode : IEEE802.11a 5200MHz Tx Mode
 M/N:CR2

No.	Freq. (MHz)	Ant. Factor (dB/m)	Cable Loss (dB)	Reading (dBuV)	AMP factor (dB)	Emission Level (dBuV/m)	Limits (dBuV/m)	Margin (dB)	Remark
1	10400.00	38.30	13.35	33.06	36.31	48.40	54.00	5.60	Average
2	10400.00	38.30	13.35	44.03	36.31	59.37	74.00	14.63	Peak

Remarks: 1. Emission Level= Antenna Factor + Cable Loss + Reading - Amp Factor
 2. The emission levels that are 20dB below the official limit are not reported.

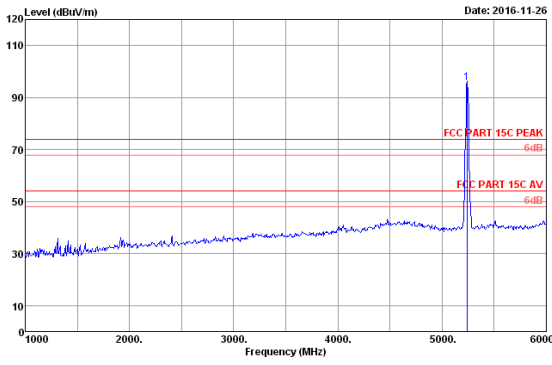

Date: 2016-11-26
 Site no. : 3m Chamber Data no. : 17
 Dis. / Ant. : 3m 2016 MCTD1209 3007 Ant. pol. : HORIZONTAL
 Limit : FCC PART 15C PEAK Pre : 101.2kPa
 Env. / Ins. : 23.14C/54.9W Engineer : Lynn
 EUT : CaptionCall Wireless Router 2
 Power rating : DC 9V From Adapter Input AC 120V/60Hz
 Test Mode : IEEE802.11a 5240MHz Tx Mode
 M/N:CR2

No.	Freq. (MHz)	Ant. Factor (dB/m)	Cable Loss (dB)	Reading (dBuV)	AMP factor (dB)	Emission Level (dBuV/m)	Limits (dBuV/m)	Margin (dB)	Remark
1	5240.00	32.40	11.91	86.95	35.59	95.87	74.00	-21.67	Peak

Remarks: 1. Emission Level= Antenna Factor + Cable Loss + Reading - Amp Factor
 2. The emission levels that are 20dB below the official limit are not reported.

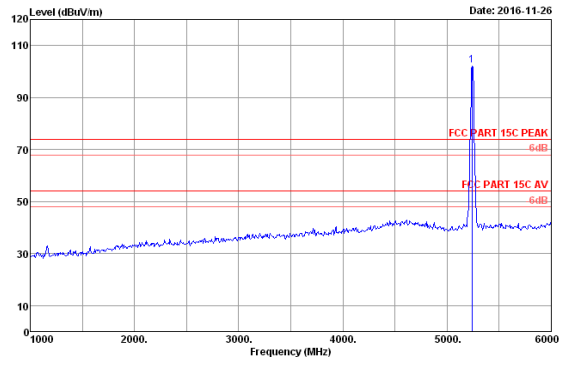

Date: 2016-11-26
 Site no. : 3m Chamber Data no. : 18
 Dis. / Ant. : 3m 2016 MCTD1209 3007 Ant. pol. : VERTICAL
 Limit : FCC PART 15C PEAK Pre : 101.2kPa
 Env. / Ins. : 23.14C/54.9W Engineer : Lynn
 EUT : CaptionCall Wireless Router 2
 Power rating : DC 9V From Adapter Input AC 120V/60Hz
 Test Mode : IEEE802.11a 5240MHz Tx Mode
 M/N:CR2

No.	Freq. (MHz)	Ant. Factor (dB/m)	Cable Loss (dB)	Reading (dBuV)	AMP factor (dB)	Emission Level (dBuV/m)	Limits (dBuV/m)	Margin (dB)	Remark
1	5240.00	32.40	11.91	93.82	35.59	102.54	74.00	-28.54	Peak

Remarks: 1. Emission Level= Antenna Factor + Cable Loss + Reading - Amp Factor
 2. The emission levels that are 20dB below the official limit are not reported.

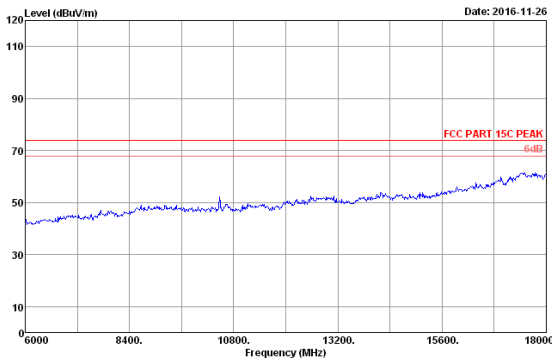

Date: 2016-11-26
 Site no. : 3m Chamber Data no. : 19
 Dis. / Ant. : 3m 2016 MCTD1209 3007 Ant. pol. : VERTICAL
 Limit : FCC PART 15C PEAK Pre : 101.2kPa
 Env. / Ins. : 23.14C/54.9W Engineer : Lynn
 EUT : CaptionCall Wireless Router 2
 Power rating : DC 9V From Adapter Input AC 120V/60Hz
 Test Mode : IEEE802.11a 5240MHz Tx Mode
 M/N:CR2

No.	Freq. (MHz)	Ant. Factor (dB/m)	Cable Loss (dB)	Reading (dBuV)	AMP factor (dB)	Emission Level (dBuV/m)	Limits (dBuV/m)	Margin (dB)	Remark
1	10480.00	38.38	13.37	33.82	36.32	49.25	54.00	4.75	Average
2	10480.00	38.38	13.37	44.84	36.32	60.27	74.00	13.73	Peak

Remarks: 1. Emission Level= Antenna Factor + Cable Loss + Reading - Amp Factor
 2. The emission levels that are 20dB below the official limit are not reported.

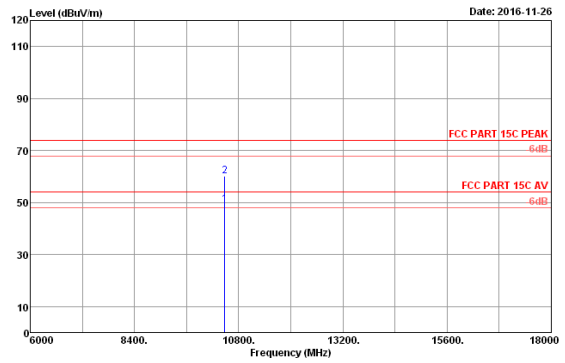

Date: 2016-11-26
 Site no. : 3m Chamber Data no. : 20
 Dis. / Ant. : 3m 2016 MCTD1209 3007 Ant. pol. : VERTICAL
 Limit : FCC PART 15C PEAK Pre : 101.2kPa
 Env. / Ins. : 23.14C/54.9W Engineer : Lynn
 EUT : CaptionCall Wireless Router 2
 Power rating : DC 9V From Adapter Input AC 120V/60Hz
 Test Mode : IEEE802.11a 5240MHz Tx Mode
 M/N:CR2

No.	Freq. (MHz)	Ant. Factor (dB/m)	Cable Loss (dB)	Reading (dBuV)	AMP factor (dB)	Emission Level (dBuV/m)	Limits (dBuV/m)	Margin (dB)	Remark
1	10480.00	38.38	13.37	33.82	36.32	49.25	54.00	4.75	Average
2	10480.00	38.38	13.37	44.84	36.32	60.27	74.00	13.73	Peak

Remarks: 1. Emission Level= Antenna Factor + Cable Loss + Reading - Amp Factor
 2. The emission levels that are 20dB below the official limit are not reported.

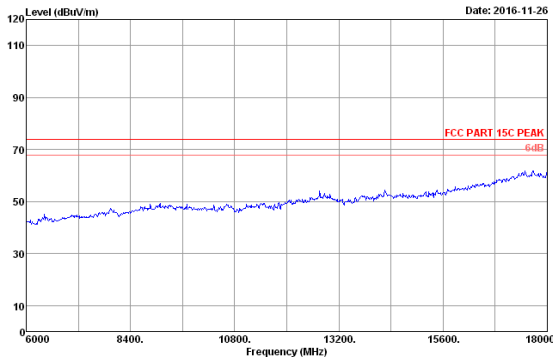

Site no. : 3m Chamber Data no. : 21
 Dis. / Ant. : 3m 2016 MCD1209 3007 Ant. pol. : HORIZONTAL
 Limit : FCC PART 15C PEAK Pre : 101.2kPa
 Env. / Ins. : 23.1°C/54.9% Engineer : Lynn
 EUT : CaptionCall Wireless Router 2
 Power rating : DC 9V From Adapter Input AC 120V/60Hz
 Test Mode : IEEE802.11a 5240MHz Tx Mode
 M/N:CR2

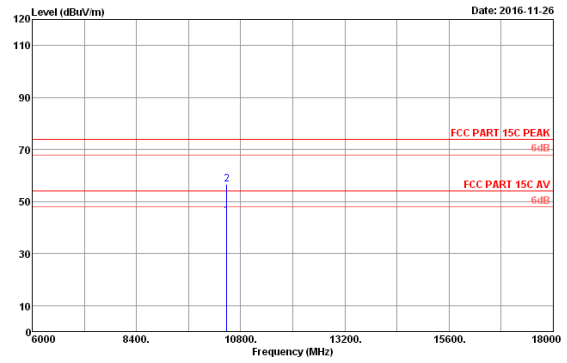

Site no. : 3m Chamber Data no. : 22
 Dis. / Ant. : 3m 2016 MCD1209 3007 Ant. pol. : HORIZONTAL
 Limit : FCC PART 15C PEAK Pre : 101.2kPa
 Env. / Ins. : 23.1°C/54.9% Engineer : Lynn
 EUT : CaptionCall Wireless Router 2
 Power rating : DC 9V From Adapter Input AC 120V/60Hz
 Test Mode : IEEE802.11a 5240MHz Tx Mode
 M/N:CR2

No.	Freq. (MHz)	Ant. Factor (dB/m)	Cable Loss (dB)	Reading (dBuV)	AMP factor (dB)	Emission Level (dBuV/m)	Limits (dBuV/m)	Margin (dB)	Remark
1	10480.00	38.38	13.37	29.09	36.32	44.52	54.00	9.48	Average
2	10480.00	38.38	13.37	41.29	36.32	56.72	74.00	17.28	Peak

Remarks: 1. Emission Level= Antenna Factor + Cable Loss + Reading -Ant Factor
 2. The emission levels that are 20dB below the official limit are not reported.

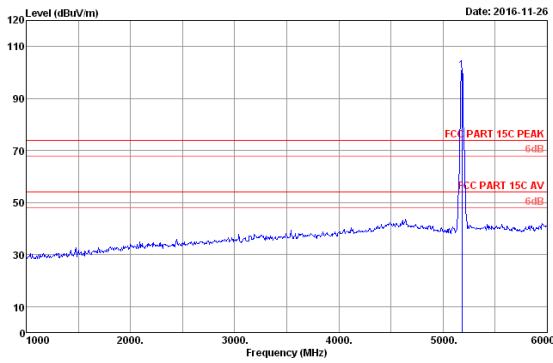

Site no. : 3m Chamber Data no. : 27
 Dis. / Ant. : 3m 2016 MCD1209 3007 Ant. pol. : VERTICAL
 Limit : FCC PART 15C PEAK Pre : 101.2kPa
 Env. / Ins. : 23.1°C/54.9% Engineer : Lynn
 EUT : CaptionCall Wireless Router 2
 Power rating : DC 9V From Adapter Input AC 120V/60Hz
 Test Mode : IEEE802.11n HT20 5180MHz Tx Mode
 M/N:CR2

No.	Freq. (MHz)	Ant. Factor (dB/m)	Cable Loss (dB)	Reading (dBuV)	AMP factor (dB)	Emission Level (dBuV/m)	Limits (dBuV/m)	Margin (dB)	Remark
1	5180.00	32.40	11.91	92.24	35.62	100.93	74.00	-26.93	Peak

Remarks: 1. Emission Level= Antenna Factor + Cable Loss + Reading -Ant Factor
 2. The emission levels that are 20dB below the official limit are not reported.

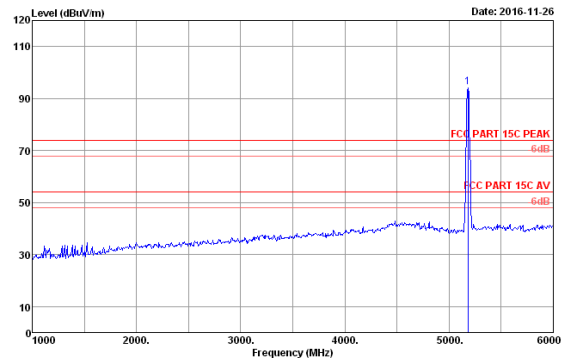

Site no. : 3m Chamber Data no. : 28
 Dis. / Ant. : 3m 2016 MCD1209 3007 Ant. pol. : HORIZONTAL
 Limit : FCC PART 15C PEAK Pre : 101.2kPa
 Env. / Ins. : 23.1°C/54.9% Engineer : Lynn
 EUT : CaptionCall Wireless Router 2
 Power rating : DC 9V From Adapter Input AC 120V/60Hz
 Test Mode : IEEE802.11n HT20 5180MHz Tx Mode
 M/N:CR2

No.	Freq. (MHz)	Ant. Factor (dB/m)	Cable Loss (dB)	Reading (dBuV)	AMP factor (dB)	Emission Level (dBuV/m)	Limits (dBuV/m)	Margin (dB)	Remark
1	5180.00	32.40	11.91	85.81	35.62	94.50	74.00	-20.50	Peak

Remarks: 1. Emission Level= Antenna Factor + Cable Loss + Reading -Ant Factor
 2. The emission levels that are 20dB below the official limit are not reported.

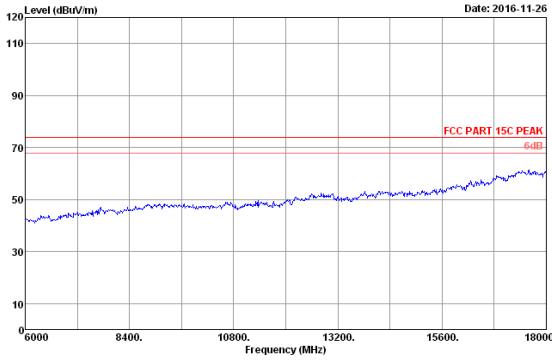

Site no. : 3m Chamber Data no. : 29
 Dis. / Ant. : 3m 2016 MCTD1209 3007 Ant. pol. : HORIZONTAL
 Limit : FCC PART 15C PEAK Pre : 101.2kPa
 Env. / Ins. : 23.14C/54.9W Engineer : Lynn
 EUT : CaptionCall Wireless Router 2
 Power rating : DC 9V From Adapter Input AC 120V/60Hz
 Test Mode : IEEE802.11n HT20 5180MHz Tx Mode
 M/N:CR2

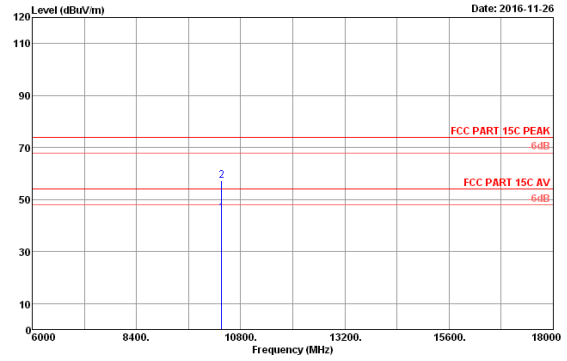

Site no. : 3m Chamber Data no. : 30
 Dis. / Ant. : 3m 2016 MCTD1209 3007 Ant. pol. : HORIZONTAL
 Limit : FCC PART 15C PEAK Pre : 101.2kPa
 Env. / Ins. : 23.14C/54.9W Engineer : Lynn
 EUT : CaptionCall Wireless Router 2
 Power rating : DC 9V From Adapter Input AC 120V/60Hz
 Test Mode : IEEE802.11n HT20 5180MHz Tx Mode
 M/N:CR2

No.	Freq. (MHz)	Ant. Factor (dB/m)	Cable Loss (dB)	Reading (dBuV)	AMP factor (dB)	Emission Level (dBuV/m)	Limits (dBuV/m)	Margin (dB)	Remark
1	10360.00	38.26	13.34	29.52	36.30	44.82	54.00	9.18	Average
2	10360.00	38.26	13.34	41.83	36.30	57.13	74.00	16.87	Peak

Remarks: 1. Emission Level= Antenna Factor + Cable Loss + Reading - Amp Factor
 2. The emission levels that are 20dB below the official limit are not reported.

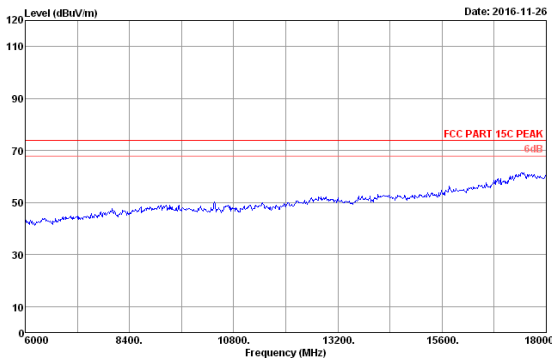

Site no. : 3m Chamber Data no. : 31
 Dis. / Ant. : 3m 2016 MCTD1209 3007 Ant. pol. : VERTICAL
 Limit : FCC PART 15C PEAK Pre : 101.2kPa
 Env. / Ins. : 23.14C/54.9W Engineer : Lynn
 EUT : CaptionCall Wireless Router 2
 Power rating : DC 9V From Adapter Input AC 120V/60Hz
 Test Mode : IEEE802.11n HT20 5180MHz Tx Mode
 M/N:CR2

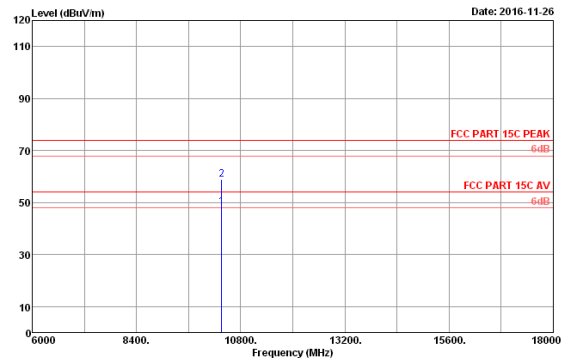

Site no. : 3m Chamber Data no. : 32
 Dis. / Ant. : 3m 2016 MCTD1209 3007 Ant. pol. : VERTICAL
 Limit : FCC PART 15C PEAK Pre : 101.2kPa
 Env. / Ins. : 23.14C/54.9W Engineer : Lynn
 EUT : CaptionCall Wireless Router 2
 Power rating : DC 9V From Adapter Input AC 120V/60Hz
 Test Mode : IEEE802.11n HT20 5180MHz Tx Mode
 M/N:CR2

No.	Freq. (MHz)	Ant. Factor (dB/m)	Cable Loss (dB)	Reading (dBuV)	AMP factor (dB)	Emission Level (dBuV/m)	Limits (dBuV/m)	Margin (dB)	Remark
1	10360.00	38.26	13.34	33.11	36.30	48.41	54.00	5.59	Average
2	10360.00	38.26	13.34	43.72	36.30	59.02	74.00	14.98	Peak

Remarks: 1. Emission Level= Antenna Factor + Cable Loss + Reading - Amp Factor
 2. The emission levels that are 20dB below the official limit are not reported.

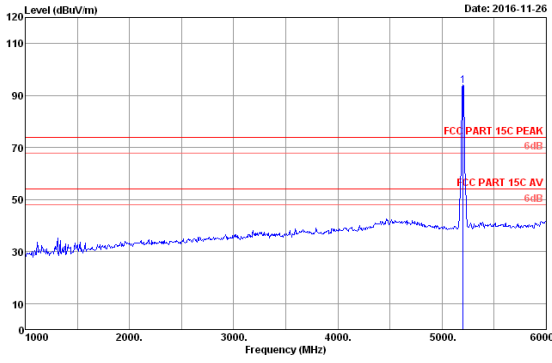

Site no. : 3m Chamber Data no. : 37
 Dis. / Ant. : 3m 2016 MCTD1209 3007 Ant. pol. : HORIZONTAL
 Limit : FCC PART 15C PEAK Pre : 101.2kPa
 Env. / Ins. : 23.1°C/54.9% Engineer : Lynn
 EUT : CaptionCall Wireless Router 2
 Power rating : DC 9V From Adapter Input AC 120V/60Hz
 Test Mode : IEEE802.11n HT20 5200MHz Tx Mode
 M/N:CR2

No.	Freq. (MHz)	Ant. Factor (dB/m)	Cable Loss (dB)	Reading (dBuV)	AMP factor (dB)	Emission Level (dBuV/m)	Limits (dBuV/m)	Margin (dB)	Remark
1	5200.00	32.40	11.91	85.03	35.61	93.73	74.00	-19.73	Peak

Remarks: 1. Emission Level= Antenna Factor + Cable Loss + Reading - Amp Factor
 2. The emission levels that are 20dB below the official limit are not reported.

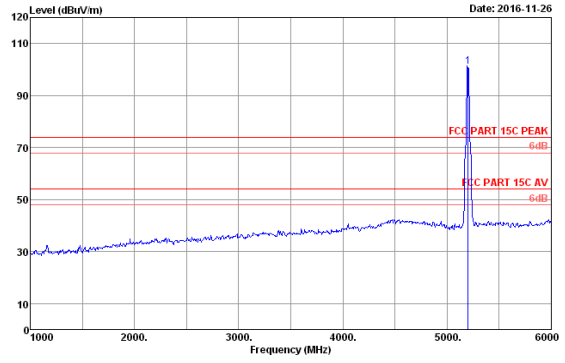

Site no. : 3m Chamber Data no. : 38
 Dis. / Ant. : 3m 2016 MCTD1209 3007 Ant. pol. : VERTICAL
 Limit : FCC PART 15C PEAK Pre : 101.2kPa
 Env. / Ins. : 23.1°C/54.9% Engineer : Lynn
 EUT : CaptionCall Wireless Router 2
 Power rating : DC 9V From Adapter Input AC 120V/60Hz
 Test Mode : IEEE802.11n HT20 5200MHz Tx Mode
 M/N:CR2

No.	Freq. (MHz)	Ant. Factor (dB/m)	Cable Loss (dB)	Reading (dBuV)	AMP factor (dB)	Emission Level (dBuV/m)	Limits (dBuV/m)	Margin (dB)	Remark
1	5200.00	32.40	11.91	92.34	35.61	101.04	74.00	-27.04	Peak

Remarks: 1. Emission Level= Antenna Factor + Cable Loss + Reading - Amp Factor
 2. The emission levels that are 20dB below the official limit are not reported.

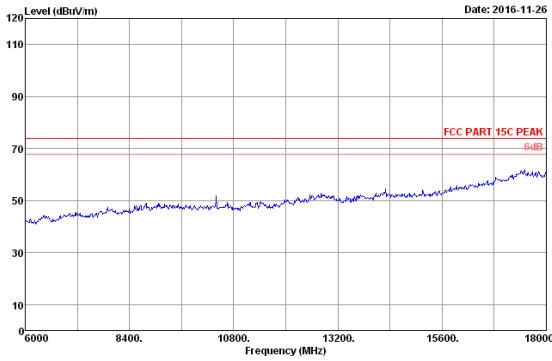

Site no. : 3m Chamber Data no. : 39
 Dis. / Ant. : 3m 2016 MCTD1209 3007 Ant. pol. : VERTICAL
 Limit : FCC PART 15C PEAK Pre : 101.2kPa
 Env. / Ins. : 23.1°C/54.9% Engineer : Lynn
 EUT : CaptionCall Wireless Router 2
 Power rating : DC 9V From Adapter Input AC 120V/60Hz
 Test Mode : IEEE802.11n HT20 5200MHz Tx Mode
 M/N:CR2

No.	Freq. (MHz)	Ant. Factor (dB/m)	Cable Loss (dB)	Reading (dBuV)	AMP factor (dB)	Emission Level (dBuV/m)	Limits (dBuV/m)	Margin (dB)	Remark
1	10400.00	38.30	13.35	33.12	36.31	48.46	54.00	5.54	Average
2	10400.00	38.30	13.35	44.87	36.31	60.21	74.00	13.79	Peak

Remarks: 1. Emission Level= Antenna Factor + Cable Loss + Reading - Amp Factor
 2. The emission levels that are 20dB below the official limit are not reported.

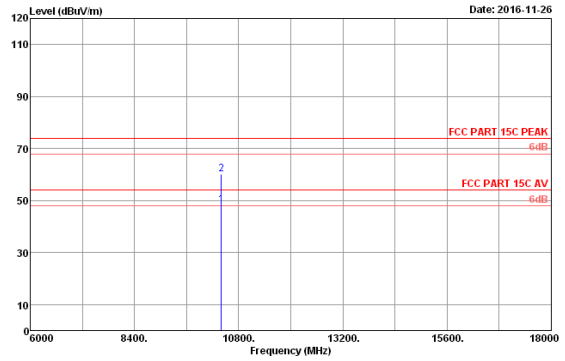

Site no. : 3m Chamber Data no. : 40
 Dis. / Ant. : 3m 2016 MCTD1209 3007 Ant. pol. : VERTICAL
 Limit : FCC PART 15C PEAK Pre : 101.2kPa
 Env. / Ins. : 23.1°C/54.9% Engineer : Lynn
 EUT : CaptionCall Wireless Router 2
 Power rating : DC 9V From Adapter Input AC 120V/60Hz
 Test Mode : IEEE802.11n HT20 5200MHz Tx Mode
 M/N:CR2

No.	Freq. (MHz)	Ant. Factor (dB/m)	Cable Loss (dB)	Reading (dBuV)	AMP factor (dB)	Emission Level (dBuV/m)	Limits (dBuV/m)	Margin (dB)	Remark
1	10400.00	38.30	13.35	33.12	36.31	48.46	54.00	5.54	Average
2	10400.00	38.30	13.35	44.87	36.31	60.21	74.00	13.79	Peak

Remarks: 1. Emission Level= Antenna Factor + Cable Loss + Reading - Amp Factor
 2. The emission levels that are 20dB below the official limit are not reported.

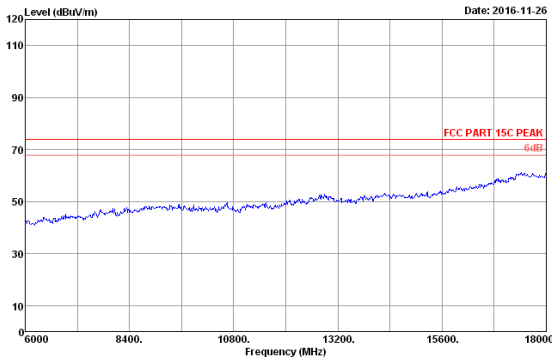

Site no. : 3m Chamber Data no. : 41
 Dis. / Ant. : 3m 2016 MCTD1209 3007 Ant. pol. : HORIZONTAL
 Limit : FCC PART 15C PEAK Pre : 101.2kPa
 Env. / Ins. : 23.1°C/54.9% Engineer : Lynn
 EUT : CaptionCall Wireless Router 2
 Power rating : DC 9V From Adapter Input AC 120V/60Hz
 Test Mode : IEEE802.11n HT20 5200MHz Tx Mode
 M/N:CR2

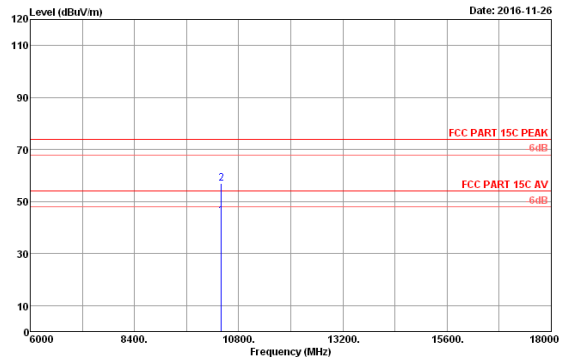

Site no. : 3m Chamber Data no. : 42
 Dis. / Ant. : 3m 2016 MCTD1209 3007 Ant. pol. : HORIZONTAL
 Limit : FCC PART 15C PEAK Pre : 101.2kPa
 Env. / Ins. : 23.1°C/54.9% Engineer : Lynn
 EUT : CaptionCall Wireless Router 2
 Power rating : DC 9V From Adapter Input AC 120V/60Hz
 Test Mode : IEEE802.11n HT20 5200MHz Tx Mode
 M/N:CR2

No.	Freq. (MHz)	Ant. Factor (dB/m)	Cable Loss (dB)	Reading (dBuV)	AMP factor (dB)	Emission Level (dBuV/m)	Limits (dBuV/m)	Margin (dB)	Remark
1	10400.00	38.30	13.35	29.16	36.31	44.50	54.00	9.50	Average
2	10400.00	38.30	13.35	41.49	36.31	56.83	74.00	17.17	Peak

Remarks: 1. Emission Level= Antenna Factor + Cable Loss + Reading - Amp Factor
 2. The emission levels that are 20dB below the official limit are not reported.

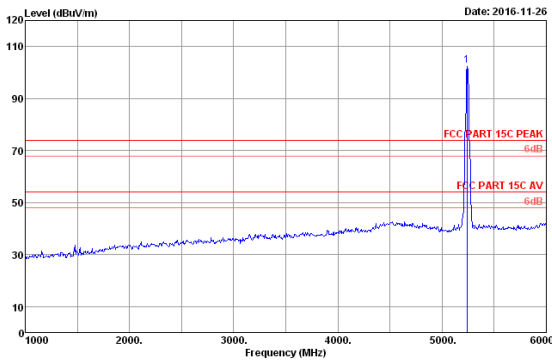

Site no. : 3m Chamber Data no. : 43
 Dis. / Ant. : 3m 2016 MCTD1209 3007 Ant. pol. : VERTICAL
 Limit : FCC PART 15C PEAK Pre : 101.2kPa
 Env. / Ins. : 23.1°C/54.9% Engineer : Lynn
 EUT : CaptionCall Wireless Router 2
 Power rating : DC 9V From Adapter Input AC 120V/60Hz
 Test Mode : IEEE802.11n HT20 5240MHz Tx Mode
 M/N:CR2

No.	Freq. (MHz)	Ant. Factor (dB/m)	Cable Loss (dB)	Reading (dBuV)	AMP factor (dB)	Emission Level (dBuV/m)	Limits (dBuV/m)	Margin (dB)	Remark
1	5240.00	32.40	11.91	94.15	35.59	102.87	74.00	-28.87	Peak

Remarks: 1. Emission Level= Antenna Factor + Cable Loss + Reading - Amp Factor
 2. The emission levels that are 20dB below the official limit are not reported.

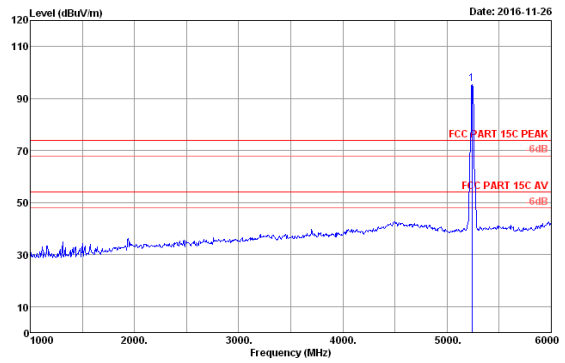

Site no. : 3m Chamber Data no. : 44
 Dis. / Ant. : 3m 2016 MCTD1209 3007 Ant. pol. : HORIZONTAL
 Limit : FCC PART 15C PEAK Pre : 101.2kPa
 Env. / Ins. : 23.1°C/54.9% Engineer : Lynn
 EUT : CaptionCall Wireless Router 2
 Power rating : DC 9V From Adapter Input AC 120V/60Hz
 Test Mode : IEEE802.11n HT20 5240MHz Tx Mode
 M/N:CR2

No.	Freq. (MHz)	Ant. Factor (dB/m)	Cable Loss (dB)	Reading (dBuV)	AMP factor (dB)	Emission Level (dBuV/m)	Limits (dBuV/m)	Margin (dB)	Remark
1	5240.00	32.40	11.91	86.98	35.59	95.70	74.00	-21.70	Peak

Remarks: 1. Emission Level= Antenna Factor + Cable Loss + Reading - Amp Factor
 2. The emission levels that are 20dB below the official limit are not reported.

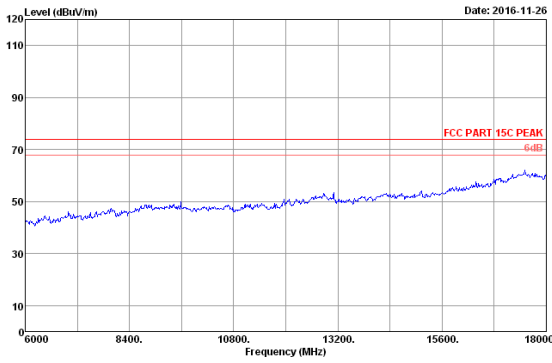

Site no. : 3m Chamber Data no. : 45
 Dis. / Ant. : 3m 2016 MCTD1209 3007 Ant. pol. : HORIZONTAL
 Limit : FCC PART 15C PEAK Pre : 101.2kPa
 Env. / Ins. : 23.1°C/54.9% Engineer : Lynn
 EUT : CaptionCall Wireless Router 2
 Power rating : DC 9V From Adapter Input AC 120V/60Hz
 Test Mode : IEEE802.11n HT20 5240MHz Tx Mode
 M/N:CR2

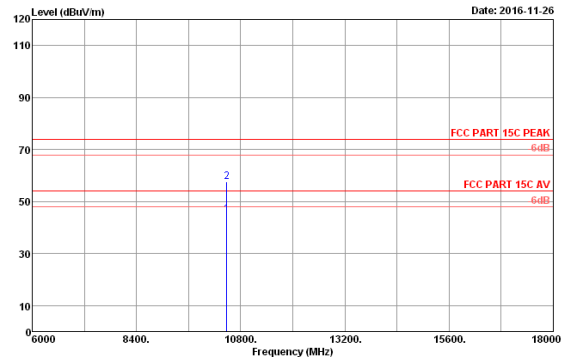

Site no. : 3m Chamber Data no. : 46
 Dis. / Ant. : 3m 2016 MCTD1209 3007 Ant. pol. : HORIZONTAL
 Limit : FCC PART 15C PEAK Pre : 101.2kPa
 Env. / Ins. : 23.1°C/54.9% Engineer : Lynn
 EUT : CaptionCall Wireless Router 2
 Power rating : DC 9V From Adapter Input AC 120V/60Hz
 Test Mode : IEEE802.11n HT20 5240MHz Tx Mode
 M/N:CR2

No.	Freq. (MHz)	Ant. Factor (dB/m)	Cable Loss (dB)	Reading (dBuV)	AMP factor (dB)	Emission Level (dBuV/m)	Limits (dBuV/m)	Margin (dB)	Remark
1	10480.00	38.38	13.37	29.59	36.32	45.02	54.00	8.98	Average
2	10480.00	38.38	13.37	42.20	36.32	57.63	74.00	16.37	Peak

Remarks: 1. Emission Level= Antenna Factor + Cable Loss + Reading - Amp Factor
 2. The emission levels that are 20dB below the official limit are not reported.

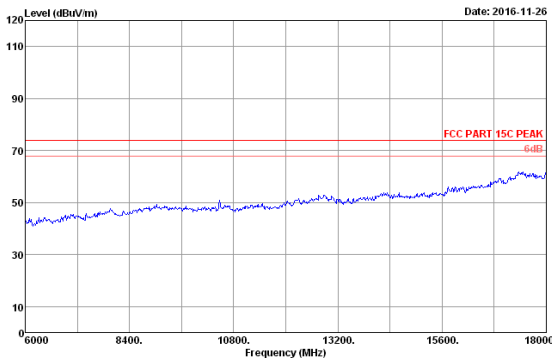

Site no. : 3m Chamber Data no. : 47
 Dis. / Ant. : 3m 2016 MCTD1209 3007 Ant. pol. : VERTICAL
 Limit : FCC PART 15C PEAK Pre : 101.2kPa
 Env. / Ins. : 23.1°C/54.9% Engineer : Lynn
 EUT : CaptionCall Wireless Router 2
 Power rating : DC 9V From Adapter Input AC 120V/60Hz
 Test Mode : IEEE802.11n HT20 5240MHz Tx Mode
 M/N:CR2

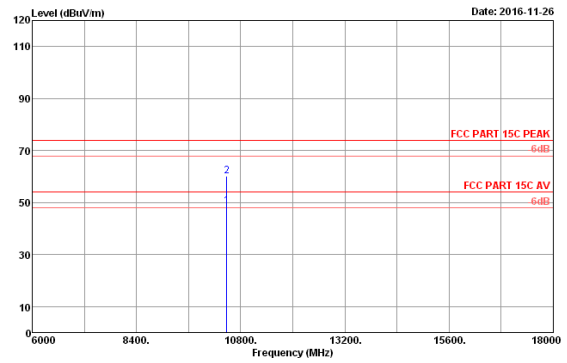

Site no. : 3m Chamber Data no. : 48
 Dis. / Ant. : 3m 2016 MCTD1209 3007 Ant. pol. : VERTICAL
 Limit : FCC PART 15C PEAK Pre : 101.2kPa
 Env. / Ins. : 23.1°C/54.9% Engineer : Lynn
 EUT : CaptionCall Wireless Router 2
 Power rating : DC 9V From Adapter Input AC 120V/60Hz
 Test Mode : IEEE802.11n HT20 5240MHz Tx Mode
 M/N:CR2

No.	Freq. (MHz)	Ant. Factor (dB/m)	Cable Loss (dB)	Reading (dBuV)	AMP factor (dB)	Emission Level (dBuV/m)	Limits (dBuV/m)	Margin (dB)	Remark
1	10480.00	38.38	13.37	33.06	36.32	48.49	54.00	5.51	Average
2	10480.00	38.38	13.37	44.89	36.32	60.32	74.00	13.68	Peak

Remarks: 1. Emission Level= Antenna Factor + Cable Loss + Reading - Amp Factor
 2. The emission levels that are 20dB below the official limit are not reported.

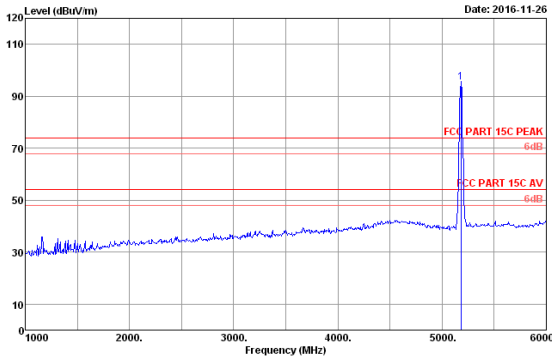

Site no. : 3m Chamber Data no. : 53
 Dis. / Ant. : 3m 2016 MCTD1209 3007 Ant. pol. : HORIZONTAL
 Limit : FCC PART 15C PEAK Pre : 101.2kPa
 Env. / Ins. : 23.1kV/54.9kV Engineer : Lynn
 EUT : CaptionCall Wireless Router 2
 Power rating : DC 9V From Adapter Input AC 120V/60Hz
 Test Mode : IEEE802.11ac VHT20 5180MHz Tx Mode
 M/N:CR2

No.	Freq. (MHz)	Ant. Factor (dB/m)	Cable Loss (dB)	Reading (dBuV)	AMP factor (dB)	Emission Level (dBuV/m)	Limits (dBuV/m)	Margin (dB)	Remark
1	5180.00	32.40	11.91	86.77	35.62	95.46	74.00	-21.46	Peak

Remarks: 1. Emission Level= Antenna Factor + Cable Loss + Reading - Amp Factor
 2. The emission levels that are 20dB below the official limit are not reported.

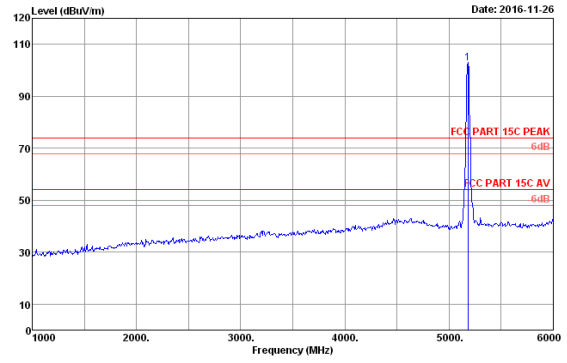

Site no. : 3m Chamber Data no. : 54
 Dis. / Ant. : 3m 2016 MCTD1209 3007 Ant. pol. : VERTICAL
 Limit : FCC PART 15C PEAK Pre : 101.2kPa
 Env. / Ins. : 23.1kV/54.9kV Engineer : Lynn
 EUT : CaptionCall Wireless Router 2
 Power rating : DC 9V From Adapter Input AC 120V/60Hz
 Test Mode : IEEE802.11ac VHT20 5180MHz Tx Mode
 M/N:CR2

No.	Freq. (MHz)	Ant. Factor (dB/m)	Cable Loss (dB)	Reading (dBuV)	AMP factor (dB)	Emission Level (dBuV/m)	Limits (dBuV/m)	Margin (dB)	Remark
1	5180.00	32.40	11.91	94.02	35.62	102.71	74.00	-28.71	Peak

Remarks: 1. Emission Level= Antenna Factor + Cable Loss + Reading - Amp Factor
 2. The emission levels that are 20dB below the official limit are not reported.

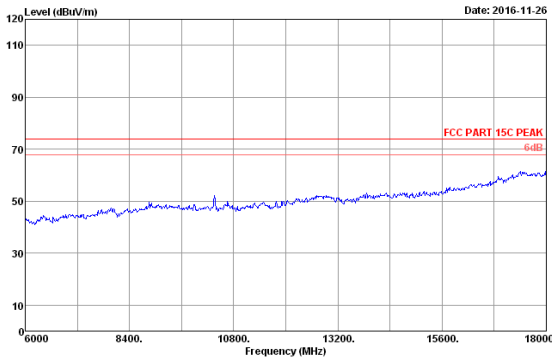

Site no. : 3m Chamber Data no. : 55
 Dis. / Ant. : 3m 2016 MCTD1209 3007 Ant. pol. : VERTICAL
 Limit : FCC PART 15C PEAK Pre : 101.2kPa
 Env. / Ins. : 23.1kV/54.9kV Engineer : Lynn
 EUT : CaptionCall Wireless Router 2
 Power rating : DC 9V From Adapter Input AC 120V/60Hz
 Test Mode : IEEE802.11ac VHT20 5180MHz Tx Mode
 M/N:CR2

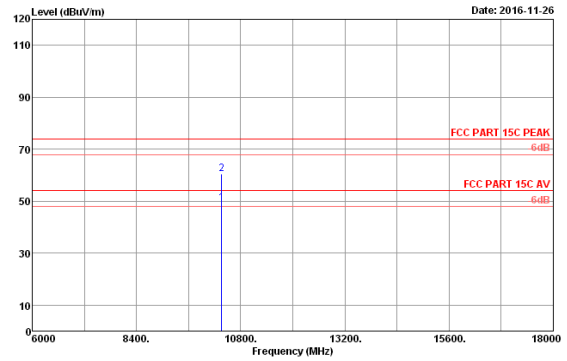

Site no. : 3m Chamber Data no. : 56
 Dis. / Ant. : 3m 2016 MCTD1209 3007 Ant. pol. : VERTICAL
 Limit : FCC PART 15C PEAK Pre : 101.2kPa
 Env. / Ins. : 23.1kV/54.9kV Engineer : Lynn
 EUT : CaptionCall Wireless Router 2
 Power rating : DC 9V From Adapter Input AC 120V/60Hz
 Test Mode : IEEE802.11ac VHT20 5180MHz Tx Mode
 M/N:CR2

No.	Freq. (MHz)	Ant. Factor (dB/m)	Cable Loss (dB)	Reading (dBuV)	AMP factor (dB)	Emission Level (dBuV/m)	Limits (dBuV/m)	Margin (dB)	Remark
1	10360.00	38.26	13.34	33.85	36.30	49.15	54.00	4.85	Average
2	10360.00	38.26	13.34	45.03	36.30	60.33	74.00	13.67	Peak

Remarks: 1. Emission Level= Antenna Factor + Cable Loss + Reading - Amp Factor
 2. The emission levels that are 20dB below the official limit are not reported.

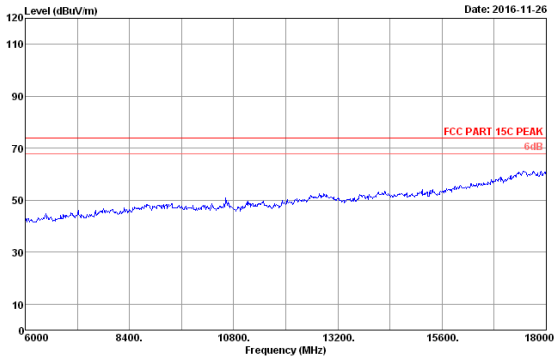

Site no. : 3m Chamber Data no. : 57
 Dis. / Ant. : 3m 2016 MCTD1209 3007 Ant. pol. : HORIZONTAL
 Limit : FCC PART 15C PEAK Pre : 101.2kPa
 Env. / Ins. : 23.1kV/54.9kV Engineer : Lynn
 EUT : CaptionCall Wireless Router 2
 Power rating : DC 9V From Adapter Input AC 120V/60Hz
 Test Mode : IEEE802.11ac VHT20 5180MHz Tx Mode
 M/N:CR2

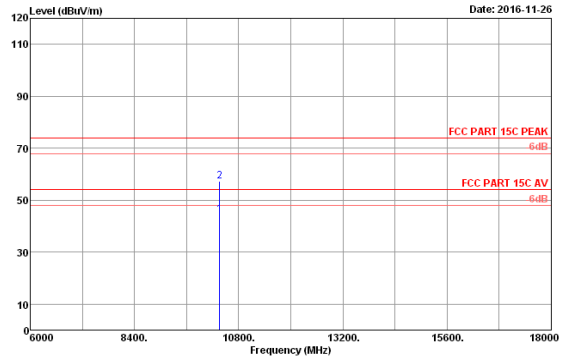

Site no. : 3m Chamber Data no. : 58
 Dis. / Ant. : 3m 2016 MCTD1209 3007 Ant. pol. : HORIZONTAL
 Limit : FCC PART 15C PEAK Pre : 101.2kPa
 Env. / Ins. : 23.1kV/54.9kV Engineer : Lynn
 EUT : CaptionCall Wireless Router 2
 Power rating : DC 9V From Adapter Input AC 120V/60Hz
 Test Mode : IEEE802.11ac VHT20 5180MHz Tx Mode
 M/N:CR2

No.	Freq. (MHz)	Ant. Factor (dB/m)	Cable Loss (dB)	Reading (dBuV)	AMP factor (dB)	Emission Level (dBuV/m)	Limits (dBuV/m)	Margin (dB)	Remark
1	10360.00	38.26	13.34	29.12	36.30	44.42	54.00	9.58	Average
2	10360.00	38.26	13.34	42.06	36.30	57.36	74.00	16.64	Peak

Remarks: 1. Emission Level= Antenna Factor + Cable Loss + Reading - Amp Factor
 2. The emission levels that are 20dB below the official limit are not reported.

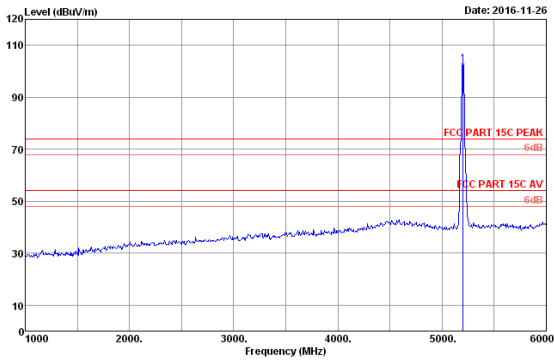

Site no. : 3m Chamber Data no. : 63
 Dis. / Ant. : 3m 2016 MCTD1209 3007 Ant. pol. : VERTICAL
 Limit : FCC PART 15C PEAK Pre : 101.2kPa
 Env. / Ins. : 23.1kV/54.9kV Engineer : Lynn
 EUT : CaptionCall Wireless Router 2
 Power rating : DC 9V From Adapter Input AC 120V/60Hz
 Test Mode : IEEE802.11ac VHT20 5200MHz Tx Mode
 M/N:CR2

No.	Freq. (MHz)	Ant. Factor (dB/m)	Cable Loss (dB)	Reading (dBuV)	AMP factor (dB)	Emission Level (dBuV/m)	Limits (dBuV/m)	Margin (dB)	Remark
1	5200.00	32.40	11.91	94.11	35.61	102.81	74.00	-28.81	Peak

Remarks: 1. Emission Level= Antenna Factor + Cable Loss + Reading - Amp Factor
 2. The emission levels that are 20dB below the official limit are not reported.

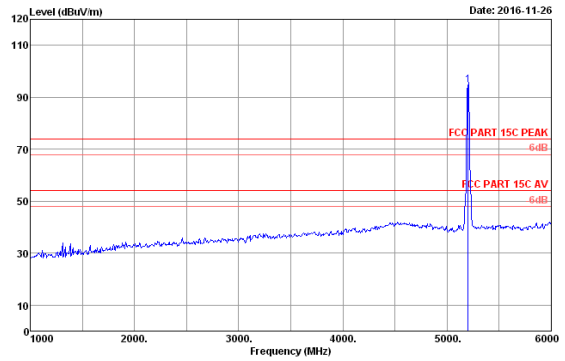

Site no. : 3m Chamber Data no. : 64
 Dis. / Ant. : 3m 2016 MCTD1209 3007 Ant. pol. : HORIZONTAL
 Limit : FCC PART 15C PEAK Pre : 101.2kPa
 Env. / Ins. : 23.1kV/54.9kV Engineer : Lynn
 EUT : CaptionCall Wireless Router 2
 Power rating : DC 9V From Adapter Input AC 120V/60Hz
 Test Mode : IEEE802.11ac VHT20 5200MHz Tx Mode
 M/N:CR2

No.	Freq. (MHz)	Ant. Factor (dB/m)	Cable Loss (dB)	Reading (dBuV)	AMP factor (dB)	Emission Level (dBuV/m)	Limits (dBuV/m)	Margin (dB)	Remark
1	5200.00	32.40	11.91	86.17	35.61	94.87	74.00	-20.87	Peak

Remarks: 1. Emission Level= Antenna Factor + Cable Loss + Reading - Amp Factor
 2. The emission levels that are 20dB below the official limit are not reported.

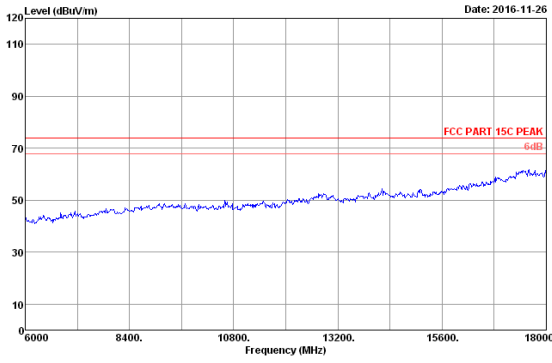

Site no. : 3m Chamber Data no. : 65
 Dis. / Ant. : 3m 2016 MCTD1209 3007 Ant. pol. : HORIZONTAL
 Limit : FCC PART 15C PEAK Pre : 101.2kPa
 Env. / Ins. : 23.1kV/54.9kV Engineer : Lynn
 EUT : CaptionCall Wireless Router 2
 Power rating : DC 9V From Adapter Input AC 120V/60Hz
 Test Mode : IEEE802.11ac VHT20 5200MHz Tx Mode
 M/N:CR2

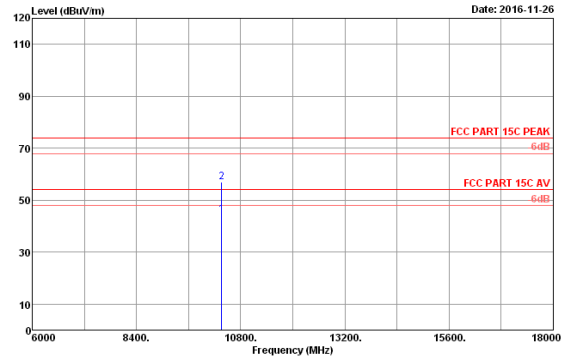

Site no. : 3m Chamber Data no. : 66
 Dis. / Ant. : 3m 2016 MCTD1209 3007 Ant. pol. : HORIZONTAL
 Limit : FCC PART 15C PEAK Pre : 101.2kPa
 Env. / Ins. : 23.1kV/54.9kV Engineer : Lynn
 EUT : CaptionCall Wireless Router 2
 Power rating : DC 9V From Adapter Input AC 120V/60Hz
 Test Mode : IEEE802.11ac VHT20 5200MHz Tx Mode
 M/N:CR2

No.	Freq. (MHz)	Ant. Factor (dB/m)	Cable Loss (dB)	Reading (dBuV)	AMP factor (dB)	Emission Level (dBuV/m)	Limits (dBuV/m)	Margin (dB)	Remark
1	10360.00	38.26	13.34	29.22	36.30	44.52	54.00	9.48	Average
2	10360.00	38.26	13.34	41.61	36.30	56.91	74.00	17.09	Peak

Remarks: 1. Emission Level= Antenna Factor + Cable Loss + Reading - Amp Factor
 2. The emission levels that are 20dB below the official limit are not reported.

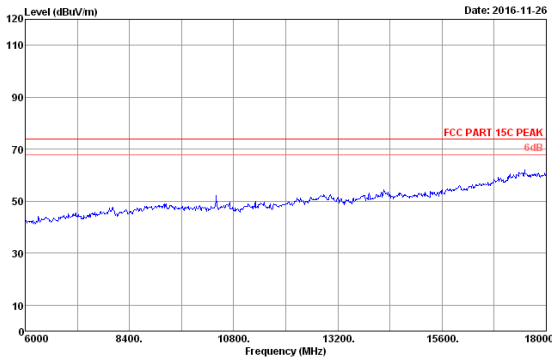

Site no. : 3m Chamber Data no. : 67
 Dis. / Ant. : 3m 2016 MCTD1209 3007 Ant. pol. : VERTICAL
 Limit : FCC PART 15C PEAK Pre : 101.2kPa
 Env. / Ins. : 23.1kV/54.9kV Engineer : Lynn
 EUT : CaptionCall Wireless Router 2
 Power rating : DC 9V From Adapter Input AC 120V/60Hz
 Test Mode : IEEE802.11ac VHT20 5200MHz Tx Mode
 M/N:CR2

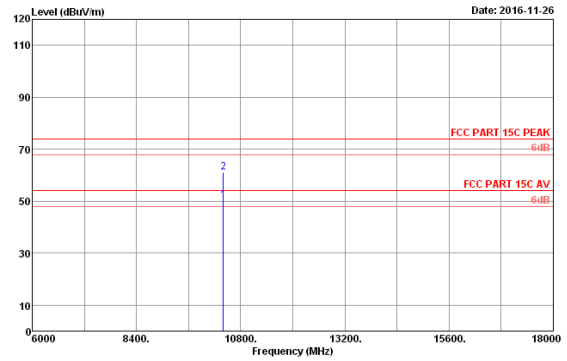

Site no. : 3m Chamber Data no. : 68
 Dis. / Ant. : 3m 2016 MCTD1209 3007 Ant. pol. : VERTICAL
 Limit : FCC PART 15C PEAK Pre : 101.2kPa
 Env. / Ins. : 23.1kV/54.9kV Engineer : Lynn
 EUT : CaptionCall Wireless Router 2
 Power rating : DC 9V From Adapter Input AC 120V/60Hz
 Test Mode : IEEE802.11ac VHT20 5200MHz Tx Mode
 M/N:CR2

No.	Freq. (MHz)	Ant. Factor (dB/m)	Cable Loss (dB)	Reading (dBuV)	AMP factor (dB)	Emission Level (dBuV/m)	Limits (dBuV/m)	Margin (dB)	Remark
1	10400.00	38.30	13.35	34.87	36.31	50.21	54.00	3.79	Average
2	10400.00	38.30	13.35	45.88	36.31	61.22	74.00	12.78	Peak

Remarks: 1. Emission Level= Antenna Factor + Cable Loss + Reading - Amp Factor
 2. The emission levels that are 20dB below the official limit are not reported.

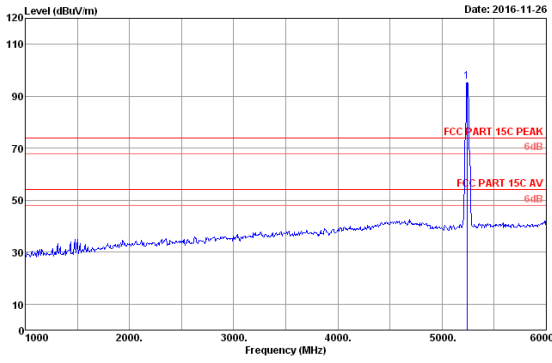

Site no. : 3m Chamber Data no. : 69
 Dis. / Ant. : 3m 2016 MCTD1209 3007 Ant. pol. : HORIZONTAL
 Limit : FCC PART 15C PEAK Pre : 101.2kPa
 Env. / Ins. : 23.1kV/54.9kV Engineer : Lynn
 EUT : CaptionCall Wireless Router 2
 Power rating : DC 9V From Adapter Input AC 120V/60Hz
 Test Mode : IEEE802.11ac VHT20 5240MHz Tx Mode
 M/N:CR2

No.	Freq. (MHz)	Ant. Factor (dB/m)	Cable Loss (dB)	Reading (dBuV)	AMP factor (dB)	Emission Level (dBuV/m)	Limits (dBuV/m)	Margin (dB)	Remark
1	5240.00	32.40	11.91	86.89	35.59	95.61	74.00	-21.61	Peak

Remarks: 1. Emission Level= Antenna Factor + Cable Loss + Reading - Amp Factor
 2. The emission levels that are 20dB below the official limit are not reported.

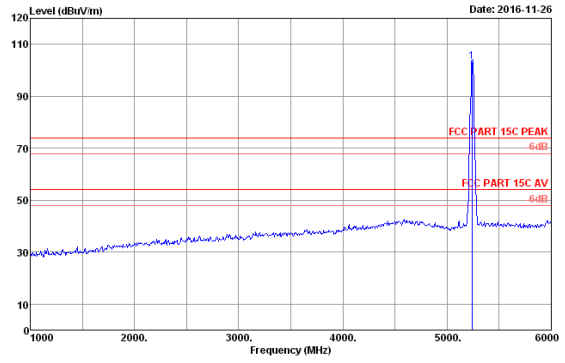

Site no. : 3m Chamber Data no. : 70
 Dis. / Ant. : 3m 2016 MCTD1209 3007 Ant. pol. : VERTICAL
 Limit : FCC PART 15C PEAK Pre : 101.2kPa
 Env. / Ins. : 23.1kV/54.9kV Engineer : Lynn
 EUT : CaptionCall Wireless Router 2
 Power rating : DC 9V From Adapter Input AC 120V/60Hz
 Test Mode : IEEE802.11ac VHT20 5240MHz Tx Mode
 M/N:CR2

No.	Freq. (MHz)	Ant. Factor (dB/m)	Cable Loss (dB)	Reading (dBuV)	AMP factor (dB)	Emission Level (dBuV/m)	Limits (dBuV/m)	Margin (dB)	Remark
1	5240.00	32.40	11.91	94.72	35.59	103.44	74.00	-29.44	Peak

Remarks: 1. Emission Level= Antenna Factor + Cable Loss + Reading - Amp Factor
 2. The emission levels that are 20dB below the official limit are not reported.

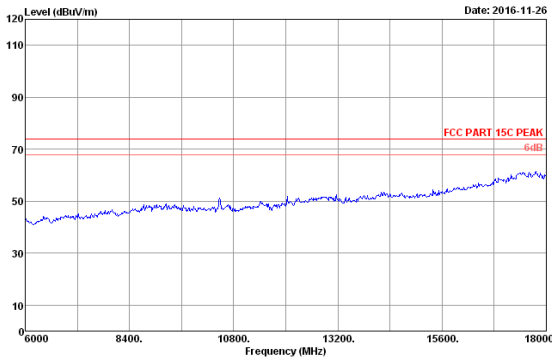

Site no. : 3m Chamber Data no. : 71
 Dis. / Ant. : 3m 2016 MCTD1209 3007 Ant. pol. : VERTICAL
 Limit : FCC PART 15C PEAK Pre : 101.2kPa
 Env. / Ins. : 23.1kV/54.9kV Engineer : Lynn
 EUT : CaptionCall Wireless Router 2
 Power rating : DC 9V From Adapter Input AC 120V/60Hz
 Test Mode : IEEE802.11ac VHT20 5240MHz Tx Mode
 M/N:CR2

No.	Freq. (MHz)	Ant. Factor (dB/m)	Cable Loss (dB)	Reading (dBuV)	AMP factor (dB)	Emission Level (dBuV/m)	Limits (dBuV/m)	Margin (dB)	Remark
1	10480.00	38.38	13.37	34.58	36.32	50.01	54.00	3.99	Average
2	10480.00	38.38	13.37	45.38	36.32	60.81	74.00	13.19	Peak

Remarks: 1. Emission Level= Antenna Factor + Cable Loss + Reading - Amp Factor
 2. The emission levels that are 20dB below the official limit are not reported.

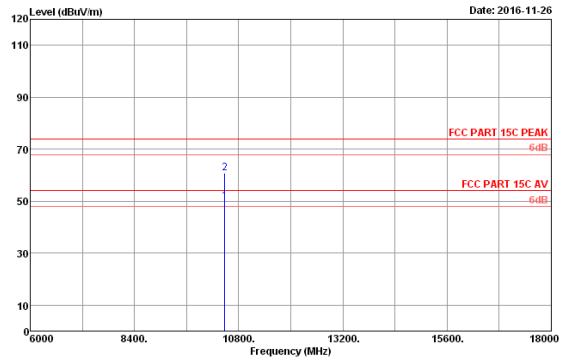

Site no. : 3m Chamber Data no. : 72
 Dis. / Ant. : 3m 2016 MCTD1209 3007 Ant. pol. : VERTICAL
 Limit : FCC PART 15C PEAK Pre : 101.2kPa
 Env. / Ins. : 23.1kV/54.9kV Engineer : Lynn
 EUT : CaptionCall Wireless Router 2
 Power rating : DC 9V From Adapter Input AC 120V/60Hz
 Test Mode : IEEE802.11ac VHT20 5240MHz Tx Mode
 M/N:CR2

No.	Freq. (MHz)	Ant. Factor (dB/m)	Cable Loss (dB)	Reading (dBuV)	AMP factor (dB)	Emission Level (dBuV/m)	Limits (dBuV/m)	Margin (dB)	Remark
1	10480.00	38.38	13.37	34.58	36.32	50.01	54.00	3.99	Average
2	10480.00	38.38	13.37	45.38	36.32	60.81	74.00	13.19	Peak

Remarks: 1. Emission Level= Antenna Factor + Cable Loss + Reading - Amp Factor
 2. The emission levels that are 20dB below the official limit are not reported.

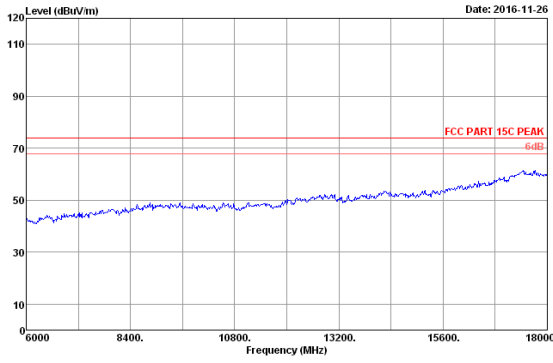

Site no. : 3m Chamber Data no. : 73
 Dis. / Ant. : 3m 2016 MCTD1209 3007 Ant. pol. : HORIZONTAL
 Limit : FCC PART 15C PEAK Pre : 101.2kPa
 Env. / Ins. : 23.1kV/54.9kV Engineer : Lynn
 EUT : CaptionCall Wireless Router 2
 Power rating : DC 9V From Adapter Input AC 120V/60Hz
 Test Mode : IEEE802.11ac VHT20 5240MHz Tx Mode
 M/N:CR2

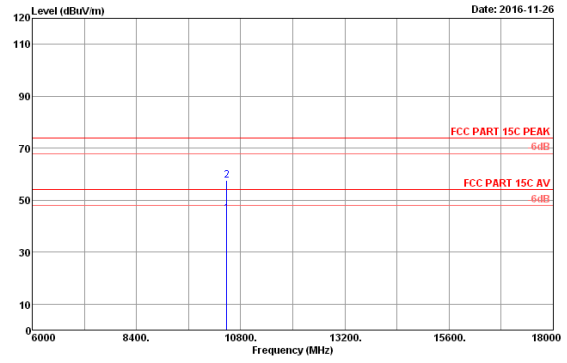

Site no. : 3m Chamber Data no. : 74
 Dis. / Ant. : 3m 2016 MCTD1209 3007 Ant. pol. : HORIZONTAL
 Limit : FCC PART 15C PEAK Pre : 101.2kPa
 Env. / Ins. : 23.1kV/54.9kV Engineer : Lynn
 EUT : CaptionCall Wireless Router 2
 Power rating : DC 9V From Adapter Input AC 120V/60Hz
 Test Mode : IEEE802.11ac VHT20 5240MHz Tx Mode
 M/N:CR2

No.	Freq. (MHz)	Ant. Factor (dB/m)	Cable Loss (dB)	Reading (dBuV)	AMP factor (dB)	Emission Level (dBuV/m)	Limits (dBuV/m)	Margin (dB)	Remark
1	10480.00	38.38	13.37	29.35	36.32	44.78	54.00	9.22	Average
2	10480.00	38.38	13.37	42.20	36.32	57.63	74.00	16.37	Peak

Remarks: 1. Emission Level= Antenna Factor + Cable Loss + Reading - Amp Factor
 2. The emission levels that are 20dB below the official limit are not reported.

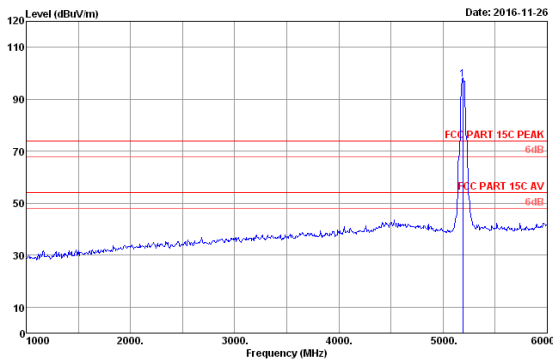

Site no. : 3m Chamber Data no. : 79
 Dis. / Ant. : 3m 2016 MCTD1209 3007 Ant. pol. : VERTICAL
 Limit : FCC PART 15C PEAK Pre : 101.2kPa
 Env. / Ins. : 23.1kV/54.9kV Engineer : Lynn
 EUT : CaptionCall Wireless Router 2
 Power rating : DC 9V From Adapter Input AC 120V/60Hz
 Test Mode : IEEE802.11n HT40 5190MHz Tx Mode
 M/N:CR2

No.	Freq. (MHz)	Ant. Factor (dB/m)	Cable Loss (dB)	Reading (dBuV)	AMP factor (dB)	Emission Level (dBuV/m)	Limits (dBuV/m)	Margin (dB)	Remark
1	5190.00	32.40	11.91	88.96	35.62	97.65	74.00	-23.65	Peak

Remarks: 1. Emission Level= Antenna Factor + Cable Loss + Reading - Amp Factor
 2. The emission levels that are 20dB below the official limit are not reported.

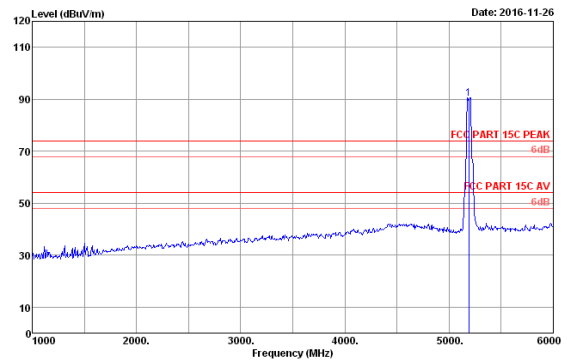

Site no. : 3m Chamber Data no. : 80
 Dis. / Ant. : 3m 2016 MCTD1209 3007 Ant. pol. : HORIZONTAL
 Limit : FCC PART 15C PEAK Pre : 101.2kPa
 Env. / Ins. : 23.1kV/54.9kV Engineer : Lynn
 EUT : CaptionCall Wireless Router 2
 Power rating : DC 9V From Adapter Input AC 120V/60Hz
 Test Mode : IEEE802.11n HT40 5190MHz Tx Mode
 M/N:CR2

No.	Freq. (MHz)	Ant. Factor (dB/m)	Cable Loss (dB)	Reading (dBuV)	AMP factor (dB)	Emission Level (dBuV/m)	Limits (dBuV/m)	Margin (dB)	Remark
1	5190.00	32.40	11.91	81.53	35.62	90.22	74.00	-16.22	Peak

Remarks: 1. Emission Level= Antenna Factor + Cable Loss + Reading - Amp Factor
 2. The emission levels that are 20dB below the official limit are not reported.

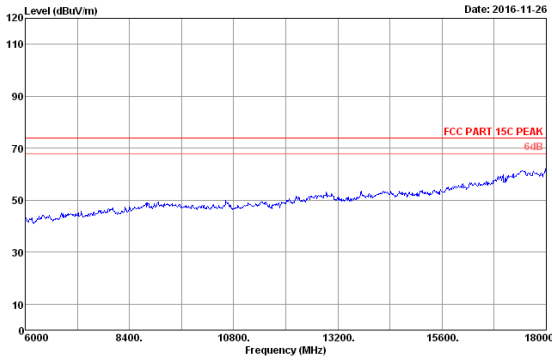

Site no. : 3m Chamber Data no. : 81
 Dis. / Ant. : 3m 2016 MCTD1209 3007 Ant. pol. : HORIZONTAL
 Limit : FCC PART 15C PEAK Pre : 101.2kPa
 Env. / Ins. : 23.1kV/54.9kV Engineer : Lynn
 EUT : CaptionCall Wireless Router 2
 Power rating : DC 9V From Adapter Input AC 120V/60Hz
 Test Mode : IEEE802.11n HT40 5180MHz Tx Mode
 M/N:CR2

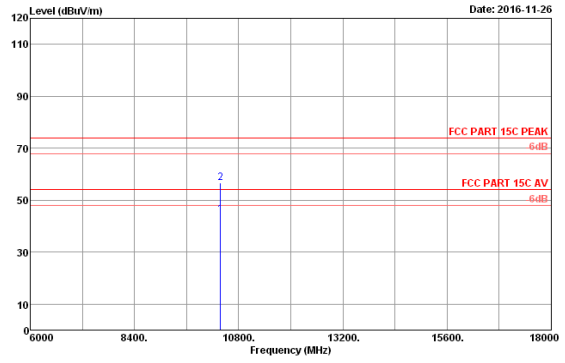

Site no. : 3m Chamber Data no. : 82
 Dis. / Ant. : 3m 2016 MCTD1209 3007 Ant. pol. : HORIZONTAL
 Limit : FCC PART 15C PEAK Pre : 101.2kPa
 Env. / Ins. : 23.1kV/54.9kV Engineer : Lynn
 EUT : CaptionCall Wireless Router 2
 Power rating : DC 9V From Adapter Input AC 120V/60Hz
 Test Mode : IEEE802.11n HT40 5180MHz Tx Mode
 M/N:CR2

No.	Freq. (MHz)	Ant. Factor (dB/m)	Cable Loss (dB)	Reading (dBuV)	AMP factor (dB)	Emission Level (dBuV/m)	Limits (dBuV/m)	Margin (dB)	Remark
1	10380.00	38.28	13.35	29.30	36.30	44.63	54.00	9.37	Average
2	10380.00	38.28	13.35	41.26	36.30	56.59	74.00	17.41	Peak

Remarks: 1. Emission Level= Antenna Factor + Cable Loss + Reading - Amp Factor
 2. The emission levels that are 20dB below the official limit are not reported.

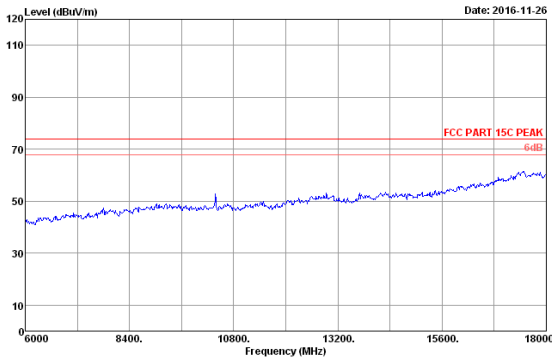

Site no. : 3m Chamber Data no. : 83
 Dis. / Ant. : 3m 2016 MCTD1209 3007 Ant. pol. : VERTICAL
 Limit : FCC PART 15C PEAK Pre : 101.2kPa
 Env. / Ins. : 23.1kV/54.9kV Engineer : Lynn
 EUT : CaptionCall Wireless Router 2
 Power rating : DC 9V From Adapter Input AC 120V/60Hz
 Test Mode : IEEE802.11n HT40 5180MHz Tx Mode
 M/N:CR2

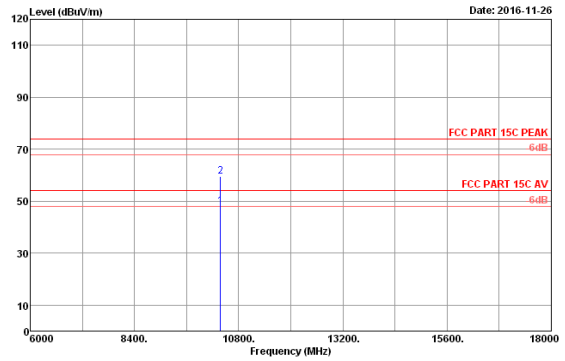

Site no. : 3m Chamber Data no. : 84
 Dis. / Ant. : 3m 2016 MCTD1209 3007 Ant. pol. : VERTICAL
 Limit : FCC PART 15C PEAK Pre : 101.2kPa
 Env. / Ins. : 23.1kV/54.9kV Engineer : Lynn
 EUT : CaptionCall Wireless Router 2
 Power rating : DC 9V From Adapter Input AC 120V/60Hz
 Test Mode : IEEE802.11n HT40 5180MHz Tx Mode
 M/N:CR2

No.	Freq. (MHz)	Ant. Factor (dB/m)	Cable Loss (dB)	Reading (dBuV)	AMP factor (dB)	Emission Level (dBuV/m)	Limits (dBuV/m)	Margin (dB)	Remark
1	10380.00	38.28	13.35	32.53	36.30	47.86	54.00	6.14	Average
2	10380.00	38.28	13.35	44.26	36.30	59.59	74.00	14.41	Peak

Remarks: 1. Emission Level= Antenna Factor + Cable Loss + Reading - Amp Factor
 2. The emission levels that are 20dB below the official limit are not reported.

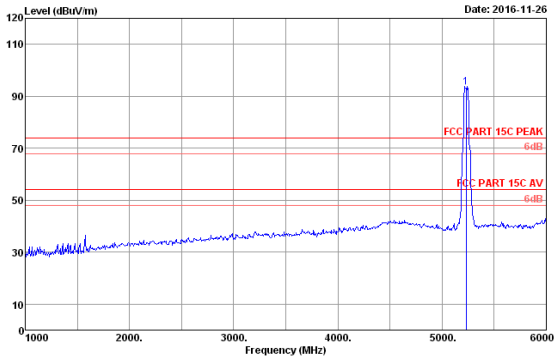

Site no. : 3m Chamber Data no. : 89
 Dis. / Ant. : 3m 2016 MCTD1209 3007 Ant. pol. : HORIZONTAL
 Limit : FCC PART 15C PEAK Pre : 101.2kPa
 Env. / Ins. : 23.1kV/54.9kV Engineer : Lynn
 EUT : CaptionCall Wireless Router 2
 Power rating : DC 9V From Adapter Input AC 120V/60Hz
 Test Mode : IEEE802.11n HT40 5230MHz Tx Mode
 M/N:CR2

No.	Freq. (MHz)	Ant. Factor (dB/m)	Cable Loss (dB)	Reading (dBuV)	AMP factor (dB)	Emission Level (dBuV/m)	Limits (dBuV/m)	Margin (dB)	Remark
1	5230.00	32.40	11.91	84.87	35.60	93.58	74.00	-19.58	Peak

Remarks: 1. Emission Level= Antenna Factor + Cable Loss + Reading - Amp Factor
 2. The emission levels that are 20dB below the official limit are not reported.

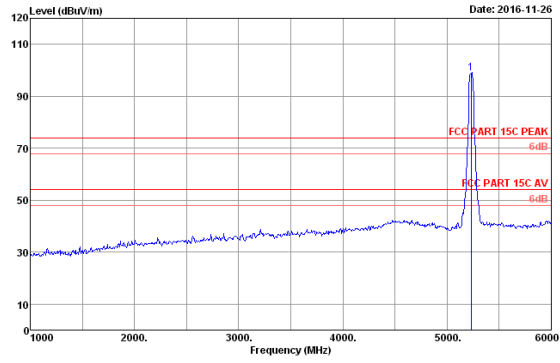

Site no. : 3m Chamber Data no. : 90
 Dis. / Ant. : 3m 2016 MCTD1209 3007 Ant. pol. : VERTICAL
 Limit : FCC PART 15C PEAK Pre : 101.2kPa
 Env. / Ins. : 23.1kV/54.9kV Engineer : Lynn
 EUT : CaptionCall Wireless Router 2
 Power rating : DC 9V From Adapter Input AC 120V/60Hz
 Test Mode : IEEE802.11n HT40 5230MHz Tx Mode
 M/N:CR2

No.	Freq. (MHz)	Ant. Factor (dB/m)	Cable Loss (dB)	Reading (dBuV)	AMP factor (dB)	Emission Level (dBuV/m)	Limits (dBuV/m)	Margin (dB)	Remark
1	5230.00	32.40	11.91	90.29	35.60	99.00	74.00	-25.00	Peak

Remarks: 1. Emission Level= Antenna Factor + Cable Loss + Reading - Amp Factor
 2. The emission levels that are 20dB below the official limit are not reported.

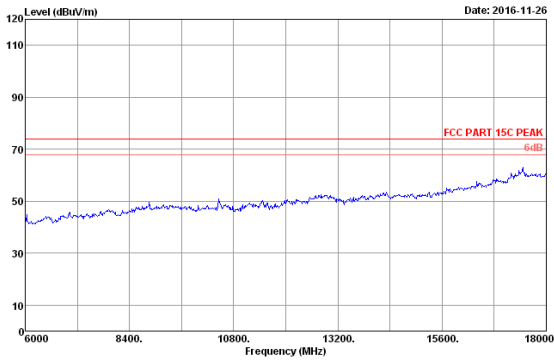

Site no. : 3m Chamber Data no. : 91
 Dis. / Ant. : 3m 2016 MCTD1209 3007 Ant. pol. : VERTICAL
 Limit : FCC PART 15C PEAK Pre : 101.2kPa
 Env. / Ins. : 23.1kV/54.9kV Engineer : Lynn
 EUT : CaptionCall Wireless Router 2
 Power rating : DC 9V From Adapter Input AC 120V/60Hz
 Test Mode : IEEE802.11n HT40 5230MHz Tx Mode
 M/N:CR2

No.	Freq. (MHz)	Ant. Factor (dB/m)	Cable Loss (dB)	Reading (dBuV)	AMP factor (dB)	Emission Level (dBuV/m)	Limits (dBuV/m)	Margin (dB)	Remark
1	10460.00	38.36	13.37	33.00	36.31	48.42	54.00	5.58	Average
2	10460.00	38.36	13.37	44.85	36.31	60.27	74.00	13.73	Peak

Remarks: 1. Emission Level= Antenna Factor + Cable Loss + Reading - Amp Factor
 2. The emission levels that are 20dB below the official limit are not reported.

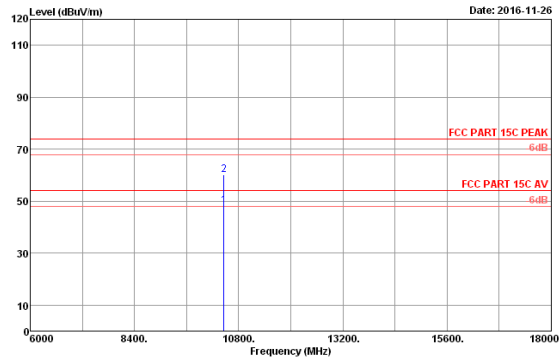

Site no. : 3m Chamber Data no. : 92
 Dis. / Ant. : 3m 2016 MCTD1209 3007 Ant. pol. : VERTICAL
 Limit : FCC PART 15C PEAK Pre : 101.2kPa
 Env. / Ins. : 23.1kV/54.9kV Engineer : Lynn
 EUT : CaptionCall Wireless Router 2
 Power rating : DC 9V From Adapter Input AC 120V/60Hz
 Test Mode : IEEE802.11n HT40 5230MHz Tx Mode
 M/N:CR2

No.	Freq. (MHz)	Ant. Factor (dB/m)	Cable Loss (dB)	Reading (dBuV)	AMP factor (dB)	Emission Level (dBuV/m)	Limits (dBuV/m)	Margin (dB)	Remark
1	10460.00	38.36	13.37	33.00	36.31	48.42	54.00	5.58	Average
2	10460.00	38.36	13.37	44.85	36.31	60.27	74.00	13.73	Peak

Remarks: 1. Emission Level= Antenna Factor + Cable Loss + Reading - Amp Factor
 2. The emission levels that are 20dB below the official limit are not reported.

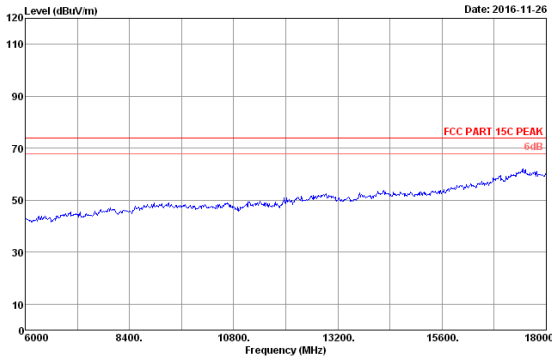

Site no. : 3m Chamber Data no. : 93
 Dis. / Ant. : 3m 2016 MCTD1209 3007 Ant. pol. : HORIZONTAL
 Limit : FCC PART 15C PEAK Pre : 101.2kPa
 Env. / Ins. : 23.1kV/54.9kV Engineer : Lynn
 EUT : CaptionCall Wireless Router 2
 Power rating : DC 9V From Adapter Input AC 120V/60Hz
 Test Mode : IEEE802.11n HT40 5230MHz Tx Mode
 M/N:CR2

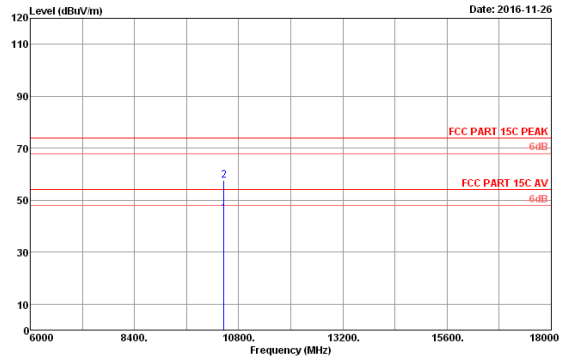

Site no. : 3m Chamber Data no. : 94
 Dis. / Ant. : 3m 2016 MCTD1209 3007 Ant. pol. : HORIZONTAL
 Limit : FCC PART 15C PEAK Pre : 101.2kPa
 Env. / Ins. : 23.1kV/54.9kV Engineer : Lynn
 EUT : CaptionCall Wireless Router 2
 Power rating : DC 9V From Adapter Input AC 120V/60Hz
 Test Mode : IEEE802.11n HT40 5230MHz Tx Mode
 M/N:CR2

No.	Freq. (MHz)	Ant. Factor (dB/m)	Cable Loss (dB)	Reading (dBuV)	AMP factor (dB)	Emission Level (dBuV/m)	Limits (dBuV/m)	Margin (dB)	Remark
1	10460.00	38.36	13.37	29.26	36.31	44.68	54.00	9.32	Average
2	10460.00	38.36	13.37	42.05	36.31	57.47	74.00	16.53	Peak

Remarks: 1. Emission Level= Antenna Factor + Cable Loss + Reading - Amp Factor
 2. The emission levels that are 20dB below the official limit are not reported.

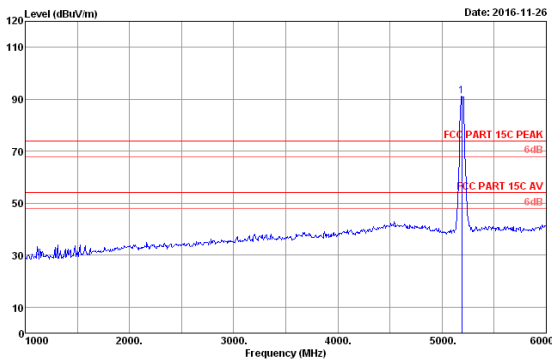

Site no. : 3m Chamber Data no. : 103
 Dis. / Ant. : 3m 2016 MCTD1209 3007 Ant. pol. : HORIZONTAL
 Limit : FCC PART 15C PEAK Pre : 101.2kPa
 Env. / Ins. : 23.1kV/54.9kV Engineer : Lynn
 EUT : CaptionCall Wireless Router 2
 Power rating : DC 9V From Adapter Input AC 120V/60Hz
 Test Mode : IEEE802.11ac VHT40 5190MHz Tx Mode
 M/N:CR2

No.	Freq. (MHz)	Ant. Factor (dB/m)	Cable Loss (dB)	Reading (dBuV)	AMP factor (dB)	Emission Level (dBuV/m)	Limits (dBuV/m)	Margin (dB)	Remark
1	5190.00	32.40	11.91	82.57	35.62	91.26	74.00	-17.26	Peak

Remarks: 1. Emission Level= Antenna Factor + Cable Loss + Reading - Amp Factor
 2. The emission levels that are 20dB below the official limit are not reported.

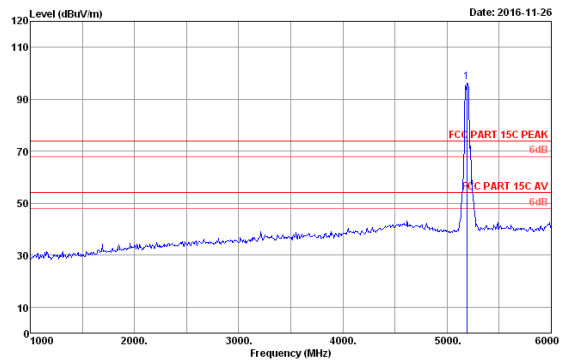

Site no. : 3m Chamber Data no. : 104
 Dis. / Ant. : 3m 2016 MCTD1209 3007 Ant. pol. : VERTICAL
 Limit : FCC PART 15C PEAK Pre : 101.2kPa
 Env. / Ins. : 23.1kV/54.9kV Engineer : Lynn
 EUT : CaptionCall Wireless Router 2
 Power rating : DC 9V From Adapter Input AC 120V/60Hz
 Test Mode : IEEE802.11ac VHT40 5190MHz Tx Mode
 M/N:CR2

No.	Freq. (MHz)	Ant. Factor (dB/m)	Cable Loss (dB)	Reading (dBuV)	AMP factor (dB)	Emission Level (dBuV/m)	Limits (dBuV/m)	Margin (dB)	Remark
1	5190.00	32.40	11.91	87.83	35.62	96.52	74.00	-22.52	Peak

Remarks: 1. Emission Level= Antenna Factor + Cable Loss + Reading - Amp Factor
 2. The emission levels that are 20dB below the official limit are not reported.

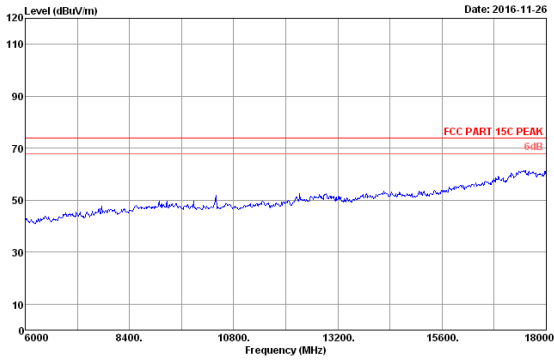

Site no. : 3m Chamber Data no. : 105
 Dis. / Ant. : 3m 2016 MCTD1209 3007 Ant. pol. : VERTICAL
 Limit : FCC PART 15C PEAK Pre : 101.2kPa
 Env. / Ins. : 23.1k/54.9% Engineer : Lynn
 EUT : CaptionCall Wireless Router 2
 Power rating : DC 9V From Adapter Input AC 120V/60Hz
 Test Mode : IEEE802.11ac VHT40 5180MHz Tx Mode
 M/N:CR2

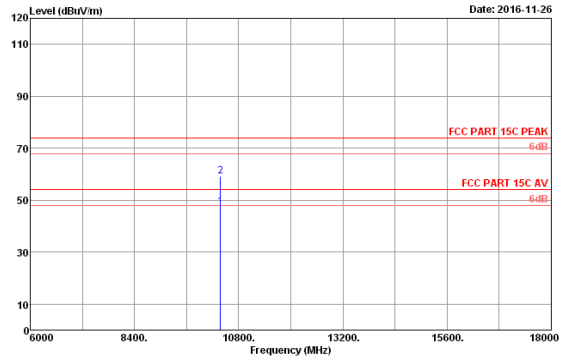

Site no. : 3m Chamber Data no. : 106
 Dis. / Ant. : 3m 2016 MCTD1209 3007 Ant. pol. : VERTICAL
 Limit : FCC PART 15C PEAK Pre : 101.2kPa
 Env. / Ins. : 23.1k/54.9% Engineer : Lynn
 EUT : CaptionCall Wireless Router 2
 Power rating : DC 9V From Adapter Input AC 120V/60Hz
 Test Mode : IEEE802.11ac VHT40 5180MHz Tx Mode
 M/N:CR2

No.	Freq. (MHz)	Ant. Factor (dB/m)	Cable Loss (dB)	Reading (dBuV)	AMP factor (dB)	Emission Level (dBuV/m)	Limits (dBuV/m)	Margin (dB)	Remark
1	10380.00	38.28	13.35	32.09	36.30	47.42	54.00	6.58	Average
2	10380.00	38.28	13.35	43.85	36.30	59.18	74.00	14.82	Peak

Remarks: 1. Emission Level= Antenna Factor + Cable Loss + Reading -Ant Factor
 2. The emission levels that are 20dB below the official limit are not reported.

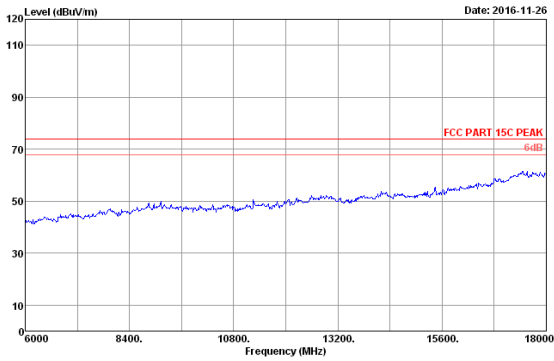

Site no. : 3m Chamber Data no. : 107
 Dis. / Ant. : 3m 2016 MCTD1209 3007 Ant. pol. : HORIZONTAL
 Limit : FCC PART 15C PEAK Pre : 101.2kPa
 Env. / Ins. : 23.1k/54.9% Engineer : Lynn
 EUT : CaptionCall Wireless Router 2
 Power rating : DC 9V From Adapter Input AC 120V/60Hz
 Test Mode : IEEE802.11ac VHT40 5180MHz Tx Mode
 M/N:CR2

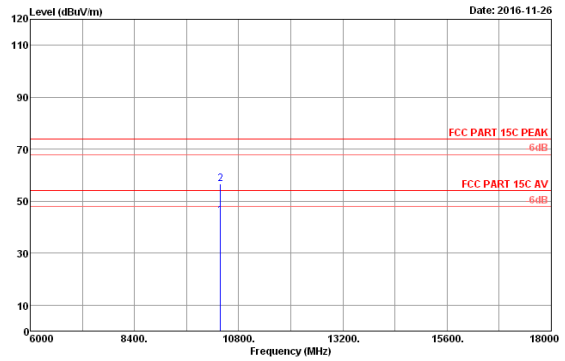

Site no. : 3m Chamber Data no. : 108
 Dis. / Ant. : 3m 2016 MCTD1209 3007 Ant. pol. : HORIZONTAL
 Limit : FCC PART 15C PEAK Pre : 101.2kPa
 Env. / Ins. : 23.1k/54.9% Engineer : Lynn
 EUT : CaptionCall Wireless Router 2
 Power rating : DC 9V From Adapter Input AC 120V/60Hz
 Test Mode : IEEE802.11ac VHT40 5180MHz Tx Mode
 M/N:CR2

No.	Freq. (MHz)	Ant. Factor (dB/m)	Cable Loss (dB)	Reading (dBuV)	AMP factor (dB)	Emission Level (dBuV/m)	Limits (dBuV/m)	Margin (dB)	Remark
1	10380.00	38.28	13.35	29.17	36.30	44.50	54.00	9.50	Average
2	10380.00	38.28	13.35	41.16	36.30	56.49	74.00	17.51	Peak

Remarks: 1. Emission Level= Antenna Factor + Cable Loss + Reading -Ant Factor
 2. The emission levels that are 20dB below the official limit are not reported.

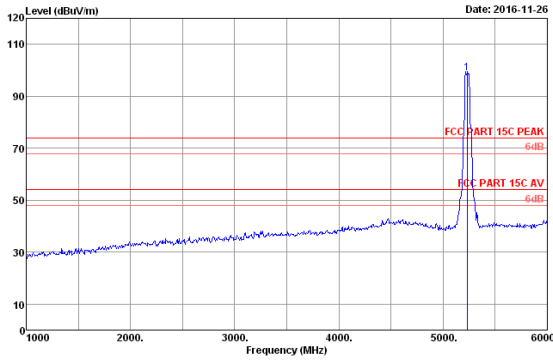

Site no. : 3m Chamber Data no. : 109
 Dis. / Ant. : 3m 2016 MCTD1209 3007 Ant. pol. : VERTICAL
 Limit : FCC PART 15C PEAK Pre : 101.2kPa
 Env. / Ins. : 23.1kV/54.9kV Engineer : Lynn
 EUT : CaptionCall Wireless Router 2
 Power rating : DC 9V From Adapter Input AC 120V/60Hz
 Test Mode : IEEE802.11ac VHT40 5230MHz Tx Mode
 M/N:CR2

No.	Freq. (MHz)	Ant. Factor (dB/m)	Cable Loss (dB)	Reading (dBuV)	AMP factor (dB)	Emission Level (dBuV/m)	Limits (dBuV/m)	Margin (dB)	Remark
1	5230.00	32.40	11.91	90.28	35.60	98.99	74.00	-24.99	Peak

Remarks: 1. Emission Level= Antenna Factor + Cable Loss + Reading - Amp Factor
 2. The emission levels that are 20dB below the official limit are not reported.

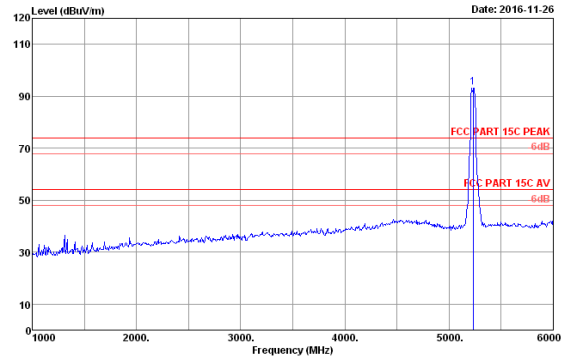

Site no. : 3m Chamber Data no. : 110
 Dis. / Ant. : 3m 2016 MCTD1209 3007 Ant. pol. : HORIZONTAL
 Limit : FCC PART 15C PEAK Pre : 101.2kPa
 Env. / Ins. : 23.1kV/54.9kV Engineer : Lynn
 EUT : CaptionCall Wireless Router 2
 Power rating : DC 9V From Adapter Input AC 120V/60Hz
 Test Mode : IEEE802.11ac VHT40 5230MHz Tx Mode
 M/N:CR2

No.	Freq. (MHz)	Ant. Factor (dB/m)	Cable Loss (dB)	Reading (dBuV)	AMP factor (dB)	Emission Level (dBuV/m)	Limits (dBuV/m)	Margin (dB)	Remark
1	5230.00	32.40	11.91	84.68	35.60	93.39	74.00	-19.39	Peak

Remarks: 1. Emission Level= Antenna Factor + Cable Loss + Reading - Amp Factor
 2. The emission levels that are 20dB below the official limit are not reported.

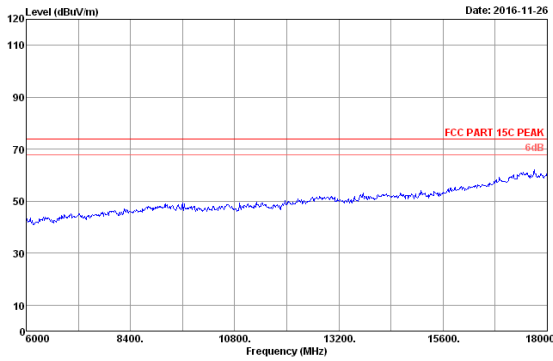

Site no. : 3m Chamber Data no. : 111
 Dis. / Ant. : 3m 2016 MCTD1209 3007 Ant. pol. : HORIZONTAL
 Limit : FCC PART 15C PEAK Pre : 101.2kPa
 Env. / Ins. : 23.1kV/54.9kV Engineer : Lynn
 EUT : CaptionCall Wireless Router 2
 Power rating : DC 9V From Adapter Input AC 120V/60Hz
 Test Mode : IEEE802.11ac VHT40 5230MHz Tx Mode
 M/N:CR2

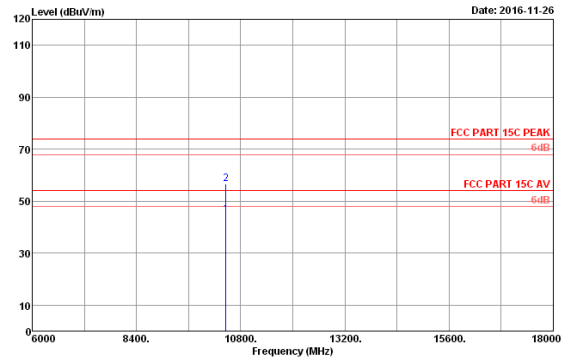

Site no. : 3m Chamber Data no. : 112
 Dis. / Ant. : 3m 2016 MCTD1209 3007 Ant. pol. : HORIZONTAL
 Limit : FCC PART 15C PEAK Pre : 101.2kPa
 Env. / Ins. : 23.1kV/54.9kV Engineer : Lynn
 EUT : CaptionCall Wireless Router 2
 Power rating : DC 9V From Adapter Input AC 120V/60Hz
 Test Mode : IEEE802.11ac VHT40 5230MHz Tx Mode
 M/N:CR2

No.	Freq. (MHz)	Ant. Factor (dB/m)	Cable Loss (dB)	Reading (dBuV)	AMP factor (dB)	Emission Level (dBuV/m)	Limits (dBuV/m)	Margin (dB)	Remark
1	10460.00	38.36	13.37	29.40	36.31	44.82	54.00	9.18	Average
2	10460.00	38.36	13.37	41.27	36.31	56.69	74.00	17.31	Peak

Remarks: 1. Emission Level= Antenna Factor + Cable Loss + Reading - Amp Factor
 2. The emission levels that are 20dB below the official limit are not reported.

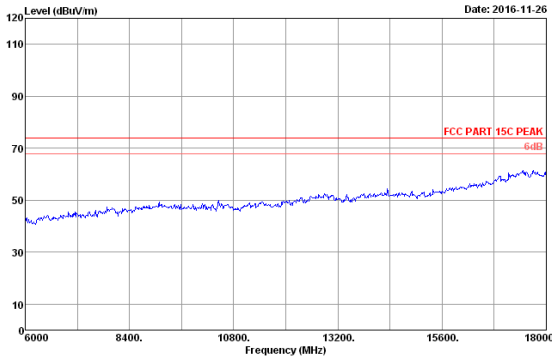

Date: 2016-11-26
 Site no. : 3m Chamber Data no. : 113
 Dis. / Ant. : 3m 2016 MCTD1209 3007 Ant. pol. : VERTICAL
 Limit : FCC PART 15C PEAK Pre : 101.2kPa
 Env. / Ins. : 23.1kV/54.9kV Engineer : Lynn
 EUT : CaptionCall Wireless Router 2
 Power rating : DC 9V From Adapter Input AC 120V/60Hz
 Test Mode : IEEE802.11ac VHT40 5230MHz Tx Mode
 M/N:CR2

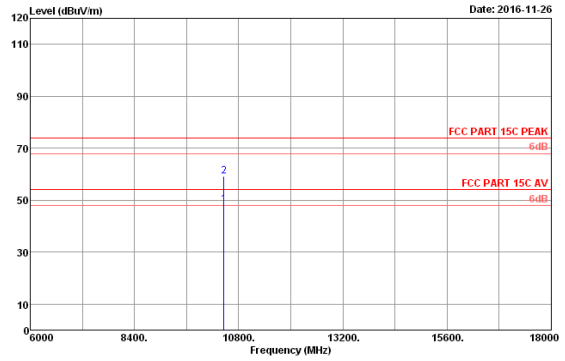

Date: 2016-11-26
 Site no. : 3m Chamber Data no. : 114
 Dis. / Ant. : 3m 2016 MCTD1209 3007 Ant. pol. : VERTICAL
 Limit : FCC PART 15C PEAK Pre : 101.2kPa
 Env. / Ins. : 23.1kV/54.9kV Engineer : Lynn
 EUT : CaptionCall Wireless Router 2
 Power rating : DC 9V From Adapter Input AC 120V/60Hz
 Test Mode : IEEE802.11ac VHT40 5230MHz Tx Mode
 M/N:CR2

No.	Freq. (MHz)	Ant. Factor (dB/m)	Cable Loss (dB)	Reading (dBuV)	AMP factor (dB)	Emission Level (dBuV/m)	Limits (dBuV/m)	Margin (dB)	Remark
1	10460.00	38.36	13.37	32.84	36.31	48.26	54.00	5.74	Average
2	10460.00	38.36	13.37	43.88	36.31	59.30	74.00	14.70	Peak

Remarks: 1. Emission Level= Antenna Factor + Cable Loss + Reading -AMP Factor
 2. The emission levels that are 20dB below the official limit are not reported.

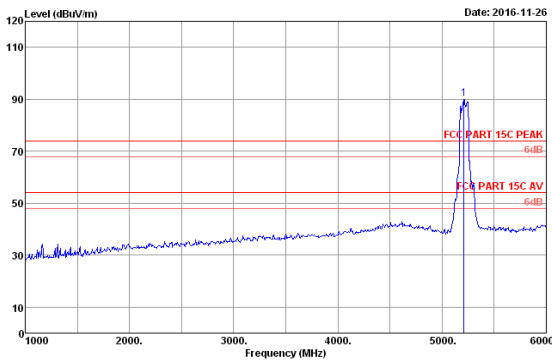

Date: 2016-11-26
 Site no. : 3m Chamber Data no. : 119
 Dis. / Ant. : 3m 2016 MCTD1209 3007 Ant. pol. : HORIZONTAL
 Limit : FCC PART 15C PEAK Pre : 101.2kPa
 Env. / Ins. : 23.1kV/54.9kV Engineer : Lynn
 EUT : CaptionCall Wireless Router 2
 Power rating : DC 9V From Adapter Input AC 120V/60Hz
 Test Mode : IEEE802.11ac VHT80 5210MHz Tx Mode
 M/N:CR2

No.	Freq. (MHz)	Ant. Factor (dB/m)	Cable Loss (dB)	Reading (dBuV)	AMP factor (dB)	Emission Level (dBuV/m)	Limits (dBuV/m)	Margin (dB)	Remark
1	5210.00	32.40	11.91	81.67	35.61	90.37	74.00	-16.37	Peak

Remarks: 1. Emission Level= Antenna Factor + Cable Loss + Reading -AMP Factor
 2. The emission levels that are 20dB below the official limit are not reported.

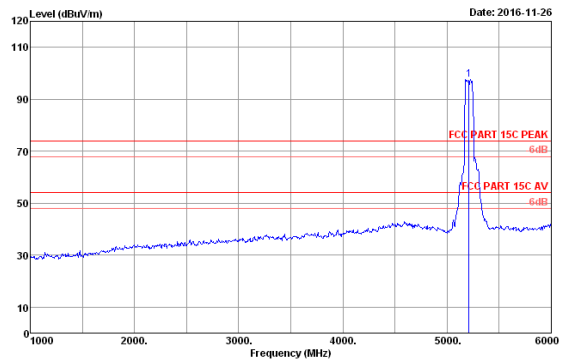

Date: 2016-11-26
 Site no. : 3m Chamber Data no. : 120
 Dis. / Ant. : 3m 2016 MCTD1209 3007 Ant. pol. : VERTICAL
 Limit : FCC PART 15C PEAK Pre : 101.2kPa
 Env. / Ins. : 23.1kV/54.9kV Engineer : Lynn
 EUT : CaptionCall Wireless Router 2
 Power rating : DC 9V From Adapter Input AC 120V/60Hz
 Test Mode : IEEE802.11ac VHT80 5210MHz Tx Mode
 M/N:CR2

No.	Freq. (MHz)	Ant. Factor (dB/m)	Cable Loss (dB)	Reading (dBuV)	AMP factor (dB)	Emission Level (dBuV/m)	Limits (dBuV/m)	Margin (dB)	Remark
1	5210.00	32.40	11.91	88.96	35.61	97.66	74.00	-23.66	Peak

Remarks: 1. Emission Level= Antenna Factor + Cable Loss + Reading -AMP Factor
 2. The emission levels that are 20dB below the official limit are not reported.

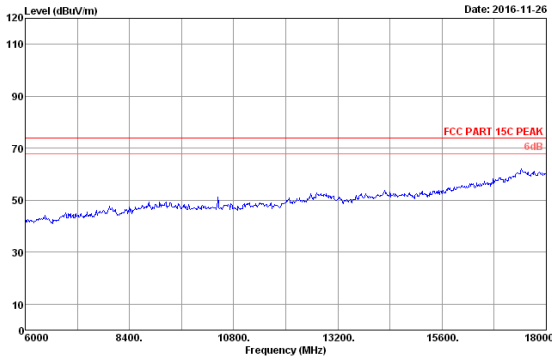

Site no. : 3m Chamber Data no. : 121
 Dis. / Ant. : 3m 2016 MCTD1209 3007 Ant. pol. : VERTICAL
 Limit : FCC PART 15C PEAK Pre : 101.2kPa
 Env. / Ins. : 23.1kV/54.9kV Engineer : Lynn
 EUT : CaptionCall Wireless Router 2
 Power rating : DC 9V From Adapter Input AC 120V/60Hz
 Test Mode : IEEE802.11ac VHT80 S210MHz Tx Mode
 M/N:CR2

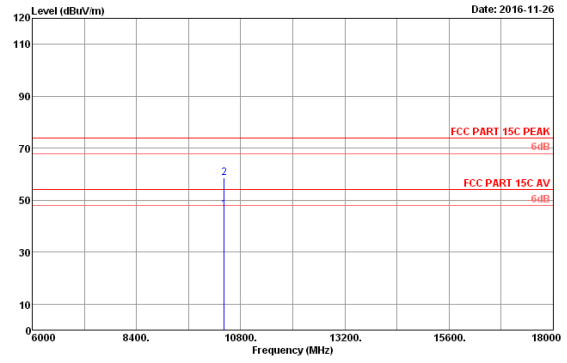

Site no. : 3m Chamber Data no. : 122
 Dis. / Ant. : 3m 2016 MCTD1209 3007 Ant. pol. : VERTICAL
 Limit : FCC PART 15C PEAK Pre : 101.2kPa
 Env. / Ins. : 23.1kV/54.9kV Engineer : Lynn
 EUT : CaptionCall Wireless Router 2
 Power rating : DC 9V From Adapter Input AC 120V/60Hz
 Test Mode : IEEE802.11ac VHT80 S210MHz Tx Mode
 M/N:CR2

No.	Freq. (MHz)	Ant. Factor (dB/m)	Cable Loss (dB)	Reading (dBuV)	AMP factor (dB)	Emission Level (dBuV/m)	Limits (dBuV/m)	Margin (dB)	Remark
1	10420.00	38.32	13.36	31.18	36.31	46.55	54.00	7.45	Average
2	10420.00	38.32	13.36	43.28	36.31	58.65	74.00	15.35	Peak

Remarks: 1. Emission Level= Antenna Factor + Cable Loss + Reading - Amp Factor
 2. The emission levels that are 20dB below the official limit are not reported.

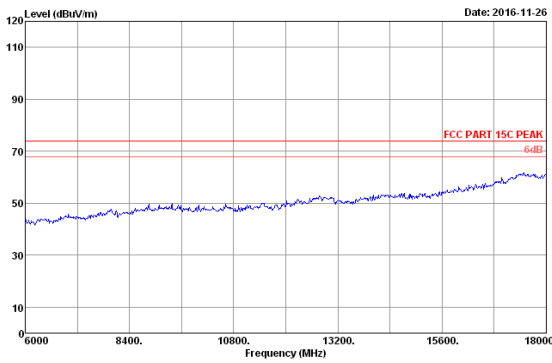

Site no. : 3m Chamber Data no. : 123
 Dis. / Ant. : 3m 2016 MCTD1209 3007 Ant. pol. : HORIZONTAL
 Limit : FCC PART 15C PEAK Pre : 101.2kPa
 Env. / Ins. : 23.1kV/54.9kV Engineer : Lynn
 EUT : CaptionCall Wireless Router 2
 Power rating : DC 9V From Adapter Input AC 120V/60Hz
 Test Mode : IEEE802.11ac VHT80 S210MHz Tx Mode
 M/N:CR2

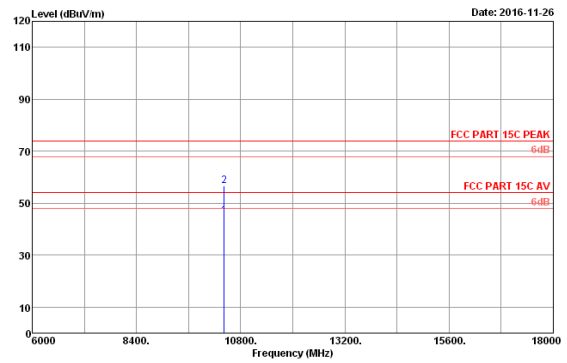

Site no. : 3m Chamber Data no. : 124
 Dis. / Ant. : 3m 2016 MCTD1209 3007 Ant. pol. : HORIZONTAL
 Limit : FCC PART 15C PEAK Pre : 101.2kPa
 Env. / Ins. : 23.1kV/54.9kV Engineer : Lynn
 EUT : CaptionCall Wireless Router 2
 Power rating : DC 9V From Adapter Input AC 120V/60Hz
 Test Mode : IEEE802.11ac VHT80 S210MHz Tx Mode
 M/N:CR2

No.	Freq. (MHz)	Ant. Factor (dB/m)	Cable Loss (dB)	Reading (dBuV)	AMP factor (dB)	Emission Level (dBuV/m)	Limits (dBuV/m)	Margin (dB)	Remark
1	10420.00	38.32	13.36	29.67	36.31	45.04	54.00	8.96	Average
2	10420.00	38.32	13.36	41.22	36.31	56.59	74.00	17.41	Peak

Remarks: 1. Emission Level= Antenna Factor + Cable Loss + Reading - Amp Factor
 2. The emission levels that are 20dB below the official limit are not reported.

5745-5825MHz Band:
Frequency: 30MHz~1GHz

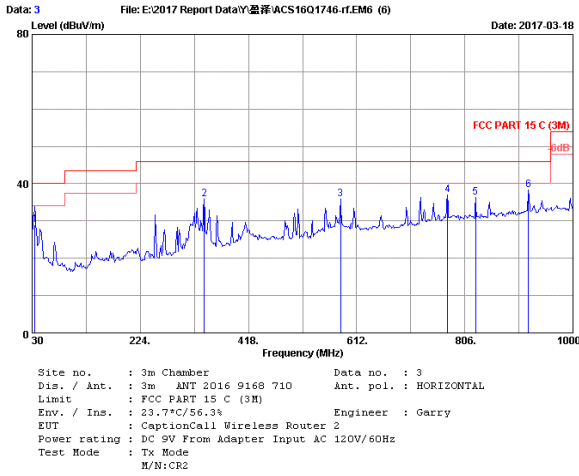

No.	Freq. (MHz)	Ant. Factor (dB/m)	Cable Loss (dB)	Reading (dBuV)	Emission Level (dBuV/m)	Limits (dBuV/m)	Margin (dB)	Remark
1	34.850	19.47	0.64	8.82	28.93	40.00	11.07	QP
2	338.460	20.09	2.16	12.88	35.93	46.00	10.07	QP
3	582.900	25.47	3.06	7.32	35.85	46.00	10.15	QP
4	774.960	28.15	3.87	5.07	37.09	46.00	8.91	QP
5	825.400	28.42	4.08	3.77	36.27	46.00	9.73	QP
6	920.460	29.65	4.39	4.18	38.22	46.00	7.78	QP

Remarks: 1. Emission Level= Antenna Factor + Cable Loss + Reading.
 2. The emission levels that are 20dB below the official limit are not reported.

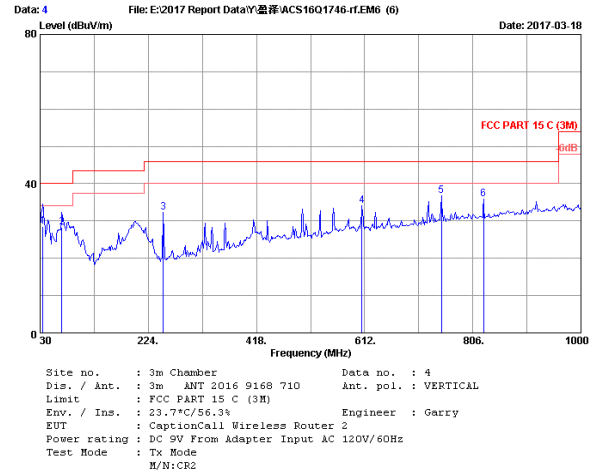

No.	Freq. (MHz)	Ant. Factor (dB/m)	Cable Loss (dB)	Reading (dBuV)	Emission Level (dBuV/m)	Limits (dBuV/m)	Margin (dB)	Remark
1	34.850	19.47	0.64	8.41	28.52	40.00	11.48	QP
2	66.800	18.03	1.03	9.24	28.30	40.00	11.70	QP
3	251.160	18.30	1.51	12.58	32.39	46.00	13.61	QP
4	607.150	26.16	3.15	4.82	34.13	46.00	11.87	QP
5	749.740	27.83	3.76	5.08	36.67	46.00	9.33	QP
6	825.400	28.42	4.08	3.36	35.86	46.00	10.14	QP

Remarks: 1. Emission Level= Antenna Factor + Cable Loss + Reading.
 2. The emission levels that are 20dB below the official limit are not reported.