



FCC PART 15C TEST REPORT FOR CERTIFICATION

On Behalf of

CaptionCall, LLC

CaptionCall Wireless Router 2

CR2

FCC ID: 2AA6ZCR2

Prepared for : CaptionCall, LLC
4215 South Riverboat Road, Salt Lake City, UT 84123. USA.

Prepared By : Audix Technology (Shenzhen) Co., Ltd.
No. 6, Kefeng Road, Science & Technology Park,
Nanshan District , Shenzhen, Guangdong, China

Tel: (0755) 26639496

Report Number : ACS-F16152
Date of Test : Nov.24, 2016~Mar.18, 2017
Date of Report : Apr.18, 2017

TABLE OF CONTENTS

Description	Page
1. SUMMARY OF STANDARDS AND RESULTS	1-1
1.1. Description of Standards and Results	1-1
2. GENERAL INFORMATION	2-1
2.1. Description of Device (EUT)	2-1
2.2. Test Information	2-2
2.1. Tested Supporting System Details	2-3
2.2. Block diagram of connection between the EUT and simulators	2-3
2.3. Test Facility	2-4
2.4. Measurement Uncertainty (95% confidence levels, k=2)	2-4
3. POWER LINE CONDUCTED EMISSION TEST	3-1
3.1. Test Equipments	3-1
3.2. Block Diagram of Test Setup	3-1
3.3. Power Line Conducted Emission Test Limits	3-1
3.4. Configuration of EUT on Test	3-2
3.5. Operating Condition of EUT	3-2
3.6. Test Procedure	3-2
3.7. Power Line Conducted Emission Test Results	3-2
4. RADIATED EMISSION TEST	4-1
4.1. Test Equipment	4-1
4.2. Block Diagram of Test Setup	4-2
4.3. Radiated Emission Limit	4-3
4.4. EUT Configuration on Test	4-3
4.5. Operating Condition of EUT	4-4
4.6. Test Procedure	4-4
4.7. Radiated Emission Test Results	4-4
5. CONDUCTED SPURIOUS EMISSIONS	5-1
5.1. Test Equipment	5-1
5.2. Limit	5-1
5.3. Test Procedure	5-1
5.4. Test result	5-1
6. BAND EDGE COMPLIANCE TEST	6-1
6.1. Test Equipment	6-1
6.2. Limit	6-1
6.3. Test Produce	6-1
6.4. Test Results	6-1
7. 6dB Bandwidth Test	7-1
7.1. Test Equipment	7-1
7.2. Limit	7-1
7.3. Test Procedure	7-1
7.4. Test Results	7-1
8. OUTPUT POWER TEST	8-1
8.1. Test Equipment	8-1
8.2. Limit (FCC Part 15C 15.247 b(3))	8-1
8.3. Test Procedure	8-1
8.4. Test Results	8-2
9. POWER SPECTRAL DENSITY TEST	9-1

9.1.	Test Equipment.....	9-1
9.2.	Limit	9-1
9.3.	Test Procedure.....	9-1
9.4.	Test Results	9-2
10.	MPE ESTIMATION	10-1
10.1.	Limit for General Population/ Uncontrolled Exposures	10-1
10.2.	Estimation Result	10-1
11.	ANTENNA REQUIREMENT	11-2
11.1.	Standard Applicable	11-2
11.2.	Antenna Connected Construction.....	11-2
12.	DEVIATION TO TEST SPECIFICATIONS	12-1
13.	PHOTOGRAPH OF TEST	13-1
13.1.	Photos of Power Line Conducted Emission Test.....	13-1
13.2.	Photos of Radiated Emission Test.....	13-2
14.	PHOTOGRAPHS OF EUT.....	14-1

TEST REPORT CERTIFICATION

Applicant : CaptionCall, LLC
 Manufacturer : HUNAN FULLRIVER HIGH TECHNOLOGY CO., LTD.
 Product : CaptionCall Wireless Router 2
 FCC ID : 2AA6ZCR2
 (A) Model No. : CR2
 (B) Power Supply : DC 9V
 (C) Test Voltage : DC 9V From Adapter Input AC 120V/60Hz

Tested for comply with:
 FCC CFR 47 Part 15 Subpart C

Test procedure used:
 ANSI C63.10: 2013
 KDB558074 D01 v03r03

The device described above is tested by AUDIX TECHNOLOGY (SHENZHEN) CO., LTD. to confirm comply with all the FCC Part 15 Subpart C requirements. The test results are contained in this test report and AUDIX TECHNOLOGY (SHENZHEN) CO., LTD. is assumed full responsibility for the accuracy and completeness of these tests. Also, this report shows that the Equipment Under Test (EUT) is to be technically compliant with the FCC and IC requirements. This report contains data that are not covered by the NVLAP accreditation.

This Report is made under FCC Part 2.1075. No modifications were required during testing to bring this product into compliance.

This report applies to above tested sample only. This report shall not be reproduced in part without written approval of AUDIX TECHNOLOGY (SHENZHEN) CO., LTD.

The report must not be used by the client to claim product certification, approval, or endorsement by NVLAP, NIST, or any agency of the federal government.

Date of Test : Nov.24, 2016~Mar.18, 2017 Report of date: Apr.18, 2017

Prepared by : Monica Liu Reviewed by : Sunny Lu
 Monica Liu / Assistant Sunny Lu / Deputy Manager



Approved & Authorized Signer : David Jin
 David Jin / Manager

1. SUMMARY OF STANDARDS AND RESULTS

1.1. Description of Standards and Results

The EUT has been tested according to the applicable standards as referenced below.

EMISSION		
Description of Test Item	Standard	Results
Power Line Conducted Emission	FCC Part 15: 15.207	PASS
Radiated Emission	FCC Part 15: 15.209	PASS
Band Edge Compliance	FCC Part 15: 15.247	PASS
Conducted spurious emissions	FCC Part 15: 15.247	PASS
6dB Bandwidth	FCC Part 15: 15.247	PASS
Peak Output Power	FCC Part 15: 15.247	PASS
Power Spectral Density	FCC Part 15: 15.247	PASS
MPE Estimation	FCC Part 15: 15.247	PASS
Antenna requirement	FCC Part 15: 15.203	PASS

N/A is an abbreviation for Not Applicable.

2. GENERAL INFORMATION

2.1. Description of Device (EUT)

Product	: CaptionCall Wireless Router 2
Model No.	: CR2
FCC ID	: 2AA6ZCR2
Radio	: IEEE802.11 a/b/g/n/ac
Operation Frequency	: IEEE 802.11a: 5180MHz—5240MHz; 5745MHz—5825MHz IEEE 802.11ac VHT20: 5180MHz—5240MHz; 5745MHz—5825MHz IEEE 802.11ac VHT40: 5190MHz—5230MHz; 5755MHz—5795MHz IEEE 802.11ac VHT80: 5210MHz; 5775MHz IEEE 802.11b: 2412MHz—2462MHz IEEE 802.11g: 2412MHz—2462MHz IEEE802.11nHT20: 2412MHz—2462MHz; 5180MHz—5240MHz; 5745MHz—5825MHz IEEE802.11nHT40: 2422MHz—2452MHz; 5190MHz—5230MHz; 5755MHz—5795MHz
Modulation Technology	: IEEE 802.11b: DSSS(CCK,DQPSK,DBPSK) IEEE 802.11a/g: OFDM(64QAM, 16QAM, QPSK, BPSK) IEEE 802.11ac VHT20, VHT40, VHT80: OFDM(16QAM, 64QAM, 256QAM, QPSK, BPSK) IEEE 802.11n HT20, HT40: OFDM (64QAM, 16QAM,QPSK,BPSK)
Antenna Assembly Gain	: Antenna Type: PCBA Antenna, WIFI 2.4GHz: ANT A: 2dBi gain; Antenna Type: Dipole Antenna, WIFI 2.4GHz: ANT B: 5dBi gain; WIFI 5GHz: ANT: 5dBi gain
Applicant	: CaptionCall, LLC 4215 South Riverboat Road, Salt Lake City, UT 84123. USA.
Manufacturer	: HUNAN FULLRIVER HIGH TECHNOLOGY CO., LTD. FullRiver Industrial Area Economic Development Zone LiLing City HuNan Province China
Factory	: HUNAN FULLRIVER HIGH TECHNOLOGY CO., LTD. FullRiver Industrial Area Economic Development Zone LiLing City HuNan Province China

Power Adapter : Manufacturer: AMIGO, M/N: AMS135-0901000FU
 Input: 100-240Vac; 50/60Hz, 0.5A
 Output: 9V; 1A
 DC Cable: Shielded, Undetachable, 1.5m

Date of Test : Nov.24, 2016~Mar.18, 2017

Date of Receipt : Nov.22, 2016

2.2. Test Information

A special test software was used to control EUT work in Continuous TX mode(nearly 100% duty cycle), and select test channel, wireless mode and data rate.

Tested mode, channel, and data rate information			
Mode	data rate (Mbps)(see Note)	Channel	Frequency (MHz)
IEEE 802.11b	1	Low :CH1	2412
	1	Middle: CH6	2437
	1	High: CH11	2462
IEEE 802.11g	6	Low :CH1	2412
	6	Middle: CH6	2437
	6	High: CH11	2462
IEEE 802.11n HT20	MCS0	Low :CH1	2412
	MCS0	Middle: CH6	2437
	MCS0	High: CH11	2462
IEEE 802.11n HT40	MCS0	Low :CH3	2422
	MCS0	Middle: CH6	2437
	MCS0	High: CH9	2452

Note: 1. According exploratory test, EUT will have maximum output power in those data rate, so those data rate were used for all test.
 Note: 2. 11b/g use SISO mode, choose ANT B which has the worse case emission for the radiated emission and band edge measurement, 11n mode use MIMO Mode, test with two antenna transmit simultaneously in 11n mode, and comply with KDB662911D01.

2.1. Tested Supporting System Details

No.	Description	ACS No.	Manufacturer	Model	Serial Number
1.	Notebook	N/A	DELL	PP09S	N/A
		Power Cord: Unshielded, Detachable, 1.8m Power Adapter: Manufacturer: DELL, M/N: LA65NS1-00 Cable: Unshielded, Detachable, 4.0m(Bond one ferrite core)			
2.	LAN Cable	Unshielded, Detachable, 15m			

2.2. Block diagram of connection between the EUT and simulators

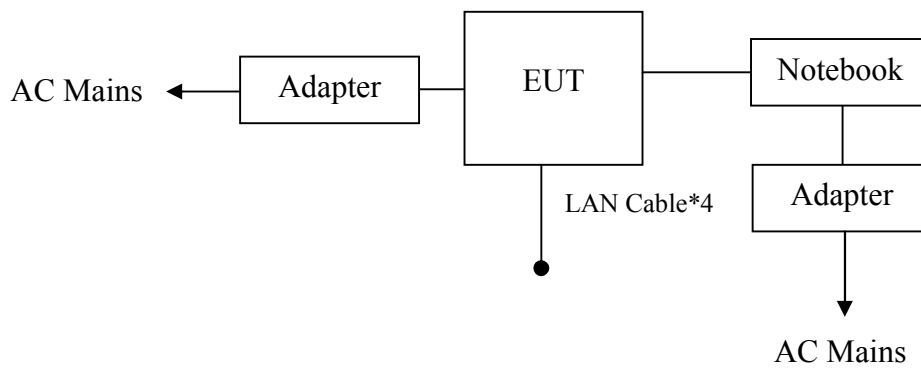

(EUT: CaptionCall Wireless Router 2)

2.3. Test Facility

Site Description

Name of Firm	:	Audix Technology (Shenzhen) Co., Ltd. No. 6, Ke Feng Rd., 52 Block, Shenzhen Science & Industrial Park, Nantou, Shenzhen, Guangdong, China
3m Anechoic Chamber	:	Certificated by FCC, USA Registration Number: 90454 Valid Date: Jul.12, 2017
3m & 10m Anechoic Chamber	:	Certificated by FCC, USA Registration Number: 794232 Valid Date: Jul.12, 2017
EMC Lab.	:	Certificated by Industry Canada Registration Number: IC 5183A-1 Valid Date: May.14, 2017
	:	Certificated by DAkkS, Germany Registration No: D-PL-12151-01-00 Valid Date: Dec.07, 2021
	:	Accredited by NVLAP, USA NVLAP Code: 200372-0 Valid Date: Mar.31, 2018

2.4.Measurement Uncertainty (95% confidence levels, k=2)

Test Item	Uncertainty
Uncertainty for Conduction emission test in No. 1 Conduction	3.2dB (150kHz to 30MHz)
Uncertainty for Radiation Emission test in 3m chamber	2.8dB(30~200MHz, Polarization: H)
	2.8dB(30~200MHz, Polarization: V)
	3.0dB(200M~1GHz, Polarization: H)
	3.0dB(200M~1GHz, Polarization: V)
Uncertainty for Radiation Emission test in 3m chamber (1GHz-18GHz)	5.8dB(1~6GHz, Distance: 3m)
	5.8dB(6~18GHz, Distance: 3m)
Uncertainty for Radiated Spurious Emission test in RF chamber	3.6dB
Uncertainty for Conduction Spurious emission test	2.0dB
Uncertainty for Output power test	0.8dB
Uncertainty for Bandwidth test	83kHz
Uncertainty for DC power test	0.1 %
Uncertainty for test site temperature and humidity	0.6°C
	3%

3. POWER LINE CONDUCTED EMISSION TEST

3.1. Test Equipments

Item	Equipment	Manufacturer	Model No.	Serial No.	Last Cal.	Cal. Interval
1.	1# Shielding Room	AUDIX	N/A	N/A	Apr.17,16	1 Year
2.	Test Receiver	Rohde & Schwarz	ESCI	100842	Apr.24,16	1 Year
3.	L.I.S.N.#1	Rohde & Schwarz	ESH2-Z5	100429	Oct.15,16	1 Year
4.	L.I.S.N.#2	Kyoritsu	K NW-403D	8-1750-2	Apr.24,16	1 Year
5.	Terminator	Hubersuhner	50Ω	No.1	May.05.16	1 Year
6.	Terminator	Hubersuhner	50Ω	No.2	May.05.16	1 Year
7.	RF Cable	MIYAZAKI	3D-2W	No.1	Apr.24,16	1Year
8.	Coaxial Switch	Anritsu	MP59B	6200766906	Apr.23,16	1 Year
9.	Test Software	AUDIX	e3	6.100913a	N/A	N/A

Note: N/A means Not applicable.

3.2. Block Diagram of Test Setup

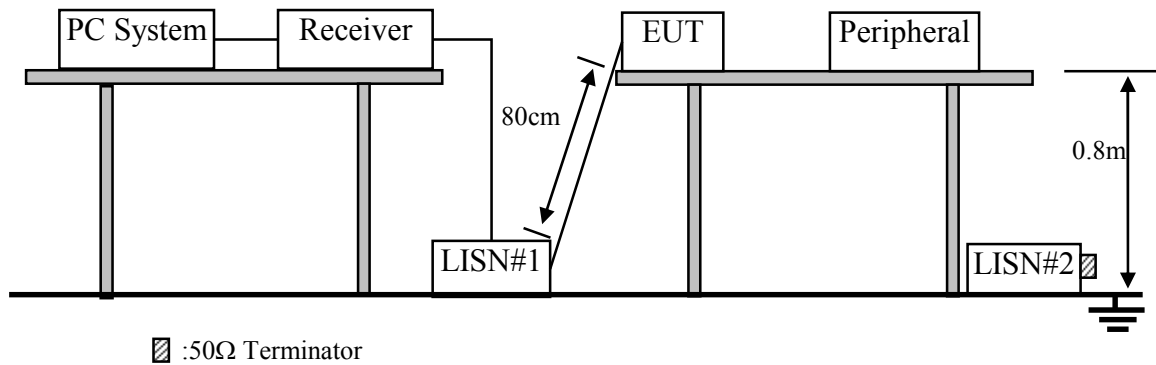

3.3. Power Line Conducted Emission Test Limits

Frequency	Maximum RF Line Voltage	
	Quasi-Peak Level dB(μV)	Average Level dB(μV)
150kHz ~ 500kHz	66 ~ 56*	56 ~ 46*
500kHz ~ 5MHz	56	46
5MHz ~ 30MHz	60	50

Notes: 1. * Decreasing linearly with logarithm of frequency.

2. The lower limit shall apply at the transition frequencies.

3.4. Configuration of EUT on Test

The following equipment are installed on Power Line Conducted Emission Test to meet the commission requirement and operating regulations in a manner which tends to maximize its emission characteristics in a normal application.

3.4.1. CaptionCall Wireless Router 2 (EUT)

Model No. : CR2
Serial No. : N/A

3.4.2. Support Equipment: As Tested Supporting System Details, in Section 2.2.

3.5. Operating Condition of EUT

3.5.1. Setup the EUT and simulator as shown as Section 3.2.

3.5.2. Turn on the power of all equipments.

3.5.3. PC run test software to control EUT work in Tx (WiFi 2.4GHz) mode.

3.6. Test Procedure

The EUT was placed on a non-metallic table, 80cm above the ground plane. The EUT Power Via PC connected to the power mains through a line impedance stabilization network (L.I.S.N. 1#). This provides a 50 ohm coupling impedance for the EUT (Please refer the block diagram of the test setup and photographs). The AC line are checked to find out the maximum conducted emission. In order to find the maximum emission levels, the relative positions of equipment and all of the interface cables shall be changed according to ANSI C63.10: 2013 on Conducted Emission Test.

The bandwidth of test receiver (R & S ESCI) is set at 9kHz.

The frequency range from 150kHz to 30MHz is checked.

3.7. Power Line Conducted Emission Test Results

PASS. (All emissions not reported below are too low against the prescribed limits.)

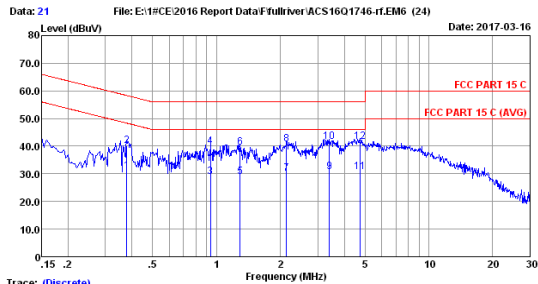

Trace: (Discrete)
 Site no :1# Conduction
 Dis./Lisn :2016 ESH2-25 LINE
 Limit :FCC PART 15 C
 Env./Ins. :22.5°C/53% Engineer :Evan
 EUT :CaptionCall Wireless Router 2
 Power Rating :DC 9V From Adapter Input AC 120V/60Hz
 Test Mode :TX Mode
 M/N:CR2

No	Freq (MHz)	LISN Factor (dB)	Cable Loss (dB)	Reading (dBuV)	Emission Level (dBuV)	Limits (dBuV)	Margin (dB)	Remark
1	0.377	0.13	0.03	30.93	31.09	48.34	17.25	Average
2	0.377	0.13	0.03	40.03	40.19	58.34	18.15	QP
3	0.938	0.17	0.06	28.58	28.81	46.00	17.19	Average
4	0.938	0.17	0.06	39.56	39.79	56.00	16.21	QP
5	1.289	0.19	0.07	28.71	28.97	46.00	17.03	Average
6	1.289	0.19	0.07	39.26	39.52	56.00	16.48	QP
7	2.133	0.20	0.08	29.82	30.10	46.00	15.90	Average
8	2.133	0.20	0.08	40.52	40.80	56.00	15.20	QP
9	3.399	0.22	0.08	30.52	30.82	46.00	15.18	Average
10	3.399	0.22	0.08	41.36	41.66	56.00	14.34	QP
11	4.746	0.25	0.09	30.27	30.61	46.00	15.39	Average
12	4.746	0.25	0.09	41.40	41.74	56.00	14.26	QP

Remarks: 1.Emission Level=LISN Factor+Cable Loss+Reading.
 2.If the average limit is met when using a quasi-peak detector, the EUT shall be deemed to meet both limits and measurement with average detector is unnecessary.

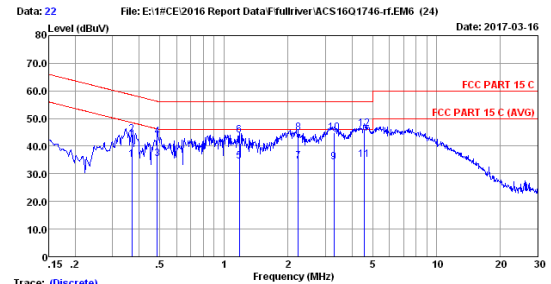

Trace: (Discrete)
 Site no :1# Conduction
 Dis./Lisn :2016 ESH2-25 NEUTRAL
 Limit :FCC PART 15 C
 Env./Ins. :22.5°C/53% Engineer :Evan
 EUT :CaptionCall Wireless Router 2
 Power Rating :DC 9V From Adapter Input AC 120V/60Hz
 Test Mode :TX Mode
 M/N:CR2

No	Freq (MHz)	LISN Factor (dB)	Cable Loss (dB)	Reading (dBuV)	Emission Level (dBuV)	Limits (dBuV)	Margin (dB)	Remark
1	0.369	0.15	0.03	34.82	35.00	48.52	13.52	Average
2	0.369	0.15	0.03	44.24	44.42	58.52	14.10	QP
3	0.486	0.15	0.03	35.28	35.46	46.23	10.77	Average
4	0.486	0.15	0.03	43.23	43.41	56.23	12.82	QP
5	1.194	0.19	0.07	34.15	34.41	46.00	11.59	Average
6	1.194	0.19	0.07	43.87	44.13	56.00	11.87	QP
7	2.237	0.20	0.08	34.25	34.53	46.00	11.47	Average
8	2.237	0.20	0.08	44.58	44.86	56.00	11.14	QP
9	3.293	0.22	0.08	33.82	34.12	46.00	11.88	Average
10	3.293	0.22	0.08	44.58	44.88	56.00	11.12	QP
11	4.574	0.26	0.09	34.69	35.04	46.00	10.96	Average
12	4.574	0.26	0.09	45.86	46.21	56.00	9.79	QP

Remarks: 1.Emission Level=LISN Factor+Cable Loss+Reading.
 2.If the average limit is met when using a quasi-peak detector, the EUT shall be deemed to meet both limits and measurement with average detector is unnecessary.

4. RADIATED EMISSION TEST

4.1. Test Equipment

4.1.1. For frequency range 30MHz~1000MHz (In 3m Anechoic Chamber)

Item	Equipment	Manufacturer	Model No.	Serial No.	Last Cal.	Cal. Interval
1.	3#Chamber	AUDIX	N/A	N/A	Mar.28,17	1 Year
2.	Spectrum Analyzer	Agilent	N9010A	MY52220804	Oct.15,16	1 Year
3.	EMI Test Receiver	Rohde & Schwarz	ESR7	101547	Apr.24,16	1 Year
4.	Amplifier	HP	8447D	2648A04738	Apr.24,16	1 Year
5.	Tri-log-Broadband Antenna	SCHWARZBECK	VULB 9168	9168-710	Jul.20,16	1 Year
6.	RF Cable	MIYAZAKI	CFD400NL-LW	No.3	Sep.26.16	1 Year
7.	Coaxial Switch	Anritsu	MP59B	6201397222	Apr.23,16	1 Year
8.	Attenuator	EMCI	EMCI-N-6-06	AT-N0639	Sep.26.16	1 Year
9.	Test Software	AUDIX	e3	6.2009-5-21a(n)	N/A	N/A

Note: N/A means Not applicable.

4.1.2. For frequency range 1GHz~40GHz (In 3m Anechoic Chamber)

Item	Equipment	Manufacturer	Model No.	Serial No.	Last Cal.	Cal. Interval
1.	3#Chamber	AUDIX	N/A	N/A	May.21,16	1 Year
2.	Spectrum Analyzer	Agilent	N9010A	MY52220804	Oct.15,16	1 Year
3.	Horn Antenna	ETC	MCTD 1209	DRH15F03007	Apr.11,16	1 Year
4.	Amplifier	Agilent	83017A	MY53270084	May.17,16	1 Year
5.	RF Cable	Hubersuhner	SUCOFLEX106	505238/6	Apr.24,16	1 Year
6.	Horn Antenna	ETS	3116	00060089	Nov.16,16	1 Year
7.	Test Software	AUDIX	e3	6.2009-5-21a(n)	N/A	N/A

Note: N/A means Not applicable.

4.2. Block Diagram of Test Setup

For frequency range 30MHz-1000MHz

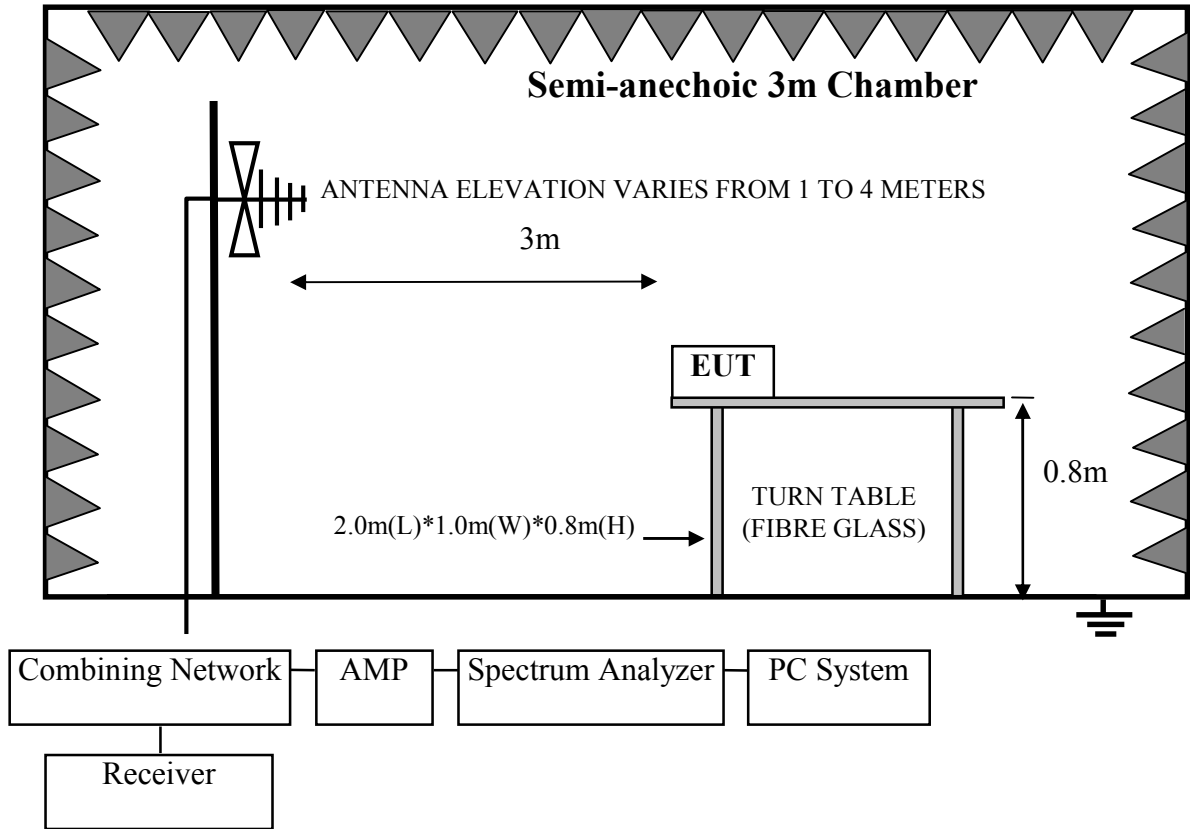

For frequency range 1GHz-25GHz

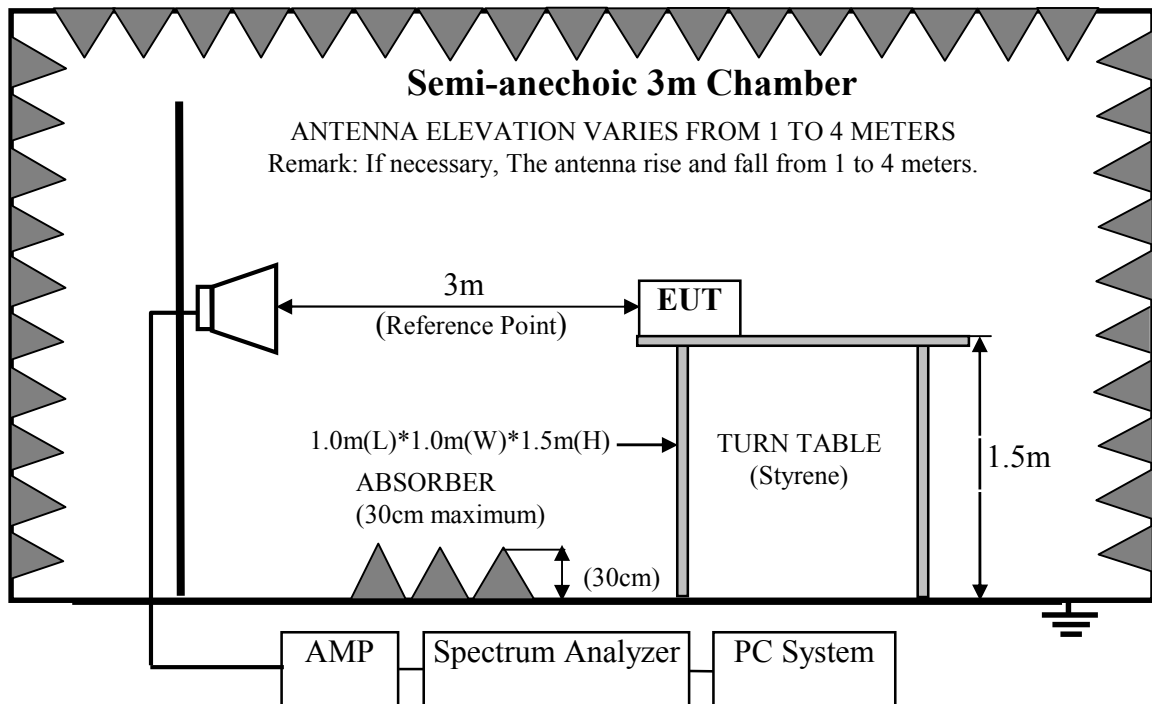

4.3. Radiated Emission Limit

4.3.1. 15.247&209 limits

FREQUENCY MHz	DISTANCE Meters	FIELD STRENGTHS LIMIT	
		μV/m	dB(μV)/m
30 ~ 88	3	100	40.0
88 ~ 216	3	150	43.5
216 ~ 960	3	200	46.0
960 ~ 1000	3	500	54.0
Above 1000	3	74.0 dB(μV)/m (Peak) 54.0 dB(μV)/m (Average)	

Remark : (1) Emission level dBμV = 20 log Emission level μV/m

(2) The smaller limit shall apply at the cross point between two frequency bands.

(3) Distance is the distance in meters between the measuring instrument, antenna and the closest point of any part of the device or system.

4.3.2. 15.205 Restricted bands of operation

MHz	MHz	MHz	GHz
0.090 - 0.110	16.42 - 16.423	399.9 - 410	4.5 - 5.15
0.495 - 0.505	16.69475 - 16.69525	608 - 614	5.35 - 5.46
2.1735 - 2.1905	16.80425 - 16.80475	960 - 1240	7.25 - 7.75
4.125 - 4.128	25.5 - 25.67	1300 - 1427	8.025 - 8.5
4.17725 - 4.17775	37.5 - 38.25	1435 - 1626.5	9.0 - 9.2
4.20725 - 4.20775	73 - 74.6	1645.5 - 1646.5	9.3 - 9.5
6.215 - 6.218	74.8 - 75.2	1660 - 1710	10.6 - 12.7
6.26775 - 6.26825	108 - 121.94	1718.8 - 1722.2	13.25 - 13.4
6.31175 - 6.31225	123 - 138	2200 - 2300	14.47 - 14.5
8.291 - 8.294	149.9 - 150.05	2310 - 2390	15.35 - 16.2
8.362 - 8.366	156.52475 - 156.52525	2483.5 - 2500	17.7 - 21.4
8.37625 - 8.38675	156.7 - 156.9	2690 - 2900	22.01 - 23.12
8.41425 - 8.41475	162.0125 - 167.17	3260 - 3267	23.6 - 24.0
12.29 - 12.293	167.72 - 173.2	3332 - 3339	31.2 - 31.8
12.51975 - 12.52025	240 - 285	3345.8 - 3358	36.43 - 36.5
12.57675 - 12.57725	322 - 335.4	3600 - 4400	(²)

All the emissions appearing within 15.205 restricted frequency bands shall not exceed the limits shown in 15.209, all the other emissions shall be at least 20dB below the fundamental emissions, or comply with 15.209 limits.

4.4. EUT Configuration on Test

The following equipment are installed on Power Line Conducted Emission Test to meet the commission requirement and operating regulations in a manner which tends to maximize its emission characteristics in a normal application.

4.4.1. CaptionCall Wireless Router 2 (EUT)

Model No.: CR2

Serial No.: N/A

4.4.2. Support Equipment: As Tested Supporting System Details, in Section 2.2.

4.5. Operating Condition of EUT

- 4.5.1. Setup the EUT and simulator as shown as Section 4.2.
- 4.5.2. Turn on the power of all equipments.
- 4.5.3. Let EUT work in Tx(WiFi 2.4GHz) mode

4.6. Test Procedure

EUT and its simulators are placed on a turn table, which is 0.8 meter high above ground for frequency 30MHz~1000MHz, 1.5 meter high above ground for frequency above 1GHz and put the absorbing with 2.4m(L)*2.4m(W)*0.3m(H) on the ground. The turn table can rotate 360 degrees to determine the position of the maximum emission level. Power on the EUT and let it working in test mode, then test it. EUT is set 3 meters away from the receiving antenna, which is mounted on a antenna tower. The antenna can be moved up and down between 1 meter and 4 meters to find out the maximum emission level. Broadband antenna (calibrated bilog antenna) is used as receiving antenna for frequency 30MHz~1000MHz, and the Horn antenna is used as receiving antenna for frequency above 1GHz. Both horizontal and vertical polarization of the antenna are set on test.

This test was performed with EUT in X, Y, Z position, and the worse case was found when EUT in X position as test photo indicated.

The bandwidth of the EMI test receiver (R&S ESR7) is set at 120kHz for frequency range from 30MHz to 1000 MHz.

The bandwidth of the Spectrum's VBW is set at 3MHz and RBW is set at 1MHz for peak emissions measurement above 1GHz and 1MHz RBW, 10Hz VBW for average emissions measure above 1GHz

The frequency range from 30MHz to 10th harmonic (25GHz) are checked. and no any emissions were found from 18GHz to 25GHz, So the radiated emissions from 18GHz to 25GHz were not record.

4.7. Radiated Emission Test Results

PASS.

All the emissions from 30MHz to 25 GHz were comply with 15.209 limits.

Note: For emissions above 1GHz, if peak level comply with average limit, then the average level is deemed to comply with average limit.

Frequency: 30MHz~1GHz

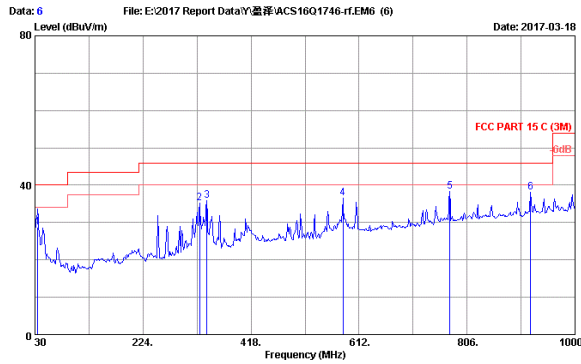

Site no. : 3m Chamber Data no. : 6
 Dis. / Ant. : 3m ANT 2016 9168 710 Ant. pol. : HORIZONTAL
 Limit : FCC PART 15 C (3M)
 Env. / Ins. : 23.7°C/56.3% Engineer : Garry
 EUT : CaptionCall Wireless Router 2
 Power rating : DC 9V From Adapter Input AC 120V/60Hz
 Test Mode : Tx Mode
 M/N:CR2

No.	Freq. (MHz)	Ant. Factor (dB/m)	Cable Loss (dB)	Reading (dBuV)	Emission Level (dBuV/m)	Limits (dBuV/m)	Margin (dB)	Remark
1	34.850	19.47	0.64	8.63	28.74	40.00	11.26	QP
2	325.850	20.60	2.11	12.46	35.17	46.00	10.83	QP
3	338.460	20.89	2.16	12.81	35.86	46.00	10.14	QP
4	582.900	25.47	3.06	7.99	36.52	46.00	9.48	QP
5	774.960	28.15	3.87	6.41	38.43	46.00	7.57	QP
6	920.460	29.65	4.39	4.13	38.17	46.00	7.83	QP

Remarks: 1. Emission Level= Antenna Factor + Cable Loss + Reading.
 2. The emission levels that are 20dB below the official limit are not reported.

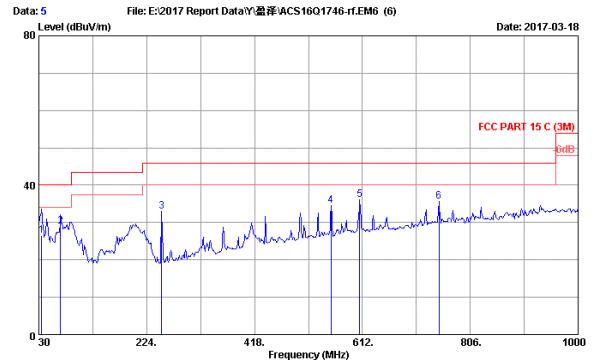

Site no. : 3m Chamber Data no. : 5
 Dis. / Ant. : 3m ANT 2016 9168 710 Ant. pol. : VERTICAL
 Limit : FCC PART 15 C (3M)
 Env. / Ins. : 23.7°C/56.3% Engineer : Garry
 EUT : CaptionCall Wireless Router 2
 Power rating : DC 9V From Adapter Input AC 120V/60Hz
 Test Mode : Tx Mode
 M/N:CR2

No.	Freq. (MHz)	Ant. Factor (dB/m)	Cable Loss (dB)	Reading (dBuV)	Emission Level (dBuV/m)	Limits (dBuV/m)	Margin (dB)	Remark
1	34.850	19.47	0.64	6.45	26.56	40.00	13.44	QP
2	68.800	18.03	1.03	9.95	29.01	40.00	10.99	QP
3	251.160	18.30	1.51	13.21	33.02	46.00	12.98	QP
4	585.740	24.89	2.95	6.73	34.57	46.00	11.43	QP
5	607.150	26.16	3.15	6.79	36.10	46.00	9.90	QP
6	749.740	27.83	3.76	4.10	35.69	46.00	10.31	QP

Remarks: 1. Emission Level= Antenna Factor + Cable Loss + Reading.
 2. The emission levels that are 20dB below the official limit are not reported.

Frequency: 1GHz~18GHz

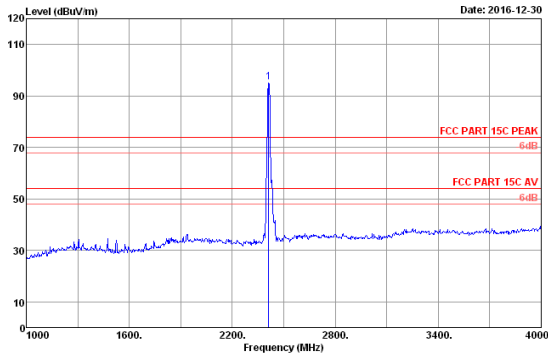

Site no. : 3m Chamber Data no. : 9
 Dis. / Ant. : 3m 2016 MCTD1209 3007 Ant. pol. : HORIZONTAL
 Limit : FCC PART 15C PEAK Pre : 101.2kPa
 Env. / Ins. : 23.1°C/54.9% Engineer : Lynn
 EUT : CaptionCall Wireless Router 2
 Power rating : DC 9V From Adapter Input AC 120W/60Hz
 Test Mode : IEEE802.11b 2412MHz Tx Mode
 M/N:CR2

No.	Freq. (MHz)	Ant. Factor (dB/m)	Cable Loss (dB)	Reading (dBuV)	AMP factor (dB)	Emission Level (dBuV/m)	Limits (dBuV/m)	Margin (dB)	Remark
1	2412.00	28.16	8.35	95.12	36.39	95.24	74.00	-21.24	Peak

Remarks: 1. Emission Level= Antenna Factor + Cable Loss + Reading - Amp Factor
 2. The emission levels that are 20dB below the official limit are not reported.

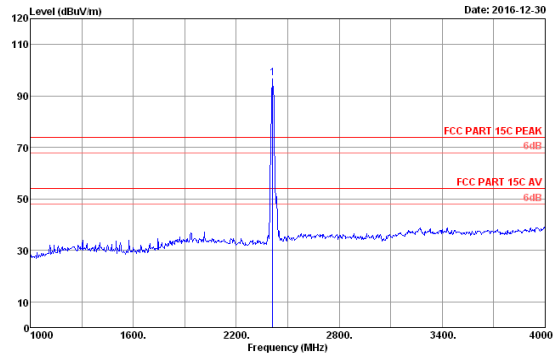

Site no. : 3m Chamber Data no. : 10
 Dis. / Ant. : 3m 2016 MCTD1209 3007 Ant. pol. : VERTICAL
 Limit : FCC PART 15C PEAK Pre : 101.2kPa
 Env. / Ins. : 23.1°C/54.9% Engineer : Lynn
 EUT : CaptionCall Wireless Router 2
 Power rating : DC 9V From Adapter Input AC 120W/60Hz
 Test Mode : IEEE802.11b 2412MHz Tx Mode
 M/N:CR2

No.	Freq. (MHz)	Ant. Factor (dB/m)	Cable Loss (dB)	Reading (dBuV)	AMP factor (dB)	Emission Level (dBuV/m)	Limits (dBuV/m)	Margin (dB)	Remark
1	2412.00	28.16	8.35	96.68	36.39	96.80	74.00	-22.80	Peak

Remarks: 1. Emission Level= Antenna Factor + Cable Loss + Reading - Amp Factor
 2. The emission levels that are 20dB below the official limit are not reported.

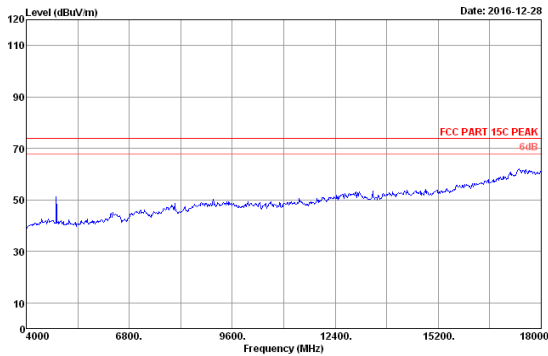

Site no. : 3m Chamber Data no. : 11
 Dis. / Ant. : 3m 2016 MCTD1209 3007 Ant. pol. : VERTICAL
 Limit : FCC PART 15C PEAK Pre : 101.2kPa
 Env. / Ins. : 23.1°C/54.9% Engineer : Lynn
 EUT : CaptionCall Wireless Router 2
 Power rating : DC 9V From Adapter Input AC 120W/60Hz
 Test Mode : IEEE802.11b 2412MHz Tx Mode
 M/N:CR2

No.	Freq. (MHz)	Ant. Factor (dB/m)	Cable Loss (dB)	Reading (dBuV)	AMP factor (dB)	Emission Level (dBuV/m)	Limits (dBuV/m)	Margin (dB)	Remark
1	4824.00	32.75	11.77	41.67	35.68	50.51	54.00	3.49	Average
2	4824.00	32.75	11.77	47.00	35.68	55.84	74.00	18.16	Peak

Remarks: 1. Emission Level= Antenna Factor + Cable Loss + Reading - Amp Factor
 2. The emission levels that are 20dB below the official limit are not reported.

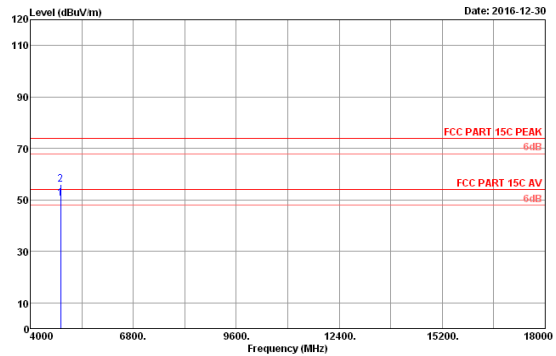

Site no. : 3m Chamber Data no. : 12
 Dis. / Ant. : 3m 2016 MCTD1209 3007 Ant. pol. : VERTICAL
 Limit : FCC PART 15C PEAK Pre : 101.2kPa
 Env. / Ins. : 23.1°C/54.9% Engineer : Lynn
 EUT : CaptionCall Wireless Router 2
 Power rating : DC 9V From Adapter Input AC 120W/60Hz
 Test Mode : IEEE802.11b 2412MHz Tx Mode
 M/N:CR2

No.	Freq. (MHz)	Ant. Factor (dB/m)	Cable Loss (dB)	Reading (dBuV)	AMP factor (dB)	Emission Level (dBuV/m)	Limits (dBuV/m)	Margin (dB)	Remark
1	4824.00	32.75	11.77	41.67	35.68	50.51	54.00	3.49	Average
2	4824.00	32.75	11.77	47.00	35.68	55.84	74.00	18.16	Peak

Remarks: 1. Emission Level= Antenna Factor + Cable Loss + Reading - Amp Factor
 2. The emission levels that are 20dB below the official limit are not reported.

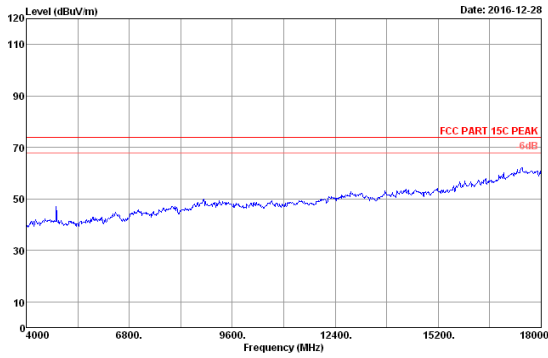

Site no. : 3m Chamber Data no. : 13
 Dis. / Ant. : 3m 2016 MCTD1209 3007 Ant. pol. : HORIZONTAL
 Limit : FCC PART 15C PEAK Pre : 101.2kPa
 Env. / Ins. : 23.1°C/54.9% Engineer : Lynn
 EUT : CaptionCall Wireless Router 2
 Power rating : DC 9V From Adapter Input AC 120W/60Hz
 Test Mode : IEEE802.11b 2412MHz Tx Mode
 N/N:CR2

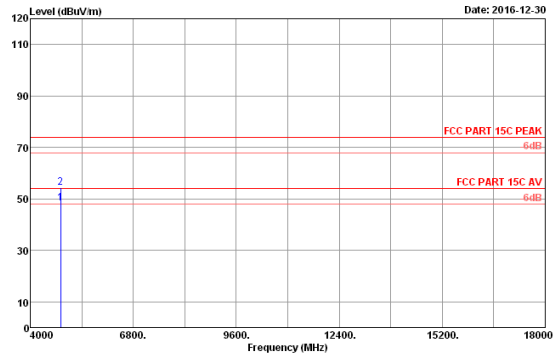

Site no. : 3m Chamber Data no. : 14
 Dis. / Ant. : 3m 2016 MCTD1209 3007 Ant. pol. : HORIZONTAL
 Limit : FCC PART 15C PEAK Pre : 101.2kPa
 Env. / Ins. : 23.1°C/54.9% Engineer : Lynn
 EUT : CaptionCall Wireless Router 2
 Power rating : DC 9V From Adapter Input AC 120W/60Hz
 Test Mode : IEEE802.11b 2412MHz Tx Mode
 N/N:CR2

No.	Freq. (MHz)	Ant. Factor (dB/m)	Cable Loss (dB)	Reading (dBUV)	AMP factor (dB)	Emission Level (dBUV/m)	Limits (dBUV/m)	Margin (dB)	Remark
1	4824.00	32.75	11.77	39.39	35.68	48.23	54.00	5.77	Average
2	4824.00	32.75	11.77	45.47	35.68	54.31	74.00	19.69	Peak

Remarks: 1. Emission Level= Antenna Factor + Cable Loss + Reading - Amp Factor
 2. The emission levels that are 20dB below the official limit are not reported.

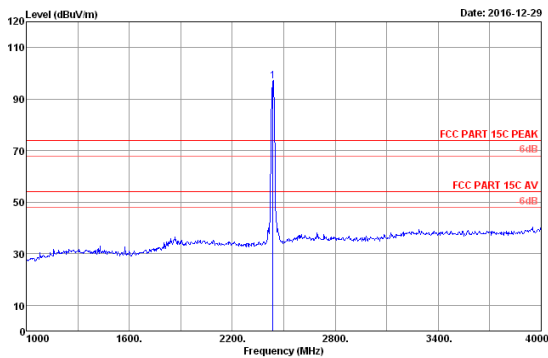

Site no. : 3m Chamber Data no. : 15
 Dis. / Ant. : 3m 2016 MCTD1209 3007 Ant. pol. : VERTICAL
 Limit : FCC PART 15C PEAK Pre : 101.2kPa
 Env. / Ins. : 23.1°C/54.9% Engineer : Lynn
 EUT : CaptionCall Wireless Router 2
 Power rating : DC 9V From Adapter Input AC 120W/60Hz
 Test Mode : IEEE802.11b 2437MHz Tx Mode
 N/N:CR2

No.	Freq. (MHz)	Ant. Factor (dB/m)	Cable Loss (dB)	Reading (dBUV)	AMP factor (dB)	Emission Level (dBUV/m)	Limits (dBUV/m)	Margin (dB)	Remark
1	2437.00	28.20	8.38	96.73	36.38	96.93	74.00	-22.93	Peak

Remarks: 1. Emission Level= Antenna Factor + Cable Loss + Reading - Amp Factor
 2. The emission levels that are 20dB below the official limit are not reported.

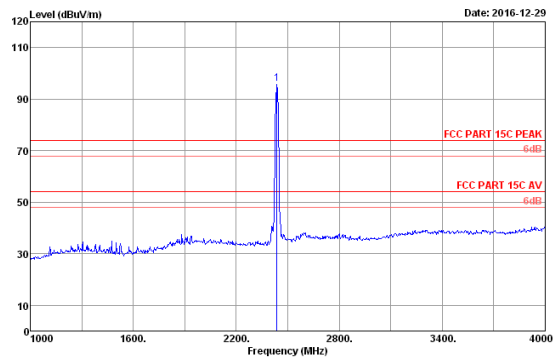

Site no. : 3m Chamber Data no. : 16
 Dis. / Ant. : 3m 2016 MCTD1209 3007 Ant. pol. : HORIZONTAL
 Limit : FCC PART 15C PEAK Pre : 101.2kPa
 Env. / Ins. : 23.1°C/54.9% Engineer : Lynn
 EUT : CaptionCall Wireless Router 2
 Power rating : DC 9V From Adapter Input AC 120W/60Hz
 Test Mode : IEEE802.11b 2437MHz Tx Mode
 N/N:CR2

No.	Freq. (MHz)	Ant. Factor (dB/m)	Cable Loss (dB)	Reading (dBUV)	AMP factor (dB)	Emission Level (dBUV/m)	Limits (dBUV/m)	Margin (dB)	Remark
1	2437.00	28.20	8.38	95.70	36.38	95.90	74.00	-21.90	Peak

Remarks: 1. Emission Level= Antenna Factor + Cable Loss + Reading - Amp Factor
 2. The emission levels that are 20dB below the official limit are not reported.