

# 47 CFR FCC Part 15 Subpart C

## Section 15.247

### Test Report

Product : **Wi-Fi 4.9mm Dual Cameras Videoscope**

Trade Name : Mitcorp

Model Number : W1149

FCC ID : 2AA5F49SW

Prepared for

**Medical Intubation Technology Corp.**

2F, No.75, Wenhwa 1st Rd., Guishan District, Taoyuan 33382, Taiwan

TEL.: +886 3 328 7177

FAX.: +886 3 328 7176

Prepared by

**Interocean EMC Technology Corp.**

**Interocean EMC Technology Tin-Fu Laboratory**

No. 5-2, Lin 1, Tin-Fu, Lin-Kou Dist., New Taipei City,

Taiwan 244, R.O.C.

TEL.: +886 2 2600 6861

FAX: +886 2 2600 6859



**Remark:**

The test report consists of **68** pages in total. It shall not be reproduced except in full, without the written approval of IETC. This document may be altered or revised by IETC only, and shall be noted in the revision section of the document.

The test result in this report is only subjected to the test sample.

# Table of Contents

<b>1</b>	<b>General Information</b>	<b>5</b>
1.1	Description of Equipment Under Test	5
1.2	Details of Tested Supporting System	6
1.3	Table for Carrier Frequencies	7
1.4	Test Facility	8
1.5	Test Equipment	9
1.6	Measurement Uncertainty	9
1.7	Summary of Measurement	10
1.8	Justification	11
1.9	Test Step of EUT	11
<b>2</b>	<b>RF radiated spurious emission test</b>	<b>12</b>
2.1	Limit	12
2.2	Configuration of Measurement	12
2.3	Test Procedure	13
2.4	Test Result	13
<b>3</b>	<b>RF Conducted spurious emission</b>	<b>20</b>
3.1	Limit	20
3.2	Configuration of Measurement	20
3.3	Test Procedure	20
3.4	Test Result	20
<b>4</b>	<b>Maximum peak output power test</b>	<b>27</b>
4.1	Limit	27
4.2	Configuration of Measurement	27
4.3	Test Procedure	27
4.4	Test Result	27
<b>5</b>	<b>6dB Bandwidth</b>	<b>29</b>
5.1	Limit	29
5.2	Configuration of Measurement	29
5.3	Test Procedure	29
5.4	Test Result	29
<b>6</b>	<b>Power spectral density</b>	<b>37</b>
6.1	Limit	37
6.2	Configuration of Measurement	37
6.3	Test Procedure	37
6.4	Test Result	37

<b>7</b>	<b>Emission on the Band Edge test</b>	<b>45</b>
7.1	Limit	45
7.2	Configuration of Measurement	45
7.3	Test Procedure	45
7.4	Test Result	45
<b>8</b>	<b>Photographs of Test</b>	<b>63</b>
8.1	Radiated Emission Measurement (Below 1 GHz)	63
8.2	Radiated Emission Measurement (Above 1 GHz)	63
<b>9</b>	<b>Photographs of EUT</b>	<b>64</b>

# Statement of Compliance

**Applicant:** Medical Intubation Technology Corp.  
**Manufacturer:** Medical Intubation Technology Corp.  
**Product:** Wi-Fi 4.9mm Dual Cameras Videoscope  
**Model No.:** W1149  
**Tested Power Supply:** DC 5 V  
**Date of Final Test:** Sep. 12, 2018  
**Revision of Report:** Rev. 02

**Configuration of Measurements and Standards Used :**

FCC Rules and Regulations Part 15 Subpart C Section 15.247

I HEREBY CERTIFY THAT: The data shown in this report were made in accordance with the procedures given in ANSI C63.10, and the energy emitted by the device was founded to be within the limits applicable. I assume full responsibility for accuracy and completeness of these data.

- Note:** 1. The result of the testing report relate only to the item tested.  
2. The testing report shall not be reproduced expect in full, without the written approval of IETC

Report Issued: 2018/10/11

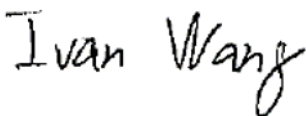
Project Engineer:   
Ivan Wang

Approved:   
Jerry Liu

## 1 General Information

### 1.1 Description of Equipment Under Test

<b>Product</b>	: Wi-Fi 4.9mm Dual Cameras Videoscope
<b>Model Number</b>	: W1149
<b>Applicant</b>	: <b>Medical Intubation Technology Corp.</b> 2F, No.75, Wenhwa 1st Rd., Guishan District, Taoyuan 33382, Taiwan
<b>Manufacturer</b>	: <b>Medical Intubation Technology Corp.</b> 2F, No.75, Wenhwa 1st Rd., Guishan District, Taoyuan 33382, Taiwan
<b>Operating Frequency</b>	: Operating frequency at 2400MHz~2483.5MHz and the each channel listed as below (802.11b/g/n (20MHz))
<b>Channel Number</b>	: The details please refer to section 1.3
<b>Type of Modulation &amp; Transfer Rate</b>	: CCK, DQPSK, DBPSK, For DSSS; 64QAM, 16QAM, QPSK, BPSK For OFDM 802.11b --- 11.0/5.5/2.0/1.0 Mbps 802.11g --- 54.0/48.0/36.0/24.0/18.0/12.0/9.0/6.0 Mbps 802.11n --- 20MHz --- 7.2Mbps
<b>Antenna Description &amp; Antenna Connector</b>	: This device uses PCB Antenna. Antenna gain: 3.7 dBi The antenna is integral to the device, thereby meeting the requirement of FCC 15.203.
<b>Measurement Software</b>	: e3; Ver: 8.120803a7-2
<b>Date of Test</b>	: Aug. 17 ~ Sep. 12, 2018
<b>Additional Description</b>	: 1. The test model is "W1149" and included in this report. 2. For more detail specification about EUT, please refer to the user's manual.

## **1.2 Details of Tested Supporting System**

N/A

### 1.3 Table for Carrier Frequencies

Operating frequency at 2400MHz~2483.5MHz and the each channel listed as below (802.11b/g/n (20MHz)):

Channel	Frequency (MHz)	Channel	Frequency (MHz)
1	2412	7	2442
2	2417	8	2447
3	2422	9	2452
4	2427	10	2457
5	2432	11	2462
6	2437		

## 1.4 Test Facility

- Site Description** : Chamber 3 RF Test Room
- Name of Firm** : Interocean EMC Technology Corp.
- Company web** : <http://www.ietc.com.tw>
- Location** : No. 5-2, Lin 1, Tin-Fu, Lin-Kou Dist., New Taipei City, Taiwan 244, R.O.C.
- Site Filing** :
- Federal Communication Commissions – USA  
Designation No.: TW1020 (Test Firm Registration #: 651092)  
Designation No.: TW1113 (Test Firm Registration #: 959554)
  - Industry Canada (IC)  
OUR FILE: 46405-4437  
Registration No. (OATS 1): Site# 4437A-1  
Registration No. (OATS 3): Site# 4437A-3  
Registration No. (Chamber 3): Site# 4437A-5  
Registration No. (OATS 5): Site# 4437A-6
  - Voluntary Control Council for Interference by Information Technology Equipment (VCCI) – Japan  
Member No.: 1349  
Registration No. (Conducted Room): C-11094  
Registration No. (Conducted Room): T-11562  
Registration No. (OATS 1): R-11040; G-10274
- Site Accreditation** :
- Bureau of Standards and Metrology and Inspection (BSMI) – Taiwan, R.O.C.  
Accreditation No.:  
SL2-IN-E-0026 for CNS 13438 / CISPR 22  
SL2-R1-E-0026 for CNS 13439 / CISPR 13  
SL2-R2-E-0026 for CNS 13439 / CISPR 13  
SL2-L1-E-0026 for CNS 14115 / CISPR 15
  - Taiwan Accreditation Foundation (TAF)  
Accreditation No.: 1113
  - Vehicle Safety Certification Center (VSCC)  
Approval No.: TW16-11
  - TÜV NORD  
Certificate No: TNTW0801R



### 1.5 Test Equipment

Instrument	Manufacturer	Model	Serial No.	Next Cal. Date
Spectrum Analyzer	R&S	FSP40	100478	2019/06/14
EMI Test Spectrum Analyzer & Receiver	R&S	ESI7	830154/002	2019/05/20
Pre-Amplifier	EMCI	EMC001150	980130	2019/06/05
Pre-Amplifier	EMCI	EMC 051845	980110	2018/09/21
Bilog Antenna	Schwarzbeck	MCTD 2786B	BLB17S04020	2019/07/08
Horn Antenna	Schwarzbeck	BBHA9120	9120D-1051	2018/11/09
RF Cable	Jye Bao	A30N30-5005	CBL51	2019/07/30
RF Cable	Jye Bao	N30N30-5006	CBL53	2019/07/30
RF Cable	HARBOUR	27478LL142	CBL65	2019/07/30
RF Cable	HARBOUR	27478LL142	CBL65	2019/07/30
RF Cable	Marvelous Microwave	MCBL-LL266.50	CBL70	2019/07/30
Measurement Software	AUDIX-e3			

Note: The above equipments are within the valid calibration period.

### 1.6 Measurement Uncertainty

Item	Value
Chamber 3:	
Radiated Emission Test (30 MHz to 1 GHz)	4.86 dB
Radiated Emission Test (above 1 GHz)	5.12 dB
The reported expanded uncertainty is based on a standard uncertainty multiplied by a coverage factor of k=2, providing a level of confidence of approximately 95%	

### 1.7 Summary of Measurement

Report Clause	Test Parameter	Reference Document 47 CFR Part15	Results
2	RF Radiated spurious emission test	§15.205, 15.209	Pass
3	RF Conducted spurious emission	§15.247(d)	Pass
4	Maximum Peak output power test	§15.247(b)	Pass
5	6dB Bandwidth	§15.247(a)(2)	Pass
6	Power spectral density	§15.247(e)	Pass
7	Emission on the Band Edge	§15.247(d)	Pass
	AC Power Line Conducted Emission test	§15.207	N/A

## **1.8 Justification**

The test of radiated measurements according to FCC Part15 Section 15.33(a) had been conducted and the field strength of the frequency band were all arrive limit requirement, thus we evaluate the EUT pass the specified test.

## **1.9 Test Step of EUT**

- 1.9.1 Setup the fixture to EUT for power supplying.
- 1.9.2 Turn on the power of all equipment.
- 1.9.3 Let the EUT continuous transmission.
- 1.9.4 Executed the test.

## 2 RF radiated spurious emission test

### 2.1 Limit

For intentional radiator, the radiated emission shall comply with §15.209(a).

For intentional radiators, according to §15.247 (a), operation under this provision is limited to frequency hopping and direct sequence spread spectrum, and the out band emission shall be comply with §15.247 (d)

Frequency (MHz)	Field strength dB( $\mu$ V/m)	Measurement distance (meters)
1.705~30.0	29.5	30
30 ~ 88	40	3
88~216	43.5	3
216~960	46	3
Above 960	54	3

### 2.2 Configuration of Measurement

Measurement Frequency under 1GHz

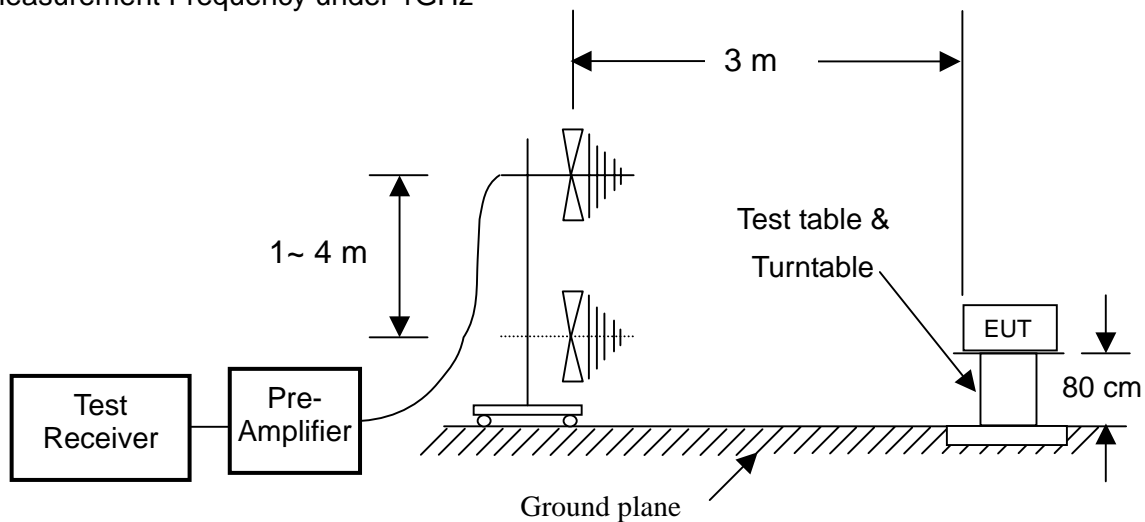

Measurement Frequency above 1GHz

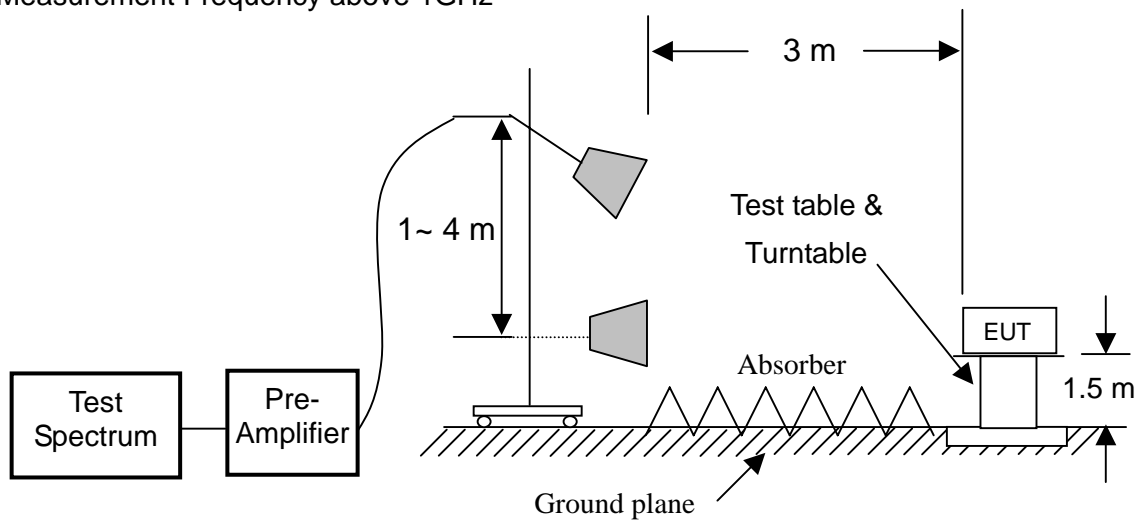

### 2.3 Test Procedure

The EUT was setup to ANSI C63.10, 2013; tested to DTS test procedure of August 24, 2018 KDB558074 D01 for compliance to FCC 47CFR 15.247 requirements.

Radiated emission measurements were performed from 30MHz to 25GHz. Spectrum Analyzer set as below: For frequency range from 30MHz to 1GHz: RBW=100kHz or greater. For frequencies above 1GHz: set RBW=VBW=1MHz for peak detector and RBW=1MHz, VBW=10Hz for average detector.

The EUT for testing is arranged on a turntable. If some peripherals apply to the EUT, the peripherals will be connected to EUT and the whole system. During the test, all cables were arranged to produce worst-case emissions. The signal is maximized through rotation. The height of antenna and polarization is changing constantly for exploring for maximum signal level. The height of antenna can be up to 4 meter and down to 1 meter.

### 2.4 Test Result

**PASS.**

The final test data is shown on as following pages.

## Radiated spurious emission

### Test Environment

Ambient temperature : 24.5°C  
 Relative humidity : 51%

### Radiated Emission below 1GHz

After verifying 802.11b/g/n modes, the worse case was found at 802.11b (CCK1M) mode, the data will present on report.

CH6 2437MHz (802.11b) data rate: CCK1M							
Frequency (MHz)	Antenna Polarization	Reading (dB $\mu$ V)	Factor (dB/m)	Result Level (dB $\mu$ V/m)	Limits (dB $\mu$ V/m)	Margin (dB)	Det. Mode
49.400	H	51.47	-13.02	38.45	40.00	-1.55	QP
136.700	H	49.79	-9.67	40.12	43.52	-3.40	QP
351.070	H	52.10	-8.14	43.96	46.02	-2.06	QP
479.110	H	49.82	-5.73	44.09	46.02	-1.93	QP
566.410	H	43.62	-4.41	39.21	46.02	-6.81	QP
967.020	H	46.19	1.91	48.10	54.00	-5.90	QP
39.700	V	47.42	-11.64	35.78	40.00	-4.22	QP
296.750	V	43.27	-9.59	33.68	46.02	-12.34	QP
351.070	V	53.71	-8.14	45.57	46.02	-0.45	QP
566.410	V	48.58	-4.41	44.17	46.02	-1.85	QP
620.730	V	44.24	-3.52	40.72	46.02	-5.30	QP
967.020	V	41.69	1.91	43.60	54.00	-10.40	QP

Remark : Result Level = Reading + Factor

Factor = Antenna Factor + Cable Loss - Preamp

Margin = Result Level - Limits

\*ANSI C63.10\_2013\_11.12.2.3: As an alternative to CISPR quasi-peak measurement, compliance can be determined for the applicable emission requirements using a peak detector.

\*The frequency range from 9 kHz to 30 MHz was pre-scanned and the results was 20 dB lower than the limit line which according to FCC 15.31(o) needs not be recorded.

CLIENT: Medical Intubation Technology Corp.  
 EUT: Wi-Fi 4.9mm Dual Cameras Videoscope  
 MODEL: W1149  
 RATING: DC 5 V  
 COMMENT: CH6 2437MHz (802.11b) data rate: CCK1M

OPERATOR : Ivan  
 TEST SITE : Chamber 3  
 TEST DISTANCE : 3m  
 POLARIZATION : HORIZONTAL  
 TEMP/HUM : 24.5°C/51%

Data:84

2018-08-28

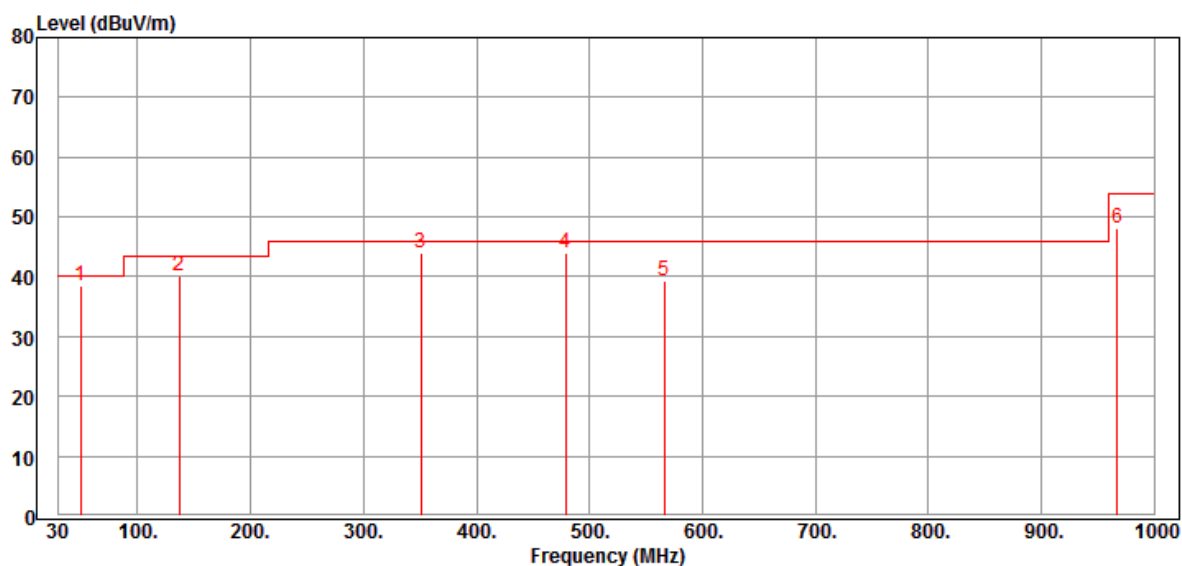

Item Mark	Freq. MHz	Reading dBuV	Factor dB/m	Level dBuV/m	Limit dBuV/m	Margin dB	Remark
1	49.400	51.47	-13.02	38.45	40.00	-1.55	QP
2	136.700	49.79	-9.67	40.12	43.52	-3.40	QP
3	351.070	52.10	-8.14	43.96	46.02	-2.06	QP
4	479.110	49.82	-5.73	44.09	46.02	-1.93	QP
5	566.410	43.62	-4.41	39.21	46.02	-6.81	QP
6	967.020	46.19	1.91	48.10	54.00	-5.90	QP

CLIENT: Medical Intubation Technology Corp.  
 EUT: Wi-Fi 4.9mm Dual Cameras Videoscope  
 MODEL: W1149  
 RATING: DC 5 V  
 COMMENT: CH6 2437MHz (802.11b) data rate: CCK1M

OPERATOR : Ivan  
 TEST SITE : Chamber 3  
 TEST DISTANCE : 3m  
 POLARIZATION : VERTICAL  
 TEMP/HUM : 24.5°C/51%

Data:85

2018-08-28

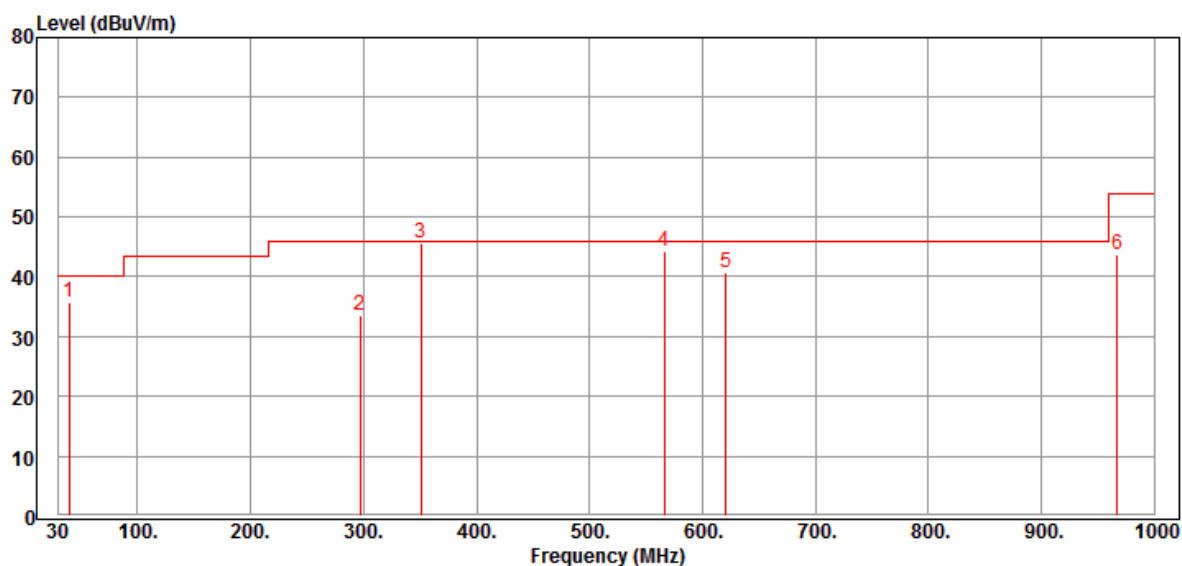

Item Mark	Freq. MHz	Reading dBuV	Factor dB/m	Level dBuV/m	Limit dBuV/m	Margin dB	Remark
1	39.700	47.42	-11.64	35.78	40.00	-4.22	QP
2	296.750	43.27	-9.59	33.68	46.02	-12.34	QP
3	351.070	53.71	-8.14	45.57	46.02	-0.45	QP
4	566.410	48.58	-4.41	44.17	46.02	-1.85	QP
5	620.730	44.24	-3.52	40.72	46.02	-5.30	QP
6	967.020	41.69	1.91	43.60	54.00	-10.40	QP



## Radiated spurious emission

### Test Environment

Ambient temperature : 24.5°C

Relative humidity : 51%

### Radiated Emission above 1GHz

CH1 2412MHz (802.11b) data rate: CCK1M							
Frequency (MHz)	Antenna Polarization	Reading (dB $\mu$ V)	Factor (dB/m)	Result Level (dB $\mu$ V/m)	Limits (dB $\mu$ V/m)	Margin (dB)	Det. Mode
4827.0	H	46.32	-5.00	41.32	74	-32.68	PK
7235.0	H	50.35	2.24	52.59	74	-21.41	PK
4827.0	V	48.24	-5.00	43.34	74	-30.66	PK
7235.0	V	58.93	2.24	61.17	74	-12.83	PK
7235.0	V	49.61	2.24	51.85	54	-2.15	AV

CH6 2437MHz (802.11b) data rate: CCK1M							
Frequency (MHz)	Antenna Polarization	Reading (dB $\mu$ V)	Factor (dB/m)	Result Level (dB $\mu$ V/m)	Limits (dB $\mu$ V/m)	Margin (dB)	Det. Mode
4876.0	H	47.88	-4.84	43.04	74	-30.96	PK
7312.0	H	47.14	2.50	49.64	74	-24.36	PK
4876.0	V	47.95	-4.84	43.11	74	-30.89	PK
7312.0	V	46.81	2.50	49.31	74	-24.69	PK

CH11 2462MHz (802.11b) data rate: CCK1M							
Frequency (MHz)	Antenna Polarization	Reading (dB $\mu$ V)	Factor (dB/m)	Result Level (dB $\mu$ V/m)	Limits (dB $\mu$ V/m)	Margin (dB)	Det. Mode
4925.0	H	53.88	-4.70	49.18	74	-24.82	PK
7389.0	H	55.41	2.75	58.16	74	-15.84	PK
7389.0	H	48.21	2.75	50.96	54	-3.04	AV
4925.0	V	51.17	-4.70	46.47	74	-27.53	PK
7389.0	V	58.52	2.75	61.27	74	-12.73	PK
7389.0	V	46.53	2.75	49.28	54	-4.72	AV

Remark : Result Level = Reading + Factor

Factor = Antenna Factor + Cable Loss - Preamp

Margin = Result Level - Limits

\* Mark indicated background noise level.

The spurious emissions above 9GHz were not included, because the emissions are too low.

CH1 2412MHz (802.11g) data rate: OFDM6M							
Frequency (MHz)	Antenna Polarization	Reading (dB $\mu$ V)	Factor (dB/m)	Result Level (dB $\mu$ V/m)	Limits (dB $\mu$ V/m)	Margin (dB)	Det. Mode
4827.0	H	52.01	-5.00	47.01	74	-26.99	PK
7235.0	H	57.85	2.24	60.09	74	-13.91	PK
7235.0	H	50.24	2.24	52.48	54	-1.52	AV
4827.0	V	48.99	-5.00	43.99	74	-30.01	PK
7235.0	V	58.36	2.24	60.60	74	-13.40	PK
7235.0	V	49.05	2.24	51.29	54	-2.71	AV

CH6 2437MHz (802.11g) data rate: OFDM6M							
Frequency (MHz)	Antenna Polarization	Reading (dB $\mu$ V)	Factor (dB/m)	Result Level (dB $\mu$ V/m)	Limits (dB $\mu$ V/m)	Margin (dB)	Det. Mode
4876.0	H	46.68	-4.84	41.84	74	-32.16	PK
7312.0	H	50.24	2.50	52.74	74	-21.26	PK
7312.0	H	47.18	2.50	49.68	54	-4.32	AV
4876.0	V	48.57	-4.84	43.73	74	-30.27	PK
7312.0	V	54.20	2.50	56.70	74	-17.30	PK
7312.0	V	47.37	2.50	49.87	54	-4.13	AV

CH11 2462MHz (802.11g) data rate: OFDM6M							
Frequency (MHz)	Antenna Polarization	Reading (dB $\mu$ V)	Factor (dB/m)	Result Level (dB $\mu$ V/m)	Limits (dB $\mu$ V/m)	Margin (dB)	Det. Mode
4925.0	H	51.25	-4.70	46.55	74	-27.45	PK
7389.0	H	57.81	2.75	60.56	74	-13.44	PK
7389.0	H	48.63	2.75	51.38	54	-2.62	AV
4925.0	V	48.04	-4.70	43.34	74	-30.66	PK
7389.0	V	54.54	2.75	57.29	74	-16.71	PK
7389.0	V	45.51	2.75	48.26	54	-5.74	AV

Remark : Result Level = Reading + Factor

Factor = Antenna Factor + Cable Loss - Preamp

Margin = Result Level - Limits

\* Mark indicated background noise level.

The spurious emissions above 9GHz were not included, because the emissions are too low.

CH1 2412MHz (802.11n; 20MHz ) data rate: MCS0							
Frequency (MHz)	Antenna Polarization	Reading (dB $\mu$ V)	Factor (dB/m)	Result Level (dB $\mu$ V/m)	Limits (dB $\mu$ V/m)	Margin (dB)	Det. Mode
4827.0	H	49.44	-5.00	44.44	74	-29.56	PK
7235.0	H	52.46	2.24	54.70	74	-19.30	PK
7235.0	H	48.36	2.24	50.60	74	-23.40	AV
4827.0	V	44.84	-5.00	39.84	74	-34.16	PK
7235.0	V	50.02	2.24	52.26	74	-21.74	PK

CH6 2437MHz (802.11n; 20MHz ) data rate: MCS0							
Frequency (MHz)	Antenna Polarization	Reading (dB $\mu$ V)	Factor (dB/m)	Result Level (dB $\mu$ V/m)	Limits (dB $\mu$ V/m)	Margin (dB)	Det. Mode
4876.0	H	50.23	-4.84	45.39	74	-28.61	PK
7312.0	H	58.88	2.50	61.38	74	-12.62	PK
7312.0	H	48.12	2.50	50.62	54	-3.38	AV
4876.0	V	47.85	-4.84	43.01	74	-30.99	PK
7312.0	V	50.64	2.50	53.14	74	-20.86	PK
7312.0	V	48.85	2.50	50.95	54	-3.05	AV

CH11 2462MHz(802.11n; 20MHz ) data rate: MCS0							
Frequency (MHz)	Antenna Polarization	Reading (dB $\mu$ V)	Factor (dB/m)	Result Level (dB $\mu$ V/m)	Limits (dB $\mu$ V/m)	Margin (dB)	Det. Mode
4925.00	H	50.88	-4.70	46.18	74	-27.82	PK
7389.00	H	52.28	2.75	55.03	74	-18.97	PK
7389.00	H	47.96	2.75	50.71	54	-3.29	AV
4925.00	V	46.64	-4.70	41.94	74	-32.06	PK
7389.00	V	56.85	2.75	59.60	74	-14.40	PK
7389.00	V	46.57	2.75	49.32	54	-4.68	AV

Remark : Result Level = Reading + Factor

Factor = Antenna Factor + Cable Loss - Preamp

Margin = Result Level - Limits

\* Mark indicated background noise level.

The spurious emissions above 9GHz were not included, because the emissions are too low.

### 3 RF Conducted spurious emission

#### 3.1 Limit

According to 15.247(d) requirement :

In any 100 kHz bandwidth outside the frequency band in which the spread spectrum or digitally modulated intentional radiator is operating, the radio frequency power that is produced by the intentional radiator shall be at least 20 dB below that in the 100 kHz bandwidth within the band that contains the highest level of the desired power, based on either an RF conducted or a radiated measurement, provided the transmitter demonstrates compliance with the peak conducted power limits.

#### 3.2 Configuration of Measurement

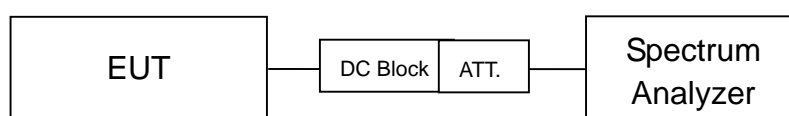

#### 3.3 Test Procedure

The EUT was setup to ANSI C63.10, 2013; tested to DTS test procedure of August 24, 2018 KDB558074 D01 for compliance to FCC 47CFR 15.247 requirements.

The measurements were performed from 30MHz to 25GHz RF antenna conducted per FCC 15.247 (c) was measured from the EUT antenna port using a 50ohm spectrum analyzer with the resolution bandwidth set at 100 kHz, and the video bandwidth set  $\geq$  RBW.

Harmonics and spurious noise must be at least 20dB down from the highest emission level within the authorized band as measured with a 100 kHz RBW. The table below is the results from the highest emission for each channel within the authorized band. This table was used to determine the spurious limit for each channel.

#### 3.4 Test Result

**PASS.**

# Conducted spurious emission

## CH1 2412MHz (802.11b)

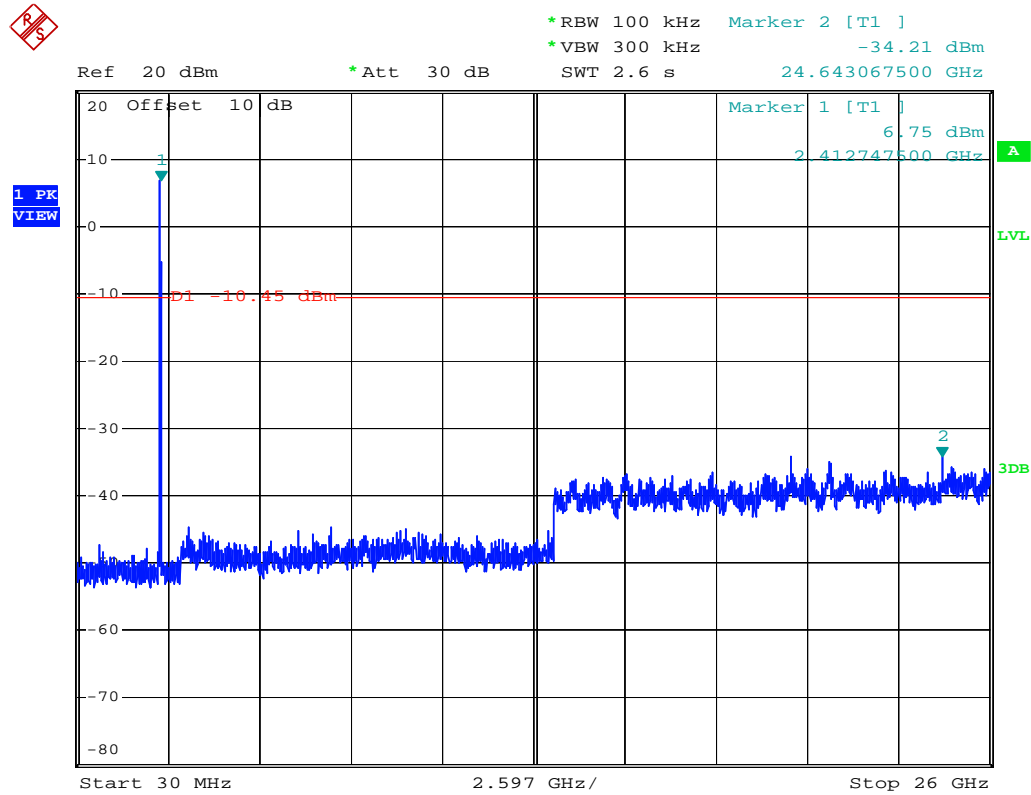

## CH6 2437MHz (802.11b)

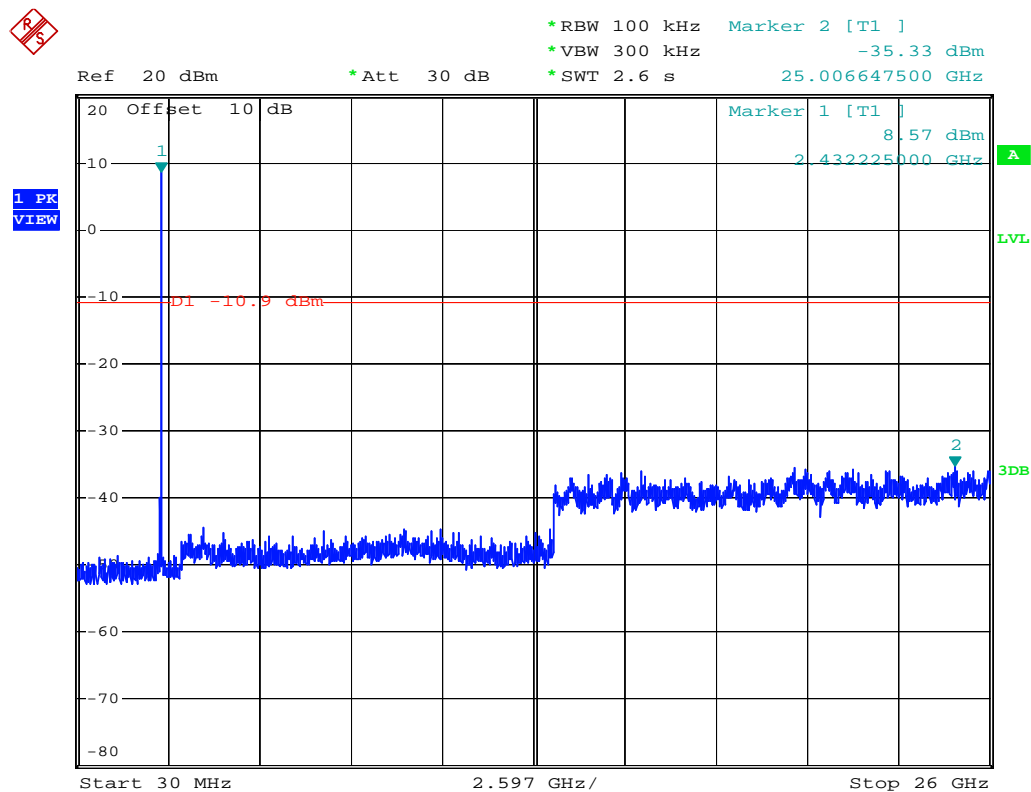

### CH11 2462MHz (802.11b)

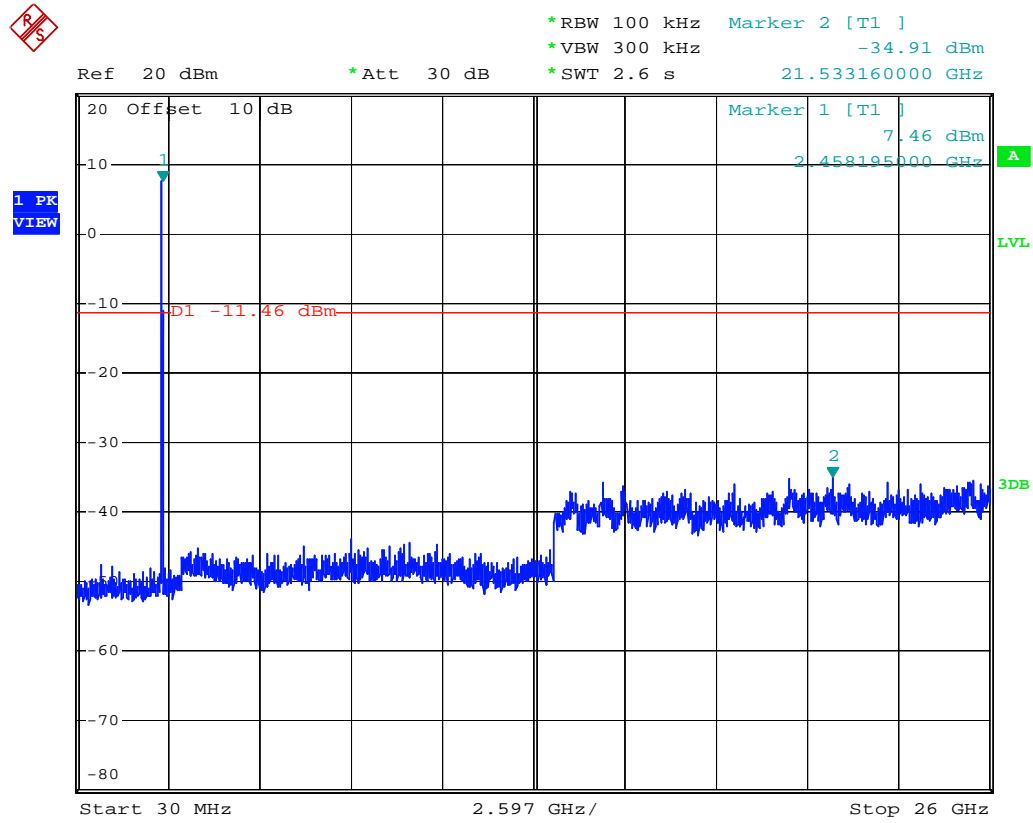

### CH1 2412MHz (802.11g)

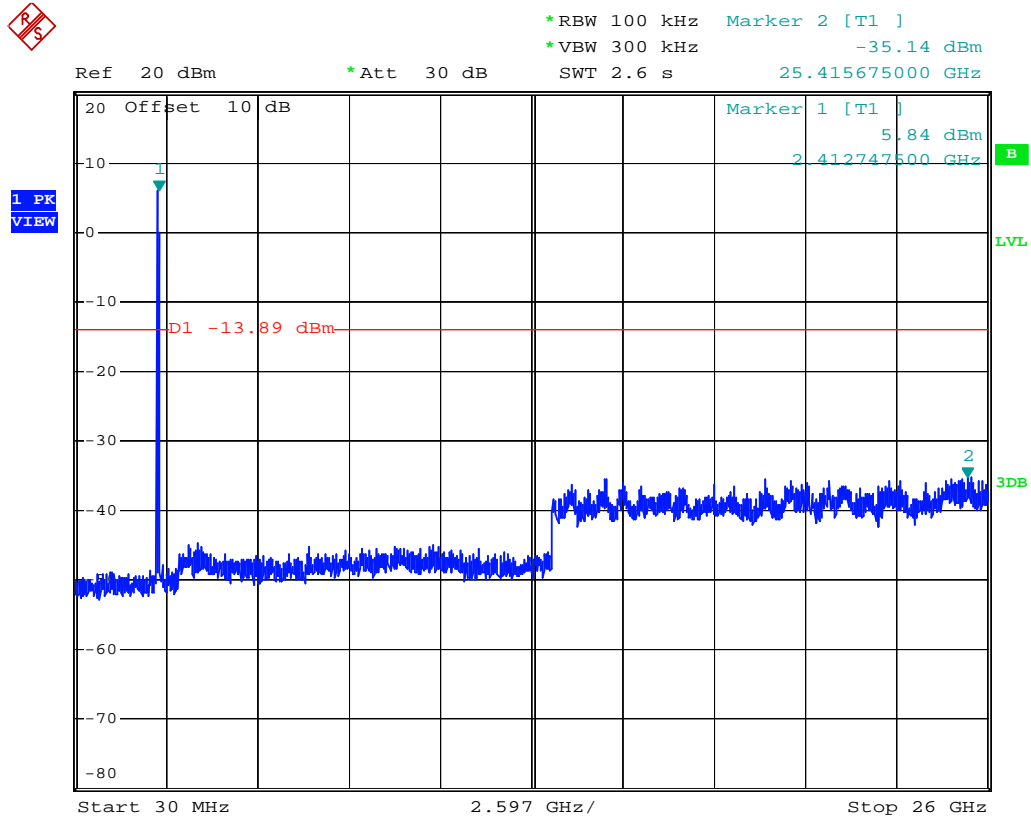

### CH6 2437MHz (802.11g)

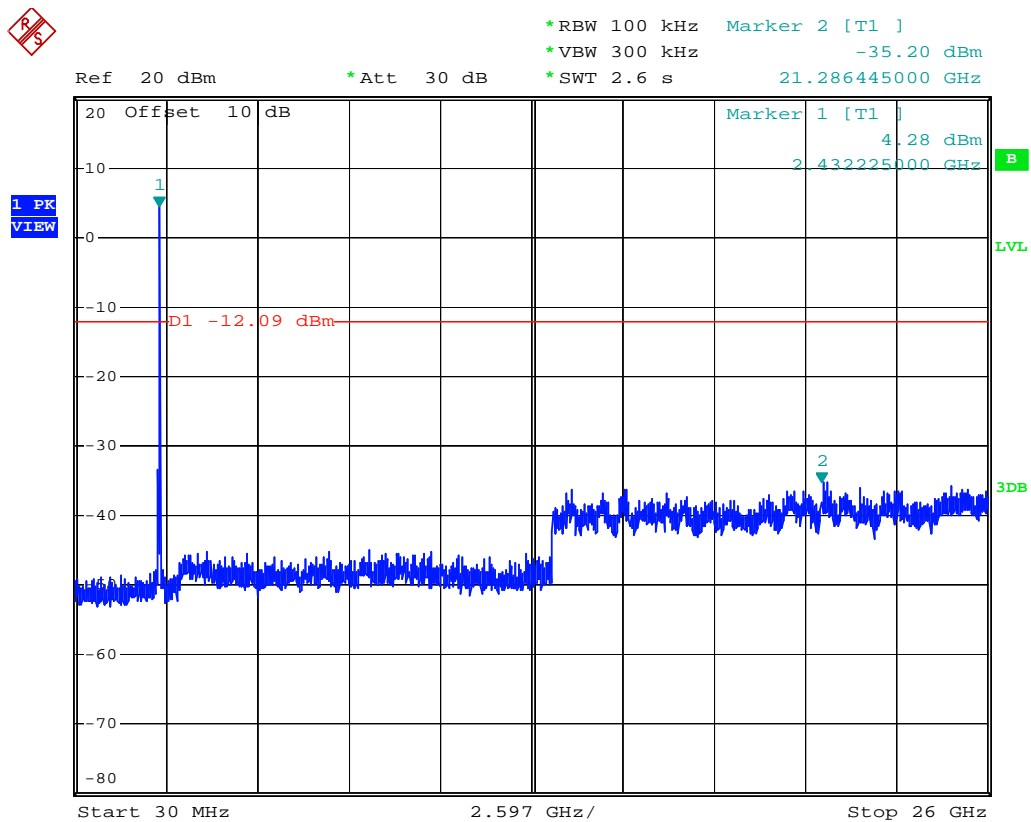

### CH11 2462MHz (802.11g)

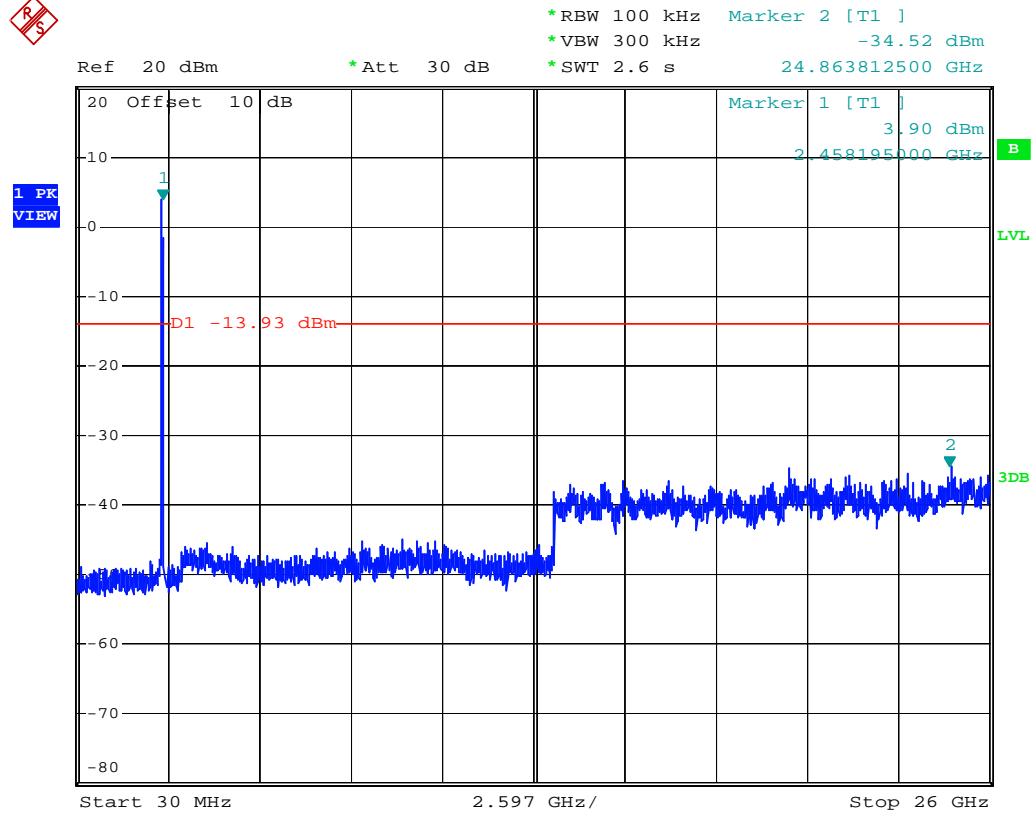



### CH1 2412MHz (802.11n)

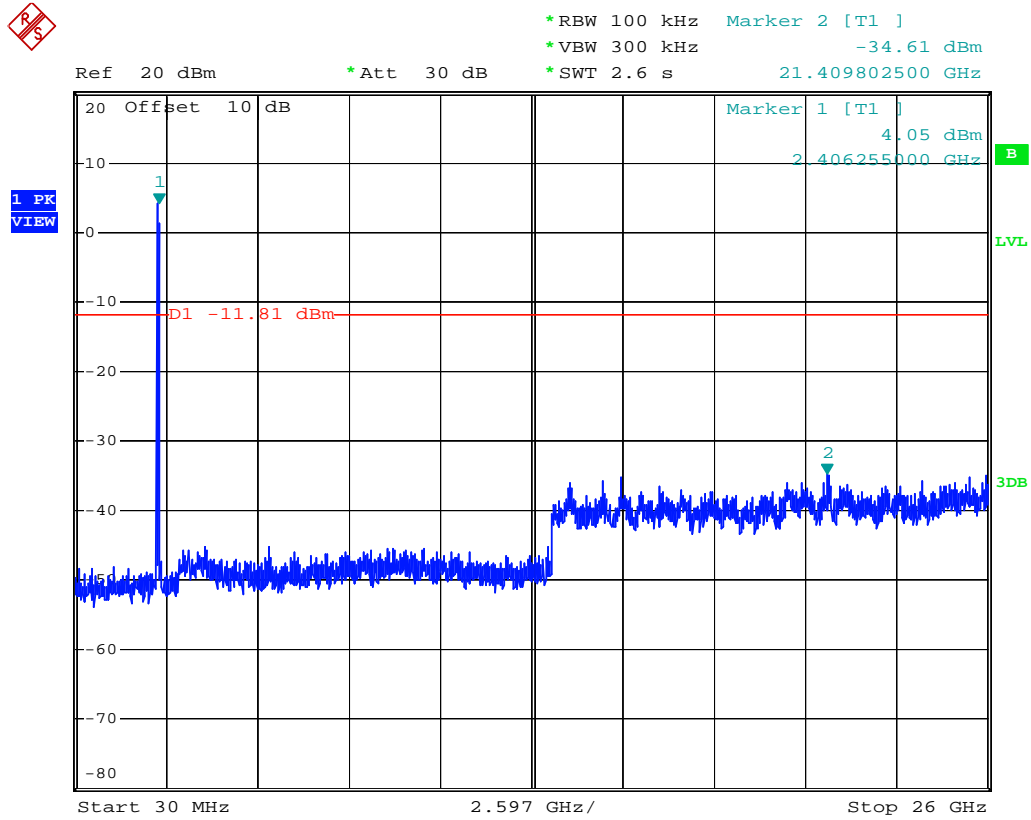

### CH6 2437MHz (802.11n)

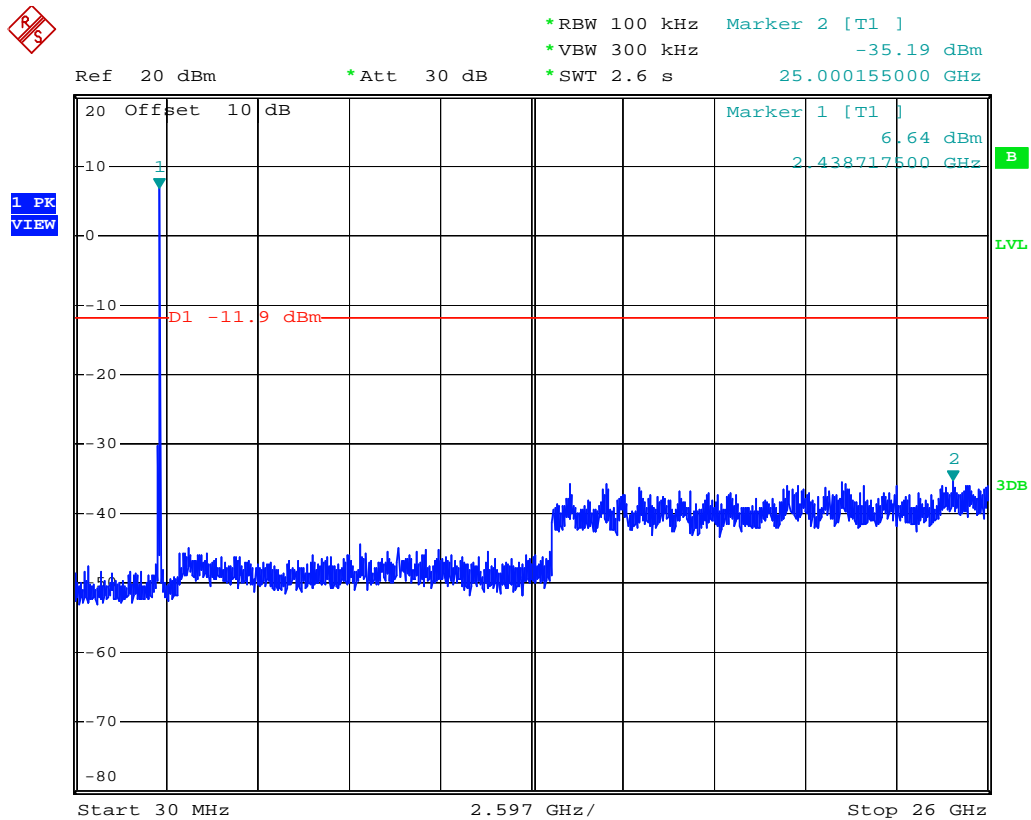

### CH11 2462MHz (802.11n)

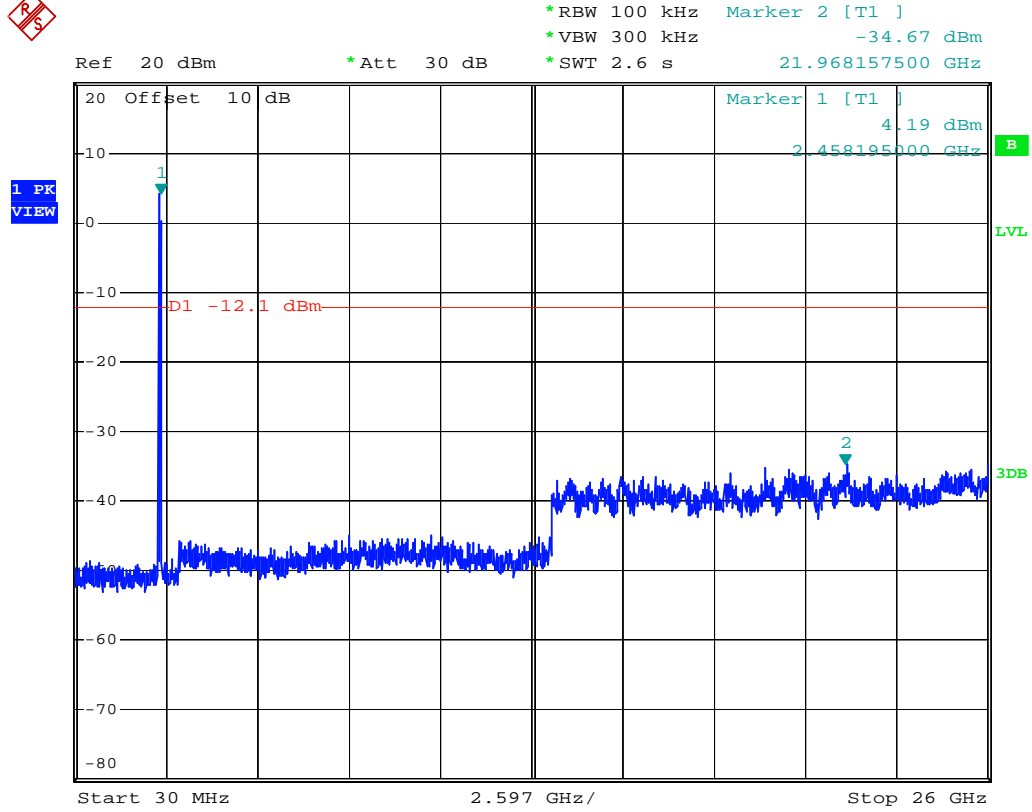

## 4 Maximum peak output power test

### 4.1 Limit

According to FCC Part15.247 (b)(3) requirement :

For systems using digital modulation in the 2400–2483.5 MHz bands: The maximum conducted output power shall be less than 1Watt.

### 4.2 Configuration of Measurement

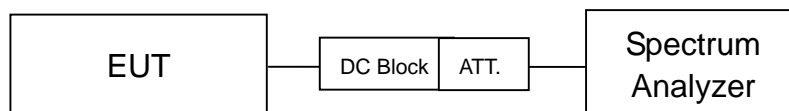

### 4.3 Test Procedure

The EUT was setup to ANSI C63.10, 2013; tested to DTS test procedure of August 24, 2018 KDB558074 D01 for compliance to FCC 47CFR 15.247 requirements.

For FCC §15.247(b) the power output was measured on the EUT using a 50 ohm SMA cable connected to Spectrum Analyzer. Peak output power was read directly from Spectrum Analyzer.

Set :

- (1)  $RBW \geq$  DTS bandwidth,  $VBW \geq 3 \times RBW$
- (2)  $Span \geq 3 \times EBW$
- (3) Detector = peak, trace mode = max hold
- (4) All trace to fully stabilize
- (5) Use peak marker function to determine the peak amplitude

### 4.4 Test Result

**PASS.**

The final test data is shown on as following pages.

Remark:

1. Output power = Reading + factor
2. Margin = Output power - Limit

## Maximum output power

### Mode : 802.11b (data rate: CCK1M)

Test CH		Output Power (dBm)	Output Power (mW)	Limit (dBm)	Magrin (dB)
CH No.	Freq. (MHz)				
1	2412	22.28	169.04	30	-7.72
6	2437	22.26	168.27	30	-7.74
11	2462	22.16	164.44	30	-7.84

### Mode : 802.11g (data rate: OFDM6M)

Test CH		Output Power (dBm)	Output Power (mW)	Limit (dBm)	Magrin (dB)
CH No.	Freq. (MHz)				
1	2412	26.23	419.76	30	-3.77
6	2437	25.94	392.64	30	-4.06
11	2462	25.59	362.24	30	-4.41

### Mode : 802.11n (20MHz; data rate: MCS0)

Test CH		Output Power (dBm)	Output Power (mW)	Limit (dBm)	Magrin (dB)
CH No.	Freq. (MHz)				
1	2412	25.79	379.31	30	-4.21
6	2437	25.76	376.70	30	-4.24
11	2462	25.41	347.54	30	-4.59

## 5 6dB Bandwidth

### 5.1 Limit

According to FCC Part15.247 (a)(2) requirement :

Systems using digital modulation techniques may operate in the 2400–2483.5 MHz, The minimum 6dB bandwidth shall be at least 500 kHz.

### 5.2 Configuration of Measurement

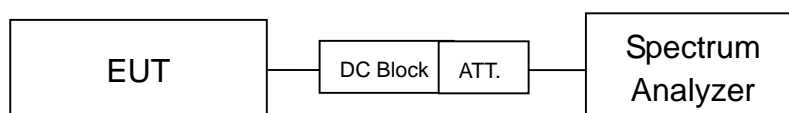

### 5.3 Test Procedure

The EUT was setup to ANSI C63.10, 2013; tested to DTS test procedure of August 24, 2018 KDB558074 D01 for compliance to FCC 47CFR 15.247 requirements.

The minimum 6dB bandwidth was measured using a 50 ohm spectrum analyzer.

- (1) RBW = 100kHz
- (2) VBW  $\geq$  3 x RBW
- (3) Detector = Peak
- (4) Trace mode = Max hold
- (5) Sweep = auto couple
- (6) All trace to fully stabilize
- (7) Measure the maximum width of the emission that is constrained by the frequencies associated with the two outermost amplitude points (upper and lower frequencies) that are attenuated by 6dB relative to the maximum level measured in the fundamental emission.

### 5.4 Test Result

**PASS.**

The final test data is shown on as following pages.

## 6dB bandwidth

### Test Mode : 802.11b (data rate: CCK1M)

Test CH		6dB Bandwidth (MHz)	Limit (kHz)	Result
CH No.	Freq. (MHz)			
1	2412	10.08	>500	Pass
6	2437	9.48	>500	Pass
11	2462	10.08	>500	Pass

### Test Mode : 802.11g (data rate: OFDM6M)

Test CH		6dB Bandwidth (MHz)	Limit (kHz)	Result
CH No.	Freq. (MHz)			
1	2412	13.20	>500	Pass
6	2437	13.56	>500	Pass
11	2462	13.38	>500	Pass

### Test Mode : 802.11n (20MHz; data rate: MCS0)

Test CH		6dB Bandwidth (MHz)	Limit (kHz)	Result
CH No.	Freq. (MHz)			
1	2412	13.15	>500	Pass
6	2437	13.80	>500	Pass
11	2462	13.30	>500	Pass

### 6dB Bandwidth

802.11b (data rate: CCK1M)  
CH No. 1 (2412 MHz)

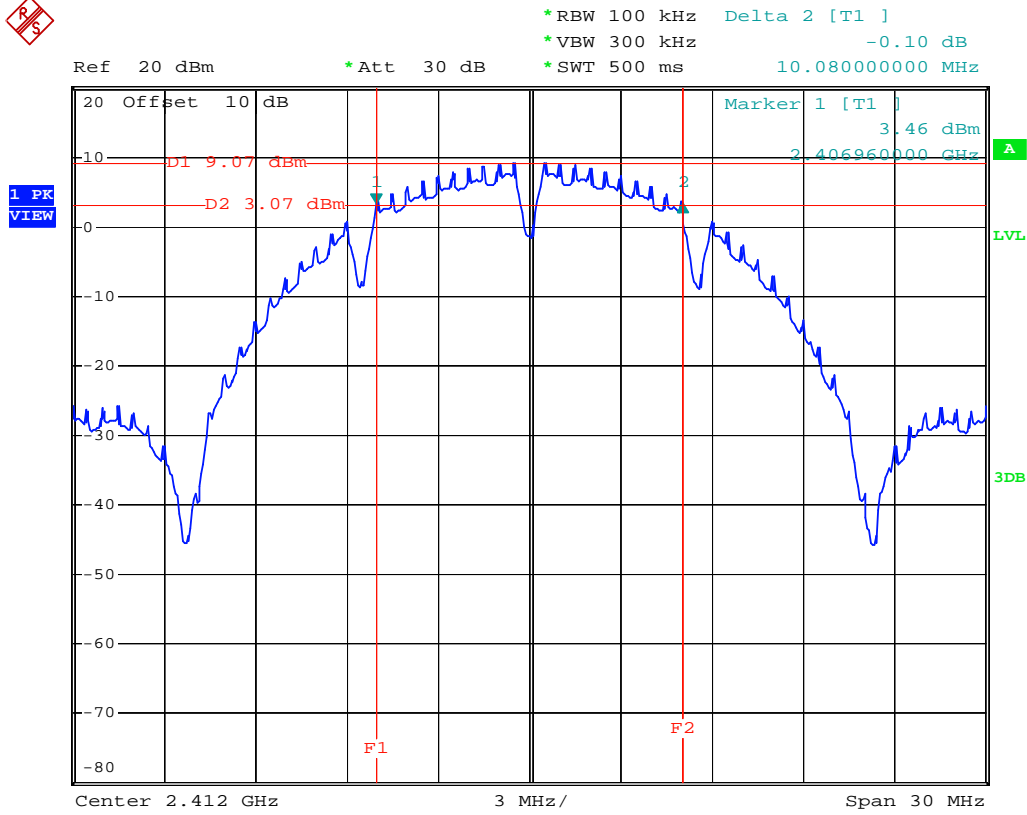

CH No. 6 (2437 MHz)

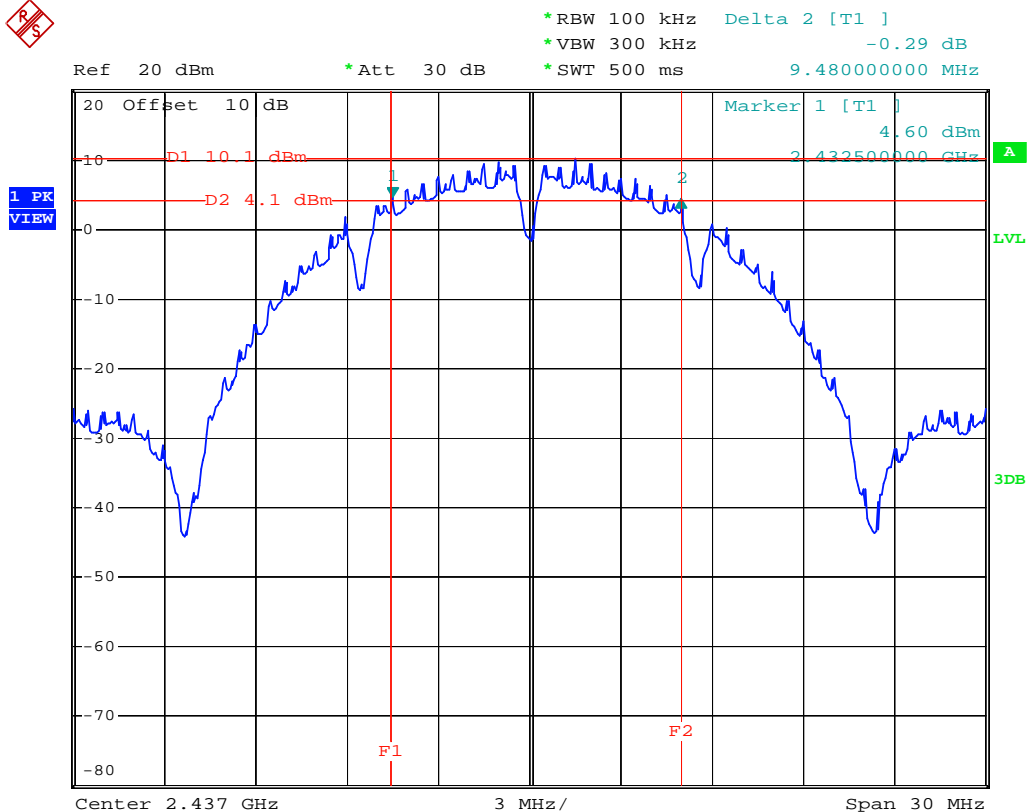

### CH No. 11 (2462 MHz)

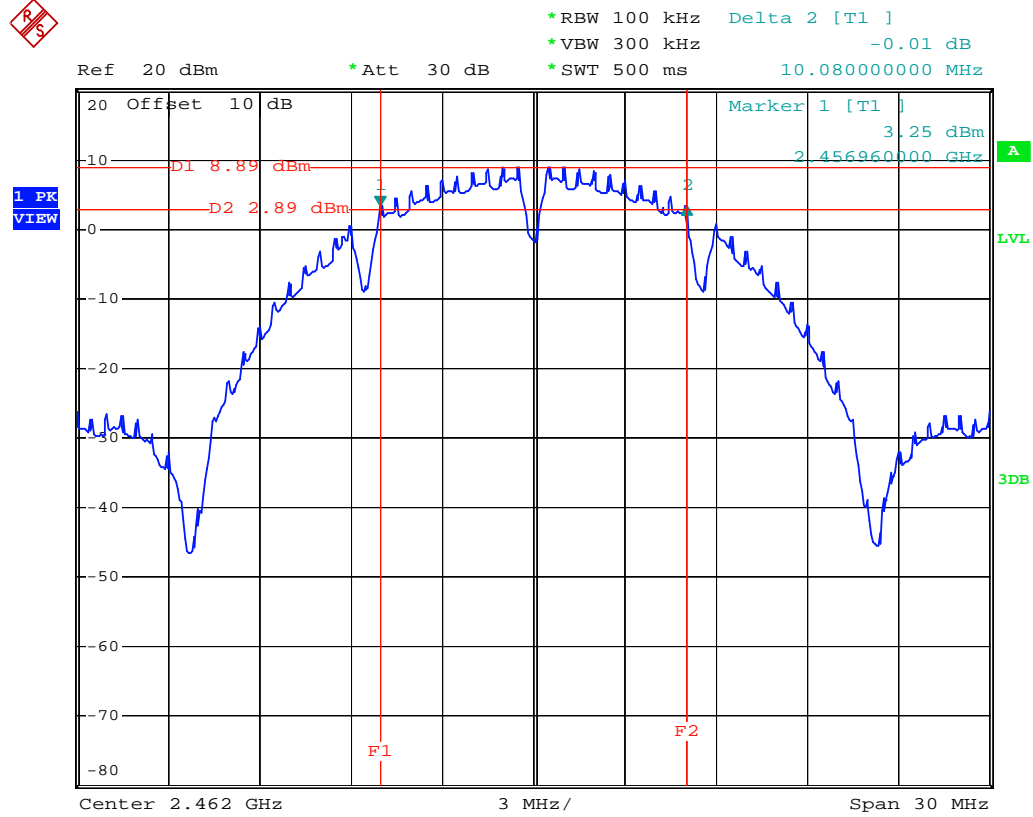



### 802.11g (data rate: OFDM6M) CH No. 1 (2412 MHz)

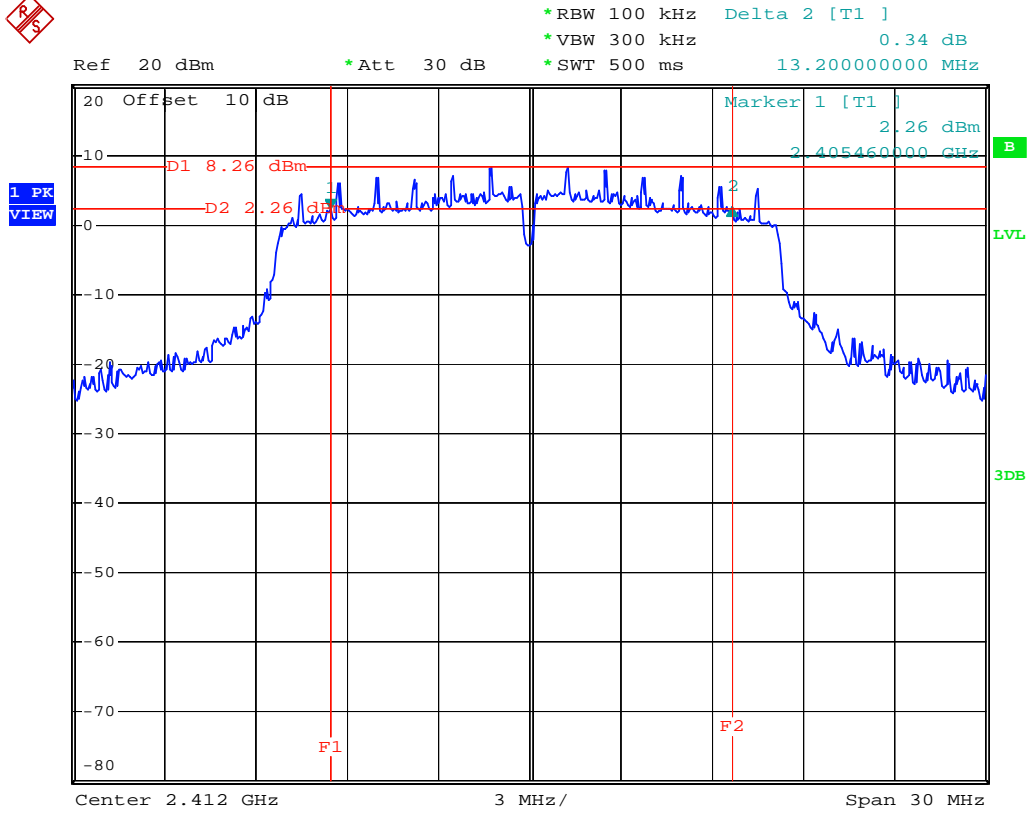

### CH No. 6 (2437 MHz)

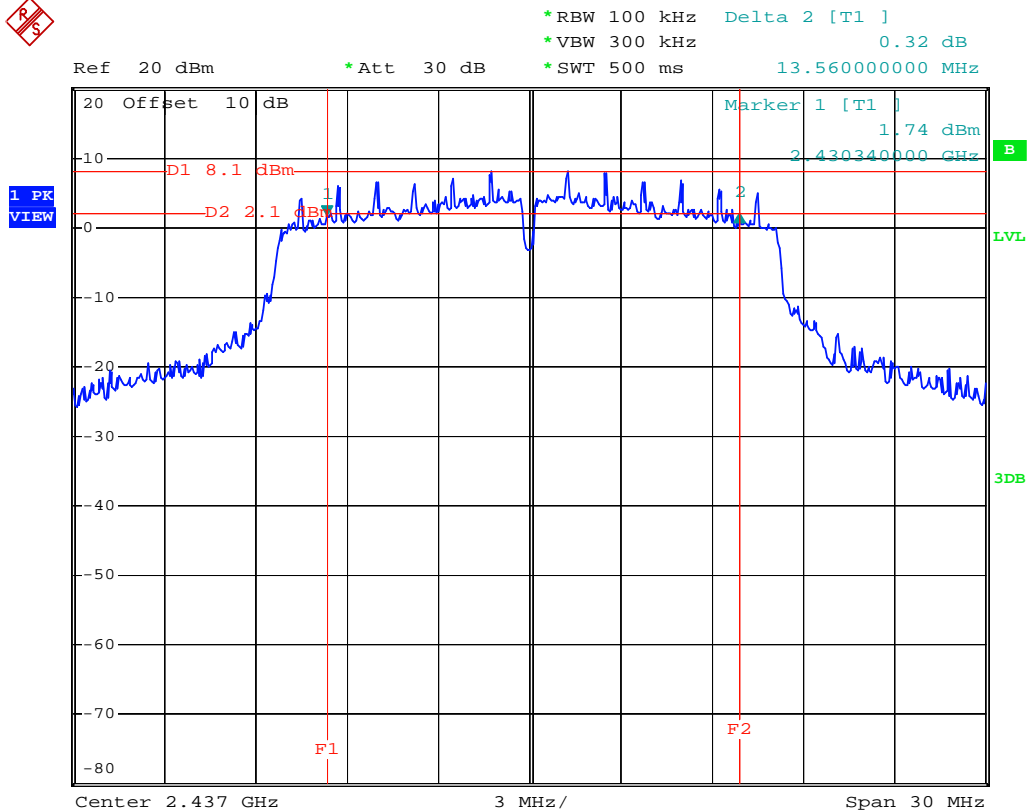

### CH No. 11 (2462 MHz)

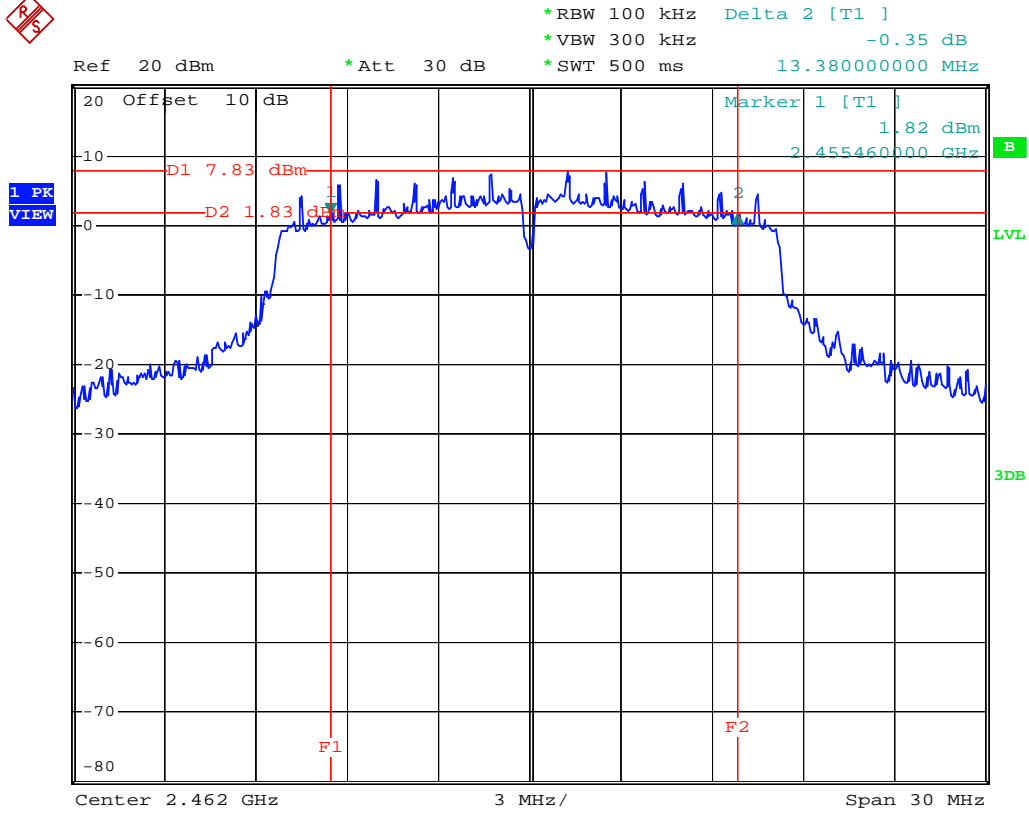

### 802.11n (20MHz; data rate: MCS0) CH No. 1 (2412 MHz)

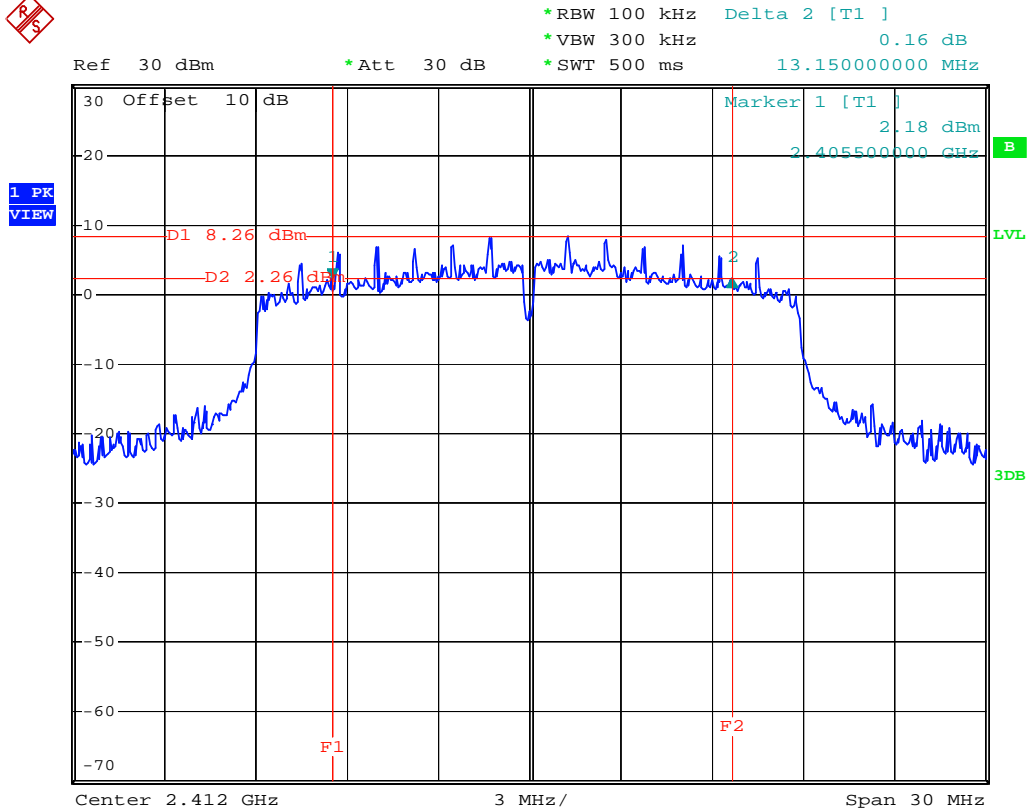

### CH No. 6 (2437 MHz)

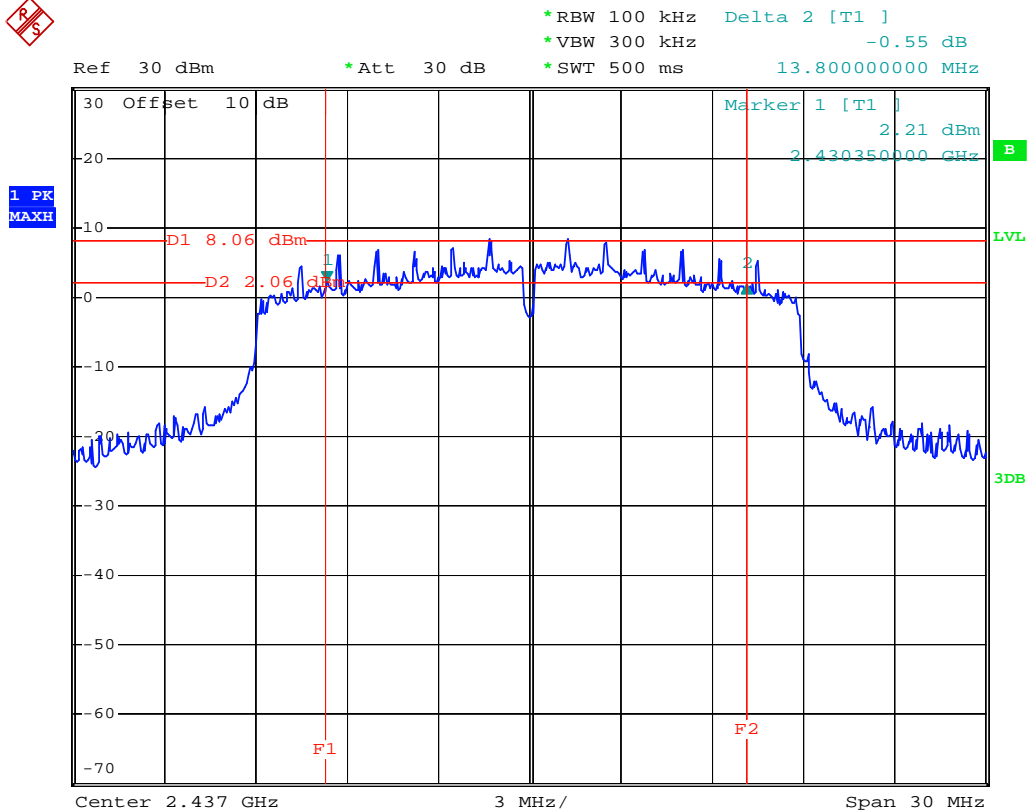

### CH No. 11 (2462 MHz)

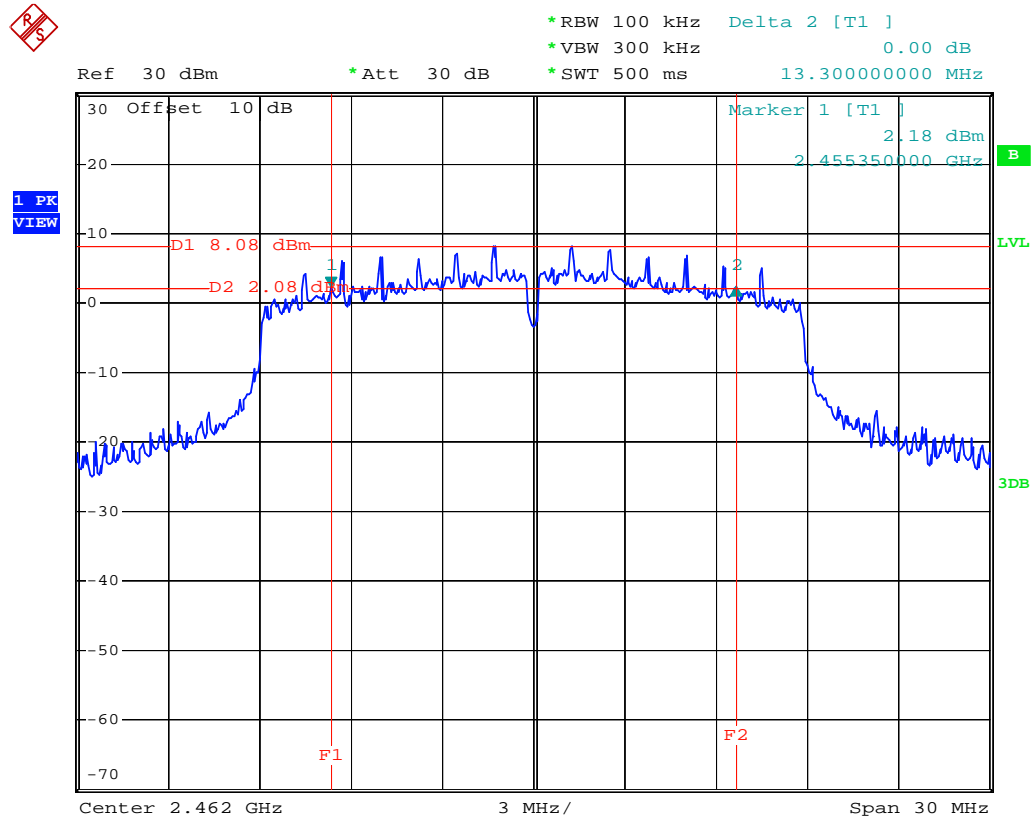

## 6 Power spectral density

### 6.1 Limit

According to FCC Part15.247 (e) requirement :

For digitally modulated systems, the power spectral density conducted from the intentional radiator to the antenna shall not be greater than 8 dBm in any 3 kHz band during any time interval of continuous transmission.

### 6.2 Configuration of Measurement

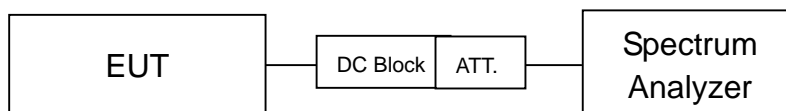

### 6.3 Test Procedure

The EUT was setup to ANSI C63.10, 2013; tested to DTS test procedure of August 24, 2018 KDB558074 D01 for compliance to FCC 47CFR 15.247 requirements.

Set::

- (1) Analyzer center frequency to DTS channel center frequency
- (2) The span to 1.5 times the DTS bandwidth
- (3) RBW:  $3\text{kHz} \leq \text{RBW} \leq 100\text{kHz}$
- (4) VBW  $\geq 3 \times \text{RBW}$
- (5) Detector = Peak
- (6) Trace mode = Max hold
- (7) Sweep = auto couple
- (8) All trace to fully stabilize
- (9) Use the peak marker function to determine the maximum amplitude level within the RBW
- (10) If measured value exceeds limit, reduce RBW (no less than 3kHz) and repeat

### 6.4 Test Result

**PASS.**

The final test data is shown on as following pages.

Remark:

1. PSD = Reading + factor
2. Margin = Output power – Limit

## Power spectral density

### 802.11b (data rate: CCK1M)

Test CH		PSD	Limit	Result
CH No.	Freq. (MHz)	(dBm/3kHz)	(dBm/3kHz)	
1	2412	5.51	8	PASS
6	2437	3.84	8	PASS
11	2462	6.28	8	PASS

### 802.11g (data rate: OFDM6M)

Test CH		PSD	Limit	Result
CH No.	Freq. (MHz)	(dBm/3kHz)	(dBm/3kHz)	
1	2412	-7.93	8	PASS
6	2437	-9.27	8	PASS
11	2462	-9.32	8	PASS

### 802.11n (20MHz; data rate: MCS0)

Test CH		PSD	Limit	Result
CH No.	Freq. (MHz)	(dBm/3kHz)	(dBm/3kHz)	
1	2412	-8.60	8	PASS
6	2437	-8.79	8	PASS
11	2462	-7.33	8	PASS

# Power spectral density

802.11b (data rate: CCK1M)  
CH No. 1 (2412 MHz)



\*RBW 3 kHz    Marker 1 [T1 ]  
\*VBW 30 kHz    5.21 dBm  
\*Att 30 dB    \*SWT 1.7 s    2.40825000 GHz

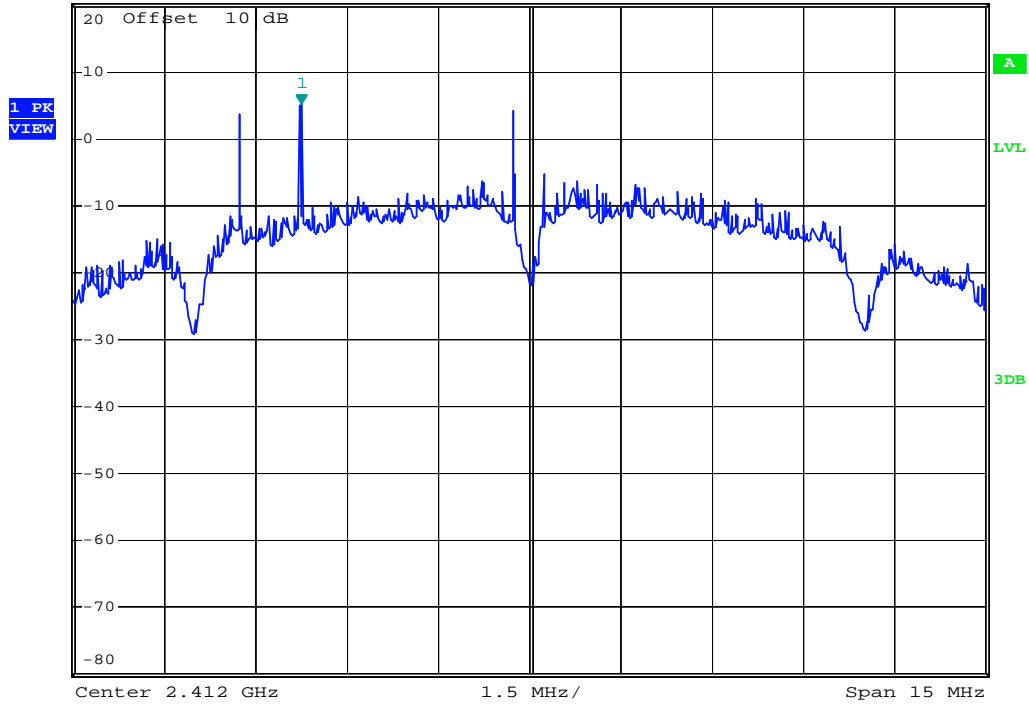

CH No. 6 (2437 MHz)



\*RBW 3 kHz    Marker 1 [T1 ]  
\*VBW 30 kHz    3.84 dBm  
\*Att 30 dB    \*SWT 1.6 s    2.437252000 GHz

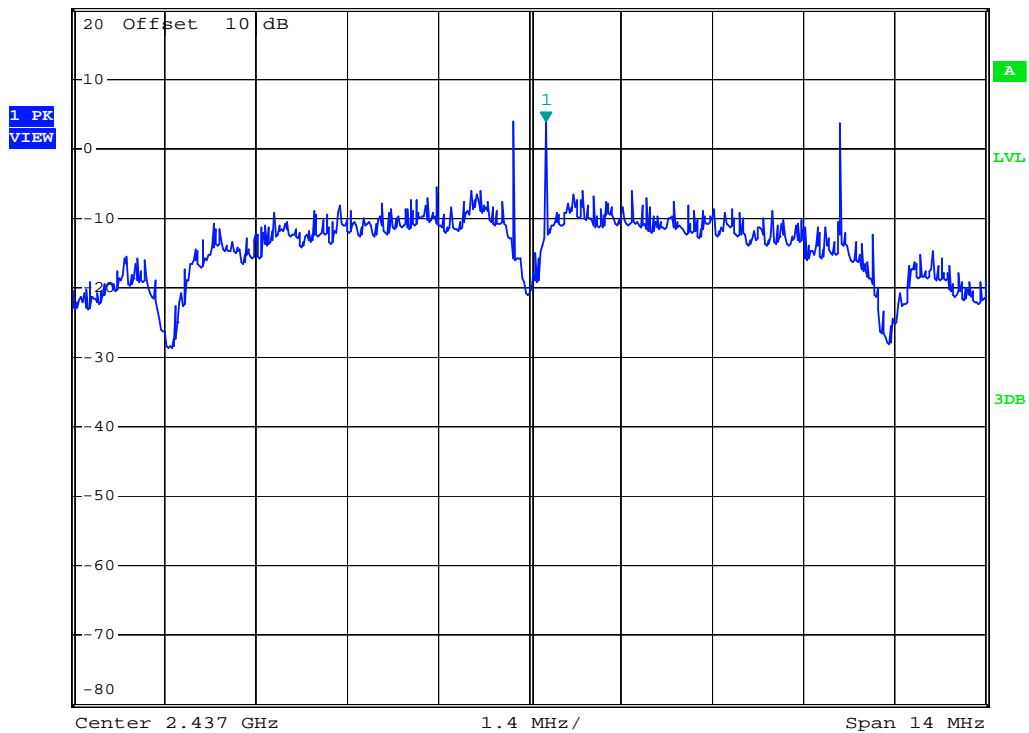

### CH No. 11 (2462 MHz)

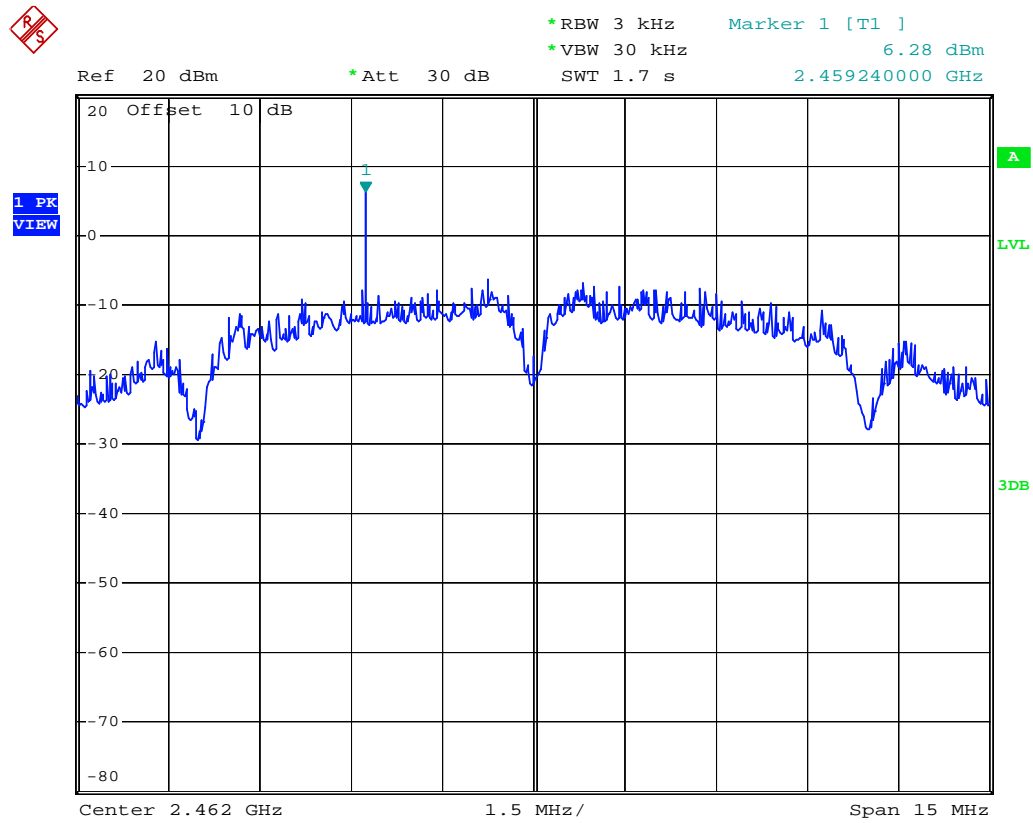



### 802.11g (data rate: OFDM6M) CH No. 1 (2412 MHz)

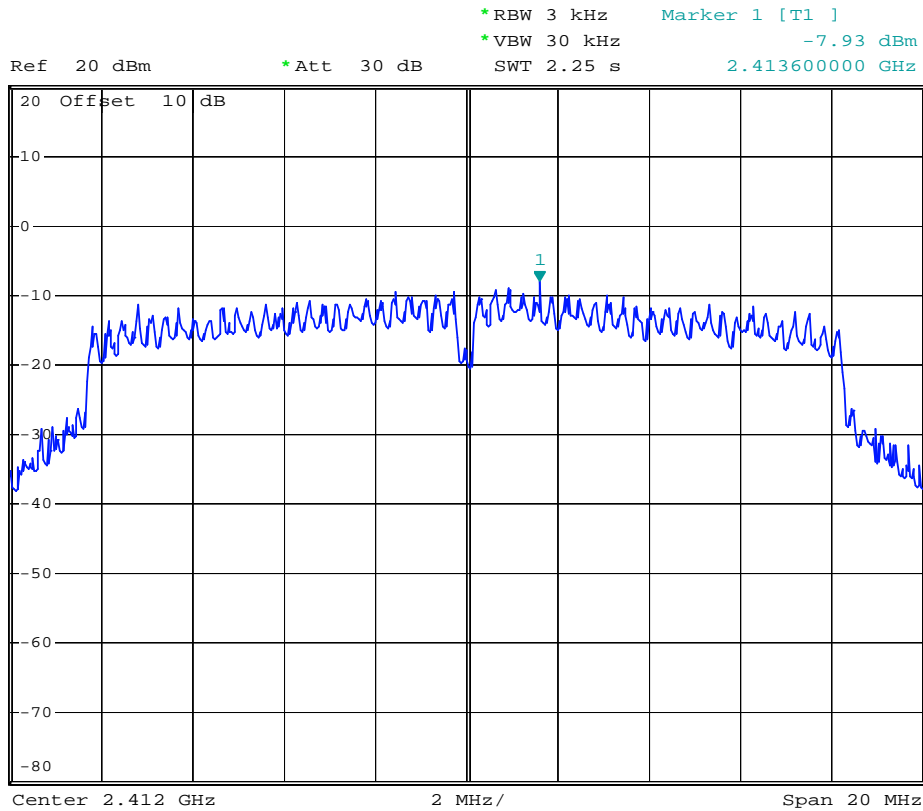

### CH No. 6 (2437 MHz)

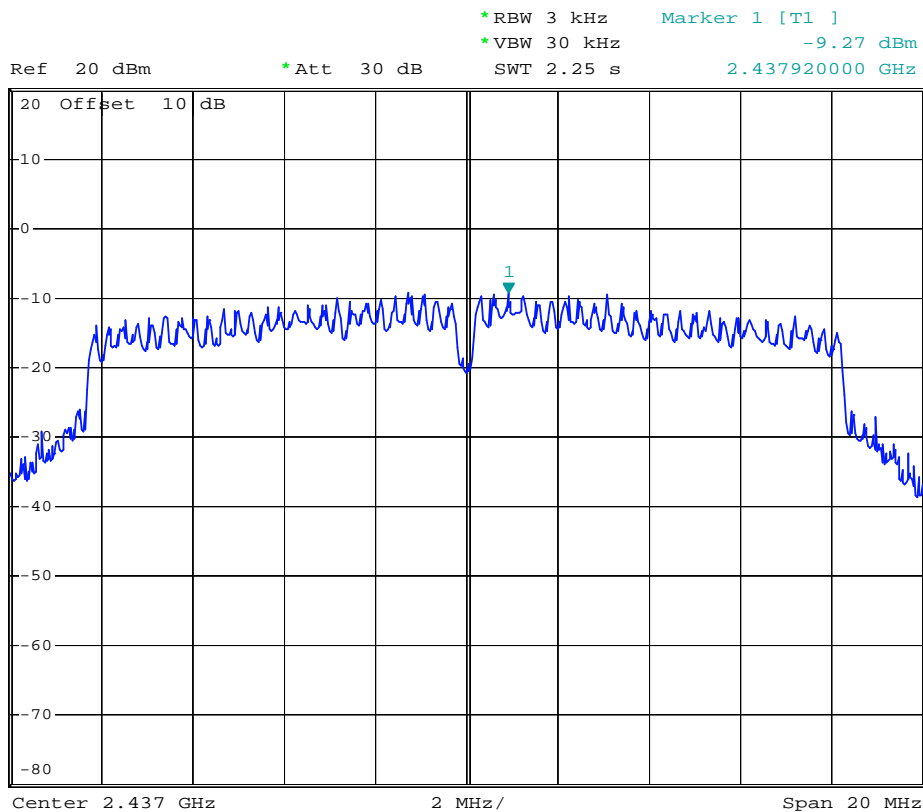

### CH No. 11 (2462 MHz)

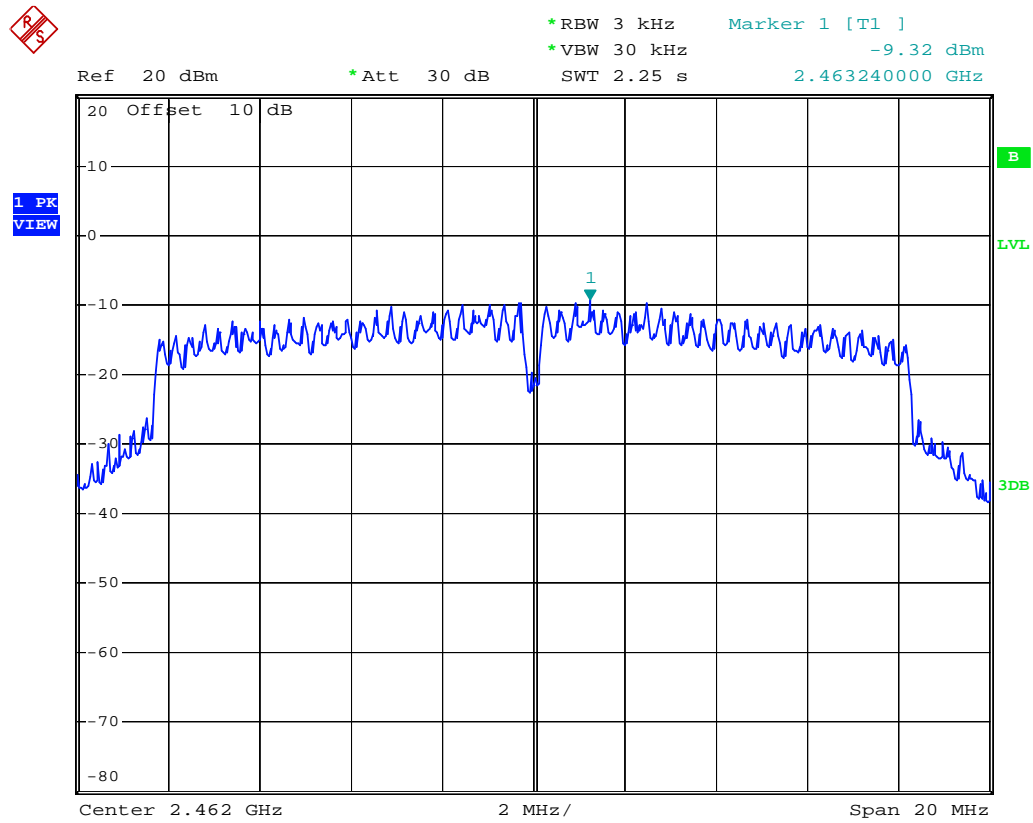

### 802.11n (20MHz; data rate: MCS0) CH No. 1 (2412 MHz)

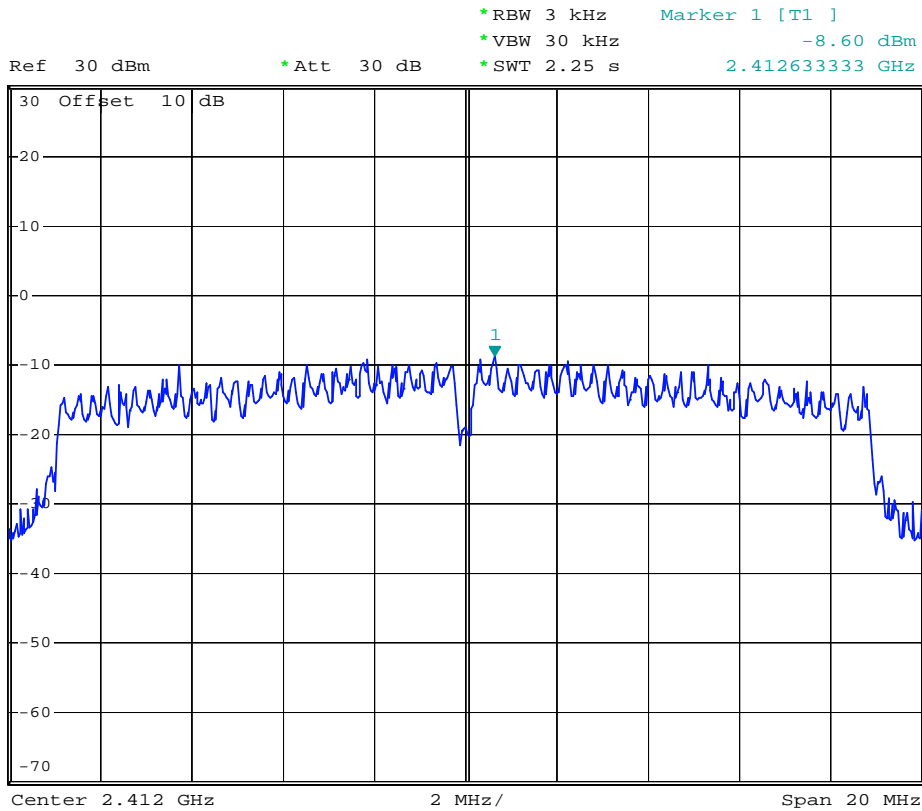

### CH No. 6 (2437 MHz)

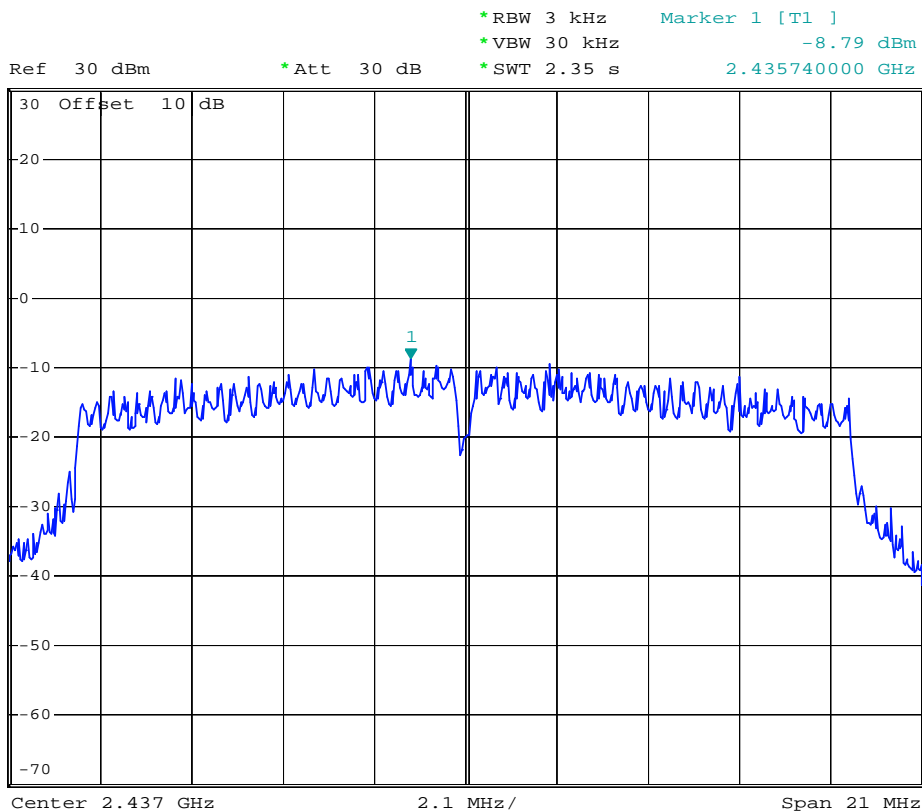

### CH No. 11 (2462 MHz)



\*RBW 3 kHz    Marker 1 [T1 ]  
\*VBW 30 kHz    -7.33 dBm  
\*SWT 2.25 s    2.460733333 GHz

Ref 30 dBm

\*Att 30 dB

1 PK  
VIEW

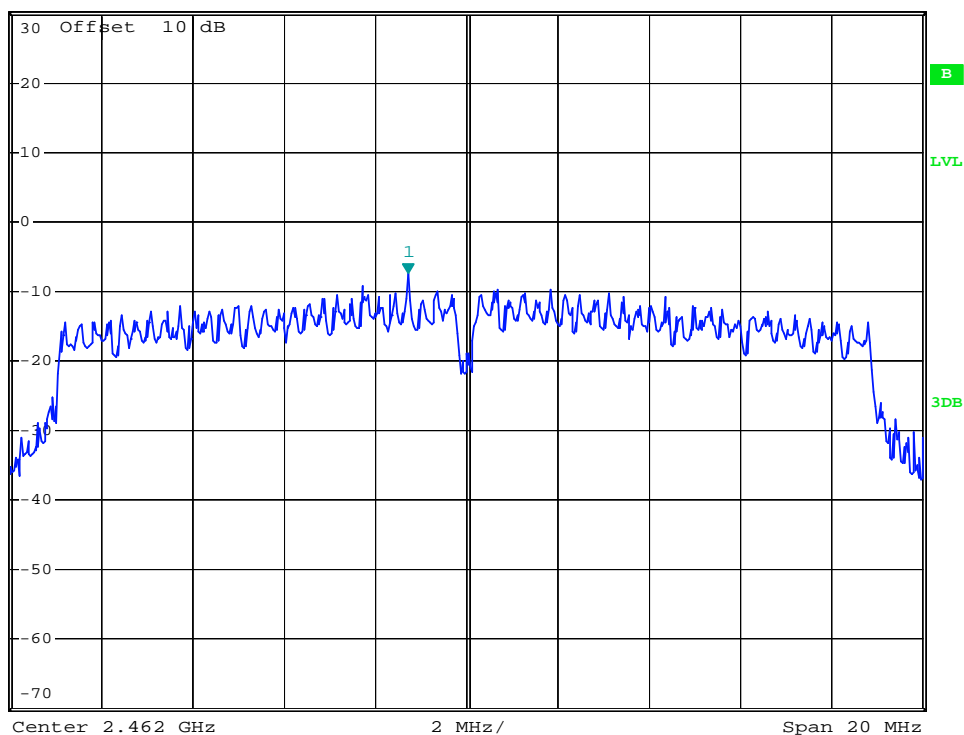

## 7 Emission on the Band Edge test

### 7.1 Limit

In any 100kHz bandwidth outside the frequency band in which the spread spectrum intentional radiator is operating, the radio frequency power that is produced by the intentional radiator shall be at least 20 dB below that in the 100 KHz bandwidth within the band that contains the highest level of the desired power, based on either an RF conducted or a radiated measurement.

### 7.2 Configuration of Measurement

Radiated measurement

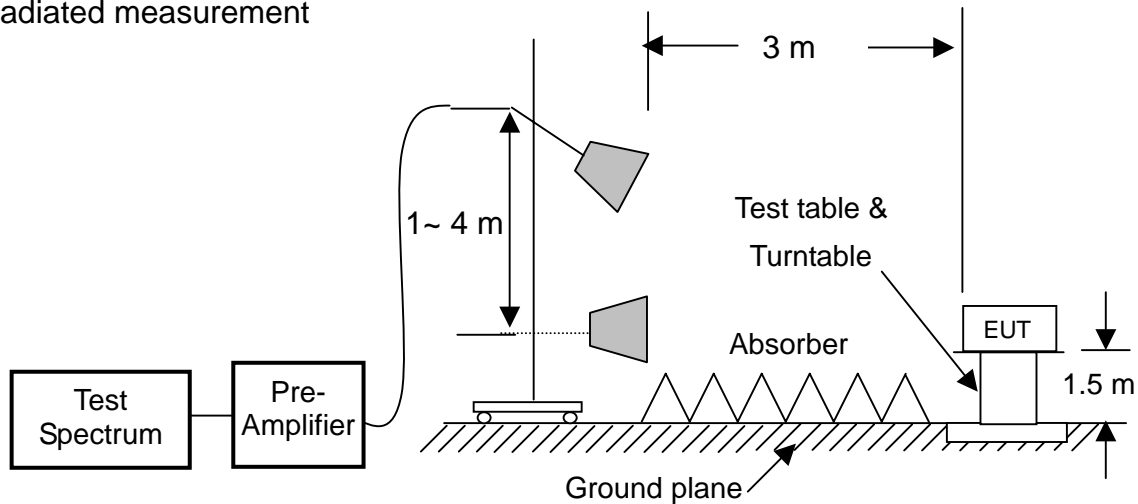

Conducted measurement

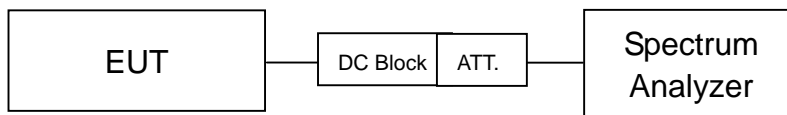

### 7.3 Test Procedure

The EUT was setup to ANSI C63.10, 2013; tested to DTS test procedure of August 24, 2018 KDB558074 D01 for compliance to FCC 47CFR 15.247 requirements.

Set RBW =1MHz, VBW= RBW for peak, and RBW =1MHz, VBW=10Hz for average.

The EUT for testing is arranged on a wooden turntable. If some peripherals apply to the EUT, the peripherals will be connected to EUT and the whole system. During the test, all cables were arranged to produce worst-case emissions. The signal is maximized through rotation. The height of antenna and polarization is changing constantly for exploring for maximum signal level. The height of antenna can be up to 4 meter and down to 1 meter.

### 7.4 Test Result

**PASS.**

The final test data is shown on as following pages.

## Band-edge\_Radiated

### 802.11b (data rate: CCK1M)

Test CH		Det. Mode	Reading (dBuV)	Factor (dB/m)	Maximum level (dBuV/m)	Limit (dBuV/m)	Margin (dB)	Result
CH No.	Freq. (MHz)							
1 (2412MHz)	2310~2390	PK	61.30	-11.74	49.56	74	-24.44	PASS
		AV	50.62	-11.73	38.89	54	-15.11	PASS
11 (2462MHz)	2483.5~2500	PK	62.69	-11.32	49.37	74	-24.63	PASS
		AV	53.42	-11.32	42.10	54	-11.90	PASS

### 802.11g (data rate: OFDM6M)

Test CH		Det. Mode	Reading (dBuV)	Factor (dB/m)	Maximum level (dBuV/m)	Limit (dBuV/m)	Margin (dB)	Result
CH No.	Freq. (MHz)							
1 (2412MHz)	2310~2390	PK	74.40	-11.73	62.67	74	-11.33	PASS
		AV	50.14	-11.71	38.43	54	-15.57	PASS
11 (2462MHz)	2483.5~2500	PK	78.66	-11.34	67.32	74	-6.68	PASS
		AV	63.46	-11.34	52.12	54	-1.88	PASS

### 802.11n (20MHz; data rate: MCS0)

Test CH		Det. Mode	Reading (dBuV)	Factor (dB/m)	Maximum level (dBuV/m)	Limit (dBuV/m)	Margin (dB)	Result
CH No.	Freq. (MHz)							
1 (2412MHz)	2310~2390	PK	78.06	-11.73	66.33	74	-7.67	PASS
		AV	59.29	-11.72	47.57	54	-6.43	PASS
11 (2462MHz)	2483.5~2500	PK	83.89	-11.34	72.55	74	-1.45	PASS
		AV	63.37	-11.34	52.03	54	-1.97	PASS

Remark : Maximum Level = Reading + Factor  
 Factor = Antenna Factor + Cable Loss - Preamp  
 Margin = Maximum level - Limit

CLIENT: Medical Intubation Technology Corp.  
 EUT: Wi-Fi 4.9mm Dual Cameras Videoscope  
 MODEL: W1149  
 RATING: DC 5 V  
 COMMENT: 802.11b CH1 2412MHz

OPERATOR : Ivan  
 TEST SITE : Chamber 3  
 TEST DISTANCE : 3m  
 POLARIZATION : VERTICAL  
 TEMP/HUM : 24°C/53%

Data:8

2018-09-03

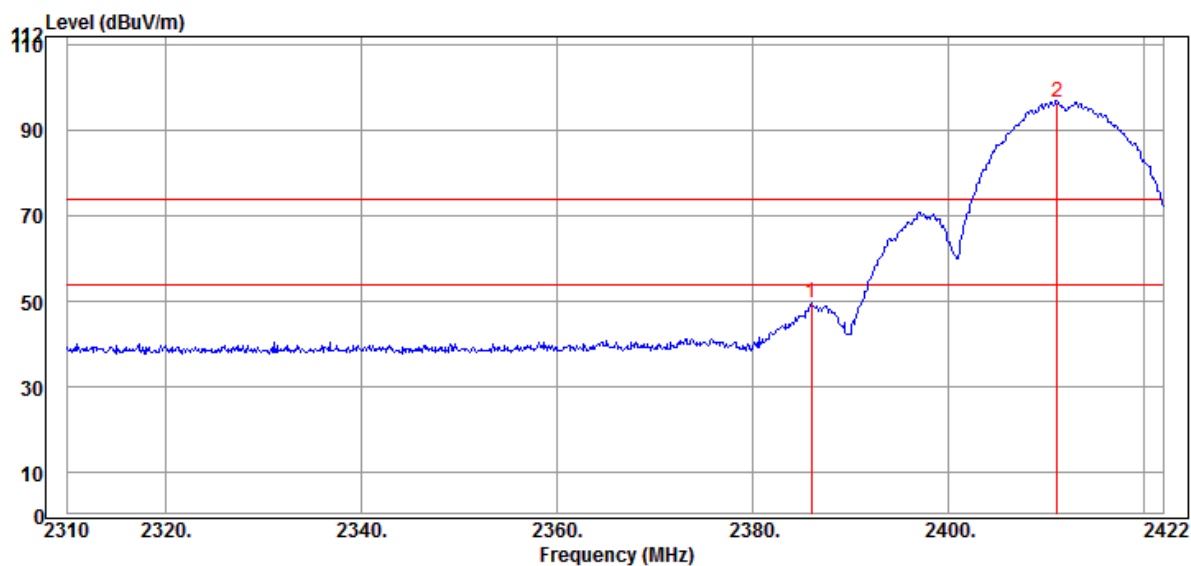

Item Mark	Freq. MHz	Reading dBuV	Factor dB/m	Level dBuV/m	Limit dBuV/m	Margin dB	Remark
1	2386.048	61.30	-11.74	49.56	74.00	-24.44	Peak
* 2	2411.136	108.23	-11.63	96.60	74.00	22.60	Peak

CLIENT: Medical Intubation Technology Corp.  
 EUT: Wi-Fi 4.9mm Dual Cameras Videoscope  
 MODEL: W1149  
 RATING: DC 5 V  
 COMMENT: 802.11b CH1 2412MHz

OPERATOR : Ivan  
 TEST SITE : Chamber 3  
 TEST DISTANCE : 3m  
 POLARIZATION : VERTICAL  
 TEMP/HUM : 24°C/53%

Data:9

2018-09-03

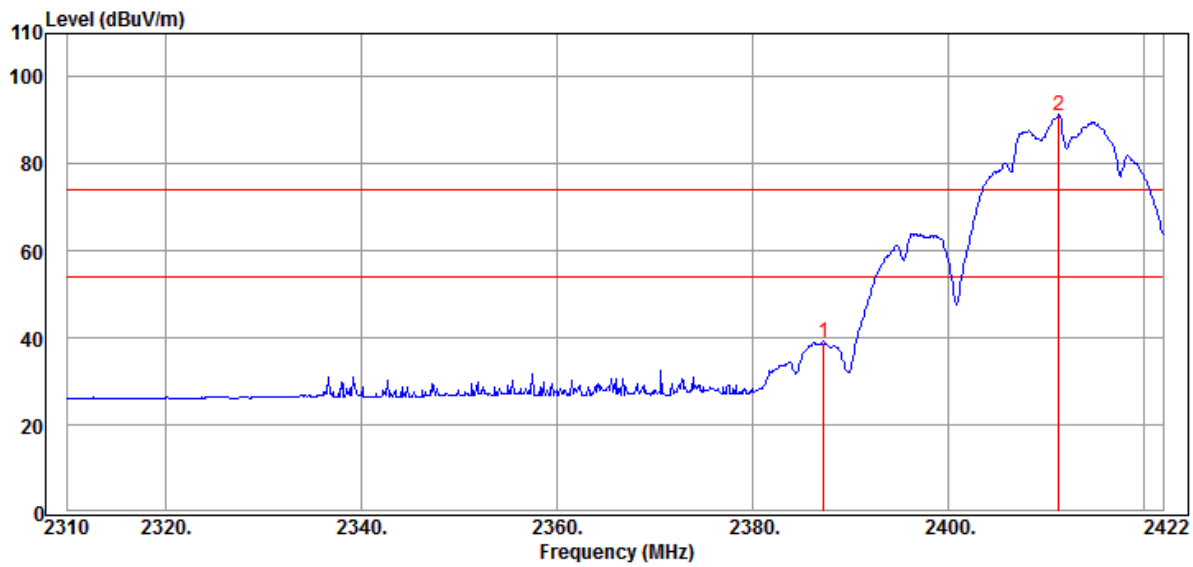

Item Mark	Freq. MHz	Reading dBuV	Factor dB/m	Level dBuV/m	Limit dBuV/m	Margin dB	Remark
1	2387.280	50.62	-11.73	38.89	54.00	-15.11	Average
* 2	2411.360	102.73	-11.63	91.10	54.00	37.10	Average



CLIENT: Medical Intubation Technology Corp.  
 EUT: Wi-Fi 4.9mm Dual Cameras Videoscope  
 MODEL: W1149  
 RATING: DC 5 V  
 COMMENT: 802.11b CH11 2462MHz

OPERATOR : Ivan  
 TEST SITE : Chamber 3  
 TEST DISTANCE : 3m  
 POLARIZATION : VERTICAL  
 TEMP/HUM : 24°C/53%

Data:10

2018-09-03

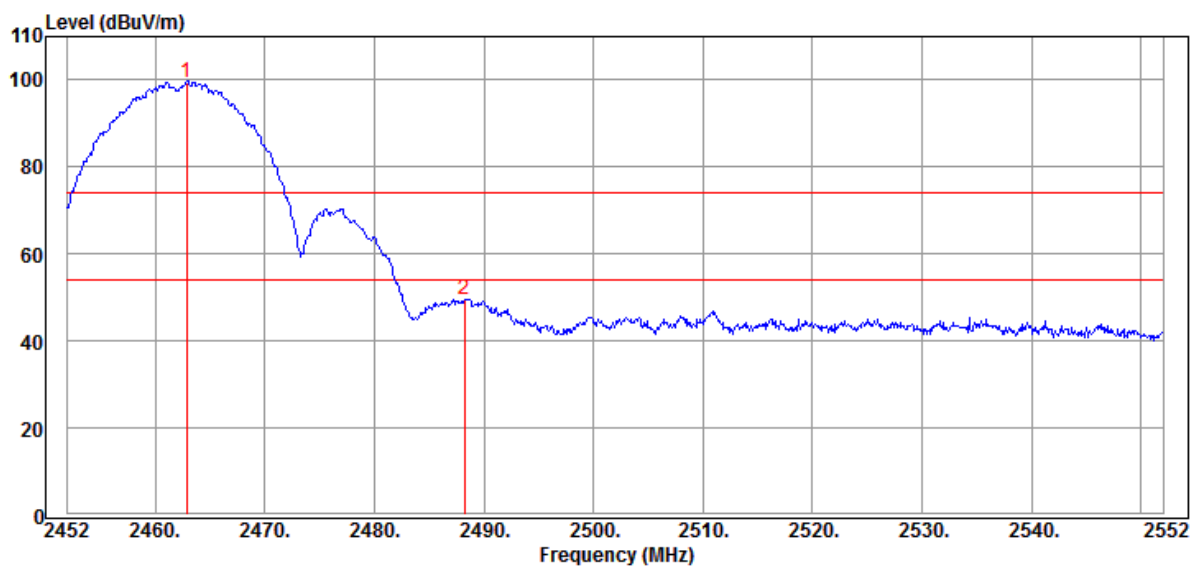

Item Mark	Freq. MHz	Reading dBuV	Factor dB/m	Level dBuV/m	Limit dBuV/m	Margin dB	Remark	
*	1	2462.900	110.94	-11.42	99.52	74.00	25.52	Peak
	2	2488.200	60.69	-11.32	49.37	74.00	-24.63	Peak

CLIENT: Medical Intubation Technology Corp.  
 EUT: Wi-Fi 4.9mm Dual Cameras Videoscope  
 MODEL: W1149  
 RATING: DC 5 V  
 COMMENT: 802.11b CH11 2462MHz

OPERATOR : Ivan  
 TEST SITE : Chamber 3  
 TEST DISTANCE : 3m  
 POLARIZATION : VERTICAL  
 TEMP/HUM : 24°C/53%

Data:11

2018-09-03

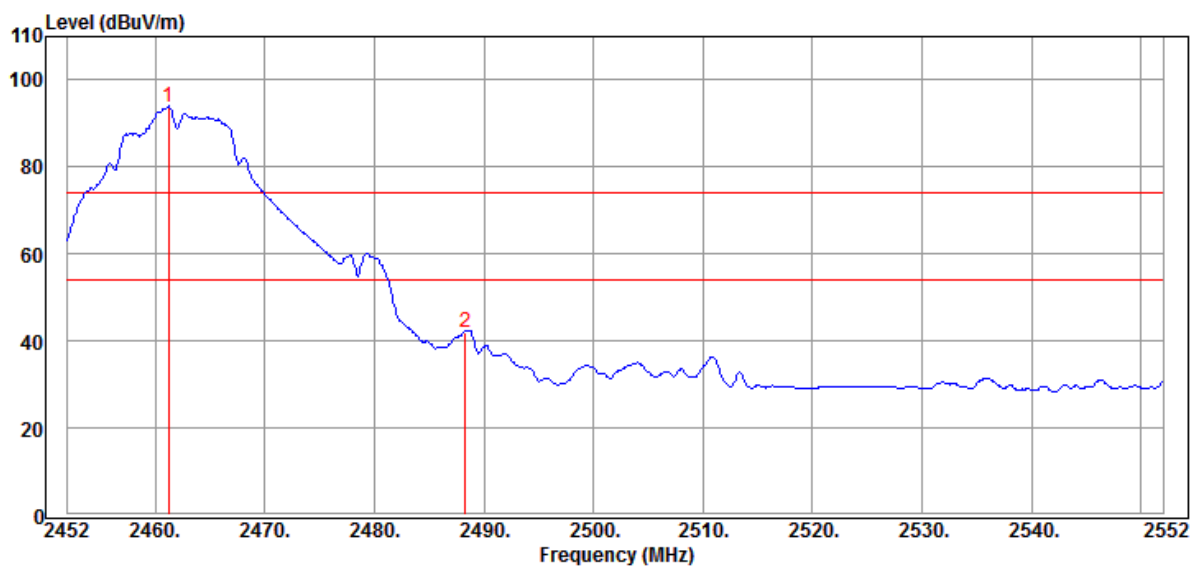

Item Mark	Freq. MHz	Reading dBuV	Factor dB/m	Level dBuV/m	Limit dBuV/m	Margin dB	Remark	
*	1	2461.200	105.17	-11.43	93.74	54.00	39.74	Average
	2	2488.300	53.42	-11.32	42.10	54.00	-11.90	Average

CLIENT: Medical Intubation Technology Corp.  
 EUT: Wi-Fi 4.9mm Dual Cameras Videoscope  
 MODEL: W1149  
 RATING: DC 5 V  
 COMMENT: 802.11g CH1 2412MHz

OPERATOR : Ivan  
 TEST SITE : Chamber 3  
 TEST DISTANCE : 3m  
 POLARIZATION : VERTICAL  
 TEMP/HUM : 24°C/53%

Data:12

2018-09-03

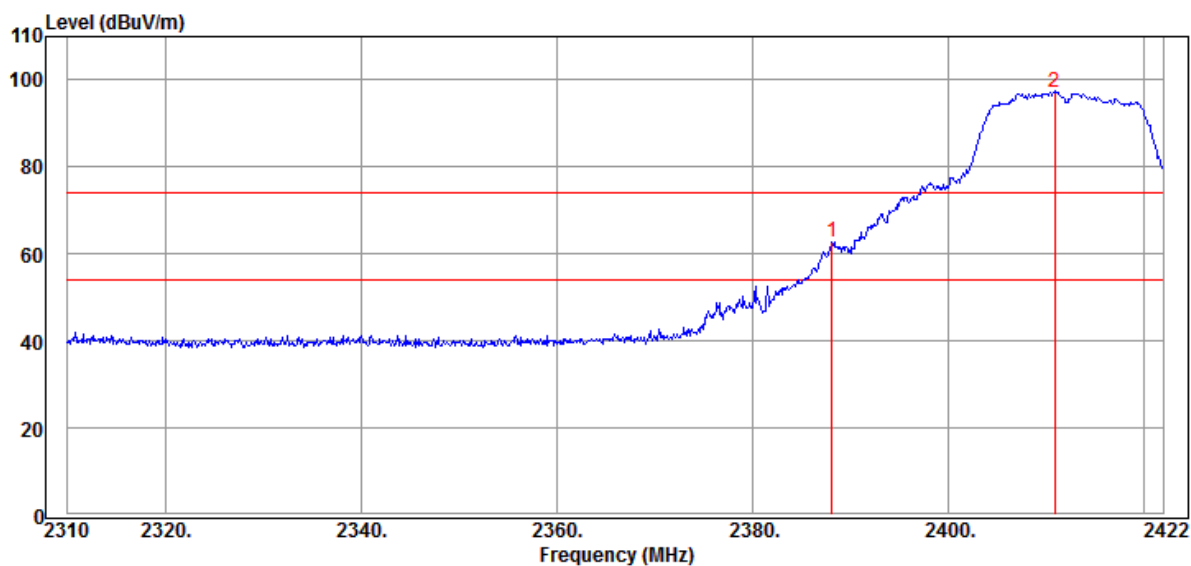

Item Mark	Freq. MHz	Reading dBuV	Factor dB/m	Level dBuV/m	Limit dBuV/m	Margin dB	Remark
1	2388.176	74.40	-11.73	62.67	74.00	-11.33	Peak
* 2	2410.912	108.80	-11.63	97.17	74.00	23.17	Peak

CLIENT: Medical Intubation Technology Corp.  
 EUT: Wi-Fi 4.9mm Dual Cameras Videoscope  
 MODEL: W1149  
 RATING: DC 5 V  
 COMMENT: 802.11g CH1 2412MHz

OPERATOR : Ivan  
 TEST SITE : Chamber 3  
 TEST DISTANCE : 3m  
 POLARIZATION : VERTICAL  
 TEMP/HUM : 24°C/53%

Data:13

2018-09-03

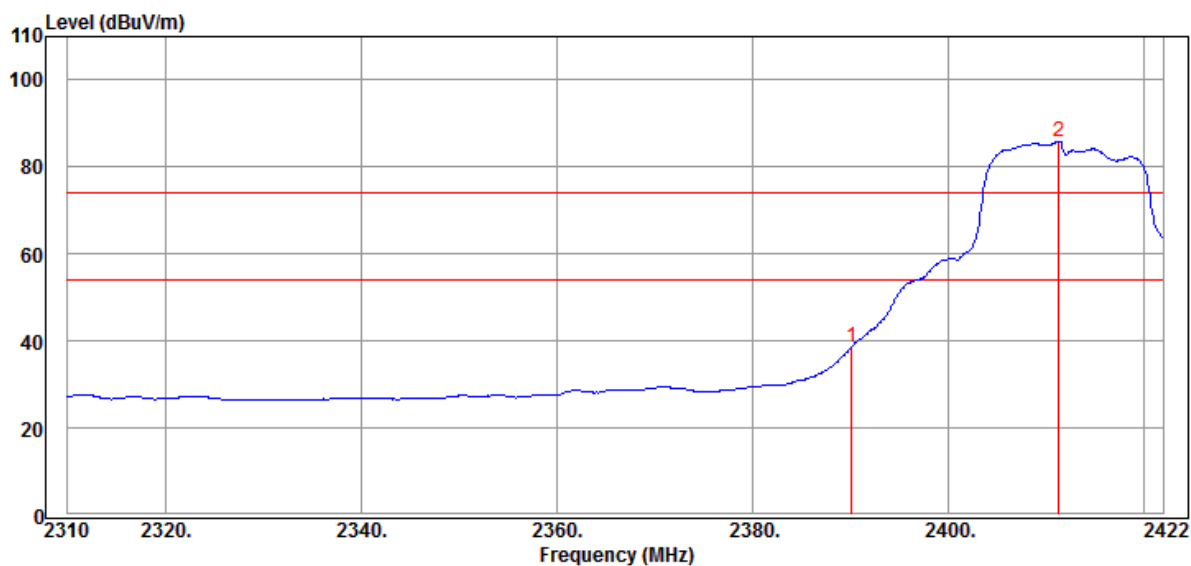

Item Mark	Freq. MHz	Reading dBuV	Factor dB/m	Level dBuV/m	Limit dBuV/m	Margin dB	Remark
1	2390.192	50.14	-11.71	38.43	54.00	-15.57	Average
* 2	2411.360	97.25	-11.63	85.62	54.00	31.62	Average

CLIENT: Medical Intubation Technology Corp.  
 EUT: Wi-Fi 4.9mm Dual Cameras Videoscope  
 MODEL: W1149  
 RATING: DC 5 V  
 COMMENT: 802.11g CH11 2462MHz

OPERATOR : Ivan  
 TEST SITE : Chamber 3  
 TEST DISTANCE : 3m  
 POLARIZATION : VERTICAL  
 TEMP/HUM : 24°C/53%

Data:14

2018-09-03

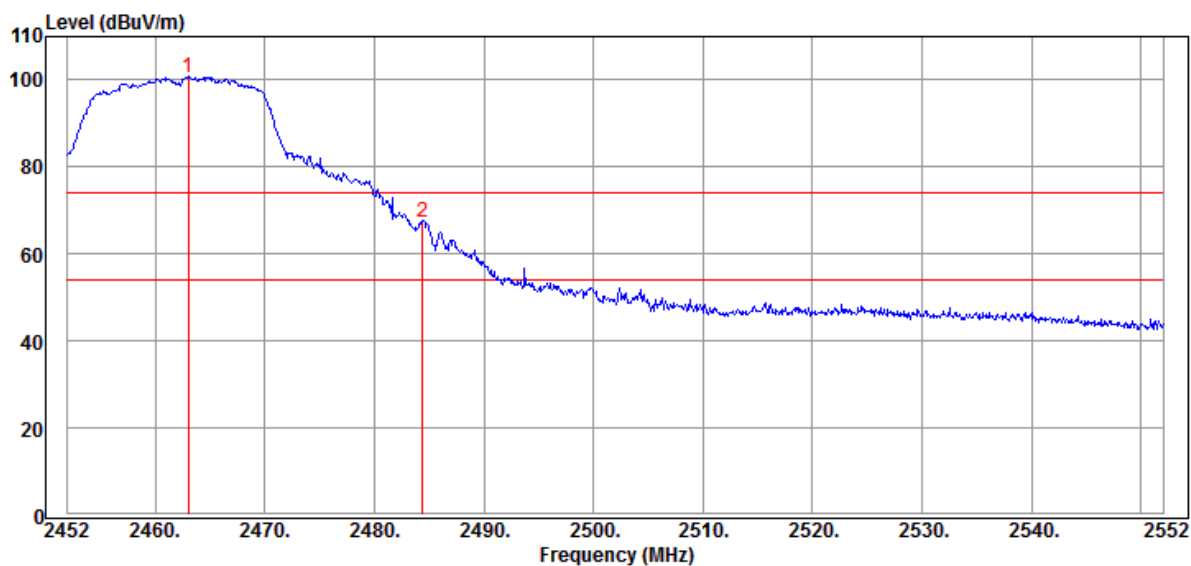

Item Mark	Freq. MHz	Reading dBuV	Factor dB/m	Level dBuV/m	Limit dBuV/m	Margin dB	Remark	
*	1	2463.000	111.92	-11.42	100.50	74.00	26.50	Peak
	2	2484.400	78.66	-11.34	67.32	74.00	-6.68	Peak

CLIENT: Medical Intubation Technology Corp.  
 EUT: Wi-Fi 4.9mm Dual Cameras Videoscope  
 MODEL: W1149  
 RATING: DC 5 V  
 COMMENT: 802.11g CH11 2462MHz

OPERATOR : Ivan  
 TEST SITE : Chamber 3  
 TEST DISTANCE : 3m  
 POLARIZATION : VERTICAL  
 TEMP/HUM : 24°C/53%

Data:15

2018-09-03

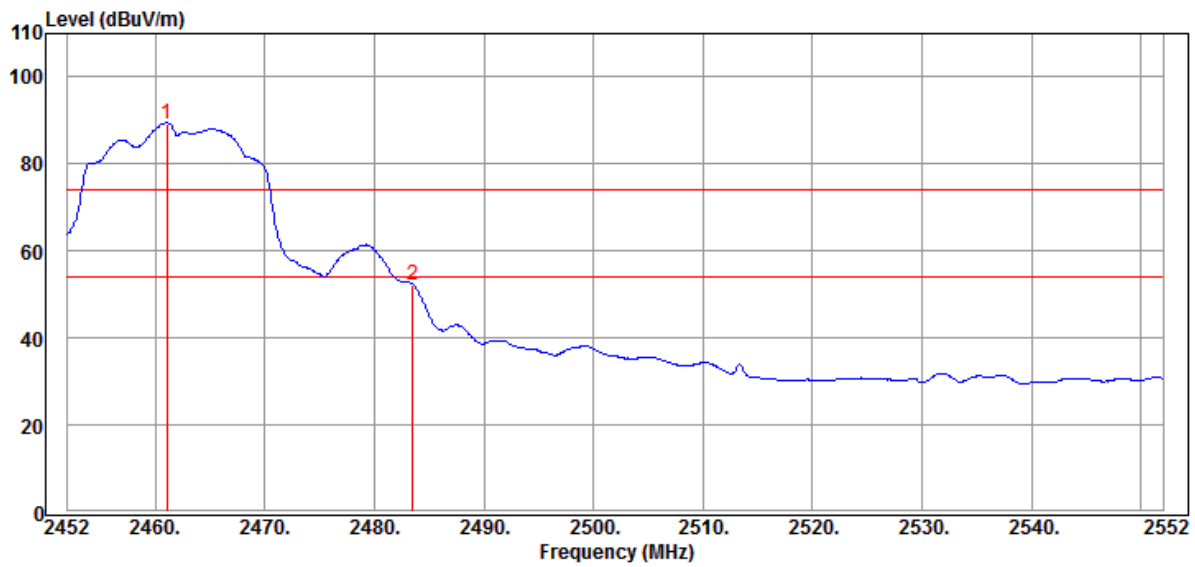

Item Mark	Freq. MHz	Reading dBuV	Factor dB/m	Level dBuV/m	Limit dBuV/m	Margin dB	Remark	
*	1	2461.100	100.60	-11.43	89.17	54.00	35.17	Average
	2	2483.500	63.46	-11.34	52.12	54.00	-1.88	Average

CLIENT: Medical Intubation Technology Corp.  
 EUT: Wi-Fi 4.9mm Dual Cameras Videoscope  
 MODEL: W1149  
 RATING: DC 5 V  
 COMMENT: 802.11n CH1 2412MHz

OPERATOR : Ivan  
 TEST SITE : Chamber 3  
 TEST DISTANCE : 3m  
 POLARIZATION : VERTICAL  
 TEMP/HUM : 24°C/53%

Data:16

2018-09-03

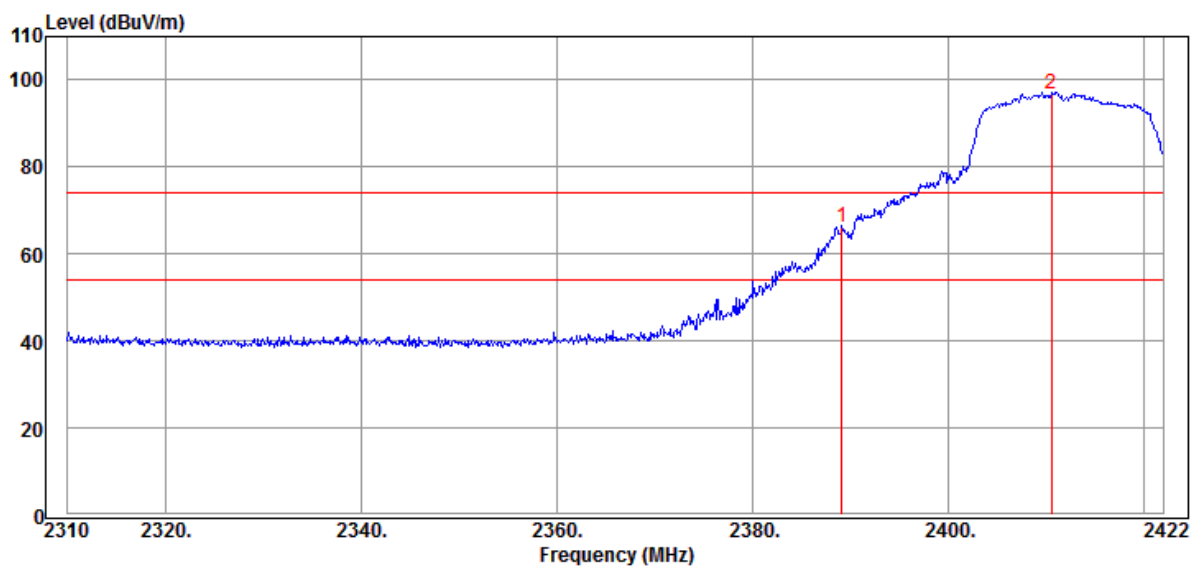

Item Mark	Freq. MHz	Reading dBuV	Factor dB/m	Level dBuV/m	Limit dBuV/m	Margin dB	Remark
1	2389.184	78.06	-11.73	66.33	74.00	-7.67	Peak
* 2	2410.576	108.46	-11.63	96.83	74.00	22.83	Peak

CLIENT: Medical Intubation Technology Corp.  
 EUT: Wi-Fi 4.9mm Dual Cameras Videoscope  
 MODEL: W1149  
 RATING: DC 5 V  
 COMMENT: 802.11n CH1 2412MHz

OPERATOR : Ivan  
 TEST SITE : Chamber 3  
 TEST DISTANCE : 3m  
 POLARIZATION : VERTICAL  
 TEMP/HUM : 24°C/53%

Data:17

2018-09-03

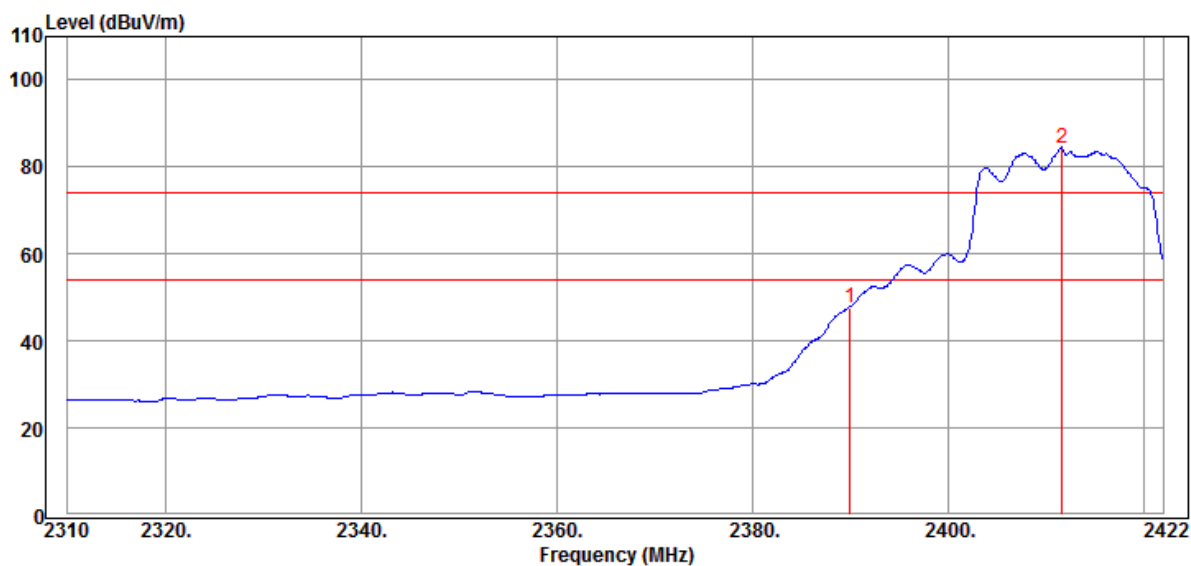

Item Mark	Freq. MHz	Reading dBuV	Factor dB/m	Level dBuV/m	Limit dBuV/m	Margin dB	Remark
1	2389.968	59.29	-11.72	47.57	54.00	-6.43	Average
* 2	2411.696	95.86	-11.62	84.24	54.00	30.24	Average



CLIENT: Medical Intubation Technology Corp.  
 EUT: Wi-Fi 4.9mm Dual Cameras Videoscope  
 MODEL: W1149  
 RATING: DC 5 V  
 COMMENT: 802.11n CH11 2462MHz

OPERATOR : Ivan  
 TEST SITE : Chamber 3  
 TEST DISTANCE : 3m  
 POLARIZATION : VERTICAL  
 TEMP/HUM : 24°C/53%

Data:18

2018-09-03

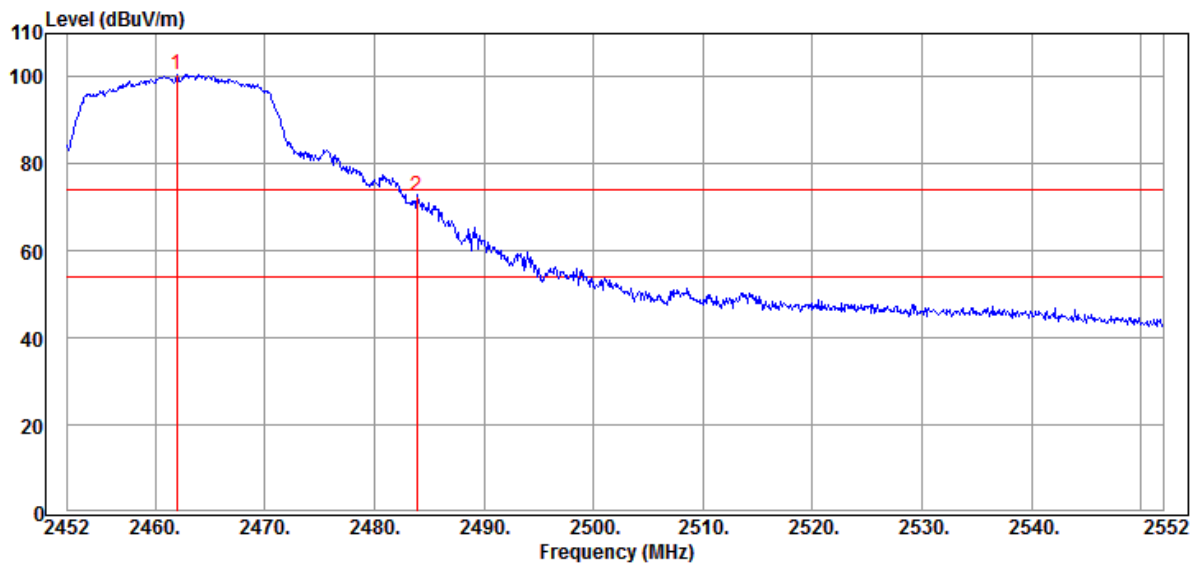

Item Mark	Freq. MHz	Reading dBuV	Factor dB/m	Level dBuV/m	Limit dBuV/m	Margin dB	Remark	
*	1	2462.000	111.87	-11.42	100.45	74.00	26.45	Peak
	2	2483.900	83.89	-11.34	72.55	74.00	-1.45	Peak

CLIENT: Medical Intubation Technology Corp.  
 EUT: Wi-Fi 4.9mm Dual Cameras Videoscope  
 MODEL: W1149  
 RATING: DC 5 V  
 COMMENT: 802.11n CH11 2462MHz

OPERATOR : Ivan  
 TEST SITE : Chamber 3  
 TEST DISTANCE : 3m  
 POLARIZATION : VERTICAL  
 TEMP/HUM : 24°C/53%

Data:20

2018-09-03

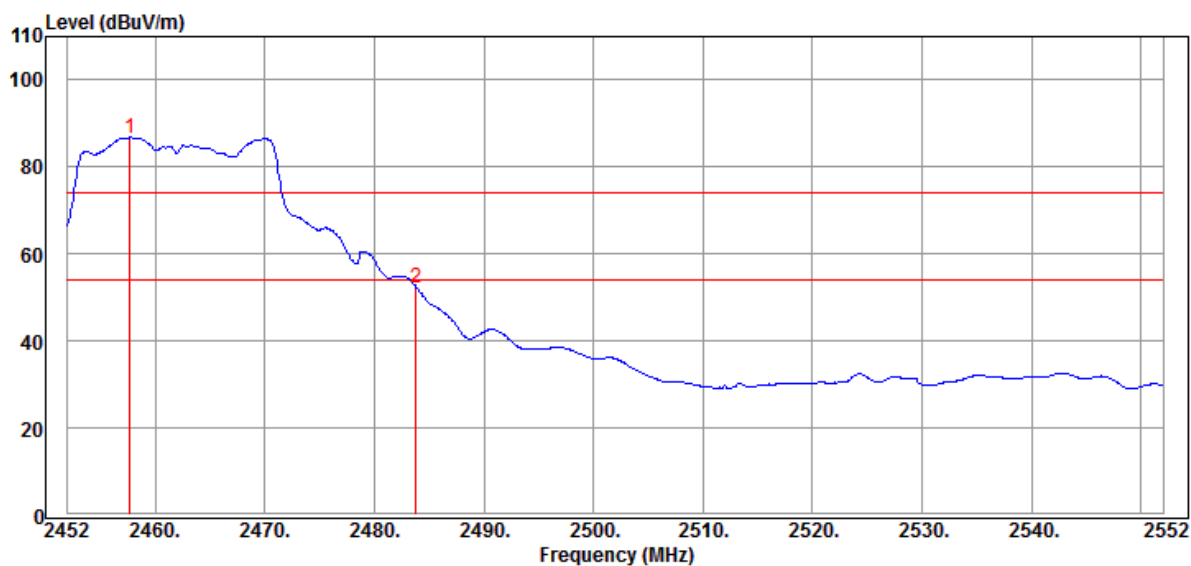

Item Mark	Freq. MHz	Reading dBuV	Factor dB/m	Level dBuV/m	Limit dBuV/m	Margin dB	Remark	
*	1	2457.700	97.94	-11.44	86.50	54.00	32.50	Average
	2	2483.800	63.37	-11.34	52.03	54.00	-1.97	Average

## Band-edge\_Conducted

### 802.11b (data rate: CCK1M)

Test CH		Detector Mode	Measure Result (dBm)	Limit (dBm)	Margin (dB)	Result
CH No.	Freq. (MHz)					
1	Marker 1: 2396.97	PK	-25.21	-10.45	-14.76	PASS
11	Marker 1: 2484.60	PK	-46.51	-11.6	-34.91	PASS

### 802.11g (data rate: OFDM6M)

Test CH		Detector Mode	Measure Result (dBm)	Limit (dBm)	Margin (dB)	Result
CH No.	Freq. (MHz)					
1	Marker 1: 2398.33	PK	-20.48	-13.89	-6.59	PASS
11	Marker 1: 2486.00	PK	-38.84	-13.93	-24.91	PASS

### 802.11n (20MHz; data rate: MCS0)

Test CH		Detector Mode	Measure Result (dBm)	Limit (dBm)	Margin (dB)	Result
CH No.	Freq. (MHz)					
1	Marker 1: 2398.50	PK	-20.49	-11.81	-8.68	PASS
11	Marker 1: 2484.50	PK	-34.00	-12.1	-21.9	PASS

Remark : Margin = Measure Result - Limit

### 802.11b CH1 2412MHz

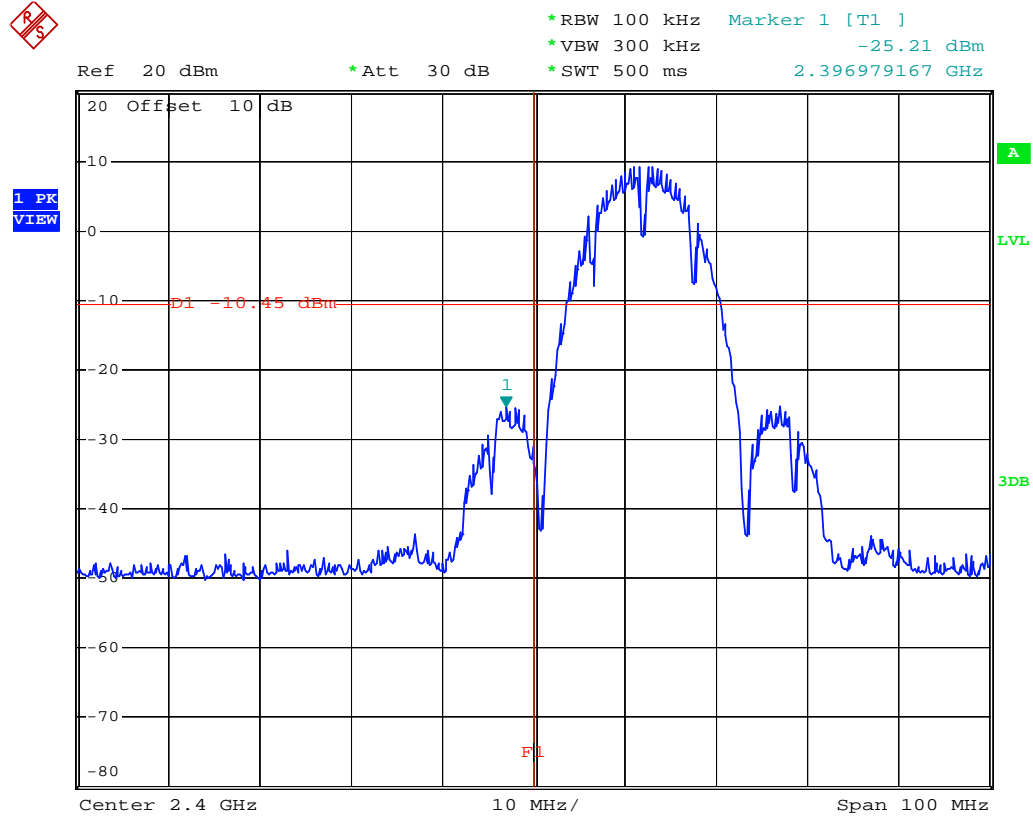

### 802.11b CH11 2462MHz

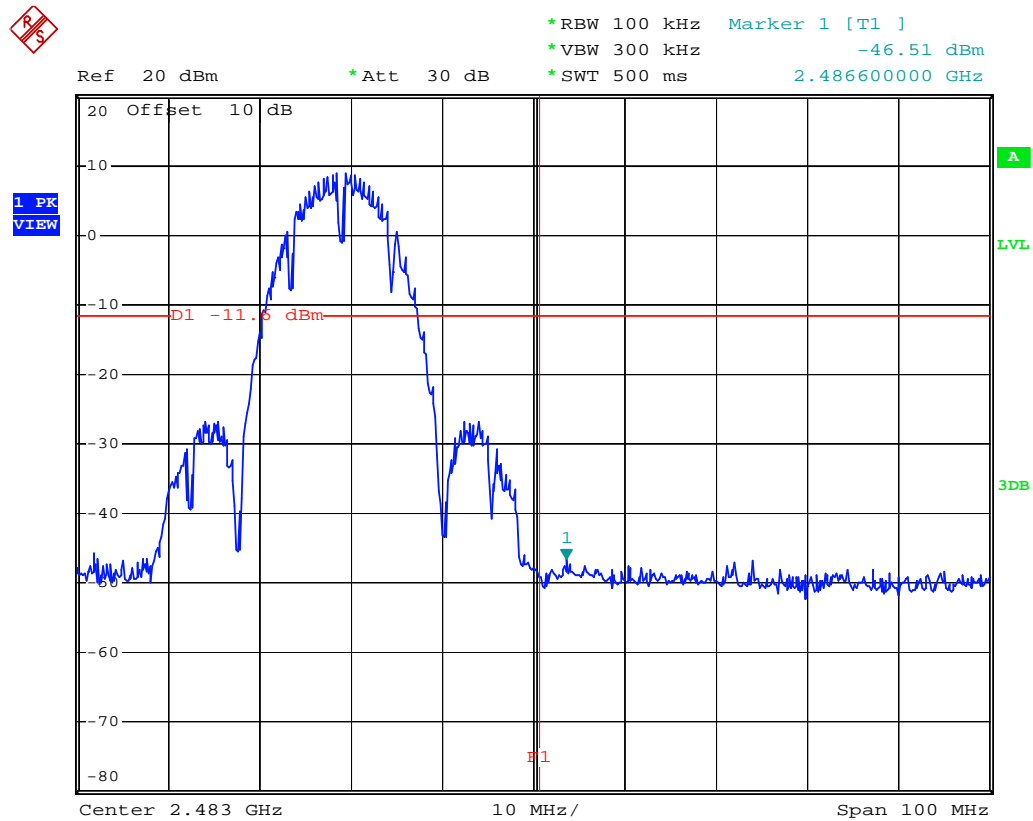

### 802.11g CH1 2412MHz

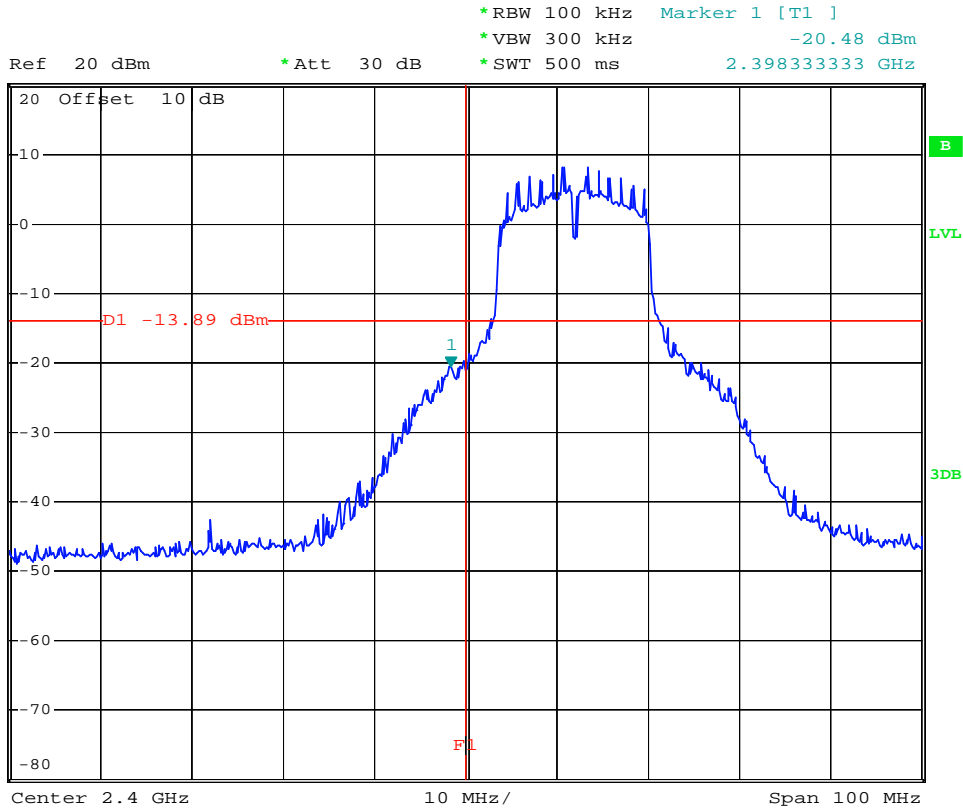

### 802.11g CH11 2462MHz

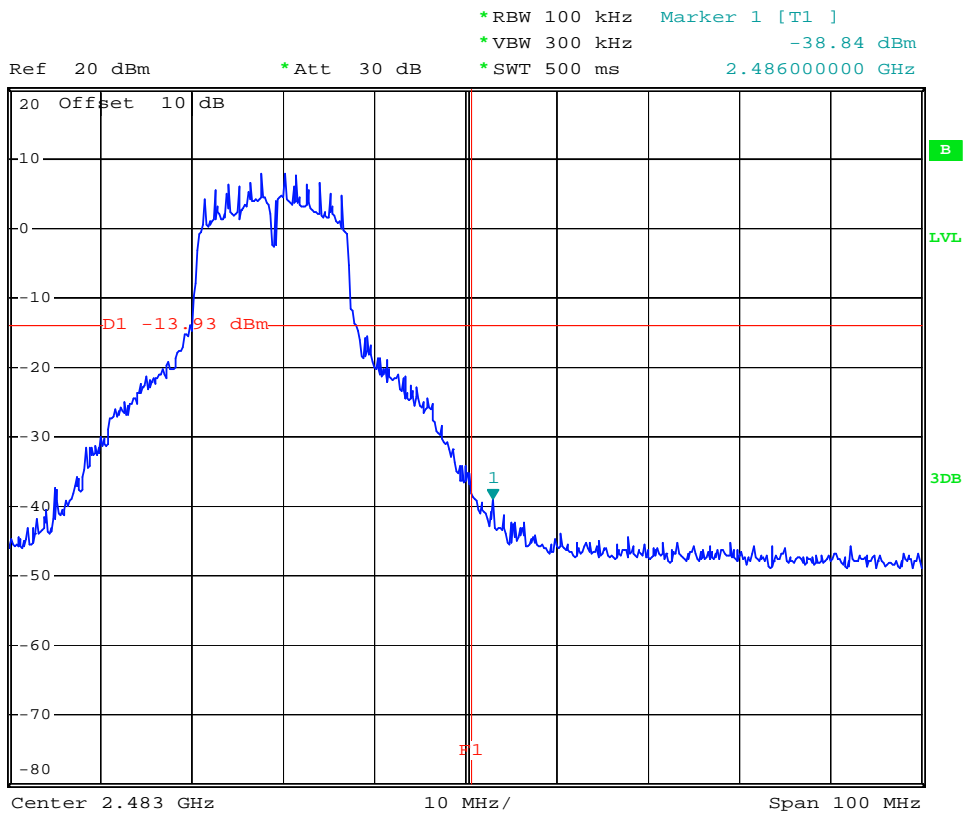

### 802.11n CH1 2412MHz

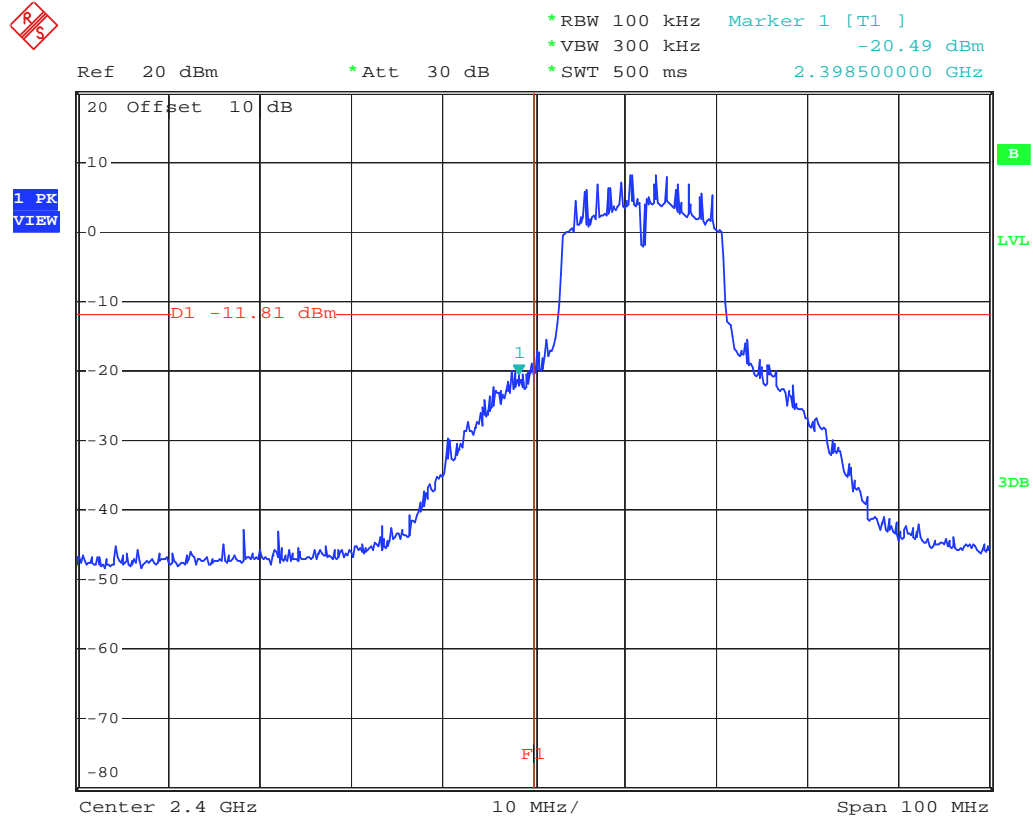

### 802.11n CH11 2462MHz

