

CFR 47 FCC Part 15.249 & RSS-210 Issue 8 TEST REPORT

Product : **M3 VIDEOSCOPE SYSTEM**

Trade Name : Mitcorp

Model Number : R1000

FCC ID : 2AA5F-R1000

Prepared for

Medical Intubation Technology Corp.

2F, No. 75, Wenhwa 1 st. Rd., Lohshan Vill., Kueishan, Taoyuan County 333,
Taiwan

TEL. : +886 3 328 7177

FAX. : +886 3 328 7176

Prepared by

Interocean EMC Technology Corp.

No. 5-2, Lin 1, Tin-Fu, Lin-Kou Dist., New Taipei City,
Taiwan 244, R.O.C.

TEL.: +886 2 2600 6861

FAX.: +886 2 2600 6859

Remark :

The test report consists of **32** pages in total. It shall not be reproduced except in full, without the written approval of IETC. This document may be altered or revised by IETC only, and shall be noted in the revision section of the document.
The test result in this report is only subjected to the test sample.

Table of Contents

1	General Information	4
1.1	Description of Equipment Under Test	4
1.2	Table for Carrier Frequencies	5
1.3	Test Facility	6
1.4	Test Equipment	7
1.5	Summary of Measurement	8
2	Bandwidth test	9
2.1	Limit	9
2.2	Configuration of Measurement	9
2.3	Test Procedure	9
2.4	Test Result	9
3	RF Radiated spurious emission test	14
3.1	Limit	14
3.2	Configuration of Measurement	14
3.3	Test Procedure	15
3.4	The description of operation mode	15
3.5	Test Result	15
4	Emission on the Band Edge test	20
4.1	Limit	20
4.2	Configuration of Measurement	20
4.3	Test Procedure	20
4.4	Test Result	20
5	Photographs of Test	24
5.1	Radiated Emission Measurement	24
6	Photographs of EUT	28

Statement of Compliance

Applicant: Medical Intubation Technology Corp.

Manufacturer: Medical Intubation Technology Corp.

Product: M3 VIDEOSCOPE SYSTEM

Model No.: R1000

Tested Power Supply: DC 3V

Date of Final Test: Dec. 05, 2013

Revision of Report: Rev. 03

Configuration of Measurements and Standards Used :

FCC Rules and Regulations Part 15 Subpart C

RSS-210 Issue 8

I HEREBY CERTIFY THAT: The data shown in this report were made in accordance with the procedures given in ANSI C63.4, and the energy emitted by the device was founded to be within the limits applicable. I assume full responsibility for accuracy and completeness of these data.

Note: 1. The result of the testing report relate only to the item tested.

2. The testing report shall not be reproduced expect in full, without the written approval of IETC

Report Issued: 2014/02/06

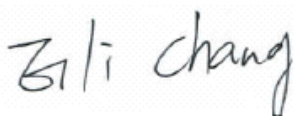
Project Engineer: 
Elli Chang

Approved: 
Jerry Liu

1 General Information

1.1 Description of Equipment Under Test

Product : M3 VIDEOSCOPE SYSTEM

Model Number : R1000

Applicant : **Medical Intubation Technology Corp.**
2F, No. 75, Wenhwa 1 st. Rd., Lohshan Vill., Kueishan,
Taoyuan County 333, Taiwan

Manufacturer : **Medical Intubation Technology Corp.**
2F, No. 75, Wenhwa 1 st. Rd., Lohshan Vill., Kueishan,
Taoyuan County 333, Taiwan

Operating Frequency : 2425.75MHz ~ 2475.75MHz

Channel Number : Refer to section 1.2

Type of Modulation : MSK

Antenna description : This device uses Chip antenna,
Antenna Gain: 4 dBi

Date of Test : Nov. 20 ~ Dec. 05, 2013

Additional Description : 1.) The model "R1000" is representative selected in the test and included in this report.
2.) For more detail specification about EUT, please refer to the user's manual.

1.2 Table for Carrier Frequencies

CH No.	1	2	3
CF (MHz)	2425.75	2450.75	2475.75

1.3 Test Facility

- Site Description** : ☑OATS 1 ☑RF Room
- Name of Firm** : Interocean EMC Technology Corp.
- Company web** : <http://www.ietc.com.tw>
- Location** : No. 5-2, Lin 1, Tin-Fu, Lin-Kou Dist., New Taipei City, Taiwan 244, R.O.C.
- Site Filing** :
- Federal Communication Commissions – USA
Registration No.: 96399 (OATS 1 & 2)
Registration No.: 518958 (OATS 3)
Designation No.: TW1020
 - Voluntary Control Council for Interference by Information Technology Equipment (VCCI) – Japan
Member No.: 1349
Registration No. (Conducted Room): C-1094
Registration No. (Conducted Room): T-1562
Registration No. (OATS 1): R-1040; G-274
Registration No. (OATS 2): R-1041
 - Industry Canada (IC)
OUR FILE: 46405-4437 Submission: 145171
Registration No. (OATS 1): Site# 4437A-1
Registration No. (OATS 2): Site# 4437A-2
Registration No. (OATS 3): Site# 4437A-3
- Site Accreditation** :
- Bureau of Standards and Metrology and Inspection (BSMI) – Taiwan, R.O.C.
Accreditation No.:
SL2-IN-E-0026 for CNS13438 / CISPR22
SL2-R1-E-0026 for CNS13439 / CISPR13
SL2-R2-E-0026 for CNS13439 / CISPR13
SL2-A1-E-0026 for CNS13783-1 / CISPR14-1
SL2-L1-E-0026 for CNS 14115 / CISPR 15
 - Taiwan Accreditation Foundation (TAF)
Accrditation No.: 1113
 - TÜV NORD
Certificate No: TNTW0801R-04



1.4 Test Equipment

Instrument	Manufacturer	Model	Serial No.	Next Cal. Date
Spectrum Analyzer	R&S	FSP40	100478	2014/05/26
Preamplifier	Agilent	8449B	3008A01434	2014/05/07
Preamplifier	Agilent	83050A	3950A00225	2014/09/08
Horn Antenna	COM-POWER	AH-118	10081	2014/05/30
Horn Antenna	Schwarzbeck	BBHA 9120	9120D-583	2014/05/12
Horn Antenna	Schwarzbeck	BBHA 9170	213	2014/07/24
Cable	HARBOUR	27478LL142	CBL22	2014/09/26
EMI Test Receiver	Rohde & Schwarz	ESVS10	826148/011	2014/11/04
Biconical Antenna	Schwarzbeck	BBA 9106	VHA 9103-2418	2014/03/27
Log Antenna	Schwarzbeck	UHALP 9108 A	0738	2014/03/27
Pre-Amplifier	Agilent	8447D	2944A09703	2014/04/30
RF Cable	PACIFIC	CBL41	CBL41	2014/11/15
RF Cable	Mini-Circuits	CBL-3FL-NMNM	CBL56	2014/08/30
RF Cable	Insulated Wire	CBL59	CBL59	2014/01/23

Note: The above equipments are within the valid calibration period.

1.5 Summary of Measurement

Report Clause	Test Parameter	Reference Document		Results
		FCC	IC	
2	Bandwidth test	FCC 15.215	RSS-Gen 4.3	Pass
3	RF Radiated spurious emission test	FCC 15.249(a)(c)(d)	RSS-Gen RSS-210 A 2.9	Pass
4	Emission on the Band Edge	FCC 15.249(d)	RSS-Gen RSS-210 A 2.9	Pass
	AC Power Line Conducted Emission test	FCC 15.207	RSS-Gen RSS-210 A 2.9	N/A

2 Bandwidth test

2.1 Limit

According to FCC 15.215 and RSS-Gen 4.3 requirements, there was no regulation limit and for reference purpose.

2.2 Configuration of Measurement

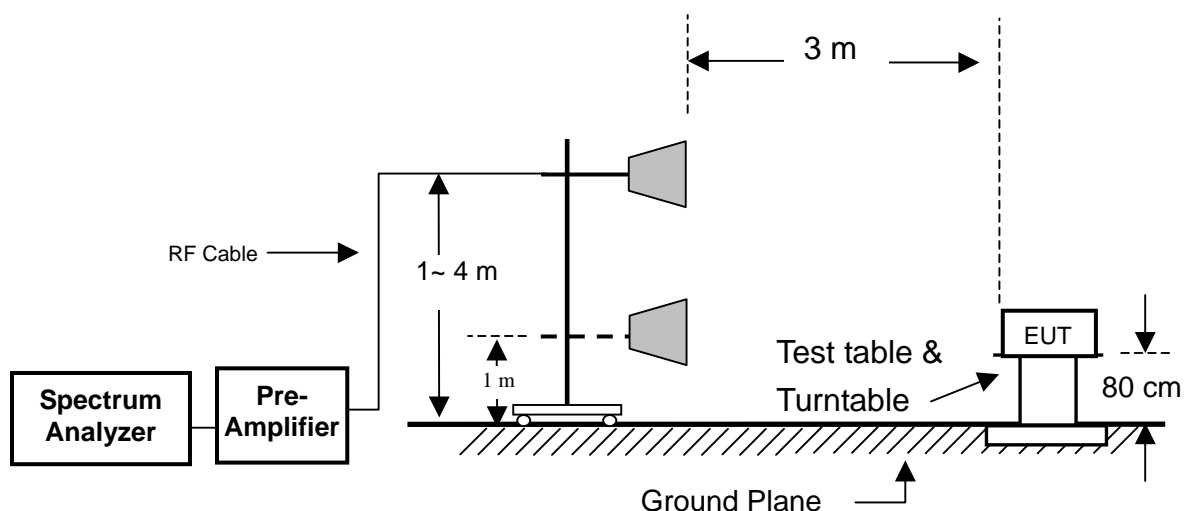

2.3 Test Procedure

20dB bandwidth:

The resolutions bandwidth set at 100 kHz, the video bandwidth \geq RBW, and the SPAN may equal to approximately 2 to 3 time the 20dB bandwidth.

Occupied bandwidth:

The resolution bandwidth shall be set to as close to 1% of the selected span as is possible without being below 1%. The video bandwidth shall be set to 3 times the resolution bandwidth.

2.4 Test Result

PASS.

The final test data is shown as following pages.

For FCC

Test CH		20dB Bandwidth (kHz)
Modulation	Frq. (MHz)	
MSK	2425.75	860.00
	2450.75	930.00
	2475.75	840.00

For IC

Test CH		99% Occupied Bandwidth (kHz)
Modulation	Frq. (MHz)	
MSK	2425.75	720.00
	2450.75	792.00
	2475.75	720.00

2425.75MHz 20dB Bandwidth

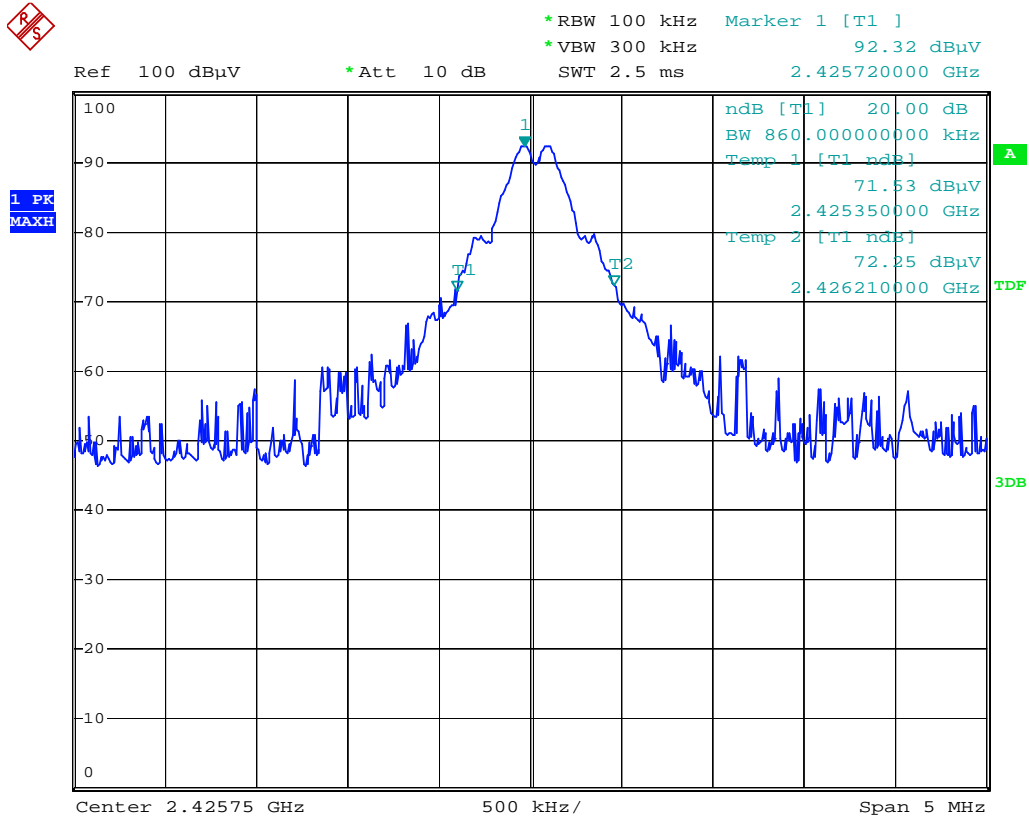

2450.75MHz 20dB Bandwidth

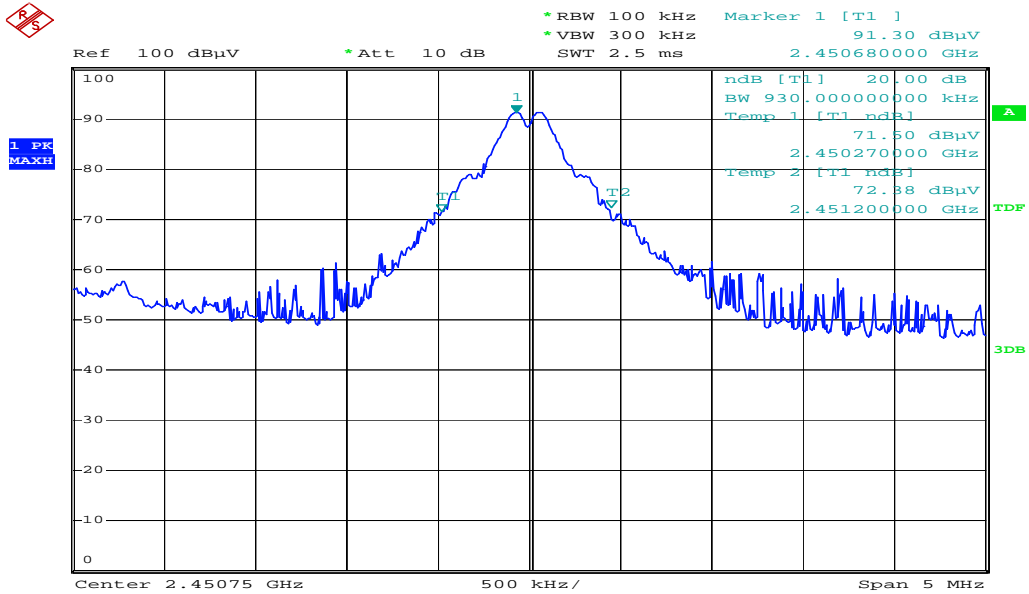

2475.75MHz 20dB Bandwidth

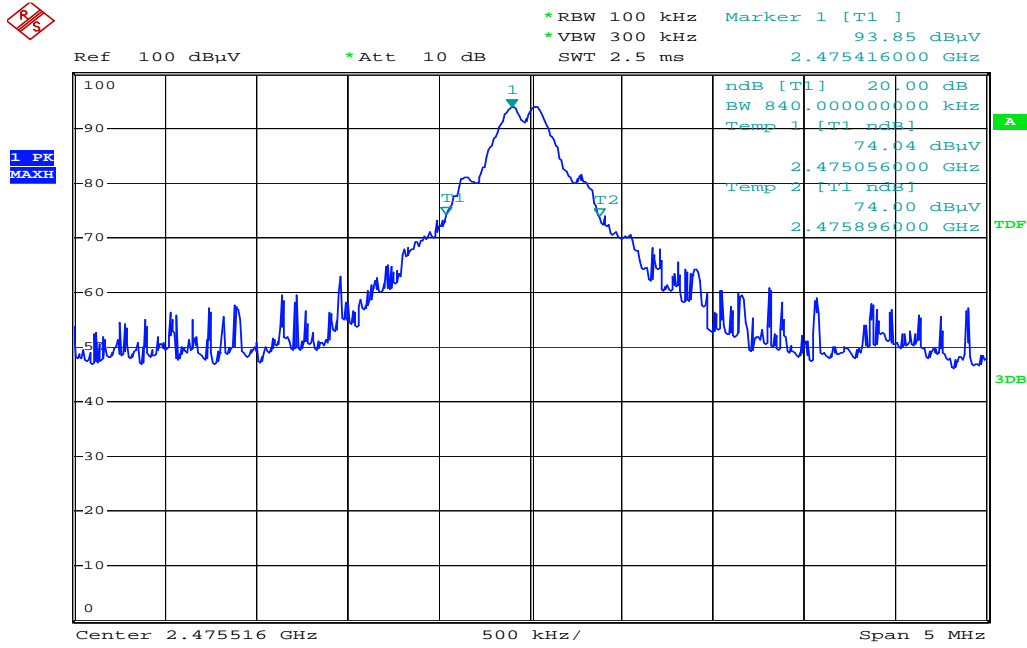

2425.75MHz Occupied Bandwidth



2450.75MHz Occupied Bandwidth

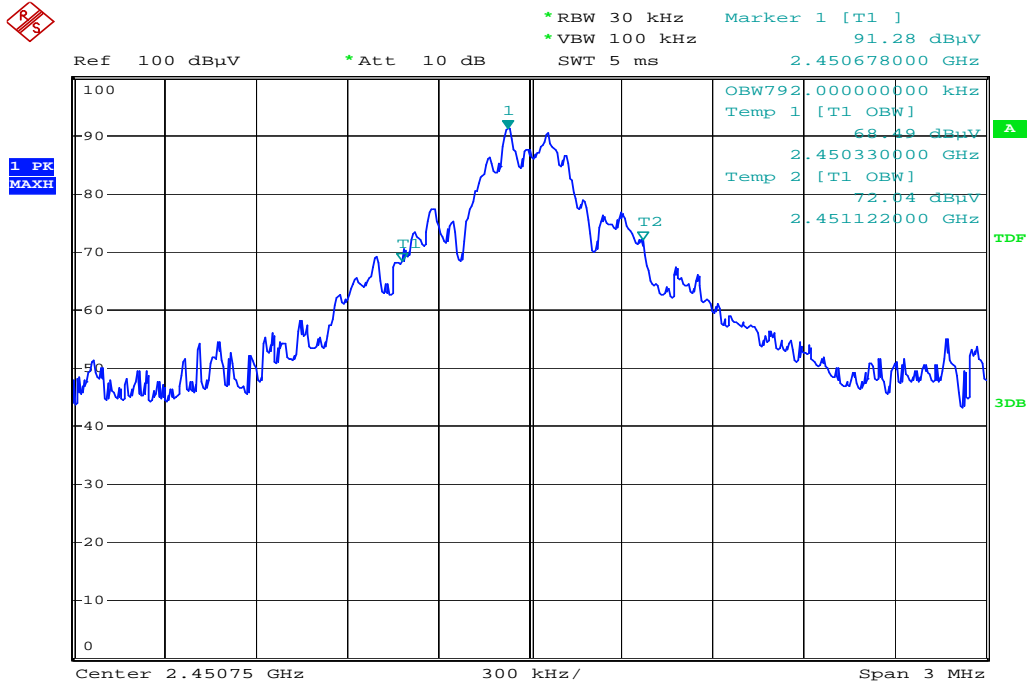

2475.75MHz Occupied Bandwidth

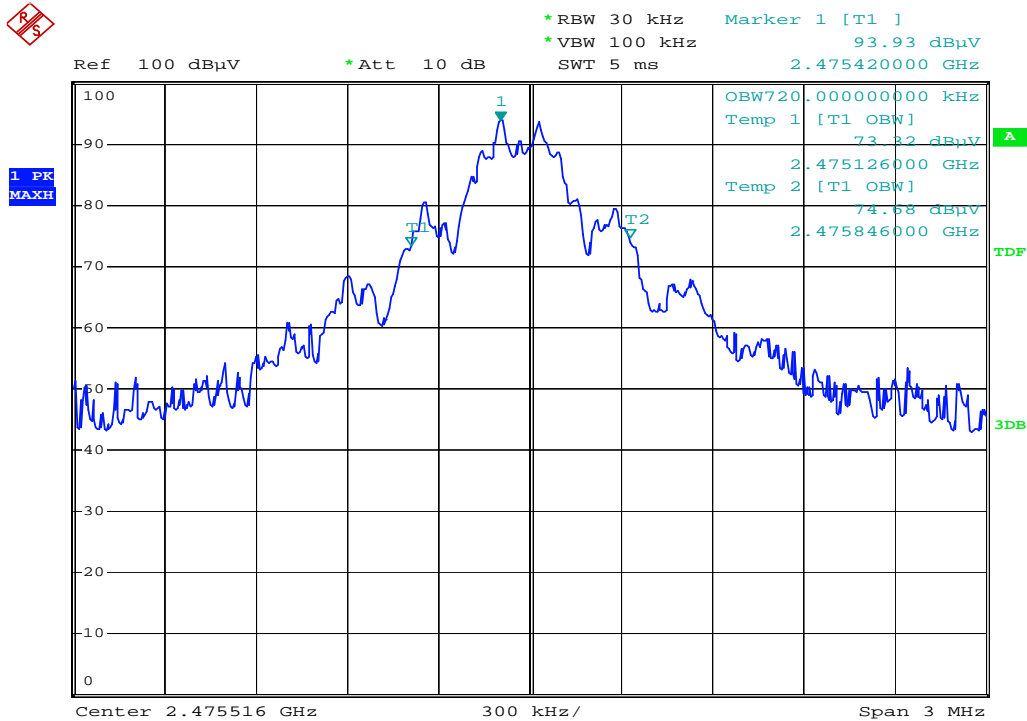

3 RF Radiated spurious emission test

3.1 Limit

According to FCC15.249 (a) & IC RSS-210 A2.9, the field strength of emissions from intentional radiators operated within these frequency bands shall comply with the following:

Fundamental frequency	Field strength of fundamental (millivolts/meter)	Field strength of harmonics (microvolts/meter)
902–928 MHz	50	500
2400–2483.5 MHz	50	500
5725–5875 MHz	50	500
24.0–24.25 GHz	250	2500

For intentional radiator, the radiated emission shall comply with §15.209(a).

Frequency (MHz)	Field strength dB(μ V/m)	Measurement distance (meters)
1.705~30.0	29.5	30
30 ~ 88	40	3
88~216	43.5	3
216~960	46	3
Above 960	54	3

3.2 Configuration of Measurement

Measurement Frequency under 1GHz

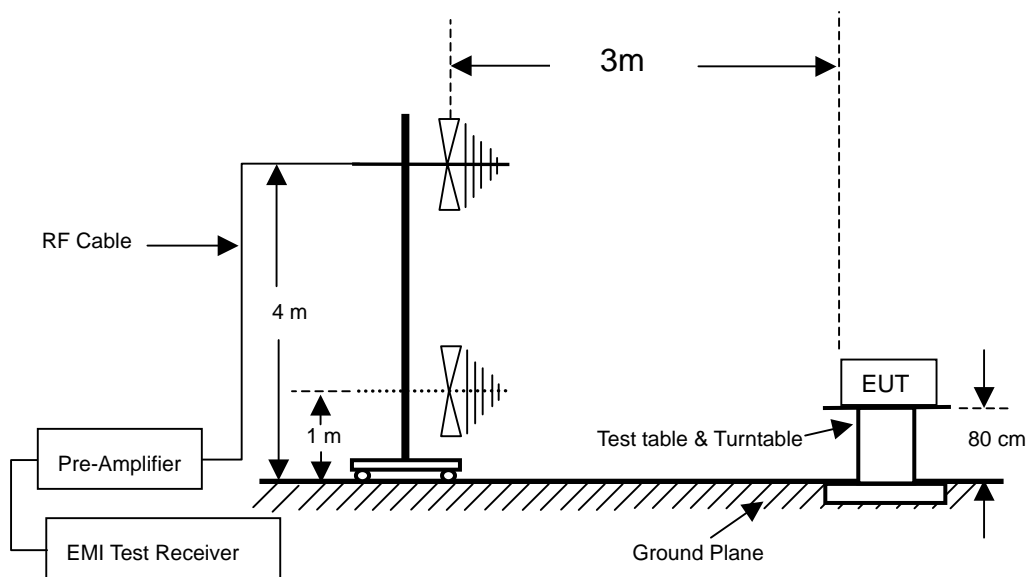

Measurement Frequency above 1GHz

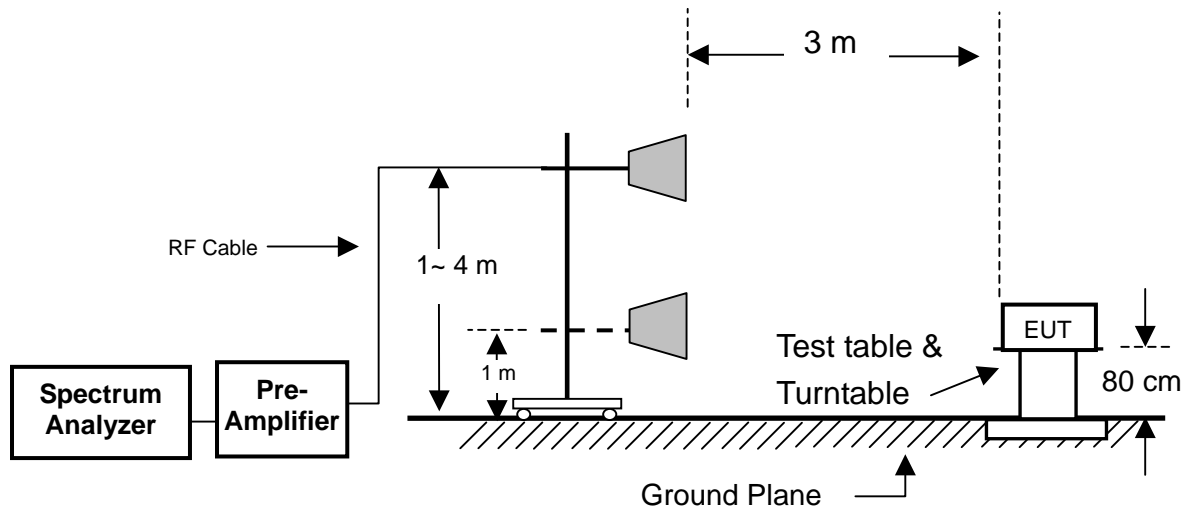

3.3 Test Procedure

The EUT was setup to ANSI C63.4, 2003.

Radiated emission measurements were performed from 30MHz to 25GHz. Spectrum Analyzer set as below: For frequency range from 30MHz to 1GHz: RBW=100kHz or greater. For frequencies above 1GHz: set RBW=VBW=1MHz for peak detector and RBW=1MHz, VBW=10Hz for average detector.

The EUT for testing is arranged on a wooden turntable. If some peripherals apply to the EUT, the peripherals will be connected to EUT and the whole system. During the test, all cables were arranged to produce worst-case emissions. The signal is maximized through rotation. The height of antenna and polarization is changing constantly for exploring for maximum signal level. The height of antenna can be up to 4 meter and down to 1 meter.

3.4 The description of operation mode

Setup EUT to continuously transmit signal with 100% duty cycle during the test period.

3.5 Test Result

PASS.

The final test data is shown on as following pages.

Radiated spurious emission

Fundamental Emissions

By preliminary testing and verifying three axis (X, Y and Z) position of EUT transmitted status, it was found that “X axis” position was the worst.

Low Channel								
Frequency	Antenna	Reading	Preamp	Correction Factor	Corrected Level	Limits	Margin	Det
(MHz)	Polarization	(dBuV)	(dB)	(dB/m)	(dBuV/m)	(dBuV/m)	(dB)	Mode
2425.75	H	58.76	0.00	31.52	90.28	94	-3.72	PK
2425.75	V	63.52	0.00	31.52	95.04	114	-18.96	PK
2425.75	V	40.20	0.00	31.52	71.72	94	-22.28	AV

Middle Channel								
Frequency	Antenna	Reading	Preamp	Correction Factor	Corrected Level	Limits	Margin	Det
(MHz)	Polarization	(dBuV)	(dB)	(dB/m)	(dBuV/m)	(dBuV/m)	(dB)	Mode
2450.75	H	58.33	0.00	31.60	89.93	94	-4.07	PK
2450.75	V	63.14	0.00	31.60	94.74	114	-19.26	PK
2450.75	V	39.68	0.00	31.60	71.28	94	-22.72	AV

High Channel								
Frequency	Antenna	Reading	Preamp	Correction Factor	Corrected Level	Limits	Margin	Det
(MHz)	Polarization	(dBuV)	(dB)	(dB/m)	(dBuV/m)	(dBuV/m)	(dB)	Mode
2475.75	H	56.98	0.00	31.68	88.66	94	-5.34	PK
2475.75	V	64.23	0.00	31.68	95.91	114	-18.09	PK
2475.75	V	44.78	0.00	31.68	76.46	94	-17.54	AV

Remark :

1. Corrected Level = Reading – Preamp + Correction Factor
2. Correction Factor = Antenna Factor + Cable Loss

Radiated spurious emission

Test Environment

Ambient temperature : 23.9°C

Relative humidity : 50%

Radiated Emission below 1GHz

After verifying low, middle and high channel (2425.75MHz, 2450.75MHz and 2475.75MHz), the worse case was found at High channel, the data will present on report.

Frequency	Antenna	Reading	Preamp	Correction Factor	Corrected Level	Limits	Margin	Det
(MHz)	Polarization	(dBuV)	(dB)	(dB/m)	(dBuV/m)	(dBuV/m)	(dB)	Mode
112.850	H	42.05	29.94	13.40	25.51	43.52	-18.01	QP
165.800	H	38.77	30.03	17.61	26.35	43.52	-17.17	QP
231.850	H	39.07	30.07	20.33	29.33	46.02	-16.69	QP
307.540	H	42.50	29.80	17.84	30.54	46.02	-15.48	QP
391.080	H	38.00	29.53	20.82	29.29	46.02	-16.73	QP
459.380	H	37.19	29.46	21.96	29.69	46.02	-16.33	QP
135.230	V	39.96	29.95	16.62	26.63	43.52	-16.89	QP
189.530	V	39.20	29.80	19.87	29.27	43.52	-14.25	QP
245.800	V	39.29	30.02	21.53	30.80	46.02	-15.22	QP
296.570	V	35.67	29.84	22.55	28.38	46.02	-17.64	QP
338.280	V	40.67	29.59	18.35	29.43	46.02	-16.59	QP
453.220	V	37.87	29.49	21.60	29.98	46.02	-16.04	QP

Remark:

$$\text{Corrected Level} = \text{Reading} + \text{Correction Factor} - \text{Preamp}$$

$$\text{Correction Factor} = \text{Antenna Factor} + \text{Cable Loss}$$

Radiated spurious emission

Radiated Emission above 1GHz

Low Channel								
Frequency	Antenna	Reading	Preamp	Correction Factor	Corrected Level	Limits	Margin	Det
(MHz)	Polarization	(dBuV)	(dB)	(dB/m)	(dBuV/m)	(dBuV/m)	(dB)	Mode
4851.50	H	43.54	27.44	37.77	53.87	74	-20.13	PK
4851.50	H	39.96	27.44	37.77	50.29	54	-3.71	AV
7277.25	H	33.56	26.90	44.51	51.17	54	-2.83	PK
*9703.00	H	30.98	26.33	47.92	52.57	54	-1.43	PK
4851.50	V	42.50	27.44	37.77	52.83	54	-1.17	PK
7277.25	V	32.68	26.90	44.51	50.29	54	-3.71	PK
*9703.00	V	31.08	26.33	47.92	52.67	54	-1.33	PK
Middle Channel								
Frequency	Antenna	Reading	Preamp	Correction Factor	Corrected Level	Limits	Margin	Det
(MHz)	Polarization	(dBuV)	(dB)	(dB/m)	(dBuV/m)	(dBuV/m)	(dB)	Mode
4901.50	H	43.93	27.46	37.90	54.37	74	-19.63	PK
4901.50	H	39.52	27.46	37.90	49.96	54	-4.04	AV
7352.25	H	34.00	26.91	44.90	51.99	54	-2.01	PK
*9803.00	H	30.80	26.32	48.23	52.71	54	-1.29	PK
4901.50	V	44.45	27.46	37.90	54.89	74	-19.11	PK
4901.50	V	40.37	27.46	37.90	50.81	54	-3.19	AV
7352.25	V	33.83	26.91	44.90	51.82	54	-2.18	PK
*9803.00	V	30.98	26.32	48.23	52.89	54	-1.11	PK
High Channel								
Frequency	Antenna	Reading	Preamp	Correction Factor	Corrected Level	Limits	Margin	Det
(MHz)	Polarization	(dBuV)	(dB)	(dB/m)	(dBuV/m)	(dBuV/m)	(dB)	Mode
4951.50	H	44.40	27.48	38.03	54.95	74	-19.05	PK
4951.50	H	40.00	27.48	38.03	50.55	54	-3.45	AV
7427.25	H	33.60	26.92	45.30	51.98	54	-2.02	PK
*9903.00	H	30.68	26.31	48.54	52.91	54	-1.09	PK
4951.50	V	44.83	27.48	38.03	55.38	74	-18.62	PK
4951.50	V	41.14	27.48	38.03	51.69	54	-2.31	AV
7427.25	V	33.81	26.92	45.30	52.19	54	-1.81	PK
*9903.00	V	30.74	26.31	48.54	52.97	54	-1.03	PK

Remark : Corrected Level = Reading + Correction Factor – Preamp

Correction Factor = Antenna Factor + Cable Loss

* Mark indicated background noise level.

Receiver spurious emission

Receiver spurious Emission below 1GHz								
Frequency	Antenna	Reading	Preamp	Correction Factor	Corrected Level	Limits	Margin	Det
(MHz)	Polarization	(dBUV)	(dB)	(dB/m)	(dBUV/m)	(dBUV/m)	(dB)	Mode
156.350	H	38.59	30.20	17.20	25.59	43.52	-17.93	QP
185.720	H	36.10	29.76	19.01	25.35	43.52	-18.17	QP
268.200	H	35.73	30.07	21.88	27.54	46.02	-18.48	QP
348.490	H	40.10	29.42	18.72	29.40	46.02	-16.62	QP
402.200	H	36.55	29.56	21.05	28.04	46.02	-17.98	QP
452.090	H	37.02	29.49	21.77	29.30	46.02	-16.72	QP
132.870	V	39.06	29.93	16.44	25.57	43.52	-17.95	QP
169.700	V	36.20	29.91	18.71	25.00	43.52	-18.52	QP
224.700	V	38.67	30.10	20.92	29.49	46.02	-16.53	QP
283.400	V	36.60	30.00	22.52	29.12	46.02	-16.90	QP
358.290	V	40.20	29.40	18.89	29.69	46.02	-16.33	QP
414.730	V	38.500	29.31	20.86	30.05	46.02	-15.97	QP

Remark:

Corrected Level = Reading + Correction Factor – Preamp

Correction Factor = Antenna Factor + Cable Loss

Receiver spurious Emission above 1GHz								
Frequency	Antenna	Reading	Preamp	Correction Factor	Corrected Level	Limits	Margin	Det
(MHz)	Polarization	(dBUV)	(dB)	(dB/m)	(dBUV/m)	(dBUV/m)	(dB)	Mode
2457.00	H	37.26	27.83	31.62	41.05	54.00	-12.95	PK
*4950.00	H	34.26	27.48	38.03	44.81	54.00	-9.19	PK
2457.00	V	38.96	27.83	31.62	42.75	54.00	-11.25	PK
*4950.00	V	34.85	27.48	38.03	45.40	54.00	-8.60	PK

Remark : Corrected Level = Reading + Correction Factor – Preamp

Correction Factor = Antenna Factor + Cable Loss

* Mark indicated background noise level.

4 Emission on the Band Edge test

4.1 Limit

Emissions radiated outside of the specified frequency bands, except for harmonics, shall be attenuated by at least 50 dB below the level of the fundamental or to the general radiated emission limits in FCC 15.209 & IC RSS-210 A2.9, whichever is the lesser attenuation.

4.2 Configuration of Measurement

Measurement Frequency above 1GHz

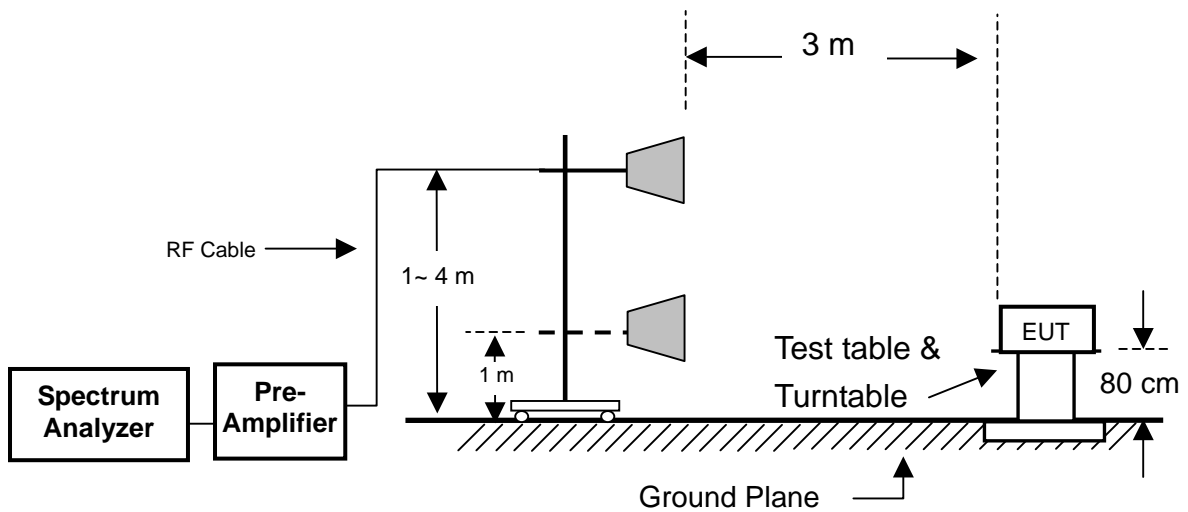

4.3 Test Procedure

The EUT was setup to ANSI C63.4, 2003.

Set RBW =1M, VBW= RBW for peak, and VBW=10Hz for average.

The EUT for testing is arranged on a wooden turntable. If some peripherals apply to the EUT, the peripherals will be connected to EUT and the whole system. During the test, all cables were arranged to produce worst-case emissions. The signal is maximized through rotation.

The height of antenna and polarization is changing constantly for exploring for maximum signal level. The height of antenna can be up to 4 meter and down to 1 meter.

4.4 Test Result

PASS.

The final test data is shown on as following pages.

Band edge

Frequency (MHz)	Restrict Freq. Band (MHz)	Maximum level (dBuV/m)	Limit (dBuV/m)	Magin (dB)	Det Mode
2425.75	2310~2400	55.07	74	-18.93	PK
2425.75	2310~2400	41.30	54	-12.7	AV
2475.75	2483.5~2500	64.66	74	-9.34	PK
2475.75	2483.5~2500	41.89	54	-12.11	AV

2425.75MHz-AV

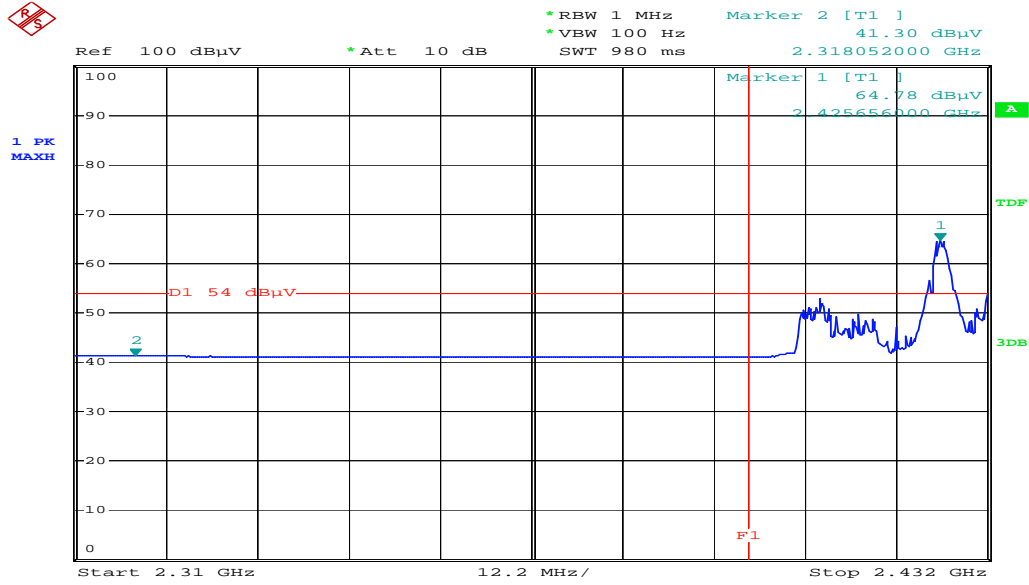

2425.75MHz-PK

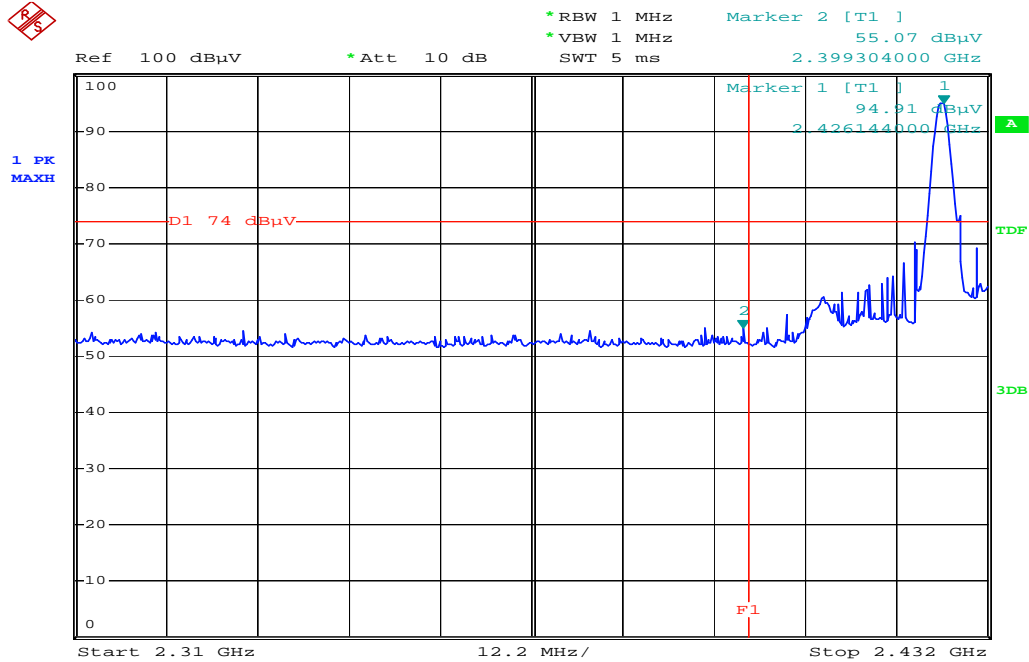

2475.75MHz-AV

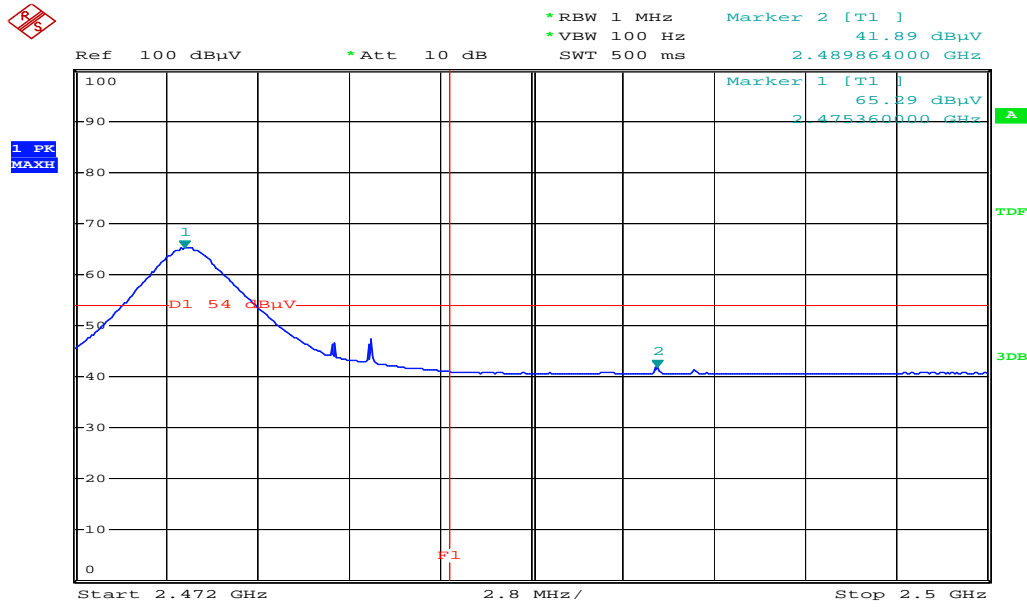

2475.75MHz-PK

