



**CONVOY
TECHNOLOGIES**

USER MANUAL

Wireless Video Camera MODEL:C7010



Please read this manual thoroughly before operating the unit, and keep it for further reference.



**CONVOY
TECHNOLOGIES**

Table of Contents

1. PRODUCT/SERVICE DESCRIPTION	2
1.1 PRODUCT CONTEXT	3
1.2 USER CHARACTERISTICS	3
2.3 OPERATION	3
2. PRECAUTIONS	3,4
3. SYSTEM AND COMPONENTS	4
3.1 WIRELESS RF TRANSMITTER	4,5,6,7
3.2 CAMERA	8
3.3 IR BOARD	9
3.4 RECEIVER/MONITOR	9,10
3.5 BATTERY & POWER MANAGEMENT BOARD	10
3.6 ENCLOSURE	10,11
3.7 MAGNET	11
3.8 ANTENNA	12
3.9 LED	12,13
3.10 POWER BUTTON	13
3.11 PAIRING BUTTON	13
3.12 DC CHARGING JACK	14
3.13 CHARGER	14,15
4. USER INTERFACE REQUIREMENTS	15
4.1. USABILITY	15
4.2. PERFORMANCE	15
4.2. AVAILABILITY	15
5. COMPLIANCE WITH STANDARDS	15
6. WARRANTEE	15



**CONVOY
TECHNOLOGIES**

1. Product/Service Description

1.1 Product Context

A battery powered wireless camera product that is specifically designed for tractor trailer vehicles and/or unmarried vehicles on the road. This camera system will provide a removable (magnetic) camera and monitoring solution to better assist drivers overcome the blind spots around their tractors and trailers.

1.2. User Characteristics

Tractor Trailers are among the largest vehicles on the road. Because of their size and the amount of deliveries they make, they are often times found required to maneuver in very tight spaces at the delivery destinations, along our highways or parking structures. Currently, because the tractor and trailer are not permanently connected to each other, there is no way to run cables to and from the cab of the tractor back to the trailer, especially since the tractor usually operates different trailers. This solution is using wireless RF technology and a combination of specially designed magnetics, cameras, and rechargeable batteries. Most trailers (93%+) do not have power being sent from the tractor to the trailer. A battery powered wireless solution addresses this need in the automotive industry. **Solution:** This wireless camera system can be attached to any trailer, in a nonpermanent manner, using magnets and batteries enclosed in a single housing where the camera is located. Today, while the driver is backing into a loading dock or driving in a “populated” parking lot/structure, he is often required to have a spotter and turn on his flashers and use his mirrors. This magnetic, rechargeable, wireless camera can now be attached to any part of the trailer and provide immediate infrared, night vision, video to the cab through an existing or one of our proprietary monitors. The camera will NOT “crosstalk” with any other cameras as it is individually paired with a monitor/receiver at any given time. Following product generations will add a solar panel and permanently mounted camera, recharged using photovoltaic cells.

1.3.Operation

This wireless backup camera system is designed to be used temporarily for difficult tractor/trailer maneuvers; it is NOT A PERMANENT SYSTEM FOR DRIVING ON THE ROAD.

WARNING: The driver must insure that the unit is removed from the back of the trailer before continuing driving.

The monitor unit has a secondary Red LED indication that pairing was interrupted.

2. Precautions

● Storage and keeping

1. Do not expose the monitor to excessive heat or cold. The storage temperature of this device is -20 ~+65°C, and the operating temperature is -10 ~+65°C. The Humidity is Rh90%.
2. Never use this device near a bathtub, wash basin, kitchen, damp basement, swimming pool or similar place.
3. Never use this device in environments with excessive moisture, dust or smoke.



**CONVOY
TECHNOLOGIES**

4. Avoid dropping or striking this device.
5. Avoid using this device in enclosed spaces, areas with excessive vibration or subject to severe impacts.
6. Never puncture, scratch or use abrasive cleaning materials on this device.
7. Do not place cables where they may be pinched or stepped on.
8. Leave at least a 2" space between the unit and walls, or other objects to allow adequate air circulation around the unit.
9. The wireless camera must be removed and stored back in the driver cabin before continuing driving.

● **Operating Precautions**

1. The device has a Lithium Ion battery. Charging can be powered by a 12 volt automotive battery or vehicle electrical system.
2. For monitor/Receiver and Charger, make sure all cables are connected properly observe polarity. Improper cable connections may damage the system. Remove the power cable connections when you do not intend to use the unit.

3. System and components. Diagram and Technical Specifications.

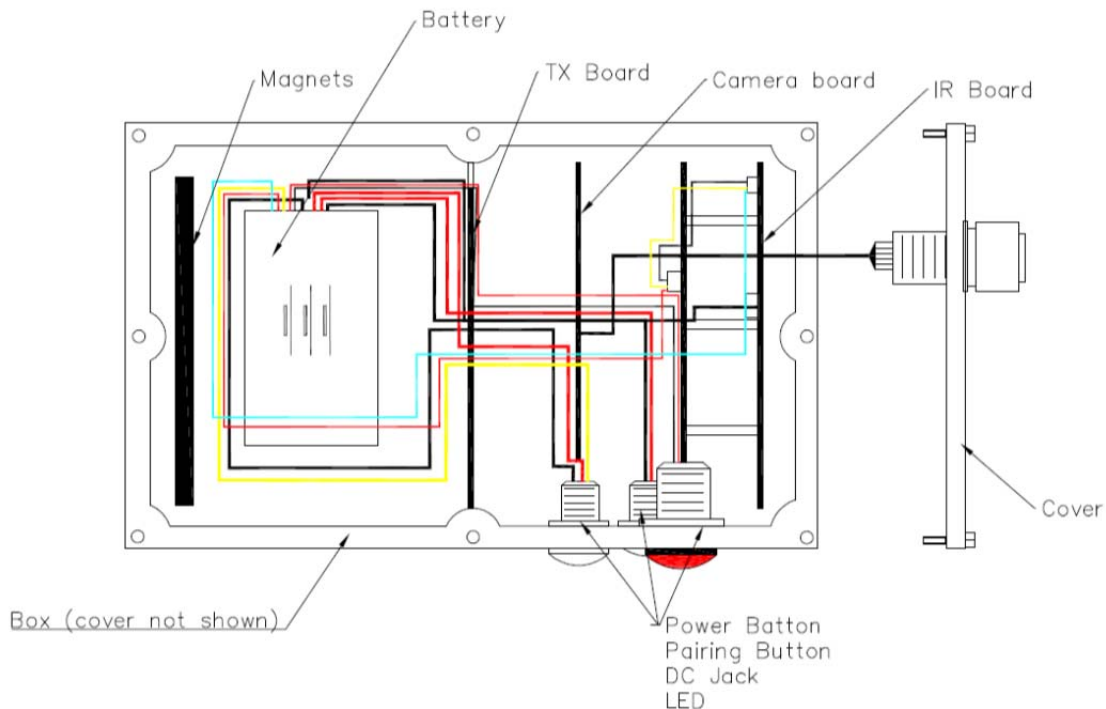

3.1. Wireless RF Transmitter



**CONVOY
TECHNOLOGIES**

RF 2.4GHz technology(POWER SUPPLY)	+5~+12V
TX (Current Consumption)	TYPE:330mA, Max.400mA
RX(Current Consumption)	200mA
Environmental Specification)	
Operating Temperature)	-10~+60 °C
Storing Temperature)	-30~+85 °C
Operating humidity)	85%RH
BASEBANGD SPEC.)	
POWER ON)	2SEC Max. RE
	TBD Max. SE/AV
Latency)	100ms Max. RE
	TBD Max. SE/AV
Resolution)	VGA/640X480 RE
	PAL:720X576/NTSC:720X480 SE/AV
Frame Rate)	30f/s
	NTSC:30f/s/PAL: 25f/s SE/AV
Video Codec	MPEG4
TX (Video in System)	PAL/NTSC Auto detection
RX (Video out System)	PAL/NTSC Auto detection
Audio Codec)	MP3 1Channel
(Voice Sample Rate)	8KHz M RE/SE
	48KHz AV
(Voice Frequecny Band)	340Hz~3.4KHz RE/SE
	20Hz~20KHz AV
(ID) / (BIT)	Pairing) /22(4KK)
(SYSTEM Architecture)	ARM9(32Bit) SOC
(RF SPEC.)	
(Operation Frequency)	2400 ~ 2483.5MHz*



CONVOY
TECHNOLOGIES

(RF Impedance)	50Ω, Typ.

Richwave 6758 standard specification .

Features

Multi-format MPEG encoder (*MPEG Encoder format specification*)

- MPEG4 encoder
30 fps at 720x480, 25 fps at 720x576
- H.263 encoder:
- JPEG encoder
- Video pre-processing

Multi-format MPEG decoder (*MPEG Decoder format specification*)

- 30 fps at 720x480, 25 fps at 720x576
- H.263 decoder:
- JPEG decoder
- Video post-processing

Video capture input and LCD output interface (*Video/Audio Signal Input & Output Interface*)

- Video Capture interface
CCIR656 for external TV decoder
Raw RGB for CMOS/CCD sensor
- LCD Output interface
CCIR656 for LCD panel
8 bits series RGB of LCD panel

TV out (*Video out supporting CVBS Format which is what we are using*)

High speed serial programming interface (SPI) for companion RF chip. (*SPI is interface use for connecting their RF sub-module*)

I2C for companion CMOS sensor device control. (*only applied for Embedded CMOS, not apply for our PCB Design*)

UARTs for debugging. (*UARTs is only for programming/debugging use*)

Power Management Control (*Build-in PM module to handle energy saving control*)

Package: 196-ball LFBGA 14mm*14mm (*196-ball BGA is what 6758 use*)

Product Features

Product Overview 6758 chip (Richwave)

The RTC6758 is a highly integrated SOC (System On Chip) platform with a high-speed 32-bit ARM926 CPU core for embedded applications and a powerful hardwired multi-format MPEG encoder/decoder for video acceleration as well as a variety of interfaces which are suitable for digital audio / video application. It contains NOR flash controller,



**CONVOY
TECHNOLOGIES**

SDRAM controller, USB OTG controller, DMA controller and smart power saving mechanism to be a very powerful SOC platform. Some interfaces like video capture, LCD controller, TV encoder with 1-channel DA, audio AD/DA with digital filters, I2S, SPI are very suitable for audio / video applications.

Product Overview 6763 chip (Richwave)

RTC6763 is a 2.4GHz ISM band HDR (high data rate) FH (frequency hopping) transceiver. The device is a single chip solution with integrated MAC, BBP and RF for wireless application operating in 2.4GHz band. It provides three types of digital modulation 16QAM/QPSK/BPSK, and on-air data rate support 12Mbps/6Mbps/3Mbps. It provide 80 overlay channels, and each channel can be independently enable or disable with hopping table. Just enabling one channel with hopping table setting RTC6763 can operate at fixed frequency, or enabling several channels with hopping table setting RTC6763 can operate as FH transceiver to reduce co-channel interference. Using smart interference detection algorithm hopping table can be updated by SPI digital interface, and this feature allows RTC6763 to avoid other interferences in 2.4 GHz band. RTC6763 with TDD (Time Division Duplex) functionality creates a centralized network with one master to coordinate up to four slaves. The system can operate in single mode (1 master with 1 slave) or multiple display mode (1 master with up to 4 slaves). Mode switching can be performed on the fly. It is available in a 40-pin QFN 6mmX6mm package and RoHS certificate.

- Wireless TX board connections:
 - Video, audio, +/- to camera
 - 3 wire to pairing button
 - +/- to IR board

The latest TX board updates:

- a. Move the 12V to 5V DC to DC regulation to separate power board.
- b. Change the TX board to 5VDC input.
- c. Re-layout the board for more efficient thermal transfer from the chip to PCB
- d. Re-layout the board for more efficient thermal conduction between the PCBA and enclosure.
- e. Change L10 from BEAD to 27R to solve the image drop problem
- f. Change R10 from 4.7K to 10K to improve startup stability
- g. Add resistor to change the CPU to run at 120MHz clock. (20mA@5VDC current reduction)
- h. Add 3 more resistors to reserve performance tuning capability with system clock adjustment.
- i. Change bootloader firmware to shut down unnecessary on-chip circuitry.



CONVOY
TECHNOLOGIES

3.2. Camera:

Sensor: 1/3" Sony HAD color camera
Resolution (pixel): 967x494
Lens: f=2.8mm
Lens angle: 90° Horizontal; 65° Vertical
Mini-Illumination: 0Lux (LED ON)
IR LED: 12 pcs
IR switch: available
Night Vision Distance: 36ft.
Video format: NTSC
Audio: available
2.4GHz RF Technology
Transmitting Distance: min. 90' barrier free
Voltage: 12V
Battery: 3s2p 18650 Lithium Ion rechargeable
Operating temperature: 0 to 65C
Timer: 15 minutes time off, can be re-started by pressing the power button
LED Red: Low battery indicator (Need to charge the battery)
LED Green: Battery charged
Pairing indicator (flashes when paired, constant green light when successfully paired)
DC Port for charger
Magnets on the back and bottom of Magcam for removable mounting
Waterproof: IP65
Enclosure material: Aluminum Alloy
Dustproof, waterproof, protection against hydrochloric acid
Dimensions: 97(W)x82(H)x140(L)mm
MAGCAM is a wireless backup camera system designed for temporary use during difficult tractor/trailer maneuvers; it is NOT A PERMANENT SYSTEM FOR DRIVING ON THE ROAD.



**CONVOY
TECHNOLOGIES**

3.3. IR board

Microphone (12V, 500uA)

IR board : (12V, 80mA)

Camera board, IR Board use in C1800AHD

- | | |
|--|----------------------|
| 1) Input Voltage Range: Vmin, Vnom, Vmax | Spec : 1)9V, 10V,11V |
| 2) Input Current Range: Imin, Imax, Imax | 2)10mA ,120mA |
| 3) Operating Temperature Range | 3)-20°C~+70 °C |
| 4) Storage Temperature Range | 4)-30 °C ~+75 °C |

5) Light Sensitivity (Resistant 30~50KΩ)

6) Microphone Sensitivity (-58 ~ -54dB)

3.4 Receiver/Monitor

2.4GHz Technology

7" Monitor with Digital Panel

Resolution: 800*R.G.B*480

Power voltage: DC 12V-24V

Pairing indicator (flashes when paired, constant green light when successfully paired)

LED Red flashing LED: Warning for lost connection between Magcam and receiver

Operating frequency: 2400-2483.5 MHz

Decompression form: MPEG 4

Emitting frequency: 2403-2478MHz

Transmitting speed: 12 Mbps

Receiving Sensitivity: -78dBm@1MHZ 16QAM VR850/AV

Spread spectrum: frequency hopping

Hopping rate: 1200/S

Outer dimension: 182(L) X 75(W) X 124(H) mm

Brightness: 400cd/m².

Viewing angle: U: 50°/ D: 60°, R/L: 70°

Operating temperature: -10°C~+65°C

Storage temperature: -30°C to + 80°C RH90%



**CONVOY
TECHNOLOGIES**

CT-M7102 Monitor

- | | |
|--|------------------------|
| 1) Input Voltage Range: Vmin, Vnom, Vmax | Spec : 1) 11V,15V, 24V |
| 2) Input Current Range: Imin, Imax, Imax | 2) 110mA ,300mA |
| 3) Operating Temperature Range | 3) -20°C~+70 °C |
| 4) Storage Temperature Range | 4) -30°C~+75 °C |

LCD Monitor Brightness (min to max) (400 CD/M2)

Speaker Output Level (82dB)

3.5. Battery: Lithium Ion 3s2p 18650, 10.8V, 5.8Ah; using Panasonic 18650 cells with 2.9Ah or 2450mAh capacity. Minimum 4 hours of battery life.

Unique safety and power management board that includes the following functionality:

- a. Lithium Ion safety protection against over charge, over discharge, over current and short circuit.
- b. Protection against charging outside allowable temperature range: 0C to 45C
- c. Low voltage indicator at 9.6V—Red LED
- d. Charged indicator at 12.55V—Green LED
- e. Voltage cut off at 9V to avoid deep discharge
- f. Time off for discharge cycles, set at 15 minutes (adjustable)

Dimensions: 70mm x 56mm x 38mm

Connector to battery input/DC jack: CT-HC2pM JST B2B-ZR-PCB 2 pin male wire connector

Connector to LED: CT-HC3pM JST B3B-ZR-PCB 3pin male wire connector

Connector to Power Button: CT-HC4pM B4B-ZR-PCB 4 pin male wire connector

Connector to battery output/IR board:CT-HC2pF ZHR-2 female wire connector

3.6. Water-resistant IP65 enclosure

Top cover is removable. Will use sealing material between Al/alloy surfaces.

Alloy material composition is:

		%
Ai	Aluminium	88.24
Si	Silicon	10.9



**CONVOY
TECHNOLOGIES**

Fe	Iron	0.676
Cu	Copper	1.13
Mn	Manganese	0.103
Mg	Magnesium	0.203
Cr	Chromium	0.553
Ni	Nickel	0.247
Zn	Zinc	0.614
Sn	Stannum	0.429
Ti	Titanium	0.0098
Pb	Plumbum	0.391

Note: No warranty after end user removes the top

3.7. Magnets

2 magnetic surfaces with recessed areas in the enclosure material or fixed with brackets to accommodate the magnets (approx. 5mm deep) on the following sides of the rectangular prism:

- bottom (90 deg from the side that includes the camera)
- back (parallel with the camera side)
- P/N# F50*25*10
- Dimensions 50 x 25 x 10mm w/holes
- Tolerances 0.05mm
- Material NdFeB, Grade N42
- Plating/Coating Zinc
- Max Operating Temperature: 80°C
- Brmax 14200 Gauss
- Bhmax 53.5 MGOe
- Intrinsic Coercive force (iHc) 12000 Oe
- Center Field 4300 Gs
- Thickness 7.4 - 7.5g/m³
- Thickness 7.4 - 7.5g/m³
- Magnetization: Direction Thru Thickness
- Pull Force, Case 1 70 lbs



**CONVOY
TECHNOLOGIES**

3.8. Wireless Antenna and connector:

P/N#: YL2400-MMCXJW-10CM-M12-46

Frequency range: 2400-2500MHz

Band width: 100MHz

V_{swr} ≤ 2.0

Gain: 2dBi

Impedance: 50ohm

Polarization: Vertical

Max. Power: 40W

ABS, dimensions: 46mm diameter, 16mm in height

Cable: RG316—100mm

Temperature range: -45C to 85C

Connector: MMCXJW

3.9. LED indicator light

P/N#8082.903 waterproof

Technical Parameters

Rate Current: 20mA

Rate Voltage: 2~200VAC/DC

Insulation resistance: 100Mohm (minimal)

Dielectric Strength: 1,000V RMS (minimal)

Humidity: under 85%

Withstand Voltage: ≥ 1000V 50/60Hz Last for 1 min

Vibration: 10 to 55Hz 1.5 double-amplitude

Dimensions: 8mm diameter

Color: Green and Red

Green & Red common anode



CONVOY
TECHNOLOGIES

Technical requirement

1. For parts there is no tolerance marked, please refer to GB/T1804-m Standard.
2. Product assembling should be smooth without stuck.
3. Rated Current: 20ml
Rated Voltage: 2-25VAC/DC
Insulation resistance: 100M ohm.

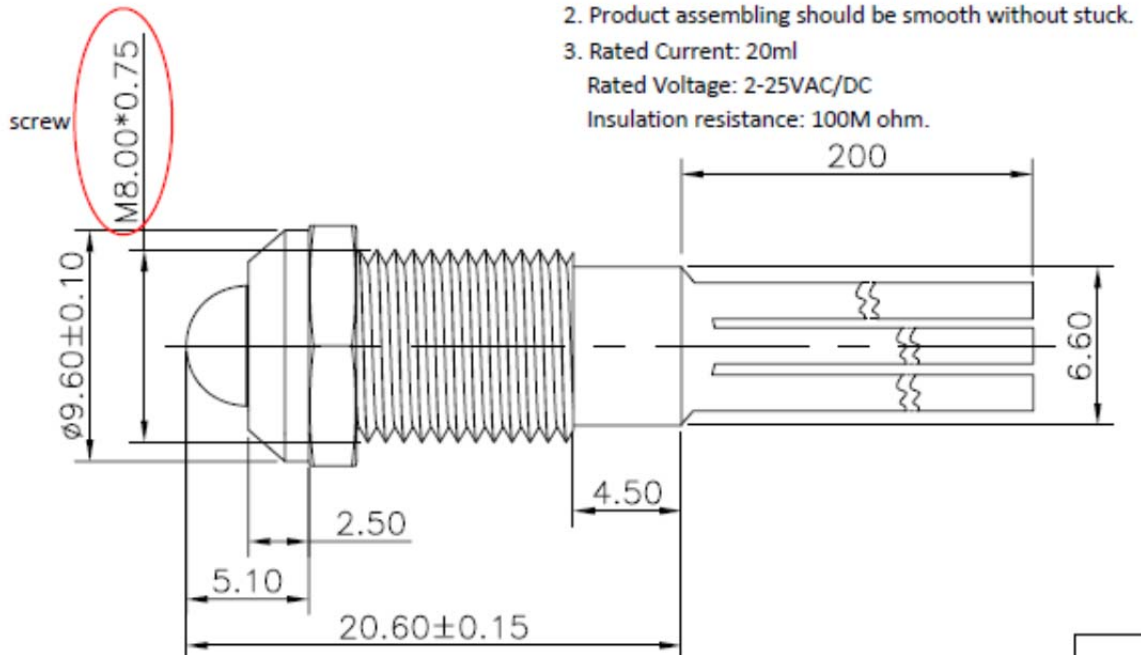

3.10. Waterproof power button: P/N# 4126.8132.35
3 wire connection to battery

3.11. Waterproof Pairing button P/N#: 4126.8221.18



- rubber insulator between enclosure and button
- 3 wire connection to wireless TX board

3.12. Waterproof DC charging connector, P/N#FKX6012P



**CONVOY
TECHNOLOGIES**

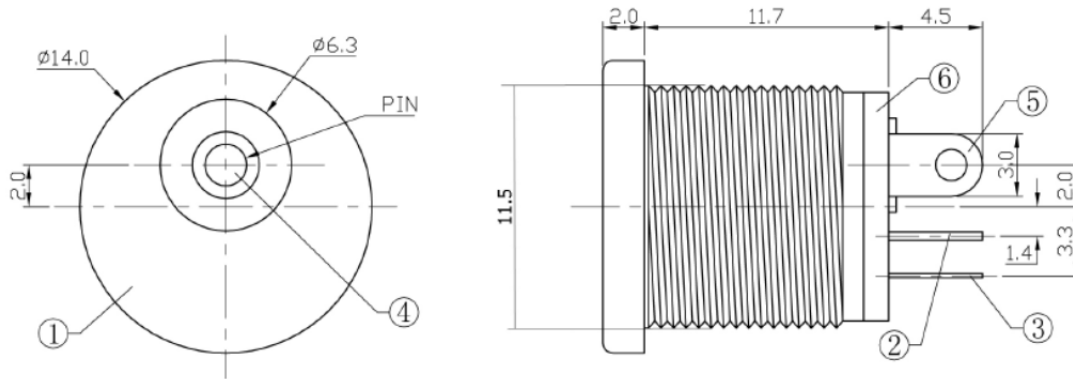

- Dimensions:

14mm round exterior

12mm round threaded

18.2mm depth into enclosure including power connector

- Rubber insulator between enclosure and connector
- Rubber plug for DC port

3.13. Charger, P/N# HYXF-12610A

Constant voltage charger

DC Input Voltage: DC12~24V

Idle current $\leq 30\text{mA}$, Input Voltage range at DC12-24V; Loading 1000mA, Output

Voltage 12.6V

DC Input Current (Input Current range at DC12V-24V) , Idle current $\geq 15\text{mA}$. Normal

operation input current $\leq 0.40\text{A}$

Efficiency of In-Vehicle use.

Charging efficiency $\geq 70\%$ (Input DC12-24V, Output Current 1000mA, Output

Voltage $\geq 12.0\text{V}$.)



**CONVOY
TECHNOLOGIES**

4. User Interface Requirements

4.1. Usability

MAGCAM is extremely easy-to-use, however Convoy Technologies will provide

- User documentation
- Driver training

4.2. Performance

- Wireless transmission over 90 ft.
- Clear camera image on receiver monitor

4.3. Availability

- Operation: 15 minutes per cycle

5. Standards Compliance

FCC
IP65

6. Warrantee

Warranty period will be valid of one year after shipping.

In case of defects, please contact the manufacturer, distributor or retailer.

For repair and maintenance, please include the following documents with the product:

- A copy of the receipt with purchasing date
- A reason for the claim or description of the fault

7. FCC Caution.

(1)§ 15.19 Labelling requirements.

This device complies with part 15 of the FCC Rules. Operation is subject to the following two conditions: (1) This device may not cause harmful interference, and (2) this device must accept any interference received, including interference that may cause undesired operation.

§ 15.21 Changes or modification warning

Any Changes or modifications not expressly approved by the party responsible for compliance could void the user's authority to operate the equipment.

§ 15.105 Information to the user.

Note: This equipment has been tested and found to comply with the limits for a Class B digital device, pursuant to part 15 of the FCC Rules. These limits are designed to provide reasonable protection against harmful interference in a residential installation. This equipment generates uses and can radiate radio frequency energy and, if not installed and used in accordance with the instructions, may cause harmful interference to radio communications.

However, there is no guarantee that interference will not occur in a particular installation. If this equipment does cause harmful interference to radio or television reception, which can be determined by turning the equipment off and on, the user is encouraged to try to correct the interference by one or more of the following measures:

- Reorient or relocate the receiving antenna.
- Increase the separation between the equipment and receiver.
- Connect the equipment into an outlet on a circuit different from that to which the receiver is connected.
- Consult the dealer or an experienced radio/TV technician for help.