

Peloton Interactive Inc.

TEST REPORT

REPORT NUMBER
180300424TWN-001

ISSUE DATE

Jul. 12, 2018

PAGES
34

DOCUMENT CONTROL NUMBER

© 2018 INTERTEK



Radio Spectrum TEST REPORT

Applicant:	Peloton Interactive Inc. 125 W 25th St, 11th Floor, New York, NY 10001
Product:	Peloton Tread Tablet
Model No.:	PLTN-TC1VS
Brand Name:	Peloton Console
FCC ID:	2AA3N-TC1VS
Test Method/ Standard:	47 CFR FCC Part 15.225
Test By:	Intertek Testing Services Taiwan Ltd., Hsinchu Laboratory No. 11, Lane 275, Ko-Nan 1 Street, Chia-Tung Li, Shiang-Shan District, Hsinchu City, Taiwan



Prepared and Checked by:

Approved by:

*Durant Wei**Maxy You*

Durant Wei
Engineer

Maxy You
Engineer

This report is for the exclusive use of Intertek's Client and is provided pursuant to the agreement between Intertek and its Client. Intertek's responsibility and liability are limited to the terms and conditions of the agreement. Intertek assumes no liability to any party, other than to the Client in accordance with the agreement, for any loss, expense or damage occasioned by the use of this report. Only the Client is authorized to permit copying or distribution of this report and then only in its entirety. Any use of the Intertek name or one of its marks for the sale or advertisement of the tested material, product or service must first be approved in writing by Intertek. The observations and test results in this report are relevant only to the sample tested. This report by itself does not imply that the material, product, or service is or has ever been under an Intertek certification program.

Revision History

Report No.	Issue Date	Revision Summary
180300424TWN-001	Jul. 12, 2018	Original report

Table of Contents

Summary of Test Data	5
1. General Information	6
1.1 Identification of the EUT	6
1.2 Antenna description	6
1.3 Peripherals equipment	6
1.4 Operation mode	6
2. Fundamental emission	7
2.1 Operating environment	7
2.2 Limit for Fundamental emission.....	7
2.3 Measuring instrument setting.....	7
2.4 Test procedure	8
2.5 Test diagram	8
2.6 Test result	9
3. 20 dB Bandwidth	10
3.1 Operating environment	10
3.2 Limit for 20 dB bandwidth.....	10
3.3 Measuring instrument setting.....	10
3.4 Test procedure	10
3.5 Test results.....	11
4. Frequency Satiability	12
4.1 Operating environment	12
4.2 Limit for Frequency Satiability.....	12
4.3 Measuring instrument setting.....	12
4.4 Test procedure	12
4.5 Test result	13
5. In band Radiated Emissions.....	18
5.1 Operating environment	18
5.2 Limit for emissions in non-restricted frequency bands.....	18
5.3 Measuring instruments setting	18
5.4 Test procedure	19
5.5 Test diagram	19
5.6 Test results.....	20
6. Out of band Radiated Emissions.....	21
6.1 Operating environment	21
6.2 Limit for emission in restricted frequency bands (Radiated emission measurement) ..	21
6.3 Measuring instrument setting.....	22
6.4 Test procedure	22
6.5 Test configuration	23
6.5.1 Radiated emission from 9kHz to 30MHz uses Loop Antenna:	23

TEST REPORT

- 6.5.2 Radiated emission below 1GHz using Bilog Antenna..... 23
- 6.6 Test result 24
- 6.6.1 Measurement results: frequency range from 9 kHz to 30 MHz..... 24
- 6.6.2 Measurement results: frequencies below 1 GHz 26
- 7. AC Power Line Conducted Emission 28
- 7.1 Measuring instrument setting..... 28
- 7.2 Test Procedure 28
- 7.3 Test Diagram 28
- 7.4 Limit..... 29
- 7.5 Operating Environment Condition 29
- 7.6 Test Results 30

- Appendix A: Test equipment list..... 32

- Appendix B: Measurement Uncertainty..... 34

Summary of Test Data

Test Requirement	Applicable Rule (Section 15.225)	Result
Fundamental emission	15.225 (a)	Pass
20 dB Bandwidth	15.215	Pass
Frequency Satiability	15.225 (e)	Pass
In band Radiated Emissions	15.225(b),15.225(c)	Pass
Out of band Radiated Emissions	15.225(d)	Pass
AC Power Line Conducted Emission	15.207	Pass
Antenna Requirement	15.203	Pass

1. General Information

1.1 Identification of the EUT

Product:	Peloton Tread Tablet
Model No.:	PLTN-TC1VS
Operating Frequency:	13.56 MHz
Access scheme:	ASK
Rated Power:	DC 24V from adapter
Power Cord:	N/A
Sample receiving date:	Apr. 10, 2018
Sample condition:	Workable
Test Date(s):	Apr. 23, 2018 ~ Apr. 27, 2018

1.2 Antenna description

Antenna Type : Loop Antenna
 Connector Type : I-PEX

1.3 Peripherals equipment

No.	Model no.	Specification
Adapter	EA10681V-240	I/P: 100-240V~, 2.0A,50-60Hz O/P: 24V, 3A

1.4 Operation mode

TX mode: The EUT transmit 13.56MHz signal continuously while we power on the EUT.

2. Fundamental emission

2.1 Operating environment

Temperature:	25	°C
Relative Humidity:	55	%
Atmospheric Pressure	1008	hPa
Requirement & Test method	15.225 (a)	

2.2 Limit for Fundamental emission

The field strength of any emissions within the band 13.553-13.567 MHz shall not exceed 15,848 uV/m(83.99 dBuV/m) at 30 meters.

2.3 Measuring instrument setting

Spectrum analyzer settings	
Spectrum Analyzer function	Setting
Detector	QP
RBW	10 kHz
Sweep	Auto couple
Trace	Max hold
Span	900 kHz
Attenuation	Auto

2.4 Test procedure

1. Configure the EUT according to ANSI C63.10:2013. The EUT was placed on the top of the turntable 0.8 meter above ground. The center of the receiving antenna mounted on the top of a height-variable antenna tower was placed 3 meters far away from the turntable.
2. Power on the EUT and all the companion devices. The turntable was rotated by 360 degree to find the position of the maximum emission level.
3. The height of the receiving antenna was one meter above ground to find the maximum emission field strength of the both plane and coaxial polarity
4. Set the test-receiver system to peak or CISPR quasi-peak detector with specified bandwidth under maximum hold mode.

2.5 Test diagram

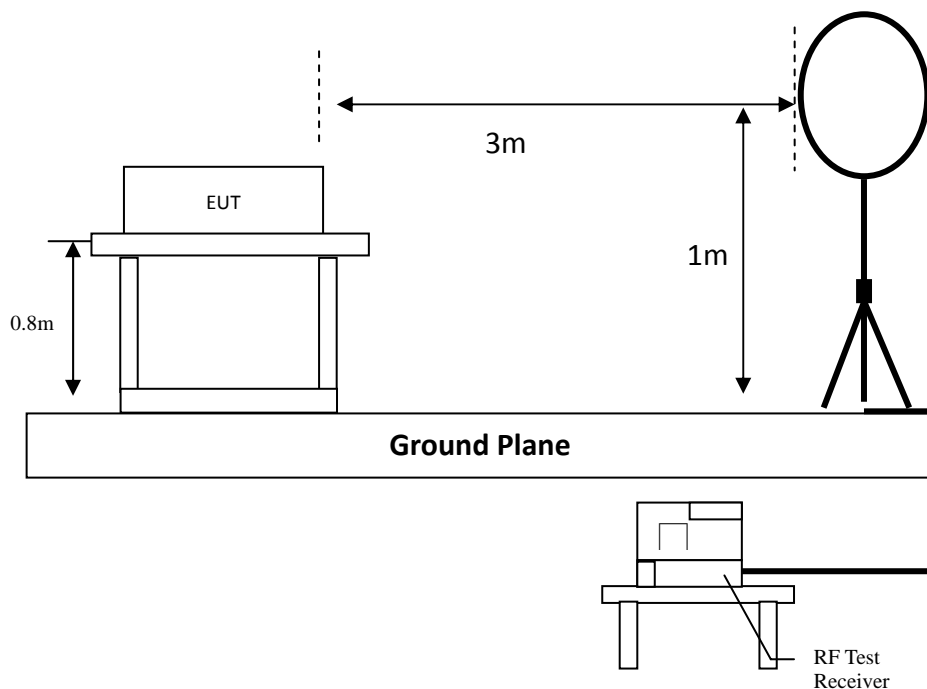

TEST REPORT

2.6 Test result

Polarity (circle)	Frequency (MHz)	Detection value	factor (dB/m)	Reading (dB μ V)	value (dB μ V/m)	Limit @ 3m (dB μ V/m)	Tolerance (dB)
Plane	13.56	QP	21.03	49.30	70.33	124.00	-53.67

13.56MHz , Limit= 84dBuV +40 dB (decade) = 124 dB

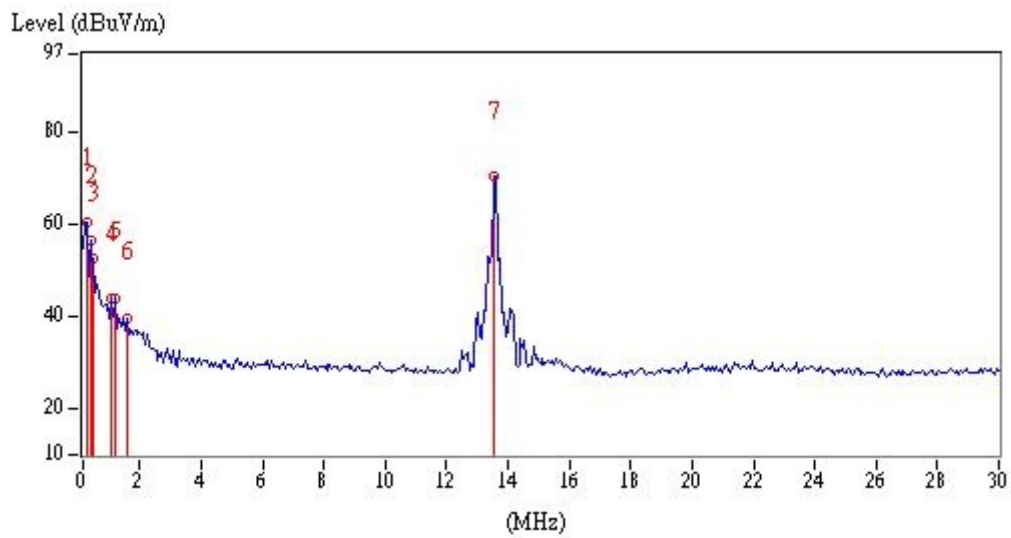

3. 20 dB Bandwidth

3.1 Operating environment

Temperature:	25	°C
Relative Humidity:	55	%
Atmospheric Pressure	1008	hPa
Requirement & Test method	15.215	

3.2 Limit for 20 dB bandwidth

None

3.3 Measuring instrument setting

Spectrum analyzer settings	
Spectrum Analyzer function	Setting
Detector	Peak
RBW	20kHz
VBW	62kHz
Sweep	Auto couple
Trace	Allow the trace to stabilize.
Span	\geq 1.2 times the 20 dB bandwidth
Attenuation	Auto

3.4 Test procedure

The 20 dB bandwidth was measured by spectrum analyzer connected to a receive antenna placed near the test sample while it is transmitting.

4. Frequency Satiability

4.1 Operating environment

Temperature:	25	°C
Relative Humidity:	55	%
Atmospheric Pressure	1008	hPa
Requirement & Test method	15.225(e)	

4.2 Limit for Frequency Satiability

The frequency tolerance of the carrier signal shall be maintained within $\pm 0.01\%$ of the operating frequency over a temperature variation of -20 degrees to $+50$ degrees C at normal supply voltage, and for a variation in the primary supply voltage from 85% to 115% of the rated supply voltage at a temperature of 20 degrees C.

4.3 Measuring instrument setting

Spectrum analyzer settings	
Spectrum Analyzer function	Setting
Detector	Peak
RBW	3kHz
VBW	9.1kHz
Sweep	Auto couple
Trace	Allow the trace to stabilize.
Span	Sufficient to see the complete emission BW
Attenuation	Auto

4.4 Test procedure

Turn the EUT on, and couple its output to a frequency counter or other frequency-measuring device of sufficient accuracy, considering the frequency tolerance with which the EUT shall comply.

4.5 Test result

Temperature	Measuring Frequency (MHz)	Voltage	Comparison Frequency	Difference (MHz)	Difference (%)	Limit (%)	Result
-20	13.560200	120Vac	13.56	0.000200	0.001475%	±0.01	Pass
-10	13.560210	120Vac	13.56	0.000210	0.001549%	±0.01	Pass
0	13.560200	120Vac	13.56	0.000200	0.001475%	±0.01	Pass
10	13.560200	120Vac	13.56	0.000200	0.001475%	±0.01	Pass
20	13.560210	120Vac	13.56	0.000210	0.001549%	±0.01	Pass
30	13.560190	120Vac	13.56	0.000190	0.001401%	±0.01	Pass
40	13.560190	120Vac	13.56	0.000190	0.001401%	±0.01	Pass
50	13.560190	120Vac	13.56	0.000190	0.001401%	±0.01	Pass
20	13.560210	102Vac	13.56	0.000210	0.001549%	±0.01	Pass
	13.560210	120Vac	13.56	0.000210	0.001549%	±0.01	Pass
	13.560200	138Vac	13.56	0.000200	0.001475%	±0.01	Pass

20°C 120Vdc

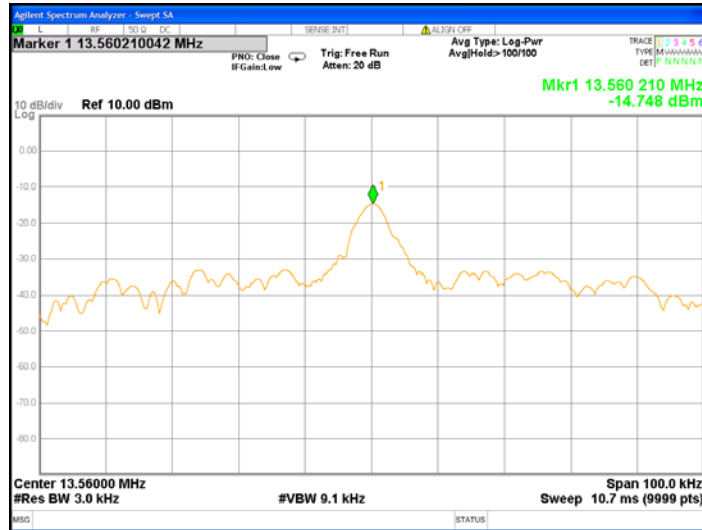

20°C 102Vdc



20°C 138Vac



-20°C

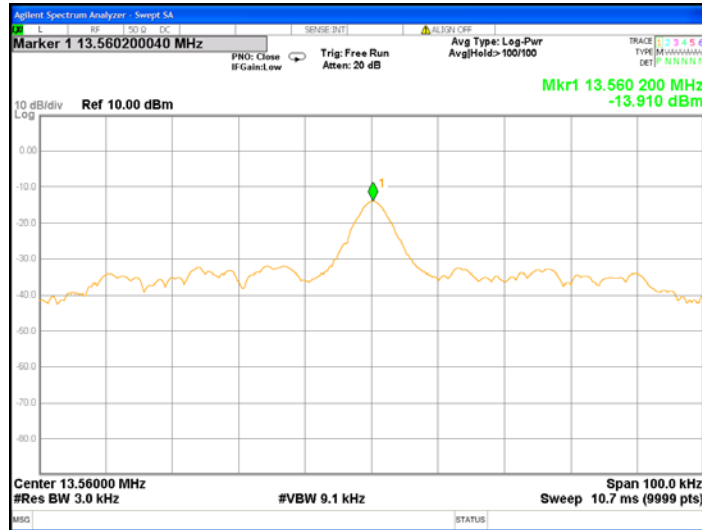

-10°C

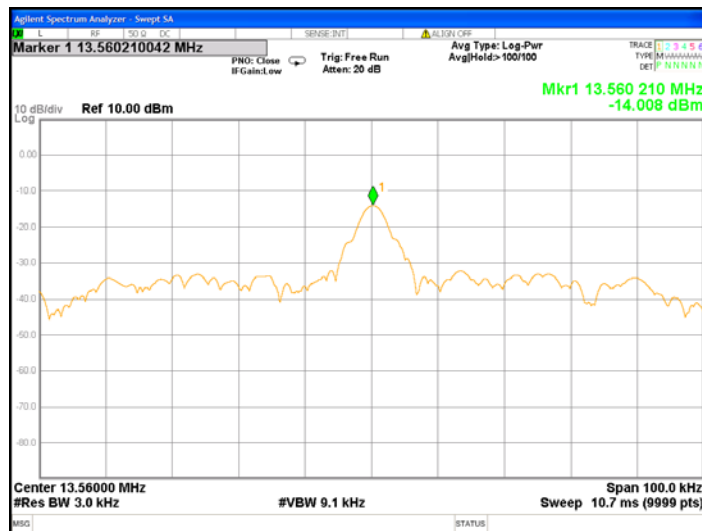

0°C

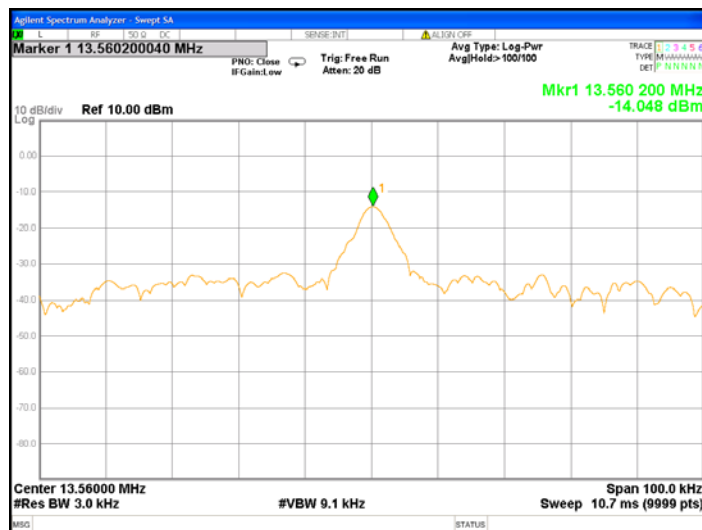

10°C

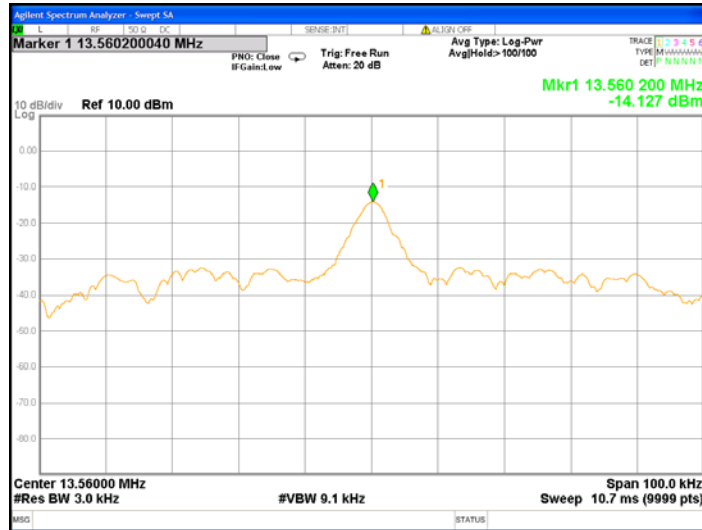

30°C

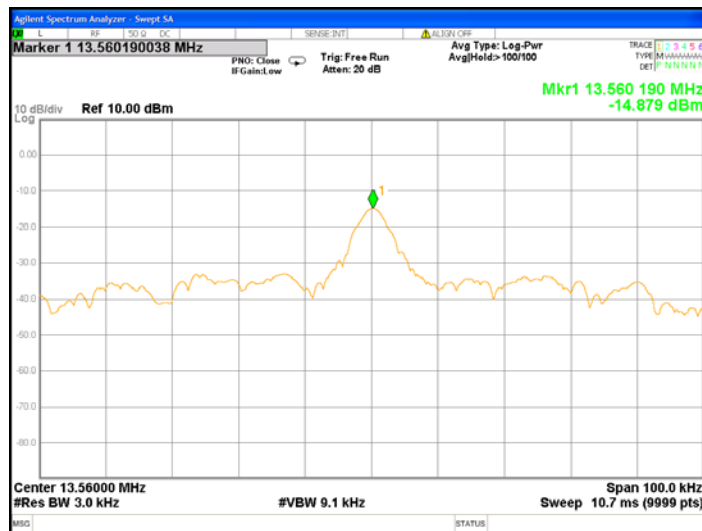

40°C

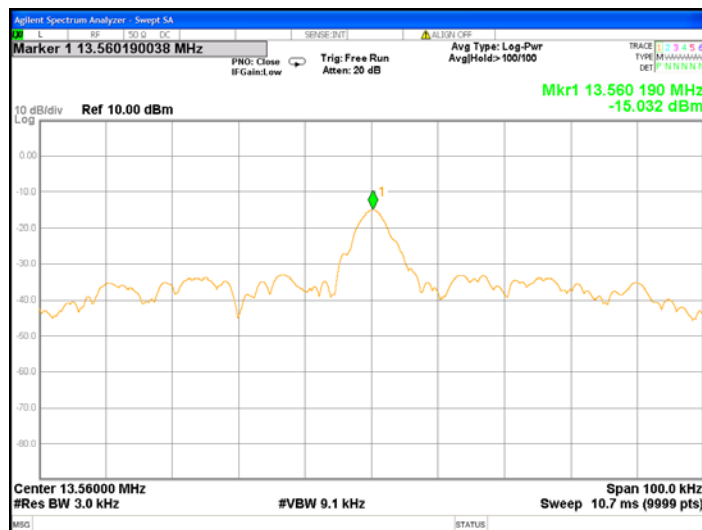

50°C

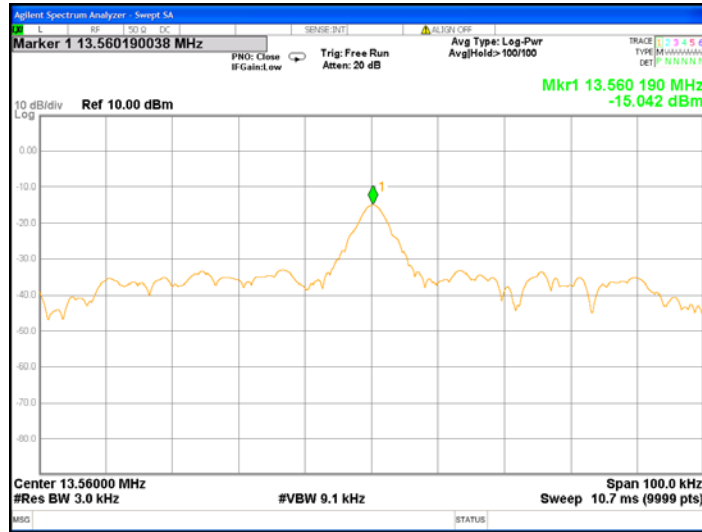

5. In band Radiated Emissions

5.1 Operating environment

Temperature:	25	°C
Relative Humidity:	55	%
Atmospheric Pressure	1008	hPa
Requirement	15.225(b),15.225(c)	

5.2 Limit for emissions in non-restricted frequency bands

Within the bands 13.410-13.553 MHz and 13.567-13.710 MHz, the field strength of any emissions shall not exceed 334 microvolts/meter at 30 meters.

Within the bands 13.110-13.410 MHz and 13.710-14.010 MHz the field strength of any emissions shall not exceed 106 microvolts/meter at 30 meters.

5.3 Measuring instruments setting

Spectrum analyzer settings	
Spectrum Analyzer function	Setting
Detector	QP
RBW	10 kHz
Sweep	Auto couple
Trace	Max hold
Span	900 kHz
Attenuation	Auto

5.4 Test procedure

1. Configure the EUT according to ANSI C63.10:2013. The EUT was placed on the top of the turntable 0.8 meter above ground. The center of the receiving antenna mounted on the top of a height-variable antenna tower was placed 3 meters far away from the turntable.
2. Power on the EUT and all the companion devices. The turntable was rotated by 360 degree to find the position of the maximum emission level.
3. The height of the receiving antenna is one meter above ground to find the maximum emission field strength of the both plane and coaxial polarity
4. Set the test-receiver system to peak or CISPR quasi-peak detector with specified bandwidth under maximum hold mode.

5.5 Test diagram

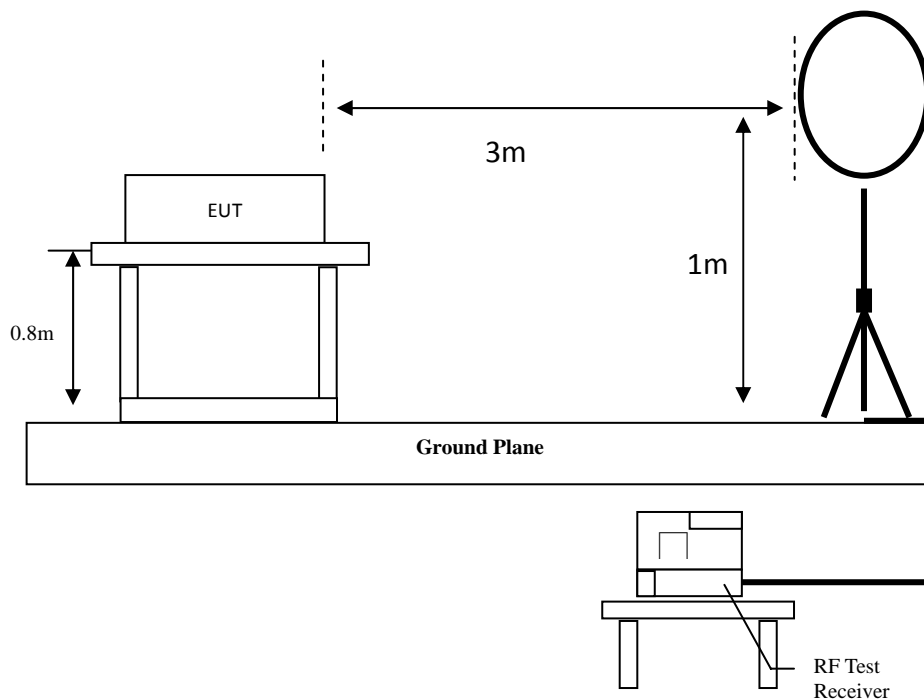

5.6 Test results

FCC 15.225 Mask @ NFC 13.56MHz

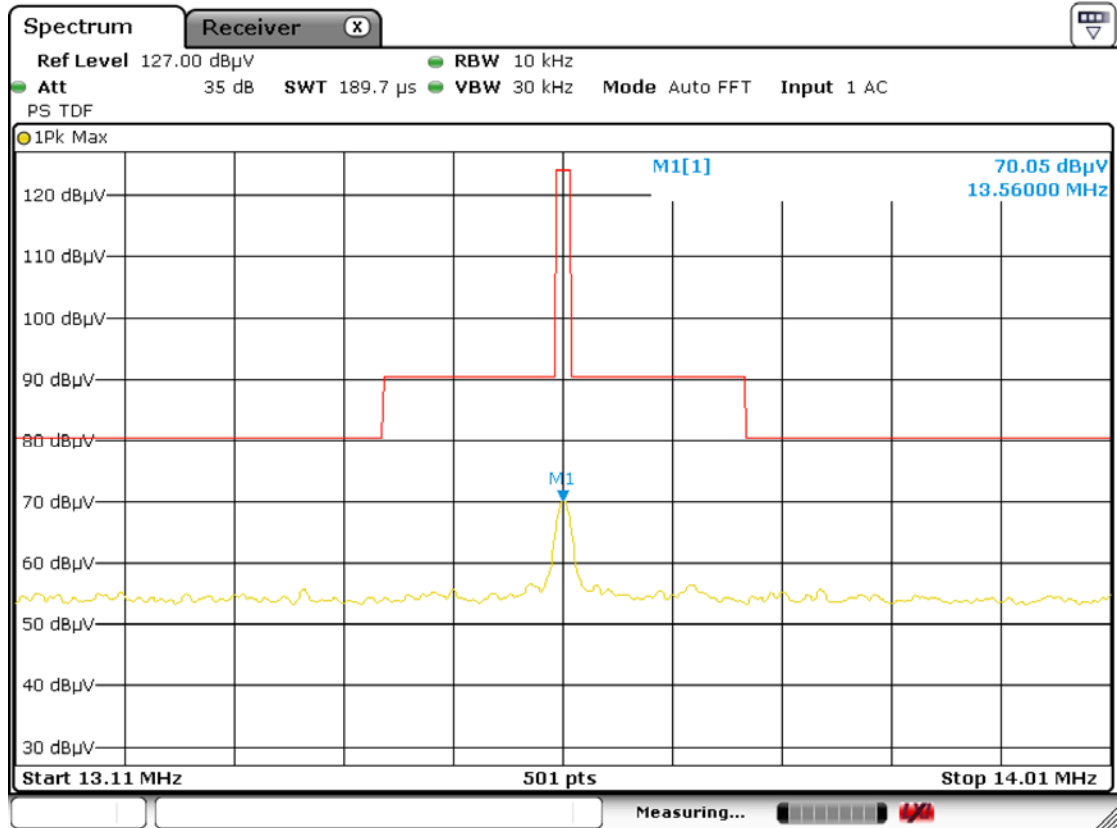

6. Out of band Radiated Emissions

6.1 Operating environment

Temperature:	25	°C
Relative Humidity:	55	%
Atmospheric Pressure	1008	hPa
Requirement	15.225(d), 15.205, 15.209	

6.2 Limit for emission in restricted frequency bands (Radiated emission measurement)

Frequency (MHz)	Field Strength (microvolts/meter)	Measurement distance (meters)
0.009~0.490	2400/F(kHz)	300
0.490~1.705	2400/F(kHz)	30
1.705~30	30	30
30-88	100	3
88-216	150	3
216-960	200	3
Above 960	500	3

Remark:

1. In the above table, the tighter limit applies at the band edges.
2. Distance refers to the distance in meters between the measuring instrument antenna and the closed point of any part of the device or system

6.3 Measuring instrument setting

Receiver settings	
Receiver function	Setting
Detector	QP
RBW	9-150 kHz ; 200-300 Hz 0.15-30 MHz; 9-10 kHz 30-1000 MHz; 100-120 kHz
VBW	$\geq 3 \times \text{RBW}$
Sweep	Auto couple
Attenuation	Auto

6.4 Test procedure

1. Configure the EUT according to ANSI C63.10:2013. The EUT was placed on the top of the turntable 0.8 meter above ground. The center of the receiving antenna mounted on the top of a height-variable antenna tower was placed 3 meters far away from the turntable.
2. Power on the EUT and all the companion devices. The turntable was rotated by 360 degree to find the position of the maximum emission level.
3. The height of the receiving antenna was varied between one meter and four meters above ground to find the maximum emission field strength of the both horizontal and vertical polarization
4. If find the frequencies above the limit or below within 3dB, the antenna tower was scan (from 1m to 4m) and then the turntable was rotated to find the maximum reading.
5. Set the test-receiver system to peak or CISPR quasi-peak detector with specified bandwidth under maximum hold mode.
6. If the emissions level of the EUT in peak mode was 3dB lower than the average limit specified then testing will be stopped and peak values of the EUT will be reported. Otherwise, the emissions which do not have 3dB margin will be measured using the quasi-peak method for below 1GHz.
7. In case the emission is lower than 30MHz, loop antenna has to be used for measurement and the recorded data should be quasi-peak measured by receiver.

6.5 Test configuration

6.5.1 Radiated emission from 9kHz to 30MHz uses Loop Antenna:

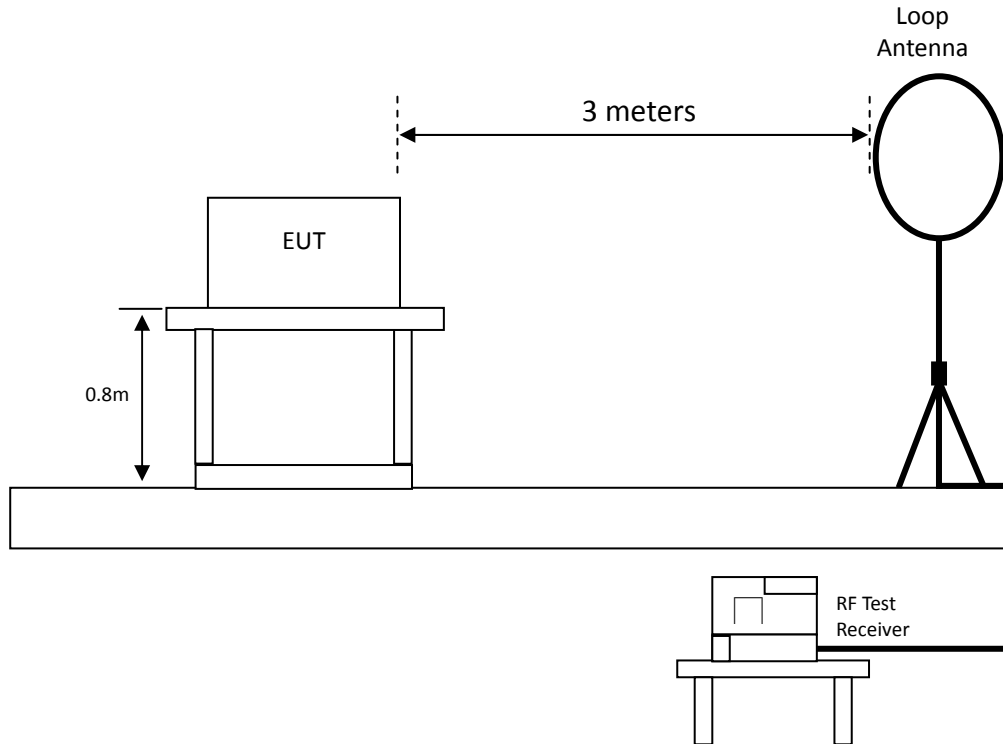

6.5.2 Radiated emission below 1GHz using Bilog Antenna

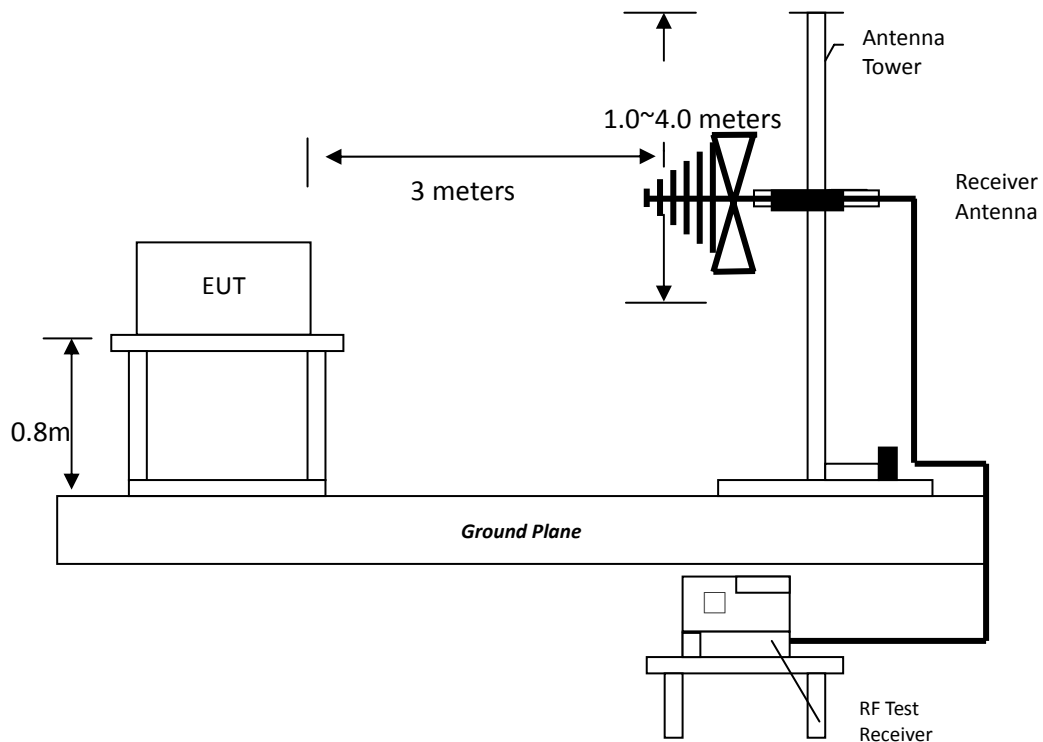

6.6 Test result

6.6.1 Measurement results: frequency range from 9 kHz to 30 MHz

The test was performed on EUT under continuously transmitting mode.

EUT : PLTN-TC1VS

Worst Case : Tx mode

Polarity (circle)	Frequency (MHz)	Detection value	factor (dB/m)	Reading (dBμV)	value (dBμV/m)	Limit @ 3m (dBμV/m)	Tolerance (dB)
H	0.02	PK	19.25	27.76	47.01	121.58	-74.57
H	0.06	PK	18.95	35.29	54.24	112.04	-57.80
H	0.07	PK	18.92	34.13	53.05	110.70	-57.65
H	0.09	QP	18.78	24.78	43.56	108.52	-64.96
H	0.10	PK	18.74	24.38	43.12	107.60	-64.48
H	0.14	PK	18.74	44.20	62.94	104.68	-41.74
H	0.27	PK	18.76	41.59	60.35	98.98	-38.63
H	0.39	QP	18.71	37.66	56.37	95.78	-39.41
H	0.51	QP	18.64	33.79	52.43	73.45	-21.02
H	1.05	QP	18.61	25.30	43.91	67.18	-23.27
H	1.22	QP	18.59	25.35	43.94	65.88	-21.94
H	1.58	QP	18.56	21.22	39.78	63.63	-23.85

Remark:

1. Corr. Factor = Antenna Factor + Cable Loss
2. Corrected Level = Reading + Corr. Factor

Note: The amplitude of spurious emissions that are attenuated by more than 20dB below the permissible value has no need to be reported.

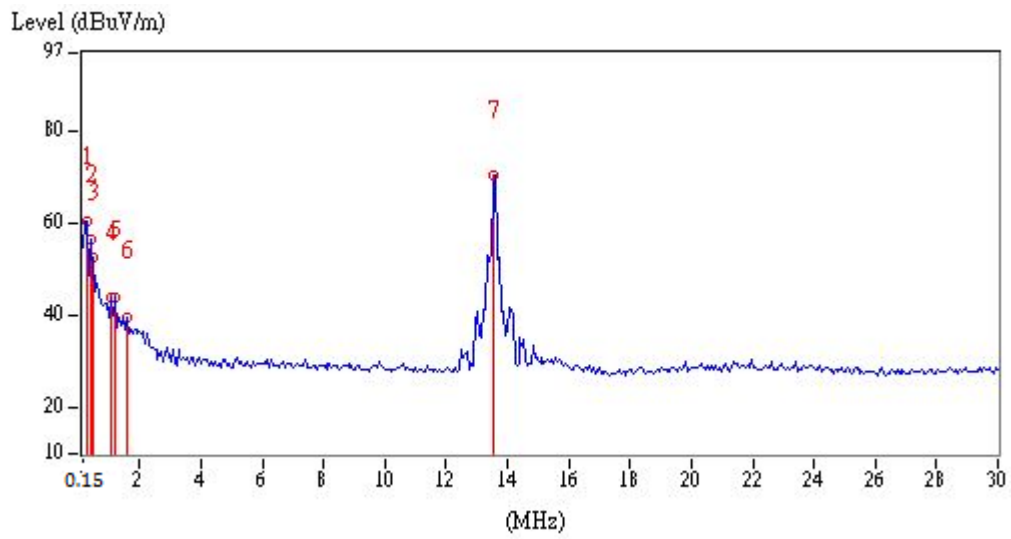
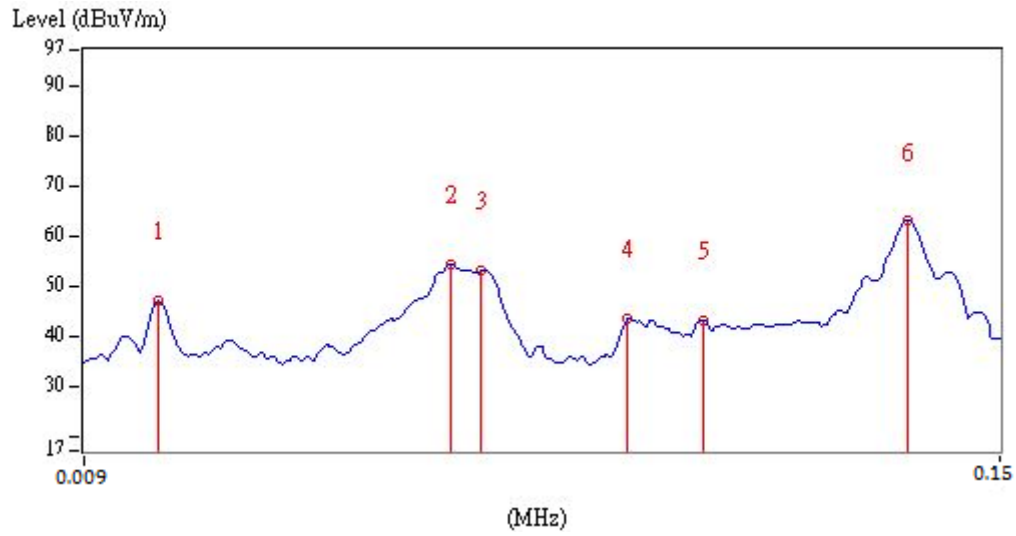

TEST REPORT

6.6.2 Measurement results: frequencies below 1 GHz

The test was performed on EUT under continuously transmitting mode.

EUT : PLTN-TC1VS

Worst Case : Tx mode

Ant. Pol. (H/V)	Frequency (MHz)	Spectrum Analyzer Detector	Correction Factor (dB/m)	Reading (dBμV)	Corrected Reading (dBμV/m)	Limit @ 3 m (dBμV/m)	Margin (dB)
Vertical	37.56	QP	19.64	11.12	30.76	40.00	-9.24
Vertical	40.26	QP	19.97	10.03	30.00	40.00	-10.00
Vertical	49.44	QP	20.55	10.44	30.99	40.00	-9.01
Vertical	74.82	QP	17.15	11.76	28.91	40.00	-11.09
Vertical	80.76	QP	15.89	11.12	27.01	40.00	-12.99
Vertical	92.10	QP	14.64	16.23	30.87	43.50	-12.63
Vertical	103.98	QP	16.02	14.44	30.46	43.50	-13.04

Remark:

1. Corr. Factor = Antenna Factor + Cable Loss
2. Corrected Level = Reading + Corr. Factor

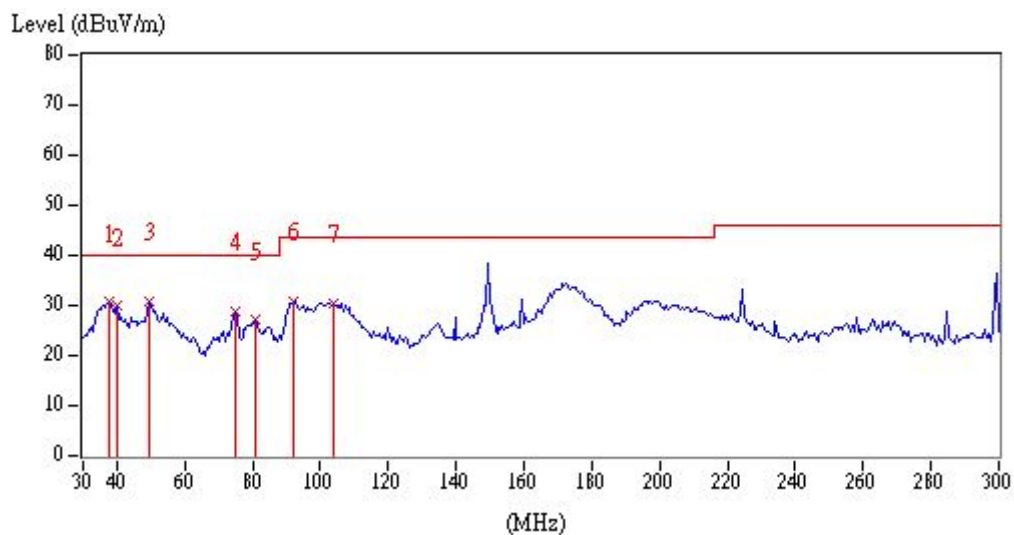

TEST REPORT

EUT : PLTN-TC1VS

Worst Case : Tx mode

Ant. Pol. (H/V)	Frequency (MHz)	Spectrum Analyzer Detector	Correction Factor (dB/m)	Reading (dBμV)	Corrected Reading (dBμV/m)	Limit @ 3 m (dBμV/m)	Margin (dB)
Horizontal	38.64	QP	19.78	1.10	20.88	40.00	-19.12
Horizontal	91.02	QP	14.55	7.88	22.43	43.50	-21.07
Horizontal	96.42	QP	15.03	4.69	19.72	43.50	-23.78
Horizontal	107.76	QP	16.67	3.05	19.72	43.50	-23.78
Horizontal	116.94	QP	17.56	2.00	19.56	43.50	-23.94
Horizontal	125.58	QP	18.40	1.58	19.98	43.50	-23.52
Horizontal	38.64	QP	19.78	1.10	20.88	40.00	-19.12

Remark:

1. Corr. Factor = Antenna Factor + Cable Loss
2. Corrected Level = Reading + Corr. Factor

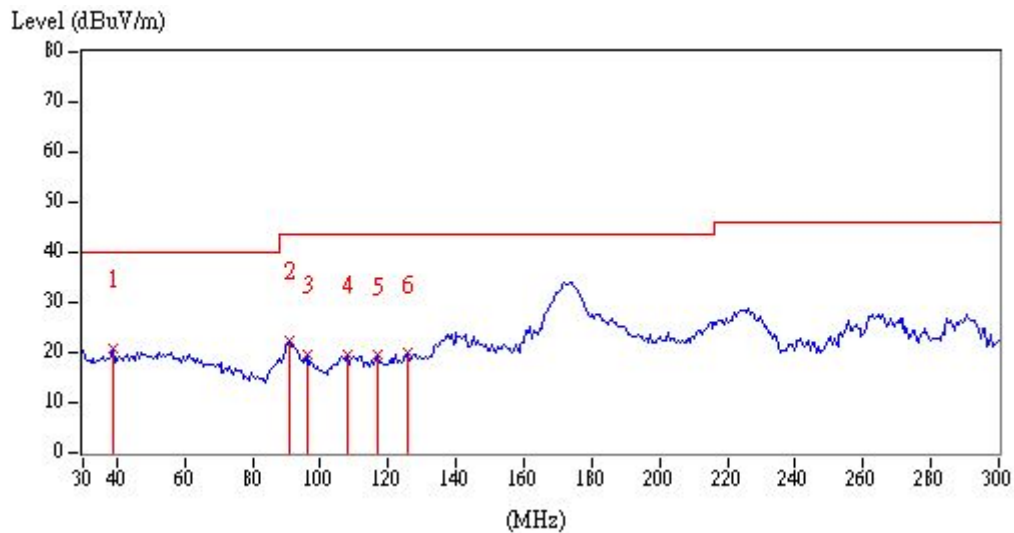

7. AC Power Line Conducted Emission

7.1 Measuring instrument setting

Receiver Function	Setting
Detector	QP
Start frequency	0.15MHz
Stop frequency	30MHz
IF bandwidth	9 kHz
Attenuation	10dB

7.2 Test Procedure

Step 1	Configure the EUT according to ANSI C63.10:2013. The EUT or host of EHT has to be placed 0.4 meter far from the conducting wall of the shielding room and at least 80 centimeters from any other grounded conducting surface.
Step 2	Connect EUT or host of EUT to the power mains through a line impedance stabilization network.
Step 3	All the companion devices are connected to the other LISN. The LISN should provide 50Uh/50ohms coupling impedance.
Step 4	The frequency range from 150 kHz to 30MHz was searched.
Step 5	Set the test-receiver system to peak detector and specified bandwidth with maximum hold mode.
Step 6	The measurement has to be done between each power line and ground at the power terminal.

7.3 Test Diagram

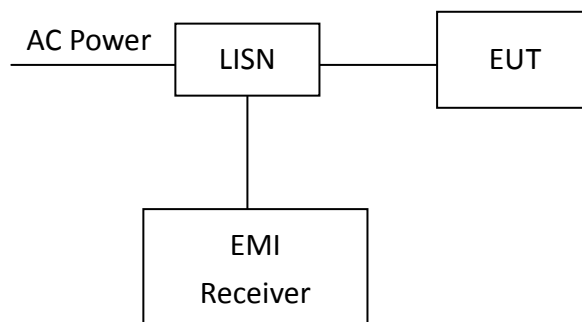

7.4 Limit

Frequency (MHz)	Conducted Limit (dBuV)	
	Q.P.	Ave.
0.15~0.50	66 – 56	56 – 46
0.50~5.00	56	46
5.00~30.0	60	50

7.5 Operating Environment Condition

Temperature (°C) :	26
Relative Humidity (%) :	68
Atmospheric Pressure (hPa) :	1010
Test Date :	2018/04/27

TEST REPORT

7.6 Test Results

Phase: Live Line
 Model No.: PLTN-TC1VS
 Test Condition: Tx mode

Frequency (MHz)	Corr. Factor (dB)	Reading QP (dBuV)	Level QP (dBuV)	Limit QP (dBuV)	Reading AV (dBuV)	Level AV (dBuV)	Limit AV (dBuV)	Margin (dB)	
								QP	AV
0.193	9.34	42.65	51.99	63.89	34.96	44.30	53.89	-11.90	-9.59
0.262	9.35	36.70	46.05	61.38	23.87	33.22	51.38	-15.33	-18.16
0.329	9.36	30.55	39.90	59.49	21.75	31.11	49.49	-19.58	-18.38
0.521	9.38	29.39	38.77	56.00	19.83	29.21	46.00	-17.23	-16.79
0.830	9.40	26.95	36.35	56.00	17.67	27.07	46.00	-19.65	-18.93
15.470	9.54	33.51	43.05	60.00	26.59	36.13	50.00	-16.95	-13.87

Remark:

1. Corr. Factor (dB) = LISN Factor (dB) + Cable Loss (dB)
2. Level (dBuV) = Corr. Factor (dB) + Reading (dBuV)
3. Margin (dB) = Level (dBuV) – Limit (dBuV)

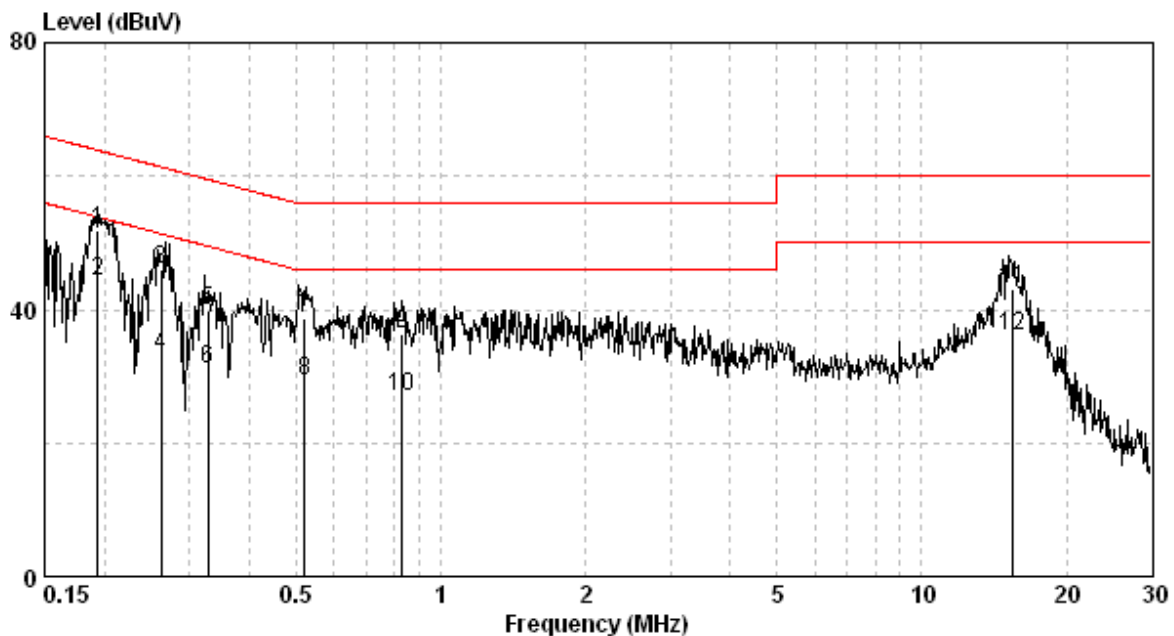

TEST REPORT

Phase: Neutral Line
 Model No.: PLTN-TC1VS
 Test Condition: Tx mode

Frequency (MHz)	Corr. Factor (dB)	Reading QP (dBuV)	Level QP (dBuV)	Limit QP (dBuV)	Reading AV (dBuV)	Level AV (dBuV)	Limit AV (dBuV)	Margin (dB)	
								QP	AV
0.197	9.60	42.49	52.09	63.76	33.75	43.35	53.76	-11.66	-10.41
0.252	9.61	37.02	46.63	61.69	26.88	36.48	51.69	-15.06	-15.20
0.336	9.61	30.09	39.70	59.31	20.03	29.64	49.31	-19.61	-19.67
0.444	9.62	27.86	37.48	56.98	17.23	26.85	46.98	-19.50	-20.13
0.516	9.62	28.52	38.15	56.00	17.89	27.51	46.00	-17.85	-18.49
15.146	9.85	35.19	45.04	60.00	27.81	37.66	50.00	-14.96	-12.34

Remark:

1. Corr. Factor (dB) = LISN Factor (dB) + Cable Loss (dB)
2. Level (dBuV) = Corr. Factor (dB) + Reading (dBuV)
3. Margin (dB) = Level (dBuV) – Limit (dBuV)

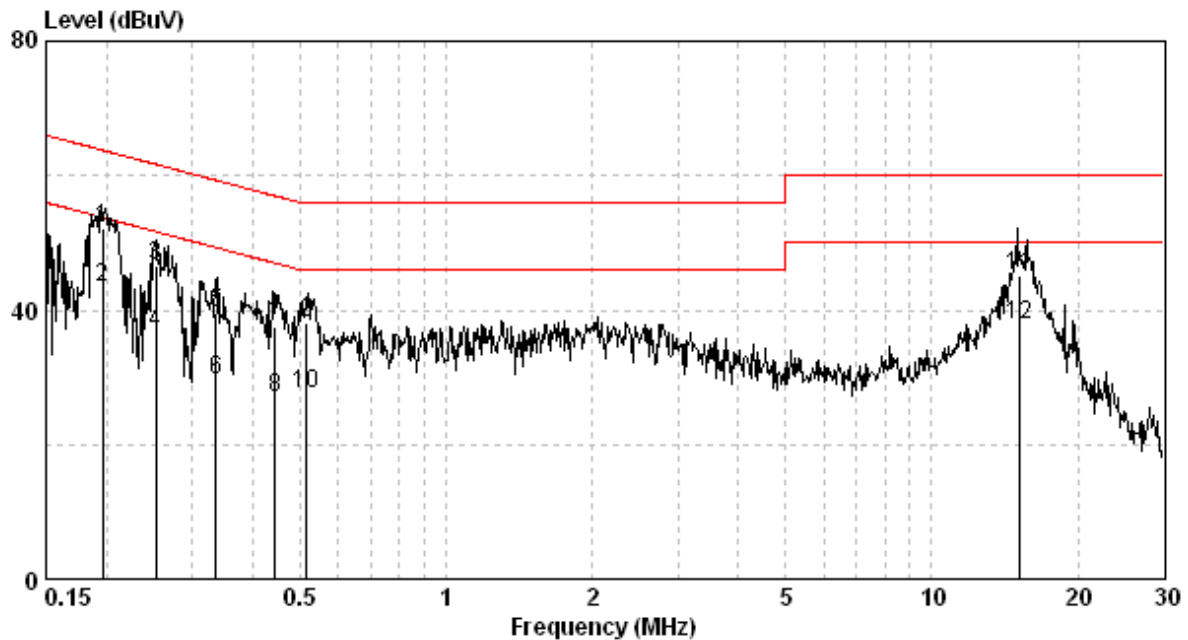

Appendix A: Test equipment list

Test Equipment/ Test site	Brand	Model No.	Serial No.	Calibration Date	Next Calibration Date
ESCI EMI Test Receiver	Rohde & Schwarz	ESCI	100018	2017/11/21	2018/11/20
Spectrum Analyzer	Rohde & Schwarz	FSP30	100245	2018/02/23	2019/02/22
Horn Antenna (1-18G)	SHWARZBECK	BBHA 9120 D	9120D-456	2018/01/23	2019/01/22
Horn Antenna (14-42G)	SHWARZBECK	BBHA 9170	BBHA9170159	2017/09/04	2020/09/02
Broadband Antenna	SHWARZBECK	VULB 9168	9168-172	2017/04/05	2018/04/04
Broadband Antenna	SHWARZBECK	VULB 9168	9168-172	2018/04/23	2019/04/22
Pre-Amplifier	EMC Co.	EMC12635SE	980205	2017/11/28	2018/11/27
Pre-Amplifier	MITEQ	JS4-26004000--27-8A	828825	2017/08/23	2018/08/22
Power Meter	Anritsu	ML2495A	0844001	2017/10/18	2018/10/17
Power Sensor	Anritsu	MA2411B	0738452	2017/05/23	2018/05/22
Signal Analyzer	Agilent	N9030A	MY51380492	2017/08/29	2018/08/28
966-2(A) Cable 9kHz~26.5GHz	SUHNER	SMA / EX 100	N/A	2017/08/15	2018/08/14
966-2(B) Cable 9kHz~26.5GHz	SUHNER	SUCOFLEX 104P	CB0005	2017/08/15	2018/08/14
RF Cable 9kHz~26.5GHz	SUHNER	SUCOFLEX 102	CB0006	2017/05/04	2018/05/03

Note: No Calibration Required (NCR).

Test Equipment/ Test site	Brand	Model No.	Serial No.	Calibration Date	Next Calibration Date
966-2_3m Semi-Anechoic Chamber	966_2	CEM-966_2	N/A	2017/03/29	2018/03/28
966-2_3m Semi-Anechoic Chamber	966_2	CEM-966_2	N/A	2018/03/28	2019/03/27
High Pass Filter	Wainwright	WHKX3.0/ 18G-12SS	N/A	2017/06/02	2018/06/01
Active Loop Antenna	SCHWARZBECK MESS-ELEKTRONIC	FMZB1519	1519-067	2017/03/30	2018/03/29
Active Loop Antenna	SCHWARZBECK MESS-ELEKTRONIC	FMZB1519	1519-067	2018/04/17	2019/04/16
EMI Receiver	R&S	ESCI	100059	2017/11/13	2018/11/12
Two-Line V-Network	R&S	ENV216	101159	2017/06/03	2018/06/02
Two-Line -V-Network	R&S	ESH3-Z5	825562/003	2017/09/04	2018/09/03
CON-1 Shielded Room	N/A	N/A	N/A	NCR	NCR
CON-1 Cable	SUHNER	SUCOFLEX-104	26438414	2018/05/03	2019/05/02
Test software	Audix	e3	4.20040112L	NCR	NCR

Note: No Calibration Required (NCR).

Appendix B: Measurement Uncertainty

This uncertainty represents an expanded uncertainty expressed at approximately the 95 % confidence level using a coverage factor of $k=2$.

Item	Uncertainty
Vertically polarized radiated disturbances from 30MHz~1GHz in a semi-anechoic chamber at a distance of 3m	5.14 dB
Horizontally polarized radiated disturbances from 30MHz~1GHz in a semi-anechoic chamber at a distance of 3m	5.22 dB
Vertically polarized Radiated disturbances from 1GHz~18GHz in a semi-anechoic chamber at a distance of 3m	3.64 dB
Horizontally polarized Radiated disturbances from 1GHz~18GHz in a semi-anechoic chamber at a distance of 3m	3.64 dB
Vertically polarized Radiated disturbances from 18GHz~40GHz in a semi-anechoic chamber at a distance of 3m	2.68 dB
Horizontally polarized Radiated disturbances from 18GHz~40GHz in a semi-anechoic chamber at a distance of 3m	2.68 dB
Conducted Output power	0.86 dB
Radiated electromagnetic disturbances in the frequency range from 9kHz to 30MHz	3.54 dB
Conducted disturbance measurements at a mains port from 9 kHz to 30 MHz using a 50 Ω /50 μ H +5 Ω artificial mains network (AMN)	2.48 dB