

Peloton Interactive Inc.

TEST REPORT

REPORT NUMBER
180600462TWN-001

ISSUE DATE

Sep. 11, 2018

PAGES
163

DOCUMENT CONTROL NUMBER

© 2018 INTERTEK



Radio Spectrum TEST REPORT

Applicant:	Peloton Interactive Inc. 125 W 25th St, 11th Floor, New York, NY 10001
Product:	Peloton Console Tablet
Model No.:	PLTN-RB1VO
Brand Name:	Peloton Console
FCC ID:	2AA3N- RB1VO
Test Method/ Standard:	47 CFR FCC Part 15.407 KDB 789033 D02 v02r01 ANSI C63.10 2013 KDB 662911 D01 v02r01
Test By:	Intertek Testing Services Taiwan Ltd., Hsinchu Laboratory No. 11, Lane 275, Ko-Nan 1 Street, Chia-Tung Li, Shiang-Shan District, Hsinchu City, Taiwan



Prepared and Checked by:

Approved by:

*Durant Wei**Maxy You*

Durant Wei
Engineer

Maxy You
Engineer

This report is for the exclusive use of Intertek's Client and is provided pursuant to the agreement between Intertek and its Client. Intertek's responsibility and liability are limited to the terms and conditions of the agreement. Intertek assumes no liability to any party, other than to the Client in accordance with the agreement, for any loss, expense or damage occasioned by the use of this report. Only the Client is authorized to permit copying or distribution of this report and then only in its entirety. Any use of the Intertek name or one of its marks for the sale or advertisement of the tested material, product or service must first be approved in writing by Intertek. The observations and test results in this report are relevant only to the sample tested. This report by itself does not imply that the material, product, or service is or has ever been under an Intertek certification program.

Revision History

Report No.	Issue Date	Revision Summary
180600462TWN-001	Sep. 11, 2018	Original report

Table of Contents

Summary of Test Data	5
1. General Information	6
1.1 Identification of the EUT	6
1.2 Description of the EUT	6
1.3 Antenna description	7
1.4 Peripherals equipment	7
1.5 Operation mode	8
1.6 Applied test modes and channels	12
2. Maximum Conducted Output Power	13
2.1 Operating environment	13
2.2 Limit for maximum output power	13
2.3 Measuring instrument setting	13
2.4 Test procedure	13
2.5 Test diagram	13
2.6 Test results	14
3. Power Spectrum Density	16
3.1 Operating environment	16
3.2 Limit for power spectrum density	16
3.3 Measuring instrument setting	16
3.4 Test procedure	17
3.5 Test diagram	17
3.6 Test results	18
4. Minimum Bandwidth	46
4.1 Operating environment	46
4.2 Limit for minimum emission bandwidth	46
4.3 Measuring instrument setting	46
4.4 Test procedure	47
4.5 Test diagram	47
4.6 Test results	48
5. Emissions in Restricted Frequency Bands (Radiated emission measurements)	103
5.1 Operating environment	103
5.2 Limit for emission in restricted frequency bands (Radiated emission measurement)	103
5.3 Measuring instrument setting	104
5.4 Test procedure	105
5.5 Test configuration	106
5.5.1 Radiated emission from 9 kHz to 30MHz using Loop Antenna	106
5.5.2 Radiated emission below 1GHz using Bilog Antenna	106
5.5.3 Radiated emission above 1GHz using Horn Antenna	107
5.6 Test results	107
5.6.1 Measurement results: frequencies from 9 kHz to 30MHz	107

TEST REPORT

- 5.6.2 Measurement results: frequencies from 30 MHz to 1GHz 109
- 5.6.3 Measurement results: frequency above 1GHz to 40GHz 111
- 6. Emission on The Band Edge..... 126
 - 6.1 Operating environment 126
 - 6.2 Measuring instrument setting 126
 - 6.3 Test procedure 126
 - 6.4 Test Result..... 127
- 7. Dynamic Frequency Selection (DFS) test 142
 - 7.1 Operating environment 142
 - 7.2 UNII Device Description..... 142
 - 7.2.1 Operating mode 143
 - 7.3 Test Protocol and Requirements 143
 - 7.4 DFS Detection Thresholds and Limitations of each Parameter 145
 - 7.5 Radar Test Waveforms 146
 - 7.6 Radar Waveform Calibration 149
 - 7.6.1 Radar Waveform Calibration Plots 150
 - 7.7 Test instruments and setup 151
 - 7.7.1 Deviation about the radar waveform 151
 - 7.7.2 Test setup 151
 - 7.8 DFS test results 151
 - 7.8.1 Test summary 151
 - 7.8.2 DFS test result..... 152
 - 7.8.2.1 Channel Move time 152
 - 7.8.2.2 Channel Closing Transmission Time 153
 - 7.8.2.3 Non-Occupancy Period 156
- 8.AC Power Line Conducted Emission 157
 - 8.1 Measuring instrument setting 157
 - 8.2 Test Procedure 157
 - 8.3 Test Diagram 157
 - 8.4 Limit 158
 - 8.5 Operating Environment Condition 158
 - 8.6 Test Results 159
- Appendix A: Test equipment list..... 161
- Appendix B: Measurement Uncertainty 163

Summary of Test Data

Test Requirement	Applicable Rule (Section 15.407)	Result
Maximum Conducted Output Power	15.407 (a)(1)/(2)/(3) KDB 789033 D02 v01r02	Pass
Power Spectrum Density	15.407 (a)(1)/(2)/(3) KDB 789033 D02 v01r02	Pass
Minimum Emission Bandwidth	15.407(a)(5), 15.407(e) KDB 789033 D02 v01r02	Pass
Emissions In Restricted Frequency Bands (Radiated emission measurements)	15.407(b), 15.209	Pass
Emission on The Band Edge	15.407(b), 15.209	Pass
Dynamic Frequency Selection (DFS)	15.407(h)(2)	Pass
AC Line Conducted Emission	15.407(b)(6) 15.207	Pass
Antenna requirement	15.203	Pass

1. General Information

1.1 Identification of the EUT

Product:	Peloton Console Tablet
Model No.:	PLTN-RB1VO
Operating Frequency:	1. 5180MHz~5240MHz 2. 5260MHz~5320MHz 3. 5500MHz~5700MHz 4. 5745MHz~5825MHz
Channel Number:	1. 4 channels for 5180MHz~5240MHz 2. 2 channels for 5260MHz~5320MHz 3. 5 channels for 5500MHz~5700MHz 4. 2 channels for 5745MHz~5825MHz
Access scheme:	OFDM
Rated Power:	DC 24V from adapter
Power Cord:	N/A
Sample receiving date:	Jun. 28, 2018
Sample condition:	Workable
Test Date(s):	Jul. 12, 2018 ~ Jul. 26, 2018

1.2 Description of the EUT

Modulation mode	Transmit path	
	Chain 0 / Main	Chain 1 / AUX
802.11 a	V	V
802.11 ac (VHT20)	V	V
802.11 ac (VHT40)	V	V
802.11 ac (VHT80)	V	V

1.3 Antenna description**Antenna 1**

Antenna Gain : 2.96 dBi
Antenna Type : PIFA antenna
Connector Type : I-Pex

Antenna 2

Antenna Gain : 3.63 dBi
Antenna Type : PIFA antenna
Connector Type : I-Pex

1.4 Peripherals equipment

No.	Model no.	Specification
Adapter	EA10681G-120	I/P: 100-240V~, 2.0A,50-60Hz O/P: 12V, 4.16A

1.5 Operation mode

- (1) TX mode: EUT use 「 AMPAK RFTestTool.apk 」 entering test mode , and Touchscreen to change different channel.
- (2) With individual verifying, the maximum output power were found out 1 Mbps data rate for 802.11a mode, 6 Mbps data rate for 802.11ac(VHT20) mode , 6.5 Mbps data rate for 802.11ac(VHT40) mode , 29.3 Mbps data rate for 802.11ac(VHT80) mode , the final tests were executed under these conditions recorded in this report individually.

802.11a Ch44 Chain0		802.11a Ch60 Chain0		802.11a Ch120 Chain0		802.11a Ch157 Chain0	
Data rate	AV (dBm)	Data rate	AV (dBm)	Data rate	AV (dBm)	Data rate	AV (dBm)
6	7.29	6	7.07	6	8.98	6	9.00
9	7.24	9	7.01	9	8.93	9	8.94
12	7.21	12	6.95	12	8.88	12	8.91
18	7.18	18	6.92	18	8.81	18	8.85
24	7.13	24	6.87	24	8.77	24	8.78
36	7.06	36	6.84	36	8.73	36	8.74
48	7.00	48	6.78	48	8.69	48	8.67
54	6.92	54	6.70	54	8.65	54	8.62

802.11a Ch44 Chain1		802.11a Ch60 Chain1		802.11a Ch120 Chain1		802.11a Ch157 Chain1	
Data rate	AV (dBm)	Data rate	AV (dBm)	Data rate	AV (dBm)	Data rate	AV (dBm)
6	6.73	6	6.71	6	9.51	6	8.43
9	6.68	9	6.63	9	9.44	9	8.37
12	6.61	12	6.59	12	9.39	12	8.34
18	6.55	18	6.54	18	9.34	18	8.30
24	6.50	24	6.50	24	9.28	24	8.22
36	6.44	36	6.46	36	9.25	36	8.18
48	6.41	48	6.42	48	9.17	48	8.15
54	6.37	54	6.35	54	9.14	54	8.11

TEST REPORT

802.11ac(VHT20) Ch44 Chain0		802.11ac(VHT20) Ch60 Chain0		802.11ac(VHT20) Ch120 Chain0		802.11ac(VHT20) Ch157 Chain0	
Data rate	AV (dBm)	Data rate	AV (dBm)	Data rate	AV (dBm)	Data rate	AV (dBm)
6.5	6.90	6.5	6.84	6.5	8.76	6.5	8.71
13	6.84	13	6.79	13	8.71	13	8.65
19.5	6.78	19.5	6.75	19.5	8.64	19.5	8.62
26	6.75	26	6.71	26	8.60	26	8.54
39	6.70	39	6.66	39	8.55	39	8.50
52	6.63	52	6.62	52	8.49	52	8.46
58.5	6.59	58.5	6.54	58.5	8.42	58.5	8.41
65	6.55	65	6.47	65	8.38	65	8.33

802.11ac(VHT20) Ch44 Chain1		802.11ac(VHT20) Ch60 Chain1		802.11ac(VHT20) Ch120 Chain1		802.11ac(VHT20) Ch157 Chain1	
Data rate	AV (dBm)	Data rate	AV (dBm)	Data rate	AV (dBm)	Data rate	AV (dBm)
6.5	6.63	6.5	6.66	6.5	9.31	6.5	8.34
13	6.58	13	6.60	13	9.24	13	8.30
19.5	6.51	19.5	6.55	19.5	9.19	19.5	8.26
26	6.47	26	6.49	26	9.16	26	8.21
39	6.42	39	6.42	39	9.11	39	8.14
52	6.39	52	6.38	52	9.03	52	8.09
58.5	6.33	58.5	6.34	58.5	8.98	58.5	8.02
65	6.25	65	6.27	65	8.87	65	7.93

802.11ac(VHT20) Ch44 Chain0+1		802.11ac(VHT20) Ch60 Chain0+1		802.11ac(VHT20) Ch120 Chain0+1		802.11ac(VHT20) Ch157 Chain0+1	
Data rate	AV (dBm)	Data rate	AV (dBm)	Data rate	AV (dBm)	Data rate	AV (dBm)
13	9.78	13	9.76	13	12.05	13	11.54
26	9.74	26	9.71	26	12.01	26	11.47
39	9.69	39	9.66	39	11.94	39	11.42
52	9.61	52	9.59	52	11.90	52	11.38
78	9.55	78	9.52	78	11.84	78	11.31
104	9.50	104	9.44	104	11.78	104	11.27
117	9.43	117	9.40	117	11.72	117	11.23
130	9.37	130	9.33	130	11.69	130	11.18

TEST REPORT

802.11ac(VHT40) Ch38 Chain0		802.11ac(VHT40) Ch54 Chain0		802.11ac(VHT40) Ch118 Chain0		802.11ac(VHT40) Ch151 Chain0	
Data rate	AV (dBm)	Data rate	AV (dBm)	Data rate	AV (dBm)	Data rate	AV (dBm)
13.5	5.47	13.5	5.89	13.5	8.75	13.5	8.05
27	5.41	27	5.83	27	8.71	27	8.00
40.5	5.37	40.5	5.74	40.5	8.66	40.5	7.94
54	5.33	54	5.70	54	8.62	54	7.88
81	5.26	81	5.62	81	8.54	81	7.79
108	5.20	108	5.55	108	8.49	108	7.75
121	5.11	121	5.51	121	8.43	121	7.71
135	5.08	135	5.46	135	8.36	135	7.67

802.11ac(VHT40) Ch38 Chain1		802.11ac(VHT40) Ch54 Chain1		802.11ac(VHT40) Ch118 Chain1		802.11ac(VHT40) Ch151 Chain1	
Data rate	AV (dBm)	Data rate	AV (dBm)	Data rate	AV (dBm)	Data rate	AV (dBm)
13.5	5.08	13.5	5.74	13.5	8.81	13.5	7.73
27	5.02	27	5.68	27	8.74	27	7.68
40.5	4.95	40.5	5.62	40.5	8.70	40.5	7.62
54	4.91	54	5.54	54	8.59	54	7.57
81	4.87	81	5.49	81	8.53	81	7.51
108	4.82	108	5.41	108	8.48	108	7.44
121	4.74	121	5.35	121	8.42	121	7.38
135	4.69	135	5.29	135	8.37	135	7.30

802.11ac(VHT40) Ch38 Chain0+1		802.11ac(VHT40) Ch54 Chain0+1		802.11ac(VHT40) Ch118 Chain0+1		802.11ac(VHT40) Ch151 Chain0+1	
Data rate	AV (dBm)	Data rate	AV (dBm)	Data rate	AV (dBm)	Data rate	AV (dBm)
27	8.29	27	8.83	27	11.79	27	10.90
54	8.22	54	8.77	54	11.73	54	10.85
81	8.18	81	8.72	81	11.66	81	10.78
108	8.11	108	8.63	108	11.62	108	10.72
162	8.07	162	8.58	162	11.58	162	10.68
216	8.00	216	8.51	216	11.51	216	10.61
243	7.95	243	8.47	243	11.46	243	10.55
270	7.90	270	8.42	270	11.39	270	10.49

TEST REPORT

802.11ac(VHT80) Ch42 Chain0		802.11ac(VHT80) Ch58 Chain0		802.11ac(VHT80) Ch122 Chain0		802.11ac(VHT80) Ch155 Chain0	
Data rate	AV (dBm)	Data rate	AV (dBm)	Data rate	AV (dBm)	Data rate	AV (dBm)
29.3	1.85	29.3	2.25	29.3	4.70	29.3	4.45
58.5	1.81	58.5	2.21	58.5	4.62	58.5	4.41
87.8	1.74	87.8	2.13	87.8	4.58	87.8	4.37
117	1.69	117	2.07	117	4.51	117	4.32
175.5	1.62	175.5	2.00	175.5	4.44	175.5	4.26
234	1.57	234	1.96	234	4.39	234	4.20
263.3	1.52	263.3	1.92	263.3	4.32	263.3	4.14
292.5	1.44	292.5	1.86	292.5	4.27	292.5	4.03

802.11ac(VHT80) Ch42 Chain1		802.11ac(VHT80) Ch58 Chain1		802.11ac(VHT80) Ch122 Chain1		802.11ac(VHT80) Ch155 Chain1	
Data rate	AV (dBm)	Data rate	AV (dBm)	Data rate	AV (dBm)	Data rate	AV (dBm)
29.3	1.38	29.3	1.90	29.3	4.33	29.3	4.51
58.5	1.32	58.5	1.84	58.5	4.27	58.5	4.44
87.8	1.27	87.8	1.81	87.8	4.21	87.8	4.39
117	1.21	117	1.76	117	4.16	117	4.35
175.5	1.15	175.5	1.68	175.5	4.10	175.5	4.27
234	1.10	234	1.62	234	4.06	234	4.22
263.3	1.06	263.3	1.54	263.3	4.00	263.3	4.16
292.5	1.02	292.5	1.47	292.5	3.94	292.5	4.10

802.11ac(VHT80) Ch42 Chain0+1		802.11ac(VHT80) Ch58 Chain0+1		802.11ac(VHT80) Ch122 Chain0+1		802.11ac(VHT80) Ch155 Chain0+1	
Data rate	AV (dBm)	Data rate	AV (dBm)	Data rate	AV (dBm)	Data rate	AV (dBm)
58.5	4.63	58.5	5.09	58.5	7.53	58.5	7.49
117	4.55	117	5.02	117	7.46	117	7.43
175.5	4.47	175.5	4.97	175.5	7.41	175.5	7.38
234	4.43	234	4.93	234	7.33	234	7.32
351	4.38	351	4.85	351	7.29	351	7.24
468	4.33	468	4.81	468	7.22	468	7.20
526.5	4.28	526.5	4.78	526.5	7.17	526.5	7.14
585	4.21	585	7.69	585	7.11	585	7.07

TEST REPORT

1.6 Applied test modes and channels

Test items	Mode	Data Rate (Mbps)	Channel	Antenna
Maximum Conducted Output Power	802.11a	6	36,44,48,52,60,64,100,120,140,149,157,165	Chain0/Chain1
	802.11ac(VHT20)	13	36,44,48,52,60,64,100,120,140,149,157,165	Chain0+1
	802.11ac(VHT40)	27	38,46,54,62,102,118,134,151,159	Chain0+1
	802.11ac(VHT80)	58.5	42,58,106,122,155	Chain0+1
Power Spectrum Density	802.11a	6	36,44,48,52,60,64,100,120,140,149,157,165	Chain0/Chain1
	802.11ac(VHT20)	13	36,44,48,52,60,64,100,120,140,149,157,165	Chain0+1
	802.11ac(VHT40)	27	38,46,54,62,102,118,134,151,159	Chain0+1
	802.11ac(VHT80)	58.5	42,58,106,122,155	Chain0+1
Emission BW	802.11a	6	36,44,48,52,60,64,100,120,140,149,157,165	Chain0/Chain1
	802.11ac(VHT20)	6.5	36,44,48,52,60,64,100,120,140,149,157,165	Chain0/Chain1
	802.11ac(VHT40)	13.5	38,46,54,62,102,118,134,151,159	Chain0/Chain1
	802.11ac(VHT80)	29.3	42,58,106,122,155	Chain0/Chain1
Radiated spurious Emission 9kHz~1GHz	Worst Case			
Emissions In Restricted Frequency Bands (Radiated emission measurements)	802.11a	6	36,44,48,52,60,64,100,120,140,149,157,165	Chain0/Chain1
	802.11ac(VHT20)	13	36,44,48,52,60,64,100,120,140,149,157,165	Chain0+1
	802.11ac(VHT40)	27	38,46,54,62,102,118,134,151,159	Chain0+1
	802.11ac(VHT80)	58.5	42,58,106,122,155	Chain0+1
Emission on The Band Edge	802.11a	6	36,44,48,52,60,64,100,120,140,149,157,165	Chain0/Chain1
	802.11ac(VHT20)	13	36,44,48,52,60,64,100,120,140,149,157,165	Chain0+1
	802.11ac(VHT40)	27	38,46,54,62,102,118,134,151,159	Chain0+1
	802.11ac(VHT80)	58.5	42,58,106,122,155	Chain0+1
AC Line Conducted Emission	Worst Case			

2. Maximum Conducted Output Power

2.1 Operating environment

Temperature:	25	
Relative Humidity:	50	%
Atmospheric Pressure	1008	hPa

2.2 Limit for maximum output power

Operating Frequency (MHz)	Conducted output power limit
5150~5725	< 0.25 W (24 dBm)
5725~5850	< 1 W (30 dBm)

Operating Frequency (MHz)	Maximum E.I.R.P. limit
5150~5725	< 1 W (30 dBm)
5725~5850	< 4 W (36 dBm)

2.3 Measuring instrument setting

Power meter for Nominal Bandwidth less than 65MHz	
Power meter	Setting
Bandwidth	65MHz bandwidth is greater than the EUT emission bandwidth
Detector	Average

2.4 Test procedure

Test procedures refer to clause E) 3) b) measurement using a gated RF average power meter of KDB 789033 D02 v01r02

Test procedures refer to clause E) 2) b) Method SA-1 of KDB 789033 D02 v01r02

2.5 Test diagram

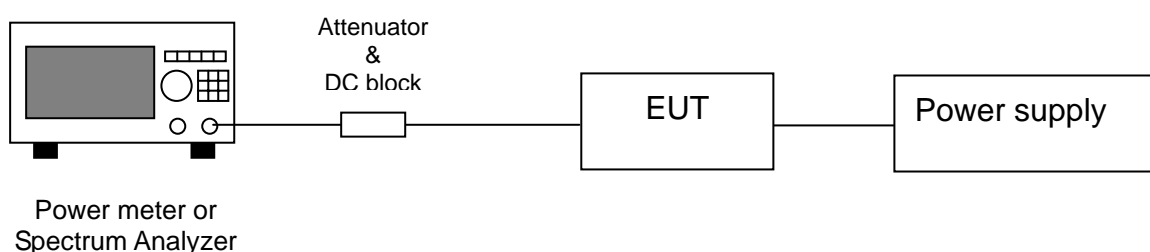

TEST REPORT

2.6 Test results

SISO

Mode	Channel	Frequency (MHz)	Output Power (AV)		Antenna Gain (dBi)	E.I.R.P. (dBm)	Limit of Conducted Power (dBm)	Margin (dB)	Limit of E.I.R.P. (dBm)	Margin (dB)
			dBm	mW						
802.11a (Chain0)	36	5180	7.13	5.16	2.96	10.09	24.00	-16.87	30.00	-19.91
	44	5220	7.29	5.36	2.96	10.25	24.00	-16.71	30.00	-19.75
	48	5240	7.12	5.15	2.96	10.08	24.00	-16.88	30.00	-19.92
	52	5260	7.26	5.32	2.96	10.22	24.00	-16.74	30.00	-19.78
	60	5300	7.07	5.09	2.96	10.03	24.00	-16.93	30.00	-19.97
	64	5320	6.66	4.63	2.96	9.62	24.00	-17.34	30.00	-20.38
	100	5500	8.17	6.56	2.96	11.13	24.00	-15.83	30.00	-18.87
	120	5600	8.98	7.91	2.96	11.94	24.00	-15.02	30.00	-18.06
	140	5700	9.91	9.79	2.96	12.87	24.00	-14.09	30.00	-17.13
	149	5745	9.34	8.59	2.96	12.30	30.00	-20.66	36.00	-23.70
	157	5785	9.00	7.94	2.96	11.96	30.00	-21.00	36.00	-24.04
165	5825	9.07	8.07	2.96	12.03	30.00	-20.93	36.00	-23.97	
802.11a (Chain1)	36	5180	9.68	9.29	3.63	13.31	24.00	-14.32	30.00	-16.69
	44	5220	6.73	4.71	3.63	10.36	24.00	-17.27	30.00	-19.64
	48	5240	6.53	4.50	3.63	10.16	24.00	-17.47	30.00	-19.84
	52	5260	6.92	4.92	3.63	10.55	24.00	-17.08	30.00	-19.45
	60	5300	6.71	4.69	3.63	10.34	24.00	-17.29	30.00	-19.66
	64	5320	6.44	4.41	3.63	10.07	24.00	-17.56	30.00	-19.93
	100	5500	8.48	7.05	3.63	12.11	24.00	-15.52	30.00	-17.89
	120	5600	9.51	8.93	3.63	13.14	24.00	-14.49	30.00	-16.86
	140	5700	10.03	10.07	3.63	13.66	24.00	-13.97	30.00	-16.34
	149	5745	8.61	7.26	3.63	12.24	30.00	-21.39	36.00	-23.76
	157	5785	8.43	6.97	3.63	12.06	30.00	-21.57	36.00	-23.94
165	5825	8.70	7.41	3.63	12.33	30.00	-21.30	36.00	-23.67	

MIMO

Mode	Ch	Freq (MHz)	Output Power (AV)		Total Power (AV)		Antenna 0 Gain (dBi)	Antenna 1 Gain (dBi)	E.I.R.P. (dBm)	Limit of Conducted Power (dBm)	Margin (dB)	Limit of E.I.R.P. (dBm)	Margin (dB)
			Chain 0	Chain 1	mW	dBm							
			dBm	dBm									
802.11ac (VHT20)	36	5180	6.86	6.72	9.55	9.80	2.96	3.63	13.10	24.00	-14.20	30.00	-16.90
	44	5220	6.90	6.63	9.50	9.78	2.96	3.63	13.07	24.00	-14.22	30.00	-16.93
	48	5240	6.93	6.43	9.33	9.70	2.96	3.63	12.99	24.00	-14.30	30.00	-17.01
	52	5260	6.97	6.79	9.75	9.89	2.96	3.63	13.19	24.00	-14.11	30.00	-16.81
	60	5300	6.84	6.66	9.47	9.76	2.96	3.63	13.06	24.00	-14.24	30.00	-16.94
	64	5320	6.40	6.16	8.50	9.29	2.96	3.63	12.59	24.00	-14.71	30.00	-17.41
	100	5500	7.96	8.54	13.40	11.27	2.96	3.63	14.60	24.00	-12.73	30.00	-15.40
	120	5600	8.76	9.31	16.05	12.05	2.96	3.63	15.38	24.00	-11.95	30.00	-14.62
	140	5700	9.79	9.90	19.30	12.86	2.96	3.63	16.17	24.00	-11.14	30.00	-13.83
	149	5745	9.10	8.62	15.41	11.88	2.96	3.63	15.17	30.00	-18.12	36.00	-20.83
	157	5785	8.71	8.34	14.25	11.54	2.96	3.63	14.83	30.00	-18.46	36.00	-21.17
	165	5825	8.98	8.66	15.25	11.83	2.96	3.63	15.13	30.00	-18.17	36.00	-20.87
802.11ac (VHT40)	38	5190	5.47	5.08	6.74	8.29	2.96	3.63	11.58	24.00	-15.71	30.00	-18.42
	46	5230	5.83	5.00	6.99	8.45	2.96	3.63	11.72	24.00	-15.55	30.00	-18.28
	54	5270	5.89	5.74	7.63	8.83	2.96	3.63	12.13	24.00	-15.17	30.00	-17.87
	62	5310	5.78	5.76	7.55	8.78	2.96	3.63	12.09	24.00	-15.22	30.00	-17.91
	102	5510	7.16	7.46	10.77	10.32	2.96	3.63	13.64	24.00	-13.68	30.00	-16.36
	118	5590	8.75	8.81	15.10	11.79	2.96	3.63	15.10	24.00	-12.21	30.00	-14.90
	134	5670	8.79	8.64	14.88	11.73	2.96	3.63	15.03	24.00	-12.27	30.00	-14.97
	151	5755	8.05	7.73	12.31	10.90	2.96	3.63	14.20	30.00	-19.10	36.00	-21.80
	159	5795	8.06	7.97	12.66	11.03	2.96	3.63	14.33	30.00	-18.97	36.00	-21.67
802.11ac (VHT80)	42	5210	1.85	1.38	2.91	4.63	2.96	3.63	7.92	24.00	-19.37	30.00	-22.08
	58	5290	2.25	1.90	3.23	5.09	2.96	3.63	8.38	24.00	-18.91	30.00	-21.62
	106	5530	3.43	3.27	4.33	6.36	2.96	3.63	9.66	24.00	-17.64	30.00	-20.34
	122	5610	4.70	4.33	5.66	7.53	2.96	3.63	10.82	24.00	-16.47	30.00	-19.18
	155	5775	4.45	4.51	5.61	7.49	2.96	3.63	10.80	30.00	-22.51	36.00	-25.20

3. Power Spectrum Density

3.1 Operating environment

Temperature:	25	
Relative Humidity:	50	%
Atmospheric Pressure	1008	hPa

3.2 Limit for power spectrum density

Operating Frequency (MHz)	Power density limit
5150~5725	< 11 dBm/1MHz
5725~5850	< 30 dBm/500kHz

3.3 Measuring instrument setting

Spectrum analyzer settings (5150~5725MHz)	
Spectrum Analyzer function	Setting
Detector	RMS
RBW	=1MHz
VBW	3 MHz
Sweep	Auto couple
Trace	Average
Span	Encompass the 26 dB EBW
Attenuation	Auto
Sweep point	≥ 2 Span / RBW

Spectrum analyzer settings (5725~5850MHz)	
Spectrum Analyzer function	Setting
Detector	RMS
RBW	=100kHz
VBW	300 kHz
Sweep	Auto couple
Trace	Average
Span	Encompass the 6 dB EBW
Attenuation	Auto
Sweep point	≥ 2 Span / RBW

3.4 Test procedure

Set relevant parameter according to clause 4.3.

Trace average at least 100 traces in power averaging mode.

Compute power by integrating the spectrum across the 26 dB or 6dB EBW of the signal using the instrument's band power measurement function with band limits set equal to the EBW band edges.

If measurement bandwidth of Maximum PSD is specified in 500 kHz, add $10\log(500\text{kHz}/\text{RBW})$ to the measured result, whereas RBW (< 500 KHz) is the reduced resolution bandwidth of the spectrum analyzer set during measurement. The RBW is 100 kHz. So, we will add 6.989 to the results.

3.5 Test diagram

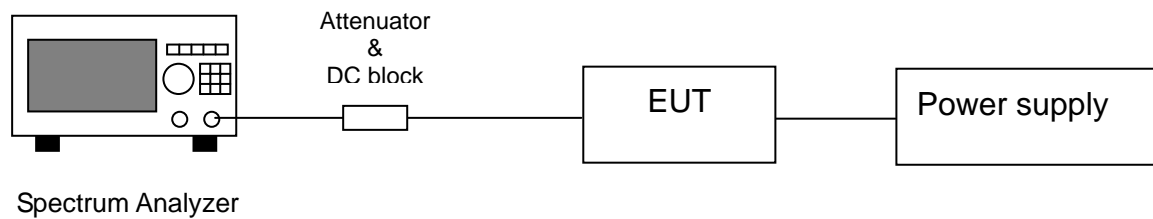

TEST REPORT

3.6 Test results

SISO

Mode	Channel	Frequency (MHz)	PSD		Result	Limit (dBm)	Margin (dB)
			(dBm)	(mW)			
802.11a Chain0	36	5180	-2.64	0.54	-2.64	11	-13.64
	44	5220	-2.32	0.59	-2.32	11	-13.32
	48	5240	-2.64	0.54	-2.64	11	-13.64
	52	5260	-2.50	0.56	-2.5	11	-13.50
	60	5300	-2.42	0.57	-2.42	11	-13.42
	64	5320	-2.81	0.52	-2.81	11	-13.81
	100	5500	-1.72	0.67	-1.72	11	-12.72
	120	5600	-0.69	0.85	-0.69	11	-11.69
	140	5700	0.26	1.06	0.26	11	-10.74
	149	5745	-2.16	0.61	-2.16	30	-32.16
	157	5785	-2.33	0.58	-2.33	30	-32.33
165	5825	-2.58	0.55	-2.58	30	-32.58	
802.11a Chain1	36	5180	0.08	1.02	0.08	11	-10.92
	44	5220	-3.09	0.49	-3.09	11	-14.09
	48	5240	-3.13	0.49	-3.13	11	-14.13
	52	5260	-2.80	0.52	-2.8	11	-13.80
	60	5300	-2.69	0.54	-2.69	11	-13.69
	64	5320	-3.23	0.48	-3.23	11	-14.23
	100	5500	-1.32	0.74	-1.32	11	-12.32
	120	5600	-0.18	0.96	-0.18	11	-11.18
	140	5700	0.28	1.07	0.28	11	-10.72
	149	5745	-2.87	0.52	-2.87	30	-32.87
	157	5785	-3.05	0.50	-3.05	30	-33.05
165	5825	-2.99	0.50	-2.99	30	-32.99	

TEST REPORT

MIMO

Mode	Channel	Frequency (MHz)	PSD (dBm)		Total PSD		MIMO	Result	Limit (dBm)	Margin (dB)
			chain0	chain1	mW	dBm	Correction			
802.11ac (VHT20)	36	5180	-3.01	-3.24	0.97	-0.11	3.01	2.90	11	-8.10
	44	5220	-2.98	-3.35	0.97	-0.15	3.01	2.86	11	-8.14
	48	5240	-2.92	-3.55	0.95	-0.21	3.01	2.80	11	-8.20
	52	5260	-3.11	-3.04	0.99	-0.06	3.01	2.95	11	-8.05
	60	5300	-3.10	-3.16	0.97	-0.12	3.01	2.89	11	-8.11
	64	5320	-3.64	-3.42	0.89	-0.52	3.01	2.49	11	-8.51
	100	5500	-2.07	-1.45	1.34	1.26	3.01	4.27	11	-6.73
	120	5600	-1.06	-0.50	1.67	2.24	3.01	5.25	11	-5.75
	140	5700	-0.25	-0.12	1.92	2.83	3.01	5.84	11	-5.16
	149	5745	-2.96	-3.28	0.98	-0.11	3.01	2.90	30	-27.10
	157	5785	-3.00	-3.92	0.91	-0.43	3.01	2.58	30	-27.42
165	5825	-3.02	-3.23	0.97	-0.11	3.01	2.90	30	-27.10	
802.11ac (VHT40)	38	5190	-7.36	-8.08	0.34	-4.69	3.01	-1.68	11	-12.68
	46	5230	-7.07	-7.53	0.37	-4.28	3.01	-1.27	11	-12.27
	54	5270	-6.99	-7.04	0.40	-4.00	3.01	-0.99	11	-11.99
	62	5310	-7.36	-7.18	0.38	-4.26	3.01	-1.25	11	-12.25
	102	5510	-5.45	-5.38	0.57	-2.40	3.01	0.61	11	-10.39
	118	5590	-4.11	-4.14	0.77	-1.11	3.01	1.90	11	-9.10
	134	5670	-4.22	-4.43	0.74	-1.31	3.01	1.70	11	-9.30
	151	5755	-5.61	-6.15	0.52	-2.86	3.01	0.15	30	-29.85
	159	5795	-6.64	-6.59	0.44	-3.60	3.01	-0.59	30	-30.59
802.11ac (VHT80)	42	5210	-13.84	-14.24	0.08	-11.03	3.01	-8.01	11	-19.01
	58	5290	-13.57	-13.69	0.09	-10.62	3.01	-7.61	11	-18.61
	106	5530	-12.53	-12.38	0.11	-9.44	3.01	-6.43	11	-17.43
	122	5610	-10.99	-11.35	0.15	-8.16	3.01	-5.15	11	-16.15
	155	5775	-12.62	-11.90	0.12	-9.23	3.01	-6.22	30	-36.22

Note: MIMO Correction: $10\log(Nant)$

RBW Correction: $10\log(500kHz/1MHz)$ or $10\log(500kHz/100kHz)$

Note: The values of 802.11a Chain1 have modified with Reference level Offset($37.49\text{ dB}=30.5(\text{cable loss}) + 10\text{Log}(500/100)$).

Chain0 : Power Spectral Density @ 802.11a Mode Ch36



Chain0 : Power Spectral Density @ 802.11a Mode Ch44

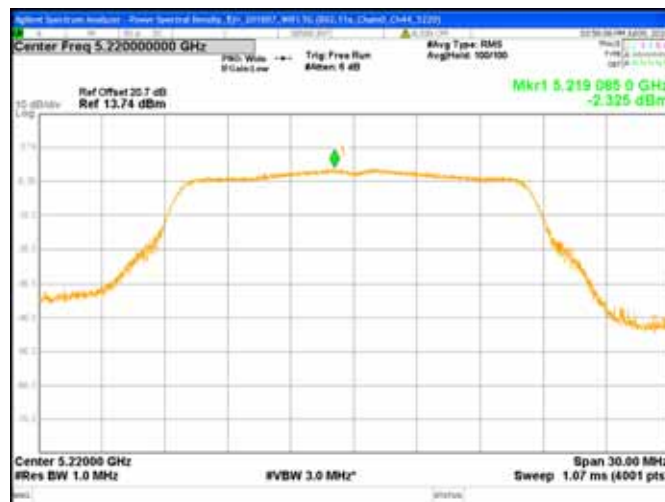

Chain0 : Power Spectral Density @ 802.11a Mode Ch48

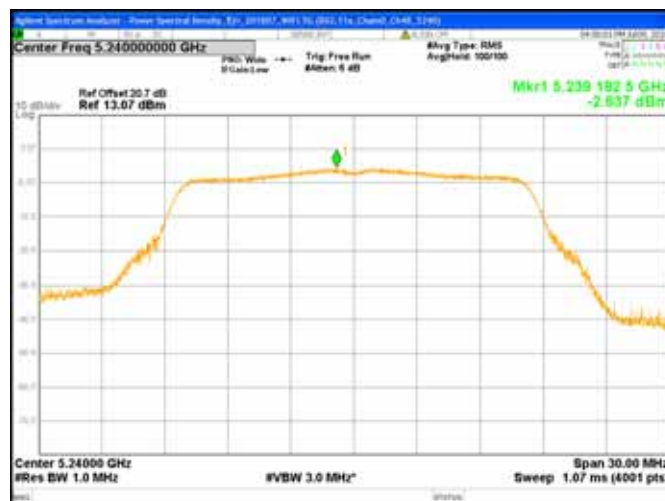

Chain0 : Power Spectral Density @ 802.11a Mode Ch52

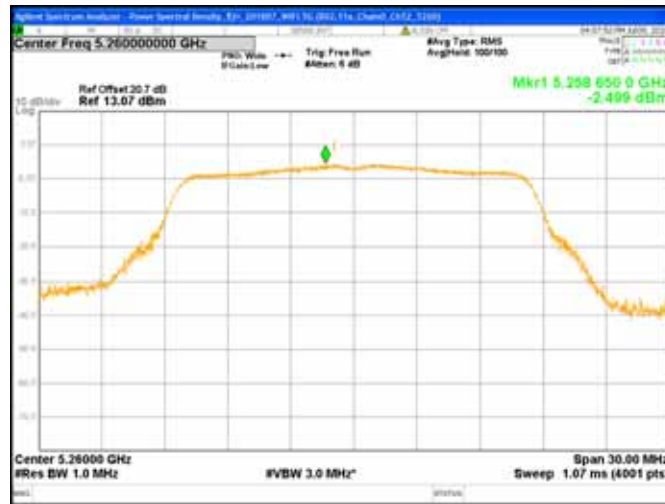

Chain0 : Power Spectral Density @ 802.11a Mode Ch60

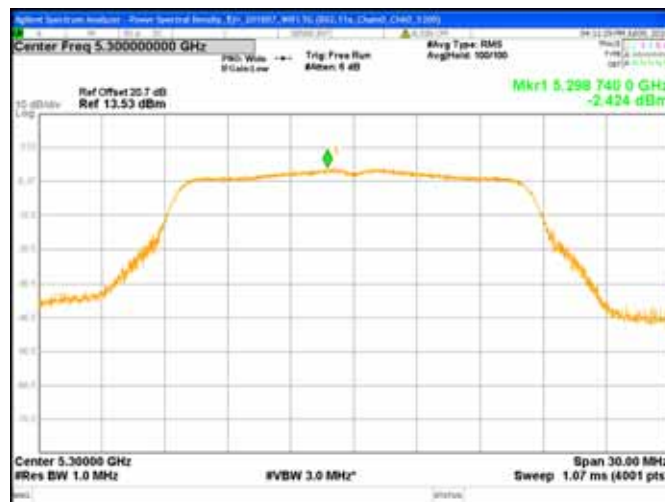

Chain0 : Power Spectral Density @ 802.11a Mode Ch64

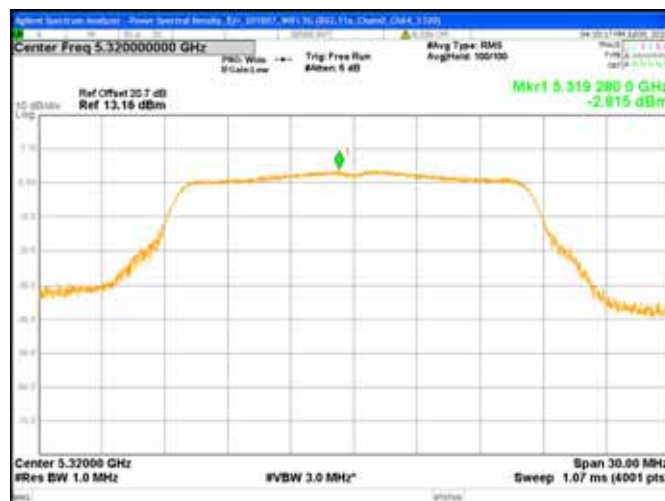

Chain0 : Power Spectral Density @ 802.11a Mode Ch100

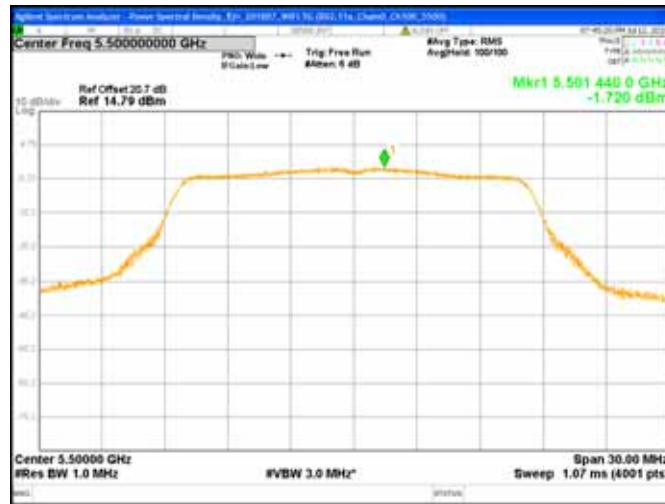

Chain0 : Power Spectral Density @ 802.11a Mode Ch120

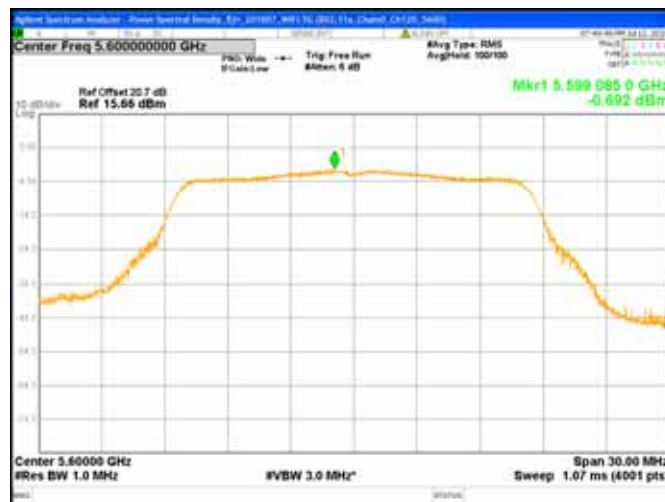

Chain0 : Power Spectral Density @ 802.11a Mode Ch140

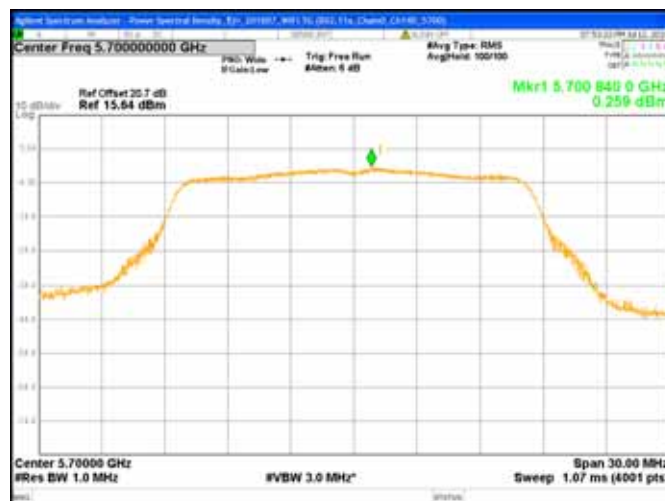

Chain0 : Power Spectral Density @ 802.11a Mode Ch149

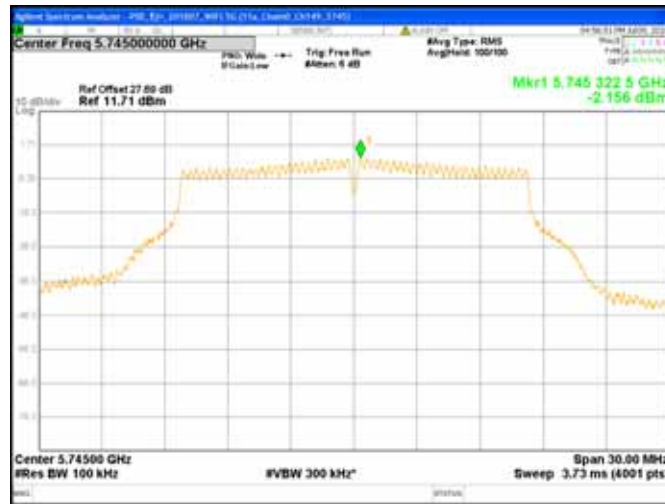

Chain0 : Power Spectral Density @ 802.11a Mode Ch157

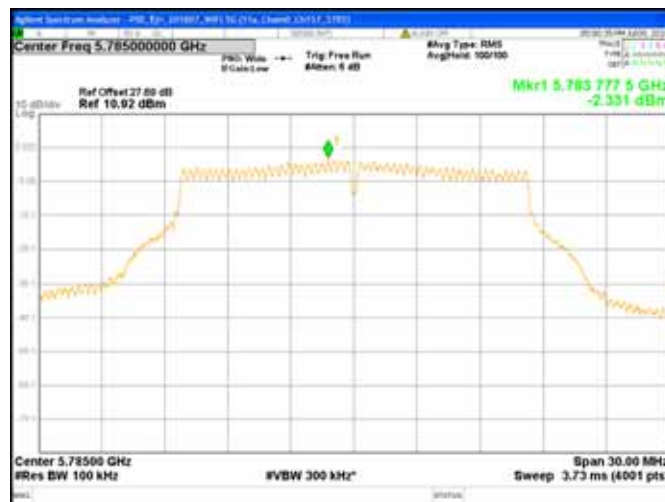

Chain0 : Power Spectral Density @ 802.11a Mode Ch165

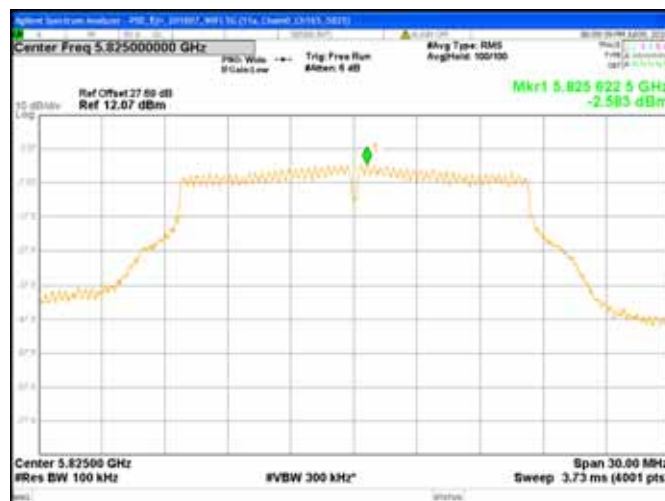

Chain1 : Power Spectral Density @ 802.11a Mode Ch36

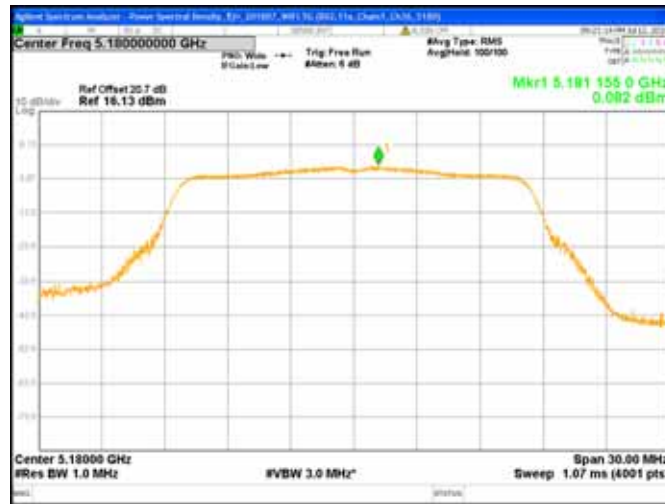

Chain1 : Power Spectral Density @ 802.11a Mode Ch44

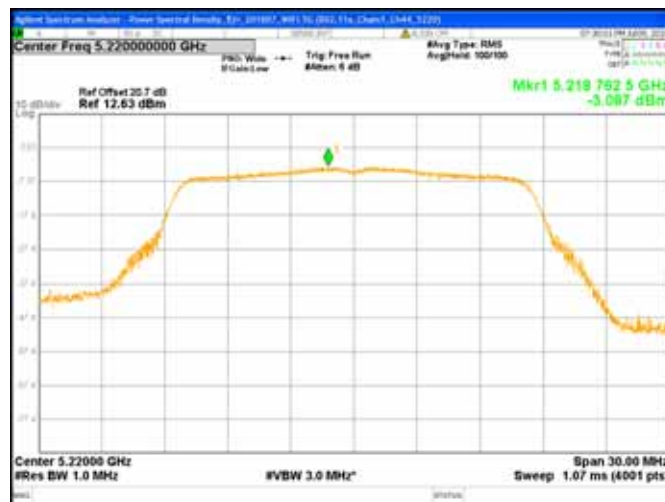

Chain1 : Power Spectral Density @ 802.11a Mode Ch48

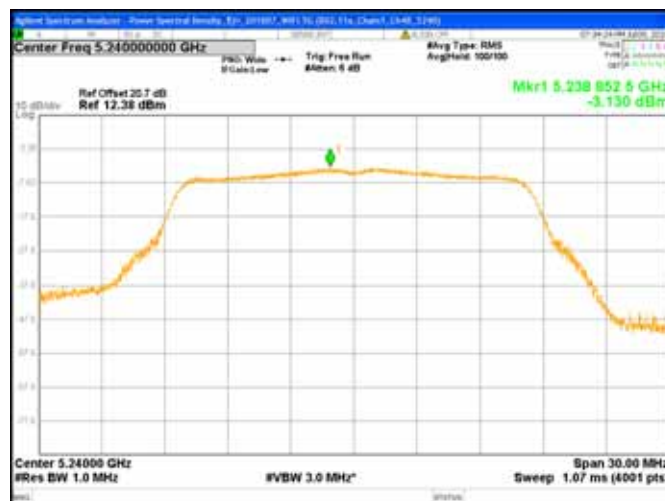

Chain1 : Power Spectral Density @ 802.11a Mode Ch52

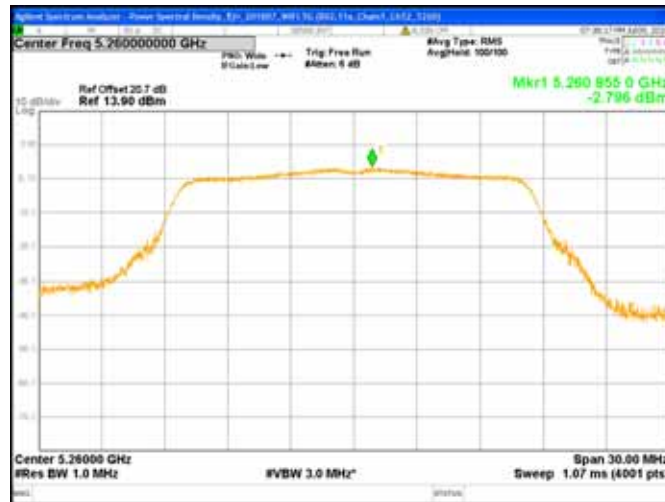

Chain1 : Power Spectral Density @ 802.11a Mode Ch60

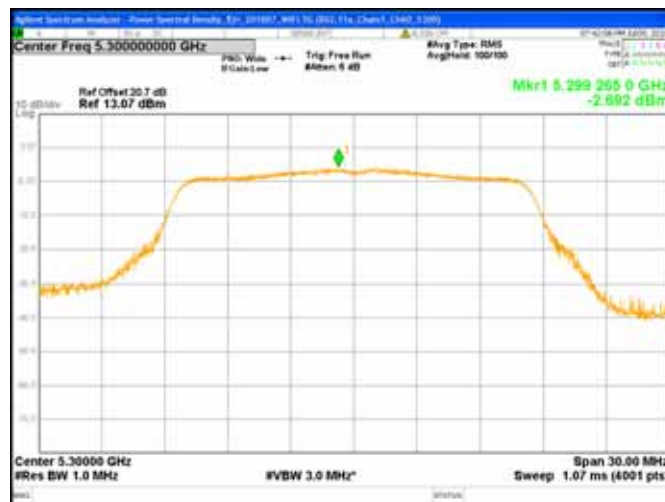

Chain1 : Power Spectral Density @ 802.11a Mode Ch64

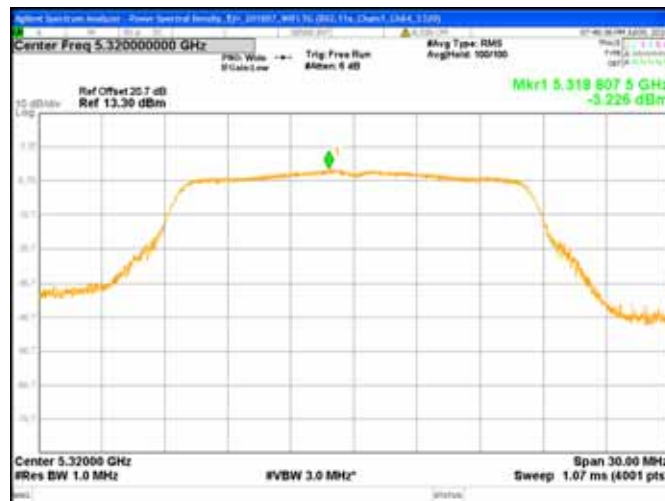

Chain1 : Power Spectral Density @ 802.11a Mode Ch100

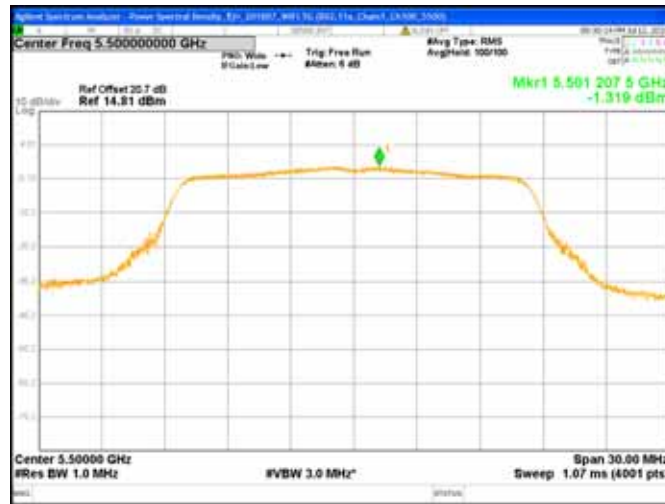

Chain1 : Power Spectral Density @ 802.11a Mode Ch120

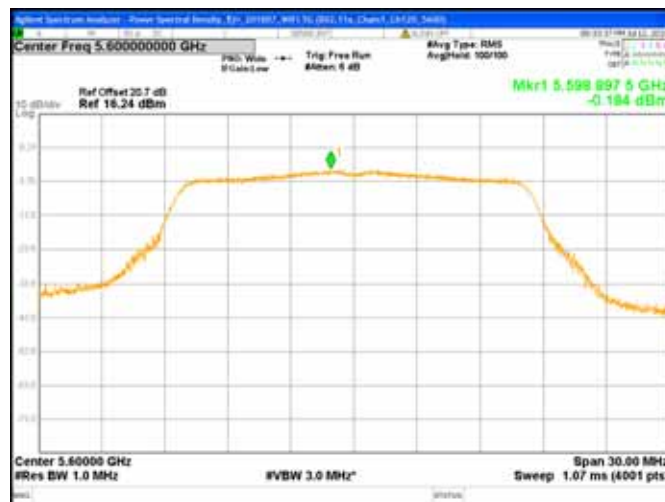

Chain1 : Power Spectral Density @ 802.11a Mode Ch140

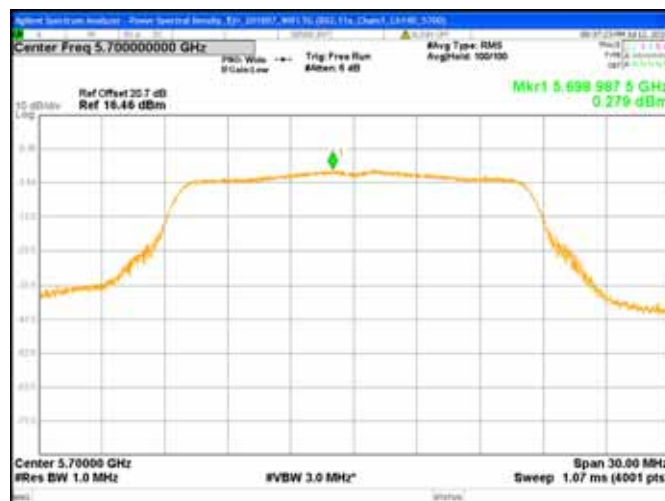

Chain1 : Power Spectral Density @ 802.11a Mode Ch149

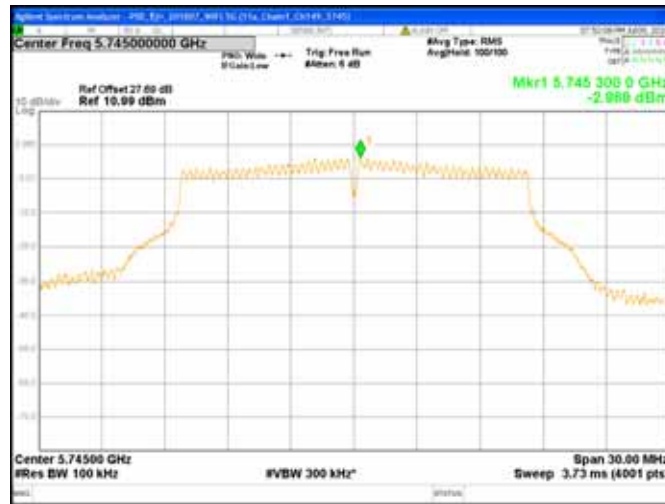

Chain1 : Power Spectral Density @ 802.11a Mode Ch157

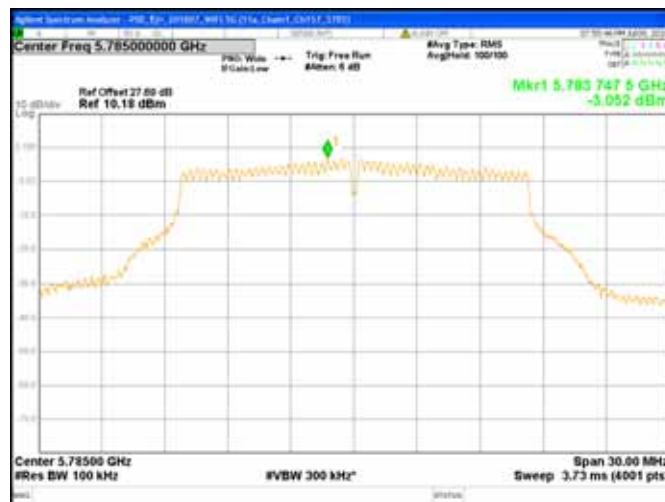

Chain1 : Power Spectral Density @ 802.11a Mode Ch165

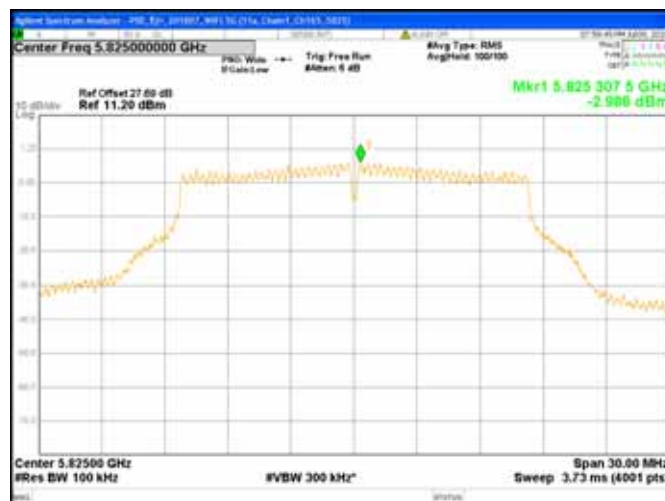

Chain0 : Power Spectral Density @ 802.11ac(VHT20) Mode Ch36

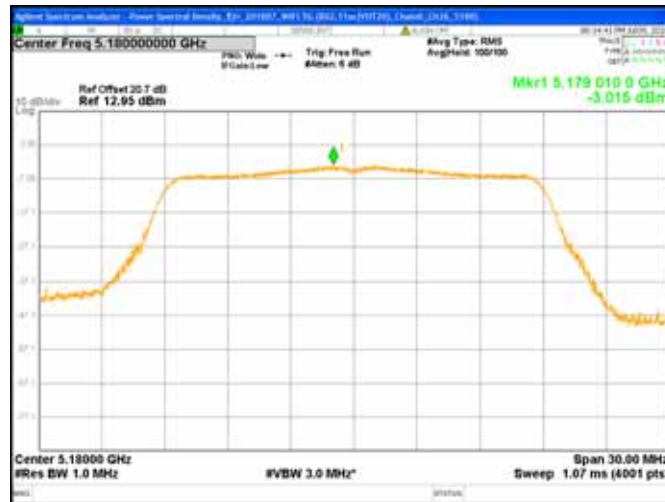

Chain0 : Power Spectral Density @ 802.11ac(VHT20) Mode Ch44

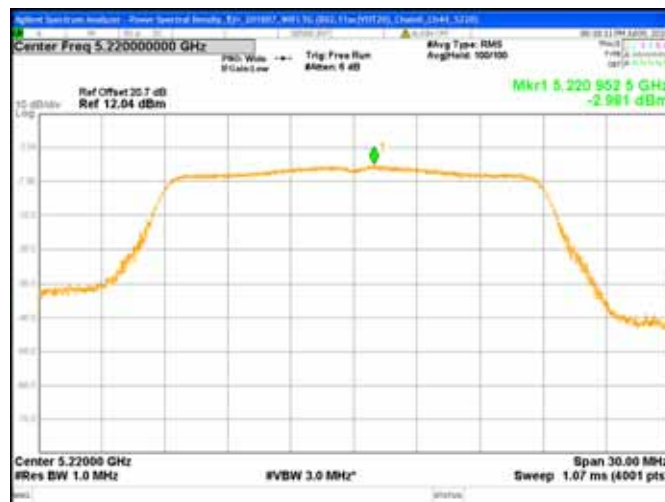

Chain0 : Power Spectral Density @ 802.11ac(VHT20) Mode Ch48

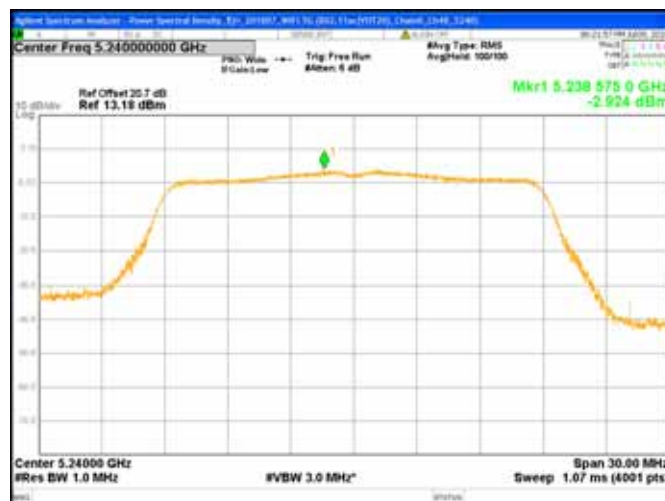

Chain0 : Power Spectral Density @ 802.11ac(VHT20) Mode Ch52

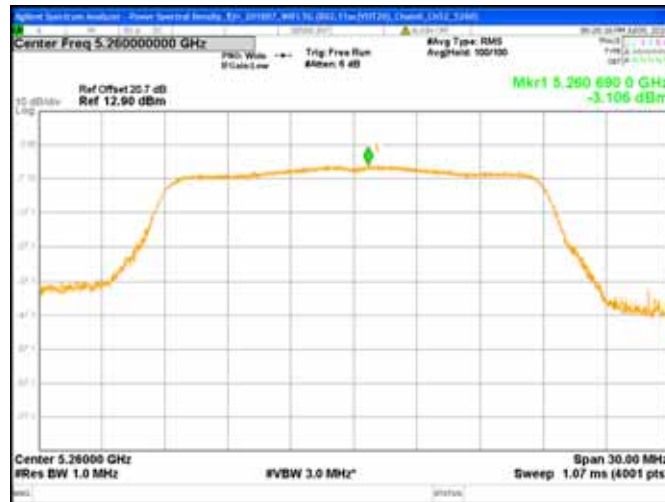

Chain0 : Power Spectral Density @ 802.11ac(VHT20) Mode Ch60

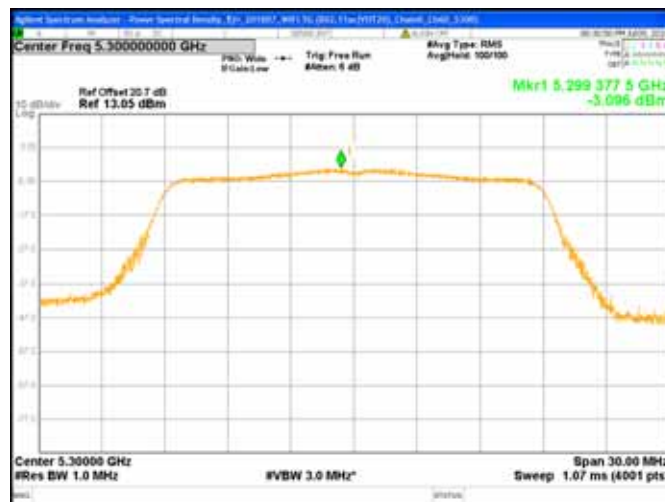

Chain0 : Power Spectral Density @ 802.11ac(VHT20) Mode Ch64

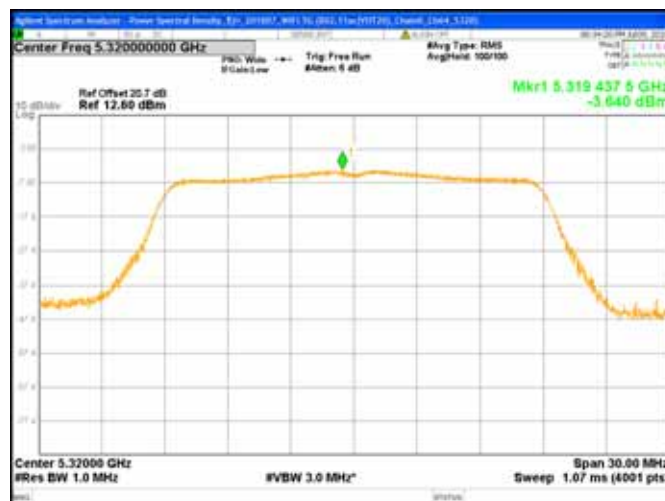

Chain0 : Power Spectral Density @ 802.11ac(VHT20) Mode Ch100

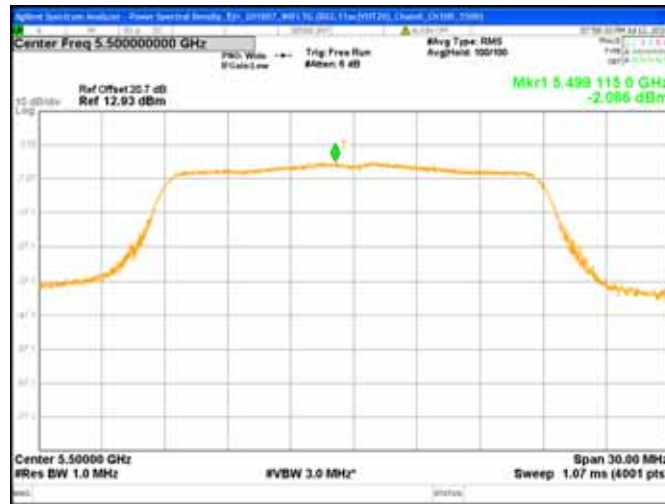

Chain0 : Power Spectral Density @ 802.11ac(VHT20) Mode Ch120

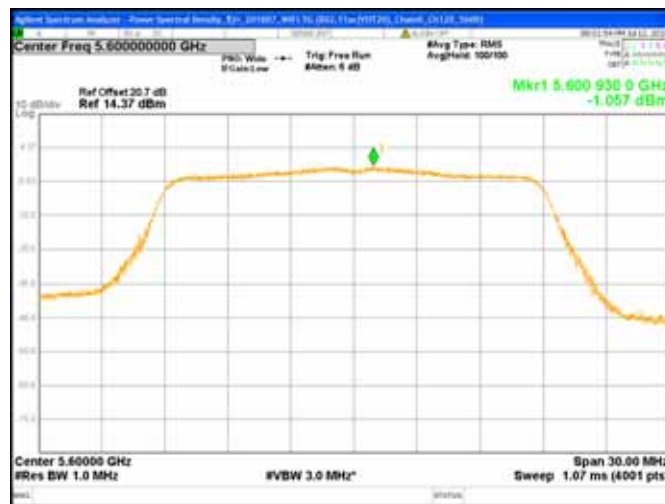

Chain0 : Power Spectral Density @ 802.11ac(VHT20) Mode Ch140

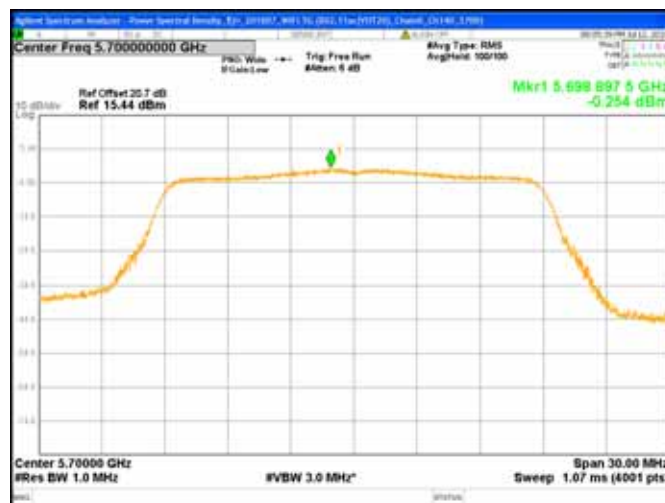

Chain0 : Power Spectral Density @ 802.11ac(VHT20) Mode Ch149

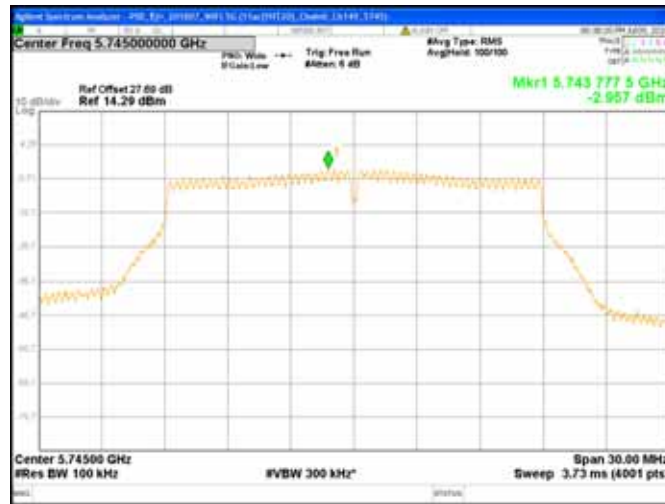

Chain0 : Power Spectral Density @ 802.11ac(VHT20) Mode Ch157

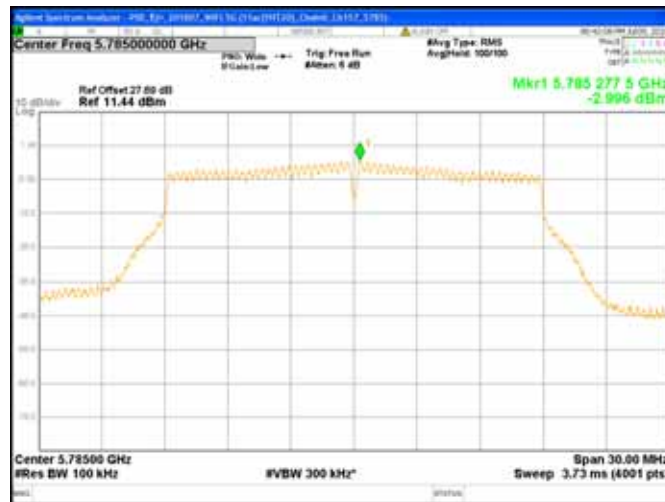

Chain0 : Power Spectral Density @ 802.11ac(VHT20) Mode Ch165

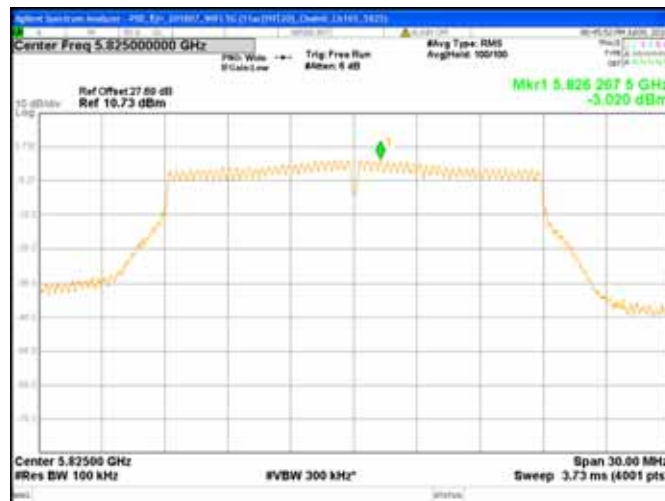

Chain1 : Power Spectral Density @ 802.11ac(VHT20) Mode Ch36



Chain1 : Power Spectral Density @ 802.11ac(VHT20) Mode Ch44

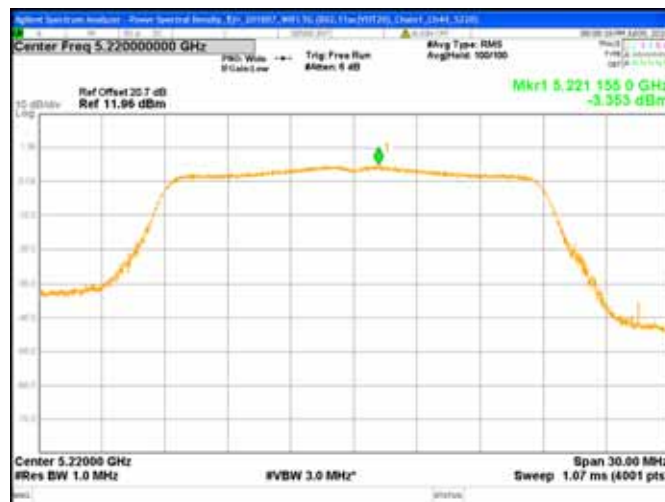

Chain1 : Power Spectral Density @ 802.11ac(VHT20) Mode Ch48

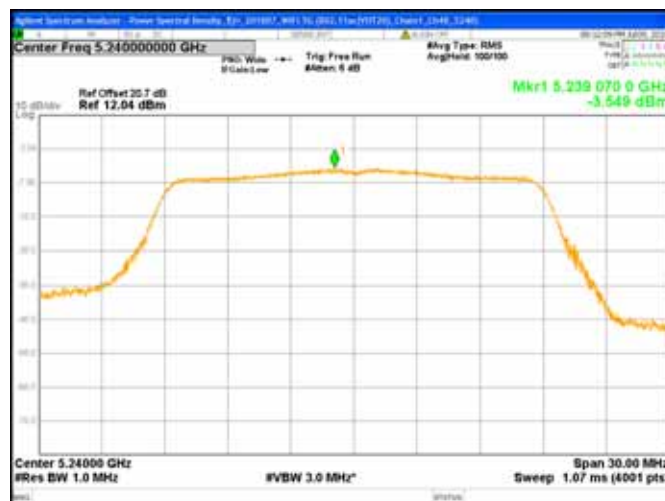

Chain1 : Power Spectral Density @ 802.11ac(VHT20) Mode Ch52

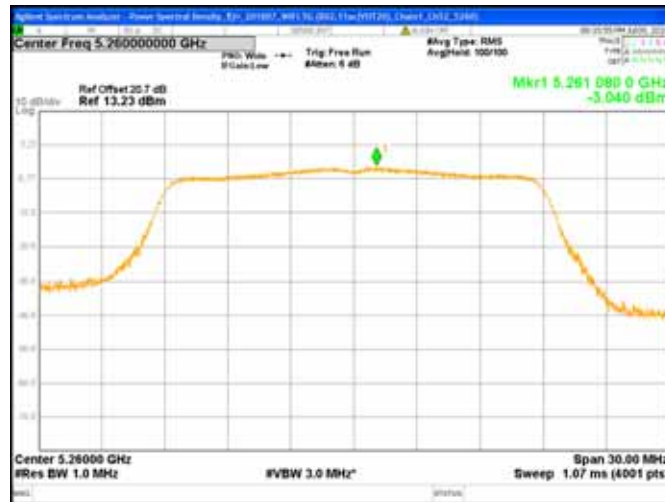

Chain1 : Power Spectral Density @ 802.11ac(VHT20) Mode Ch60

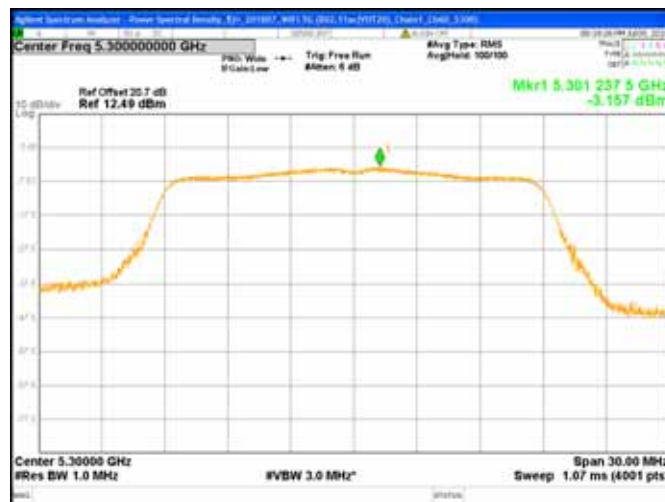

Chain1 : Power Spectral Density @ 802.11ac(VHT20) Mode Ch64

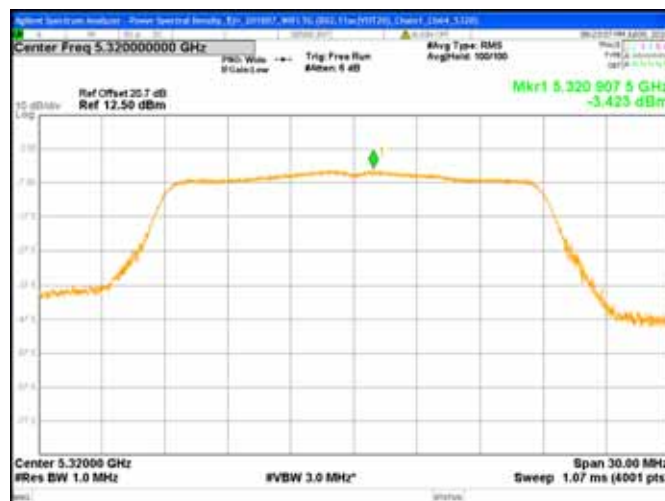

Chain1 : Power Spectral Density @ 802.11ac(VHT20) Mode Ch100

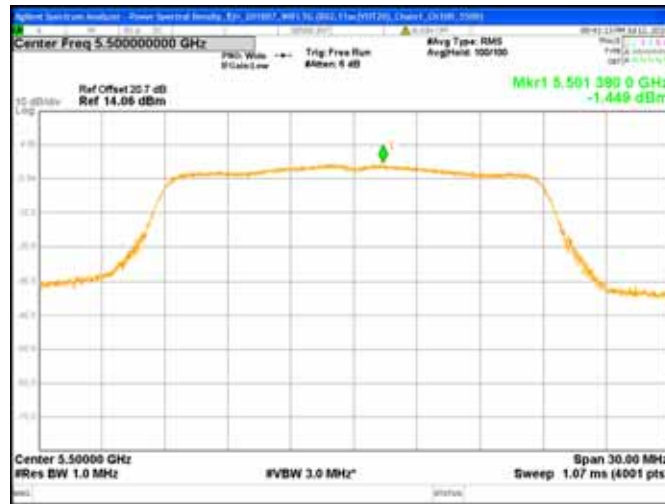

Chain1 : Power Spectral Density @ 802.11ac(VHT20) Mode Ch120

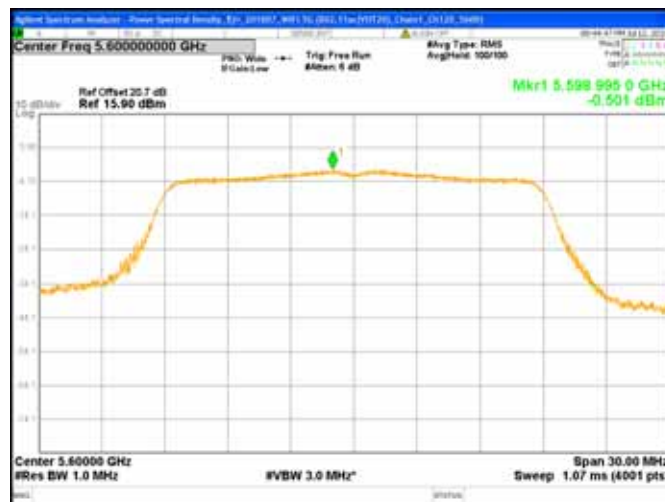

Chain1 : Power Spectral Density @ 802.11ac(VHT20) Mode Ch140

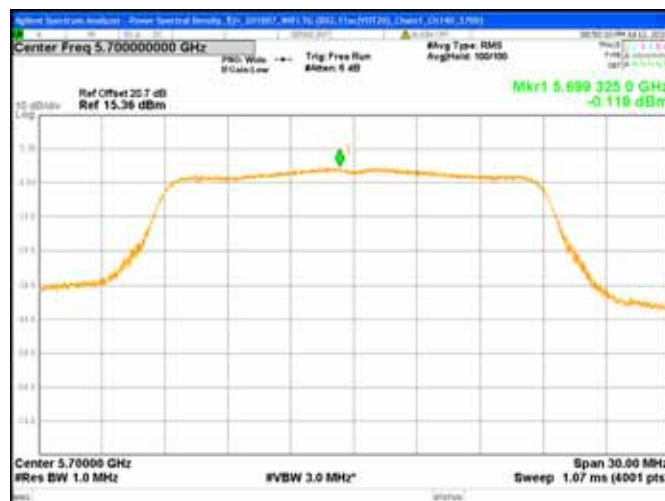

Chain1 : Power Spectral Density @ 802.11ac(VHT20) Mode Ch149

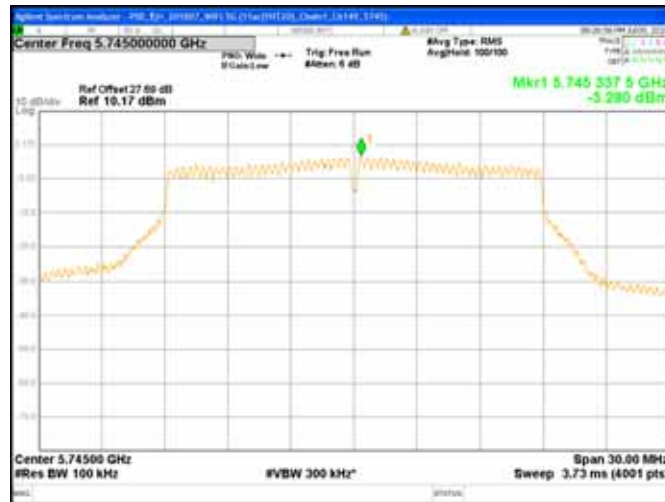

Chain1 : Power Spectral Density @ 802.11ac(VHT20) Mode Ch157

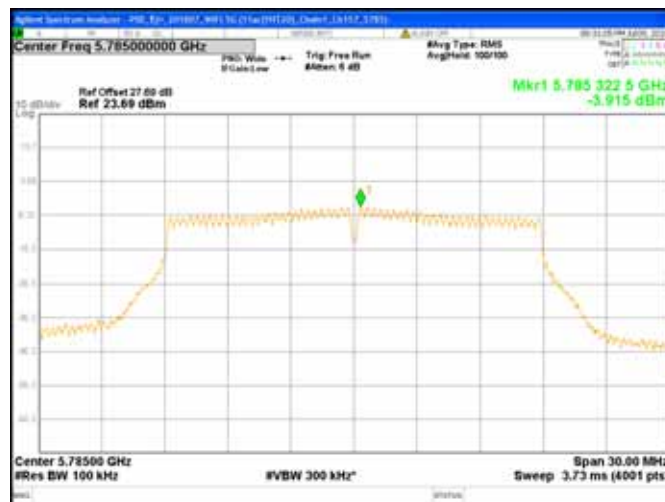

Chain1 : Power Spectral Density @ 802.11ac(VHT20) Mode Ch165

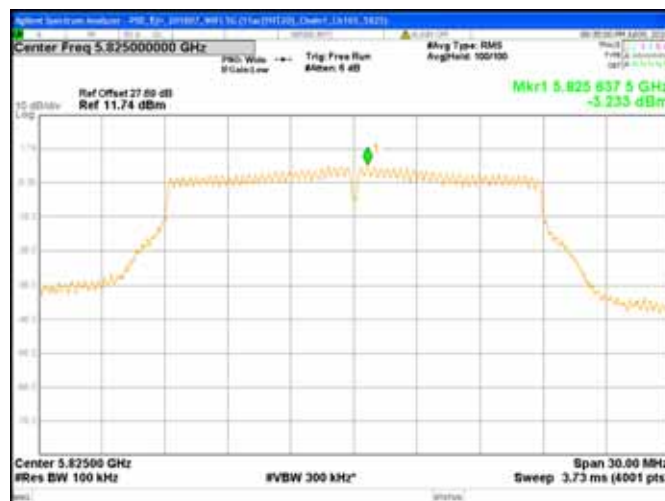

Chain0 : Power Spectral Density @ 802.11ac(VHT40) Mode Ch38



Chain0 : Power Spectral Density @ 802.11ac(VHT40) Mode Ch46

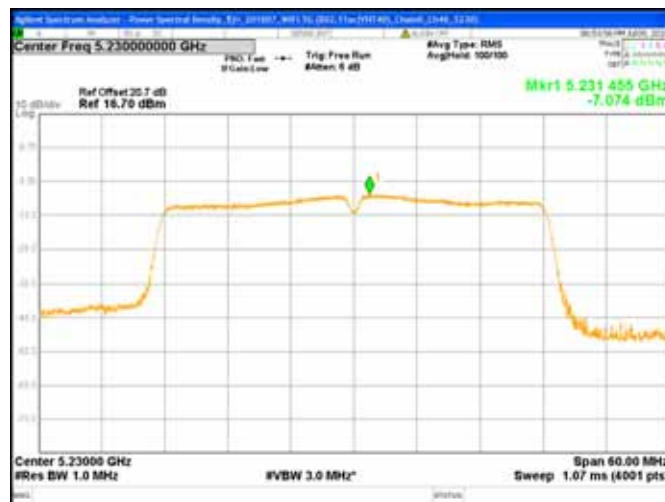

Chain0 : Power Spectral Density @ 802.11ac(VHT40) Mode Ch54

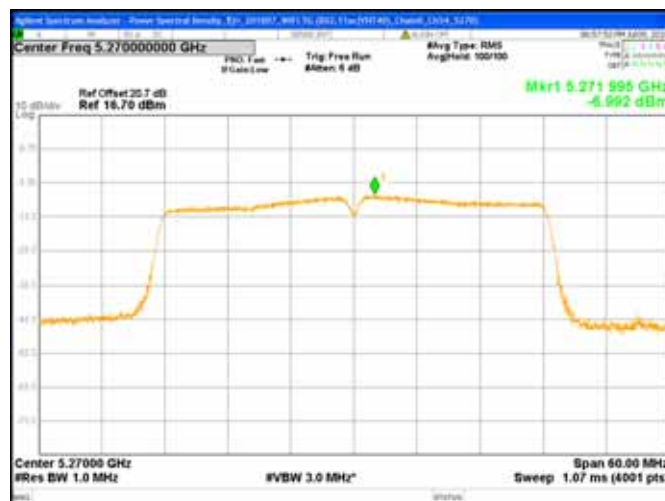

Chain0 : Power Spectral Density @ 802.11ac(VHT40) Mode Ch62

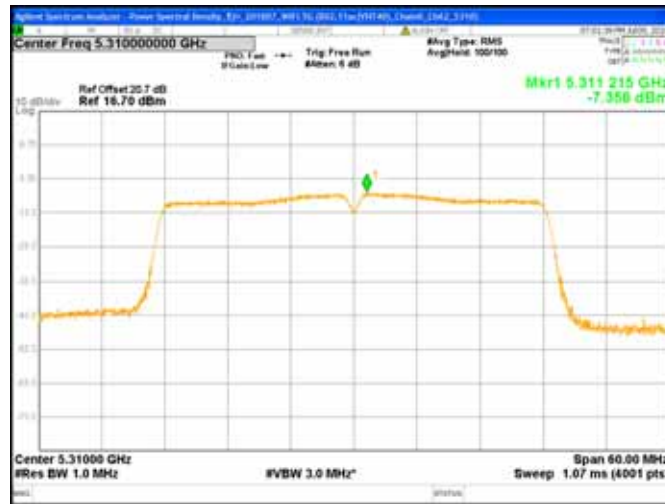

Chain0 : Power Spectral Density @ 802.11ac(VHT40) Mode Ch102

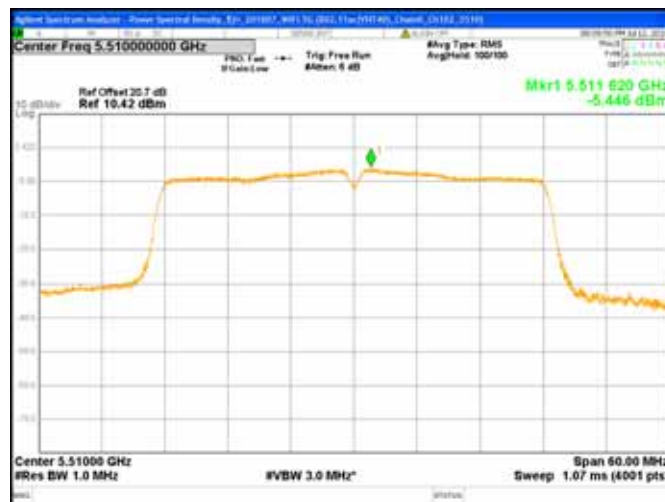

Chain0 : Power Spectral Density @ 802.11ac(VHT40) Mode Ch118

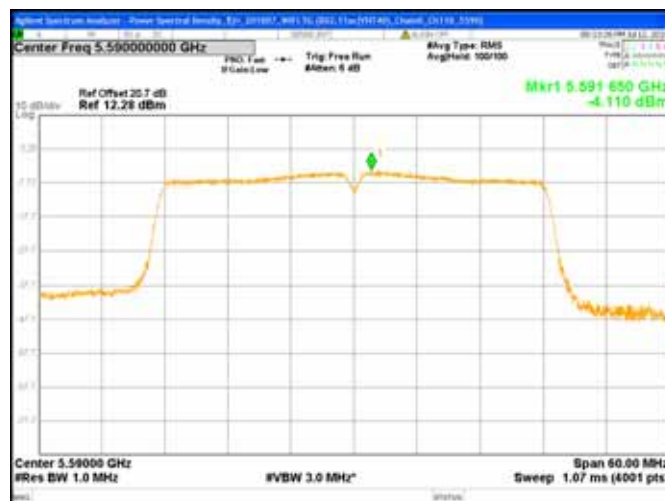

Chain0 : Power Spectral Density @ 802.11ac(VHT40) Mode Ch134



Chain0 : Power Spectral Density @ 802.11ac(VHT40) Mode Ch151

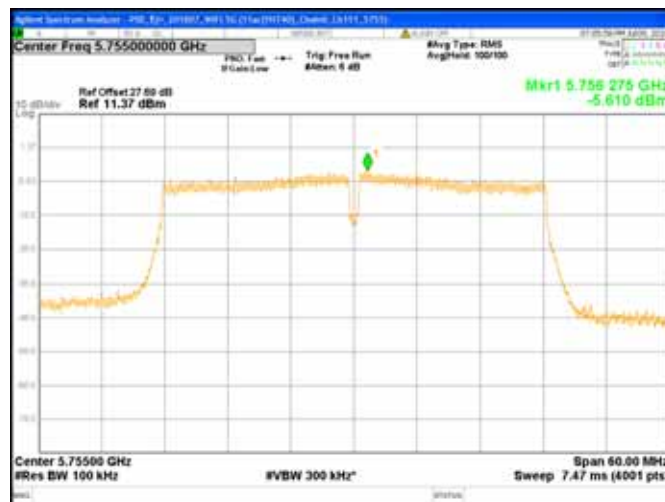

Chain0 : Power Spectral Density @ 802.11ac(VHT40) Mode Ch159

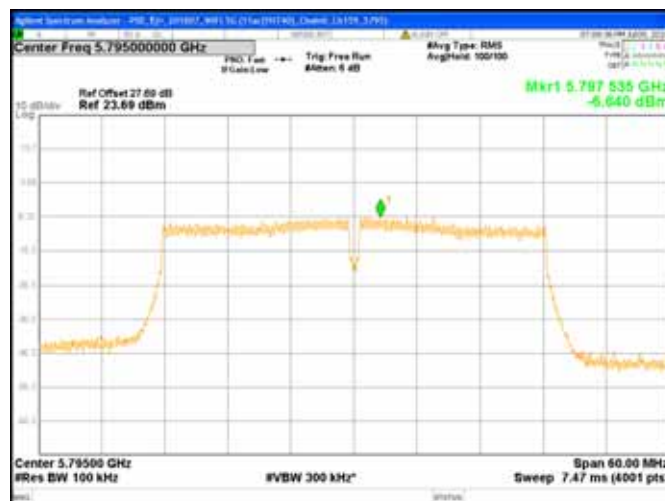

Chain1 : Power Spectral Density @ 802.11ac(VHT40) Mode Ch38

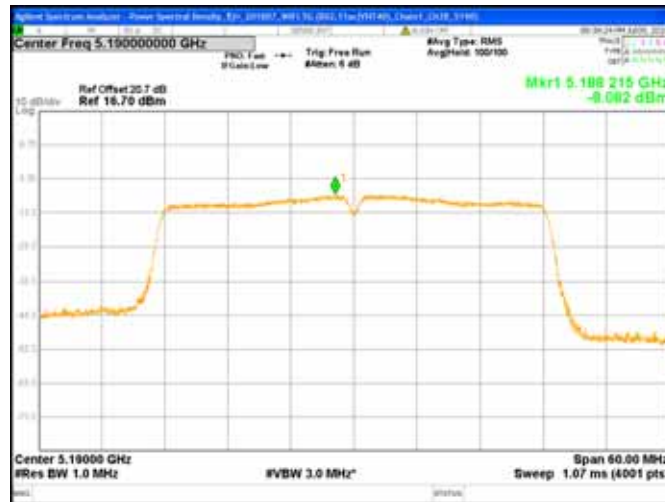

Chain1 : Power Spectral Density @ 802.11ac(VHT40) Mode Ch46

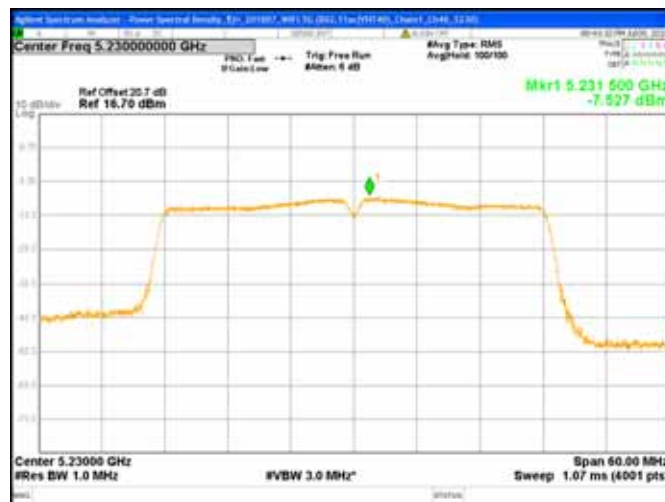

Chain1 : Power Spectral Density @ 802.11ac(VHT40) Mode Ch54

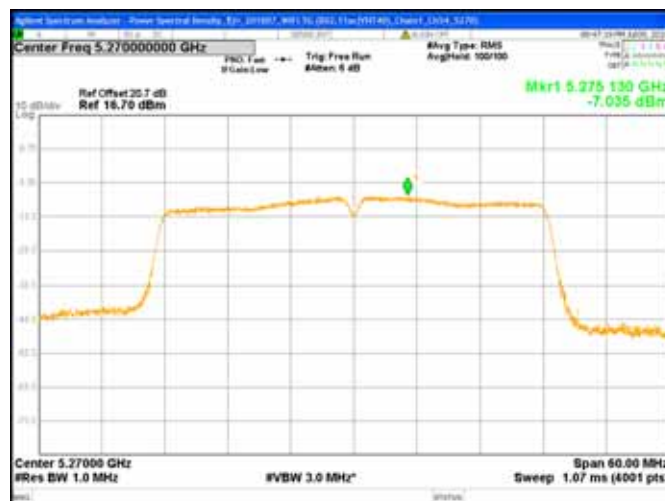

Chain1 : Power Spectral Density @ 802.11ac(VHT40) Mode Ch62

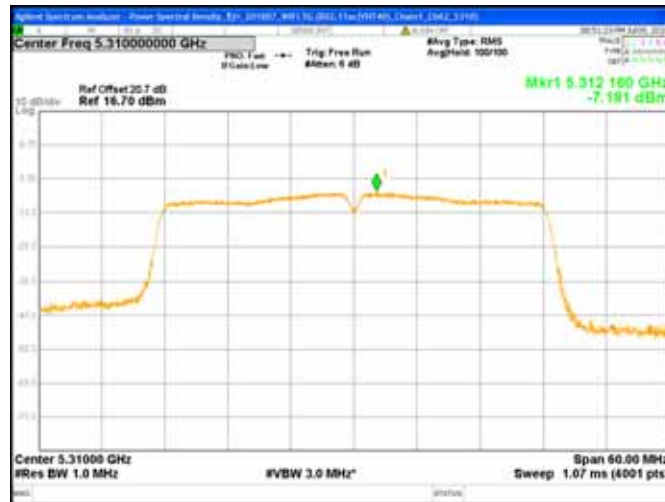

Chain1 : Power Spectral Density @ 802.11ac(VHT40) Mode Ch102

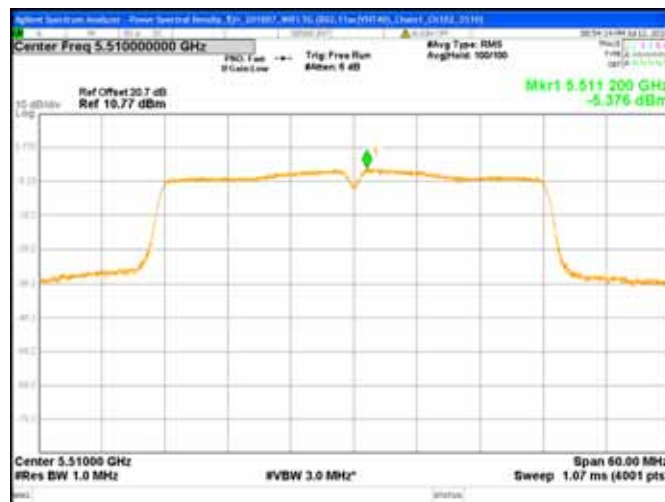

Chain1 : Power Spectral Density @ 802.11ac(VHT40) Mode Ch118

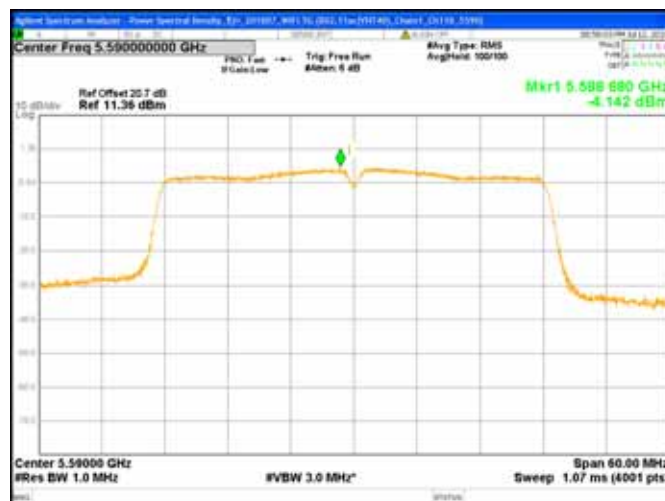

Chain1 : Power Spectral Density @ 802.11ac(VHT40) Mode Ch134



Chain1 : Power Spectral Density @ 802.11ac(VHT40) Mode Ch151

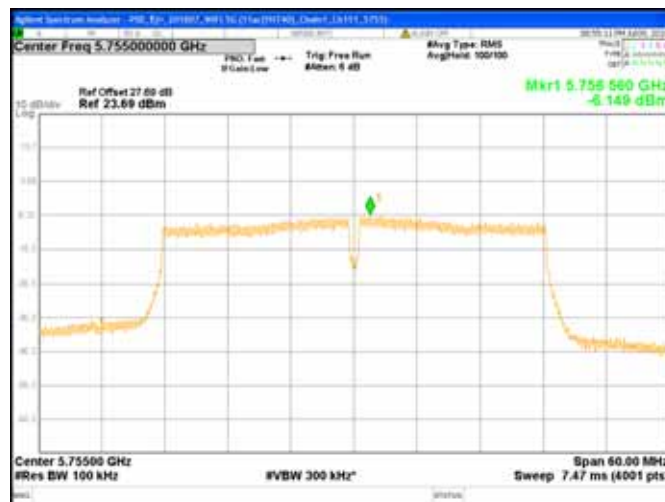

Chain1 : Power Spectral Density @ 802.11ac(VHT40) Mode Ch159

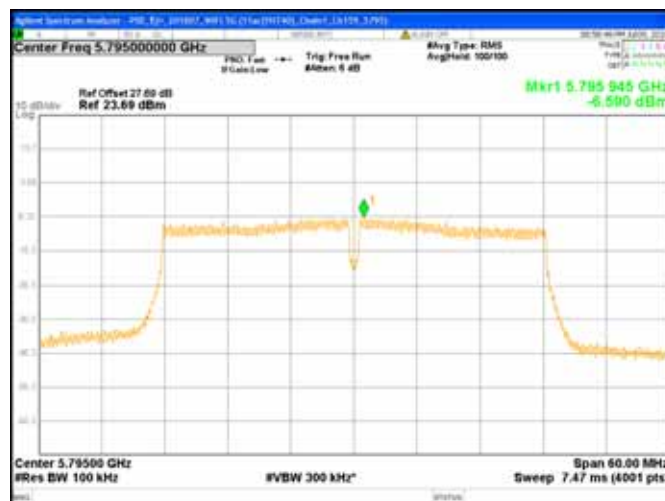

Chain0 : Power Spectral Density @ 802.11ac(VHT80) Mode Ch42

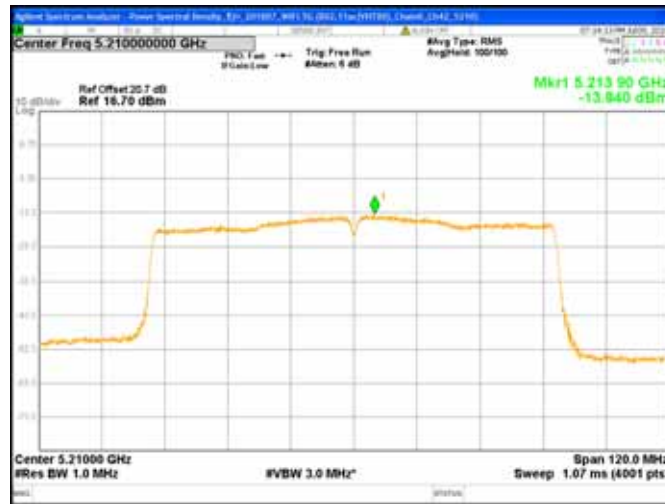

Chain0 : Power Spectral Density @ 802.11ac(VHT80) Mode Ch58

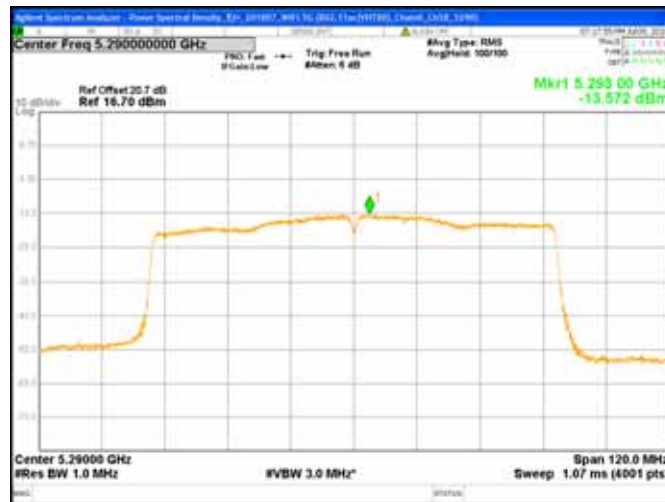

Chain0 : Power Spectral Density @ 802.11ac(VHT80) Mode Ch106

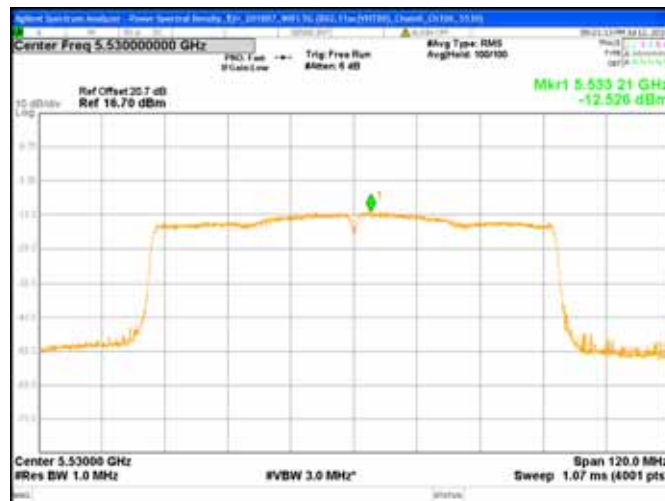

Chain0 : Power Spectral Density @ 802.11ac(VHT80) Mode Ch122

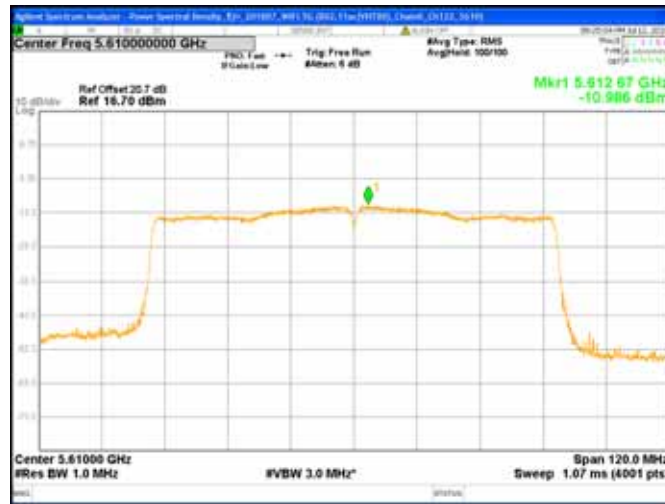

Chain0 : Power Spectral Density @ 802.11ac(VHT80) Mode Ch155

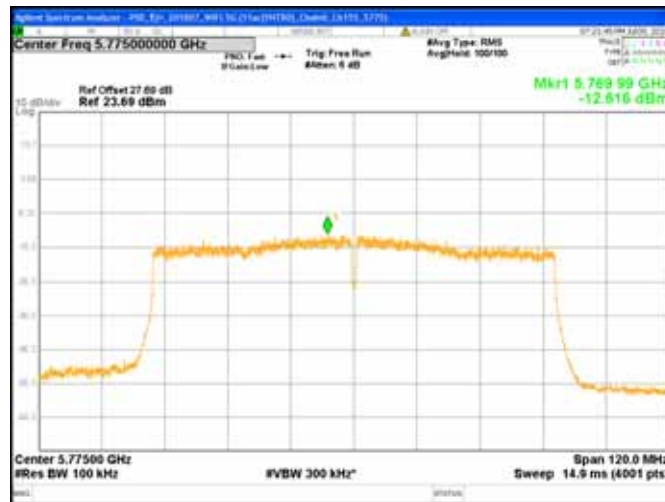

Chain1 : Power Spectral Density @ 802.11ac(VHT80) Mode Ch42

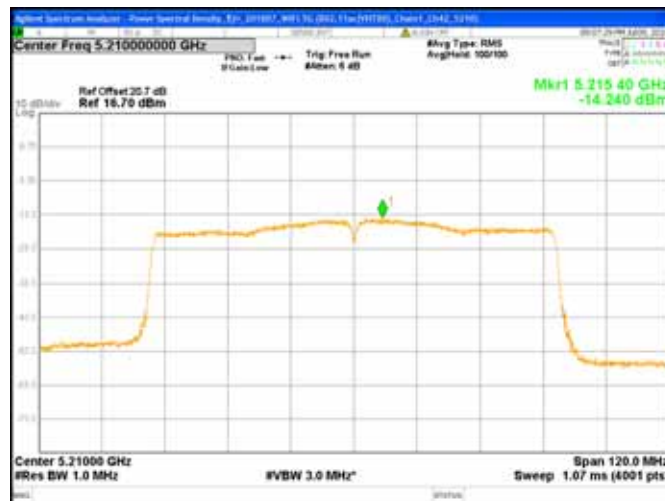

Chain1 : Power Spectral Density @ 802.11ac(VHT80) Mode Ch58

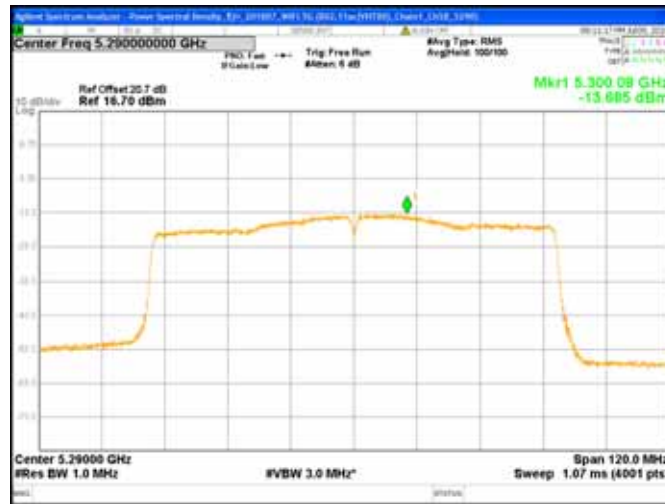

Chain1 : Power Spectral Density @ 802.11ac(VHT80) Mode Ch106

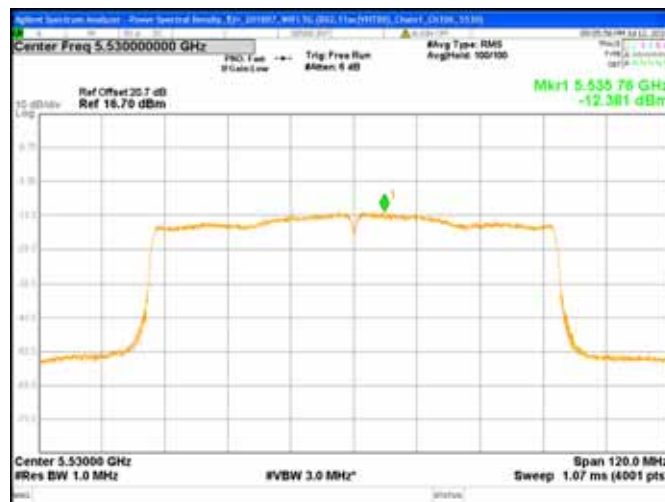

Chain1 : Power Spectral Density @ 802.11ac(VHT80) Mode Ch122

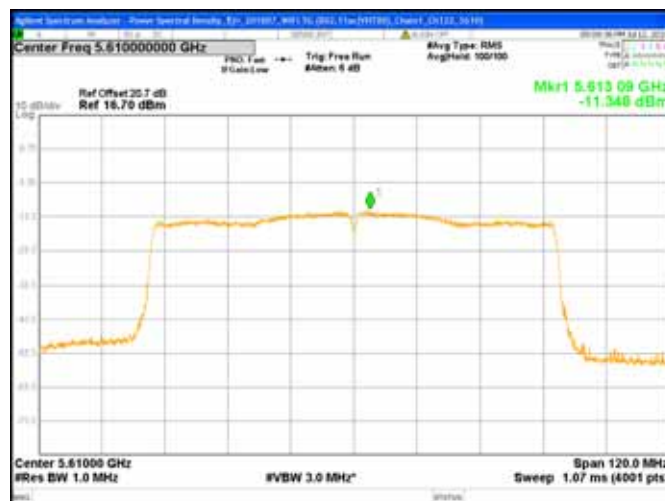

Chain1 : Power Spectral Density @ 802.11ac(VHT80) Mode Ch155



4. Minimum Bandwidth

4.1 Operating environment

Temperature:	25	
Relative Humidity:	50	%
Atmospheric Pressure	1008	hPa
Requirement & Test method	15.407(a)(5) 15.407(e) KDB 789033 D02 v01r02	

4.2 Limit for minimum emission bandwidth.

Within the 5.15-5.25 GHz, the 26 dB bandwidth is for reporting purpose only.

Within the 5.725-5.85 GHz, the minimum 6 dB bandwidth of U-NII devices shall be at least 500 kHz..

4.3 Measuring instrument setting

For 5.15-5.25 GHz

Spectrum analyzer settings	
Spectrum Analyzer function	Setting
Detector	Peak
RBW	Approximately 1% of the EBW
VBW	> RBW
Trace mode	Max hold

For 5.725-5.85 GHz

Spectrum analyzer settings	
Spectrum Analyzer function	Setting
Detector	Peak
RBW	100kHz
VBW	3 x RBW
Sweep	Auto couple
Trace mode	Max hold

4.4 Test procedure

1. The transmitter output was connected to the spectrum analyzer.
2. Test was performed in accordance with section C of KDB 789033 D02 v01r02.
3. For the 5.725-5.85 GHz, measure the maximum width of the emission that is constrained by the frequencies associated with the two outermost amplitude points (upper and lower frequencies) that are attenuated by 6 dB relative to the maximum level measured in the fundamental emission.
4. For the 5.15-5.25 GHz and 5.725-5.85 GHz, measure the maximum width of the emission that is 26 dB down from the maximum of the emission.

4.5 Test diagram

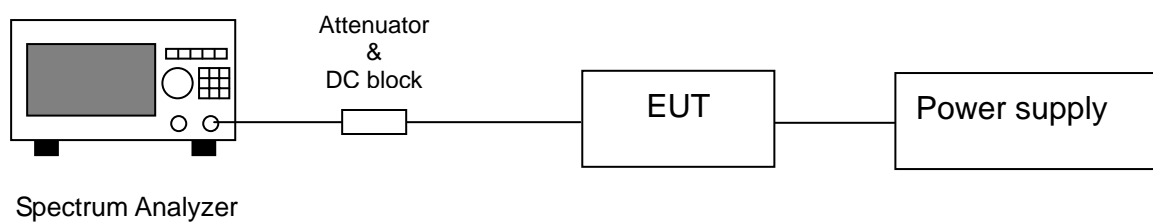

4.6 Test results

SISO

Mode	Channel	Frequency (MHz)	6dB Bandwidth (MHz)	26dB Bandwidth (MHz)	Limit (MHz)	Result
802.11a Chain0	36	5180		22.12	N/A	Pass
	44	5220		21.99		Pass
	48	5240		21.78		Pass
	52	5260		21.87		Pass
	60	5300		21.98		Pass
	64	5320		26.00		Pass
	100	5500		21.99		Pass
	120	5600		21.98		Pass
	140	5700		22.20		Pass
	149	5745	16.33		>0.5	Pass
	157	5785	16.36			Pass
	165	5825	16.33			Pass
802.11a Chain1	36	5180		21.97	N/A	Pass
	44	5220		21.93		Pass
	48	5240		22.03		Pass
	52	5260		25.70		Pass
	60	5300		25.30		Pass
	64	5320		25.37		Pass
	100	5500		25.69		Pass
	120	5600		25.68		Pass
	140	5700		21.98		Pass
	149	5745	16.32		>0.5	Pass
	157	5785	16.31			Pass
	165	5825	16.33			Pass

TEST REPORT

SISO

Mode	Channel	Frequency (MHz)	6dB Bandwidth (MHz)	26dB Bandwidth (MHz)	Limit (MHz)	Result
802.11ac (VHT20) Chain0	36	5180		21.88	N/A	Pass
	44	5220		21.98		Pass
	48	5240		22.34		Pass
	52	5260		25.20		Pass
	60	5300		21.91		Pass
	64	5320		23.57		Pass
	100	5500		22.14		Pass
	120	5600		22.01		Pass
	140	5700		22.37		Pass
	149	5745	17.55		>0.5	Pass
	157	5785	17.55			Pass
	165	5825	17.55			Pass
802.11ac (VHT20) Chain1	36	5180		22.23	N/A	Pass
	44	5220		21.91		Pass
	48	5240		22.16		Pass
	52	5260		22.11		Pass
	60	5300		23.49		Pass
	64	5320		25.04		Pass
	100	5500		22.08		Pass
	120	5600		22.06		Pass
	140	5700		23.10		Pass
	149	5745	17.56		>0.5	Pass
	157	5785	17.58			Pass
	165	5825	17.59			Pass
802.11ac (VHT40) Chain0	38	5190		41.97	N/A	Pass
	46	5230		42.82		Pass
	54	5270		41.23		Pass
	62	5310		40.91		Pass
	102	5510		40.71		Pass
	118	5590		40.69		Pass
	134	5670		40.67		Pass
	151	5755	36.29		>0.5	Pass
	159	5795	35.94			Pass

TEST REPORT

SISO

Mode	Channel	Frequency (MHz)	6dB Bandwidth (MHz)	26dB Bandwidth (MHz)	Limit (MHz)	Result
802.11ac (VHT40) Chain1	38	5190		40.65	N/A	Pass
	46	5230		46.83		Pass
	54	5270		40.77		Pass
	62	5310		40.67		Pass
	102	5510		41.77		Pass
	118	5590		40.48		Pass
	134	5670		40.77		Pass
	151	5755	35.91		>0.5	Pass
	159	5795	36.30			Pass
802.11ac (VHT80) Chain0	42	5210		80.83	N/A	Pass
	58	5290		80.76		Pass
	106	5530		87.31		Pass
	122	5610		82.85		Pass
	155	5775	75.15		>0.5	Pass
802.11ac (VHT80) Chain1	42	5210		81.25	N/A	Pass
	58	5290		80.47		Pass
	106	5530		81.14		Pass
	122	5610		80.55		Pass
	155	5775	75.17		>0.5	Pass

Chain0 : 26dB Bandwidth @ 802.11a Mode Ch36



Chain0 : 26dB Bandwidth @ 802.11a Mode Ch44

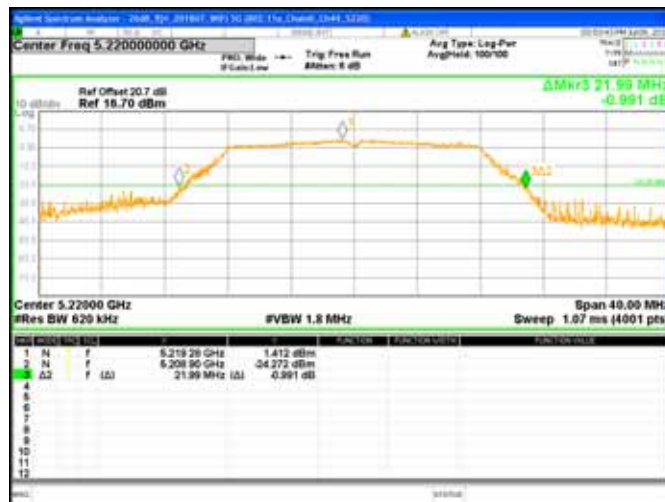

Chain0 : 26dB Bandwidth @ 802.11a Mode Ch48



Chain0 : 26dB Bandwidth @ 802.11a Mode Ch52



Chain0 : 26dB Bandwidth @ 802.11a Mode Ch60



Chain0 : 26dB Bandwidth @ 802.11a Mode Ch64



Chain0 : 26dB Bandwidth @ 802.11a Mode Ch100



Chain0 : 26dB Bandwidth @ 802.11a Mode Ch120



Chain0 : 26dB Bandwidth @ 802.11a Mode Ch140



Chain0 : 26dB Bandwidth @ 802.11a Mode Ch149



Chain0 : 26dB Bandwidth @ 802.11a Mode Ch157



Chain0 : 26dB Bandwidth @ 802.11a Mode Ch165



Chain1 : 26dB Bandwidth @ 802.11a Mode Ch36



Chain1 : 26dB Bandwidth @ 802.11a Mode Ch44



Chain1 : 26dB Bandwidth @ 802.11a Mode Ch48



Chain1 : 26dB Bandwidth @ 802.11a Mode Ch52



Chain1 : 26dB Bandwidth @ 802.11a Mode Ch60



Chain1 : 26dB Bandwidth @ 802.11a Mode Ch64



Chain1 : 26dB Bandwidth @ 802.11a Mode Ch100



Chain1 : 26dB Bandwidth @ 802.11a Mode Ch120



Chain1 : 26dB Bandwidth @ 802.11a Mode Ch140



Chain1 : 26dB Bandwidth @ 802.11a Mode Ch149



Chain1 : 26dB Bandwidth @ 802.11a Mode Ch157



Chain1 : 26dB Bandwidth @ 802.11a Mode Ch165



Chain0 : 26dB Bandwidth @ 802.11ac(VHT20) Mode Ch36



Chain0 : 26dB Bandwidth @ 802.11ac(VHT20) Mode Ch44



Chain0 : 26dB Bandwidth @ 802.11ac(VHT20) Mode Ch48



Chain0 : 26dB Bandwidth @ 802.11ac(VHT20) Mode Ch52



Chain0 : 26dB Bandwidth @ 802.11ac(VHT20) Mode Ch60



Chain0 : 26dB Bandwidth @ 802.11ac(VHT20) Mode Ch64



Chain0 : 26dB Bandwidth @ 802.11ac(VHT20) Mode Ch100



Chain0 : 26dB Bandwidth @ 802.11ac(VHT20) Mode Ch120



Chain0 : 26dB Bandwidth @ 802.11ac(VHT20) Mode Ch140



Chain0 : 26dB Bandwidth @ 802.11ac(VHT20) Mode Ch149



Chain0 : 26dB Bandwidth @ 802.11ac(VHT20) Mode Ch157



Chain0 : 26dB Bandwidth @ 802.11ac(VHT20) Mode Ch165



Chain1 : 26dB Bandwidth @ 802.11ac(VHT20) Mode Ch36



Chain1 : 26dB Bandwidth @ 802.11ac(VHT20) Mode Ch44



Chain1 : 26dB Bandwidth @ 802.11ac(VHT20) Mode Ch48



Chain1 : 26dB Bandwidth @ 802.11ac(VHT20) Mode Ch52



Chain1 : 26dB Bandwidth @ 802.11ac(VHT20) Mode Ch60



Chain1 : 26dB Bandwidth @ 802.11ac(VHT20) Mode Ch64



Chain1 : 26dB Bandwidth @ 802.11ac(VHT20) Mode Ch100



Chain1 : 26dB Bandwidth @ 802.11ac(VHT20) Mode Ch120



Chain1 : 26dB Bandwidth @ 802.11ac(VHT20) Mode Ch140



Chain1 : 26dB Bandwidth @ 802.11ac(VHT20) Mode Ch149



Chain1 : 26dB Bandwidth @ 802.11ac(VHT20) Mode Ch157



Chain1 : 26dB Bandwidth @ 802.11ac(VHT20) Mode Ch165



Chain0 : 26dB Bandwidth @ 802.11ac(VHT40) Mode Ch38



Chain0 : 26dB Bandwidth @ 802.11ac(VHT40) Mode Ch46



Chain0 : 26dB Bandwidth @ 802.11ac(VHT40) Mode Ch54



Chain0 : 26dB Bandwidth @ 802.11ac(VHT40) Mode Ch62



Chain0 : 26dB Bandwidth @ 802.11ac(VHT40) Mode Ch102



Chain0 : 26dB Bandwidth @ 802.11ac(VHT40) Mode Ch118

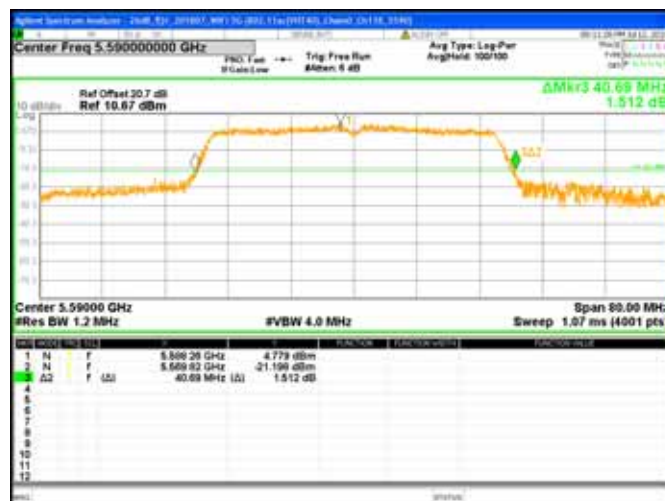

Chain0 : 26dB Bandwidth @ 802.11ac(VHT40) Mode Ch134



Chain0 : 26dB Bandwidth @ 802.11ac(VHT40) Mode Ch151



Chain0 : 26dB Bandwidth @ 802.11ac(VHT40) Mode Ch159

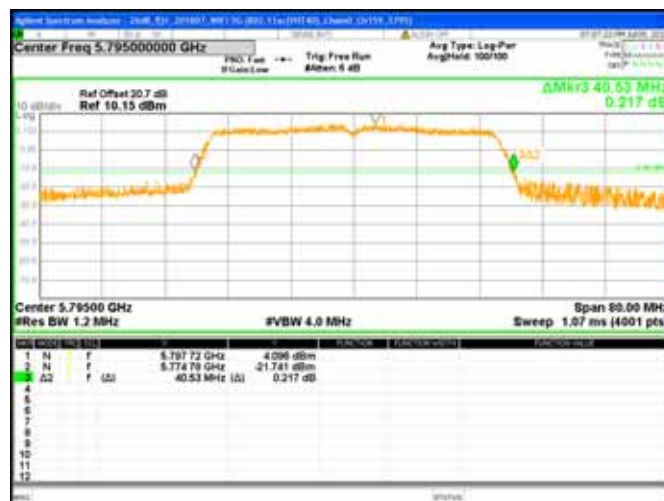

Chain1 : 26dB Bandwidth @ 802.11ac(VHT40) Mode Ch38



Chain1 : 26dB Bandwidth @ 802.11ac(VHT40) Mode Ch46



Chain1 : 26dB Bandwidth @ 802.11ac(VHT40) Mode Ch54



Chain1 : 26dB Bandwidth @ 802.11ac(VHT40) Mode Ch62



Chain1 : 26dB Bandwidth @ 802.11ac(VHT40) Mode Ch102



Chain1 : 26dB Bandwidth @ 802.11ac(VHT40) Mode Ch118



Chain1 : 26dB Bandwidth @ 802.11ac(VHT40) Mode Ch134



Chain1 : 26dB Bandwidth @ 802.11ac(VHT40) Mode Ch151



Chain1 : 26dB Bandwidth @ 802.11ac(VHT40) Mode Ch159



Chain0 : 26dB Bandwidth @ 802.11ac(VHT80) Mode Ch42



Chain0 : 26dB Bandwidth @ 802.11ac(VHT80) Mode Ch58



Chain0 : 26dB Bandwidth @ 802.11ac(VHT80) Mode Ch106



Chain0 : 26dB Bandwidth @ 802.11ac(VHT80) Mode Ch122



Chain0 : 26dB Bandwidth @ 802.11ac(VHT80) Mode Ch155



Chain1 : 26dB Bandwidth @ 802.11ac(VHT80) Mode Ch42



Chain1 : 26dB Bandwidth @ 802.11ac(VHT80) Mode Ch58



Chain1 : 26dB Bandwidth @ 802.11ac(VHT80) Mode Ch106



Chain1 : 26dB Bandwidth @ 802.11ac(VHT80) Mode Ch122



Chain1 : 26dB Bandwidth @ 802.11ac(VHT80) Mode Ch155



Chain0 : 6dB Bandwidth @ 802.11a Mode Ch36



Chain0 : 6dB Bandwidth @ 802.11a Mode Ch44



Chain0 : 6dB Bandwidth @ 802.11a Mode Ch48

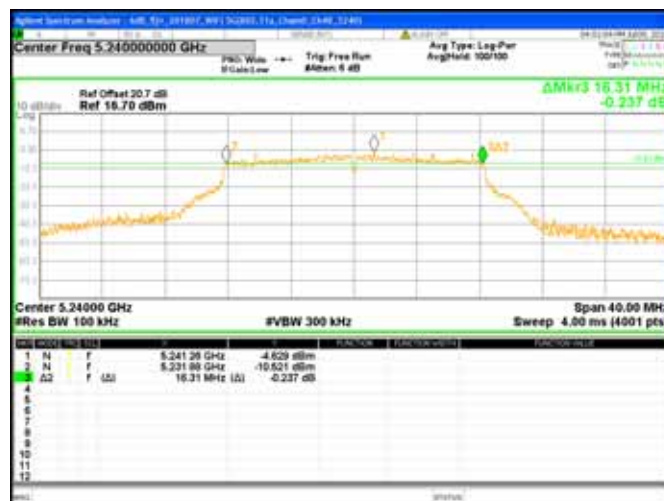

Chain0 : 6dB Bandwidth @ 802.11a Mode Ch52



Chain0 : 6dB Bandwidth @ 802.11a Mode Ch60



Chain0 : 6dB Bandwidth @ 802.11a Mode Ch64

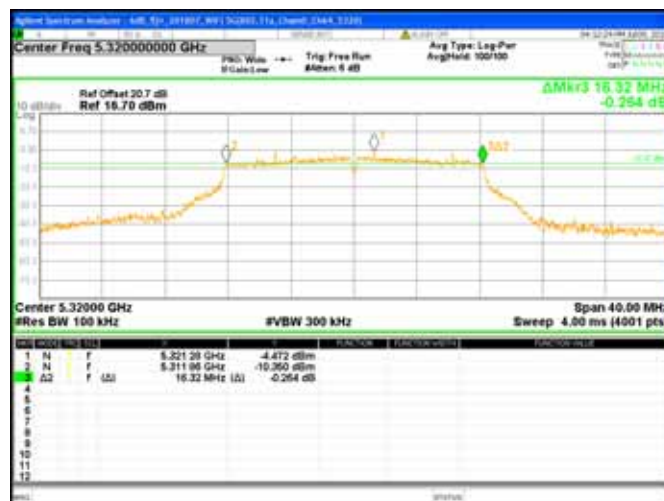

Chain0 : 6dB Bandwidth @ 802.11a Mode Ch100



Chain0 : 6dB Bandwidth @ 802.11a Mode Ch120



Chain0 : 6dB Bandwidth @ 802.11a Mode Ch140



Chain0 : 6dB Bandwidth @ 802.11a Mode Ch149



Chain0 : 6dB Bandwidth @ 802.11a Mode Ch157



Chain0 : 6dB Bandwidth @ 802.11a Mode Ch165



Chain1 : 6dB Bandwidth @ 802.11a Mode Ch36



Chain1 : 6dB Bandwidth @ 802.11a Mode Ch44



Chain1 : 6dB Bandwidth @ 802.11a Mode Ch48



Chain1 : 6dB Bandwidth @ 802.11a Mode Ch52



Chain1 : 6dB Bandwidth @ 802.11a Mode Ch60



Chain1 : 6dB Bandwidth @ 802.11a Mode Ch64



Chain1 : 6dB Bandwidth @ 802.11a Mode Ch100



Chain1 : 6dB Bandwidth @ 802.11a Mode Ch120



Chain1 : 6dB Bandwidth @ 802.11a Mode Ch140



Chain1 : 6dB Bandwidth @ 802.11a Mode Ch149



Chain1 : 6dB Bandwidth @ 802.11a Mode Ch157



Chain1 : 6dB Bandwidth @ 802.11a Mode Ch165



Chain0 : 6dB Bandwidth @ 802.11ac(VHT20) Mode Ch36

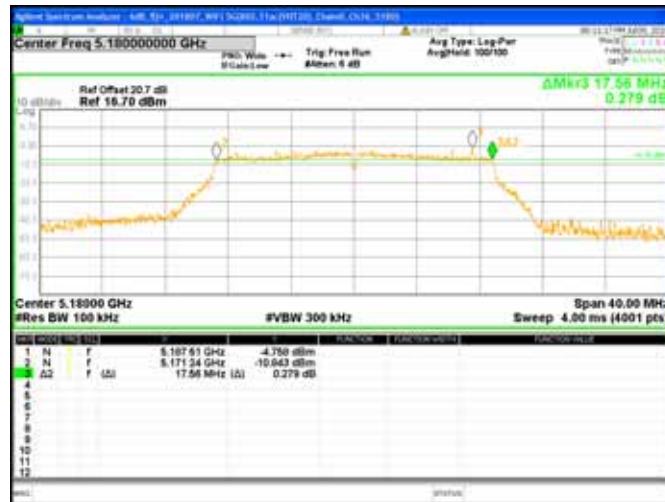

Chain0 : 6dB Bandwidth @ 802.11ac(VHT20) Mode Ch44

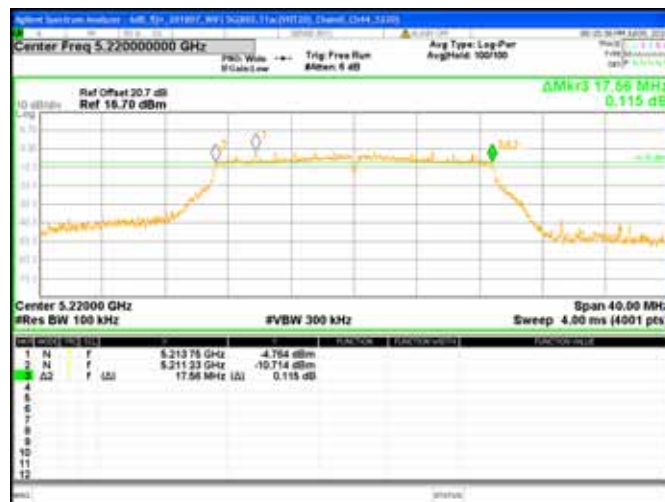

Chain0 : 6dB Bandwidth @ 802.11ac(VHT20) Mode Ch48



Chain0 : 6dB Bandwidth @ 802.11ac(VHT20) Mode Ch52



Chain0 : 6dB Bandwidth @ 802.11ac(VHT20) Mode Ch60



Chain0 : 6dB Bandwidth @ 802.11ac(VHT20) Mode Ch64



Chain0 : 6dB Bandwidth @ 802.11ac(VHT20) Mode Ch100



Chain0 : 6dB Bandwidth @ 802.11ac(VHT20) Mode Ch120



Chain0 : 6dB Bandwidth @ 802.11ac(VHT20) Mode Ch140



Chain0 : 6dB Bandwidth @ 802.11ac(VHT20) Mode Ch149



Chain0 : 6dB Bandwidth @ 802.11ac(VHT20) Mode Ch157



Chain0 : 6dB Bandwidth @ 802.11ac(VHT20) Mode Ch165



Chain1 : 6dB Bandwidth @ 802.11ac(VHT20) Mode Ch36



Chain1 : 6dB Bandwidth @ 802.11ac(VHT20) Mode Ch44

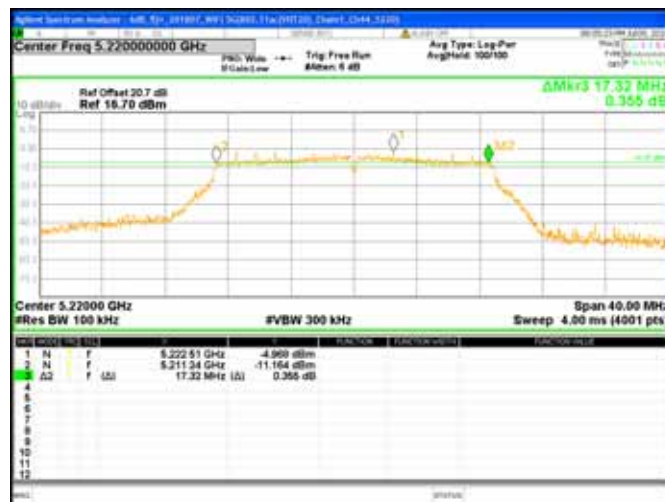

Chain1 : 6dB Bandwidth @ 802.11ac(VHT20) Mode Ch48



Chain1 : 6dB Bandwidth @ 802.11ac(VHT20) Mode Ch52



Chain1 : 6dB Bandwidth @ 802.11ac(VHT20) Mode Ch60

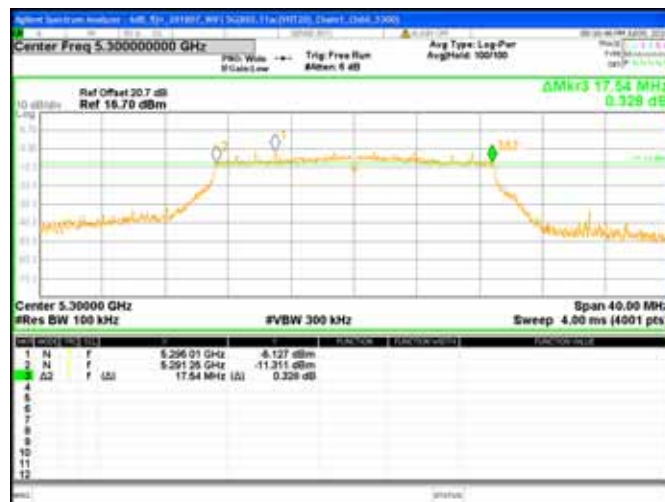

Chain1 : 6dB Bandwidth @ 802.11ac(VHT20) Mode Ch64



Chain1 : 6dB Bandwidth @ 802.11ac(VHT20) Mode Ch100



Chain1 : 6dB Bandwidth @ 802.11ac(VHT20) Mode Ch120



Chain1 : 6dB Bandwidth @ 802.11ac(VHT20) Mode Ch140



Chain1 : 6dB Bandwidth @ 802.11ac(VHT20) Mode Ch149



Chain1 : 6dB Bandwidth @ 802.11ac(VHT20) Mode Ch157



Chain1 : 6dB Bandwidth @ 802.11ac(VHT20) Mode Ch165



Chain0 : 6dB Bandwidth @ 802.11ac(VHT40) Mode Ch38

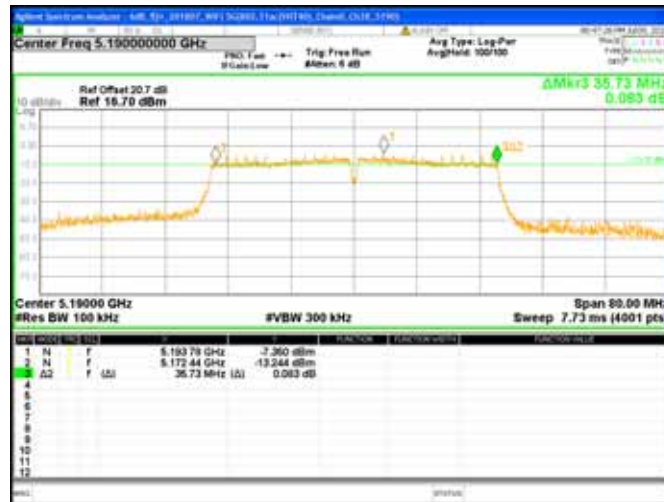

Chain0 : 6dB Bandwidth @ 802.11ac(VHT40) Mode Ch46



Chain0 : 6dB Bandwidth @ 802.11ac(VHT40) Mode Ch54

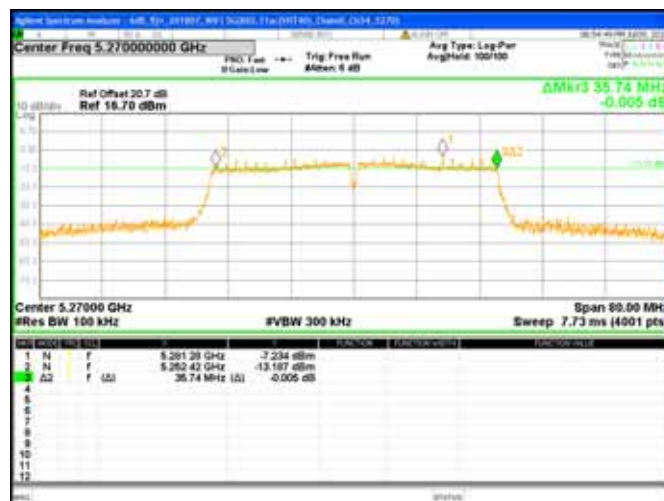

Chain0 : 6dB Bandwidth @ 802.11ac(VHT40) Mode Ch62



Chain0 : 6dB Bandwidth @ 802.11ac(VHT40) Mode Ch102



Chain0 : 6dB Bandwidth @ 802.11ac(VHT40) Mode Ch118



Chain0 : 6dB Bandwidth @ 802.11ac(VHT40) Mode Ch134



Chain0 : 6dB Bandwidth @ 802.11ac(VHT40) Mode Ch151



Chain0 : 6dB Bandwidth @ 802.11ac(VHT40) Mode Ch159



Chain1 : 6dB Bandwidth @ 802.11ac(VHT40) Mode Ch38



Chain1 : 6dB Bandwidth @ 802.11ac(VHT40) Mode Ch46



Chain1 : 6dB Bandwidth @ 802.11ac(VHT40) Mode Ch54



Chain1 : 6dB Bandwidth @ 802.11ac(VHT40) Mode Ch62



Chain1 : 6dB Bandwidth @ 802.11ac(VHT40) Mode Ch102

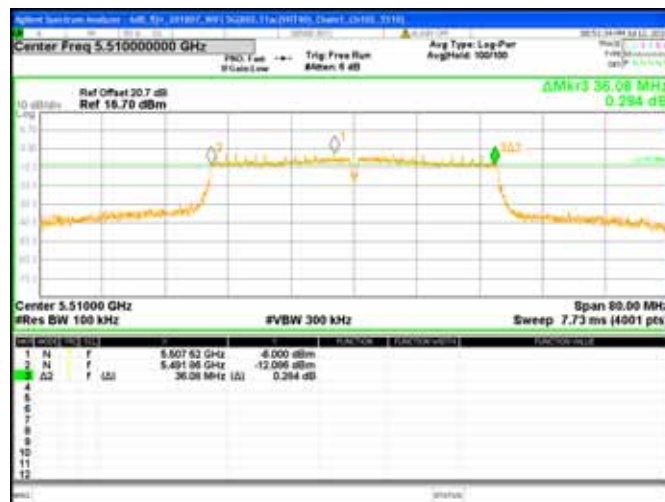

Chain1 : 6dB Bandwidth @ 802.11ac(VHT40) Mode Ch118



Chain1 : 6dB Bandwidth @ 802.11ac(VHT40) Mode Ch134



Chain1 : 6dB Bandwidth @ 802.11ac(VHT40) Mode Ch151



Chain1 : 6dB Bandwidth @ 802.11ac(VHT40) Mode Ch159

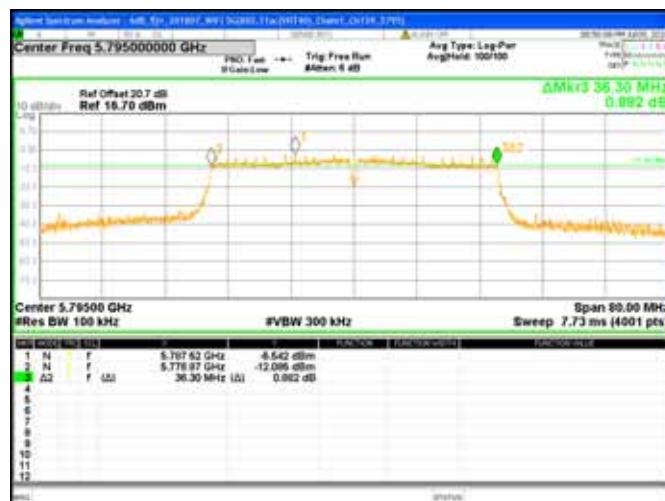

Chain0 : 6dB Bandwidth @ 802.11ac(VHT80) Mode Ch42



Chain0 : 6dB Bandwidth @ 802.11ac(VHT80) Mode Ch58

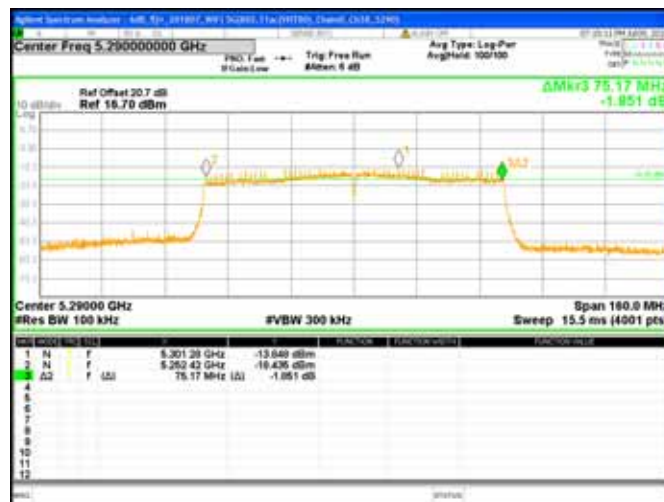

Chain0 : 6dB Bandwidth @ 802.11ac(VHT80) Mode Ch106



Chain0 : 6dB Bandwidth @ 802.11ac(VHT80) Mode Ch122



Chain0 : 6dB Bandwidth @ 802.11ac(VHT80) Mode Ch155



Chain1 : 6dB Bandwidth @ 802.11ac(VHT80) Mode Ch42



Chain1 : 6dB Bandwidth @ 802.11ac(VHT80) Mode Ch58

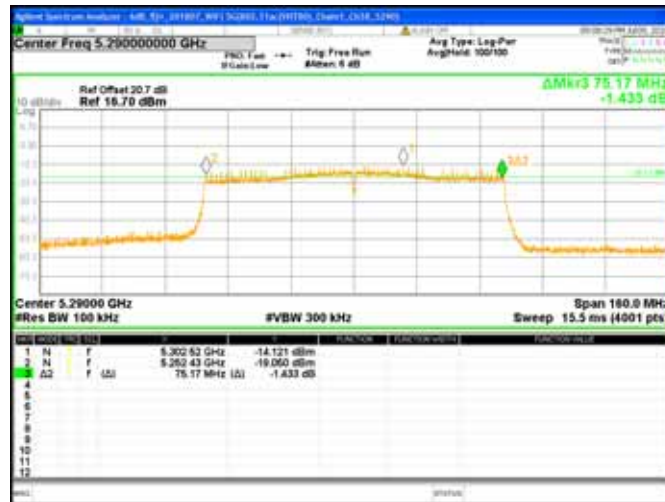

Chain1 : 6dB Bandwidth @ 802.11ac(VHT80) Mode Ch106

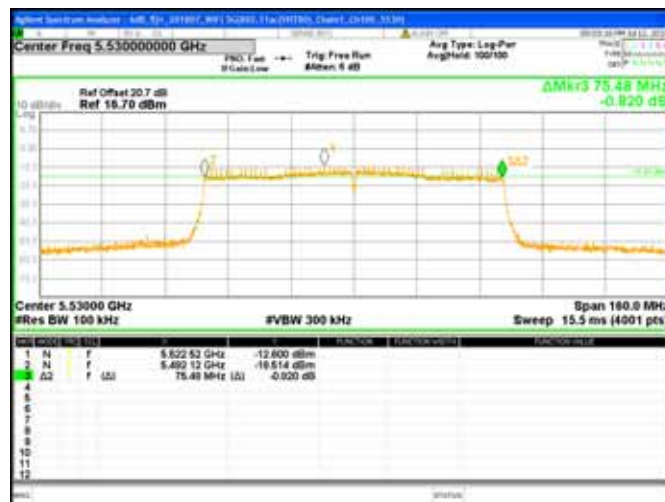

Chain1 : 6dB Bandwidth @ 802.11ac(VHT80) Mode Ch122



Chain1 : 6dB Bandwidth @ 802.11ac(VHT80) Mode Ch155

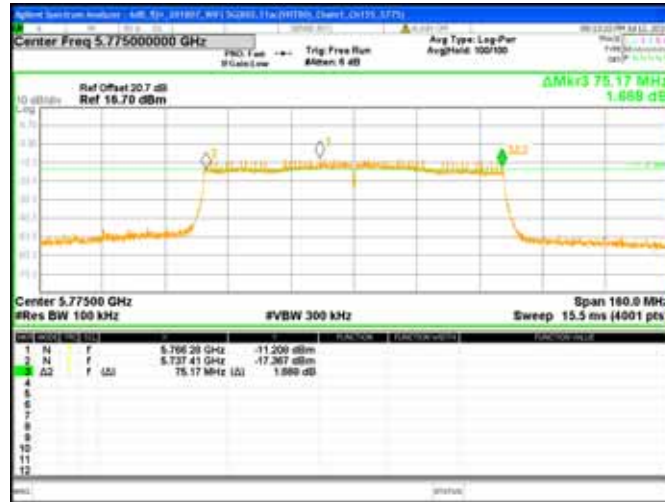

5. Emissions in Restricted Frequency Bands (Radiated emission measurements)

5.1 Operating environment

Temperature:	25	
Relative Humidity:	55	%
Atmospheric Pressure	1008	hPa
Channel number	36,44,48,149,157,161 for 20MHz 38,46,151,159 for 40MHz	

5.2 Limit for emission in restricted frequency bands (Radiated emission measurement)

Frequency (MHz)	Field Strength (microvolts/meter)	Measurement distance (meters)
0.009~0.490	2400/F(kHz)	300
0.490~1.705	2400/F(kHz)	30
1.705~30	30	30
30-88	100	3
88-216	150	3
216-960	200	3
Above 960	500	3

Remark:

1. In the above table, the tighter limit applies at the band edges.
2. Distance refers to the distance in meters between the measuring instrument antenna and the closed point of any part of the device or system

As specified in 15.407(b), For transmitters operating in the 5.15-5.25 GHz band: All emissions outside of the 5.15-5.35 GHz band shall not exceed an e.i.r.p. of -27 dBm/MHz.

(2) For transmitters operating in the 5.25-5.35 GHz band: All emissions outside of the 5.15-5.35 GHz band shall not exceed an e.i.r.p. of -27 dBm/MHz.

(3) For transmitters operating in the 5.47-5.725 GHz band: All emissions outside of the 5.47-5.725 GHz band shall not exceed an e.i.r.p. of -27 dBm/MHz.

(4) For transmitters operating in the 5.725-5.85 GHz band:

All emissions shall be limited to a level of -27 dBm/MHz at 75 MHz or more above or below the band edge increasing linearly to 10 dBm/MHz at 25 MHz above or below the band edge, and from 25 MHz above or below the band edge increasing linearly to a level of 15.6 dBm/MHz at 5 MHz above or below the band edge, and from 5 MHz above or below the band edge increasing linearly to a level of 27 dBm/MHz at the band edge.

However, an out-of-band emission that complies with both the average and peak limits of 15.209 is not required to satisfy the -27 dBm/MHz or -17 dBm/MHz peak emission limit.

5.3 Measuring instrument setting

Below 1GHz measurement

Receiver settings	
Receiver function	Setting
Detector	QP
RBW	9-150 kHz ; 200-300 Hz 0.15-30 MHz; 9-10 kHz 30-1000 MHz; 100-120 kHz
VBW	3 x RBW
Sweep	Auto couple
Attenuation	Auto

Above 1GHz measurement

Spectrum analyzer settings	
Spectrum Analyzer function	Setting
Detector	Peak
RBW	1MHz
VBW	3MHz for Peak; 10Hz for Average
Sweep	Auto couple
Start Frequency	1GHz
Stop Frequency	Tenth harmonic
Attenuation	Auto

5.4 Test procedure

1. Configure the EUT according to ANSI C63.10: 2013 The EUT was placed on the top of the turntable 1.5 meter above ground for above 1GHz and placed on the top of the turntable 0.8 meter above ground for below 1GHz. The center of the receiving antenna mounted on the top of a height-variable antenna tower was placed 3 meters far away from the turntable.
2. Power on the EUT and all the companion devices. The turntable was rotated by 360 degree to find the position of the maximum emission level.
3. The height of the receiving antenna was varied between one meter and four meters above ground to find the maximum emission field strength of the both horizontal and vertical polarization
4. If find the frequencies above the limit or below within 3dB, the antenna tower was scan (from 1m to 4m) and then the turntable was rotated to find the maximum reading.
5. Set the test-receiver system to peak or CISPR quasi-peak detector with specified bandwidth under maximum hold mode.
6. For emissions above 1GHz, use 1MHz VBW and 3MHz RBW for peak reading. Then 1MHz RBW and 10Hz VBW for average reading in spectrum analyzer.
Place the measurement antenna away from each area of the EUT determined to be a source of emissions at the specified measurement distance, while keeping the measurement antenna aimed at the source of emissions at each frequency of significant emissions, with polarization oriented for maximum response.
7. If the emissions level of the EUT in peak mode was 3dB lower than the average limit specified then testing will be stopped and peak values of the EUT will be reported. Otherwise, the emissions which do not have 3dB margin will be measured using the quasi-peak method for below 1GHz.
8. For testing above 1GHz, The emissions level of the EUT in peak mode was lower than average limit, then testing will be stopped and peak values of the EUT will be reported, otherwise, the emission will be measured in average mode again and reported.
9. In case the emission is lower than 30MHz, loop antenna has to be used for measurement and the recorded data should be quasi-peak measured by receiver.

5.5 Test configuration

5.5.1 Radiated emission from 9 kHz to 30MHz using Loop Antenna

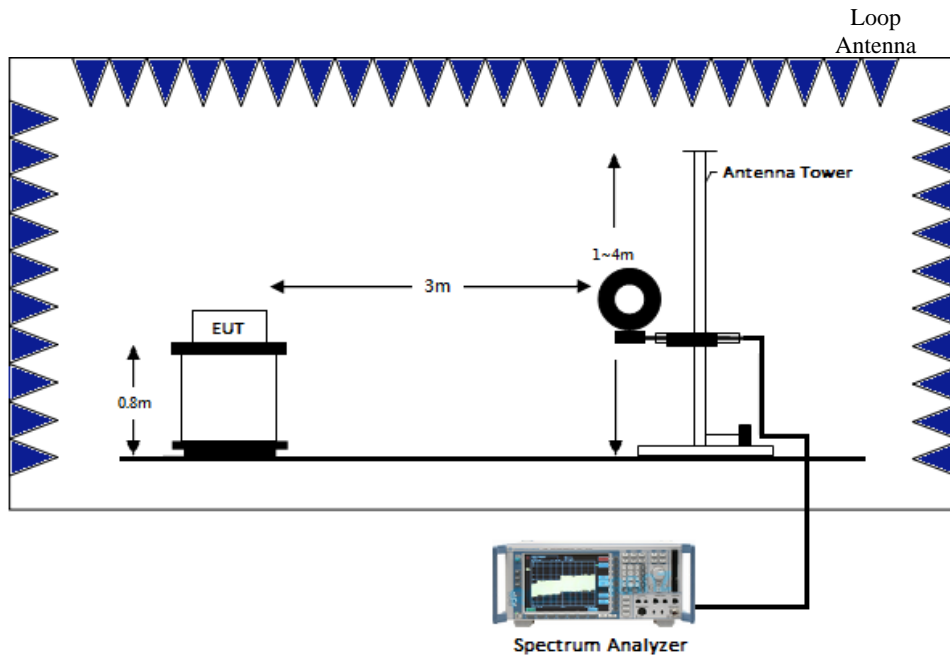

5.5.2 Radiated emission below 1GHz using Bilog Antenna

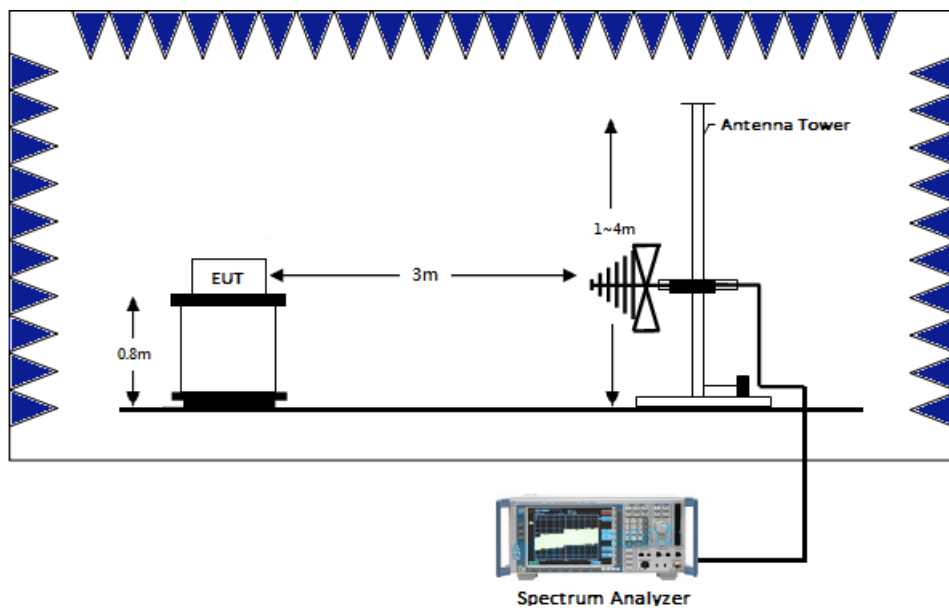

5.5.3 Radiated emission above 1GHz using Horn Antenna

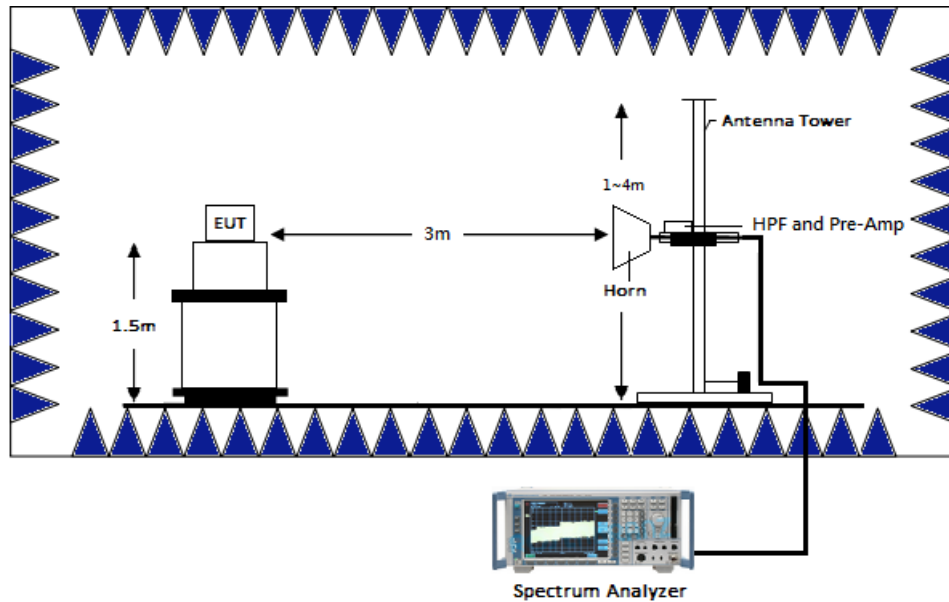

5.6 Test results

5.6.1 Measurement results: frequencies from 9 kHz to 30MHz

Frequency (MHz)	Detection value	Factor (dB/m)	Reading (dBμV)	Value (dBμV/m)	Limit @ 3m (dBμV/m)	Tolerance (dB)
0.02	PK	19.27	28.13	47.40	121.58	-74.18
0.03	PK	19.52	29.49	49.01	118.06	-69.05
0.07	PK	18.97	31.15	50.12	110.70	-60.58
0.09	PK	18.80	31.08	49.88	108.52	-58.64
0.10	QP	18.77	30.44	49.21	107.60	-58.39
0.13	PK	18.74	27.71	46.45	105.33	-58.88
0.15	PK	18.73	34.07	52.80	104.08	-51.28
0.21	PK	18.73	30.79	49.52	101.16	-51.64
0.33	PK	18.75	27.14	45.89	97.23	-51.34
0.45	PK	18.67	25.77	44.44	94.54	-50.10
0.57	QP	18.63	23.56	42.19	72.49	-30.30
0.69	QP	18.61	22.57	41.18	70.83	-29.65

Remark: Corr. Factor = Antenna Factor + Cable Loss - PreAmplifier Gain

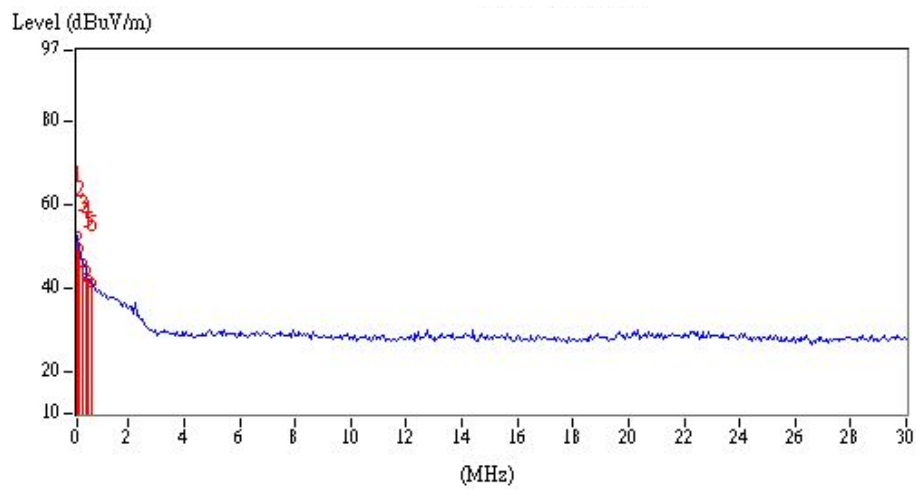
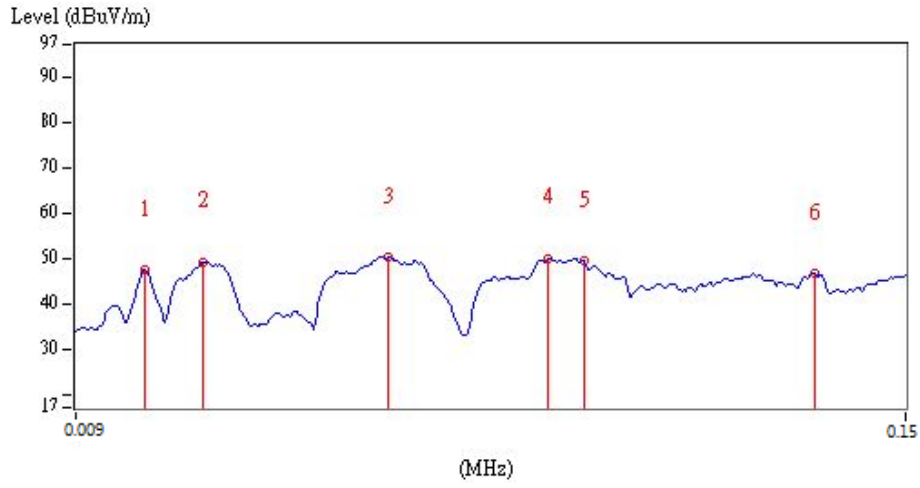

TEST REPORT

5.6.2 Measurement results: frequencies from 30 MHz to 1GHz

The test was performed on EUT under 802.11a/an continuously transmitting mode. The worst case occurred at 802.11ac(VHT20) Chain0+1 Channel 165

Antenna Polariz. (V/H)	Freq. (MHz)	Receiver Detector	Corr. Factor (dB/m)	Reading (dBuV)	Corrected Level (dBuV/m)	Limit @ 3 m (dBuV/m)	Margin (dB)
Vertical	39.70	QP	19.92	10.21	30.13	40.00	-9.87
Vertical	643.04	QP	29.61	14.00	43.61	46.00	-2.39
Vertical	714.82	QP	30.84	11.20	42.04	46.00	-3.96
Vertical	786.60	QP	31.95	9.50	41.45	46.00	-4.55
Vertical	858.38	QP	32.78	12.63	45.41	46.00	-0.59
Vertical	930.16	QP	33.68	4.38	38.06	46.00	-7.94
Horizontal	214.30	QP	18.85	22.89	41.74	43.50	-1.76
Horizontal	357.86	QP	23.16	10.22	33.38	46.00	-12.62
Horizontal	643.04	QP	29.61	8.06	37.67	46.00	-8.33
Horizontal	714.82	QP	30.84	8.43	39.27	46.00	-6.73
Horizontal	786.60	QP	31.95	13.43	45.38	46.00	-0.62
Horizontal	858.38	QP	32.78	11.65	44.43	46.00	-1.57

Remark:

1. Corr. Factor = Antenna Factor + Cable Loss
2. Corrected Level = Reading + Corr. Factor

Vertical

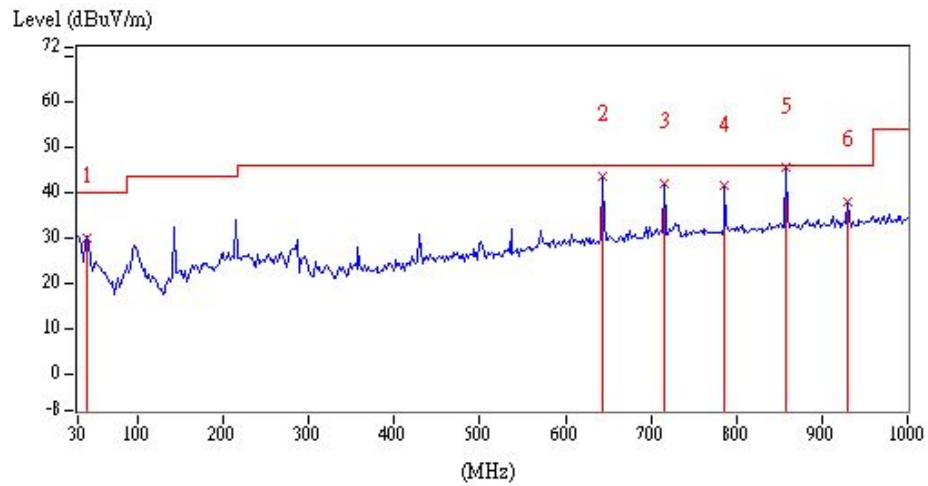

Horizontal

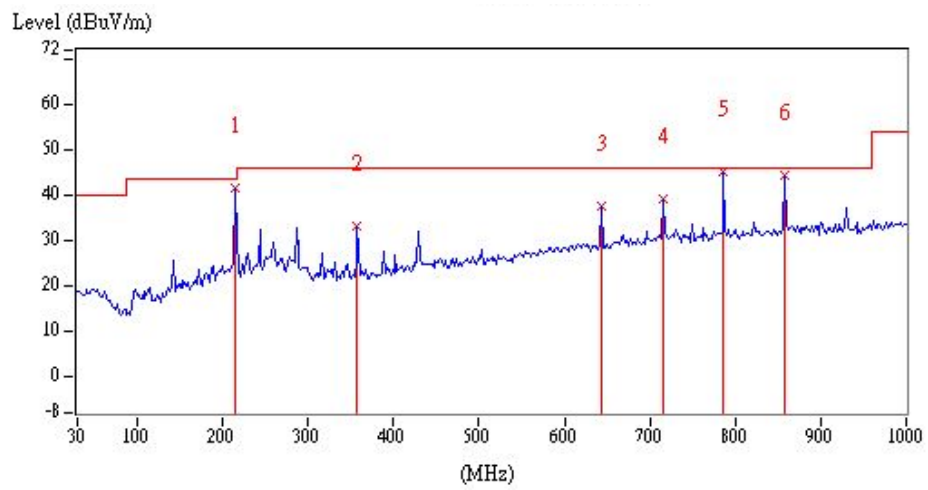

TEST REPORT

5.6.3 Measurement results: frequency above 1GHz to 40GHz

Chain0

Mode	Frequency (MHz)	Spectrum Analyzer Detector	Ant. Pol. (H/V)	Preamp. Gain (dB)	Correction Factor (dB/m)	Reading (dBμV)	Corrected Reading (dBμV/m)	Limit @ 3 m (dBμV/m)	Margin (dB)
802.11a_Ch36	1144	PK	H	37.28	-7.93	54.80	46.87	74.00	-27.13
	10360	PK	H	35.77	20.14	25.54	45.67	74.00	-28.33
	1144	PK	V	37.28	-7.93	61.08	53.15	74.00	-20.85
	1209	PK	V	37.29	-7.83	52.74	44.91	74.00	-29.09
	1572	PK	V	37.37	-6.52	49.97	43.45	74.00	-30.55
	1924	PK	V	37.37	-2.33	42.94	40.60	74.00	-33.40
	2210	PK	V	37.37	-1.74	43.30	41.56	74.00	-32.44
	2716	PK	V	37.40	-1.03	41.61	40.58	74.00	-33.42
	6159	PK	V	36.84	7.99	39.07	47.06	74.00	-26.94
	10360	PK	V	35.77	20.14	25.37	45.51	74.00	-28.49
802.11a_Ch44	1144	PK	H	37.28	-7.93	54.97	47.03	74.00	-26.97
	10440	PK	H	35.73	20.59	25.44	46.03	74.00	-27.97
	1144	PK	V	37.28	-7.93	59.81	51.87	74.00	-22.13
	1209	PK	V	37.29	-7.83	48.37	40.54	74.00	-33.46
	1572	PK	V	37.37	-6.52	50.54	44.01	74.00	-29.99
	1924	PK	V	37.37	-2.33	43.72	41.39	74.00	-32.61
	2716	PK	V	37.40	-1.03	40.99	39.96	74.00	-34.04
	6247	PK	V	36.81	8.28	39.25	47.54	74.00	-26.46
	10440	PK	V	35.73	20.59	25.54	46.13	74.00	-27.87
802.11a_Ch48	1144	PK	H	37.28	-7.93	54.81	46.88	74.00	-27.12
	10480	PK	H	35.71	20.81	25.22	46.03	74.00	-27.97
	1144	PK	V	37.28	-7.93	61.40	53.46	74.00	-20.54
	1209	PK	V	37.29	-7.83	52.17	44.34	74.00	-29.66
	1572	PK	V	37.37	-6.52	49.53	43.01	74.00	-30.99
	1924	PK	V	37.37	-2.33	42.03	39.7	74.00	-34.30
	2716	PK	V	37.40	-1.03	41.33	40.3	74.00	-33.70
	6280	PK	V	36.80	8.39	39.16	47.55	74.00	-26.45
	10480	PK	V	35.71	20.81	24.28	45.09	74.00	-28.91

Remark: Correction Factor = Antenna Factor + Cable Loss + High Pass Filter Loss - Pre_Amplifier Gain

Chain0

Mode	Frequency (MHz)	Spectrum Analyzer Detector	Ant. Pol. (H/V)	Preamp. Gain (dB)	Correction Factor (dB/m)	Reading (dBμV)	Corrected Reading (dBμV/m)	Limit @ 3 m (dBμV/m)	Margin (dB)
802.11a_Ch52	1144	PK	H	37.28	-7.93	53.76	45.82	74.00	-28.18
	10520	PK	H	35.70	21.01	25.95	46.97	74.00	-27.03
	1144	PK	V	37.28	-7.93	63.25	55.31	74.00	-18.69
	1144	AV	V	37.28	-7.93	53.98	46.05	54.00	-7.95
	1209	PK	V	37.29	-7.83	48.35	40.52	74.00	-33.48
	1572	PK	V	37.37	-6.52	50.13	43.6	74.00	-30.40
	1924	PK	V	37.37	-2.33	42.53	40.2	74.00	-33.80
	2716	PK	V	37.40	-1.03	41.27	40.24	74.00	-33.76
	6324	PK	V	36.78	8.54	40.45	48.99	74.00	-25.01
	10520	PK	V	35.70	21.01	23.76	44.78	74.00	-29.22
802.11a_Ch60	1144	PK	H	37.28	-7.93	50.47	42.53	74.00	-31.47
	10600	PK	H	35.71	21.36	23.47	44.83	74.00	-29.17
	1144	PK	V	37.28	-7.93	63.75	55.81	74.00	-18.19
	1144	AV	V	37.28	-7.93	53.85	45.92	54.00	-8.08
	1572	PK	V	37.37	-6.52	51.88	45.36	74.00	-28.64
	1781	PK	V	37.37	-4.04	48.02	43.98	74.00	-30.02
	2144	PK	V	37.37	-1.64	48.87	47.23	74.00	-26.77
	2716	PK	V	37.40	-1.03	42.90	41.87	74.00	-32.13
	6401	PK	V	36.76	8.80	42.28	51.08	74.00	-22.92
	10600	PK	V	35.71	21.36	24.31	45.68	74.00	-28.32
802.11a_Ch64	1144	PK	H	37.28	-7.93	55.77	47.84	74.00	-26.16
	10640	PK	H	35.71	21.54	24.83	46.37	74.00	-27.63
	1144	PK	V	37.28	-7.93	61.30	53.37	74.00	-20.63
	1209	PK	V	37.29	-7.83	47.39	39.56	74.00	-34.44
	1572	PK	V	37.37	-6.52	50.02	43.5	74.00	-30.50
	1715	PK	V	37.37	-4.82	45.54	40.72	74.00	-33.28
	2144	PK	V	37.37	-1.64	43.65	42	74.00	-32.00
	6445	PK	V	36.74	8.94	44.32	53.26	74.00	-20.74
	10640	PK	V	35.71	21.54	23.37	44.91	74.00	-29.09

Remark: Correction Factor = Antenna Factor + Cable Loss + High Pass Filter Loss - Pre_Amplifier Gain

TEST REPORT

Mode	Frequency (MHz)	Spectrum Analyzer Detector	Ant. Pol. (H/V)	Preamp. Gain (dB)	Correction Factor (dB/m)	Reading (dBμV)	Corrected Reading (dBμV/m)	Limit @ 3 m (dBμV/m)	Margin (dB)
802.11a_Ch100	1144	PK	H	37.28	-7.93	50.38	42.45	74.00	-31.55
	1781	PK	H	37.37	-4.04	44.49	40.46	74.00	-33.54
	11000	PK	H	35.73	23.11	25.07	48.18	74.00	-25.82
	1144	PK	V	37.28	-7.93	63.08	55.15	74.00	-18.85
	1144	AV	V	37.28	-7.93	54.50	46.57	54.00	-7.43
	1572	PK	V	37.37	-6.52	50.46	43.94	74.00	-30.06
	1781	PK	V	37.37	-4.04	45.26	41.23	74.00	-32.77
	2144	PK	V	37.37	-1.64	44.18	42.54	74.00	-31.46
	2716	PK	V	37.40	-1.03	43.16	42.13	74.00	-31.87
	11000	PK	V	35.73	23.11	24.28	47.39	74.00	-26.61
802.11a_Ch120	1144	PK	H	37.28	-7.93	54.00	46.06	74.00	-27.94
	11200	PK	H	35.74	23.31	23.68	46.99	74.00	-27.01
	1144	PK	V	37.28	-7.93	62.05	54.12	74.00	-19.88
	1144	AV	V	37.28	-7.93	54.46	46.53	54.00	-7.47
	1209	PK	V	37.29	-7.83	47.87	40.03	74.00	-33.97
	1572	PK	V	37.37	-6.52	50.53	44.01	74.00	-29.99
	1781	PK	V	37.37	-4.04	51.90	47.86	74.00	-26.14
	2716	PK	V	37.40	-1.03	46.78	45.75	74.00	-28.25
	11200	PK	V	35.74	23.31	24.28	47.59	74.00	-26.41
802.11a_Ch140	1144	PK	H	37.28	-7.93	51.10	43.16	74.00	-30.84
	1572	PK	H	37.37	-6.52	43.88	37.36	74.00	-36.64
	11400	PK	H	35.75	23.50	22.81	46.32	74.00	-27.68
	1144	PK	V	37.28	-7.93	58.84	50.91	74.00	-23.09
	1209	PK	V	37.29	-7.83	49.14	41.31	74.00	-32.69
	1572	PK	V	37.37	-6.52	49.90	43.38	74.00	-30.62
	1715	PK	V	37.37	-4.82	48.36	43.54	74.00	-30.46
	2144	PK	V	37.37	-1.64	44.31	42.66	74.00	-31.34
	5851	PK	V	36.92	6.99	41.15	48.14	74.00	-25.86
	11400	PK	V	35.75	23.50	23.72	47.23	74.00	-26.77

Remark: Correction Factor = Antenna Factor + Cable Loss + High Pass Filter Loss - Pre_Amplifier Gain

TEST REPORT

Chain0

Mode	Frequency (MHz)	Spectrum Analyzer Detector	Ant. Pol. (H/V)	Preamp. Gain (dB)	Correction Factor (dB/m)	Reading (dBμV)	Corrected Reading (dBμV/m)	Limit @ 3 m (dBμV/m)	Margin (dB)
802.11a_Ch149	1144	PK	H	37.28	-7.93	52.07	44.13	74.00	-29.87
	1572	PK	H	37.37	-6.52	44.21	37.69	74.00	-36.31
	11490	PK	H	35.76	23.59	23.64	47.23	74.00	-26.77
	1144	PK	V	37.28	-7.93	60.71	52.77	74.00	-21.23
	1209	PK	V	37.29	-7.83	48.63	40.79	74.00	-33.21
	1572	PK	V	37.37	-6.52	52.06	45.54	74.00	-28.46
	1858	PK	V	37.37	-3.12	46.12	43	74.00	-31.00
	2716	PK	V	37.40	-1.03	42.35	41.32	74.00	-32.68
	11490	PK	V	35.76	23.59	24.47	48.06	74.00	-25.94
802.11a_Ch157	1144	PK	H	37.28	-7.93	54.15	46.21	74.00	-27.79
	1781	PK	H	37.37	-4.04	45.29	41.25	74.00	-32.75
	11570	PK	H	35.74	23.47	22.56	46.03	74.00	-27.97
	1144	PK	V	37.28	-7.93	56.88	48.95	74.00	-25.05
	1209	PK	V	37.29	-7.83	49.04	41.21	74.00	-32.79
	1572	PK	V	37.37	-6.52	50.57	44.05	74.00	-29.95
	1715	PK	V	37.37	-4.82	47.43	42.61	74.00	-31.39
	1858	PK	V	37.37	-3.12	44.04	40.92	74.00	-33.08
	2144	PK	V	37.37	-1.64	43.11	41.46	74.00	-32.54
	2716	PK	V	37.40	-1.03	41.77	40.74	74.00	-33.26
	11570	PK	V	35.74	23.47	23.75	47.22	74.00	-26.78
802.11a_Ch165	1144	PK	H	37.28	-7.93	53.62	45.69	74.00	-28.31
	1781	PK	H	37.37	-4.04	43.79	39.76	74.00	-34.24
	11650	PK	H	35.72	23.32	22.87	46.19	74.00	-27.81
	1144	PK	V	37.28	-7.93	59.58	51.65	74.00	-22.35
	1209	PK	V	37.29	-7.83	48.46	40.63	74.00	-33.37
	1572	PK	V	37.37	-6.52	49.83	43.31	74.00	-30.69
	1924	PK	V	37.37	-2.33	42.34	40.01	74.00	-33.99
	2716	PK	V	37.40	-1.03	47.08	46.05	74.00	-27.95
	11650	PK	V	35.72	23.32	22.97	46.3	74.00	-27.70

Remark: Correction Factor = Antenna Factor + Cable Loss + High Pass Filter Loss - Pre_Amplifier Gain

TEST REPORT

Chain1

Mode	Frequency (MHz)	Spectrum Analyzer Detector	Ant. Pol. (H/V)	Preamp. Gain (dB)	Correction Factor (dB/m)	Reading (dBμV)	Corrected Reading (dBμV/m)	Limit @ 3 m (dBμV/m)	Margin (dB)
802.11a_Ch36	1144	PK	H	37.28	-7.93	53.60	45.67	74.00	-28.33
	3563	PK	H	37.33	1.37	47.42	48.79	74.00	-25.21
	6159	PK	H	36.84	7.99	43.19	51.18	74.00	-22.82
	6478	PK	H	36.73	9.05	39.52	48.58	74.00	-25.42
	10360	PK	H	35.77	20.14	24.56	44.70	74.00	-29.30
	1144	PK	V	37.28	-7.93	62.00	54.07	74.00	-19.93
	1144	AV	V	37.28	-7.93	53.66	45.73	54.00	-8.27
	1572	PK	V	37.37	-6.52	50.05	43.52	74.00	-30.48
	2067	PK	V	37.37	-1.53	44.54	43.01	74.00	-30.99
	2353	PK	V	37.37	-1.95	45.45	43.50	74.00	-30.50
	2716	PK	V	37.40	-1.03	43.73	42.70	74.00	-31.30
	3563	PK	V	37.33	1.37	51.98	53.35	74.00	-20.65
	6159	PK	V	36.84	7.99	45.39	53.38	74.00	-20.62
	6489	PK	V	36.72	9.09	41.63	50.72	74.00	-23.28
	10360	PK	V	35.77	20.14	25.11	45.25	74.00	-28.75
802.11a_Ch44	1144	PK	H	37.28	-7.93	51.42	43.48	74.00	-30.52
	1572	PK	H	37.37	-6.52	43.86	37.33	74.00	-36.67
	1781	PK	H	37.37	-4.04	42.35	38.32	74.00	-35.68
	6236	PK	H	36.82	8.25	40.28	48.53	74.00	-25.47
	10440	PK	H	35.73	20.59	30.11	50.70	74.00	-23.30
	1144	PK	V	37.28	-7.93	60.67	52.74	74.00	-21.26
	1209	PK	V	37.29	-7.83	48.73	40.90	74.00	-33.10
	1572	PK	V	37.37	-6.52	49.79	43.27	74.00	-30.73
	2144	PK	V	37.37	-1.64	48.32	46.67	74.00	-27.33
	3629	PK	V	37.32	1.61	50.00	51.61	74.00	-22.39
	6236	PK	V	36.82	8.25	46.44	54.69	74.00	-19.31
	6236	AV	V	36.82	8.25	37.07	45.32	54.00	-8.68
	10440	PK	V	35.73	20.59	26.13	46.72	74.00	-27.28
802.11a_Ch48	1144	PK	H	37.28	-7.93	50.79	42.85	74.00	-31.15
	1781	PK	H	37.37	-4.04	43.42	39.39	74.00	-34.61
	6280	PK	H	36.80	8.39	40.18	48.58	74.00	-25.42
	10480	PK	H	35.71	20.81	30.26	51.07	74.00	-22.93
	1144	PK	V	37.28	-7.93	61.40	53.47	74.00	-20.53
	1209	PK	V	37.29	-7.83	49.79	41.96	74.00	-32.04
	1572	PK	V	37.37	-6.52	50.89	44.37	74.00	-29.63
	1715	PK	V	37.37	-4.82	48.78	43.96	74.00	-30.04
	2716	PK	V	37.40	-1.03	41.84	40.81	74.00	-33.19
	3651	PK	V	37.31	1.68	45.20	46.89	74.00	-27.11
	6280	PK	V	36.80	8.39	47.14	55.53	74.00	-18.47
	6280	AV	V	36.80	8.39	35.46	43.85	54.00	-10.15
	10480	PK	V	35.71	20.81	26.77	47.58	74.00	-26.42

Remark: Correction Factor = Antenna Factor + Cable Loss + High Pass Filter Loss - Pre_Amplifier Gain

TEST REPORT

Chain1

Mode	Frequency (MHz)	Spectrum Analyzer Detector	Ant. Pol. (H/V)	Preamp. Gain (dB)	Correction Factor (dB/m)	Reading (dBμV)	Corrected Reading (dBμV/m)	Limit @ 3 m (dBμV/m)	Margin (dB)
802.11a_Ch52	1144	PK	H	37.28	-7.93	50.83	42.89	74.00	-31.11
	1781	PK	H	37.37	-4.04	42.98	38.94	74.00	-35.06
	6313	PK	H	36.79	8.50	39.42	47.92	74.00	-26.08
	10520	PK	H	35.70	21.01	29.20	50.21	74.00	-23.79
	1144	PK	V	37.28	-7.93	62.39	54.46	74.00	-19.54
	1144	AV	V	37.28	-7.93	53.51	45.58	54.00	-8.42
	1209	PK	V	37.29	-7.83	47.19	39.35	74.00	-34.65
	1572	PK	V	37.37	-6.52	50.45	43.93	74.00	-30.07
	1781	PK	V	37.37	-4.04	46.86	42.82	74.00	-31.18
	2364	PK	V	37.37	-1.97	43.72	41.76	74.00	-32.24
	3684	PK	V	37.31	1.80	43.30	45.10	74.00	-28.90
	6324	PK	V	36.78	8.54	44.95	53.49	74.00	-20.51
	10520	PK	V	35.70	21.01	25.68	46.69	74.00	-27.31
802.11a_Ch60	1144	PK	H	37.28	-7.93	50.74	42.80	74.00	-31.20
	1572	PK	H	37.37	-6.52	44.43	37.90	74.00	-36.10
	1781	PK	H	37.37	-4.04	43.01	38.98	74.00	-35.02
	6401	PK	H	36.76	8.80	39.32	48.12	74.00	-25.88
	10600	PK	H	35.71	21.36	28.19	49.55	74.00	-24.45
	1144	PK	V	37.28	-7.93	62.43	54.49	74.00	-19.51
	1144	AV	V	37.28	-7.93	54.62	46.69	54.00	-7.31
	1209	PK	V	37.29	-7.83	49.63	41.79	74.00	-32.21
	1572	PK	V	37.37	-6.52	50.42	43.89	74.00	-30.11
	2144	PK	V	37.37	-1.64	47.46	45.81	74.00	-28.19
	6401	PK	V	36.76	8.80	46.93	55.72	74.00	-18.28
	6401	AV	V	36.76	8.80	33.51	42.31	54.00	-11.69
	10600	PK	V	35.71	21.36	24.60	45.96	74.00	-28.04
802.11a_Ch64	1144	PK	H	37.28	-7.93	50.17	42.24	74.00	-31.76
	1572	PK	H	37.37	-6.52	43.89	37.37	74.00	-36.63
	1858	PK	H	37.37	-3.12	42.21	39.09	74.00	-34.91
	6445	PK	H	36.74	8.94	42.00	50.94	74.00	-23.06
	10640	PK	H	35.71	21.54	27.43	48.97	74.00	-25.03
	1144	PK	V	37.28	-7.93	63.52	55.59	74.00	-18.41
	1144	AV	V	37.28	-7.93	54.69	46.76	54.00	-7.24
	1209	PK	V	37.29	-7.83	51.88	44.04	74.00	-29.96
	1572	PK	V	37.37	-6.52	50.08	43.56	74.00	-30.44
	1924	PK	V	37.37	-2.33	42.75	40.42	74.00	-33.58
	2144	PK	V	37.37	-1.64	44.11	42.47	74.00	-31.53
	6445	PK	V	36.74	8.94	48.39	57.33	74.00	-16.67
	6445	AV	V	36.74	8.94	35.37	44.31	54.00	-9.69
	10640	PK	V	35.71	21.54	24.42	45.95	74.00	-28.05

Remark: Correction Factor = Antenna Factor + Cable Loss + High Pass Filter Loss - Pre_Amplifier Gain

TEST REPORT

Chain1

Mode	Frequency (MHz)	Spectrum Analyzer Detector	Ant. Pol. (H/V)	Preamp. Gain (dB)	Correction Factor (dB/m)	Reading (dBμV)	Corrected Reading (dBμV/m)	Limit @ 3 m (dBμV/m)	Margin (dB)
802.11a_Ch100	1144	PK	H	37.28	-7.93	50.13	42.20	74.00	-31.80
	1572	PK	H	37.37	-6.52	43.90	37.38	74.00	-36.62
	1781	PK	H	37.37	-4.04	42.09	38.06	74.00	-35.94
	11000	PK	H	35.73	23.11	29.24	52.35	74.00	-21.65
	1144	PK	V	37.28	-7.93	63.32	55.39	74.00	-18.61
	1144	AV	V	37.28	-7.93	54.45	46.52	54.00	-7.48
	1209	PK	V	37.29	-7.83	48.64	40.81	74.00	-33.19
	1572	PK	V	37.37	-6.52	49.94	43.42	74.00	-30.58
	1781	PK	V	37.37	-4.04	45.09	41.05	74.00	-32.95
	2144	PK	V	37.37	-1.64	46.09	44.44	74.00	-29.56
	11000	PK	V	35.73	23.11	25.38	48.49	74.00	-25.51
802.11a_Ch120	1144	PK	H	37.28	-7.93	51.34	43.41	74.00	-30.59
	1352	PK	H	37.33	-7.61	43.50	35.89	74.00	-38.11
	1781	PK	H	37.37	-4.04	43.18	39.15	74.00	-34.85
	11200	PK	H	35.74	23.31	28.19	51.49	74.00	-22.51
	1144	PK	V	37.28	-7.93	64.89	56.95	74.00	-17.05
	1144	AV	V	37.28	-7.93	54.60	46.67	54.00	-7.33
	1209	PK	V	37.29	-7.83	50.72	42.89	74.00	-31.11
	1572	PK	V	37.37	-6.52	50.34	43.82	74.00	-30.18
	2144	PK	V	37.37	-1.64	46.28	44.64	74.00	-29.36
	2353	PK	V	37.37	-1.95	46.27	44.31	74.00	-29.69
	2716	PK	V	37.40	-1.03	43.34	42.31	74.00	-31.69
	4190	PK	V	37.25	3.31	42.72	46.03	74.00	-27.97
11200	PK	V	35.74	23.31	25.05	48.36	74.00	-25.64	
802.11a_Ch140	1144	PK	H	37.28	-7.93	54.04	46.10	74.00	-27.90
	1781	PK	H	37.37	-4.04	42.40	38.36	74.00	-35.64
	11400	PK	H	35.75	23.50	25.31	48.81	74.00	-25.19
	1144	PK	V	37.28	-7.93	60.32	52.39	74.00	-21.61
	1209	PK	V	37.29	-7.83	48.46	40.63	74.00	-33.37
	1572	PK	V	37.37	-6.52	50.07	43.55	74.00	-30.45
	1715	PK	V	37.37	-4.82	46.21	41.39	74.00	-32.61
	2144	PK	V	37.37	-1.64	43.28	41.64	74.00	-32.36
	2430	PK	V	37.37	-2.07	42.66	40.60	74.00	-33.40
	11400	PK	V	35.75	23.50	24.89	48.40	74.00	-25.60

Remark: Correction Factor = Antenna Factor + Cable Loss + High Pass Filter Loss - Pre_Amplifier Gain

TEST REPORT

Chain1

Mode	Frequency	Spectrum	Ant.	Preamp.	Correction	Reading	Corrected	Limit	Margin
	(MHz)	Analyzer Detector	Pol. (H/V)	Gain (dB)	Factor (dB/m)	(dBμV)	Reading (dBμV/m)	@ 3 m (dBμV/m)	(dB)
802.11a_Ch149	1144	PK	H	37.28	-7.93	55.42	47.49	74.00	-26.51
	11490	PK	H	35.76	23.59	25.44	49.03	74.00	-24.97
	1144	PK	V	37.28	-7.93	62.00	54.06	74.00	-19.94
	1144	AV	V	37.28	-7.93	54.16	46.23	54.00	-7.77
	1209	PK	V	37.29	-7.83	48.15	40.31	74.00	-33.69
	1572	PK	V	37.37	-6.52	50.18	43.65	74.00	-30.35
	1781	PK	V	37.37	-4.04	44.97	40.93	74.00	-33.07
	2144	PK	V	37.37	-1.64	43.93	42.29	74.00	-31.71
	2430	PK	V	37.37	-2.07	43.00	40.93	74.00	-33.07
	11490	PK	V	35.76	23.59	24.82	48.41	74.00	-25.59
802.11a_Ch157	1144	PK	H	37.28	-7.93	50.67	42.74	74.00	-31.26
	1715	PK	H	37.37	-4.82	45.91	41.08	74.00	-32.92
	11570	PK	H	35.74	23.47	24.98	48.46	74.00	-25.54
	1144	PK	V	37.28	-7.93	59.05	51.12	74.00	-22.88
	1209	PK	V	37.29	-7.83	48.39	40.56	74.00	-33.44
	1572	PK	V	37.37	-6.52	50.30	43.78	74.00	-30.22
	1715	PK	V	37.37	-4.82	45.23	40.41	74.00	-33.59
	2144	PK	V	37.37	-1.64	42.80	41.15	74.00	-32.85
802.11a_Ch165	1144	PK	H	37.28	-7.93	54.41	46.47	74.00	-27.53
	1858	PK	H	37.37	-3.12	42.69	39.58	74.00	-34.42
	11650	PK	H	35.72	23.32	24.31	47.64	74.00	-26.36
	1144	PK	V	37.28	-7.93	60.05	52.11	74.00	-21.89
	1209	PK	V	37.29	-7.83	52.82	44.99	74.00	-29.01
	1572	PK	V	37.37	-6.52	49.89	43.36	74.00	-30.64
	1715	PK	V	37.37	-4.82	45.75	40.93	74.00	-33.07
	1924	PK	V	37.37	-2.33	43.83	41.50	74.00	-32.50
	2144	PK	V	37.37	-1.64	43.61	41.97	74.00	-32.03
	11650	PK	V	35.72	23.32	24.26	47.58	74.00	-26.42

Remark: Correction Factor = Antenna Factor + Cable Loss + High Pass Filter Loss - Pre_Amplifier Gain

TEST REPORT

Chain0+1

Mode	Frequency (MHz)	Spectrum Analyzer Detector	Ant. Pol. (H/V)	Preamp. Gain (dB)	Correction Factor (dB/m)	Reading (dBμV)	Corrected Reading (dBμV/m)	Limit @ 3 m (dBμV/m)	Margin (dB)
802.11ac (VHT20) Ch36	1144	PK	H	37.28	-7.93	55.66	47.72	74.00	-26.28
	3574	PK	H	37.33	1.41	46.58	47.99	74.00	-26.01
	6170	PK	H	36.84	8.03	42.78	50.81	74.00	-23.19
	6478	PK	H	36.73	9.05	39.66	48.72	74.00	-25.28
	10360	PK	H	35.77	20.14	27.70	47.84	74.00	-26.16
	1144	PK	V	37.28	-7.93	62.79	54.86	74.00	-19.14
	1144	AV	V	37.28	-7.93	53.89	45.96	54.00	-8.04
	1209	PK	V	37.29	-7.83	53.97	46.14	74.00	-27.86
	1572	PK	V	37.37	-6.52	51.33	44.81	74.00	-29.19
	2144	PK	V	37.37	-1.64	46.04	44.39	74.00	-29.61
	3563	PK	V	37.33	1.37	57.91	59.28	74.00	-14.72
	3563	AV	V	37.33	1.37	41.84	43.21	54.00	-10.79
	6159	PK	V	36.84	7.99	46.64	54.63	74.00	-19.37
	6159	AV	V	36.84	7.99	36.48	44.47	54.00	-9.53
	6489	PK	V	36.72	9.09	46.50	55.59	74.00	-18.41
	6489	AV	V	36.72	9.09	32.74	41.83	54.00	-12.17
10360	PK	V	35.77	20.14	24.90	45.04	74.00	-28.96	
802.11ac (VHT20) Ch44	1144	PK	H	37.28	-7.93	50.53	42.60	74.00	-31.40
	3629	PK	H	37.32	1.61	42.49	44.09	74.00	-29.91
	6236	PK	H	36.82	8.25	42.17	50.42	74.00	-23.58
	10440	PK	H	35.73	20.59	28.45	49.04	74.00	-24.96
	1144	PK	V	37.28	-7.93	59.00	51.06	74.00	-22.94
	1209	PK	V	37.29	-7.83	48.36	40.53	74.00	-33.47
	1572	PK	V	37.37	-6.52	50.00	43.48	74.00	-30.52
	2144	PK	V	37.37	-1.64	45.00	43.36	74.00	-30.64
	3629	PK	V	37.32	1.61	50.77	52.38	74.00	-21.62
	6247	PK	V	36.81	8.28	47.00	55.29	74.00	-18.71
10440	PK	V	35.73	20.59	25.62	46.20	74.00	-27.80	
802.11ac (VHT20) Ch48	1144	PK	H	37.28	-7.93	49.04	41.11	74.00	-32.89
	1572	PK	H	37.37	-6.52	43.96	37.43	74.00	-36.57
	6280	PK	H	36.80	8.39	42.77	51.16	74.00	-22.84
	10480	PK	H	35.71	20.81	27.94	48.76	74.00	-25.24
	1144	PK	V	37.28	-7.93	62.53	54.59	74.00	-19.41
	1144	AV	V	37.28	-7.93	54.70	46.77	54.00	-7.23
	1209	PK	V	37.29	-7.83	52.14	44.30	74.00	-29.70
	1572	PK	V	37.37	-6.52	50.39	43.86	74.00	-30.14
	1781	PK	V	37.37	-4.04	45.15	41.11	74.00	-32.89
	3651	PK	V	37.31	1.68	47.02	48.71	74.00	-25.29
	6280	PK	V	36.80	8.39	45.09	53.48	74.00	-20.52
10480	PK	V	35.71	20.81	25.63	46.44	74.00	-27.56	

Remark: Correction Factor = Antenna Factor + Cable Loss + High Pass Filter Loss - Pre_Amplifier Gain

TEST REPORT

Chain0+1

Mode	Frequency (MHz)	Spectrum Analyzer Detector	Ant. Pol. (H/V)	Preamp. Gain (dB)	Correction Factor (dB/m)	Reading (dBμV)	Corrected Reading (dBμV/m)	Limit @ 3 m (dBμV/m)	Margin (dB)
802.11ac (VHT20) Ch52	1144	PK	H	37.28	-7.93	48.09	40.16	74.00	-33.84
	6313	PK	H	36.79	8.50	43.52	52.02	74.00	-21.98
	10520	PK	H	35.70	21.01	28.60	49.61	74.00	-24.39
	1144	PK	V	37.28	-7.93	54.20	46.26	74.00	-27.74
	1209	PK	V	37.29	-7.83	49.07	41.24	74.00	-32.76
	1572	PK	V	37.37	-6.52	49.64	43.11	74.00	-30.89
	2716	PK	V	37.40	-1.03	43.23	42.20	74.00	-31.80
	3684	PK	V	37.31	1.80	43.97	45.77	74.00	-28.23
	6313	PK	V	36.79	8.50	47.48	55.98	74.00	-18.02
	6313	AV	V	36.79	8.50	35.09	43.59	54.00	-10.41
10520	PK	V	35.70	21.01	25.43	46.44	74.00	-27.56	
802.11ac (VHT20) Ch60	1144	PK	H	37.28	-7.93	48.64	40.71	74.00	-33.29
	1572	PK	H	37.37	-6.52	44.20	37.68	74.00	-36.32
	2353	PK	H	37.37	-1.95	42.60	40.65	74.00	-33.35
	6390	PK	H	36.76	8.76	39.60	48.36	74.00	-25.64
	10600	PK	H	35.71	21.36	27.01	48.37	74.00	-25.63
	1144	PK	V	37.28	-7.93	60.58	52.65	74.00	-21.35
	1209	PK	V	37.29	-7.83	49.97	42.14	74.00	-31.86
	1572	PK	V	37.37	-6.52	49.70	43.17	74.00	-30.83
	2144	PK	V	37.37	-1.64	42.73	41.09	74.00	-32.91
	2716	PK	V	37.40	-1.03	44.19	43.16	74.00	-30.84
6401	PK	V	36.76	8.80	47.03	55.83	74.00	-18.17	
6401	AV	V	36.76	8.80	34.60	43.40	54.00	-10.60	
10600	PK	V	35.71	21.36	26.72	48.09	74.00	-25.91	
802.11ac (VHT20) Ch64	1143	PK	H	37.28	-7.94	47.91	39.97	74.00	-34.03
	1572	PK	H	37.37	-6.52	43.64	37.12	74.00	-36.88
	6445	PK	H	36.74	8.94	41.70	50.64	74.00	-23.36
	10640	PK	H	35.71	21.54	25.58	47.12	74.00	-26.88
	1144	PK	V	37.28	-7.93	61.44	53.51	74.00	-20.49
	1209	PK	V	37.29	-7.83	52.66	44.83	74.00	-29.17
	1572	PK	V	37.37	-6.52	49.92	43.40	74.00	-30.60
	2716	PK	V	37.40	-1.03	45.12	44.09	74.00	-29.91
	6445	PK	V	36.74	8.94	47.93	56.87	74.00	-17.13
6445	AV	V	36.74	8.94	34.99	43.93	54.00	-10.07	
802.11ac (VHT20) Ch100	1144	PK	H	37.28	-7.93	49.24	41.31	74.00	-32.69
	1715	PK	H	37.37	-4.82	43.24	38.42	74.00	-35.58
	11000	PK	H	35.73	23.11	28.43	51.54	74.00	-22.46
	1144	PK	V	37.28	-7.93	62.98	55.04	74.00	-18.96
	1144	AV	V	37.28	-7.93	54.62	46.69	54.00	-7.31
	1209	PK	V	37.29	-7.83	47.30	39.47	74.00	-34.53
	1572	PK	V	37.37	-6.52	50.16	43.64	74.00	-30.36
	2144	PK	V	37.37	-1.64	42.28	40.63	74.00	-33.37
	2716	PK	V	37.40	-1.03	41.53	40.50	74.00	-33.50
	11000	PK	V	35.73	23.11	25.81	48.92	74.00	-25.08

Remark: Correction Factor = Antenna Factor + Cable Loss + High Pass Filter Loss - Pre_Amplifier Gain

TEST REPORT

Chain0+1

Mode	Frequency (MHz)	Spectrum Analyzer Detector	Ant. Pol. (H/V)	Preamp. Gain (dB)	Correction Factor (dB/m)	Reading (dBμV)	Corrected Reading (dBμV/m)	Limit @ 3 m (dBμV/m)	Margin (dB)
802.11ac (VHT20) Ch120	1144	PK	H	37.28	-7.93	49.89	41.96	74.00	-32.04
	1572	PK	H	37.37	-6.52	44.95	38.42	74.00	-35.58
	11200	PK	H	35.74	23.31	27.18	50.49	74.00	-23.51
	1144	PK	V	37.28	-7.93	60.72	52.79	74.00	-21.21
	1572	PK	V	37.37	-6.52	49.87	43.35	74.00	-30.65
	1924	PK	V	37.37	-2.33	42.78	40.45	74.00	-33.55
	2430	PK	V	37.37	-2.07	42.52	40.45	74.00	-33.55
	4201	PK	V	37.25	3.34	46.10	49.44	74.00	-24.56
	11200	PK	V	35.74	23.31	24.77	48.08	74.00	-25.92
802.11ac (VHT20) Ch140	1144	PK	H	37.28	-7.93	49.18	41.25	74.00	-32.75
	1572	PK	H	37.37	-6.52	45.77	39.24	74.00	-34.76
	2353	PK	H	37.37	-1.95	40.23	38.28	74.00	-35.72
	11400	PK	H	35.75	23.50	25.28	48.78	74.00	-25.22
	1144	PK	V	37.28	-7.93	60.04	52.10	74.00	-21.90
	1572	PK	V	37.37	-6.52	50.72	44.20	74.00	-29.80
	1858	PK	V	37.37	-3.12	44.14	41.02	74.00	-32.98
	2716	PK	V	37.40	-1.03	45.66	44.63	74.00	-29.37
	4344	PK	V	37.24	3.63	38.94	42.56	74.00	-31.44
11400	PK	V	35.75	23.50	24.53	48.04	74.00	-25.96	
802.11ac (VHT20) Ch149	1144	PK	H	37.28	-7.93	49.49	41.55	74.00	-32.45
	1572	PK	H	37.37	-6.52	44.53	38.01	74.00	-35.99
	11490	PK	H	35.76	23.59	24.65	48.25	74.00	-25.75
	1144	PK	V	37.28	-7.93	62.12	54.19	74.00	-19.81
	1144	AV	V	37.28	-7.93	54.58	46.65	54.00	-7.35
	1209	PK	V	37.29	-7.83	49.76	41.92	74.00	-32.08
	1572	PK	V	37.37	-6.52	50.40	43.88	74.00	-30.12
	2144	PK	V	37.37	-1.64	47.09	45.45	74.00	-28.55
	4421	PK	V	37.24	3.79	43.38	47.16	74.00	-26.84
11490	PK	V	35.76	23.59	24.02	47.61	74.00	-26.39	
802.11ac (VHT20) Ch157	1144	PK	H	37.28	-7.93	50.34	42.41	74.00	-31.59
	1572	PK	H	37.37	-6.52	44.88	38.35	74.00	-35.65
	11570	PK	H	35.74	23.47	24.42	47.89	74.00	-26.11
	1144	PK	V	37.28	-7.93	61.46	53.53	74.00	-20.47
	1209	PK	V	37.29	-7.83	53.32	45.48	74.00	-28.52
	1572	PK	V	37.37	-6.52	50.08	43.56	74.00	-30.44
	1781	PK	V	37.37	-4.04	47.45	43.41	74.00	-30.59
	4476	PK	V	37.24	3.90	40.54	44.44	74.00	-29.56
	6324	PK	V	36.78	8.54	39.32	47.86	74.00	-26.14
11570	PK	V	35.74	23.47	23.98	47.45	74.00	-26.55	

Remark: Correction Factor = Antenna Factor + Cable Loss + High Pass Filter Loss - Pre_Amplifier Gain

TEST REPORT

Chain0+1

Mode	Frequency (MHz)	Spectrum Analyzer Detector	Ant. Pol. (H/V)	Preamp. Gain (dB)	Correction Factor (dB/m)	Reading (dBμV)	Corrected Reading (dBμV/m)	Limit @ 3 m (dBμV/m)	Margin (dB)
802.11ac (VHT20) Ch165	1144	PK	H	37.28	-7.93	52.79	44.86	74.00	-29.14
	1572	PK	H	37.37	-6.52	44.60	38.08	74.00	-35.92
	2353	PK	H	37.37	-1.95	42.48	40.52	74.00	-33.48
	11650	PK	H	35.72	23.32	23.65	46.97	74.00	-27.03
	1144	PK	V	37.28	-7.93	62.11	54.18	74.00	-19.82
	1144	AV	V	37.28	-7.93	54.33	46.40	54.00	-7.60
	1572	PK	V	37.37	-6.52	50.34	43.82	74.00	-30.18
	2067	PK	V	37.37	-1.53	42.74	41.21	74.00	-32.79
	2716	PK	V	37.40	-1.03	41.60	40.56	74.00	-33.44
	4531	PK	V	37.23	4.05	41.51	45.56	74.00	-28.44
	11650	PK	V	35.72	23.32	23.75	47.08	74.00	-26.92
802.11ac (VHT40) Ch38	1144	PK	H	37.28	-7.93	54.66	46.73	74.00	-27.27
	3585	PK	H	37.32	1.45	42.84	44.29	74.00	-29.71
	6181	PK	H	36.83	8.06	38.63	46.70	74.00	-27.30
	10380	PK	H	35.76	20.25	26.09	46.34	74.00	-27.66
	1144	PK	V	37.28	-7.93	61.46	53.52	74.00	-20.48
	1209	PK	V	37.29	-7.83	51.10	43.27	74.00	-30.73
	1572	PK	V	37.37	-6.52	50.28	43.76	74.00	-30.24
	1781	PK	V	37.37	-4.04	47.32	43.28	74.00	-30.72
	2144	PK	V	37.37	-1.64	44.98	43.34	74.00	-30.66
	3585	PK	V	37.32	1.45	50.80	52.25	74.00	-21.75
	6181	PK	V	36.83	8.06	45.55	53.61	74.00	-20.39
	6500	PK	V	36.72	9.13	41.49	50.61	74.00	-23.39
	10380	PK	V	35.76	20.25	24.69	44.94	74.00	-29.06
802.11ac (VHT40) Ch46	1144	PK	H	37.28	-7.93	53.89	45.95	74.00	-28.05
	6258	PK	H	36.81	8.32	37.80	46.12	74.00	-27.88
	10460	PK	H	35.72	20.70	26.76	47.46	74.00	-26.54
	1144	PK	V	37.28	-7.93	63.48	55.55	74.00	-18.45
	1144	AV	V	37.28	-7.93	54.69	46.76	54.00	-7.24
	1209	PK	V	37.29	-7.83	51.06	43.23	74.00	-30.77
	1572	PK	V	37.37	-6.52	50.19	43.67	74.00	-30.33
	1715	PK	V	37.37	-4.82	49.61	44.79	74.00	-29.21
	3640	PK	V	37.31	1.65	46.04	47.68	74.00	-26.32
	6269	PK	V	36.80	8.36	44.20	52.55	74.00	-21.45
	10460	PK	V	35.72	20.70	26.20	46.90	74.00	-27.10

Remark: Correction Factor = Antenna Factor + Cable Loss + High Pass Filter Loss - Pre_Amplifier Gain

TEST REPORT

Chain0+1

Mode	Frequency (MHz)	Spectrum Analyzer Detector	Ant. Pol. (H/V)	Preamp. Gain (dB)	Correction Factor (dB/m)	Reading (dBμV)	Corrected Reading (dBμV/m)	Limit @ 3 m (dBμV/m)	Margin (dB)
802.11ac (VHT40) Ch54	1144	PK	H	37.28	-7.93	55.93	48.00	74.00	-26.00
	1715	PK	H	37.37	-4.82	45.51	40.69	74.00	-33.31
	6346	PK	H	36.78	8.61	36.89	45.50	74.00	-28.50
	10540	PK	H	35.70	21.10	28.16	49.26	74.00	-24.74
	1144	PK	V	37.28	-7.93	61.53	53.59	74.00	-20.41
	1209	PK	V	37.29	-7.83	50.17	42.34	74.00	-31.66
	1572	PK	V	37.37	-6.52	50.08	43.55	74.00	-30.45
	1781	PK	V	37.37	-4.04	46.33	42.29	74.00	-31.71
	3706	PK	V	37.30	1.88	39.68	41.57	74.00	-32.43
	6335	PK	V	36.78	8.58	42.72	51.30	74.00	-22.70
	10540	PK	V	35.70	21.10	26.02	47.12	74.00	-26.88
802.11ac (VHT40) Ch62	1144	PK	H	37.28	-7.93	51.41	43.48	74.00	-30.52
	1715	PK	H	37.37	-4.82	43.34	38.52	74.00	-35.48
	6423	PK	H	36.75	8.87	38.41	47.28	74.00	-26.72
	10620	PK	H	35.71	21.45	26.61	48.06	74.00	-25.94
	1144	PK	V	37.28	-7.93	62.94	55.01	74.00	-18.99
	1144	AV	V	37.28	-7.93	54.27	46.34	54.00	-7.66
	1209	PK	V	37.29	-7.83	49.46	41.63	74.00	-32.37
	1572	PK	V	37.37	-6.52	49.71	43.18	74.00	-30.82
	2144	PK	V	37.37	-1.64	45.59	43.94	74.00	-30.06
	2716	PK	V	37.40	-1.03	45.03	44.00	74.00	-30.00
	6423	PK	V	36.75	8.87	44.53	53.40	74.00	-20.60
10620	PK	V	35.71	21.45	24.86	46.31	74.00	-27.69	
802.11ac (VHT40) Ch102	1144	PK	H	37.28	-7.93	52.79	44.86	74.00	-29.14
	1572	PK	H	37.37	-6.52	45.43	38.91	74.00	-35.09
	11020	PK	H	35.73	23.13	30.02	53.15	74.00	-20.85
	1144	PK	V	37.28	-7.93	62.38	54.45	74.00	-19.55
	1144	AV	V	37.28	-7.93	54.49	46.56	54.00	-7.44
	1209	PK	V	37.29	-7.83	52.64	44.80	74.00	-29.20
	1572	PK	V	37.37	-6.52	50.16	43.64	74.00	-30.36
	1715	PK	V	37.37	-4.82	45.75	40.93	74.00	-33.07
	2144	PK	V	37.37	-1.64	43.25	41.61	74.00	-32.39
	2716	PK	V	37.40	-1.03	43.09	42.06	74.00	-31.94
	11020	PK	V	35.73	23.13	26.40	49.53	74.00	-24.47
802.11ac (VHT40) Ch118	1144	PK	H	37.28	-7.93	51.45	43.51	74.00	-30.49
	1572	PK	H	37.37	-6.52	44.66	38.13	74.00	-35.87
	11180	PK	H	35.74	23.29	27.71	51.00	74.00	-23.00
	1144	PK	V	37.28	-7.93	57.55	49.62	74.00	-24.38
	1209	PK	V	37.29	-7.83	48.31	40.48	74.00	-33.52
	1572	PK	V	37.37	-6.52	50.81	44.29	74.00	-29.71
	1715	PK	V	37.37	-4.82	51.42	46.60	74.00	-27.40
	1924	PK	V	37.37	-2.33	43.61	41.27	74.00	-32.73
	4179	PK	V	37.25	3.29	41.86	45.15	74.00	-28.85
	11180	PK	V	35.74	23.29	24.88	48.17	74.00	-25.83

TEST REPORT

Chain0+1

Mode	Frequency (MHz)	Spectrum Analyzer Detector	Ant. Pol. (H/V)	Preamp. Gain (dB)	Correction Factor (dB/m)	Reading (dBμV)	Corrected Reading (dBμV/m)	Limit @ 3 m (dBμV/m)	Margin (dB)
802.11ac (VHT40) Ch134	1144	PK	H	37.28	-7.93	50.43	42.50	74.00	-31.50
	11340	PK	H	35.75	23.45	25.31	48.75	74.00	-25.25
	1144	PK	V	37.28	-7.93	61.56	53.63	74.00	-20.37
	1209	PK	V	37.29	-7.83	52.79	44.96	74.00	-29.04
	1572	PK	V	37.37	-6.52	50.75	44.22	74.00	-29.78
	2144	PK	V	37.37	-1.64	46.23	44.58	74.00	-29.42
	2353	PK	V	37.37	-1.95	45.13	43.18	74.00	-30.82
	4300	PK	V	37.24	3.54	40.65	44.19	74.00	-29.81
	11340	PK	V	35.75	23.45	23.68	47.12	74.00	-26.88
802.11ac (VHT40) Ch151	1144	PK	H	37.28	-7.93	51.70	43.76	74.00	-30.24
	11510	PK	H	35.76	23.58	24.05	47.63	74.00	-26.37
	1144	PK	V	37.28	-7.93	58.49	50.56	74.00	-23.44
	1209	PK	V	37.29	-7.83	50.79	42.96	74.00	-31.04
	1572	PK	V	37.37	-6.52	49.76	43.23	74.00	-30.77
	1924	PK	V	37.37	-2.33	42.91	40.57	74.00	-33.43
	2716	PK	V	37.40	-1.03	44.98	43.94	74.00	-30.06
	4432	PK	V	37.24	3.81	38.37	42.18	74.00	-31.82
	11510	PK	V	35.76	23.58	24.64	48.23	74.00	-25.77
802.11ac (VHT40) Ch159	1144	PK	H	37.28	-7.93	55.50	47.57	74.00	-26.43
	11590	PK	H	35.74	23.44	23.93	47.36	74.00	-26.64
	1144	PK	V	37.28	-7.93	57.54	49.61	74.00	-24.39
	1209	PK	V	37.29	-7.83	49.97	42.13	74.00	-31.87
	1715	PK	V	37.37	-4.82	47.94	43.12	74.00	-30.88
	2430	PK	V	37.37	-2.07	43.00	40.93	74.00	-33.07
	4487	PK	V	37.24	3.92	38.59	42.51	74.00	-31.49
	11590	PK	V	35.74	23.44	24.25	47.69	74.00	-26.31

Remark: Correction Factor = Antenna Factor + Cable Loss + High Pass Filter Loss - Pre_Amplifier Gain

TEST REPORT

Chain0+1

Mode	Frequency (MHz)	Spectrum Analyzer Detector	Ant. Pol. (H/V)	Preamp. Gain (dB)	Correction Factor (dB/m)	Reading (dBμV)	Corrected Reading (dBμV/m)	Limit @ 3 m (dBμV/m)	Margin (dB)
802.11ac (VHT80) Ch42	1144	PK	H	37.28	-7.93	49.90	41.96	74.00	-32.04
	10420	PK	H	35.74	20.47	26.16	46.64	74.00	-27.36
	1144	PK	V	37.28	-7.93	55.62	47.69	74.00	-26.31
	1209	PK	V	37.29	-7.83	49.38	41.54	74.00	-32.46
	1572	PK	V	37.37	-6.52	49.65	43.13	74.00	-30.87
	2716	PK	V	37.40	-1.03	43.83	42.80	74.00	-31.20
	10420	PK	V	35.74	20.47	26.14	46.62	74.00	-27.38
802.11ac (VHT80) Ch58	1144	PK	H	37.28	-7.93	44.18	36.24	74.00	-37.76
	10580	PK	H	35.70	21.28	25.25	46.52	74.00	-27.48
	1144	PK	V	37.28	-7.93	50.93	43.00	74.00	-31.00
	1209	PK	V	37.29	-7.83	49.57	41.73	74.00	-32.27
	1572	PK	V	37.37	-6.52	49.89	43.37	74.00	-30.63
	2067	PK	V	37.37	-1.53	42.56	41.03	74.00	-32.97
	10580	PK	V	35.70	21.28	25.97	47.24	74.00	-26.76
802.11ac (VHT80) Ch106	1144	PK	H	37.28	-7.93	41.95	34.01	74.00	-39.99
	11060	PK	H	35.73	23.17	27.57	50.74	74.00	-23.26
	1144	PK	V	37.28	-7.93	51.52	43.59	74.00	-30.41
	1572	PK	V	37.37	-6.52	51.08	44.56	74.00	-29.44
	2067	PK	V	37.37	-1.53	42.83	41.30	74.00	-32.70
	2716	PK	V	37.40	-1.03	41.71	40.68	74.00	-33.32
	11060	PK	V	35.73	23.17	25.60	48.77	74.00	-25.23
802.11ac (VHT80) Ch126	1144	PK	H	37.28	-7.93	52.20	44.27	74.00	-29.73
	11220	PK	H	35.74	23.33	25.83	49.16	74.00	-24.84
	1144	PK	V	37.28	-7.93	61.18	53.24	74.00	-20.76
	1572	PK	V	37.37	-6.52	50.68	44.16	74.00	-29.84
	1924	PK	V	37.37	-2.33	43.33	41.00	74.00	-33.00
	2716	PK	V	37.40	-1.03	44.44	43.40	74.00	-30.60
	11220	PK	V	35.74	23.33	25.31	48.64	74.00	-25.36
802.11ac (VHT80) Ch156	1144	PK	H	37.28	-7.93	52.20	44.27	74.00	-29.73
	11550	PK	H	35.75	23.51	24.72	48.23	74.00	-25.77
	1144	PK	V	37.28	-7.93	62.45	54.52	74.00	-19.48
	1144	AV	V	37.28	-7.93	54.63	46.70	54.00	-7.30
	1209	PK	V	37.29	-7.83	48.40	40.57	74.00	-33.43
	1572	PK	V	37.37	-6.52	49.74	43.21	74.00	-30.79
	2144	PK	V	37.37	-1.64	43.73	42.09	74.00	-31.91
	2716	PK	V	37.40	-1.03	42.22	41.19	74.00	-32.81
	11550	PK	V	35.75	23.51	24.07	47.58	74.00	-26.42

Remark: Correction Factor = Antenna Factor + Cable Loss + High Pass Filter Loss - Pre_Amplifier Gain

6. Emission on The Band Edge

6.1 Operating environment

Temperature:	25	
Relative Humidity:	50	%
Atmospheric Pressure	1008	hPa
Requirement	15.407(b), 15.209	
Channel	36, 38, 42, 46, 48 149, 157, 165, 151, 159, 155	

6.2 Measuring instrument setting

Spectrum analyzer settings	
Spectrum Analyzer function	Setting
Detector	Peak
RBW	1MHz
VBW	3MHz for Peak; 10Hz for Average
Sweep	Auto couple
Restrict bands	4500~5150MHz
	5350 ~5460MHz
Attenuation	Auto

Applicable to	Limit	
	EIRP Limit (dBm)	Equivalent Field Strength at 3m (dBμV/m)
5715-5725MHz	PK	PK
5850-5860MHz	-17	78.2

6.3 Test procedure

The test procedure is the same as clause 5.4

6.4 Test Result

Mode	Frequency (MHz)	Spectrum Analyzer Detector	Ant. Pol. (H/V)	Preamp. Gain (dB)	Correction Factor (dB/m)	Reading (dBμV)	Corrected Reading (dBμV/m)	Limit @ 3 m (dBμV/m)	Margin (dB)	Restricted band (MHz)
802.11a Chain0	5150.00	PK	V	37.05	5.97	52.96	58.93	74	-15.07	4500~5150
	5150.00	AV	V	37.05	5.97	29.75	35.72	54	-18.28	
	5390.66	PK	V	37.00	6.30	37.07	43.37	74	-30.63	5350~5460
	5390.66	AV	V	37.00	6.30	27.75	34.05	54	-19.95	
802.11a Chain1	5150.00	PK	V	37.05	5.97	49.40	55.37	74	-18.63	4500~5150
	5150.00	AV	V	37.05	5.97	35.22	41.19	54	-12.81	
	5395.69	PK	V	37.00	6.31	40.87	47.18	74	-26.82	5350~5460
	5390.66	AV	V	37.00	6.30	29.96	36.26	54	-17.74	
802.11ac (VHT20) Chain0+1	5146.80	PK	V	37.05	5.96	58.44	64.40	74	-9.60	4500~5150
	5150.00	AV	V	37.05	5.97	36.45	42.42	54	-11.58	
	5450.60	PK	V	36.99	6.39	39.40	45.79	74	-28.21	5350~5460
	5389.22	AV	V	37.00	6.30	29.43	35.73	54	-18.27	
802.11ac (VHT40) Chain0+1	5150.00	PK	V	37.05	5.97	65.91	67.68	74	-6.32	4500~5150
	5150.00	AV	V	37.05	5.97	47.13	53.10	54	-0.90	
	5350.00	PK	V	37.01	6.25	39.76	46.01	74	-27.99	5350~5460
	5350.00	AV	V	37.01	6.25	27.60	33.85	54	-20.15	
802.11ac (VHT80) Chain0+1	5150.00	PK	V	37.05	5.97	58.74	64.71	74	-9.29	4500~5150
	5150.00	AV	V	37.05	5.97	42.78	48.75	54	-5.25	
	5356.23	PK	V	37.01	6.25	44.95	51.20	74	-22.80	5350~5460
	5350.00	AV	V	37.01	6.25	31.18	37.43	54	-16.57	

Remark: Correction Factor = Antenna Factor + Cable Loss

Chain0 : Restricted Band Bandedge @ 802.11a Mode Ch36 PK

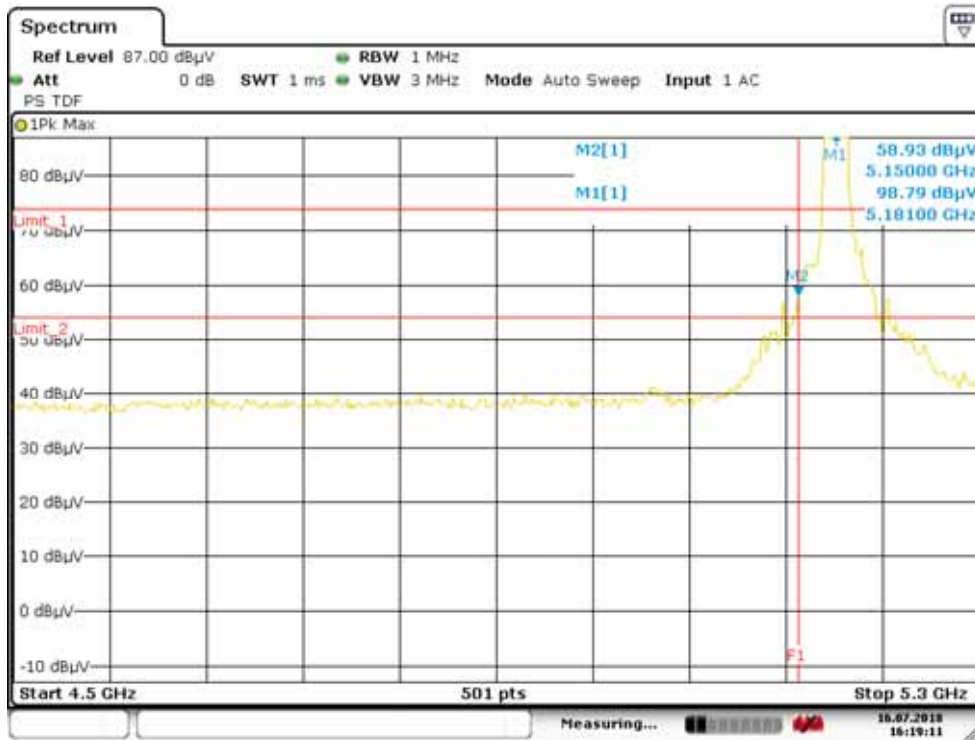

Date: 16.JUL.2018 16:19:11

Chain0 : Restricted Band Bandedge @ 802.11a Mode Ch36 AV

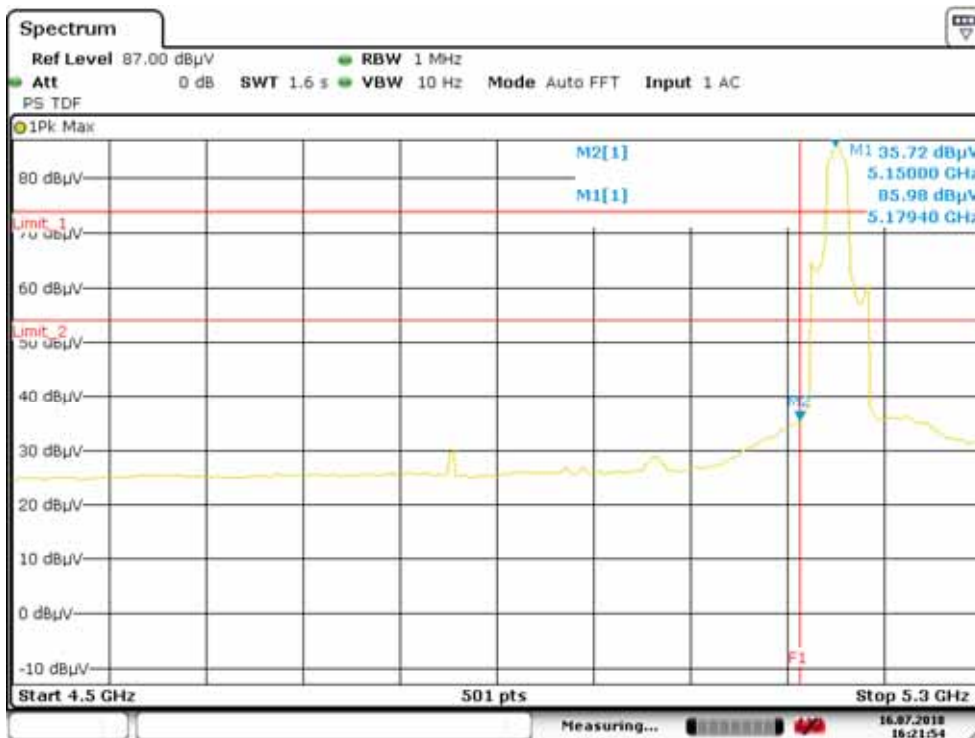

Date: 16.JUL.2018 16:21:54

Chain0 : Restricted Band Bandedge @ 802.11a Mode Ch48 PK

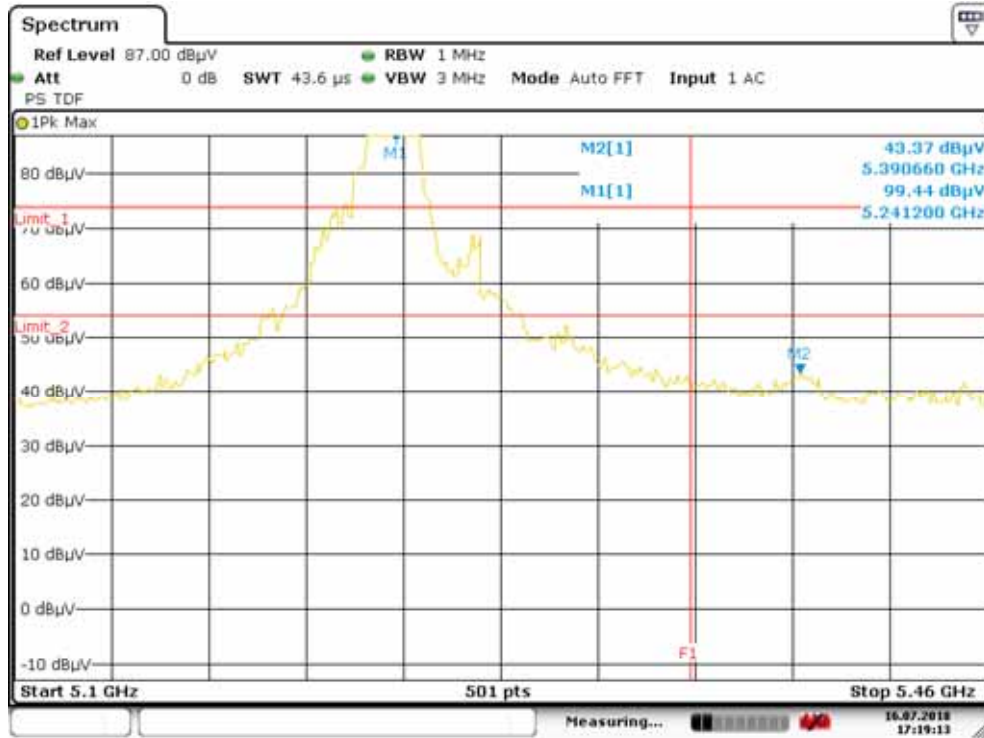

Date: 16.JUL.2018 17:19:13

Chain0 : Restricted Band Bandedge @ 802.11a Mode Ch48 AV

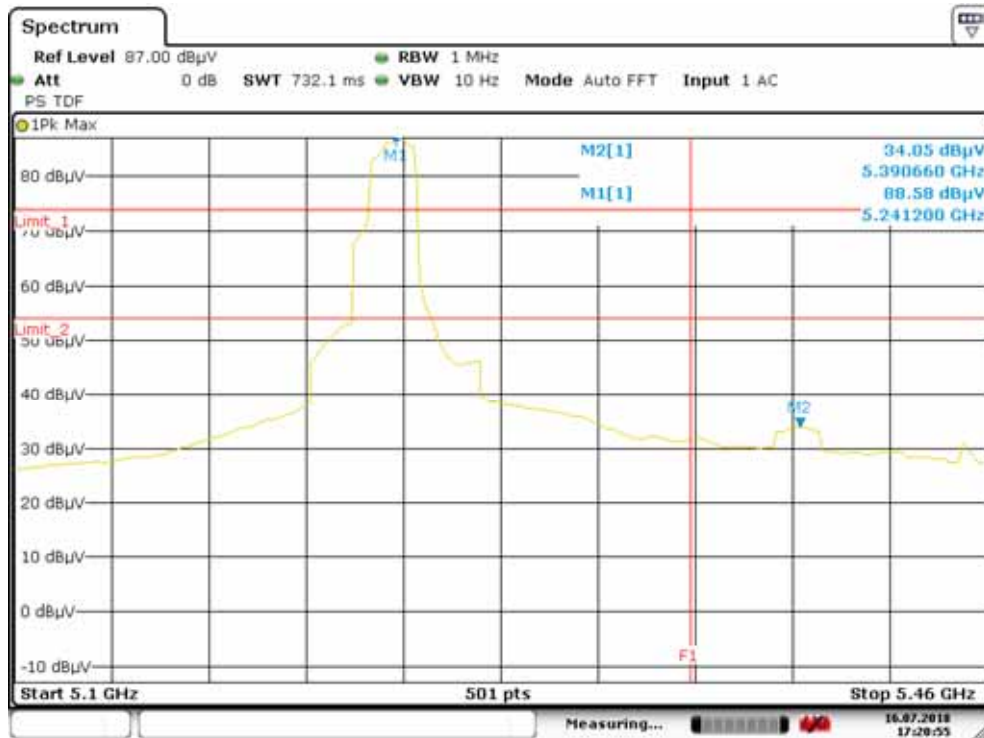

Date: 16.JUL.2018 17:20:55

Chain1 : Restricted Band Bandedge @ 802.11a Mode Ch36 PK

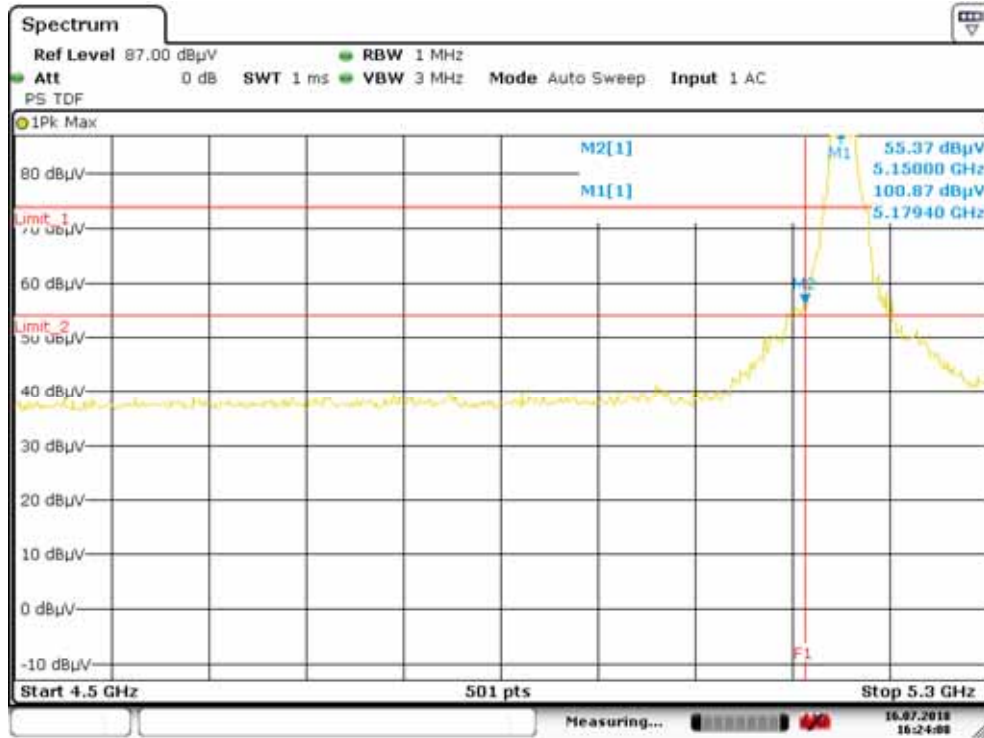

Date: 16.JUL.2018 16:24:08

Chain1 : Restricted Band Bandedge @ 802.11a Mode Ch36 AV

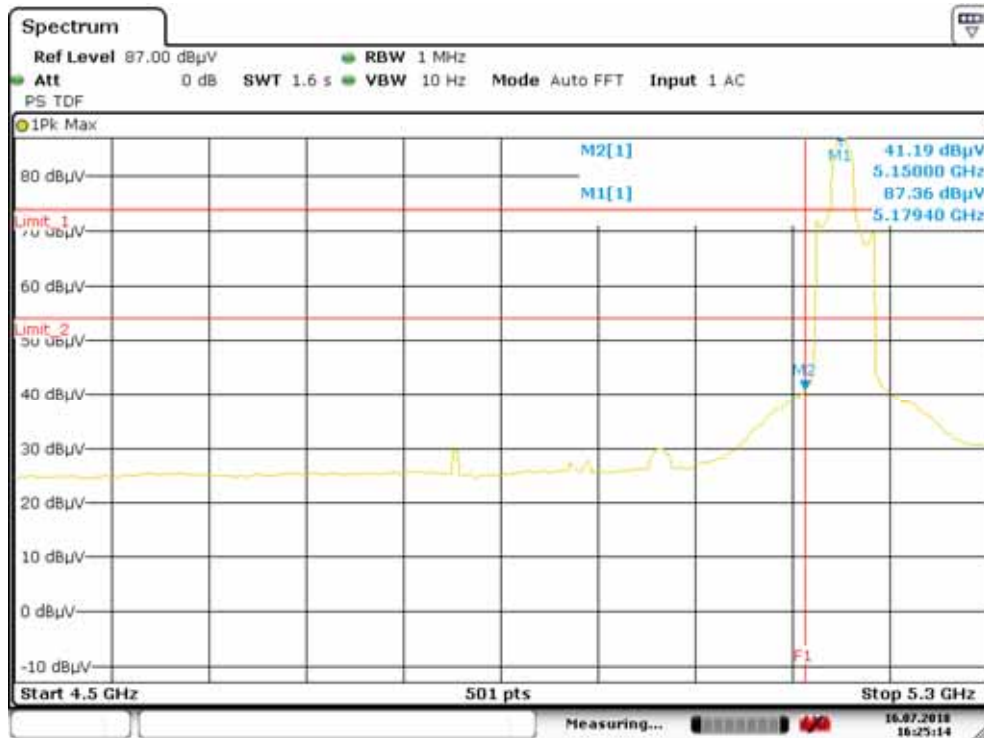

Date: 16.JUL.2018 16:25:14

Chain1 : Restricted Band Bandedge @ 802.11a Mode Ch48 PK

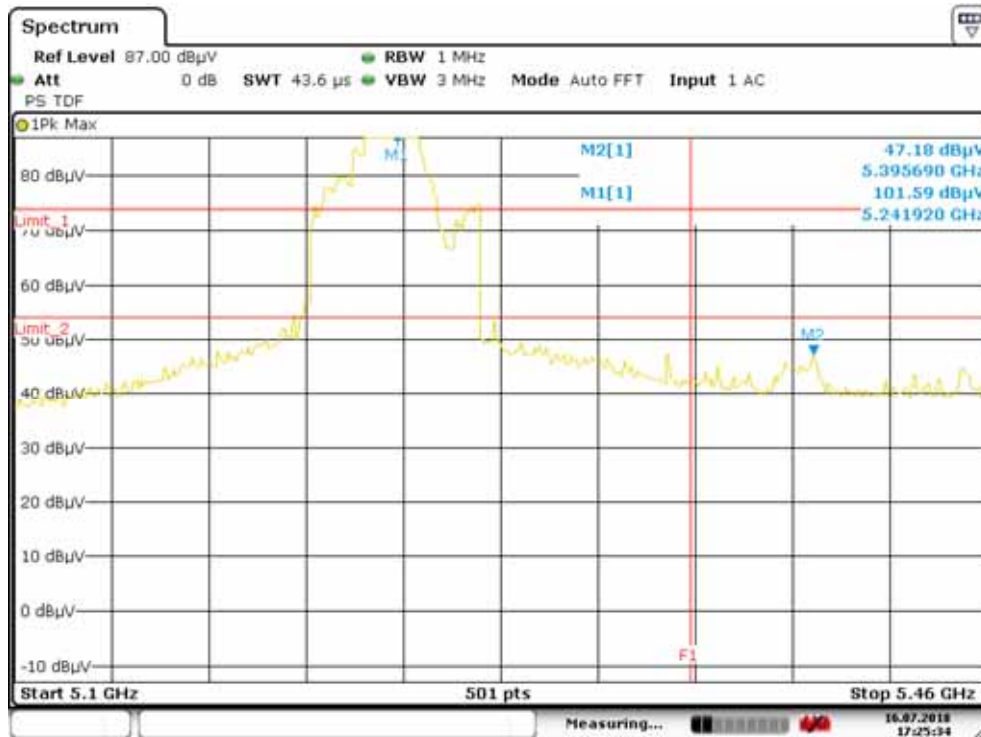

Date: 16.JUL.2018 17:25:34

Chain1 : Restricted Band Bandedge @ 802.11a Mode Ch48 AV

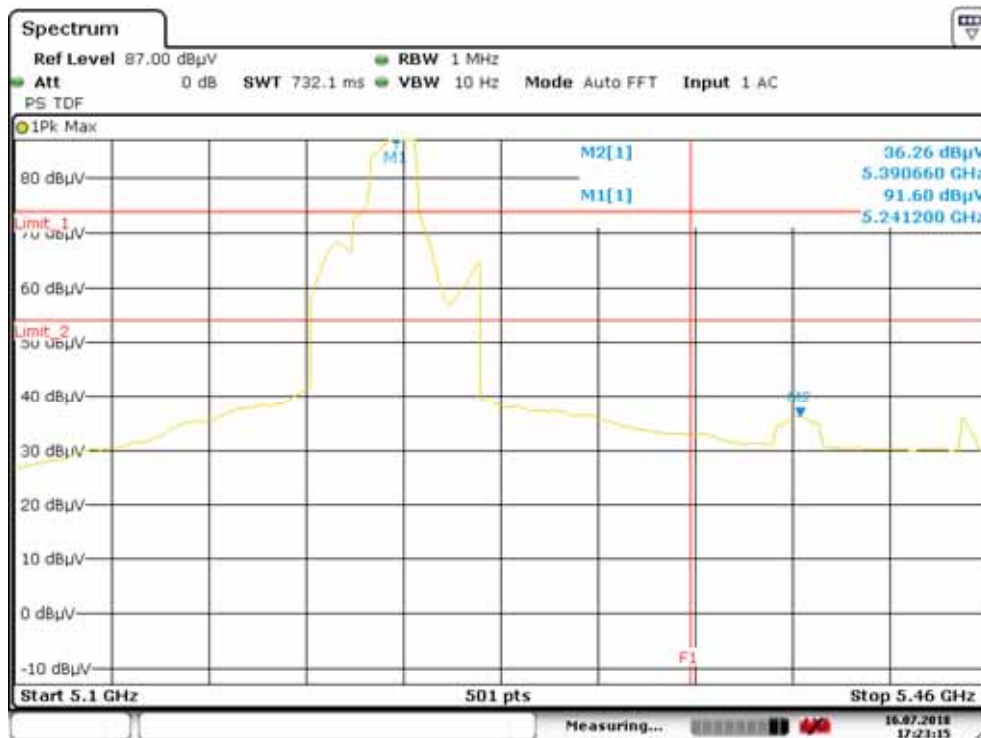

Date: 16.JUL.2018 17:23:15

Chain0+1 : Restricted Band Bandedge @ 802.11ac(VHT20) Mode Ch36 PK

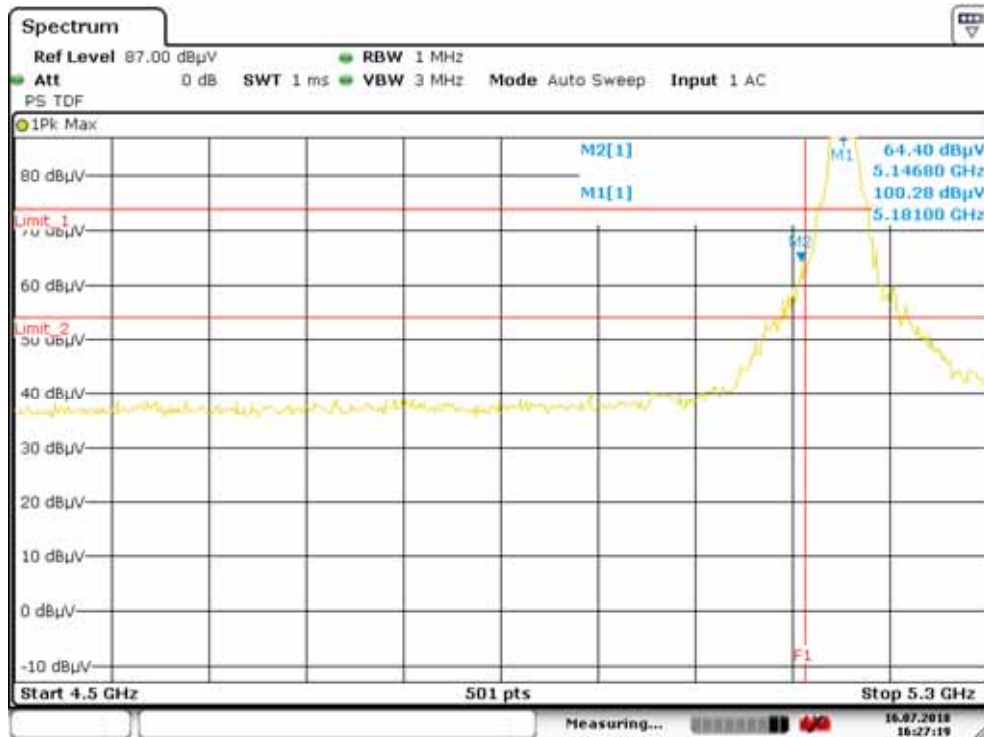

Date: 16.JUL.2018 16:27:19

Chain0+1 : Restricted Band Bandedge @ 802.11ac(VHT20) Mode Ch36 AV

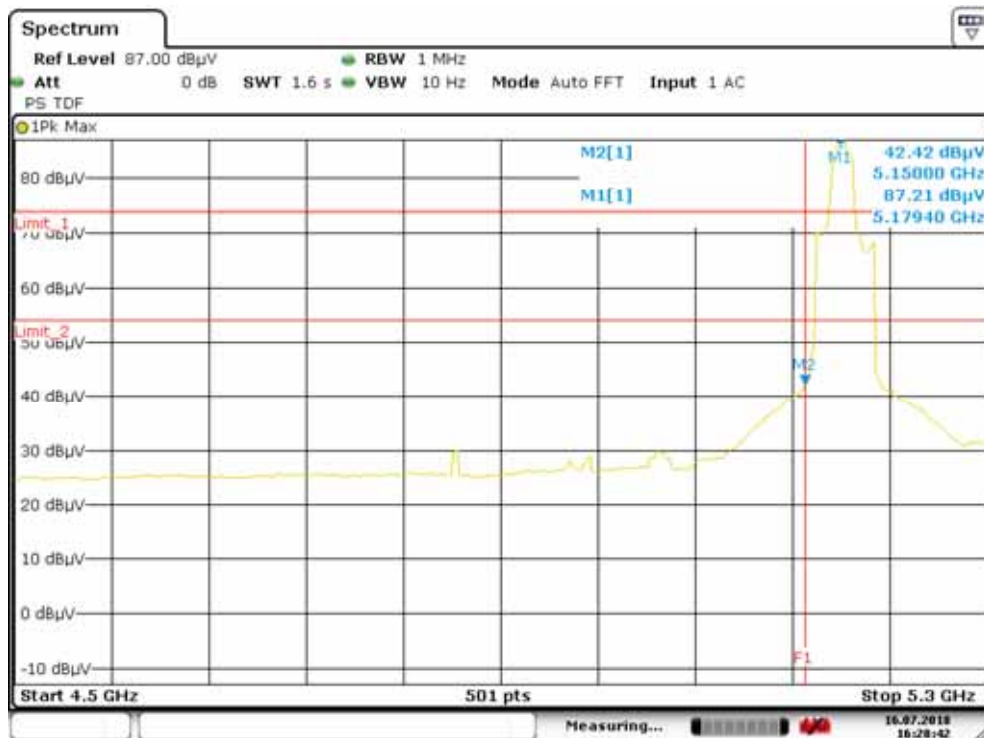

Date: 16.JUL.2018 16:28:42

Chain0+1 : Restricted Band Bandedge @ 802.11ac(VHT20) Mode Ch48 PK

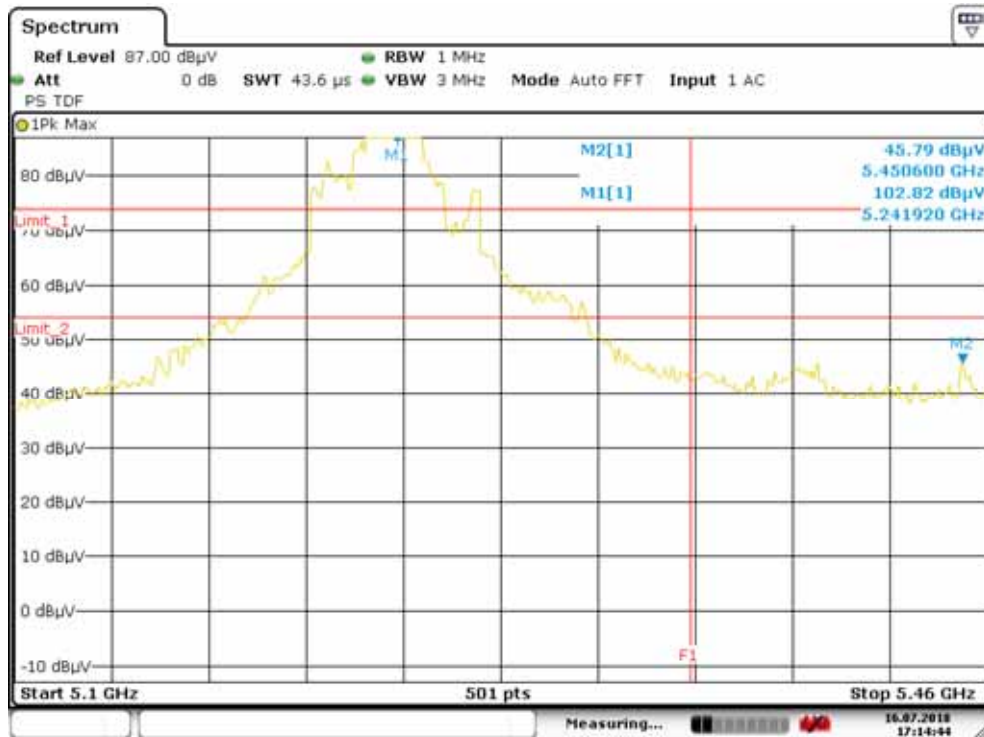

Date: 16.JUL.2018 17:14:44

Chain0+1 : Restricted Band Bandedge @ 802.11ac(VHT20) Mode Ch48 AV

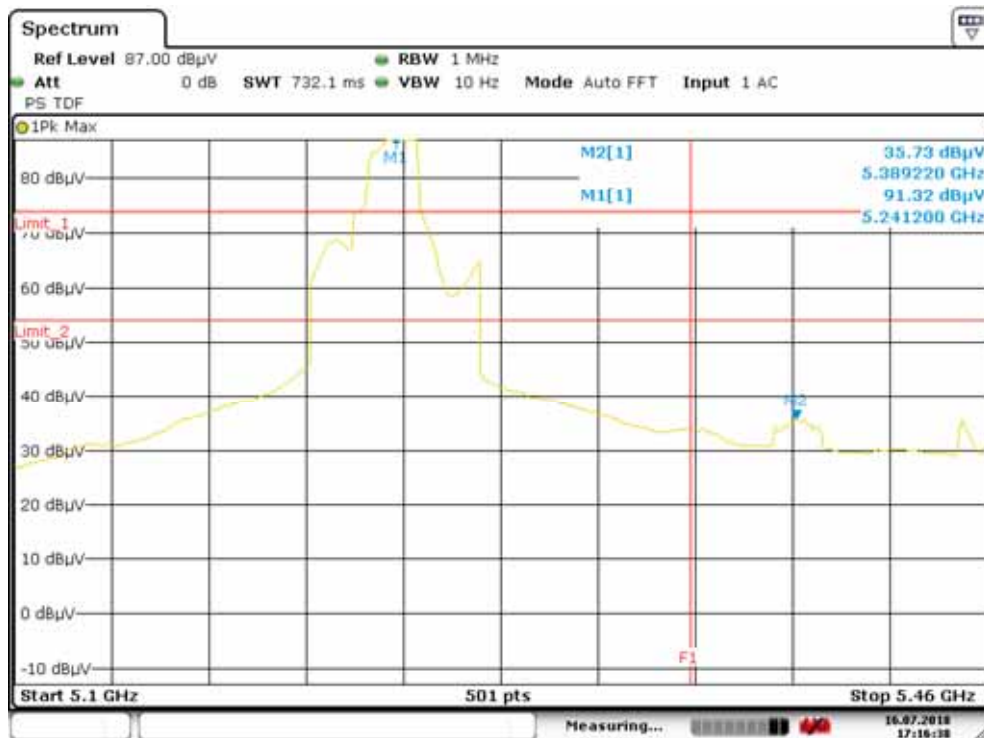

Date: 16.JUL.2018 17:16:38

Chain0+1 : Restricted Band Bandedge @ 802.11ac(VHT40) Mode Ch38 PK

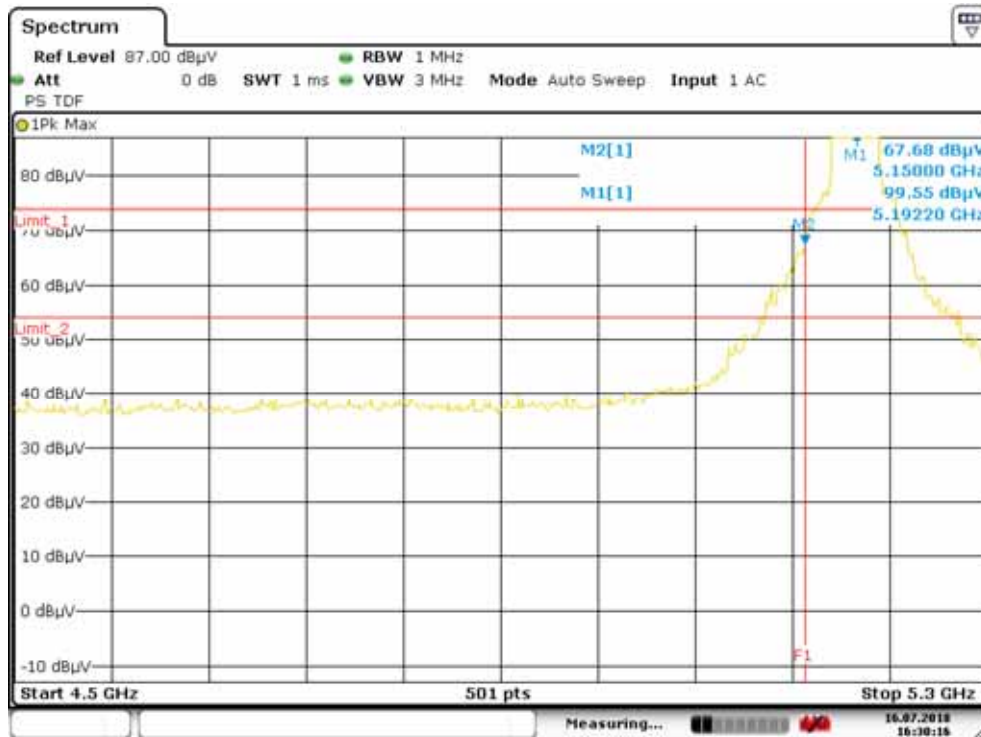

Date: 16.JUL.2018 16:30:15

Chain0+1 : Restricted Band Bandedge @ 802.11ac(VHT40) Mode Ch38 AV

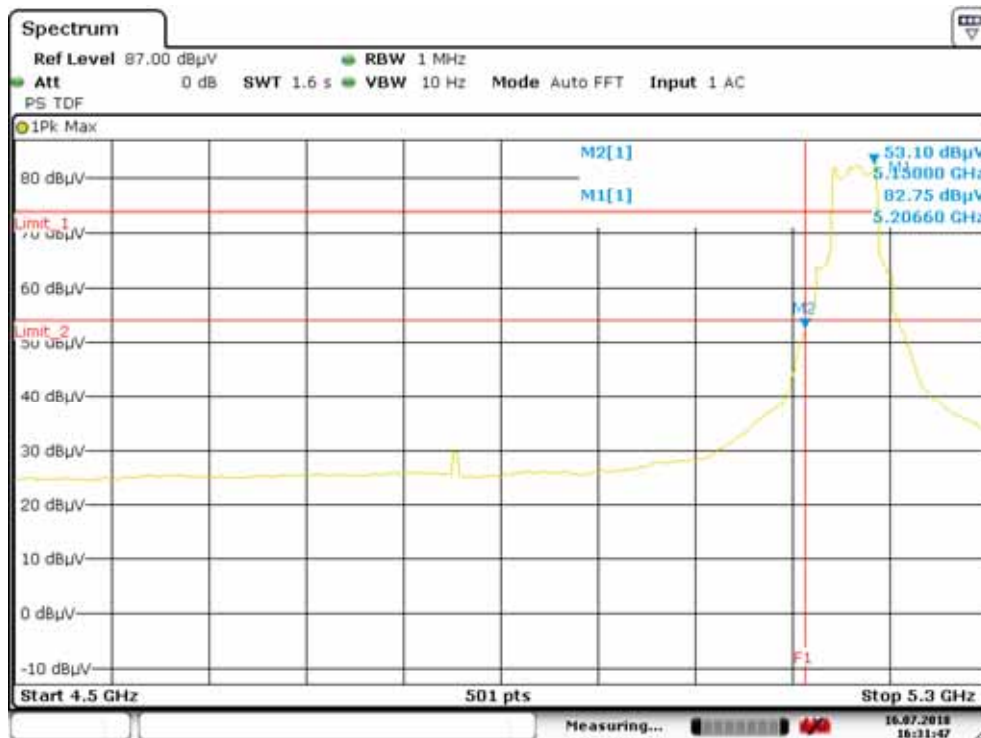

Date: 16.JUL.2018 16:31:47

Chain0+1 : Restricted Band Bandedge @ 802.11ac(VHT40) Mode Ch46 PK

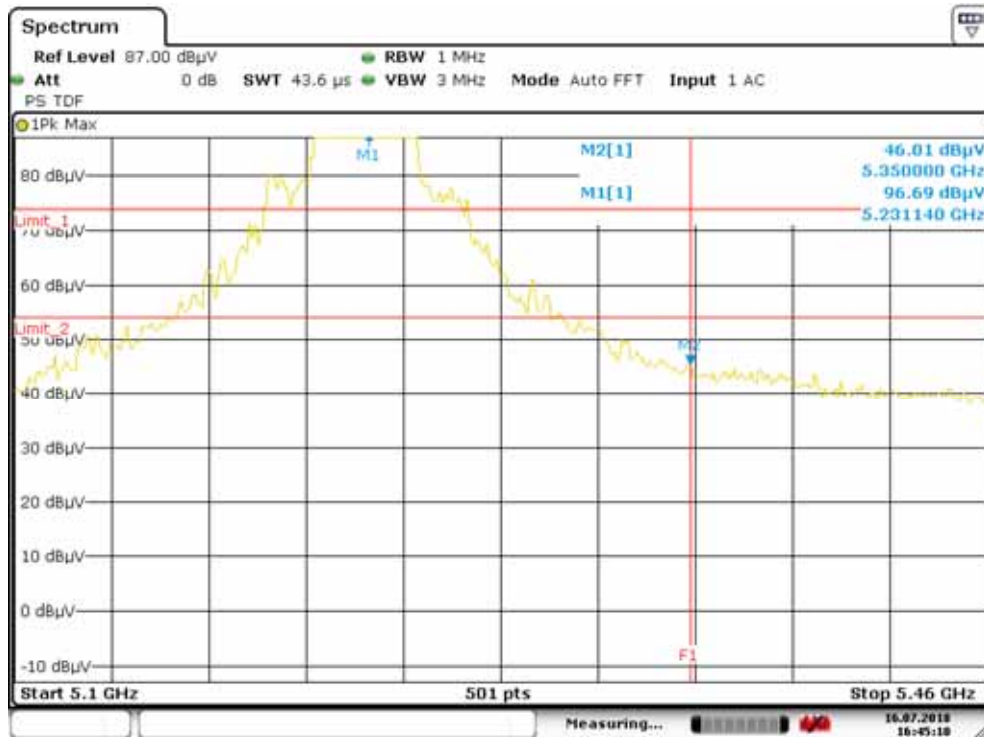

Date: 16.JUL.2018 16:45:10

Chain0+1 : Restricted Band Bandedge @ 802.11ac(VHT40) Mode Ch46 AV

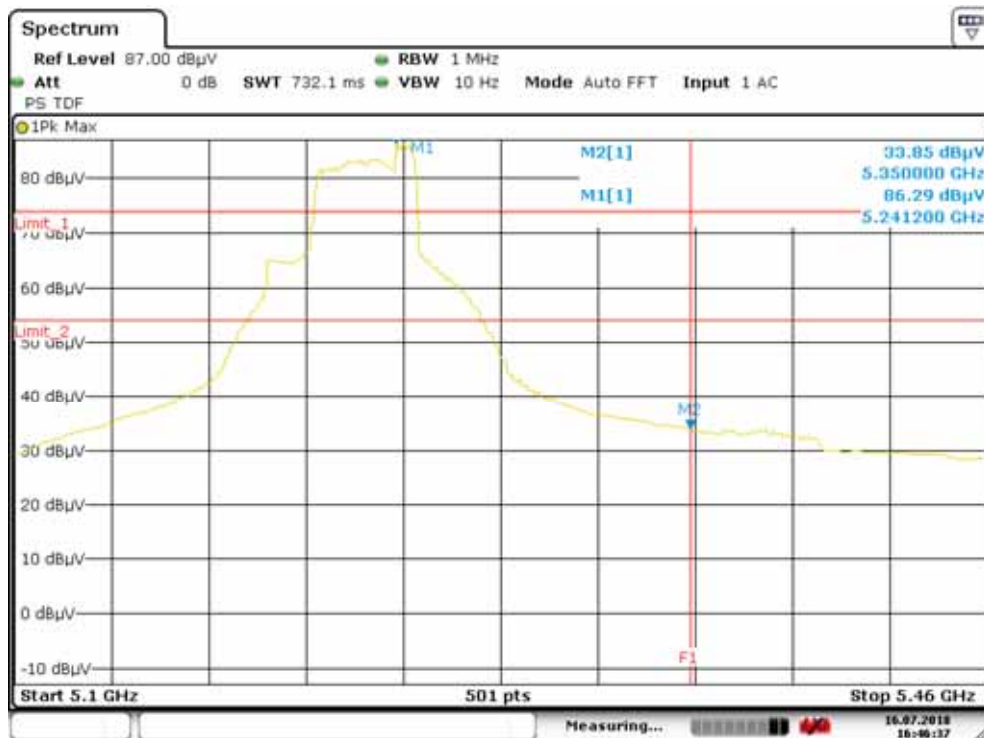

Date: 16.JUL.2018 16:46:37

Chain0+1 : Restricted Band Bandedge @ 802.11ac(VHT80) Mode Ch42 Lower PK

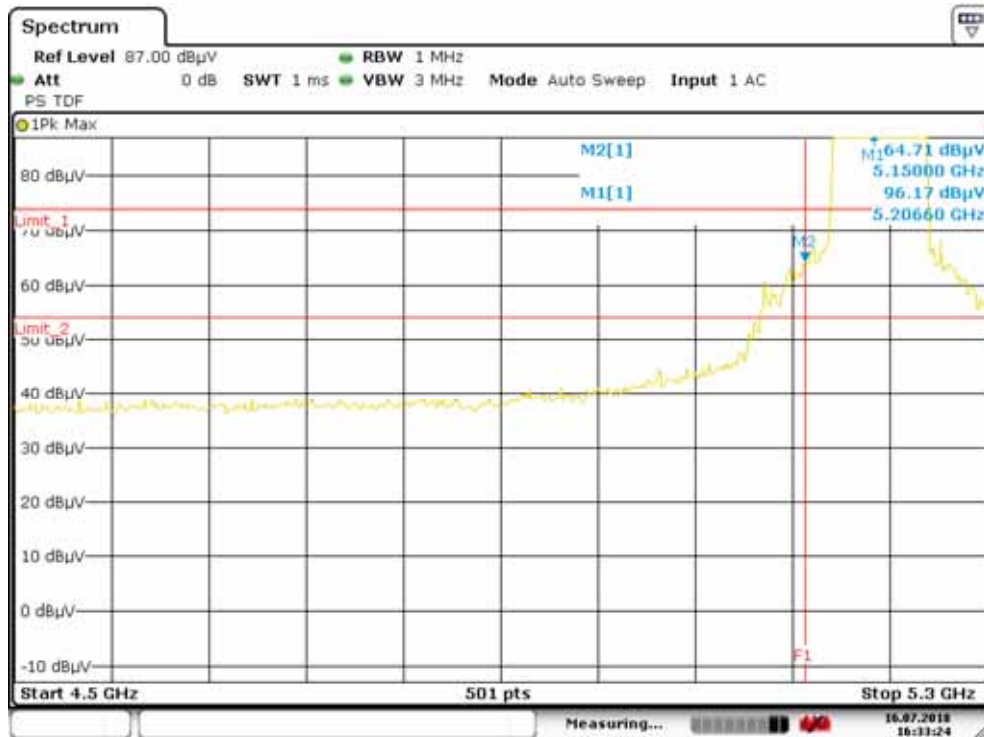

Date: 16.JUL.2018 16:33:24

Chain0+1 : Restricted Band Bandedge @ 802.11ac(VHT80) Mode Ch42 Lower AV

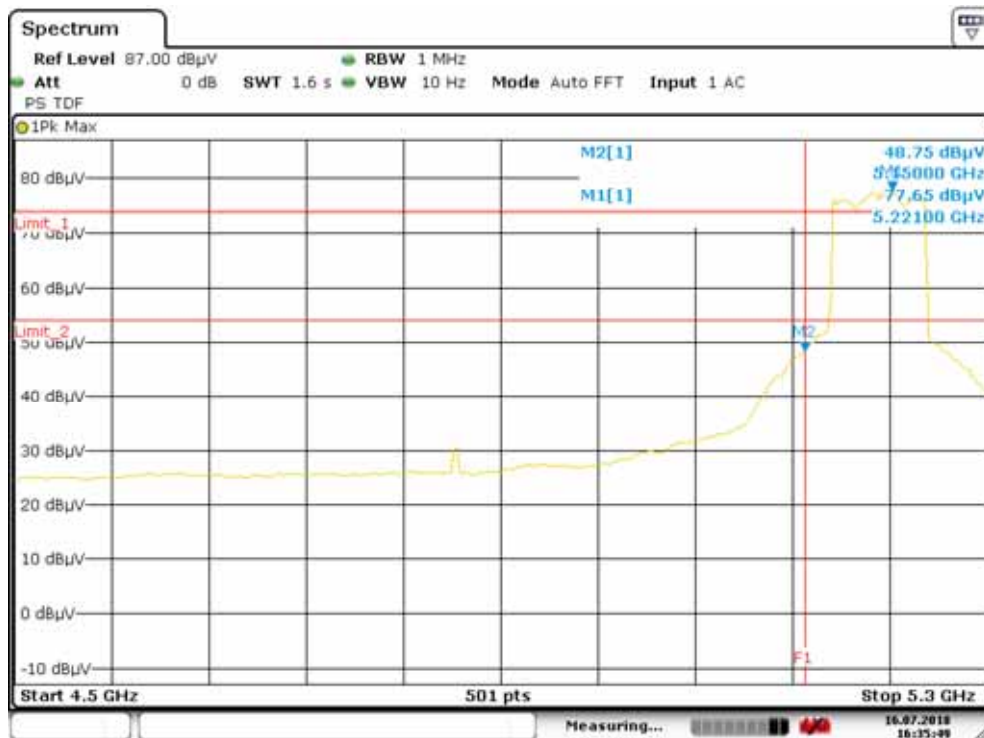

Date: 16.JUL.2018 16:35:49

Chain0+1 : Restricted Band Bandedge @ 802.11ac(VHT80) Mode Ch42 Upper PK

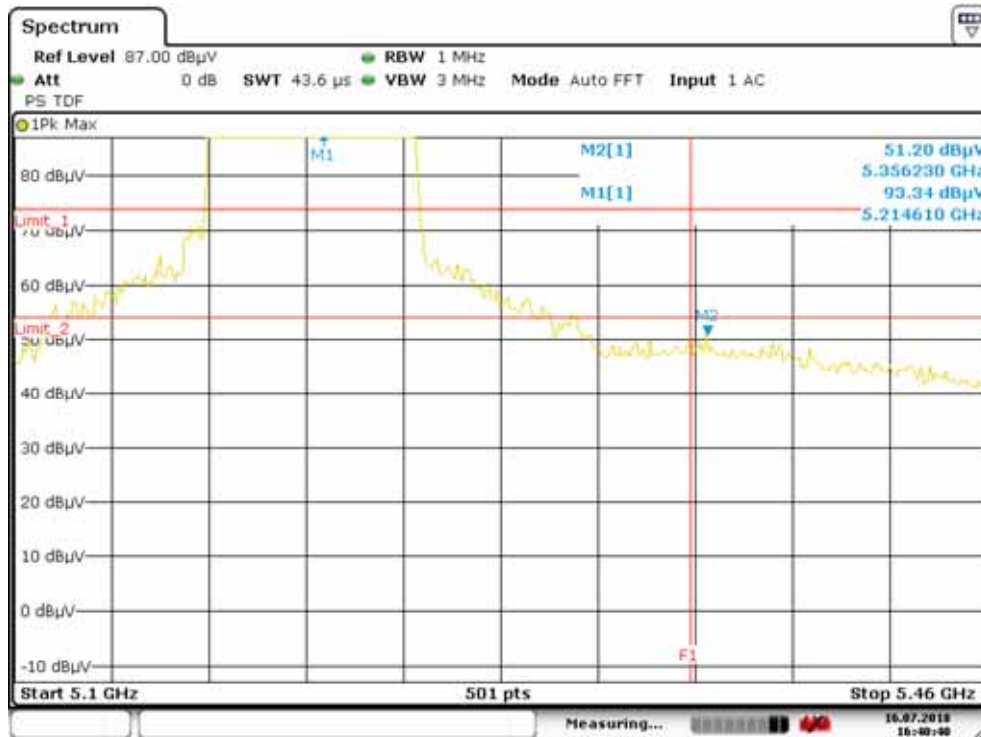

Date: 16.JUL.2018 16:40:40

Chain0+1 : Restricted Band Bandedge @ 802.11ac(VHT80) Mode Ch42 Upper AV

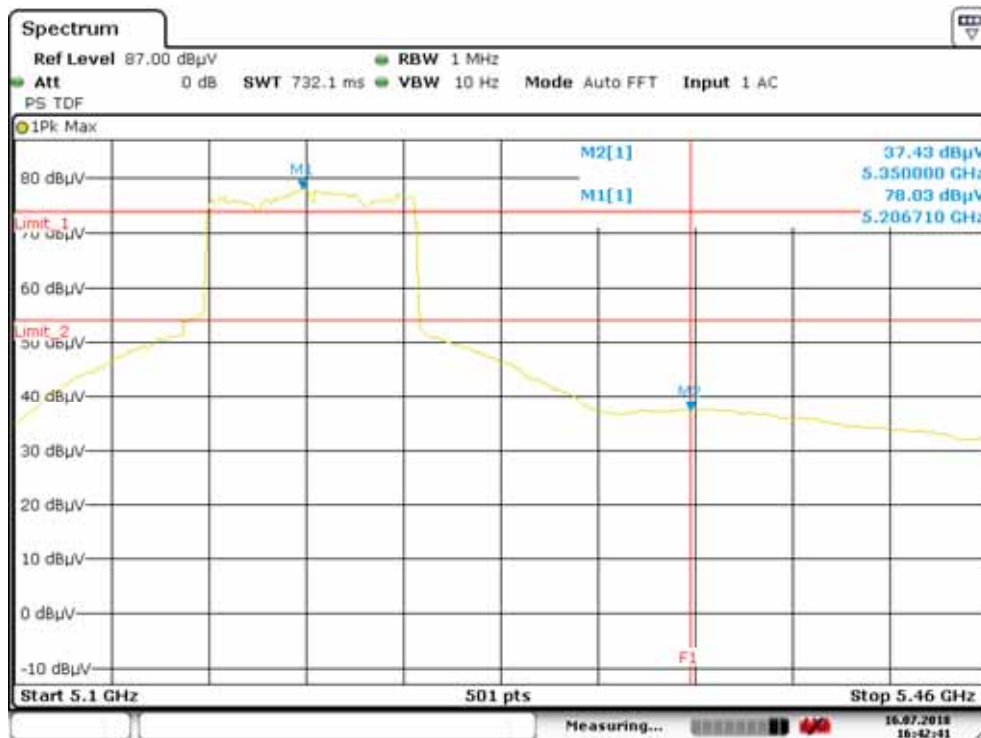

Date: 16.JUL.2018 16:42:41

Chain0 : Out-of-band emission limits for U-NII-3 @ mode 802.11a Ch149

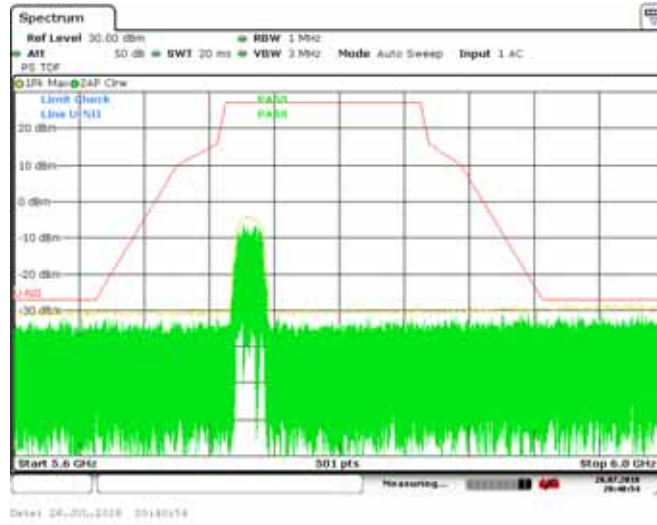

Chain0 : Out-of-band emission limits for U-NII-3 @ mode 802.11a Ch157

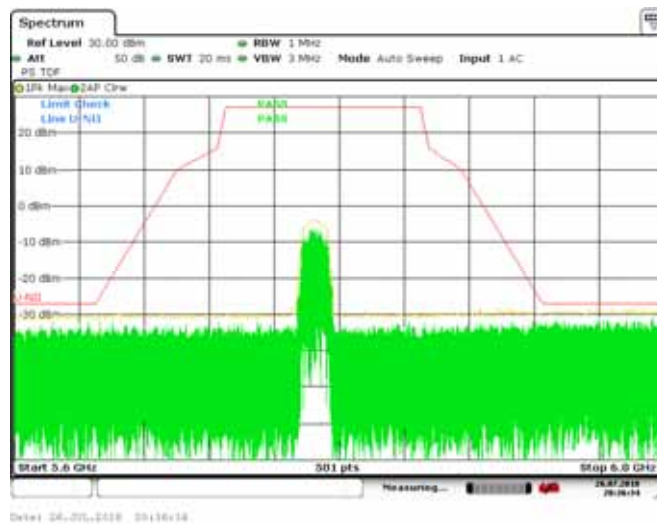

Chain0 : Out-of-band emission limits for U-NII-3 @ mode 802.11a Ch165

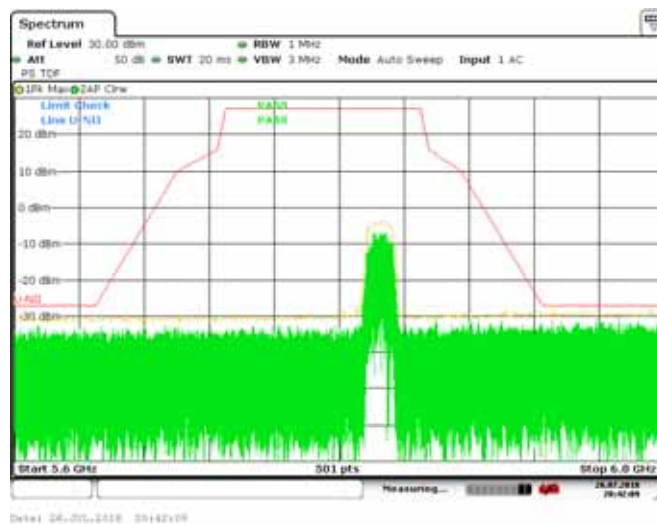

Chain1 : Out-of-band emission limits for U-NII-3 @ mode 802.11a Ch149

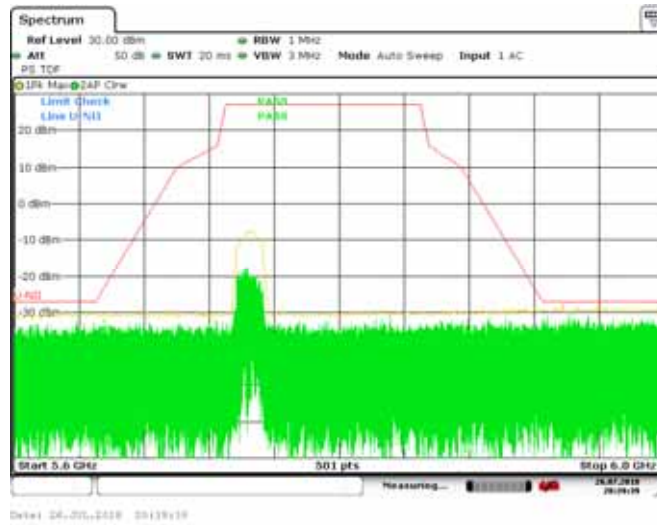

Chain1 : Out-of-band emission limits for U-NII-3 @ mode 802.11a Ch157

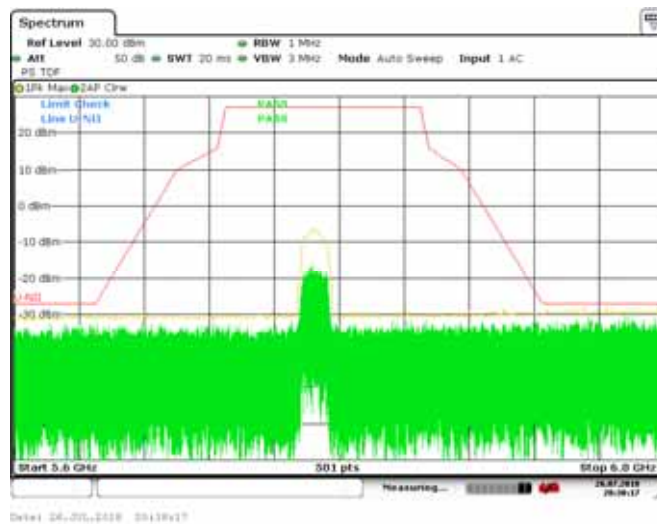

Chain1 : Out-of-band emission limits for U-NII-3 @ mode 802.11a Ch165

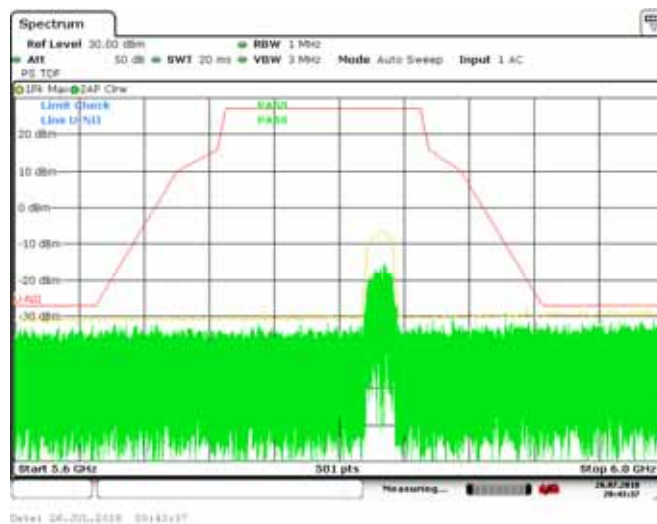

Chain0+1 : Out-of-band emission limits for U-NII-3 @ mode 802.11ac(VHT20) Ch149

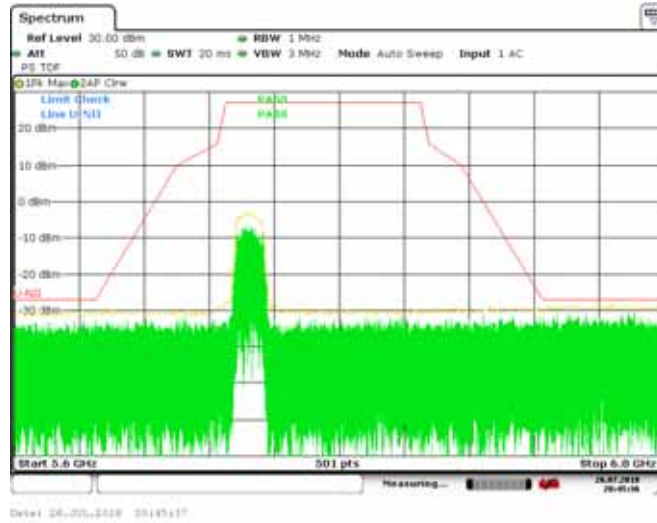

Chain0+1 : Out-of-band emission limits for U-NII-3 @ mode 802.11ac(VHT20) Ch157

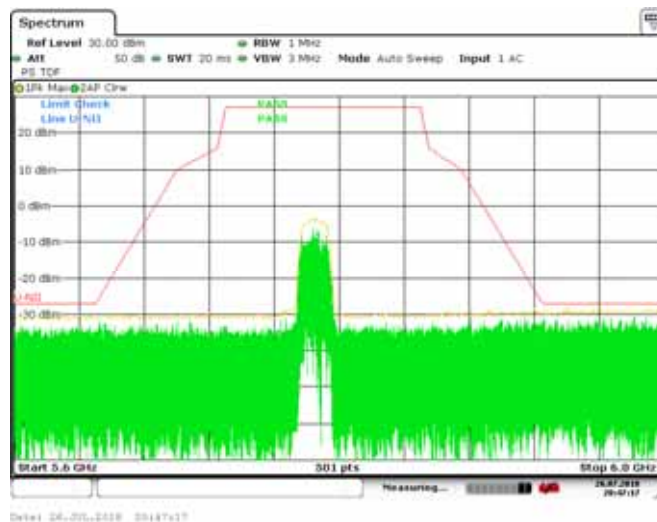

Chain0+1 : Out-of-band emission limits for U-NII-3 @ mode 802.11ac(VHT20) Ch165

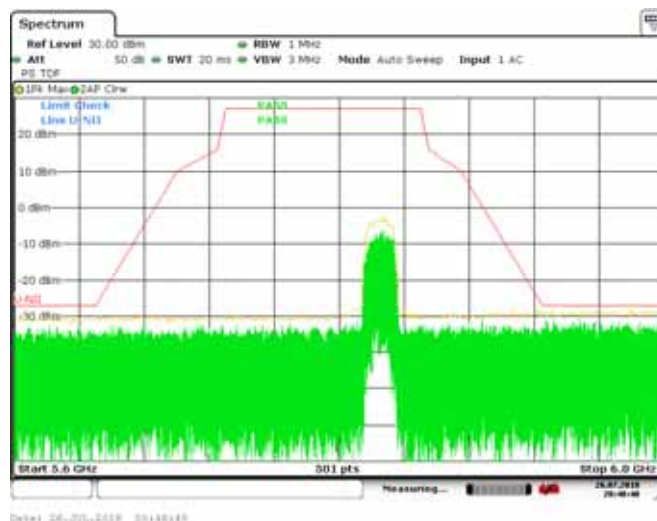

Chain0+1 : Out-of-band emission limits for U-NII-3 @ mode 802.11ac(VHT40) Ch151

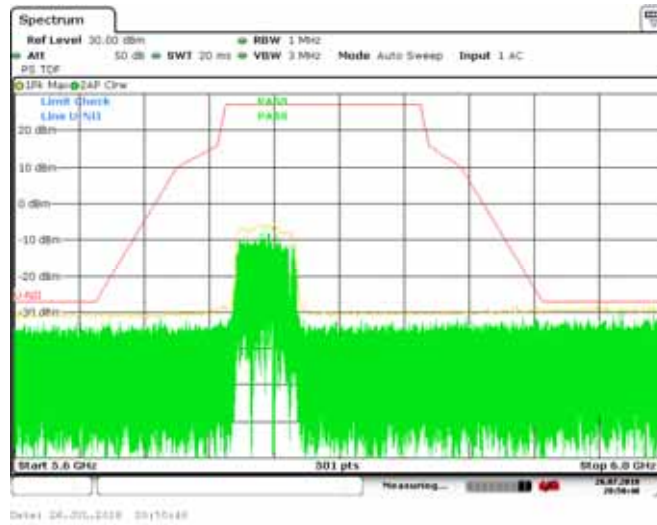

Chain0+1 : Out-of-band emission limits for U-NII-3 @ mode 802.11ac(VHT40) Ch159

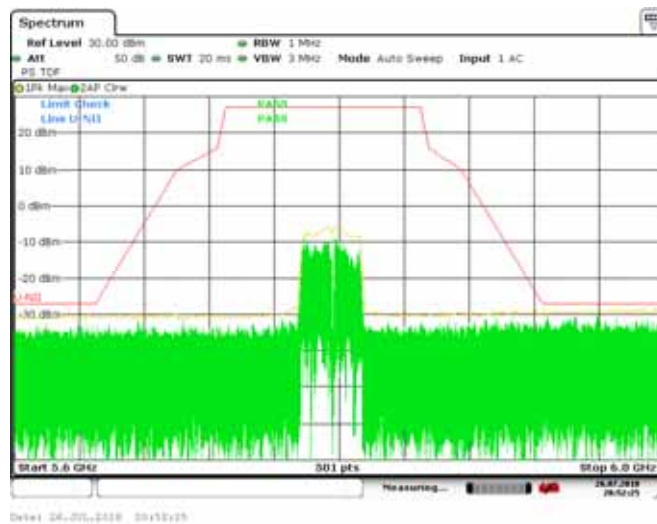

Chain0+1 : Out-of-band emission limits for U-NII-3 @ mode 802.11ac(VHT80) Ch155

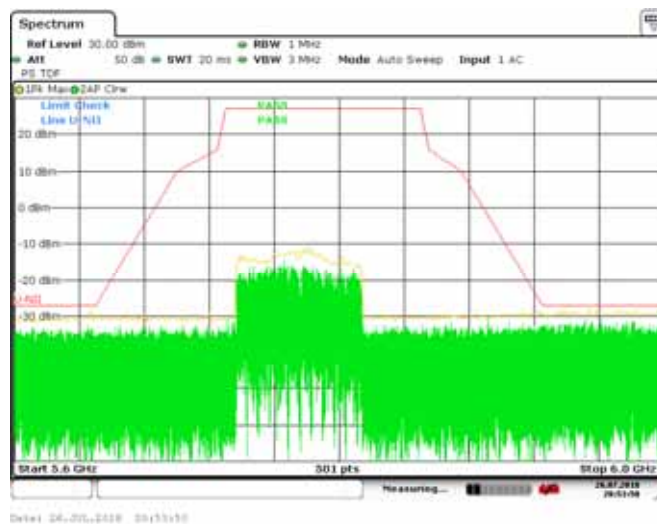

7. Dynamic Frequency Selection (DFS) test

7.1 Operating environment

Temperature:	25	
Relative Humidity:	50	%
Atmospheric Pressure:	1008	hPa

7.2 UNII Device Description

1. The UAP-AC-M operates in the following UNII bands:

- a. 5250-5350 MHz
- b. 5470-5725 MHz

2. Operating mode:

The EUT was defined as the client without radar detection function.

Associating peripheral:

The device was set up to associate with the master device (UAP-AC-M).

3. The maximum EIRP of this device is 11.39 dBm from UNII band. This device doesn't exceed 27dBm EIRP, so no transmit power control is implemented.

4. Below are the available 50 ohm antenna assemblies and their corresponding gains. 0dBi gain was used to set the -63dBm threshold level (-62dBm+1dB) during calibration of the conducted test setup.

5. Information regarding the parameters of the detected Radar Waveforms is not available to the end user.

7.2.1 Operating mode

Performance was measured at an active frequency of 5260 and 5500MHz, and the radar signal was centered at 5260 and 5500 MHz.

One laptop PC is connected to the AP via a wire Ethernet connection. A separate laptop PC is used as a host computer for the Station. The AP and the Station transmit output levels are set to normal operating condition.

System architectures were used under IP based mode.

7.3 Test Protocol and Requirements

For a Master Device, the DFS conformance requirements will be verified utilizing one short pulse radar type. Additionally, the Channel Move Time and Channel Closing Transmission Time requirements will be verified utilizing the long pulse radar type. The statistical performance check will be verified utilizing all radar type.

For a Client Device without DFS, the channel move time and channel closing transmission time requirements will be verified with one short pulse radar type.

For testing a Client Device with In-Service Monitoring, two configurations must be tested.

The Client Device detects the radar waveform:

The channel move time and channel closing transmission time requirements will be verified utilizing short pulse radar type and the long pulse radar type. The statistical performance check will be verified utilizing all radar types.

The Master Device detects the radar waveform:

The channel move time and channel closing transmission time requirements will be verified utilizing short pulse radar type.

A UNII network will employ a DFS function to:

- detect signals from radar systems and to avoid co-channel operation with these systems
- provide on aggregate a Uniform Spreading of the Operating Channels across the entire band. This applies to the 5250-5350 MHz and/ or 5470-5725 MHz bands.

Within the context of the operation of the DFS function, a UNII device will operate in either Master Mode or Client Mode. UNII devices operating in Client Mode can only operate in a network controlled by a UNII device operating in Master Mode.

The tables as below summarize the information contained.

Applicability of DFS Requirements Prior to Use of a Channel

Requirement	Operational Mode		
	Master	Client Without Radar Detection	Client With Radar Detection
Non-Occupancy Period	Yes	Not required	Yes
DFS Detection Threshold	Yes	Not required	Yes
Channel Availability Check Time	Yes	Not required	Not required
Uniform Spreading	Yes	Not required	Not required
UNII Detection Bandwidth	Yes	Not required	Yes

Applicability of DFS requirements during normal operation

Requirement	Operational Mode		
	Master	Client Without Radar Detection	Client With Radar Detection
DFS Detection Threshold	Yes	Not required	Yes
Channel Closing Transmission Time	Yes	Yes	Yes
Channel Move Time	Yes	Yes	Yes
UNII Detection Bandwidth	Yes	Not required	Yes

7.4 DFS Detection Thresholds and Limitations of each Parameter

Maximum Transmit Power	Value (See Notes 1 and 2)
200 mW	-64 dBm
200 mW	-62 dBm
<p>Note 1: This is the level at the input of the receiver assuming a 0 dBi receive antenna.</p> <p>Note 2: Throughout these test procedures an additional 1 dB has been added to the amplitude of the test transmission waveforms to account for variations in measurement equipment. This will ensure that the test signal is at or above the detection threshold level to trigger a DFS response.</p>	

Parameter	Value
Non-occupancy Period	Minimum 30 minutes
Channel Availability Check Time	60 seconds
Channel Move Time	10 seconds (See Note 1)
Channel Closing Transmission Time	200 milliseconds + an aggregate of 60 milliseconds over remaining 10 second period (See Note 1 and 2)
UNII Detection Bandwidth	Minimum 80% of the UNII 99% transmission power bandwidth. (See Note 3)
<p>Note 1: The instant that the Channel Move Time and the Channel Closing Transmission Time begins is as follows:</p> <ul style="list-style-type: none"> • For the Short Pulse Radar Test Signals this instant is the end of the Burst. • For the Frequency Hopping radar Test Signal, this instant is the end of the last radar Burst generated. • For the Long Pulse Radar Test Signal this instant is the end of the 12 second period defining the Radar Waveform. <p>Note 2: The Channel Closing Transmission Time is comprised of 200 milliseconds starting at the beginning of the Channel Move Time plus any additional intermittent control signals required to facilitate a Channel move (an aggregate of 60 milliseconds) during the remainder of the 10 second period. The aggregate duration of control signals will not count quiet periods in between transmissions.</p> <p>Note 3: During the U-NII Detection Bandwidth detection test, radar type 1 is used and for each frequency step the minimum percentage of detection is 90 percent. Measurements are performed with no data traffic.</p>	

TEST REPORT

7.5 Radar Test Waveforms

This section provides the parameters for required test waveforms, minimum percentage of successful detections, and the minimum number of trials that must be used for determining DFS conformance. Step intervals of 0.1 microsecond for Pulse Width, 1 microsecond for PRI, 1 MHz for chirp width and 1 for the number of pulses will be utilized for the random determination of specific test waveforms.

Short Pulse Radar Test Waveforms

Radar Type	Pulse Width (µsec)	PRI (µsec)	Number of Pulses	Minimum Percentage of Successful Detection	Minimum Number of Trials
1	1	1428	18	60%	30
2	1-5	150-230	23-29	60%	30
3	6-10	200-500	16-18	60%	30
4	11-20	200-500	12-16	60%	30
Aggregate (Radar Types 1-4)				80%	120

A minimum of 30 unique waveforms are required for each of the Short Pulse Radar Type 2 through 4. For Short Pulse Radar Type 1, the same waveform is used a minimum of 30 times. If more than 30 waveforms are used for Short Pulse Radar Type 2 through 4, then each additional waveform must also be unique and not repeated from the previous waveforms.

The aggregate is the average of the percentage of successful detections of Short Pulse Radar Type 1-4.

Long Pulse Radar Test Waveforms

Radar Type	Pulse Width (µsec)	Chirp Width (MHz)	PRI (µsec)	Number of Pulses per Burst	Number of Bursts	Minimum Percentage of Successful Detection	Minimum Number of Trials
5	50-100	5-20	1000-2000	1-3	8-20	80%	30

The parameters for this waveform are randomly chosen. Thirty unique waveforms are required for the Long Pulse radar test signal. If more than 30 waveforms are used for the Long Pulse radar test signal, then each additional waveform must also be unique and not repeated from the previous waveforms.

Each waveform is defined as follows:

- 1) The transmission period for the Long Pulse Radar test signal is 12 seconds.
- 2) There are a total of 8 to 20 Bursts in the 12 second period, with the number of Bursts being randomly chosen. This number is Burst_Count.
- 3) Each Burst consists of 1 to 3 pulses, with the number of pulses being randomly chosen. Each Burst within the 12 second sequence may have a different number of pulses.
- 4) The pulse width is between 50 and 100 microseconds, with the pulse width being randomly chosen. Each pulse within a Burst will have the same pulse width. Pulses in different Bursts may have different pulse widths.
- 5) Each pulse has a linear FM chirp between 5 and 20 MHz, with the chirp width being randomly chosen. Each pulse within a Burst will have the same chirp width. Pulses in different Bursts may have different chirp widths. The chirp is centered on the pulse. For example, with a radar frequency of 5300 MHz and a 20 MHz chirped signal, the chirp starts at 5290 MHz and ends at 5310 MHz.
- 6) If more than one pulse is present in a Burst, the time between the pulses will be between 1000 and 2000 microseconds, with the time being randomly chosen. If three pulses are present in a Burst, the time between the first and second pulses is chosen independently of the time between the second and third pulses.
- 7) The 12 second transmission period is divided into even intervals. The number of intervals is equal to Burst_Count. Each interval is of length $(12,000,000 / \text{Burst_Count})$ microseconds. Each interval contains one Burst. The start time for the Burst, relative to the beginning of the interval, is between 1 and $[(12,000,000 / \text{Burst_Count}) - (\text{Total Burst Length}) + (\text{One Random PRI Interval})]$ microseconds, with the start time being randomly chosen. The step interval for the start time is 1 microsecond. The start time for each Burst is chosen independently.

A representative example of a Long Pulse radar test waveform:

- 1) The total test signal length is 12 seconds.
- 2) 8 Bursts are randomly generated for the Burst_Count.
- 3) Burst 1 has 2 randomly generated pulses.
- 4) The pulse width (for both pulses) is randomly selected to be 75 microseconds.

TEST REPORT

- 5) The PRI is randomly selected to be at 1213 microseconds.
- 6) Bursts 2 through 8 are generated using steps 3 – 5.
- 7) Each Burst is contained in even intervals of 1,500,000 microseconds. The starting location for Pulse 1, Burst 1 is randomly generated (1 to 1,500,000 minus the total Burst 1 length + 1 random PRI interval) at the 325,001 microsecond step. Bursts 2 through 8 randomly fall in successive 1,500,000 microsecond intervals (i.e. Burst 2 falls in the 1,500,001 – 3,000,000 microsecond range).

Graphical Representation of a Long Pulse radar Test Waveform

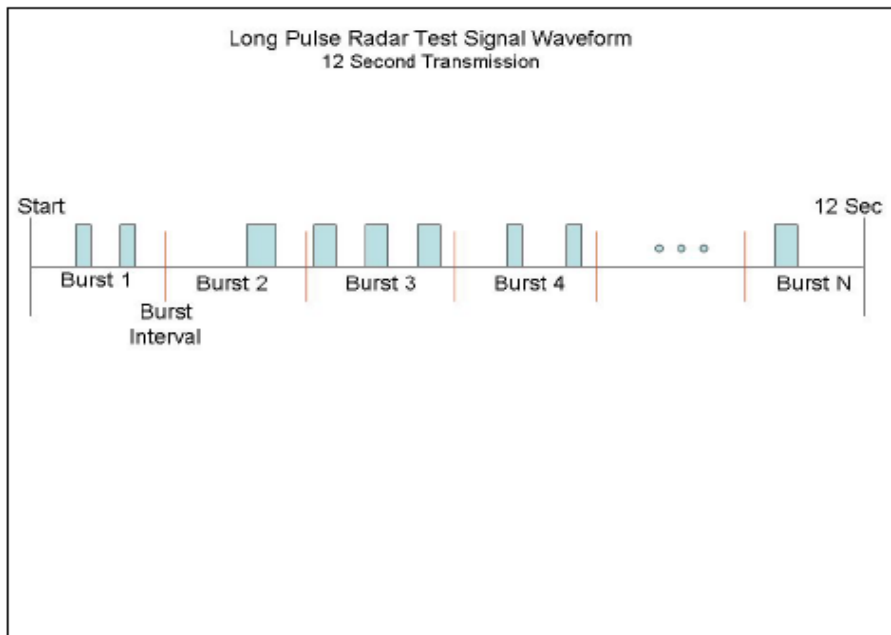

Frequency Hopping Radar Test Waveforms

Radar Type	Pulse Width (μsec)	PRI (μsec)	Pulses per Hop	Hopping Rate (kHz)	Hopping Sequence Length (msec)	Minimum Percentage of Successful Detection	Minimum Number of Trials
6	1	333	9	0.333	300	70%	30

For the Frequency Hopping Radar Type, the same *Burst* parameters are used for each waveform.

The hopping sequence is different for each waveform and a 100-length segment is selected from the hopping sequence defined by the following algorithm:

The first frequency in a hopping sequence is selected randomly from the group of 475 integer frequencies from 5250 – 5724 MHz. Next, the frequency that was just chosen is removed from the group and a frequency is randomly selected from the remaining 474 frequencies in the group. This process continues until all 475 frequencies are chosen for the set. For selection of a random frequency, the frequencies remaining within the group are always treated as equally likely.

7.6 Radar Waveform Calibration

The following equipment setup was used to calibrate the conducted radar waveform. A spectrum analyzer is used to establish the test signal level for each radar type. During this process, there were no transmissions by either Master or Client device. The spectrum analyzer was switched to the zero span (time domain) mode at the frequency of the radar waveform generator. The peak detection was utilized. The spectrum analyzer RBW and VBW were set to at least 3MHz.

The signal generator amplitude and/ or step attenuators were set so that the power level measured at the spectrum analyzer was equal to the DFS detection threshold that is required for the tests.

The signal generator amplitude was set so that the power level measured at the spectrum analyzer was –61 dBm.

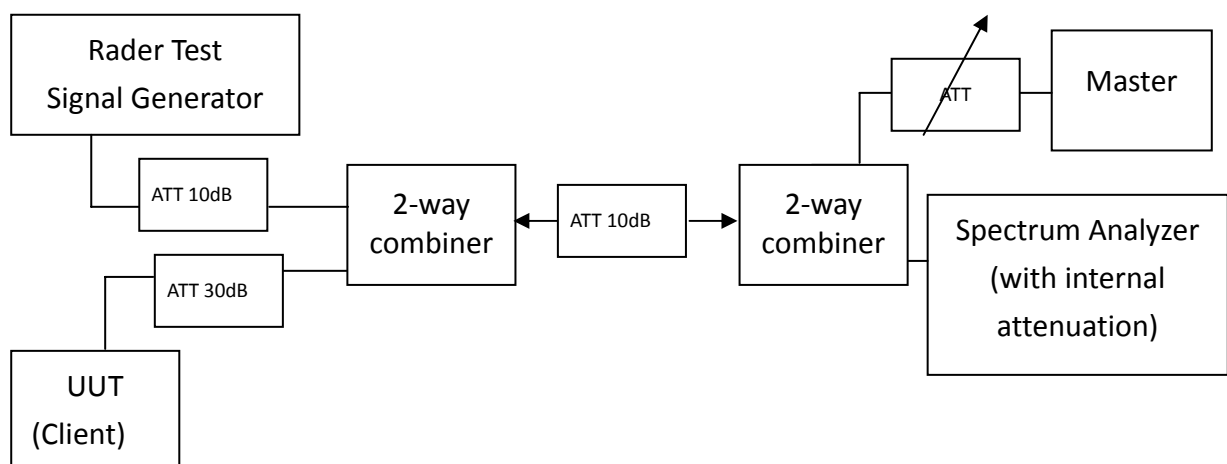

7.6.1 Radar Waveform Calibration Plots

Type Radar Signal @ 802.11a mode at 5260 MHz

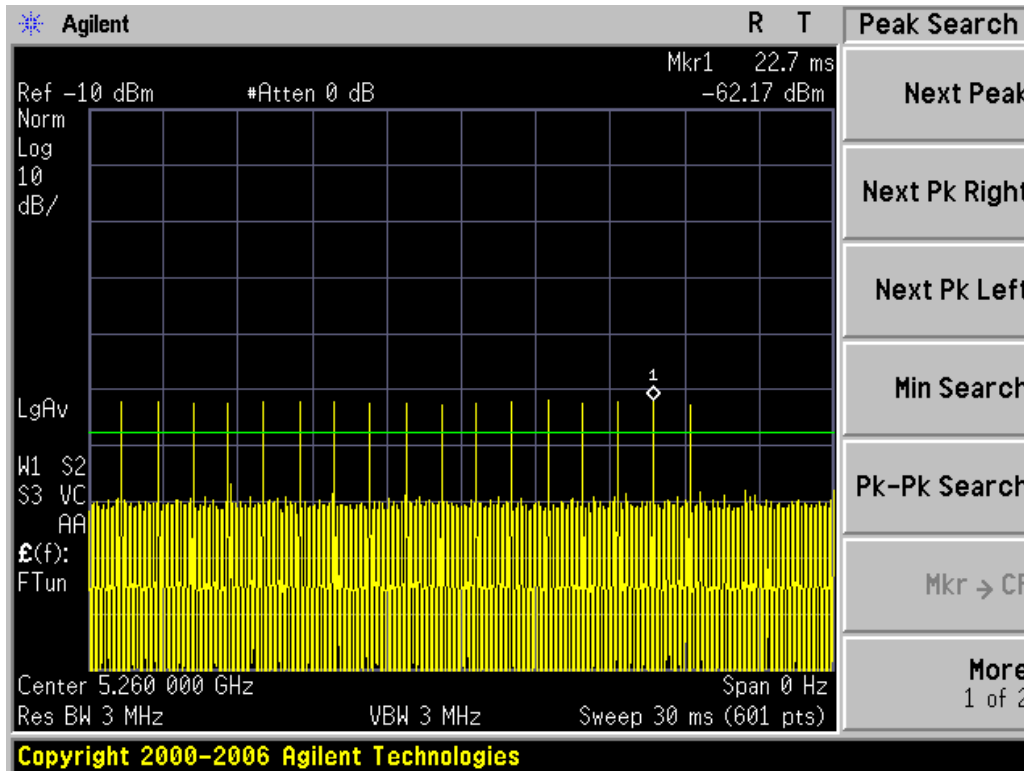

Type Radar Signal @ 802.11a mode at 5500 MHz

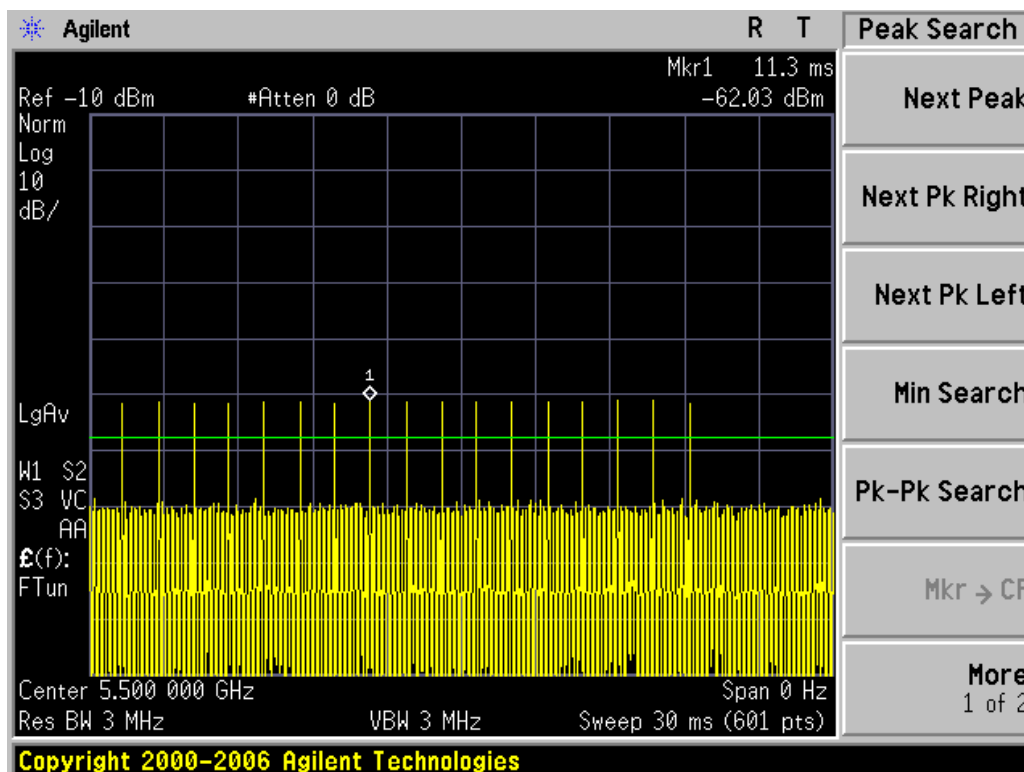

7.7 Test instruments and setup

7.7.1 Deviation about the radar waveform

No deviation.

7.7.2 Test setup

Setup for Client with injection at the Master (Client Mode without DFS detection)

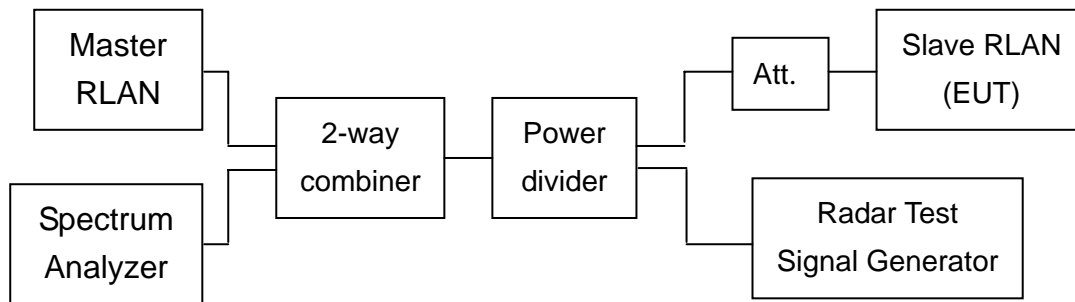

7.8 DFS test results

7.8.1 Test summary

This EUT was defined as the Client without DFS detection.

Clause	Parameter	Required	Result
15.407	DFS Detection Threshold	Not Required	N/A
15.407	Channel Availability Check Time	Not Required	N/A
15.407	Channel Move Time	Applicable	Pass
15.407	Channel Closing Transmission Time	Applicable	Pass
15.407	Non-Occupancy Period	Applicable	Pass
15.407	Uniform Spreading	Not Required	N/A
15.407	UNII Detection Bandwidth	Not Required	N/A

7.8.2 DFS test result

7.8.2.1 Channel Move time

Rader Type (5260MHz)

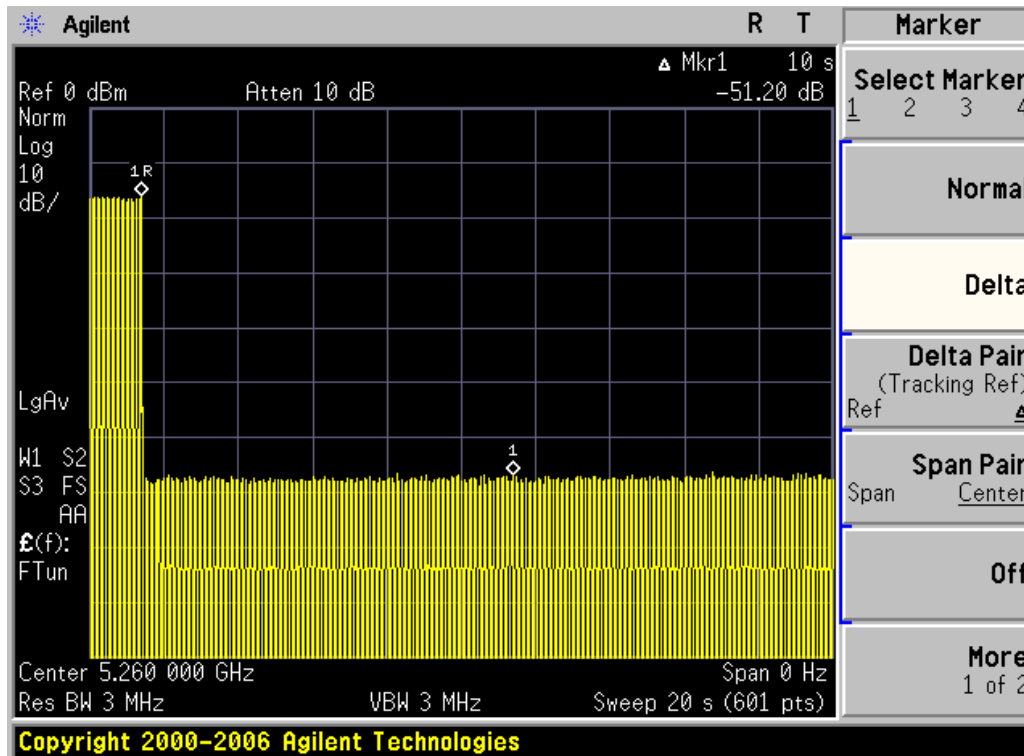

Rader Type (5500MHz)

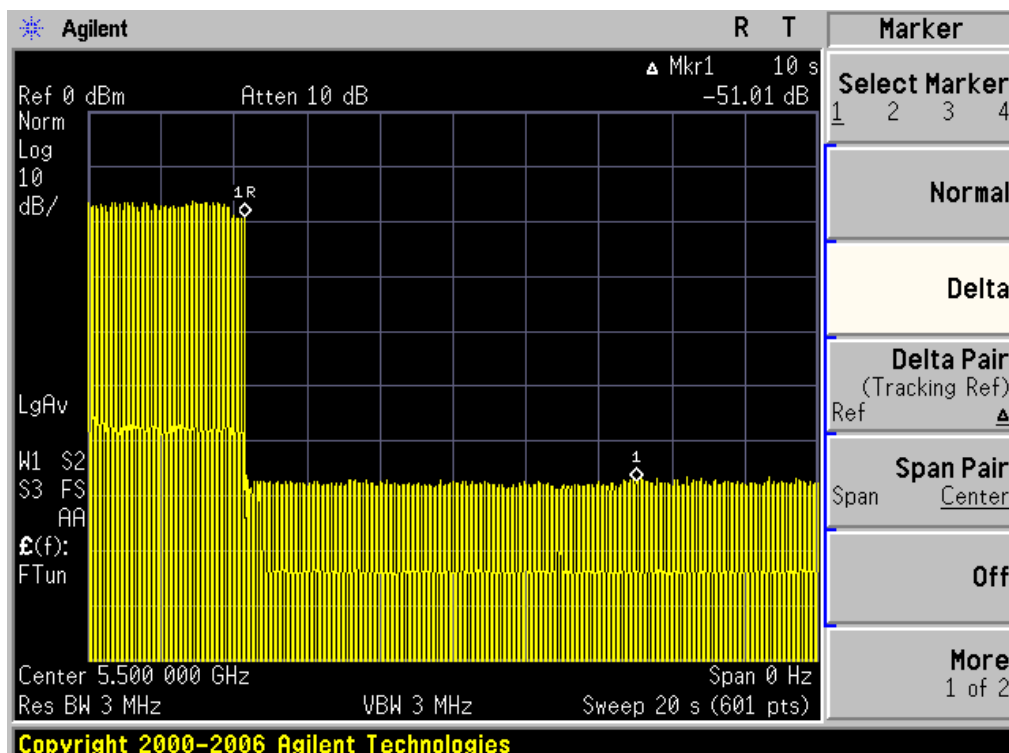

7.8.2.2 Channel Closing Transmission Time

Channel Closing Transmission Time 5260 MHz

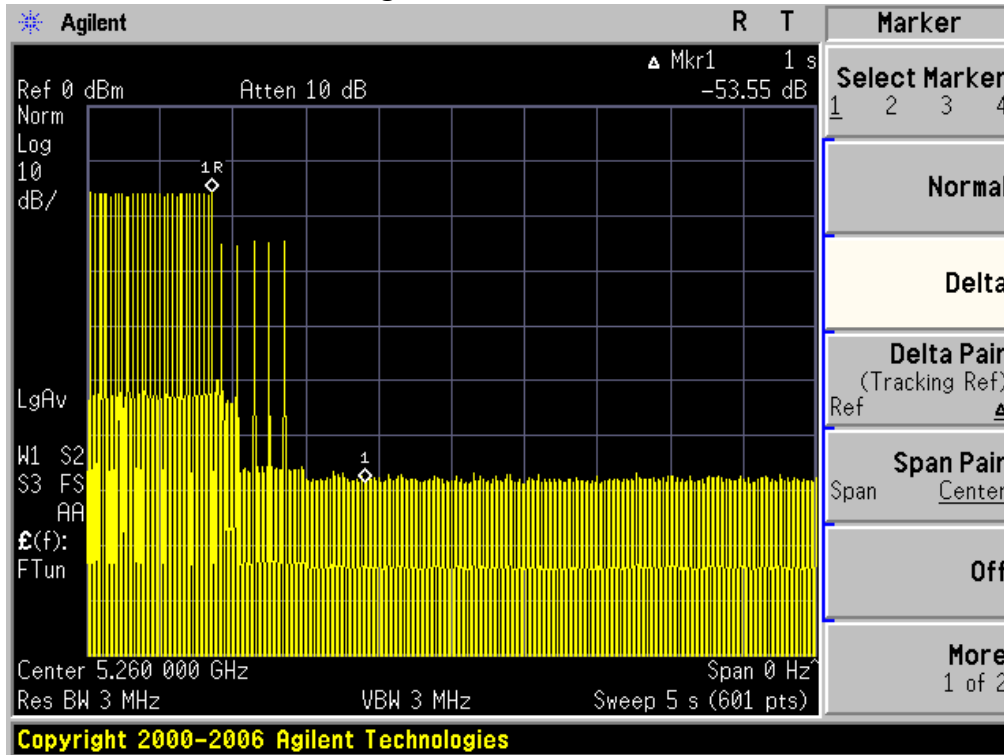

Single plus Channel Closing Transmission Time 5260 MHz

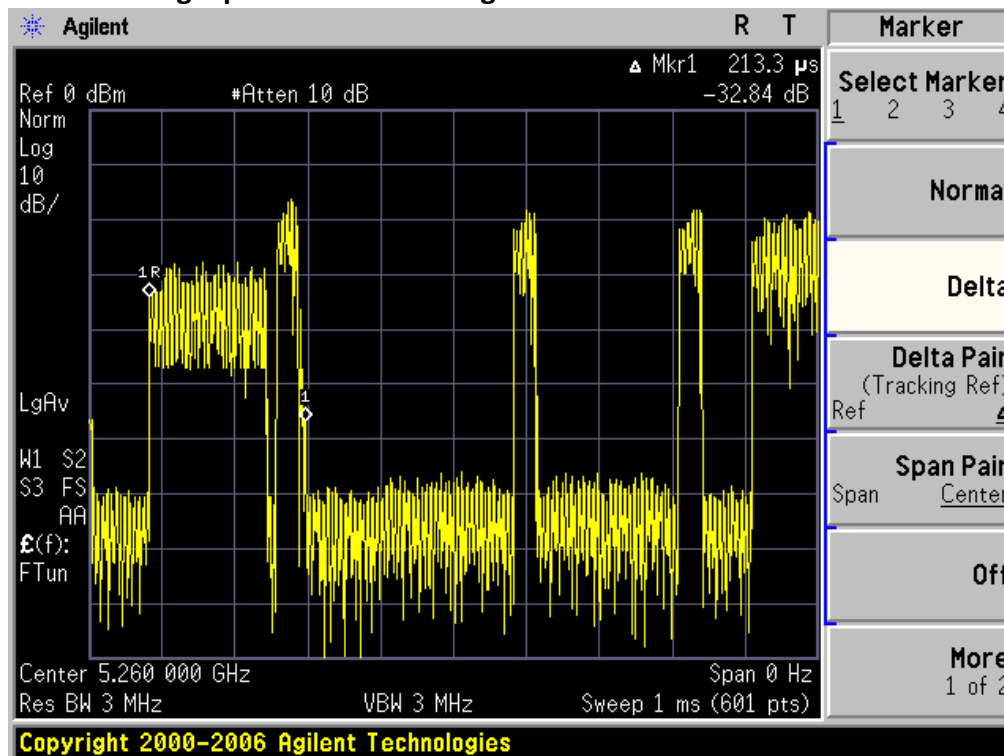

Channel Closing Transmission Time 5500 MHz

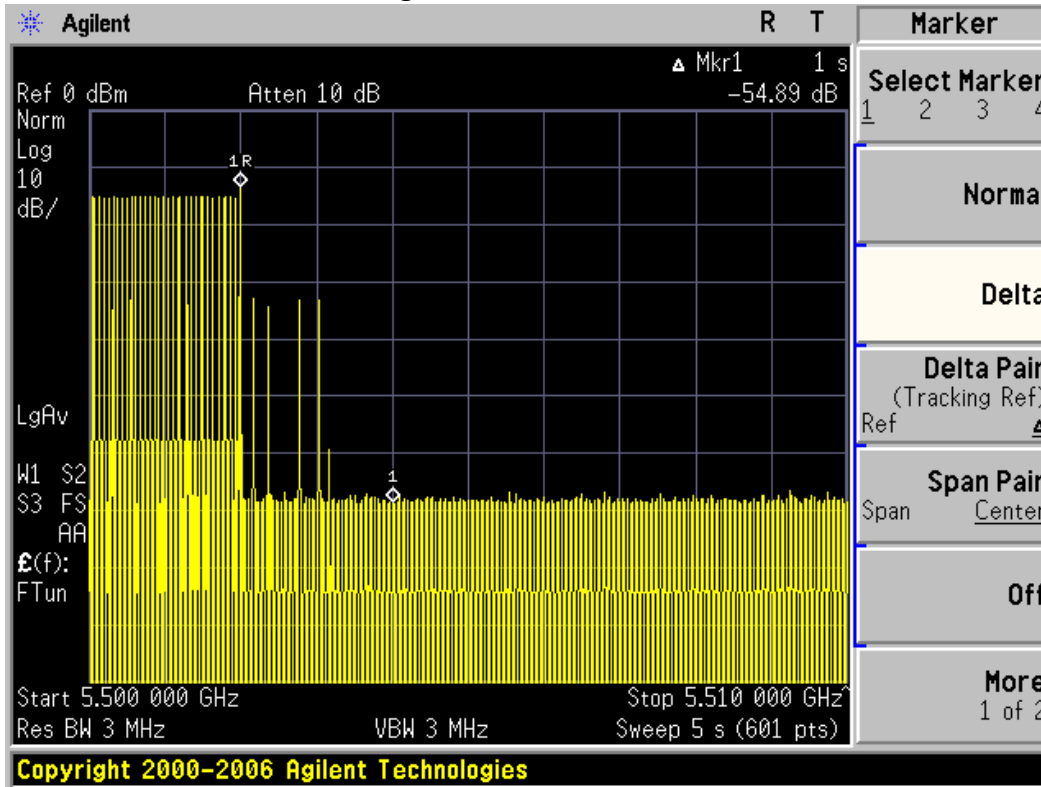

Single plus Channel Closing Transmission Time 5500 MHz

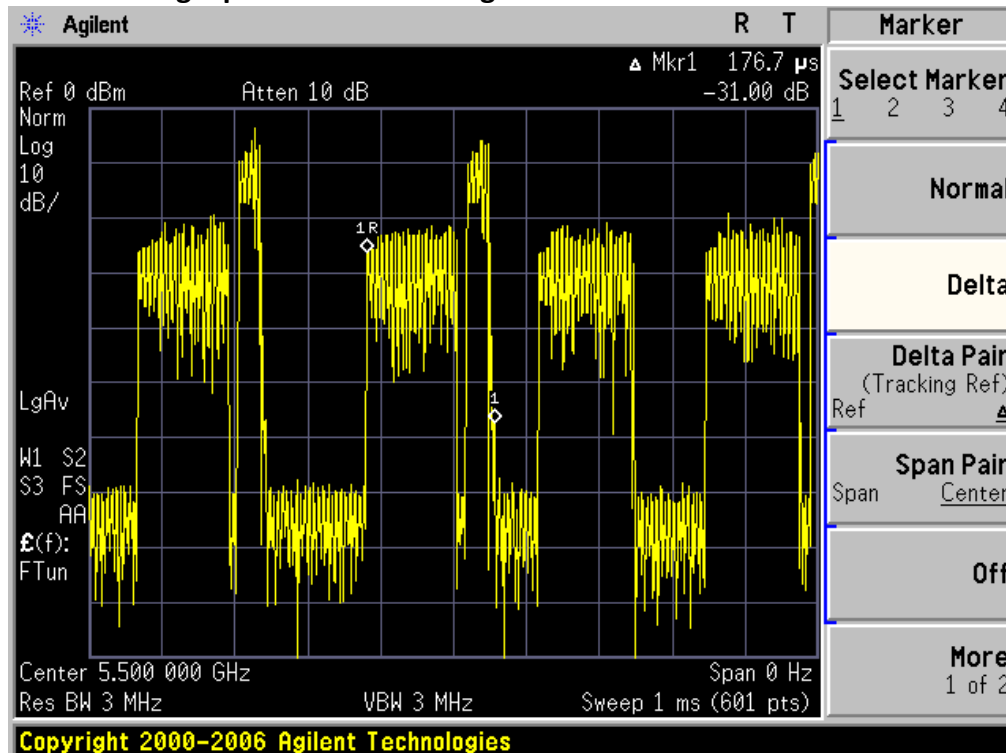

TEST REPORT

Mode	Channel	Frequency (Mhz)	Radar type	Single pulse (ms)	Pulse number	Total time (ms)
802.11n (HT20)	52	5260	1	0.213	5	1.065
802.11n (HT40)	102	5500	1	0.177	4	0.708

7.8.2.3 Non-Occupancy Period

No transmissions were observed on the previously active channel during 30 minutes observation time for the EUT.

Non occupancy period 5260 MHz

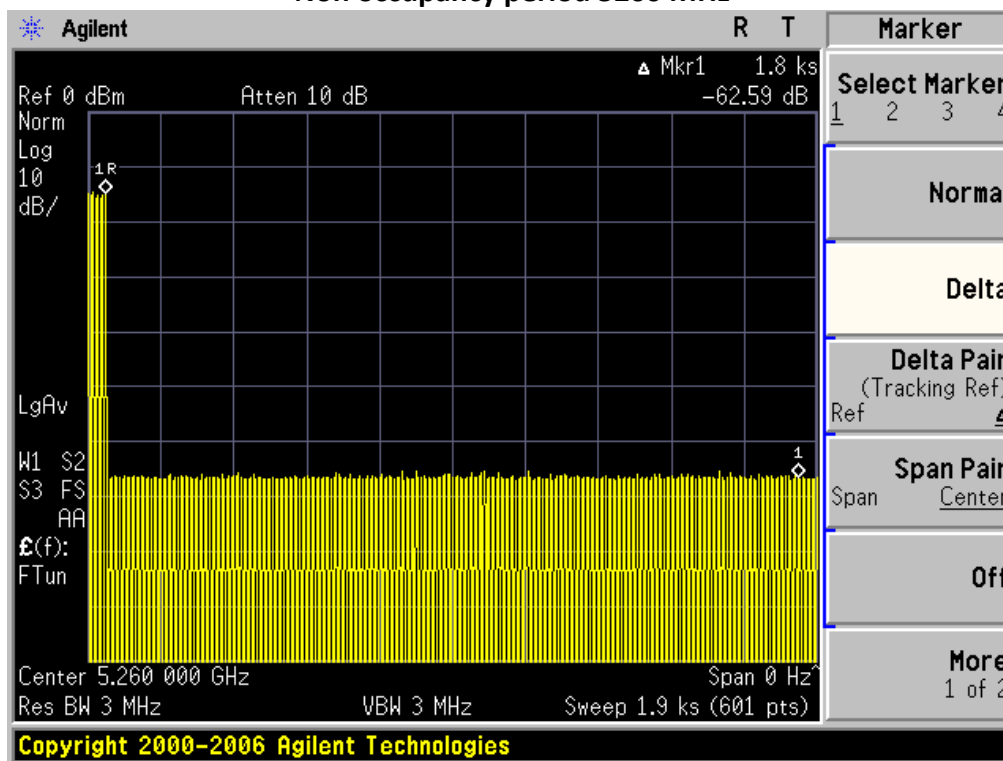

Non occupancy period 5500 MHz

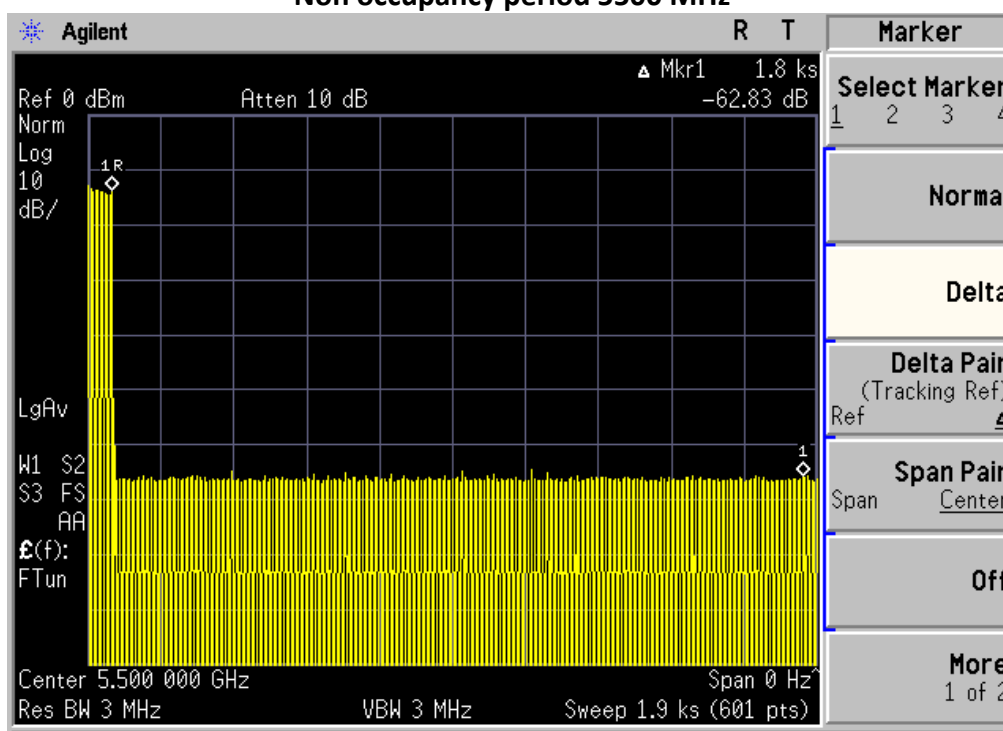

8.AC Power Line Conducted Emission

8.1 Measuring instrument setting

Receiver Function	Setting
Detector	QP
Start frequency	0.15MHz
Stop frequency	30MHz
IF bandwidth	9 kHz
Attenuation	10dB

8.2 Test Procedure

Step 1	Configure the EUT according to ANSI C63.10:2013. The EUT or host of EHT has to be placed 0.4 meter far from the conducting wall of the shielding room and at least 80 centimeters from any other grounded conducting surface.
Step 2	Connect EUT or host of EUT to the power mains through a line impedance stabilization network.
Step 3	All the companion devices are connected to the other LISN. The LISN should provide 50Uh/50ohms coupling impedance.
Step 4	The frequency range from 150 kHz to 30MHz was searched.
Step 5	Set the test-receiver system to peak detector and specified bandwidth with maximum hold mode.
Step 6	The measurement has to be done between each power line and ground at the power terminal.

8.3 Test Diagram

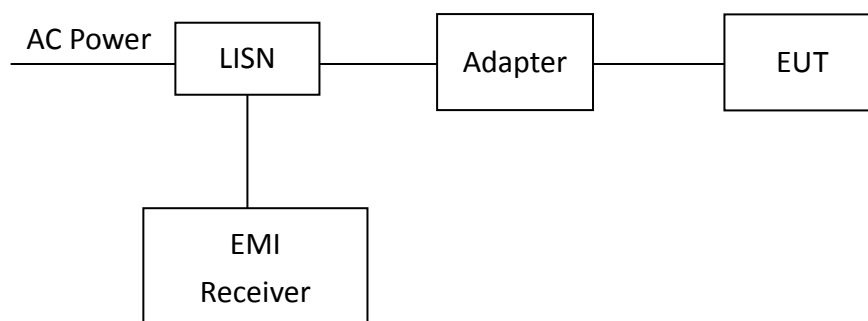

8.4 Limit

Frequency (MHz)	Conducted Limit (dBuV)	
	Q.P.	Ave.
0.15~0.50	66 – 56	56 – 46
0.50~5.00	56	46
5.00~30.0	60	50

8.5 Operating Environment Condition

Temperature () :	25
Relative Humidity (%) :	50
Atmospheric Pressure (hPa) :	1010

8.6 Test Results

Phase: Live Line
 Model No.: PLTN-RB1VO
 Test Condition: Tx mode

Frequency (MHz)	Corr. Factor (dB)	Reading QP (dBuV)	Level QP (dBuV)	Limit QP (dBuV)	Reading AV (dBuV)	Level AV (dBuV)	Limit AV (dBuV)	Margin (dB)	
								QP	AV
0.156	0.08	47.94	48.02	65.69	33.97	34.05	55.69	-17.67	-21.64
0.273	0.09	33.37	33.46	61.03	19.87	19.96	51.03	-27.57	-31.07
0.440	0.10	38.40	38.50	57.07	31.93	32.03	47.07	-18.57	-15.03
2.946	0.27	28.15	28.43	56.00	17.54	17.82	46.00	-27.57	-28.18
14.440	0.92	40.97	41.90	60.00	31.33	32.25	50.00	-18.10	-17.75
23.140	1.26	26.39	27.65	60.00	19.93	21.18	50.00	-32.35	-28.82

Remark:

1. Corr. Factor (dB) = LISN Factor (dB) + Cable Loss (dB)
2. Level (dBuV) = Corr. Factor (dB) + Reading (dBuV)
3. Margin (dB) = Level (dBuV) – Limit (dBuV)

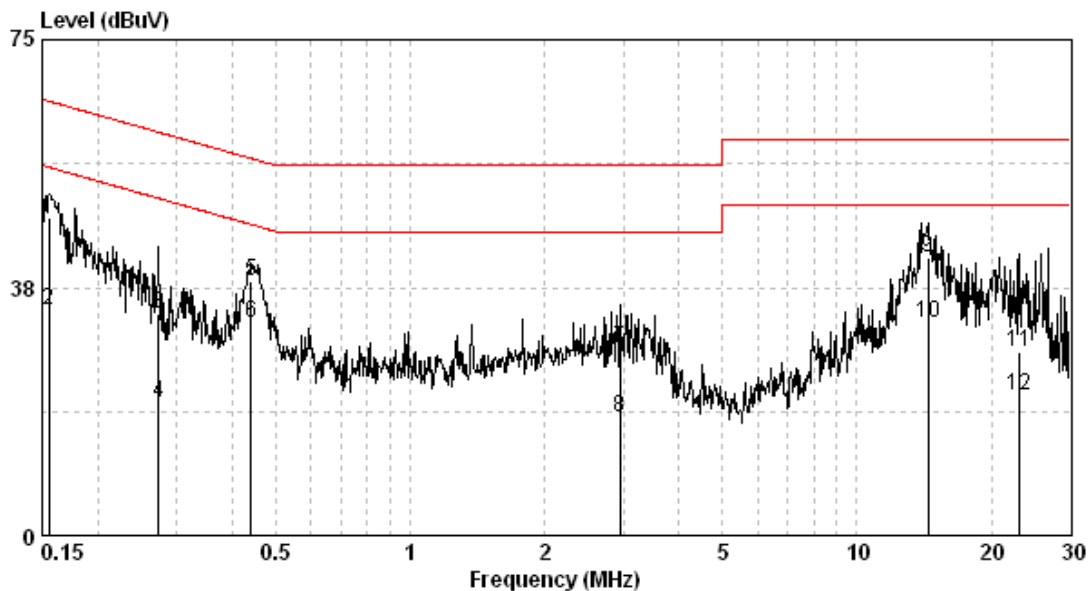

TEST REPORT

Phase: Neutral Line
 Model No.: PLTN-RB1VO
 Test Condition: Tx mode

Frequency (MHz)	Corr. Factor (dB)	Reading QP (dBuV)	Level QP (dBuV)	Limit QP (dBuV)	Reading AV (dBuV)	Level AV (dBuV)	Limit AV (dBuV)	Margin (dB)	
								QP	AV
0.158	0.08	47.50	47.58	65.56	34.20	34.28	55.56	-17.98	-21.28
0.249	0.09	34.29	34.37	61.78	21.64	21.73	51.78	-27.40	-30.05
0.444	0.10	38.55	38.65	56.98	32.42	32.52	46.98	-18.33	-14.46
0.989	0.15	28.61	28.76	56.00	21.68	21.83	46.00	-27.24	-24.17
3.472	0.28	28.45	28.73	56.00	19.91	20.19	46.00	-27.27	-25.81
14.594	0.75	42.10	42.85	60.00	32.89	33.63	50.00	-17.15	-16.37

Remark:

1. Corr. Factor (dB) = LISN Factor (dB) + Cable Loss (dB)
2. Level (dBuV) = Corr. Factor (dB) + Reading (dBuV)
3. Margin (dB) = Level (dBuV) – Limit (dBuV)

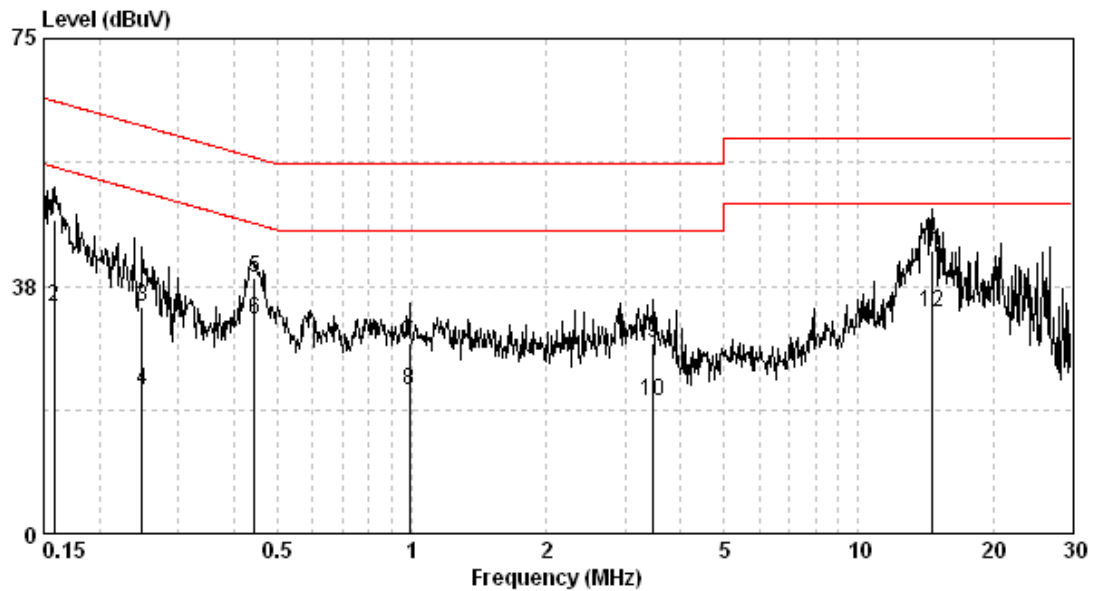

Appendix A: Test equipment list

Test Equipment/ Test site	Brand	Model No.	Serial No.	Calibration Date	Next Calibration Date
ESCI EMI Test Receiver	Rohde & Schwarz	ESCI	100018	2017/11/21	2018/11/20
Spectrum Analyzer	Rohde & Schwarz	FSP30	100245	2018/02/23	2019/02/22
Horn Antenna (1-18G)	SHWARZBECK	BBHA 9120 D	9120D-456	2018/01/23	2019/01/22
Horn Antenna (14-42G)	SHWARZBECK	BBHA 9170	BBHA9170159	2017/09/04	2020/09/02
Broadband Antenna	SHWARZBECK	VULB 9168	9168-172	2018/04/23	2019/04/22
Pre-Amplifier	EMC Co.	EMC12635SE	980205	2017/11/28	2018/11/27
Pre-Amplifier	MITEQ	JS4-26004000--27 -8A	828825	2017/08/23	2018/08/22
Power Meter	Anritsu	ML2495A	0844001	2017/10/18	2018/10/17
Power Sensor	Anritsu	MA2411B	0738452	2017/10/18	2018/10/17
Signal Analyzer	Agilent	N9030A	MY51380492	2017/08/29	2018/08/28
966-2(A) Cable 9kHz~26.5GHz	SUHNER	SMA / EX 100	N/A	2017/08/15	2018/08/14
966-2(B) Cable 9kHz~26.5GHz	SUHNER	SUCOFLEX 104P	CB0005	2017/08/15	2018/08/14
RF Cable 9kHz~26.5GHz	SUHNER	SUCOFLEX 102	CB0006	2018/05/03	2019/05/02

Note: No Calibration Required (NCR).

Test Equipment/ Test site	Brand	Model No.	Serial No.	Calibration Date	Next Calibration Date
966-2_3m Semi-Anechoic Chamber	966_2	CEM-966_2	N/A	2018/03/05	2019/03/04
966-2_3m Semi-Anechoic Chamber	966_2	CEM-966_2	N/A	2018/03/28	2019/03/27
High Pass Filter	Wainwright	WHKX3.0/ 18G-12SS	N/A	2018/06/01	2019/05/31
Active Loop Antenna	SCHWARZBECK MESS-ELEKTRONIC	FMZB1519	1519-067	2018/04/17	2019/04/16
Active Loop Antenna	SCHWARZBECK MESS-ELEKTRONIC	FMZB1519	1519-067	2018/04/17	2019/04/16
EMI Test Receiver	R&S	ESR7	101822	2018/06/12	2019/06/11
Two-Line V-Network	R&S	ENV216	101160	2018/07/24	2019/07/23
Two-Line -V-Network	R&S	ESH3-Z5	838979/014	2017/09/13	2018/09/12
CON-2 Shielded Room	N/A	N/A	N/A	NCR	NCR
CON-2 Cable	SUHNER	EMCCFD300-BM- NM-6000	170502	2018/05/07	2019/05/06
Test software	Audix	e3	4.20040112L	NCR	NCR

Note: No Calibration Required (NCR).

Appendix B: Measurement Uncertainty

This uncertainty represents an expanded uncertainty expressed at approximately the 95 % confidence level using a coverage factor of $k=2$.

Item	Uncertainty
Vertically polarized radiated disturbances from 30MHz~1GHz in a semi-anechoic chamber at a distance of 3m	5.14 dB
Horizontally polarized radiated disturbances from 30MHz~1GHz in a semi-anechoic chamber at a distance of 3m	5.22 dB
Vertically polarized Radiated disturbances from 1GHz~18GHz in a semi-anechoic chamber at a distance of 3m	3.64 dB
Horizontally polarized Radiated disturbances from 1GHz~18GHz in a semi-anechoic chamber at a distance of 3m	3.64 dB
Vertically polarized Radiated disturbances from 18GHz~40GHz in a semi-anechoic chamber at a distance of 3m	2.68 dB
Horizontally polarized Radiated disturbances from 18GHz~40GHz in a semi-anechoic chamber at a distance of 3m	2.68 dB
Radiated disturbances from 9kHz~30MHz in a semi-anechoic chamber at a distance of 3m	3.54 dB
Emission on the Band Edge Test	3.64 dB
Minimum 6dB Bandwidth	0.85 dB
Maximum Conducted Output Power	0.42 dB
Power Spectral Density	0.85 dB
Emissions In Non-Restricted Frequency Bands	0.85 dB
AC Power Line Conducted Emission	2.48 dB