

FCC - TEST REPORT

Report Number : **60.790.20.086.01R02** Date of Issue : February 5, 2021

Model : **FREEDOM FOCUS**

Product Type : **Merchandise Theft Deterrent System**

Applicant : Mobile Technologies Inc.

Address : 1050 NE 67th Ave, Hillsboro, OR 97124, United States of America

Production Facility : E-BI International, Inc.

Address : Floor 13, Tower C, Chuangwei Building, 008 Gaoxin South First Road, High-Tech Park, Nanshan, Shenzhen, China 518057

Test Result : **Positive** **Negative**

Total pages including Appendices : 23

TÜV SÜD Certification and Testing (China) Co., Ltd. Shenzhen Branch is a subcontractor to TÜV SÜD Product Service GmbH according to the principles outlined in ISO 17025.

TÜV SÜD Certification and Testing (China) Co., Ltd. Shenzhen Branch reports apply only to the specific samples tested under stated test conditions. Construction of the actual test samples has been documented. It is the manufacturer's responsibility to assure that additional production units of this model are manufactured with identical electrical and mechanical components. The manufacturer/importer is responsible to the Competent Authorities in Europe for any modifications made to the production units which result in non-compliance to the relevant regulations. TÜV SÜD Certification and Testing (China) Co., Ltd. Shenzhen Branch shall have no liability for any deductions, inferences or generalizations drawn by the client or others from TÜV SÜD Certification and Testing (China) Co., Ltd. Shenzhen Branch issued reports.

This report is the confidential property of the client. As a mutual protection to our clients, the public and ourselves, extracts from the test report shall not be reproduced except in full without our written approval

1 Table of Contents

1 Table of Contents	2
2 Description of Equipment Under Test.....	3
3 Summary of Test Standards	4
4 Details about the Test Laboratory	5
4.1 Test Equipment Site List	6
4.2 Measurement System Uncertainty	7
5 Summary of Test Results	8
6 General Remarks	9
7 Test Setups	10
7.1 Radiated test setups 9kHz-30MHz.....	10
7.2 Radiated test setups 30MHz-1GHz.....	10
7.3 Radiated test setups Above 1GHz	10
7.4 AC Power Line Conducted Emission test setups	11
7.5 Conducted RF test setups.....	11
8 Emission Test Results	12
8.1 Spurious Radiated Emission	12
8.2 Conducted Emission at AC Power Line	15
8.3 6dB & 99% Bandwidth	17
9 Test setup procedure.....	18
10 Appendix A - General Product Information.....	22

2 Description of Equipment Under Test

Description of the Equipment Under Test

Product: Merchandise Theft Deterrent System

Model no.: FREEDOM FOCUS

FCC ID: 2AA2X-15000256

Rating: Adapter Model:W&T-AD36W059350F
Input: AC100-240V. 1.0A
Output: DC 5.9V, 3.5A

Main unit input: DC 5.9V, 3.5A
Main unit outout(USB type-C):DC5.2V, 3.0A

Internal rechargeable battery: DC3.7V, type LIR2302H x 2
DC3.7V, type802245 x 2

Frequency: 125kHz (Tx and Rx)

Modulation: AM

Auxiliary Equipment Used during Test:

DESCRIPTION	MANUFACTURE R	MODEL NO.	REMARK
User Card	MTI	/	Provided by applicant

Auxiliary Software Used during Test:

DESCRIPTION	SOFTWARE NAME	VERSION	REMARK
/	/	/	/

3 Summary of Test Standards

Test Standards
FCC Part 15 Subpart C 10-1-20 Edition Federal Communications Commission, PART 15 — Radio Frequency Devices, Subpart C — Unintentional Radiators

All the tests were performed using the procedures from ANSI C63.4(2014) and ANSI C63.10 (2013).



China

4 Details about the Test Laboratory

Site 1

Company name: TÜV SÜD Certification and Testing (China) Co., Ltd. Shenzhen Branch
 Building 12&13 Zhiheng Wisdomland Business Park,
 Nantou Checkpoint Road 2,
 Shenzhen 518052, P.R.China
 FCC Registration Number: 514049
 ISED test site number: 10320A

Emission Tests	
Test Item	Test Site
FCC Part 15 Subpart C	
FCC Title 47 Part 15.205, 15.209 Spurious Radiated Emission	Site 1
FCC Title 47 Part 15.207 Conduct Emission	Site 1
FCC Title 47 Part 15.215 20dB & 99%Bandwidth	Site 1

4.1 Test Equipment Site List

Radiated emission Test – Site 1

DESCRIPTION	MANUFACTURER	MODEL NO.	SERIAL NO.	CAL. DUE DATE
EMI Test Receiver	Rohde & Schwarz	ESR 26	101269	2021-6-29
Signal Analyzer	Rohde & Schwarz	FSV40	101031	2021-6-22
Loop Antenna	Rohde & Schwarz	HFH2-Z2	100398	2021-7-7
Trilog Super Broadband Test Antenna	Schwarzbeck	VULB 9163	707	2021-8-4
Horn Antenna	Rohde & Schwarz	HF907	102294	2021-7-5
Wideband Horn Antenna	Q-PAR	QWH-SL-18-40-K-SG	12827	2021-6-21
Pre-amplifier	Rohde & Schwarz	SCU 18	102230	2021-6-21
Pre-amplifier	Rohde & Schwarz	SCU 40A	100432	2021-7-30
Attenuator	Agilent	8491A	MY39264334	2021-6-21
3m Semi-anechoic chamber	TDK	9X6X6	----	2022-10-28
Test software	Rohde & Schwarz	EMC32	Version 9.15.00	N/A

Conducted Emission Test – Site 1

DESCRIPTION	MANUFACTURER	MODEL NO.	SERIAL NO.	CAL. DUE DATE
EMI Test Receiver	Rohde & Schwarz	ESR 3	101782	2021-6-29
LISN	Rohde & Schwarz	ENV4200	100249	2021-6-12
LISN	Rohde & Schwarz	ENV432	101318	2021-6-12
LISN	Rohde & Schwarz	ENV216	100326	2021-6-12
LISN	Rohde & Schwarz	ENV216	102472	2021-6-12
ISN	Rohde & Schwarz	ENY81	100177	2021-6-12
ISN	Rohde & Schwarz	ENY81-CA6	101664	2021-6-12
High Voltage Probe	Schwarzbeck	TK9420(VT9420)	9420-584	2021-6-23
RF Current Probe	Rohde & Schwarz	EZ-17	100816	2021-6-28
Attenuator	Shanghai Huaxiang	TS2-26-3	080928189	2021-6-21
Test software	Rohde & Schwarz	EMC32	Version9.15.00	N/A
Shielding Room	TDK	CSR #1	----	2020-11-07

20dB & 99% Bandwidth, Peak Output Power, Spurious Emissions at Antenna Terminals, 100kHz Bandwidth of band edges, Power Spectral Density – Site 1

DESCRIPTION	MANUFACTURER	MODEL NO.	SERIAL NO.	CAL. DUE DATE
Signal Analyzer	Rohde & Schwarz	FSV40	101030	2021-6-21
RF Switch Module	Rohde & Schwarz	OSP120/OSP-B157	101226/100851	2021-6-21

4.2 Measurement System Uncertainty

Measurement System Uncertainty Emissions

System Measurement Uncertainty	
Items	Extended Uncertainty
Uncertainty for Radiated Emission in 3m chamber 9kHz-30MHz	4.76dB
Uncertainty for Radiated Emission in 3m chamber 30MHz-1000MHz	Horizontal: 5.12dB; Vertical: 5.10dB;
Uncertainty for Radiated Emission in 3m chamber 1000MHz-25000MHz	Horizontal: 5.01dB; Vertical: 5.00dB;
Uncertainty for Conducted Emission at AC Power Line 150kHz-30MHz	3.21dB
Uncertainty for conducted power test	1.16dB
Uncertainty for frequency test	0.6×10^{-7}



China

5 Summary of Test Results

Emission Tests				
FCC Part 15 Subpart C				
Test Condition	Pages	Test Result		
		Pass	Fail	N/A
FCC Title 47 Part 15.205, 15.209 Spurious Radiated Emission	12-14	<input checked="" type="checkbox"/>	<input type="checkbox"/>	<input type="checkbox"/>
FCC Title 47 Part 15.207 Conduct Emission	15-16	<input checked="" type="checkbox"/>	<input type="checkbox"/>	<input type="checkbox"/>
FCC Title 47 Part 15.215 20dB & 99% Bandwidth	17	<input checked="" type="checkbox"/>	<input type="checkbox"/>	<input type="checkbox"/>

6 General Remarks

Remarks

This submittal(s) (test report) is intended for **FCC ID: 2AA2X-15000256**, complies with Section 15.205, 15.207, 15.209, 15.215 of the FCC Part 15, Subpart C rules for the DCD grant.

The TX and RX frequency range is 125kHz.

The 3.7V battery is a backup in case the product is removed from its AC/DC adapter. Normally the product is fixed and connected to the adapter, therefore, all RF test results on this report are based on this case with the adapter. However, we have checked the result at 3.7V, no obvious difference.

SUMMARY:

- All tests according to the regulations cited on page 8 were

■ - Performed

□ - **Not** Performed

- The Equipment Under Test

■ - **Fulfills** the general approval requirements.

□ - **Does not** fulfill the general approval requirements.

Sample Received Date: December 21, 2020

Testing Start Date: December 23, 2020

Testing End Date: January 20, 2021

- TÜV SÜD Certification and Testing (China) Co., Ltd. Shenzhen Branch -

Reviewed by:

Prepared by:

Tested by:



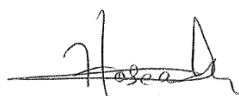



Eric LI
EMC Project Manager

Hosea CHAN
EMC Project Engineer

Louise Liu
EMC Test Engineer

7 Test Setups

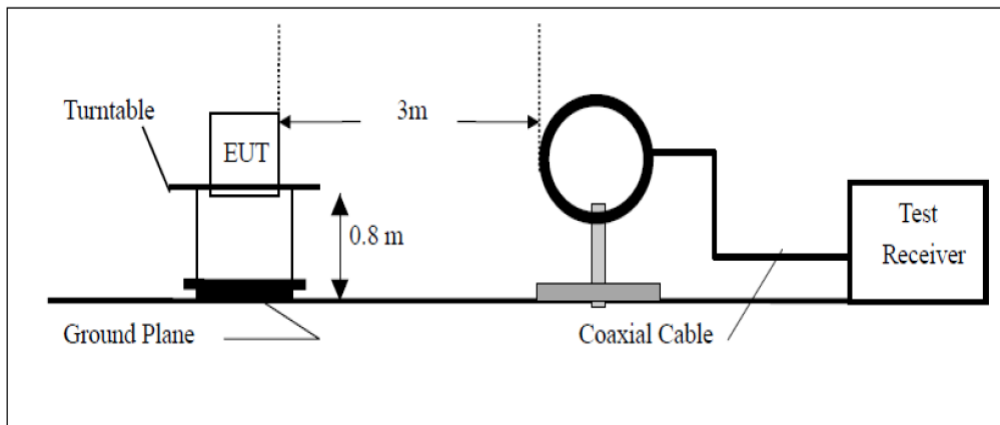
7.1 Radiated test setups 9kHz-30MHz



7.2 Radiated test setups 30MHz-1GHz

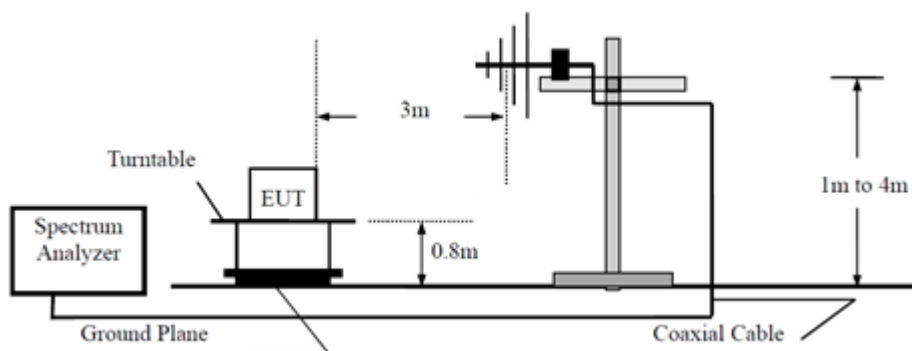

7.3 Radiated test setups Above 1GHz

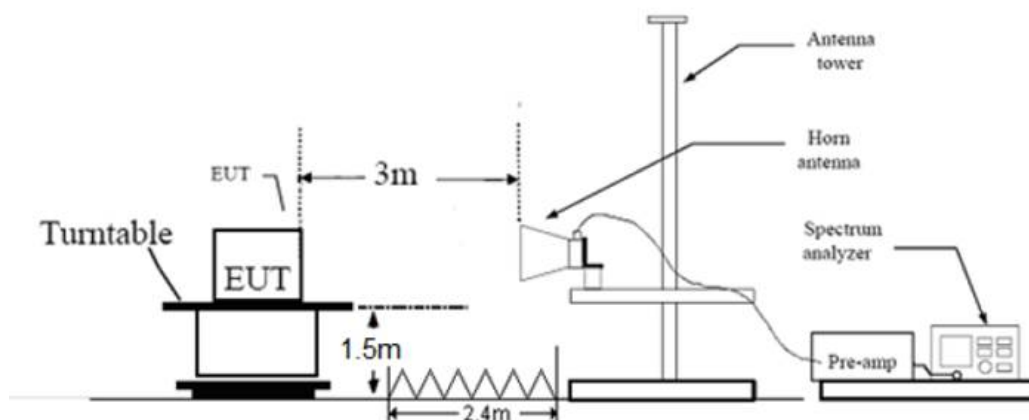

7.4 AC Power Line Conducted Emission test setups

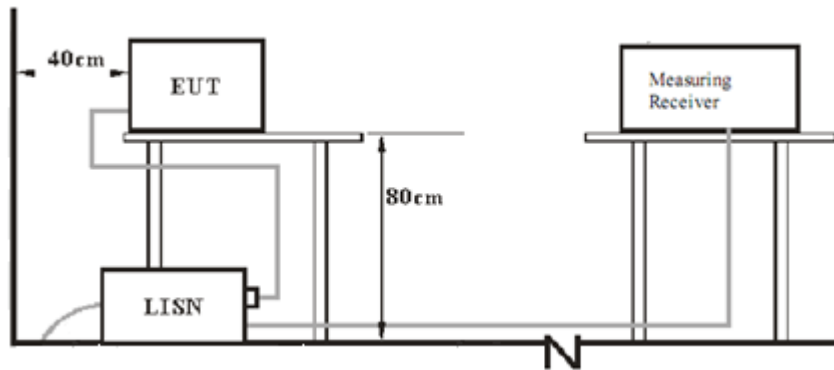

7.5 Conducted RF test setups

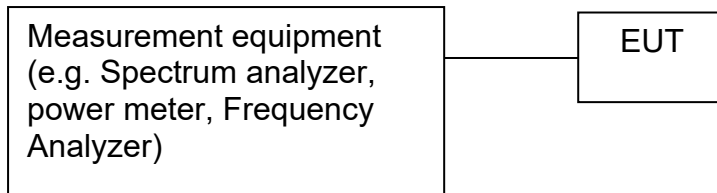

8 Emission Test Results

8.1 Spurious Radiated Emission

EUT: FREEDOM FOCUS
 Op Condition: Operated, TX Mode
 Test Specification: FCC15.205, 15.209
 Comment: 120V AC
 Remark: 9kHz to 30MHz

Test Result	
<input checked="" type="checkbox"/>	Passed
<input type="checkbox"/>	Not Passed

Frequency MHz	Result dB μ V/m	Limit dB μ V/m	Over Limit dB	Detector PK/QP/AV	Corr. (dB)	RSE. or Fund.
0.009000	55.74	128.52	-72.78	Peak	20.03	Spurious emission
0.023993	60.04	120.00	-59.96	Peak	19.72	Spurious emission
0.039973	56.80	115.57	-58.77	Peak	19.69	Spurious emission
0.056000	54.86	112.64	-57.78	Peak	19.70	Spurious emission
0.071980	53.64	110.46	-56.82	Peak	19.69	Spurious emission
0.088007	52.81	108.71	-55.90	Peak	19.69	Spurious emission
0.103987	52.25	107.26	-55.01	Peak	19.69	Spurious emission
0.120014	51.76	106.02	-54.26	Peak	19.68	Spurious emission
0.125000	58.22	105.67	-47.45	Peak	19.67	Fundamental
0.135994	50.51	104.93	-54.42	Peak	19.66	Spurious emission
1.975825	37.50	69.50	-32.00	Peak	19.74	Spurious emission

Remark:

- According to C63.10, if the peak measured value complies with the quasi-peak limit, it is unnecessary to perform a quasi-peak measurement, so quasi-peak emission value did not show in data table if the peak value complies with quasi-peak limit.
- Consequence Level=Reading Level + Correction Factor
 Above 1GHz: Corrector factor = Antenna Factor + Cable Loss- Amplifier Gain
 Below 1GHz: Corrector factor = Antenna Factor + Cable Loss
 (The Reading Level is recorded by software which is not shown in the sheet)
- The testing was performed at 3m distance, the limit has been transferred from 300m/30m to 3m.

Spurious Radiated Emission

EUT: FREEDOM FOCUS
 Op Condition: Operated, TX Mode
 Test Specification: FCC15.205, 15.209
 Comment: 120V AC
 Remark: 30MHz to 1GHz, Antenna: Horizontal

Test Result	
<input checked="" type="checkbox"/>	Passed
<input type="checkbox"/>	Not Passed

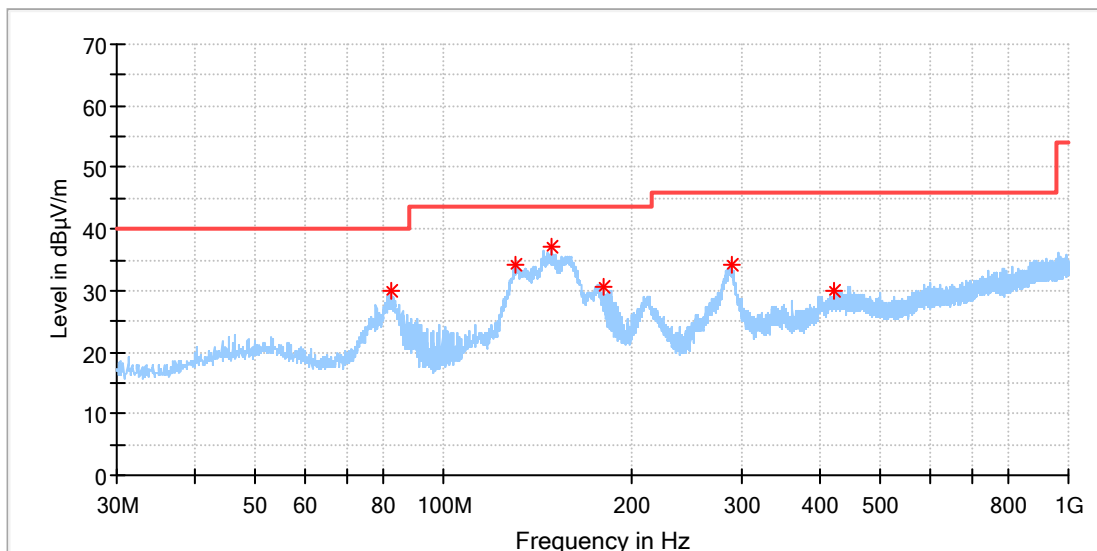

Frequency (MHz)	MaxPeak (dBµV/m)	Limit (dBµV/m)	Over Limit (dB)	Corr. (dB)
82.258750	29.80	40.00	-10.20	11.68
130.819375	34.03	43.50	-9.47	13.16
148.764375	37.23	43.50	-6.27	12.70
180.895625	30.77	43.50	-12.73	14.50
288.929375	34.02	46.00	-11.98	18.44
421.395000	29.80	46.00	-16.20	21.91

Spurious Radiated Emission

EUT: FREEDOM FOCUS
 Op Condition: Operated, TX Mode
 Test Specification: FCC15.205, 15.209
 Comment: 120V AC
 Remark: 30MHz to 1GHz, Antenna: Vertical

Test Result	
<input checked="" type="checkbox"/>	Passed
<input type="checkbox"/>	Not Passed

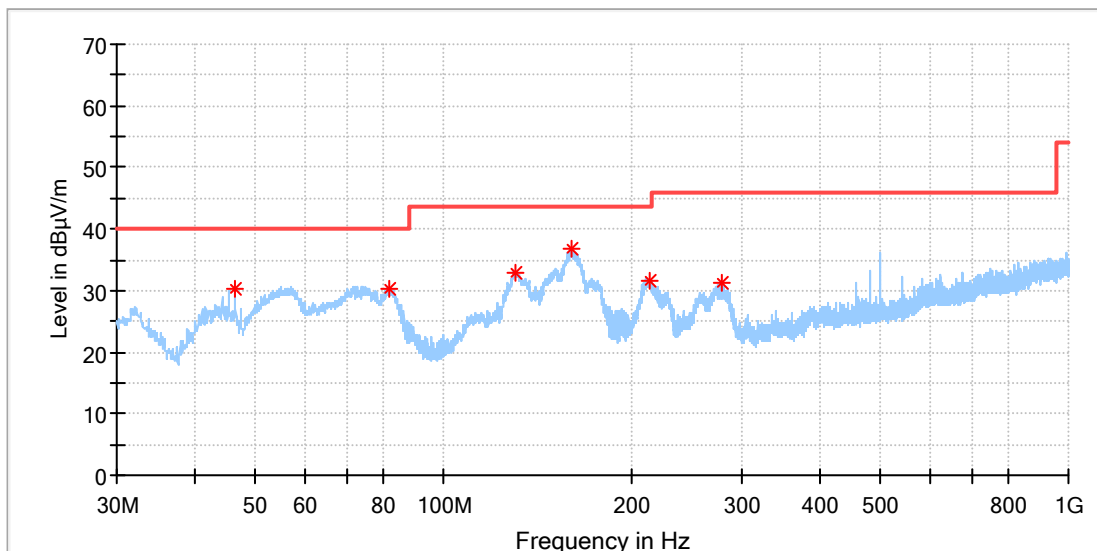

Frequency (MHz)	MaxPeak (dBµV/m)	Limit (dBµV/m)	Over Limit (dB)	Corr. (dB)
46.368750	30.17	40.00	-9.83	17.78
81.955625	30.39	40.00	-9.61	11.60
130.819375	33.02	43.50	-10.48	13.16
160.404375	36.94	43.50	-6.56	13.18
213.269375	31.64	43.50	-11.86	16.62
277.835000	31.18	46.00	-14.82	18.10

8.2 Conducted Emission at AC Power Line

EUT: FREEDOM FOCUS
 Op Condition: 125kHz Working and USB full load
 Test Specification: AC Mains, L Line
 Comment: 120V AC, 60Hz

Test Result	
<input checked="" type="checkbox"/>	Passed
<input type="checkbox"/>	Not Passed

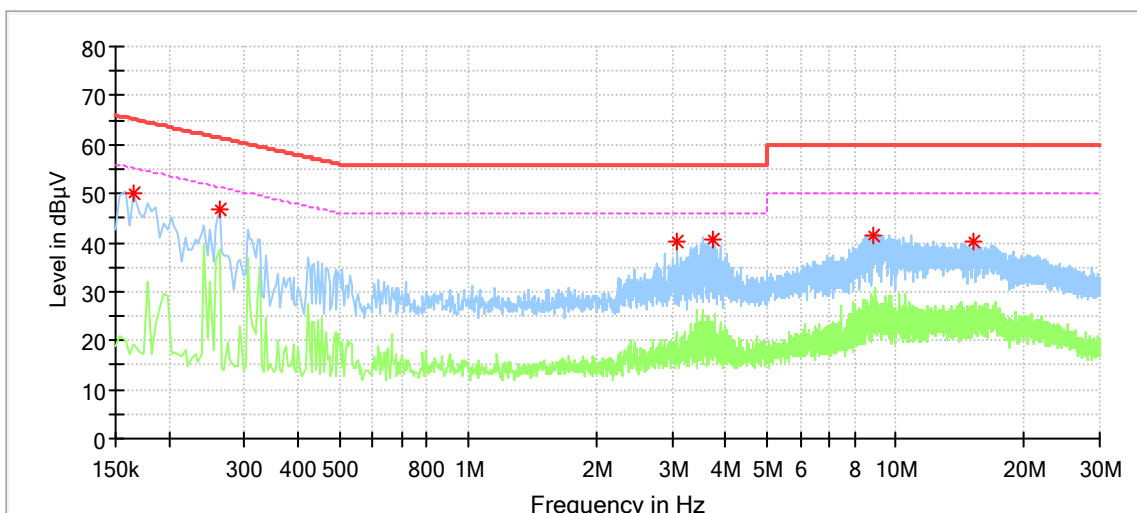

Frequency (MHz)	MaxPeak (dBµV)	Average (dBµV)	Limit (dBµV)	Over Limit (dB)	Corr. (dB)
0.166000	50.22	---	65.16	-14.94	9.64
0.262000	46.71	---	61.37	-14.66	9.64
3.094000	40.04	---	56.00	-15.96	9.71
3.722000	40.57	---	56.00	-15.43	9.73
8.898000	41.51	---	60.00	-18.49	9.87
15.126000	40.27	---	60.00	-19.73	9.89

Conducted Emission Test

EUT: FREEDOM FOCUS
 Op Condition: 125kHz Working and USB full load
 Test Specification: AC Mains, N Line
 Comment: 120V AC, 60Hz

Test Result	
<input checked="" type="checkbox"/>	Passed
<input type="checkbox"/>	Not Passed

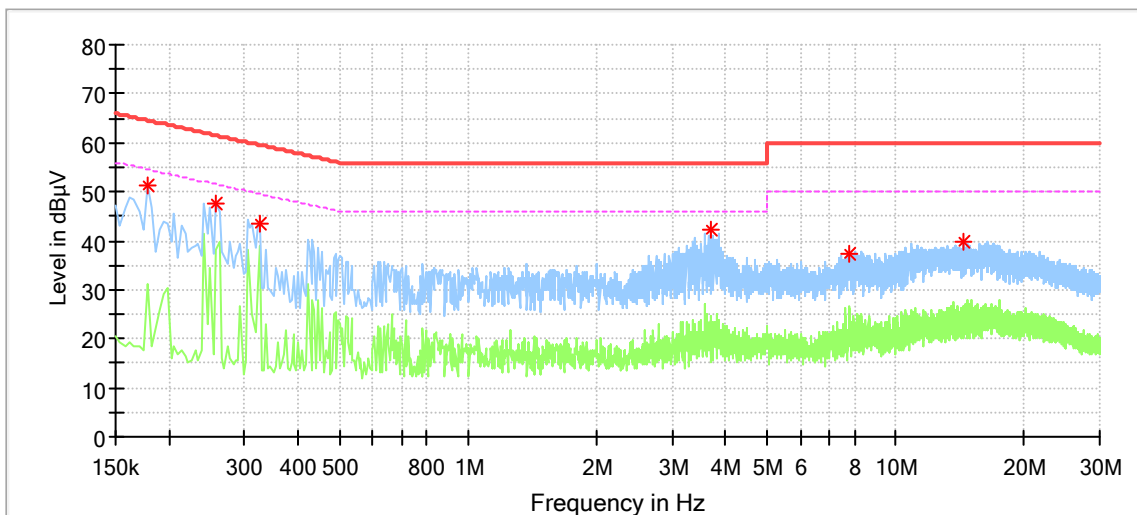

Frequency (MHz)	MaxPeak (dBµV)	Average (dBµV)	Limit (dBµV)	Over Limit (dB)	Corr. (dB)
0.178000	51.35	---	64.58	-13.23	9.62
0.258000	47.39	---	61.50	-14.11	9.63
0.326000	43.41	---	59.55	-16.14	9.63
3.706000	42.43	---	56.00	-13.57	9.72
7.826000	37.49	---	60.00	-22.51	9.84
14.370000	39.89	---	60.00	-20.11	9.89

8.3 6dB & 99% Bandwidth

EUT: FREEDOM FOCUS
 Op Condition: Operated, TX Mode
 Test Specification: FCC15.215, 20dB Bandwidth
 Comment: 120V AC

Test Result	
<input checked="" type="checkbox"/>	Passed
<input type="checkbox"/>	Not Passed

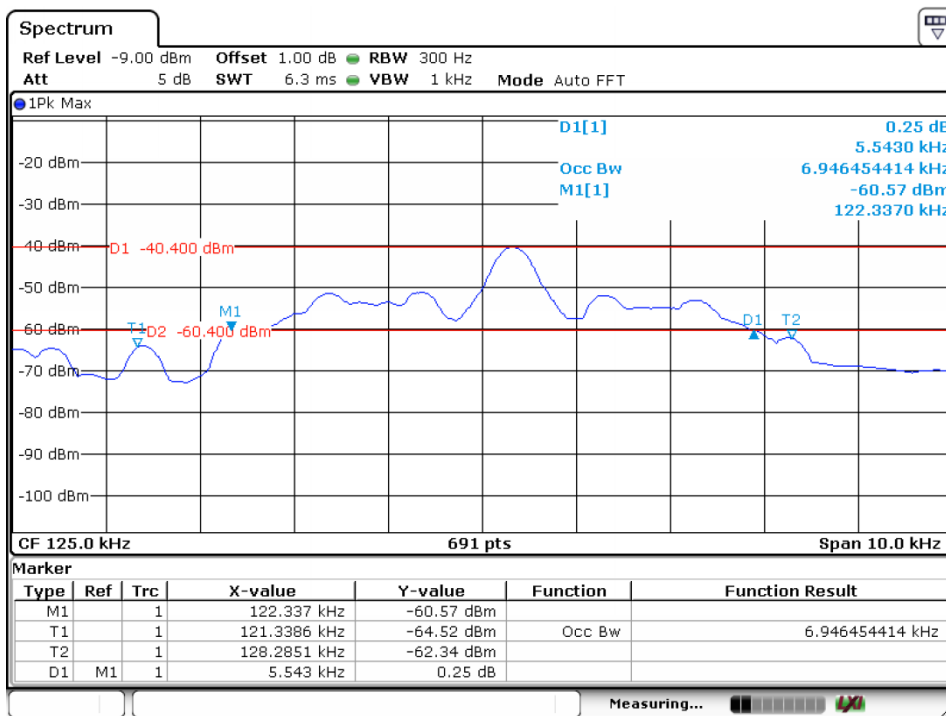

Date: 7.JAN.2021 14:05:02

Bandwidth	Measured Value
20dB bandwidth	5.5 kHz
99% bandwidth	6.9 kHz

9 Test setup procedure

9.1 Field strength of emissions and Restricted bands

Test Method

- 1: The EUT was placed on a turn table which is 1.5m above ground plane for above 1GHz and 0.8m above ground for below 1GHz at 3-meter chamber room for test. The table was rotated 360 degrees to determine the position of the highest radiation.
- 2: The EUT was set 3 meters away from the interference – receiving antenna, which was mounted on the top of a variable – height antenna tower.
- 3: The height of antenna is varied from one meter to four meters above the ground to determine the maximum value of the field strength. Both horizontal and vertical polarizations of the antenna are set to make the measurement.
- 4: For each suspected emission, the EUT was arranged to its worst case and then the antenna was tuned to heights from 1 meter to 4 meters and the rotatable table was turned from 0 degrees to 360 degrees to find the maximum reading.
- 5: Use the following spectrum analyzer settings According to C63.10:

For Above 1GHz

Span = wide enough to capture the peak level of the in-band emission and all spurious
RBW = 1MHz, VBW \geq 3RBW, Sweep = auto, Detector function = peak and average,
Trace = max hold.

For Below 1GHz

Use the following spectrum analyzer settings:

Span = wide enough to capture the peak level of the in-band emission and all spurious
RBW = 120KHz, VBW \geq 3RBW, Sweep = auto, Detector function = QP,
Trace = max hold.

Field strength of emissions and Restricted bands

Limits

According to §15.209 (a), the field strength of emissions from intentional radiators shall not exceed the field strength levels specified in the following table:

Fundamental frequency (MHz)	Field strength (microvolts/meter)	Field strength of harmonics (microvolts/meter)
0.009-0.490	2400/F(kHz)	300
0.490-1.705	24000/F(kHz)	30
1.705-30.0	30	30
30-88	100	3
88-216	150	3
216-960	200	3
Above 960	500	3

9.2 Conducted Emission at AC Power line

Test Method

1. The EUT was placed on a table, which is 0.8m above ground plane
2. The power line of the EUT is connected to the AC mains through a Artificial Mains Network (A.M.N.).
3. Maximum procedure was performed to ensure EUT compliance
4. A EMI test receiver is used to test the emissions from both sides of AC line

Limit

Frequency MHz	QP Limit dB μ V	AV Limit dB μ V
0.150-0.500	66-56*	56-46*
0.500-5	56	46
5-30	60	50

*Decreasing linearly with logarithm of the frequency.

9.3 20dB & 99% Bandwidth

Test Method

1. Check the calibration of the measuring instrument using either an internal calibrator or a known signal from an external generator.
2. Position the EUT without connection to spectrum analyser. Turn on the EUT and connect it to measurement instrument. Then set it to any one convenient frequency within its operating range. Set a reference level on the measuring instrument equal to the highest peak value.
3. Measure the frequency difference of two frequencies that were attenuated 20dB from the reference level. Record the frequency difference as the emission bandwidth.

Limits:

According to 15.215 (c) Intentional radiators operating under the alternative provisions to the general emission limits, as contained in §§ 15.217 through 15.257 and in Subpart E of this part, must be designed to ensure that the 20 dB bandwidth of the emission, or whatever bandwidth may otherwise be specified in the specific rule section under which the equipment operates, is contained within the frequency band designated in the rule section under which the equipment is operated. The requirement to contain the designated bandwidth of the emission within the specified frequency band includes the effects from frequency sweeping, frequency hopping and other modulation techniques that may be employed as well as the frequency stability of the transmitter over expected variations in temperature and supply voltage. If a frequency stability is not specified in the regulations, it is recommended that the fundamental emission be kept within at least the central 80% of the permitted band in order to minimize the possibility of out-of-band operation.

10 Appendix A - General Product Information

Radiofrequency radiation exposure evaluation

This exposure evaluation is intended for **FCC ID: 2AA2X-15000256**.

According to KDB 447498 D01v06 section 4.3.1, For frequencies below 100 MHz and test separation distances ≤ 50 mm, the Numeric threshold is determined as:

Step a)

$[(\text{max. power of channel, including tune-up tolerance, mW}) / (\text{min. test separation distance, mm})] \cdot [\sqrt{f(\text{GHz})}] \leq 3.0$
for 1-g SAR

Step b)

$\{[\text{Power allowed at numeric threshold for 50mm in step a)}] + [(\text{test separation distance} - 50\text{mm}) \cdot (f(\text{MHz})/150)]\}$
mW

Step c) 1)

For test separation distances $> 50\text{mm}$ and $< 200\text{mm}$, the power threshold at the corresponding test separation distance at 100MHz in step b) is multiplied by $[1 + \log(100/f(\text{MHz}))]$

Step c) 2)

For test separation distances $\leq 50\text{mm}$, the power threshold determined by the equation in c) 1) for 50mm and 100MHz is multiplied by $\frac{1}{2}$.

>> The fundamental frequency of the EUT is 125kHz, the test separation distance is $\leq 50\text{mm}$.
(Manufacturer specified the separation distance is: 20mm)

Step a)

>> Numeric threshold, $\text{mW} / 50\text{mm} \cdot \sqrt{0.1\text{GHz}} \leq 3.0$
Numeric threshold $\leq 474.3\text{mW}$

Step b)

>> Numeric threshold $\leq 474.3\text{mW} + (50\text{mm} - 50\text{mm}) \cdot 100\text{MHz}/150$
Numeric threshold $\leq 474.3\text{mW}$

Step c) 1) & c) 2)

>> Numeric threshold $\leq 474.3\text{mW} \cdot [1 + \log 100/100\text{MHz}] \cdot \frac{1}{2}$
Numeric threshold $\leq 237.15\text{mW}$

>> The power (calculated power + tune up tolerance) of EUT at 125kHz is: 0.0008mW
Which is smaller than the Numeric threshold.
Therefore, the device is exempt from stand-alone SAR test requirements.

Appendix A

Power calculation (According to C63.10 chapter 9.5)

	Value	Unit
Field Strength Measured (E)	58.22	dB μ V/m
Measurement Distance (D)	3	m
Equivalent Isotropically Radiated Power (E.I.R.P in dBm)	-36.94	dBm
Equivalent Isotropically Radiated Power (E.I.R.P in mW)	0.0002	mW

Remark: $EIRP = E + 20\log(D) - 104.7$

(EIRP is in dBm, E is in dB μ V/m, D is in meters)

Reviewed by:

Prepared by:



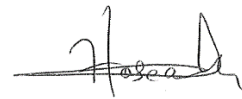

Eric LI
EMC Project Manager

Hosea CHAN
EMC Project Engineer