

- 1** **NOTE:** This device requires professional installation to prevent tampering with or removal/replacement of the antenna by anyone other than qualified service professionals.

Choose an appropriate location, preferably on the ceiling, within 70 ft of the MTI Connect® Hub or another network extender.

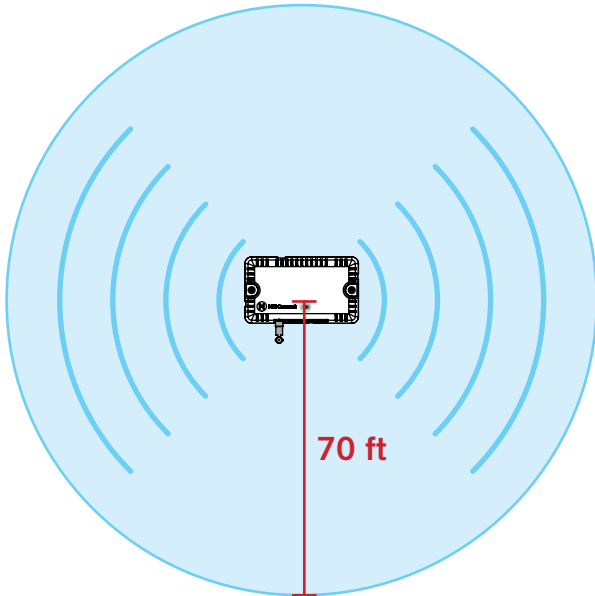

- 2** **NOTE:** PoE Network Extender must be powered by an ES1 (<60 VDC) and PS1 (<15W) PoE power source. Passive and Active PoE adapters are supported.

Run a Cat5e cable to the chosen location. Cable must be terminated with an RJ-45 Connector following TIA-568 A/B standards. Connect one end of the cable to a PoE adapter.

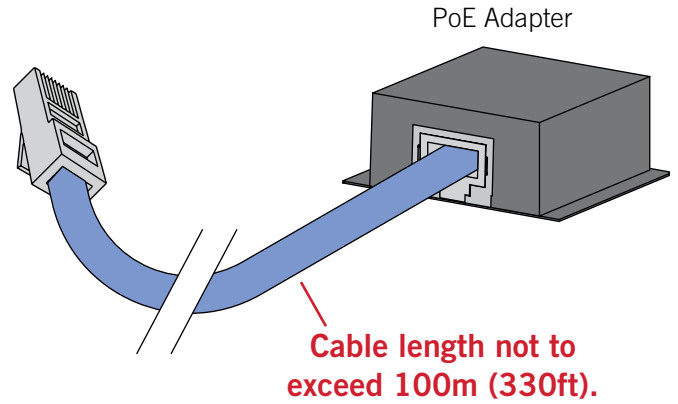

- 3** **NOTE:** Cat5e cables and PoE devices should be installed by certified professionals, following installation standards defined by local electrical code.

Plug the Cat5e cable's RJ-45 connector into the PoE Network Extender's RJ-45 jack and route the cable as desired, using the provided cable channels if needed.

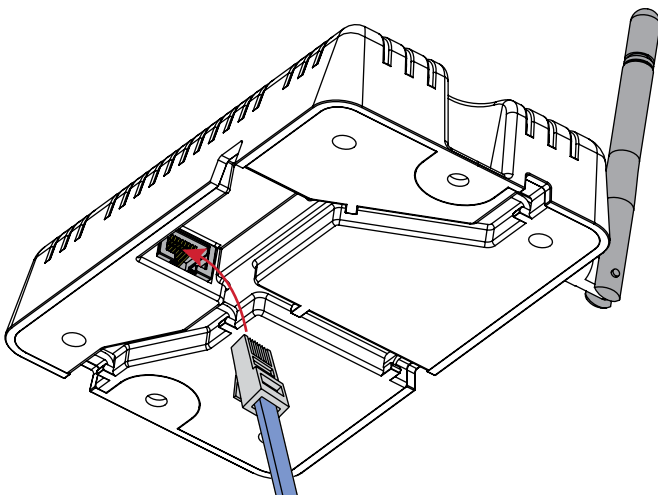

- 4** Mount the extender using the 3.5 mm x 16 mm screws (or longer if needed) for the mounting surface (not included).

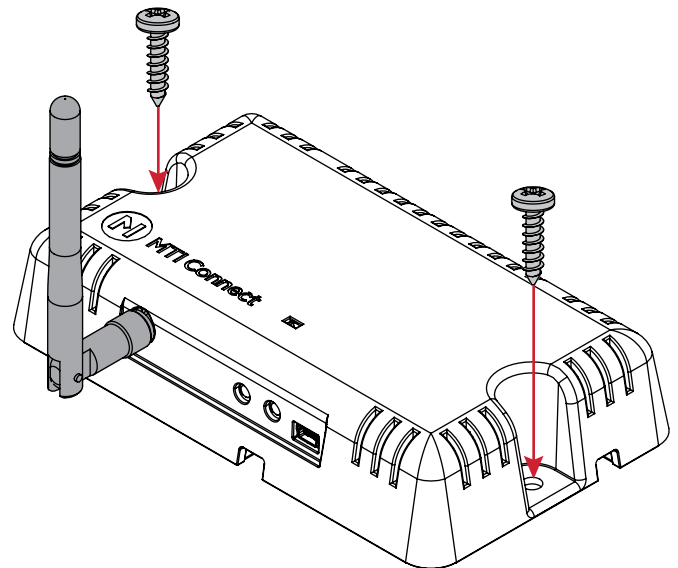

- 1 Place the MTI Connect® Hub in pairing mode by inserting an MTI Connect® Unified IntelliKey into the USB Mini connector on the top of the MTI Connect® Hub. After 10 seconds the System Status LED will begin flashing blue, indicating the Hub is in Pairing mode.

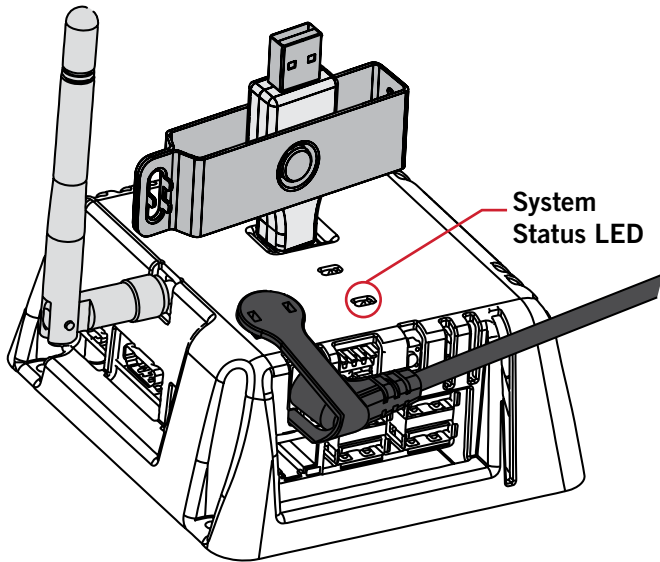

**⚠ The MTI Connect® Hub will automatically exit pairing mode after 15 minutes and it's status LED will return to the previous state.**

- 2 Press the recessed Pairing Button (labeled) shown below for two seconds. The Network Extender Status LED will begin flashing blue, indicating it has entered pairing mode.

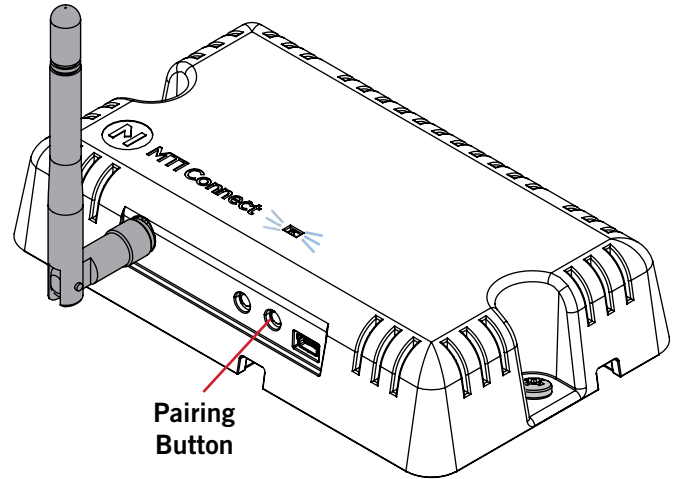

- 3 When the Network Extender attaches to the mesh network, the blue flashing LED will become solid Green. If the Network Extender does not connect to a mesh network within 90 seconds, it will exit pairing mode and will return to its previous state.

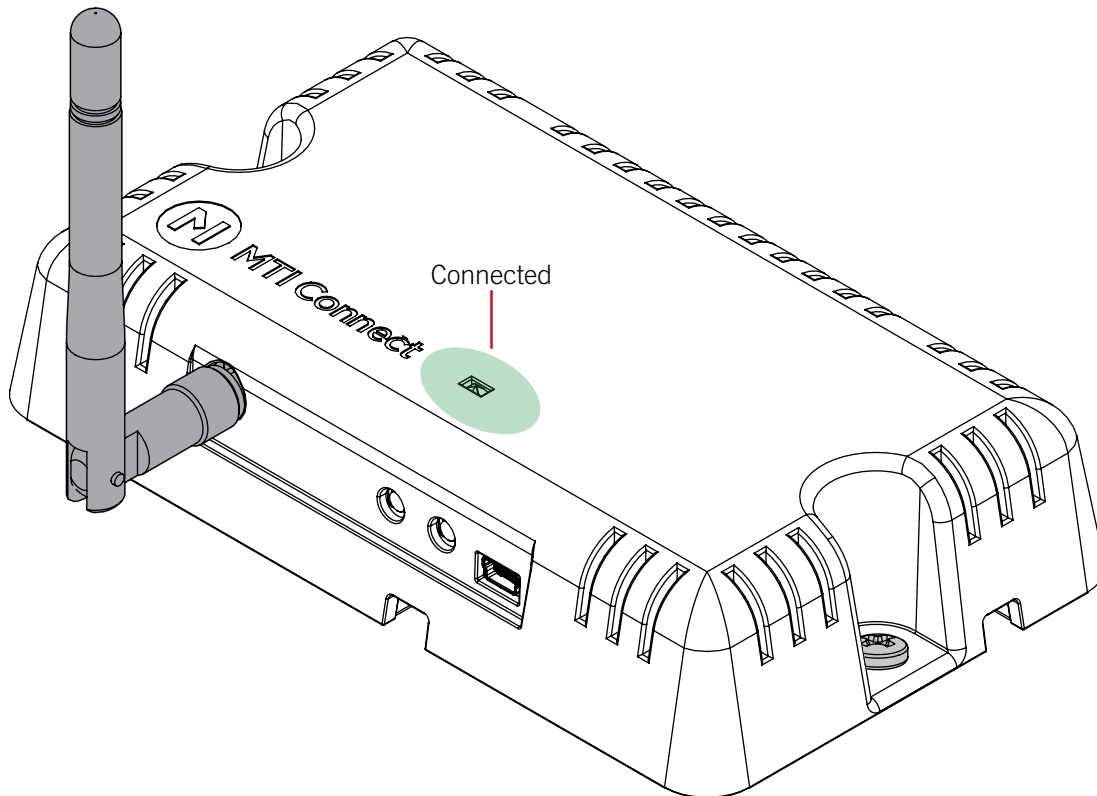

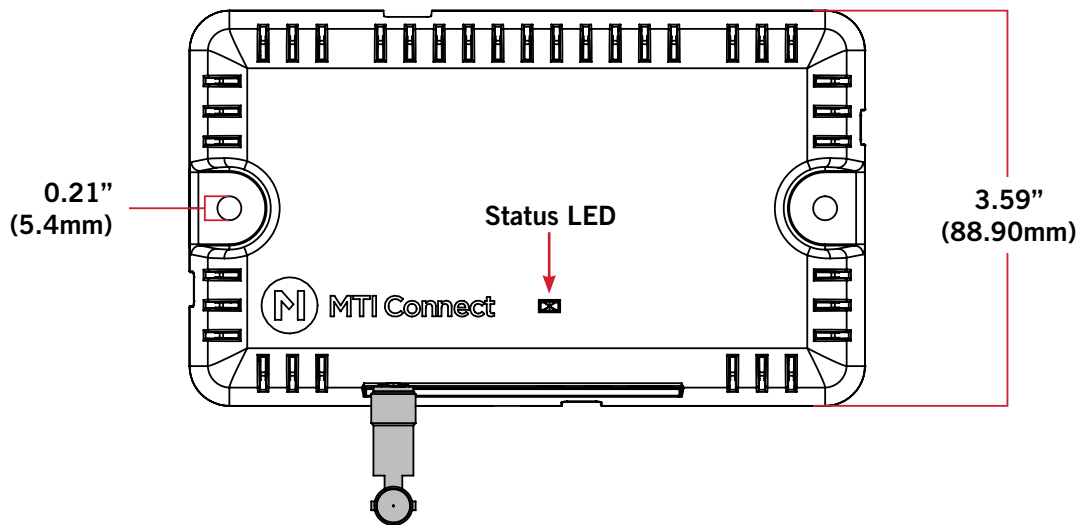
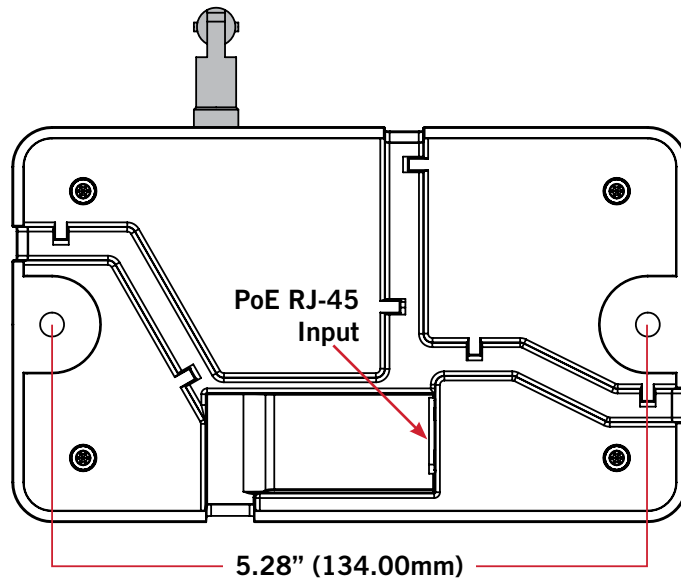
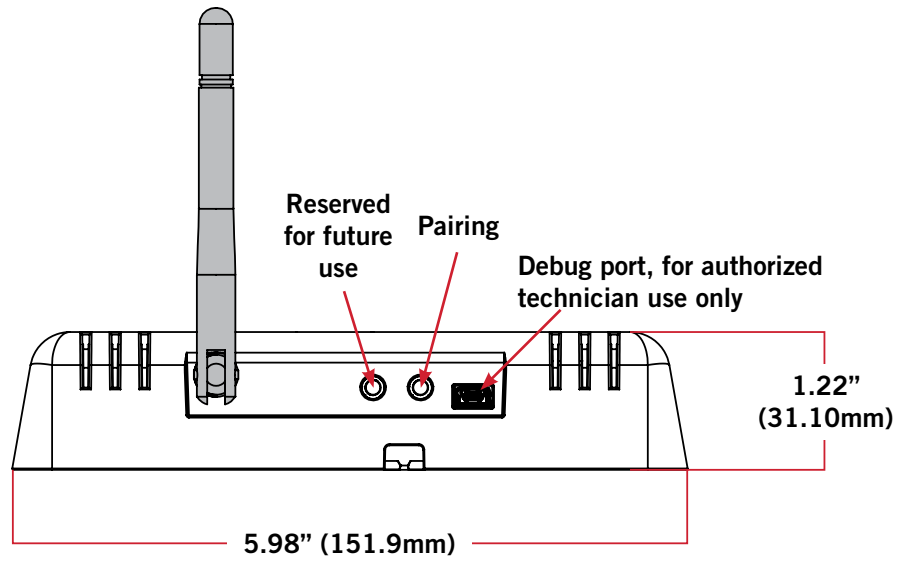

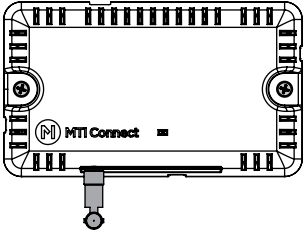
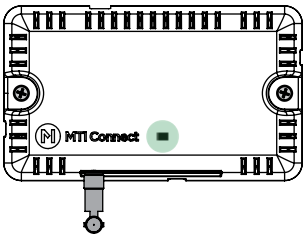
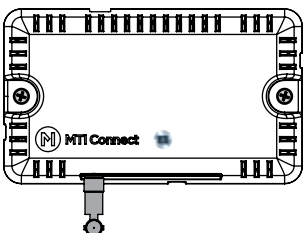
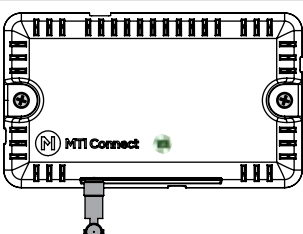
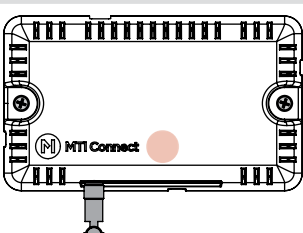
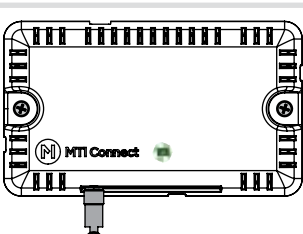
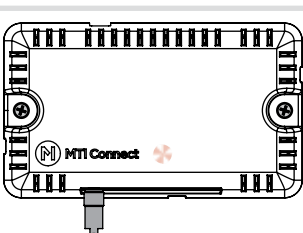
Visual Reference	System Status	Condition
	No Lights On	Network Extender has no power and backup battery has been depleted. Reconnect Network Extender to power.
	Status LED Solid Green	Network Extender is fully functional: – Mesh network communication is good
	Status LED Flashing Blue	Network Extender is in mesh pairing mode.
	Status LED Flashing Green	Currently communicating on mesh network, but has had communication issues within the last 24 hours.
	Status LED Solid Red	No communication with mesh network; Either has never been paired or has lost communication with the mesh network.
	Status LED Flashing Green once every 10 seconds	Network Extender is in battery backup mode and is communicating with the mesh network - connect to power.
	Status LED Flashing Red once every 10 seconds	Network Extender is in battery backup mode and is not communicating with the mesh network - connect to power.

**FCC ID: 2AA2X-15000242**  
**Model: PoE Network Extender**  
**FCC Statement**

This device complies with Part 15 of the FCC Rules.

Caution: If any changes or modifications not expressly approved by the party responsible for compliance could void the user's authority to operate the equipment.

Operation is subject to the following two conditions: (1) This device may not cause harmful interference, and (2) This device must accept any interference received, including interference that may cause undesired operation.

The grantee is not responsible for any changes or modifications not expressly approved by the party responsible for compliance. Such modifications could void the user's authority to operate the equipment.

The RF Exposure Compliance distance is 20 centimeters.

NOTE: This equipment has been tested and found to comply with the limits for a Class B digital device, pursuant to part 15 of the FCC Rules. These limits are designed to provide reasonable protection against harmful interference in a residential installation. This equipment generates, uses and can radiate radio frequency energy and, if not installed and used in accordance with the instructions, may cause harmful interference to radio communications. However, there is no guarantee that interference will not occur in a particular installation. If this equipment does cause harmful interference to radio or television reception, which can be determined by turning the equipment off and on, the user is encouraged to try to correct the interference by one or more of the following measures:

- Reorient or relocate the receiving antenna.
- Increase the separation between the equipment and receiver.
- Connect the equipment into an outlet on a circuit different from that to which the receiver is connected.
- Consult the dealer or an experienced radio/TV technician for help.

**ISED Certification Number: 24439-15000242**  
**Model: PoE Network Extender**  
**ISED Statement**

This device complies with Innovation, Science and Economic Development Canada licence-exempt RSS standard(s). Operation is subject to the following two conditions: (1) this device may not cause interference, and (2) this device must accept any interference, including interference that may cause undesired operation of the device.

CAN ICES-3(B)/NMB-3(B)

Le présent appareil est conforme aux CNR Innovation, Sciences et Développement économique Canada applicables aux appareils radio exempts de licence. L'exploitation est autorisée aux deux conditions suivantes:

(1) il ne doit pas produire de brouillage et (2) l'utilisateur du dispositif doit être prêt à accepter tout brouillage radioélectrique reçu, même si ce brouillage est susceptible de compromettre le fonctionnement du dispositif.

CAN ICES-3(B)/NMB-3(B)

The device meets the exemption from the routine evaluation limits in section 2.5 of RSS 102 and compliance with RSS-102 RF exposure, users can obtain Canadian information on RF exposure and compliance.

Le dispositif rencontre l'exemption des limites courantes d'évaluation dans la section 2.5 de RSS 102 et la conformité à l'exposition de RSS-102 rf, utilisateurs peut obtenir l'information canadienne sur l'exposition et la conformité de rf.

This transmitter must not be co-located or operating in conjunction with any other antenna or transmitter. This equipment should be installed and operated with a minimum distance of 20 centimeters between the radiator and your body.

Cet émetteur ne doit pas être Co-placé ou ne fonctionnant en même temps qu'aucune autre antenne ou émetteur. Cet équipement devrait être installé et actionné avec une distance minimum de 20 centimètres entre le radiateur et votre corps.

**Technical Data**

Operating Frequency:	2405 MHz to 2480 MHz
Operating Temperature:	0°C to 40°C
Max Power:	Less than 20dBm at 2.4 GHz

**Additional Safety Information**

1. For indoor use only. The apparatus shall not be exposed to water.
2. No user replaceable parts inside; refer servicing to manufacturer or qualified service personnel.
3. Only use accessories specified by the manufacturer.
4. Do not expose to excessive heat sources.

Disposal: All electrical and electronic products including batteries should be disposed of separately from the municipal waste stream via designated collection facilities appointed by the government or the local authorities.



This product contains a rechargeable battery. Proper storage, use, and disposal of the battery is important. Please refer to the guidelines below:

- i. Properly dispose of the battery; Do not dispose of the battery into a furnace/oven or into a fire or mechanically crush or cut the battery, as this could cause the battery to explode.
- ii. Storing the battery in an environment at higher temperatures than stated above can result in explosion or leaking of flammable liquid or gas.
- iii. Subjecting a battery to very low air pressure or high altitudes can result in explosion or leaking of flammable liquid or gas.