

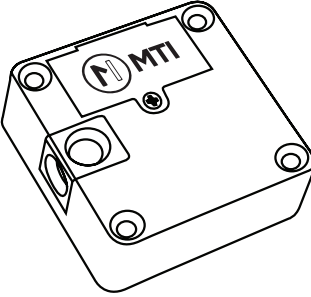

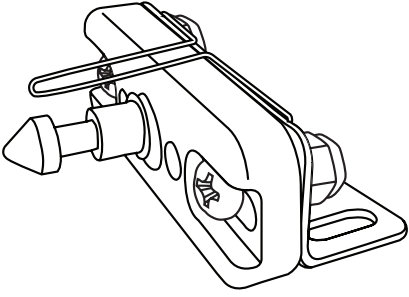



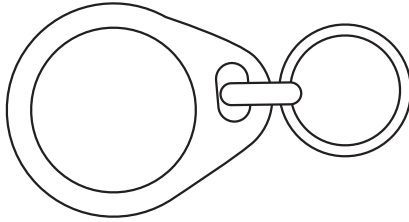

<p>Door/Drawer Lock - 165-00444</p> 	<p>Strike Plate - 165-00383</p> 	<p>Authorization Card - 401-00002</p>  <p> Sold separately.</p>
<p>User Key - 401-00001</p>  <p> Sold separately.</p>	<p>Battery - 410-00003</p>  <p>Use #1 Phillips screwdriver</p> <p> Use only CR-123 / 3VDC batteries.</p>	<p>Screw Kit - 010-00011</p> 

DOOR/DRAWER INSTALLATION

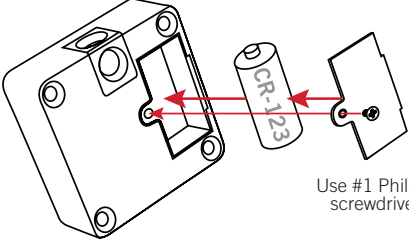
 **NOTES BEFORE INSTALLING:** Space devices at least 4" apart. Install the lock using hand tools only. Use of power tools could lead to damage of the fixture. Uninstalled locks should be stored without batteries. Operating temp.: 41-95° F.

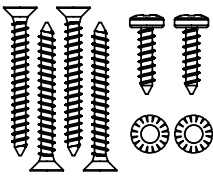
Required Items:

- #1 Phillips Screwdriver
- #2 Phillips Screwdriver
- 3/32" Drill Bit
- 9/32" Socket (Optional)

See the last page of this manual for a mounting template.

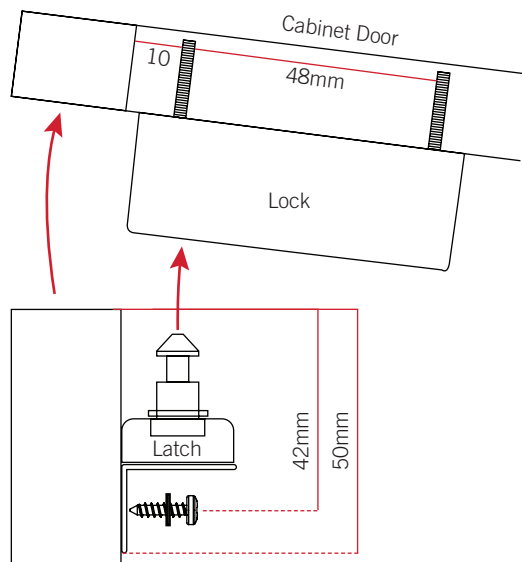

Sliding Doors Install

For sliding doors, the 90° bracket can be removed from the latch (using the #2 Phillips Screwdriver and the 9/32" socket) and hard mounted to a fixture with wood screws.

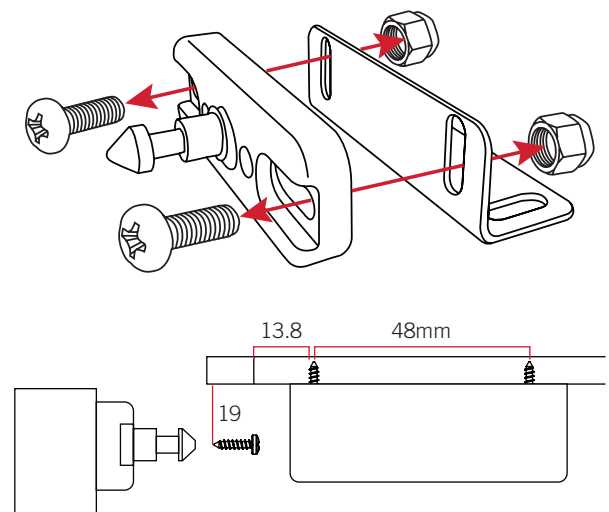

After install, but before closing the door/drawer, be sure to program locks.

Once programmed, swipe programmed key on lock to test the lock. The lock motor should spin, opening the lock.

Note: If the lock emits a slow, low beep tone, then the motor is stuck due to overtightening the mounting screws. Slowly unscrew the screw to the left of the battery door (when the MTI logo is right-side-up) one-quarter turn at a time until the motor can spin, opening the lock.

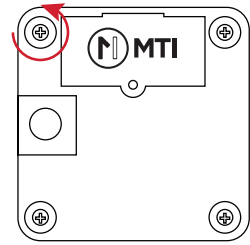

USING THE DOOR/DRAWER LOCK

Door/Drawer Locks (For initial lock setup prior to use, please see page 4):

Place the User Key within 30 mm of where the lock is placed. One you hear a click, open the door or drawer. Close door or drawer to relock.



Self-closing hinges may prevent proper function of the door/drawer lock.



Door Open Mode

If a door/drawer has been left open for 5 minutes, the lock will emit a continuous on and off beep tone for 10 minutes or until the door is closed.

Stuck Lock:

If a lock is jammed or unable to unlock, the lock will emit a slow beep tone to indicate that the lock is stuck.





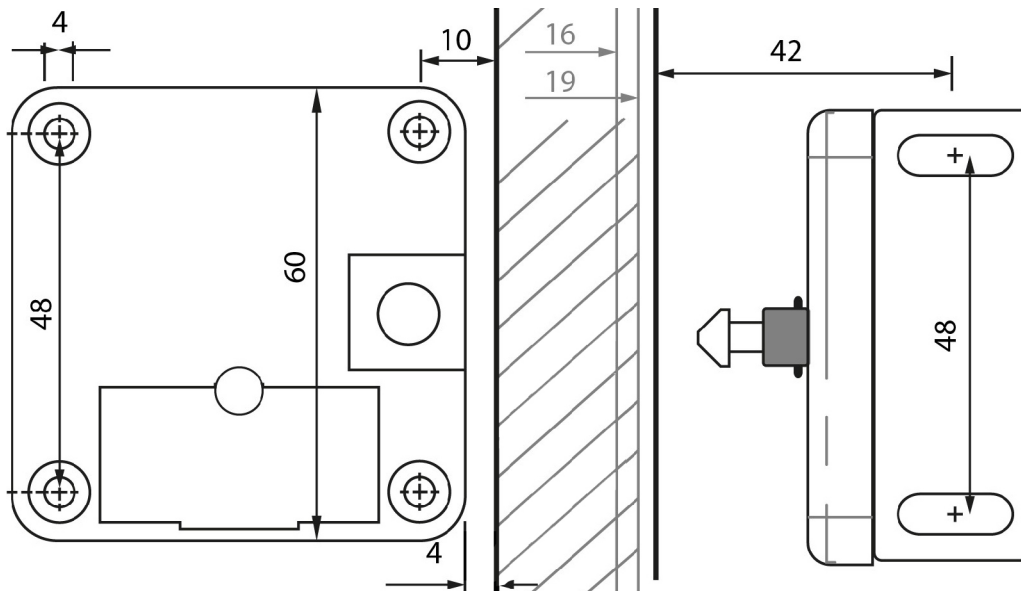

Low Battery:

If the lock battery is low and needs replacement, the lock will emit a long single beep on every key swipe.

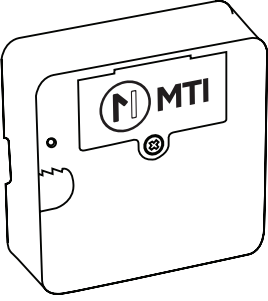
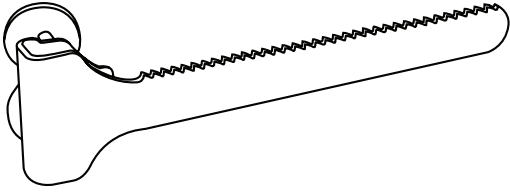
MOUNTING TEMPLATE

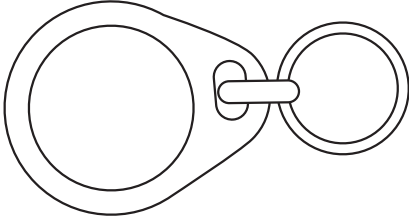
Print or Photocopy at 100% to assist in placing the Door/Drawer Lock.

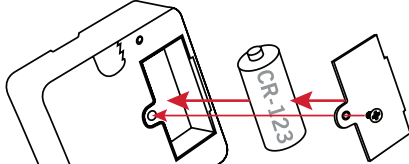

<p>GlassDoor Lock - 165-00445</p> 		<p>Glass Latch Bracket</p> <p>Thin (3-10mm) - 165-00476 or Thick (10-19mm) - 165-00477</p> 	
<p>Authorization Card - 401-00002</p>  <p> Sold separately.</p>	<p>User Key - 401-00001</p>  <p> Sold separately.</p>	<p>Battery - 410-00003</p>  <p>Use #1 Phillips screwdriver</p> <p> Use only CR-123 / 3VDC batteries.</p>	

GLASS DOOR INSTALLATION & USE

 **NOTES BEFORE INSTALLING:** Space devices at least 4" apart.

- Slide the lock mount over the back sliding glass door while it is in its closed position.

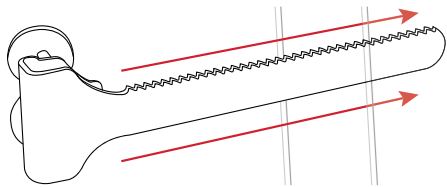

- Tighten the knobs on the back of the mount.

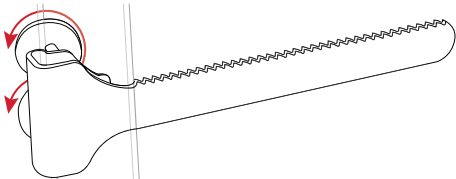

- Slide the front glass door into its closed position and slide the lock over the lock mount blade.

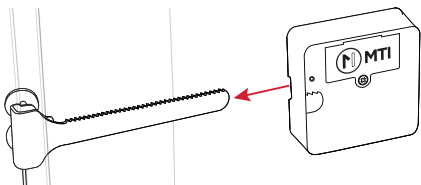

Using the Glass Door Locks:

Place the User Key on the lock. Once you hear a click, slide the lock off of the Glass Latch Bracket to slide the glass doors open. Slide the glass doors closed and replace the lock on the Latch Bracket to relock.



Entering Registration Mode (Initial Setup)

1. Swipe Authorization Card on the Lock (this will be the Authorization Card's ID in the lock's memory). The lock will emit 2 double beeps, indicating the lock is ready to receive User Keys.
2. Each lock will stay in registration mode until it is closed with a swipe of the Authorization Card (emitting 2 quadruple beeps to indicate a closed session) or is left idle for 3 minutes.

Registering User Keys to Each Lock

1. Individually swipe each User Key (up to 251) over the lock until all User Keys have been entered into the lock's whitelist.
 - a. After each User Key swipe, the lock will emit a 2 beep ascending tone to confirm the key has been added.
 - b. Should a User Key add error occur, the lock will emit 4 fast beeps to indicate a key add error.
2. Swipe Authorization Card to close the registration session.

Deleting User Keys Whitelist on Locks

1. Place Authorization Card on the lock for 5 seconds until it emits a slow ticking signal.
2. Remove Authorization Card (ticking will continue).
3. Swipe the Authorization Card on the lock during this period to delete the entire whitelist of User Keys.
 - a. Lock will delete the whitelist and then emit an ascending 2 beep tone, indicating success.
 - b. Should a User Key delete error occur, the lock should emit 4 fast beeps to indicate a key delete error.
 - c. **Note: Authorization Card's information is not deleted.**

Reset Locks to Default Mode

1. Remove lock from installed position
2. Press and hold the button on the back of the lock until it emits a 2 beep ascending tone (~3 seconds).
3. After tone is heard, release button
4. Lock will be reset
 - a. **This deletes all User Keys, including the Authorization Card.**

CAUTIONS



Battery Caution

Risk of explosion if battery is replaced by an incorrect type. Dispose of used batteries according to the instructions.



Correct Disposal of Product



This marking indicates that this product should not be disposed with other household wastes throughout the EU. To prevent possible harm to the environment or human health from uncontrolled waste disposal, recycle it responsibly to promote the sustainable reuse of material resources. To dispose of used devices contact MTI Global Services Contact Center at 503-648-6500 or contact local recycling company for proper recycling instructions for electronic devices.



FCC Statement

This device complies with Part 15 of the FCC Rules.

Operation is subject to the following two conditions: (1) This device may not cause harmful interference, and (2) This device must accept any interference received, including interference that may cause undesired operation.

The grantee is not responsible for any changes or modifications not expressly approved by the party responsible for compliance. Such modifications could void the user's authority to operate the equipment.

The RF Exposure Compliance distance is 20 millimeters.

NOTE: This equipment has been tested and found to comply with the limits for a Class B digital device, pursuant to part 15 of the FCC Rules. These limits are designed to provide reasonable protection against harmful interference in a residential installation. This equipment generates, uses and can radiate radio frequency energy and, if not installed and used in accordance with the instructions, may cause harmful interference to radio communications. However, there is no guarantee that interference will not occur in a particular installation. If this equipment does cause harmful interference to radio or television reception, which can be determined by turning the equipment off and on, the user is encouraged to try to correct the interference by one or more of the following measures:

- Reorient or relocate the receiving antenna.
- Increase the separation between the equipment and receiver.
- Connect the equipment into an outlet on a circuit different from that to which the receiver is connected.
- Consult the dealer or an experienced radio/TV technician for help.