

PHOTON

USER MANUAL



01 SAFETY & PRECAUTION

- General Safety
- Before the Ride
- Installation & Use
- Disclaimer

02 SPECIFICATION

- Description
- Specifications
- Parts List
- Dimensions
- Motor Body Dimensions



General Safety

Kindly read through the entire user manual. This manual contains important information to reduce user risk as well as instructions for this product's proper use. Do not discard the manual but keep it for reference.

Note that the user's personal safety remains the user's responsibility and that the user must contact CYCMotor Ltd or their official product dealer directly for any further guidelines or assistance.

Never interfere with the movable parts when the drive unit is connected to a power supply. This could result in serious injury if the system is accidentally engaged.

This product is a powerful motor system that is dangerous for children and must be handled by an adult at all times. Small components and accessories may also present a choking hazard. Keep the motor system and accessories out of reach from children.

All components and accessories may only be replaced with identical components directly supplied by CYCMotor Ltd or an official product dealer. CYCMotor Ltd cannot be held liable for any damages as a result of using unapproved parts.

This product only complies with local, state, and federal regulations if speed limits are set accordingly. Ensure that you have set up your X1 Stealth kit according to your local, state, and federal regulations when using and registering this drive unit on a public road/area.

Before the Ride

Ensure that the drive unit chain has the proper tension. Incorrect tension could cause jamming of the system and result in injury while riding. Inspect the chain tension regularly.

Ensure that the chains are properly lubricated. Cleaning and lubricating your chain with regular bicycle chain cleaner, is advised regularly.

When connecting a power supply, make sure that the power supply is completely connected. Faulty connection could result in a short circuit and damage the controller or batteries.

Inspect all electrical wires and plugs for damage regularly.

Secure all wires properly. Ensure that no loose wires are dangling from the bike that could be jammed into any moving parts.

Before turning on the system, ensure that the throttle can be twisted freely without friction and that the throttle can return to its original position without restriction. This is to prevent any uncontrolled response of the system.



Installation & Use

Do not install anything other than the parts and accessories that came with this drive unit. Doing so could damage the product.

The drive system can be activated and deactivated by holding down the on/off button on the display.

Avoid changing the bike gear (note: this is different from the drive unit's assist level) while the drive unit is powering the bike. This may lead to excessive wear on the chain and chain rings or other gear related failure.

When changing gear, use human input only. After the gear is changed, you may accelerate again with the throttle or continue using the PAS.

Take off with the appropriate assist level & bike gear.

This product is splash proof and rain proof but NOT WATER PROOF. Do not submerge it underwater.

Disclaimer

If you require any more information or have any questions about the user manual disclaimer, please feel free to contact us via email at support@cycmotor.com or call +852 3690 8938.

All the information contained in this user's manual is published in good faith and for general informational purposes only. CYC Motor Ltd does not make any warranties about the completeness of this information and encourages further inquiries as stated above if needed. CYC Motor Ltd will not be held liable for any losses and/or damages in connection with the use of this product. The use of this product is at the user's own risk.

Notice: Please contact CYC Motor Ltd if you are unsure about the assembly instructions or for any further assistance as CYC Motor Ltd will be held liable for any losses and/or damages created by the assembly.



Description

This product is a high-powered electric bike (ebike) drive unit kit which includes a programmed control unit and peripherals. This product is designed to be installed as a conversion system to convert standard bicycles into electric bicycles.

Specifications

Rated Voltage	36 - 52V
Max. RPM at Crank	>300 RPM
Rated Power	1500W (CYC X6)
Max. Rated Torque at Crank	150 N.m. (CYC X6)
Overall Efficiency	>90%
Colour	Anodized Black
Weight of Motor & Controller	2.7kg
Total Weight with Crank set & BB	4.5kg
Bracket Materials	7075-T6
Crank Arm Length	165mm or 175mm
Q Factor	190mm
Control Method	FOC
Motor Sensor	Hall & Temp. Sensor
Chain ring	11/53 option with 32T 11/63 option with 38T
Compatibility	68mm, BB92, BB30/PF30 (compatible with adapter)



Parts List



PHOTON assembly



or

SW102 or DS103 Display



or

Thumb, Half-Twist or Full Throttle



Magnetic Bluetooth Speed Sensor



Bottom Bracket Spacers
(3, 5 & 7mm for BSA version;
2mm (2pcs) for BB92 version)



Magnetic Brake Sensors
(optional)



Controller Extension Wires
(optional)



Headlights
(optional)

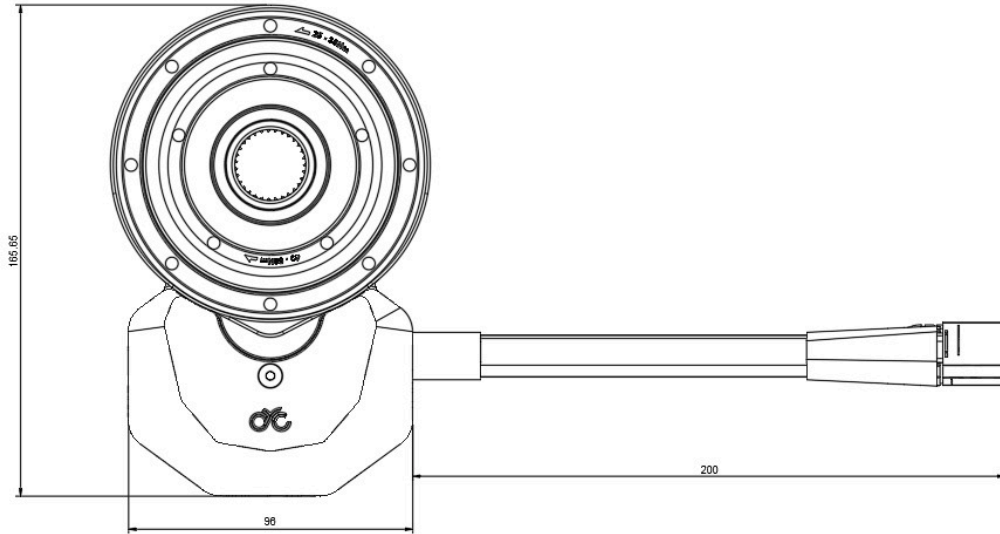

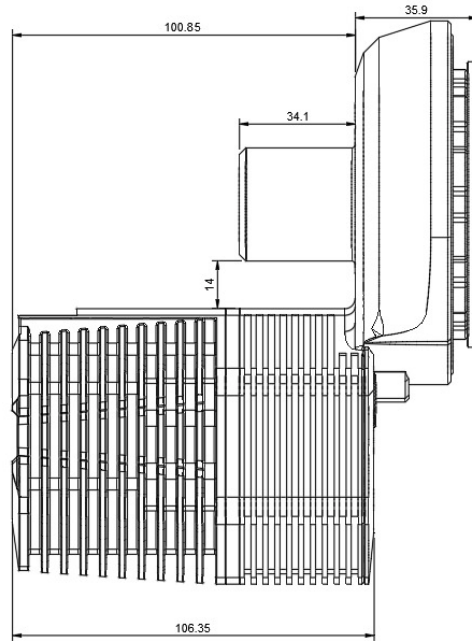

FCC Warning:

This equipment has been tested and found to comply with the limits for a Class B digital device, pursuant to part 15 of the FCC Rules. These limits are designed to provide reasonable protection against harmful interference in a residential installation. This equipment generates, uses and can radiate radio frequency energy and, if not installed and used in accordance with the instructions, may cause harmful interference to radio communications. However, there is no guarantee that interference will not occur in a particular installation. If this equipment does cause harmful interference to radio or television reception, which can be determined by turning the equipment off and on, the user is encouraged to try to correct the interference by one or more of the following measures:

- Reorient or relocate the receiving antenna.
- Increase the separation between the equipment and receiver.
- Connect the equipment into an outlet on a circuit different from that to which the receiver is connected.
- Consult the dealer or an experienced radio/TV technician for help.

Caution: Any changes or modifications to this device not explicitly approved by manufacturer could void your authority to operate this equipment.

This device complies with part 15 of the FCC Rules. Operation is subject to the following two conditions:

(1) This device may not cause harmful interference, and (2) this device must accept any interference received, including interference that may cause undesired operation.

This equipment complies with FCC radiation exposure limits set forth for an uncontrolled environment. This equipment should be installed and operated with minimum distance 20cm between the radiator and your body.