



TEST REPORT

FCC ID.	2A9WZV98PRO	
Test Report No.	TCT221229E017	
Date of issue	Feb. 24, 2023	
Testing laboratory	SHENZHEN TONGCE TESTING LAB	
Testing location/ address:	2101 & 2201, Zhenchang Factory Renshan Industrial Zone, Fuhai Subdistrict, Bao'an District, Shenzhen, Guangdong, 518103, People's Republic of China	
Applicant's name	Fuzhou Geek Yanxuan Technology Co., Ltd.	
Address	99 Qunzhong Dong Lu, Xingang Street, Taijiang District, Fuzhou City, Fujian Province, China.	
Manufacturer's name ...	Dongguan Nuobida Intelligent Technology Co., Ltd	
Address	21 Second Road, Yuantou New Village, Humen Town, Dongguan City, Guangdong Province, China.	
Standard(s)	FCC CFR Title 47 Part 15 Subpart C Section 15.247 FCC KDB 558074 D01 15.247 Meas Guidance v05r02 ANSI C63.10:2013	
Product Name	VGN V98Pro Mechanical Keyboard	
Trade Mark	VGN	
Model/Type reference	V98Pro, V98	
Rating(s)	Input: DC 5V Rechargeable Li-ion Battery DC 3.7V	
Date of receipt of test item	Dec. 29, 2022	
Date (s) of performance of test	Dec. 29, 2022 ~ Feb. 24, 2023	
Tested by (+signature) ...	Ronaldo LUO	
Check by (+signature)	Beryl ZHAO	
Approved by (+signature):	Tomsin	



General disclaimer:

This report shall not be reproduced except in full, without the written approval of SHENZHEN TONGCE TESTING LAB. This document may be altered or revised by SHENZHEN TONGCE TESTING LAB personnel only, and shall be noted in the revision section of the document. The test results in the report only apply to the tested sample.

Table of Contents

1. General Product Information	3
1.1. EUT description	3
1.2. Model(s) list.....	3
1.3. Operation Frequency	3
2. Test Result Summary	4
3. General Information.....	5
3.1. Test environment and mode.....	5
3.2. Description of Support Units.....	5
4. Facilities and Accreditations	6
4.1. Facilities	6
4.2. Location	6
4.3. Measurement Uncertainty.....	6
5. Test Results and Measurement Data	7
5.1. Antenna requirement	7
5.2. Conducted Emission.....	8
5.3. Conducted Output Power	12
5.4. Emission Bandwidth	13
5.5. Power Spectral Density.....	14
5.6. Conducted Band Edge and Spurious Emission Measurement	15
5.7. Radiated Spurious Emission Measurement.....	17
Appendix A: Test Result of Conducted Test	
Appendix B: Photographs of Test Setup	
Appendix C: Photographs of EUT	

1. General Product Information

1.1. EUT description

Product Name.....:	VGN V98Pro Mechanical Keyboard
Model/Type reference.....:	V98Pro
Sample Number.....:	TCT221229E016-0101
Bluetooth Version	V5.1 (This report is for BLE)
Operation Frequency	2402MHz~2480MHz
Channel Separation	2MHz
Data Rate.....:	LE 1M PHY
Number of Channel	40
Modulation Type.....:	GFSK
Antenna Type.....:	PCB Antenna
Antenna Gain.....:	0.338dBi
Rating(s).....:	Input: DC 5V Rechargeable Li-ion Battery DC 3.7V

Note: The antenna gain listed in this report is provided by applicant, and the test laboratory is not responsible for this parameter.

1.2. Model(s) list

No.	Model No.	Tested with
1	V98Pro	<input checked="" type="checkbox"/>
Other models	V98	<input type="checkbox"/>

Note: V98Pro is tested model, other models are derivative models. The models are identical in circuit and PCB layout, only different on the model names. So the test data of V98Pro can represent the remaining models.

1.3. Operation Frequency

Channel	Frequency	Channel	Frequency	Channel	Frequency	Channel	Frequency
0	2402MHz	10	2422MHz	20	2442MHz	30	2462MHz
1	2404MHz	11	2424MHz	21	2444MHz	31	2464MHz
...
8	2418MHz	18	2438MHz	28	2458MHz	38	2478MHz
9	2420MHz	19	2440MHz	29	2460MHz	39	2480MHz

Remark: Channel 0, 19 & 39 have been tested.

2. Test Result Summary

Requirement	CFR 47 Section	Result
Antenna requirement	§15.203/§15.247 (c)	PASS
AC Power Line Conducted Emission	§15.207	PASS
Conducted Peak Output Power	§15.247 (b)(3)	PASS
6dB Emission Bandwidth	§15.247 (a)(2)	PASS
Power Spectral Density	§15.247 (e)	PASS
Band Edge	§15.247(d)	PASS
Spurious Emission	§15.205/§15.209	PASS

Note:

1. PASS: Test item meets the requirement.
2. Fail: Test item does not meet the requirement.
3. N/A: Test case does not apply to the test object.
4. The test result judgment is decided by the limit of test standard.
5. After pre-testing the two earphones, the two earphones are left and right ears respectively; we found that the left earphone is the worst case, so the results are recorded in this report.

3. General Information

3.1. Test environment and mode

Operating Environment:		
Condition	Conducted Emission	Radiated Emission
Temperature:	25.0 °C	25.0 °C
Humidity:	55 % RH	55 % RH
Atmospheric Pressure:	1010 mbar	1010 mbar
Test Software:		
Software Information:	Key combination fixed frequency	
Power Level:	Default	
Test Mode:		
Engineering mode:	Keep the EUT in continuous transmitting by select channel and modulations with Fully-charged battery.	
The sample was placed 0.8m & 1.5m for the measurement below & above 1GHz above the ground plane of 3m chamber. Measurements in both horizontal and vertical polarities were performed. During the test, each emission was maximized by: having the EUT continuously working, investigated all operating modes, rotated about all 3 axis (X, Y & Z) and considered typical configuration to obtain worst position, manipulating interconnecting cables, rotating the turntable, varying antenna height from 1m to 4m in both horizontal and vertical polarizations. The emissions worst-case(Z axis) are shown in Test Results of the following pages.		

3.2. Description of Support Units

The EUT has been tested as an independent unit together with other necessary accessories or support units. The following support units or accessories were used to form a representative test configuration during the tests.

Equipment	Model No.	Serial No.	FCC ID	Trade Name
Adapter	JD-050200	2012010907576735	/	JD

Note:

1. All the equipment/cables were placed in the worst-case configuration to maximize the emission during the test.
2. Grounding was established in accordance with the manufacturer's requirements and conditions for the intended use.
3. For conducted measurements (Output Power, 6dB Emission Bandwidth, Power Spectral Density, Spurious Emissions), the antenna of EUT is connected to the test equipment via temporary antenna connector, the antenna connector is soldered on the antenna port of EUT, and the temporary antenna connector is listed in the Test Instruments.

4. Facilities and Accreditations

4.1. Facilities

The test facility is recognized, certified, or accredited by the following organizations:

- FCC - Registration No.: 645098

SHENZHEN TONGCE TESTING LAB

Designation Number: CN1205

The testing lab has been registered and fully described in a report with the (FCC) Federal Communications Commission. The acceptance letter from the FCC is maintained in our files.

- IC - Registration No.: 10668A-1

SHENZHEN TONGCE TESTING LAB

CAB identifier: CN0031

The testing lab has been registered by Certification and Engineering Bureau of Industry Canada for radio equipment testing.

4.2. Location

SHENZHEN TONGCE TESTING LAB

Address: 2101 & 2201, Zhenchang Factory Renshan Industrial Zone, Fuhai Subdistrict, Bao'an District, Shenzhen, Guangdong, 518103, People's Republic of China

TEL: +86-755-27673339

4.3. Measurement Uncertainty

The reported uncertainty of measurement $y \pm U$, where expanded uncertainty U is based on a standard uncertainty multiplied by a coverage factor of $k=2$, providing a level of confidence of approximately 95 %.

No.	Item	MU
1	Conducted Emission	± 3.10 dB
2	RF power, conducted	± 0.12 dB
3	Spurious emissions, conducted	± 0.11 dB
4	All emissions, radiated(<1 GHz)	± 4.56 dB
5	All emissions, radiated(1 GHz - 18 GHz)	± 4.22 dB
6	All emissions, radiated(18 GHz- 40 GHz)	± 4.36 dB

5. Test Results and Measurement Data

5.1. Antenna requirement

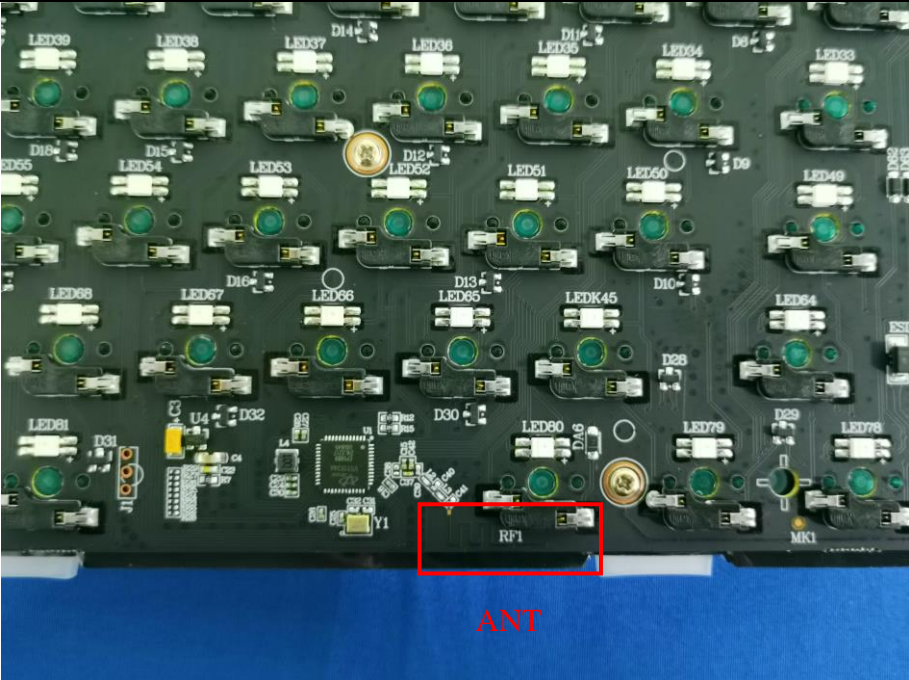
Standard requirement:	FCC Part15 C Section 15.203 /247(c)
<p>15.203 requirement: An intentional radiator shall be designed to ensure that no antenna other than that furnished by the responsible party shall be used with the device. The use of a permanently attached antenna or of an antenna that uses a unique coupling to the intentional radiator, the manufacturer may design the unit so that a broken antenna can be replaced by the user, but the use of a standard antenna jack or electrical connector is prohibited.</p> <p>15.247(c) (1)(i) requirement: (i) Systems operating in the 2400-2483.5 MHz band that is used exclusively for fixed. Point-to-point operations may employ transmitting antennas with directional gain greater than 6dBi provided the maximum conducted output power of the intentional radiator is reduced by 1 dB for every 3 dB that the directional gain of the antenna exceeds 6dBi.</p>	
E.U.T Antenna:	PCB Antenna
<p>The Bluetooth antenna is PCB antenna which permanently attached, and the best case gain of the antenna is 0.338 dBi.</p>	
	

5.2. Conducted Emission

5.2.1. Test Specification

Test Requirement:	FCC Part15 C Section 15.207														
Test Method:	ANSI C63.10:2013														
Frequency Range:	150 kHz to 30 MHz														
Receiver setup:	RBW=9 kHz, VBW=30 kHz, Sweep time=auto														
Limits:	<table border="1"> <thead> <tr> <th rowspan="2">Frequency range (MHz)</th> <th colspan="2">Limit (dBuV)</th> </tr> <tr> <th>Quasi-peak</th> <th>Average</th> </tr> </thead> <tbody> <tr> <td>0.15-0.5</td> <td>66 to 56*</td> <td>56 to 46*</td> </tr> <tr> <td>0.5-5</td> <td>56</td> <td>46</td> </tr> <tr> <td>5-30</td> <td>60</td> <td>50</td> </tr> </tbody> </table>	Frequency range (MHz)	Limit (dBuV)		Quasi-peak	Average	0.15-0.5	66 to 56*	56 to 46*	0.5-5	56	46	5-30	60	50
Frequency range (MHz)	Limit (dBuV)														
	Quasi-peak	Average													
0.15-0.5	66 to 56*	56 to 46*													
0.5-5	56	46													
5-30	60	50													
Test Setup:	<p>Remark: E.U.T: Equipment Under Test LISN: Line Impedance Stabilization Network Test table height=0.8m</p>														
Test Mode:	Charging + Transmitting Mode														
Test Procedure:	<ol style="list-style-type: none"> 1. The E.U.T is connected to an adapter through a line impedance stabilization network (L.I.S.N.). This provides a 50ohm/50uH coupling impedance for the measuring equipment. 2. The peripheral devices are also connected to the main power through a LISN that provides a 50ohm/50uH coupling impedance with 50ohm termination. (Please refer to the block diagram of the test setup and photographs). 3. Both sides of A.C. line are checked for maximum conducted interference. In order to find the maximum emission, the relative positions of equipment and all of the interface cables must be changed according to ANSI C63.10: 2013 on conducted measurement. 														
Test Result:	PASS														

5.2.2. Test Instruments

Conducted Emission Shielding Room Test Site (843)				
Equipment	Manufacturer	Model	Serial Number	Calibration Due
EMI Test Receiver	R&S	ESCI3	100898	Jul. 03, 2023
Line Impedance Stabilisation Newtork(LISN)	Schwarzbeck	NSLK 8126	8126453	Feb. 24, 2023
Line-5	TCT	CE-05	/	Jul. 03, 2024
EMI Test Software	Shurple Technology	EZ-EMC	/	/

5.2.3. Test data

Please refer to following diagram for individual
Conducted Emission on Line Terminal of the power line (150 kHz to 30MHz)

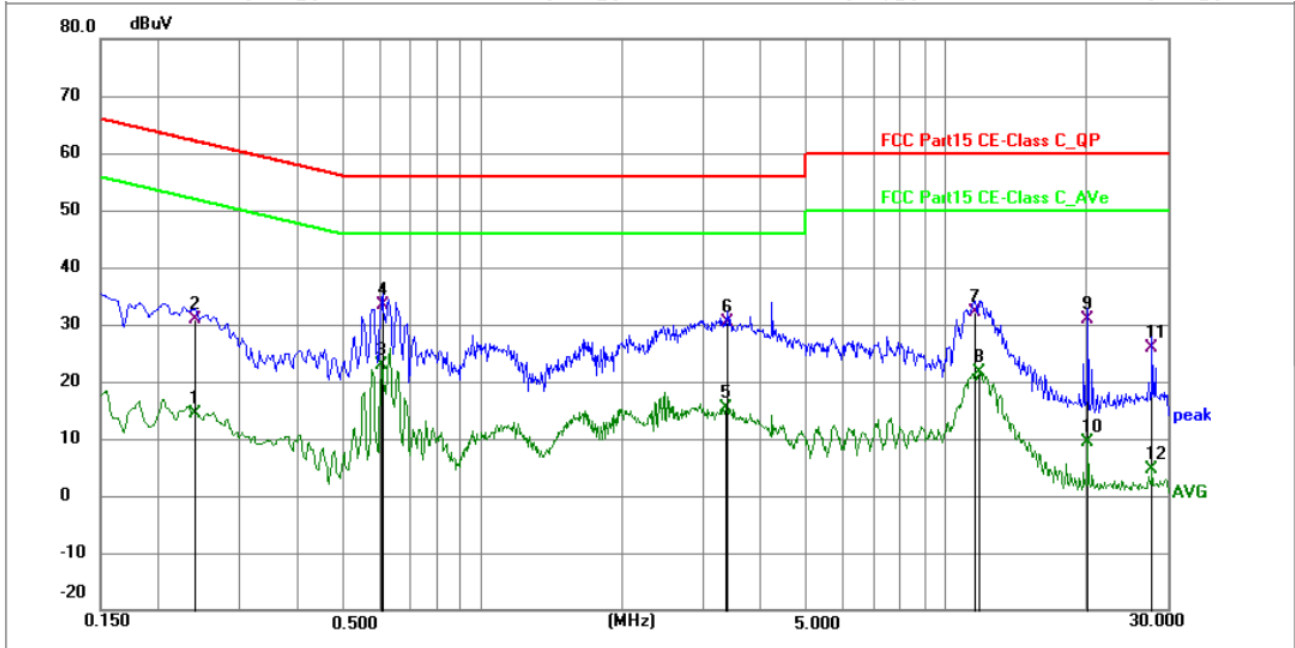

No.	Frequency (MHz)	Reading (dBuV)	Factor (dB)	Level (dBuV)	Limit (dBuV)	Margin (dB)	Detector	P/F	Remark
1	0.2391	4.25	10.20	14.45	52.13	-37.68	AVG	P	
2	0.2400	20.64	10.20	30.84	62.10	-31.26	QP	P	
3	0.6045	12.68	10.25	22.93	46.00	-23.07	AVG	P	
4 *	0.6090	23.23	10.25	33.48	56.00	-22.52	QP	P	
5	3.3540	4.99	10.28	15.27	46.00	-30.73	AVG	P	
6	3.3720	20.00	10.28	30.28	56.00	-25.72	QP	P	
7	11.5530	21.98	10.24	32.22	60.00	-27.78	QP	P	
8	11.7870	11.31	10.22	21.53	50.00	-28.47	AVG	P	
9	20.2110	21.13	9.86	30.99	60.00	-29.01	QP	P	
10	20.2110	-0.46	9.86	9.40	50.00	-40.60	AVG	P	
11	27.7845	16.01	9.78	25.79	60.00	-34.21	QP	P	
12	27.7845	-5.09	9.78	4.69	50.00	-45.31	AVG	P	

Note:

Freq. = Emission frequency in MHz

Reading level (dBuV) = Receiver reading

Corr. Factor (dB) = LISN factor + Cable loss

Measurement (dBuV) = Reading level (dBuV) + Corr. Factor (dB)

Limit (dBuV) = Limit stated in standard

Margin (dB) = Measurement (dBuV) – Limits (dBuV)

Q.P. =Quasi-Peak

AVG =average

* is meaning the worst frequency has been tested in the frequency range 150 kHz to 30MHz

Conducted Emission on Neutral Terminal of the power line (150 kHz to 30MHz)

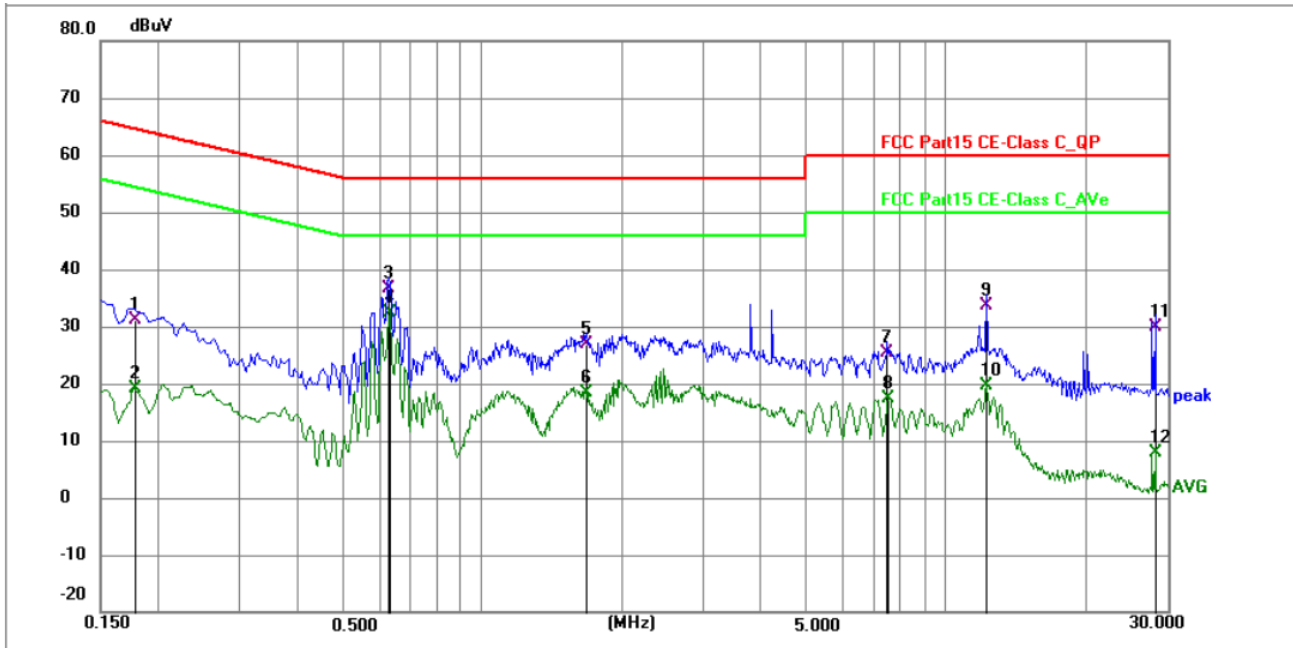

No.	Frequency (MHz)	Reading (dBuV)	Factor (dB)	Level (dBuV)	Limit (dBuV)	Margin (dB)	Detector	P/F	Remark
1	0.1770	20.96	10.21	31.17	64.63	-33.46	QP	P	
2	0.1770	8.96	10.21	19.17	54.63	-35.46	AVG	P	
3	0.6270	26.34	10.24	36.58	56.00	-19.42	QP	P	
4 *	0.6315	22.21	10.24	32.45	46.00	-13.55	AVG	P	
5	1.6755	16.55	10.24	26.79	56.00	-29.21	QP	P	
6	1.6755	8.11	10.24	18.35	46.00	-27.65	AVG	P	
7	7.4760	15.11	10.30	25.41	60.00	-34.59	QP	P	
8	7.5255	7.03	10.29	17.32	50.00	-32.68	AVG	P	
9	12.2100	23.43	10.18	33.61	60.00	-26.39	QP	P	
10	12.2100	9.33	10.18	19.51	50.00	-30.49	AVG	P	
11	28.2075	20.21	9.79	30.00	60.00	-30.00	QP	P	
12	28.2075	-1.85	9.79	7.94	50.00	-42.06	AVG	P	

Note1:

Freq. = Emission frequency in MHz

Reading level (dBuV) = Receiver reading

Corr. Factor (dB) = LISN factor + Cable loss

Measurement (dBuV) = Reading level (dBuV) + Corr. Factor (dB)

Limit (dBuV) = Limit stated in standard

Margin (dB) = Measurement (dBuV) – Limits (dBuV)

Q.P. =Quasi-Peak

AVG =average

** is meaning the worst frequency has been tested in the frequency range 150 kHz to 30MHz.*

5.3. Conducted Output Power

5.3.1. Test Specification

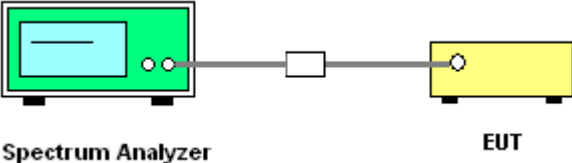
Test Requirement:	FCC Part15 C Section 15.247 (b)(3)
Test Method:	KDB 558074 D01 v05r02
Limit:	30dBm
Test Setup:	 <p>The diagram illustrates the test setup. On the left is a green Spectrum Analyzer. A cable connects it to a white combiner box. Another cable connects the combiner box to a yellow EUT (Equipment Under Test). Labels 'Spectrum Analyzer' and 'EUT' are placed below their respective components.</p>
Test Mode:	Refer to item 3.1
Test Procedure:	<p>Set spectrum analyzer as following:</p> <ol style="list-style-type: none"> a) Set the RBW \geq DTS bandwidth. b) Set VBW $\geq 3 \times$ RBW. c) Set span $\geq 3 \times$ RBW d) Sweep time = auto couple. e) Detector = peak. f) Trace mode = max hold. g) Allow trace to fully stabilize. h) Use peak marker function to determine the peak amplitude level.
Test Result:	PASS

5.3.2. Test Instruments

Name	Manufacturer	Model No.	Serial Number	Calibration Due
Spectrum Analyzer	R&S	FSU	200054	Jul. 04, 2023
Combiner Box	Ascentest	AT890-RFB	/	/

5.4. Emission Bandwidth

5.4.1. Test Specification

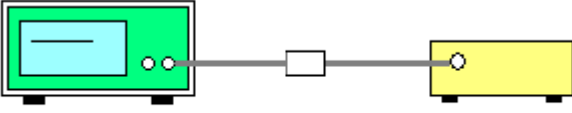
Test Requirement:	FCC Part15 C Section 15.247 (a)(2)
Test Method:	KDB 558074 D01 v05r02
Limit:	>500kHz
Test Setup:	 <p style="text-align: center;">Spectrum Analyzer EUT</p>
Test Mode:	Refer to item 3.1
Test Procedure:	<ol style="list-style-type: none"> 1. Set to the maximum power setting and enable the EUT transmit continuously. 2. Make the measurement with the spectrum analyzer's resolution bandwidth (RBW) = 100 kHz. Set the Video bandwidth (VBW) = 300 kHz. In order to make an accurate measurement. The 6dB bandwidth must be greater than 500 kHz. 3. Measure and record the results in the test report.
Test Result:	PASS

5.4.2. Test Instruments

Name	Manufacturer	Model No.	Serial Number	Calibration Due
Spectrum Analyzer	R&S	FSU	200054	Jul. 04, 2023
Combiner Box	Ascentest	AT890-RFB	/	/

5.5. Power Spectral Density

5.5.1. Test Specification

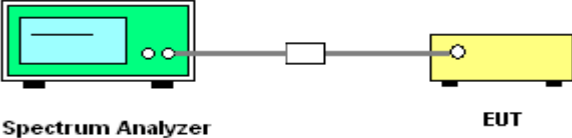
Test Requirement:	FCC Part15 C Section 15.247 (e)
Test Method:	KDB 558074 D01 v05r02
Limit:	The peak power spectral density shall not be greater than 8dBm in any 3kHz band at any time interval of continuous transmission.
Test Setup:	 <p>The diagram shows a green Spectrum Analyzer connected to a yellow EUT (Equipment Under Test) via a white attenuator. The Spectrum Analyzer is on the left, and the EUT is on the right. A cable connects them through the attenuator.</p>
Test Mode:	Refer to item 3.1
Test Procedure:	<ol style="list-style-type: none"> 1. The RF output of EUT was connected to the spectrum analyzer by RF cable and attenuator. The path loss was compensated to the results for each measurement. 2. Set to the maximum power setting and enable the EUT transmit continuously. 3. Make the measurement with the spectrum analyzer's resolution bandwidth (RBW): $3 \text{ kHz} \leq \text{RBW} \leq 100 \text{ kHz}$. Video bandwidth $\text{VBW} \geq 3 \times \text{RBW}$. In order to make an accurate measurement, set the span to 1.5 times DTS Channel Bandwidth. (6dB BW) 4. Detector = peak, Sweep time = auto couple, Trace mode = max hold, Allow trace to fully stabilize. Use the peak marker function to determine the maximum power level. 5. Measure and record the results in the test report.
Test Result:	PASS

5.5.2. Test Instruments

Name	Manufacturer	Model No.	Serial Number	Calibration Due
Spectrum Analyzer	R&S	FSU	200054	Jul. 04, 2023
Combiner Box	Ascentest	AT890-RFB	/	/

5.6. Conducted Band Edge and Spurious Emission Measurement

5.6.1. Test Specification

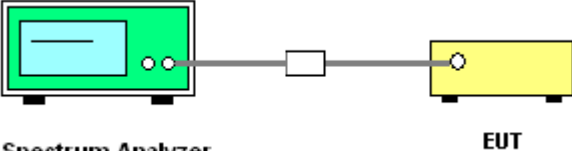
Test Requirement:	FCC Part15 C Section 15.247 (d)
Test Method:	KDB 558074 D01 v05r02
Limit:	In any 100 kHz bandwidth outside of the authorized frequency band, the emissions which fall in the non-restricted bands shall be attenuated at least 20 dB / 30dB relative to the maximum PSD level in 100 kHz by RF conducted measurement and radiated emissions which fall in the restricted bands, as defined in Section 15.205(a), must also comply with the radiated emission limits specified in Section 15.209(a).
Test Setup:	 <p style="text-align: center;">Spectrum Analyzer EUT</p>
Test Mode:	Refer to item 3.1
Test Procedure:	<ol style="list-style-type: none"> 1. The RF output of EUT was connected to the spectrum analyzer by RF cable and attenuator. The path loss was compensated to the results for each measurement. 2. Set to the maximum power setting and enable the EUT transmit continuously. 3. Set RBW = 100 kHz, VBW=300 kHz, Peak Detector. Unwanted Emissions measured in any 100 kHz bandwidth outside of the authorized frequency band shall be attenuated by at least 20 dB relative to the maximum in-band peak PSD level in 100 kHz when maximum peak conducted output power procedure is used. If the transmitter complies with the conducted power limits based on the use of RMS averaging over a time interval, the attenuation required under this paragraph shall be 30 dB instead of 20 dB per 15.247(d). 4. Measure and record the results in the test report. 5. The RF fundamental frequency should be excluded against the limit line in the operating frequency band.
Test Result:	PASS

5.6.2. Test Instruments

Name	Manufacturer	Model No.	Serial Number	Calibration Due
Spectrum Analyzer	R&S	FSU	200054	Jul. 04, 2023
Combiner Box	Ascentest	AT890-RFB	/	/

5.7. Radiated Spurious Emission Measurement

5.7.1. Test Specification

Test Requirement:	FCC Part15 C Section 15.209					
Test Method:	ANSI C63.10: 2013					
Frequency Range:	9 kHz to 25 GHz					
Measurement Distance:	3 m					
Antenna Polarization:	Horizontal & Vertical					
Operation mode:	Refer to item 3.1					
Receiver Setup:	Frequency	Detector	RBW	VBW	Remark	
	9kHz- 150kHz	Quasi-peak	200Hz	1kHz	Quasi-peak Value	
	150kHz- 30MHz	Quasi-peak	9kHz	30kHz	Quasi-peak Value	
	30MHz-1GHz	Quasi-peak	120KHz	300KHz	Quasi-peak Value	
	Above 1GHz	Peak	1MHz	3MHz	Peak Value	
		Peak	1MHz	10Hz	Average Value	
Limit:	Frequency	Field Strength (microvolts/meter)	Measurement Distance (meters)			
	0.009-0.490	2400/F(KHz)	300			
	0.490-1.705	24000/F(KHz)	30			
	1.705-30	30	30			
	30-88	100	3			
	88-216	150	3			
	216-960	200	3			
	Above 960	500	3			
	Frequency	Field Strength (microvolts/meter)	Measurement Distance (meters)	Detector		
	Above 1GHz	500	3	Average		
	5000	3	Peak			
Test setup:	For radiated emissions below 30MHz					
	<p>Distance = 3m</p> <p>0.8m</p> <p>Turn table</p> <p>1m</p> <p>Ground Plane</p> <p>Computer</p> <p>Pre-Amplifier</p> <p>Receiver</p>					
	30MHz to 1GHz					

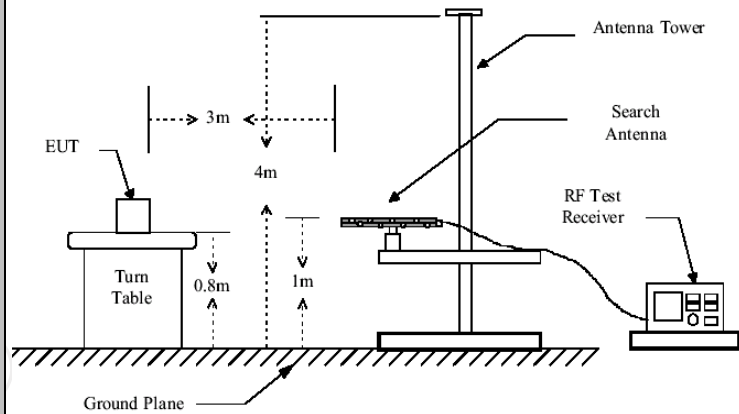

Above 1GHz

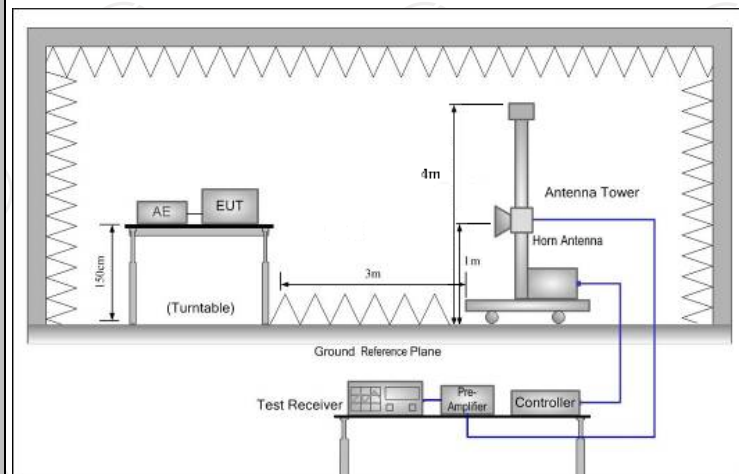

Test Procedure:

1. For the radiated emission test below 1GHz:
The EUT was placed on a turntable with 0.8 meter above ground. The EUT was set 3 meters from the interference receiving antenna, which was mounted on the top of a variable height antenna tower. The EUT was arranged to its worst case and then tune the antenna tower (from 1 m to 4 m) and turntable (from 0 degree to 360 degrees) to find the maximum reading. A pre-amp and a high PASS filter are used for the test in order to get better signal level.
- For the radiated emission test above 1GHz:
Place the measurement antenna on a turntable with 1.5 meter above ground, which is away from each area of the EUT determined to be a source of emissions at the specified measurement distance, while keeping the measurement antenna aimed at the source of emissions at each frequency of significant emissions, with polarization oriented for maximum response. The measurement antenna may have to be higher or lower than the EUT, depending on the radiation pattern of the emission and staying aimed at the emission source for receiving the maximum signal. The final

	<p>measurement antenna elevation shall be that which maximizes the emissions. The measurement antenna elevation for maximum emissions shall be restricted to a range of heights of from 1 m to 4 m above the ground or reference ground plane.</p> <p>2. Corrected Reading: Antenna Factor + Cable Loss + Read Level - Preamp Factor = Level</p> <p>3. For measurement below 1GHz, If the emission level of the EUT measured by the peak detector is 3 dB lower than the applicable limit, the peak emission level will be reported. Otherwise, the emission measurement will be repeated using the quasi-peak detector and reported.</p> <p>4. Use the following spectrum analyzer settings:</p> <p>(1) Span shall wide enough to fully capture the emission being measured;</p> <p>(2) Set RBW=120 kHz for $f < 1$ GHz; VBW \geq RBW; Sweep = auto; Detector function = peak; Trace = max hold;</p> <p>(3) Set RBW = 1 MHz, VBW= 3MHz for $f > 1$ GHz for peak measurement.</p> <p>For average measurement: VBW = 10 Hz, when duty cycle is no less than 98 percent. VBW $\geq 1/T$, when duty cycle is less than 98 percent where T is the minimum transmission duration over which the transmitter is on and is transmitting at its maximum power control level for the tested mode of operation.</p>
Test mode:	Refer to section 4.1 for details
Test results:	PASS

5.7.2. Test Instruments

Radiated Emission Test Site (966)				
Name of Equipment	Manufacturer	Model	Serial Number	Calibration Due
EMI Test Receiver	R&S	ESIB7	100197	Jul. 03, 2023
Spectrum Analyzer	R&S	FSQ40	200061	Jul. 03, 2023
Pre-amplifier	SKET	LNPA_0118G-45	SK2021012102	Feb. 24, 2023
Pre-amplifier	SKET	LNPA_1840G-50	SK202109203500	Feb. 24, 2023
Pre-amplifier	HP	8447D	2727A05017	Jul. 03, 2023
Loop antenna	Schwarzbeck	FMZB1519B	00191	Jun. 11, 2024
Broadband Antenna	Schwarzbeck	VULB9163	340	Jul. 05, 2024
Horn Antenna	Schwarzbeck	BBHA 9120D	631	Jul. 05, 2024
Horn Antenna	Schwarzbeck	BBHA 9170	00956	Apr. 10, 2023
Antenna Mast	Keleto	RE-AM	/	/
Coaxial cable	SKET	RC-18G-N-M	/	Feb. 24, 2024
Coaxial cable	SKET	RC_40G-K-M	/	Feb. 24, 2024
EMI Test Software	Shurple Technology	EZ-EMC	/	/

5.7.3. Test Data

Please refer to following diagram for individual
Below 1GHz

Horizontal:

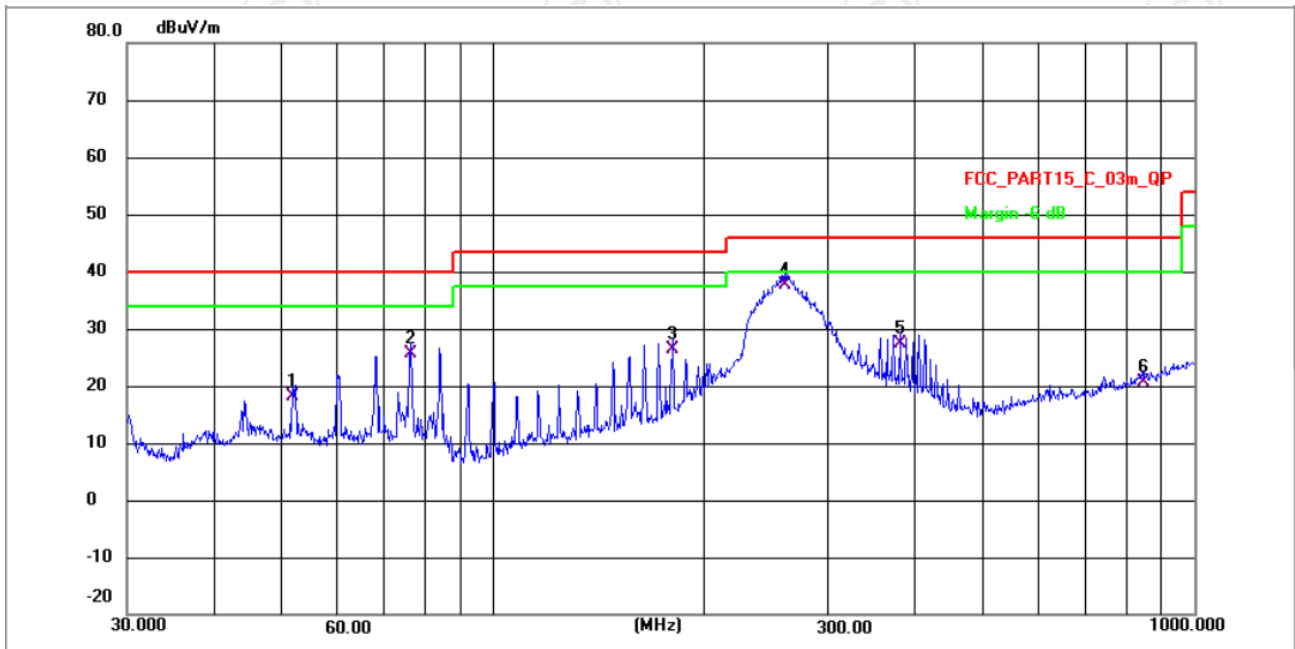

No.	Frequency (MHz)	Reading (dBuV)	Factor (dB/m)	Level (dBuV/m)	Limit (dBuV/m)	Margin (dB)	Detector	P/F
1	51.6616	31.73	-13.50	18.23	40.00	-21.77	QP	P
2	76.2442	53.42	-27.90	25.52	40.00	-14.48	QP	P
3	180.0165	53.53	-27.14	26.39	43.50	-17.11	QP	P
4 *	260.1444	64.22	-26.64	37.58	46.00	-8.42	QP	P
5	379.9141	53.30	-25.91	27.39	46.00	-18.61	QP	P
6	848.0563	45.35	-24.84	20.51	46.00	-25.49	QP	P

Vertical:

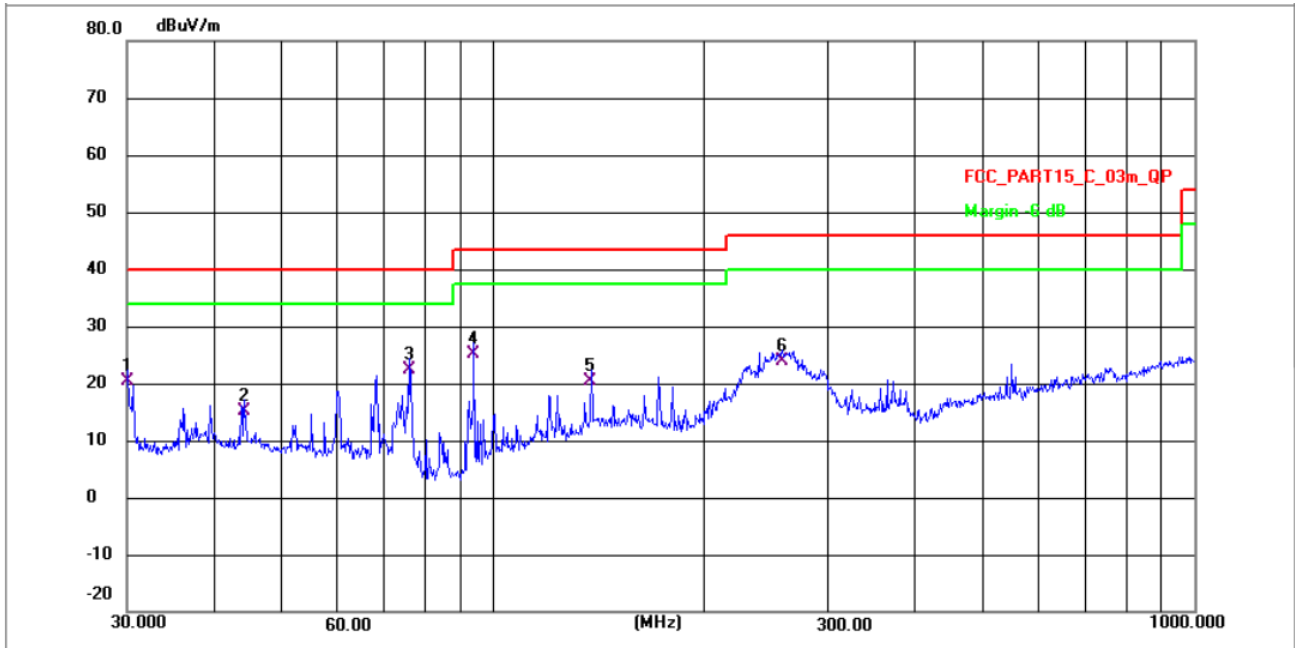

No.	Frequency (MHz)	Reading (dBuV)	Factor (dB/m)	Level (dBuV/m)	Limit (dBuV/m)	Margin (dB)	Detector	P/F
1	30.1054	38.50	-18.21	20.29	40.00	-19.71	QP	P
2	44.1202	30.30	-15.29	15.01	40.00	-24.99	QP	P
3 *	75.7114	50.32	-27.90	22.42	40.00	-17.58	QP	P
4	93.7685	52.93	-27.80	25.13	43.50	-18.37	QP	P
5	137.9028	47.69	-27.32	20.37	43.50	-23.13	QP	P
6	258.3264	50.55	-26.65	23.90	46.00	-22.10	QP	P

Note: 1. The low frequency, which started from 9KHz~30MHz, was pre-scanned and the result which was 20dB lower than the limit line per 15.31(o) was not reported

2. Measurements were conducted in all three channels (high, middle, low), and the worst case Mode (Lowest channel) was submitted only.

3. Freq. = Emission frequency in MHz

Measurement (dBuV/m) = Reading level (dBuV) + Corr. Factor (dB)

Correction Factor = Antenna Factor + Cable loss – Pre-amplifier

Limit (dBuV/m) = Limit stated in standard

Margin (dB) = Measurement (dBuV/m) – Limits (dBuV/m)

Any value more than 10dB below limit have not been specifically reported

* is meaning the worst frequency has been tested in the test frequency range

Test Result of Radiated Spurious at Band edges

Lowest channel 2402:

1Mbps

Horizontal:

No.	Frequency (MHz)	Reading (dBuV)	Factor (dB/m)	Level (dBuV/m)	Limit (dBuV/m)	Margin (dB)	Detector	P/F
1	2310.000	41.97	-5.05	36.92	74.00	-37.08	peak	P
2	2390.000	42.82	-4.97	37.85	74.00	-36.15	peak	P
3 *	2400.000	56.11	-4.96	51.15	74.00	-22.85	peak	P

Vertical:

No.	Frequency (MHz)	Reading (dBuV)	Factor (dB/m)	Level (dBuV/m)	Limit (dBuV/m)	Margin (dB)	Detector	P/F
1	2310.000	45.37	-6.45	38.92	74.00	-35.08	peak	P
2	2390.000	46.22	-6.37	39.85	74.00	-34.15	peak	P
3 *	2400.000	58.51	-6.36	52.15	74.00	-21.85	peak	P

Highest channel 2480:

1Mbps

Horizontal:

No.	Frequency (MHz)	Reading (dBuV)	Factor (dB/m)	Level (dBuV/m)	Limit (dBuV/m)	Margin (dB)	Detector	P/F
1 *	2483.500	50.19	-4.89	45.30	74.00	-28.70	peak	P
2	2500.000	43.29	-4.87	38.42	74.00	-35.58	peak	P

Vertical:

No.	Frequency (MHz)	Reading (dBuV)	Factor (dB/m)	Level (dBuV/m)	Limit (dBuV/m)	Margin (dB)	Detector	P/F
1 *	2483.500	49.59	-6.29	43.30	74.00	-30.70	peak	P
2	2500.000	43.19	-6.27	36.92	74.00	-37.08	peak	P

Above 1GHz

Low channel: 2402 MHz

Horizontal:

No.	Frequency (MHz)	Reading (dBuV)	Factor (dB/m)	Level (dBuV/m)	Limit (dBuV/m)	Margin (dB)	Detector	P/F
1	2599.367	68.68	-30.83	37.85	74.00	-36.15	peak	P
2	3546.577	63.96	-29.96	34.00	74.00	-40.00	peak	P
3	5507.917	67.36	-27.61	39.75	74.00	-34.25	peak	P
4	8358.401	68.47	-25.89	42.58	74.00	-31.42	peak	P
5 *	12009.761	73.32	-23.04	50.28	74.00	-23.72	peak	P
6	16174.372	66.69	-21.14	45.55	74.00	-28.45	peak	P

Vertical:

No.	Frequency (MHz)	Reading (dBuV)	Factor (dB/m)	Level (dBuV/m)	Limit (dBuV/m)	Margin (dB)	Detector	P/F
1	2893.598	71.36	-30.14	41.22	74.00	-32.78	peak	P
2	3445.535	72.58	-29.90	42.68	74.00	-31.32	peak	P
3	5310.934	68.39	-27.92	40.47	74.00	-33.53	peak	P
4	7281.933	70.25	-26.01	44.24	74.00	-29.76	peak	P
5	9555.255	72.41	-24.49	47.92	74.00	-26.08	peak	P
6 *	12750.244	71.14	-22.39	48.75	74.00	-25.25	peak	P

Middle channel: 2440 MHz

Horizontal:

No.	Frequency (MHz)	Reading (dBuV)	Factor (dB/m)	Level (dBuV/m)	Limit (dBuV/m)	Margin (dB)	Detector	P/F
1	3256.708	69.67	-29.90	39.77	74.00	-34.23	peak	P
2	4393.646	66.42	-30.27	36.15	74.00	-37.85	peak	P
3	6741.102	67.26	-25.88	41.38	74.00	-32.62	peak	P
4	8797.140	68.43	-25.53	42.90	74.00	-31.10	peak	P
5	10869.948	70.53	-24.67	45.86	74.00	-28.14	peak	P
6 *	13961.563	71.93	-21.69	50.24	74.00	-23.76	peak	P

Vertical:

No.	Frequency (MHz)	Reading (dBuV)	Factor (dB/m)	Level (dBuV/m)	Limit (dBuV/m)	Margin (dB)	Detector	P/F
1	3524.096	70.16	-29.93	40.23	74.00	-33.77	peak	P
2	4518.572	73.22	-30.13	43.09	74.00	-30.91	peak	P
3	5895.033	69.20	-26.87	42.33	74.00	-31.67	peak	P
4	9716.791	72.15	-24.53	47.62	74.00	-26.38	peak	P
5 *	13242.274	72.00	-21.50	50.50	74.00	-23.50	peak	P
6	16745.214	67.39	-19.74	47.65	74.00	-26.35	peak	P

High channel: 2480 MHz
Horizontal:

No.	Frequency (MHz)	Reading (dBuV)	Factor (dB/m)	Level (dBuV/m)	Limit (dBuV/m)	Margin (dB)	Detector	P/F
1	3105.935	70.82	-29.89	40.93	74.00	-33.07	peak	P
2	4612.258	72.70	-29.79	42.91	74.00	-31.09	peak	P
3	5588.094	73.00	-27.45	45.55	74.00	-28.45	peak	P
4 *	7746.571	75.76	-26.21	49.55	74.00	-24.45	peak	P
5	10548.061	74.15	-25.34	48.81	74.00	-25.19	peak	P
6	15213.027	69.30	-21.43	47.87	74.00	-26.13	peak	P

Vertical:

No.	Frequency (MHz)	Reading (dBuV)	Factor (dB/m)	Level (dBuV/m)	Limit (dBuV/m)	Margin (dB)	Detector	P/F
1	3090.711	74.79	-29.89	44.90	74.00	-29.10	peak	P
2	4484.742	73.17	-30.20	42.97	74.00	-31.03	peak	P
3	6543.372	65.44	-26.04	39.40	74.00	-34.60	peak	P
4	9638.470	69.89	-24.51	45.38	74.00	-28.62	peak	P
5 *	12691.415	69.54	-22.49	47.05	74.00	-26.95	peak	P
6	16409.819	66.50	-20.80	45.70	74.00	-28.30	peak	P

Note:

1. $Emission\ Level = Peak\ Reading + Correction\ Factor$; $Correction\ Factor = Antenna\ Factor + Cable\ loss - Pre-amplifier$
2. $Margin\ (dB) = Emission\ Level\ (Peak)\ (dB\mu V/m) - Average\ limit\ (dB\mu V/m)$
3. The emission levels of other frequencies are very lower than the limit and not show in test report.
4. Measurements were conducted from 1 GHz to the 10th harmonic of highest fundamental frequency.
5. Data of measurement shown "---" in the above table mean that the reading of emissions is attenuated more than 20 dB below the limits or the field strength is too small to be measured.
6. All the restriction bands are compliance with the limit of 15.209.

Appendix A: Test Result of Conducted Test

Maximum Conducted Output Power

Mode	TX Type	Frequency (MHz)	Maximum Peak Conducted Output Power (dBm)		Verdict
			ANT1	Limit	
1M	SISO	2402	-0.28	<=30	Pass
		2440	-0.42	<=30	Pass
		2480	-0.56	<=30	Pass

Note1: Antenna Gain: Ant1: 0.34dBi;

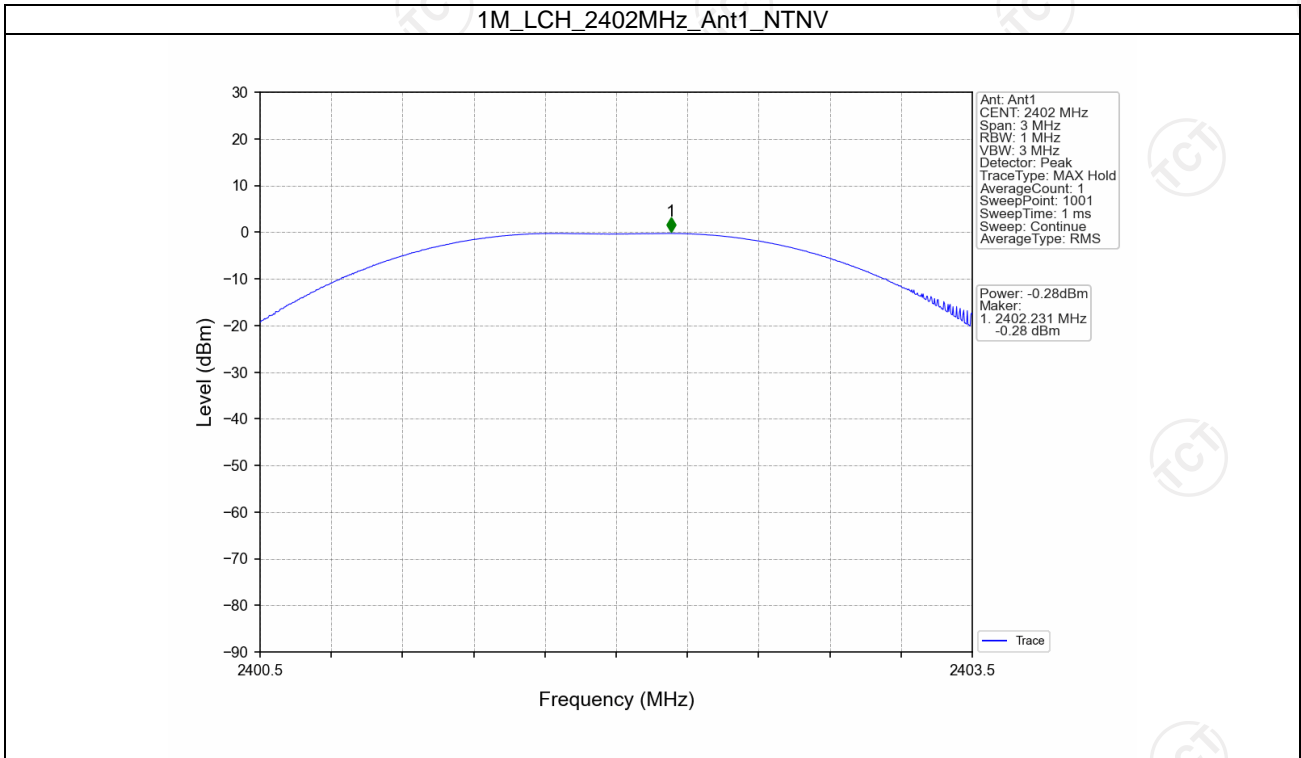

1M_MCH_2440MHz_Ant1_NTNV

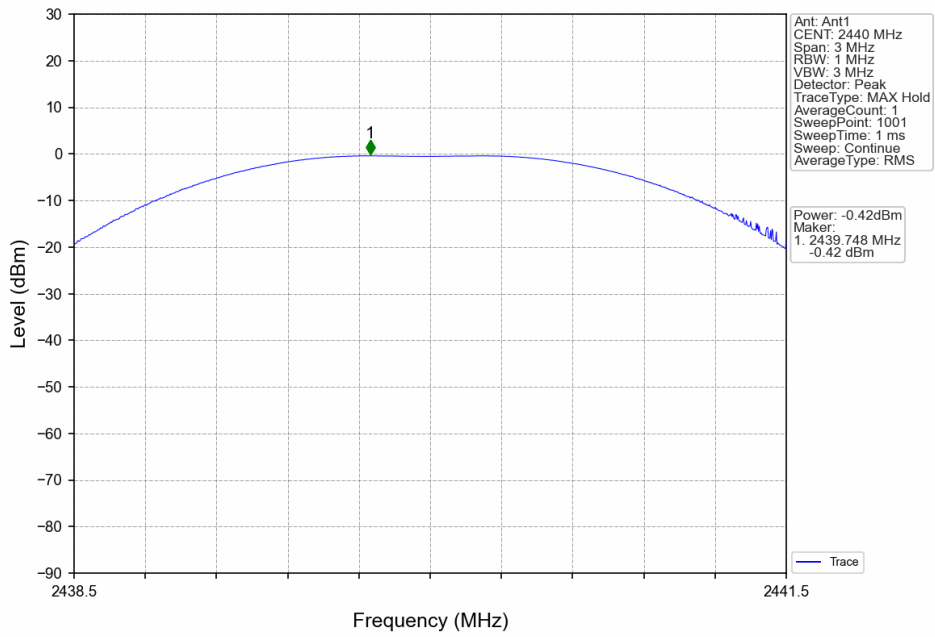

1M_HCH_2480MHz_Ant1_NTNV

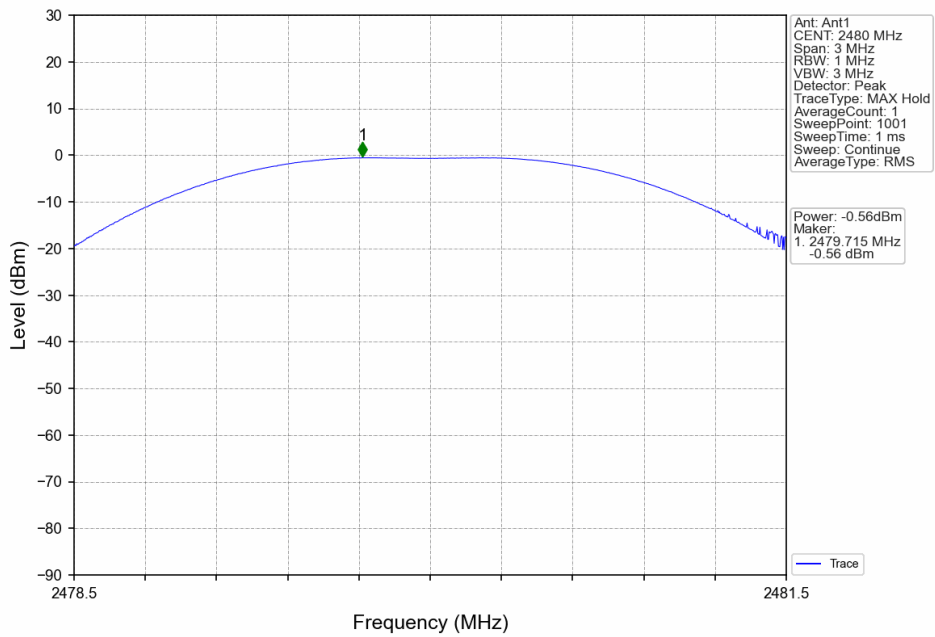

-6dB Bandwidth

Mode	TX Type	Frequency (MHz)	ANT	6dB Bandwidth (MHz)		Verdict
				Result	Limit	
1M	SISO	2402	1	0.676	>=0.5	Pass
		2440	1	0.697	>=0.5	Pass
		2480	1	0.683	>=0.5	Pass

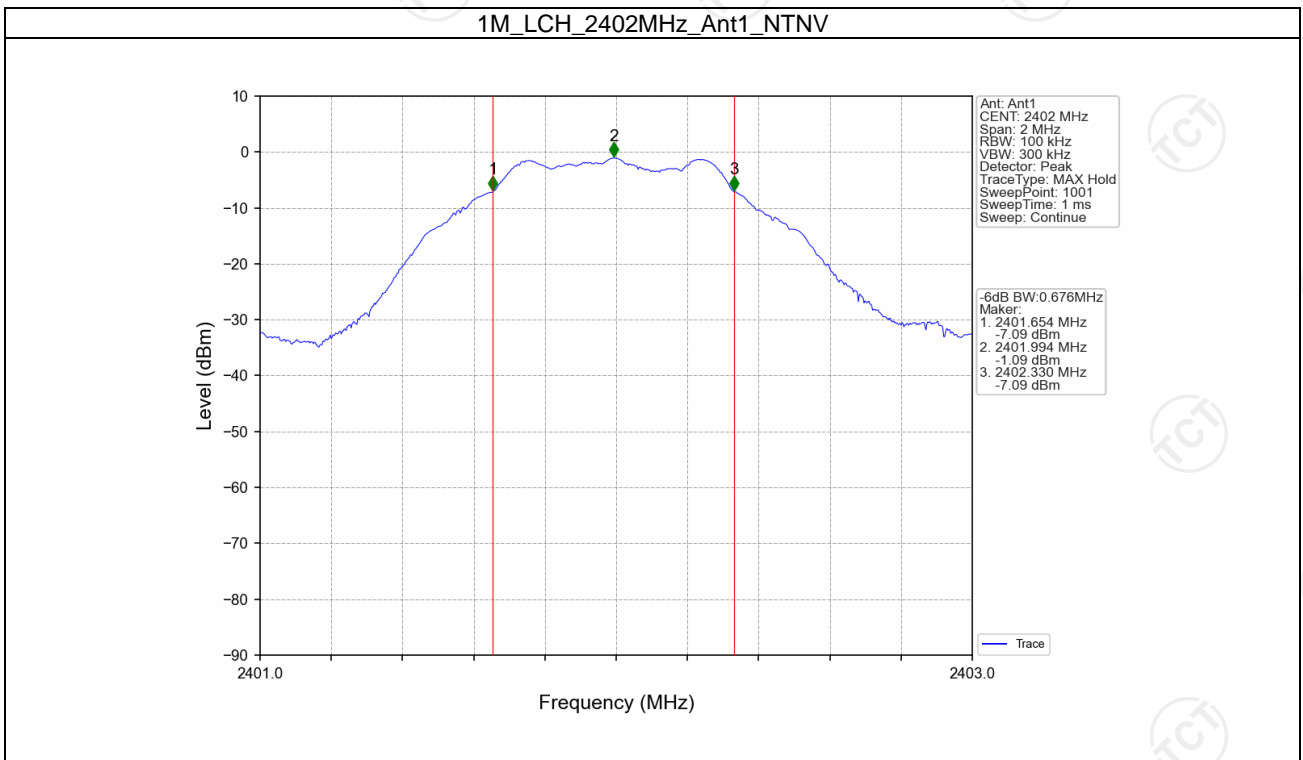

1M_MCH_2440MHz_Ant1_NTNV

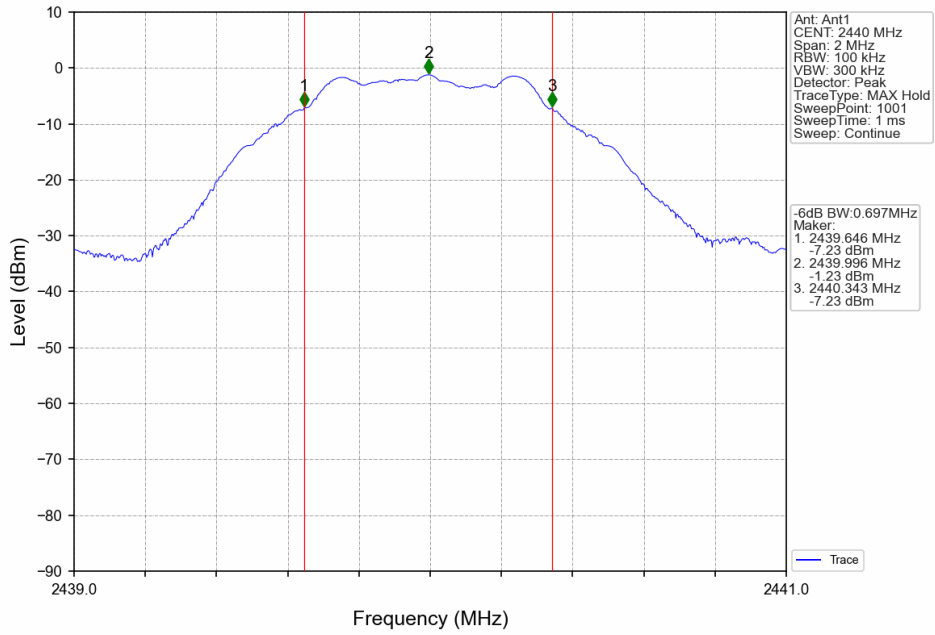

1M_HCH_2480MHz_Ant1_NTNV

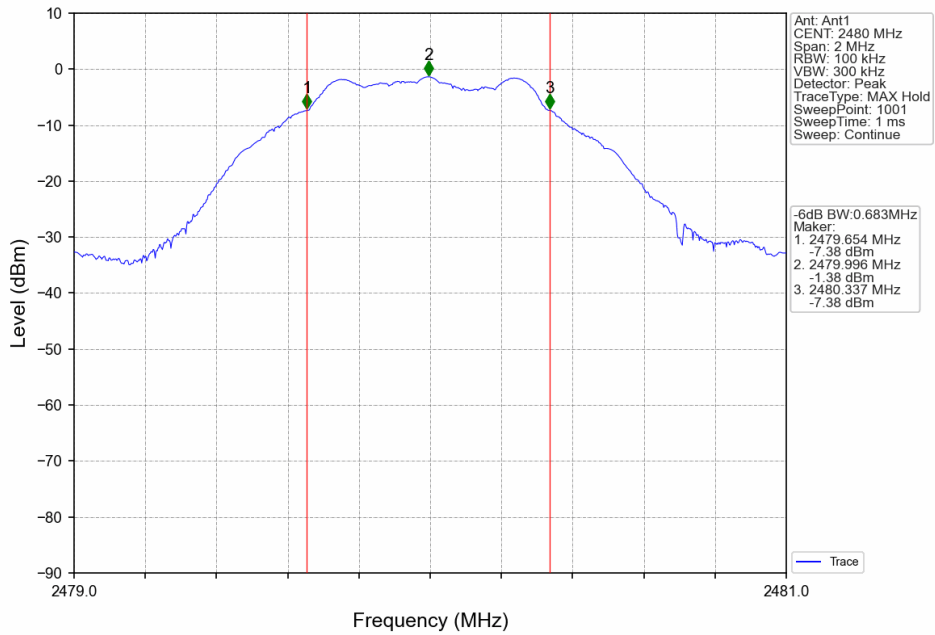

Occupied Channel Bandwidth

Mode	TX Type	Frequency (MHz)	ANT	99% Occupied Bandwidth (MHz)	Verdict
				Result	
1M	SISO	2402	1	1.035	Pass
		2440	1	1.037	Pass
		2480	1	1.038	Pass

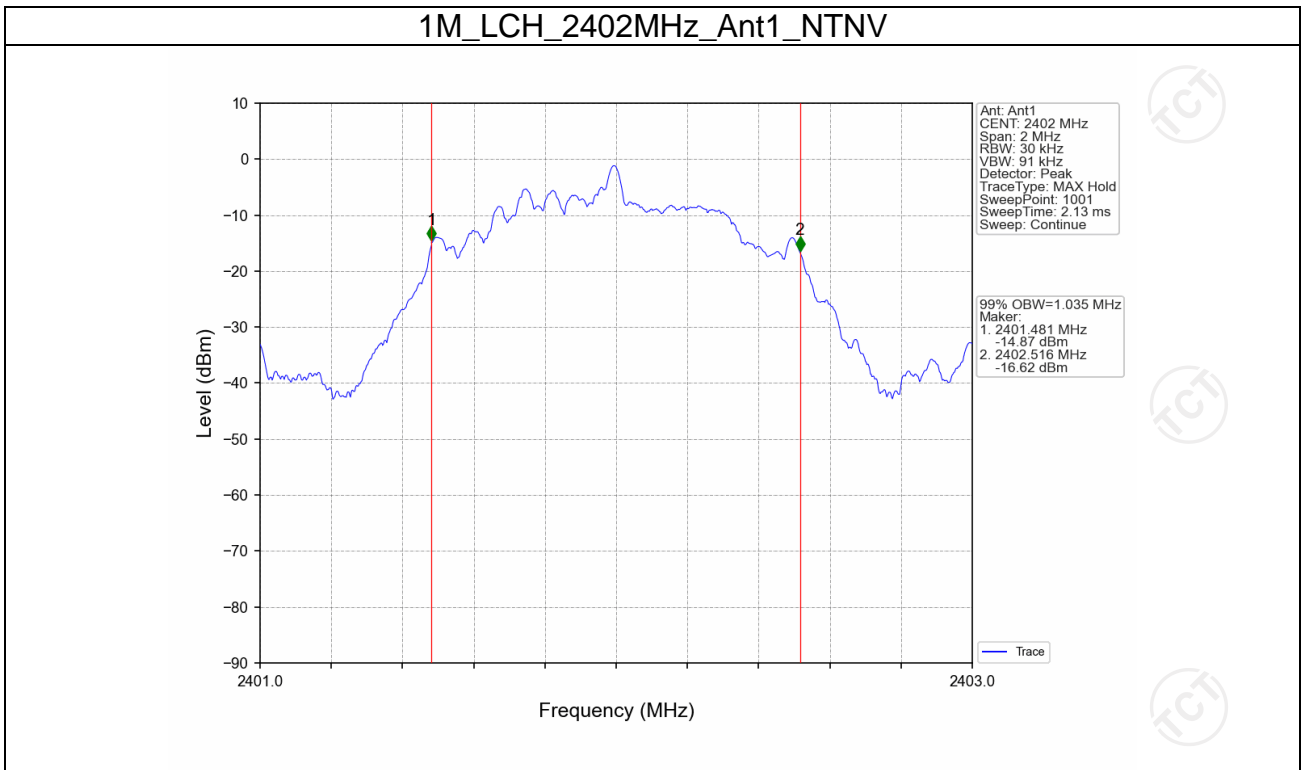

1M_MCH_2440MHz_Ant1_NTNV

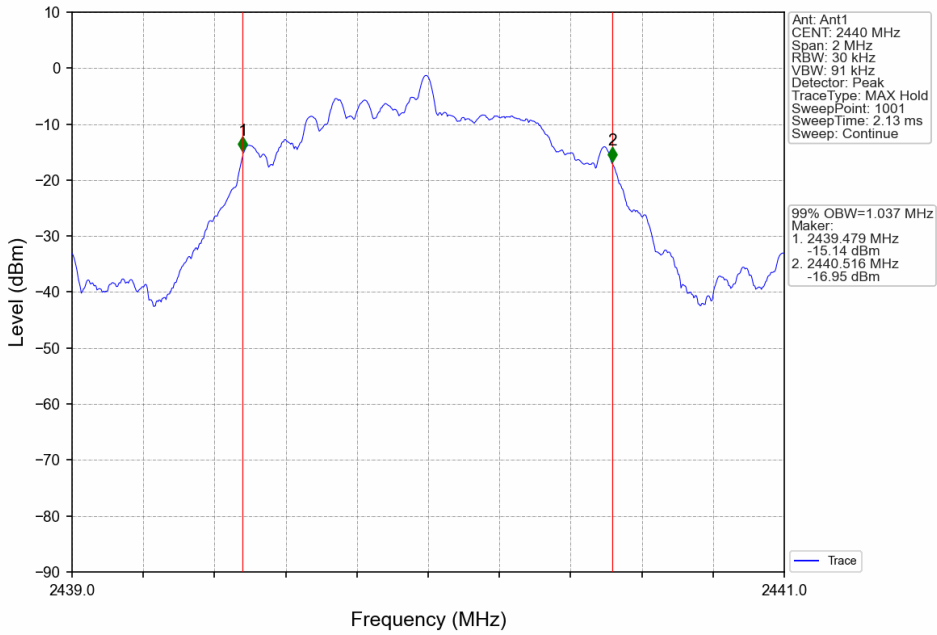

1M_HCH_2480MHz_Ant1_NTNV

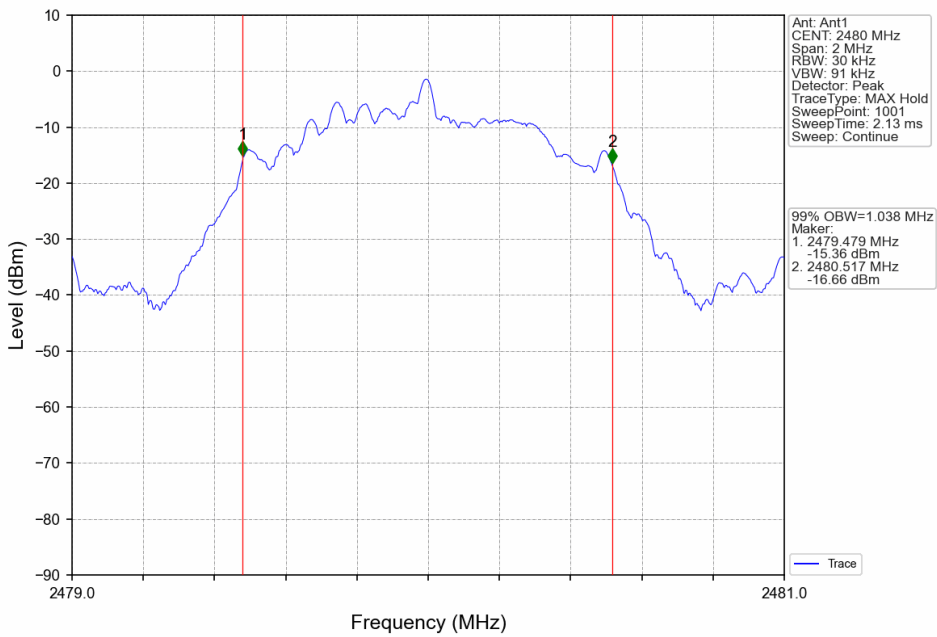

Maximum Power Spectral Density Level

Mode	TX Type	Frequency (MHz)	Maximum PSD (dBm/3kHz)		Verdict
			ANT1	Limit	
1M	SISO	2402	-13.05	<=8	Pass
		2440	-13.20	<=8	Pass
		2480	-13.26	<=8	Pass

Note1: Antenna Gain: Ant1: 0.34dBi;

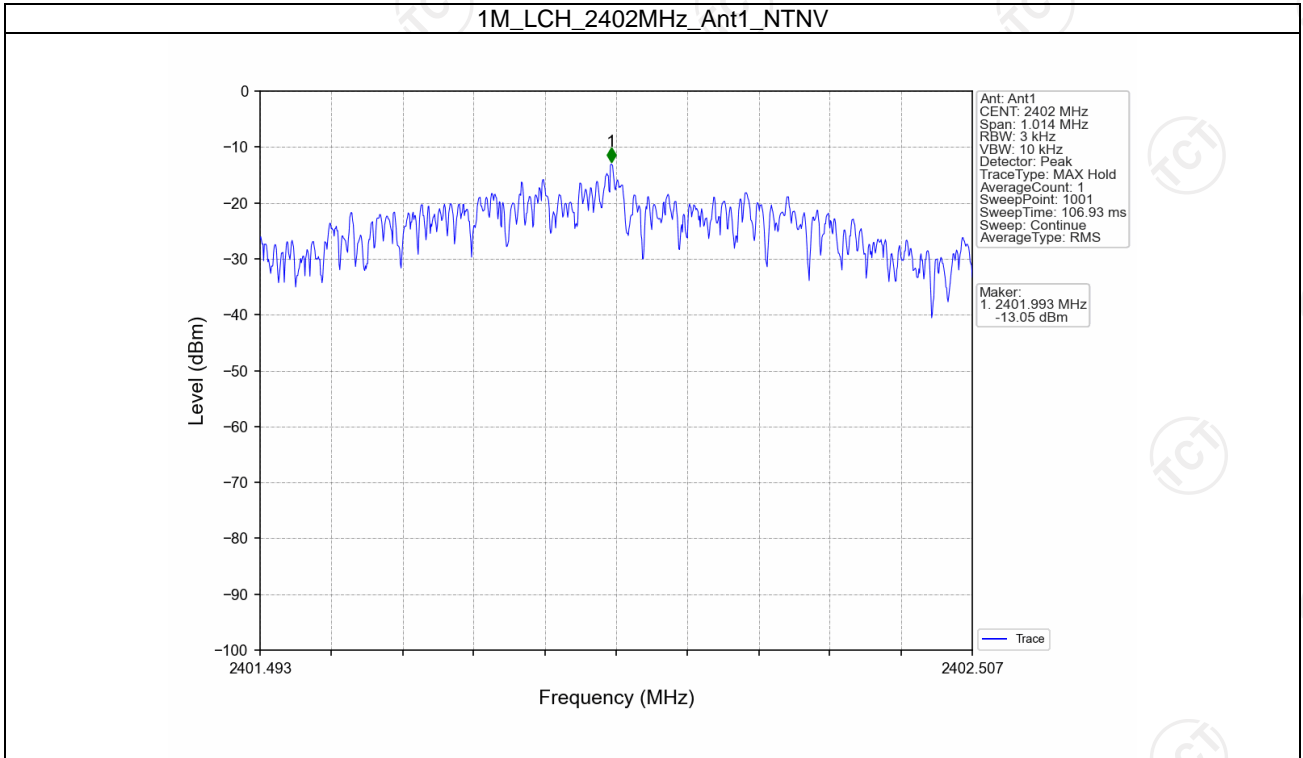

1M_MCH_2440MHz_Ant1_NTNV

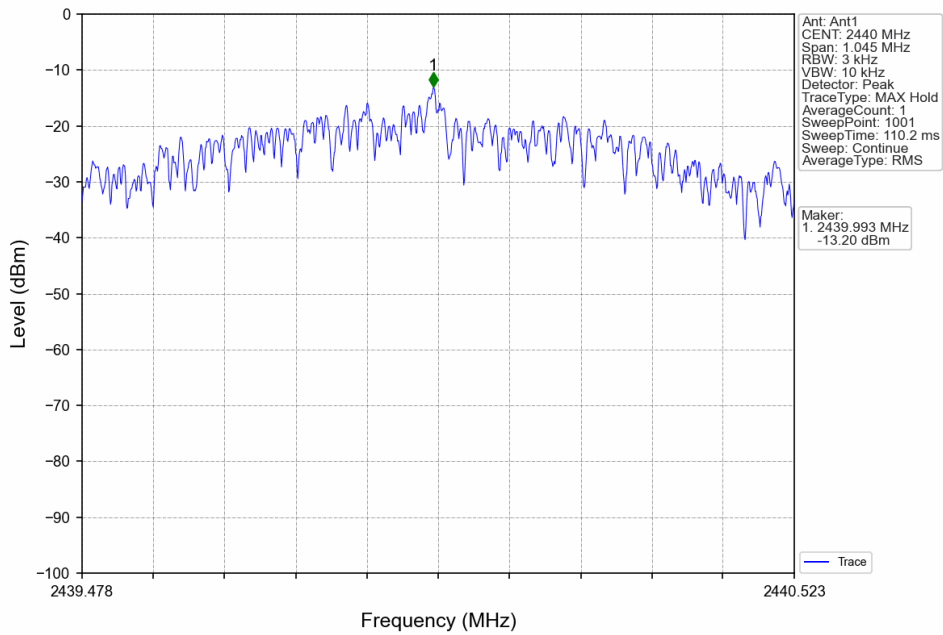

1M_HCH_2480MHz_Ant1_NTNV

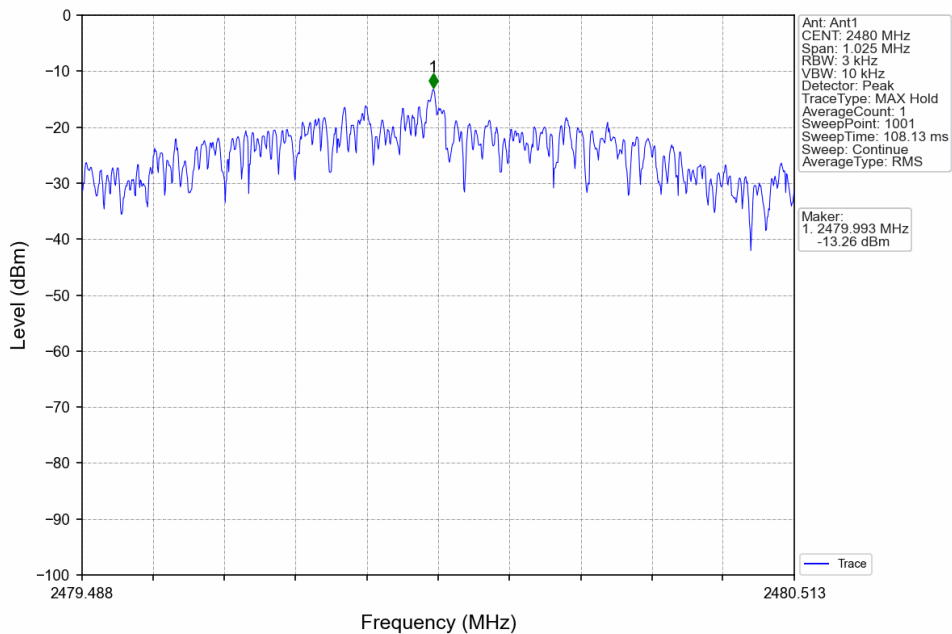

Bandedge & Spurious Emission

Mode	TX Type	Frequency (MHz)	ANT	Level of Reference (dBm)
1M	SISO	2402	1	-1.10
		2440	1	-1.24
		2480	1	-1.40

Note1: Refer to FCC Part 15.247 (d) and ANSI C63.10-2013, the channel contains the maximum PSD level was used to establish the reference level.

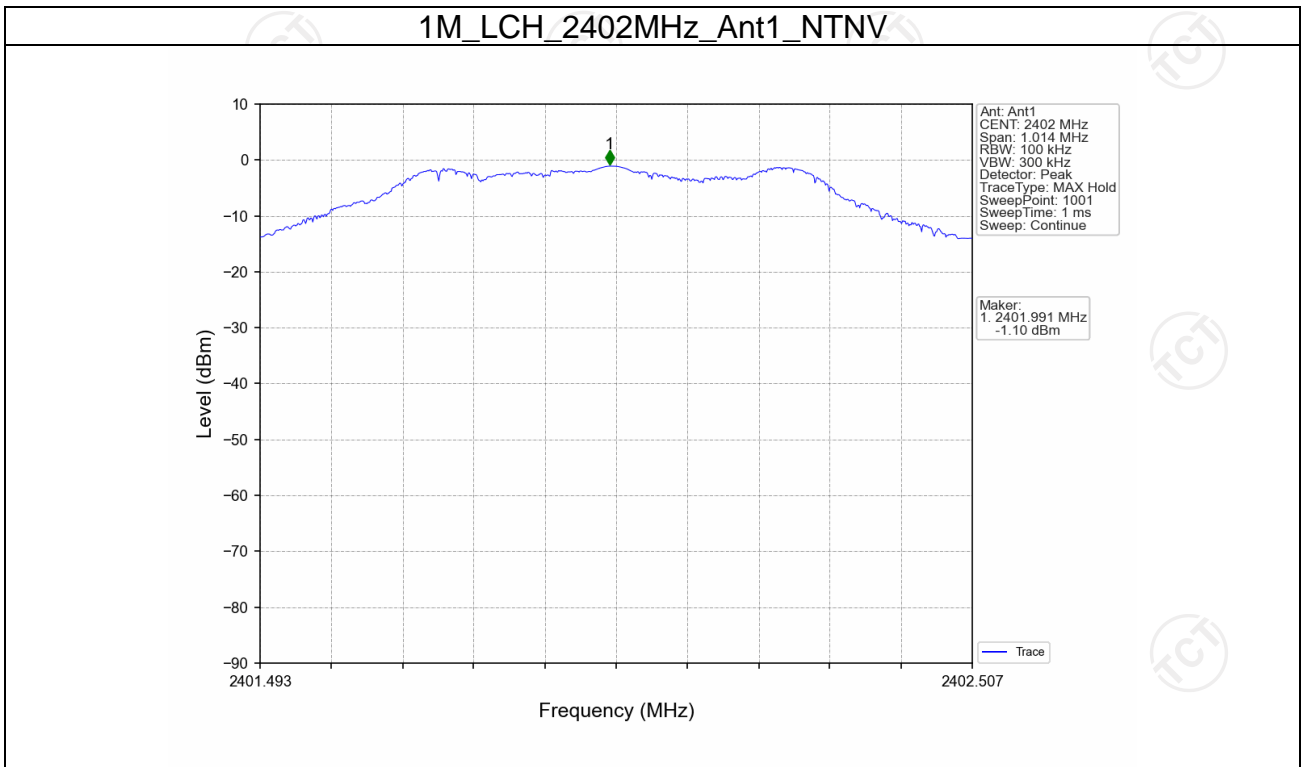

1M_MCH_2440MHz_Ant1_NTNV

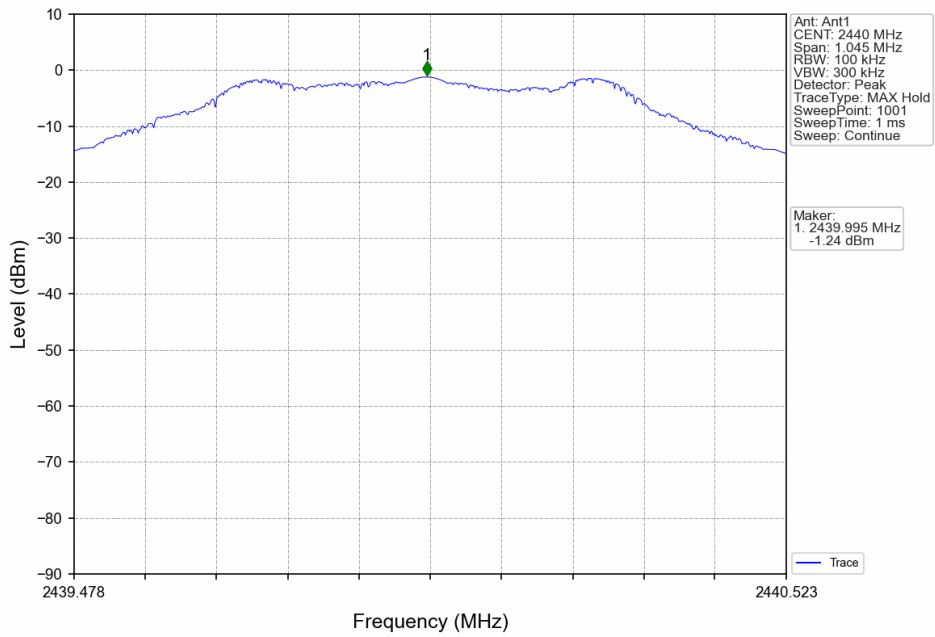

1M_HCH_2480MHz_Ant1_NTNV

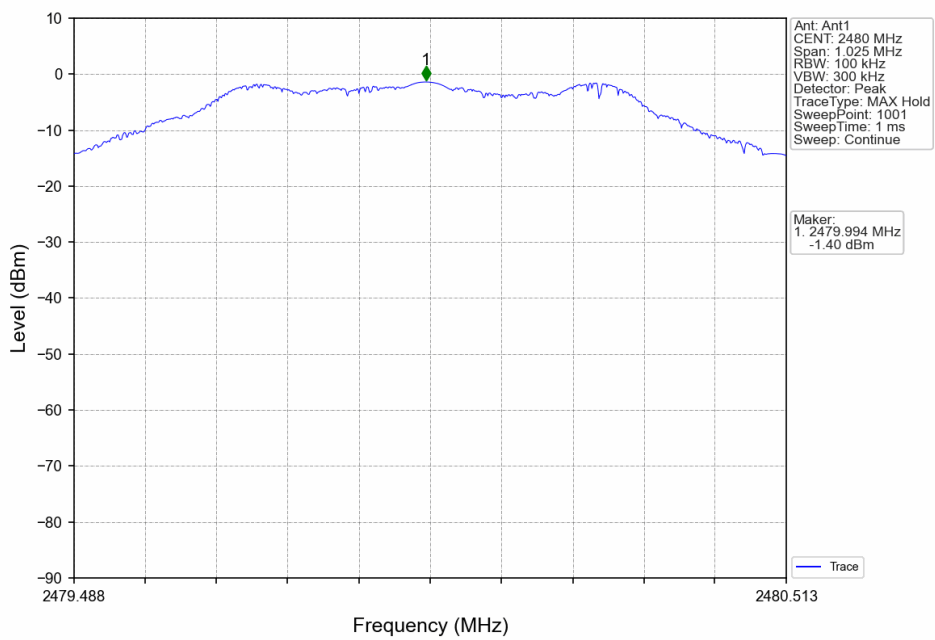

Mode	TX Type	Frequency (MHz)	ANT	Level of Reference (dBm)	Limit (dBm)	Verdict
1M	SISO	2402	1	-1.10	-21.10	Pass
		2440	1	-1.10	-21.10	Pass
		2480	1	-1.10	-21.10	Pass

Note1: Refer to FCC Part 15.247 (d) and ANSI C63.10-2013, the channel contains the maximum PSD level was used to establish the reference level.

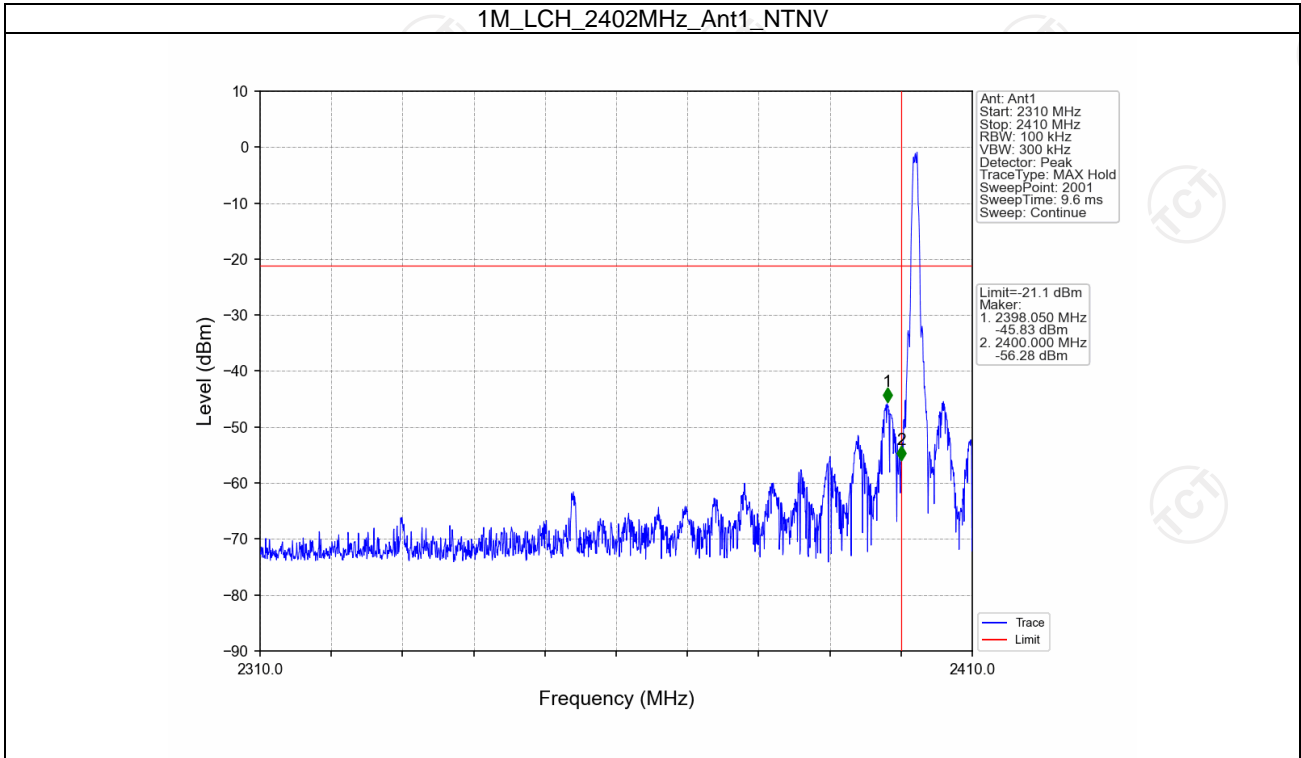

1M_LCH_2402MHz_Ant1_NTNV

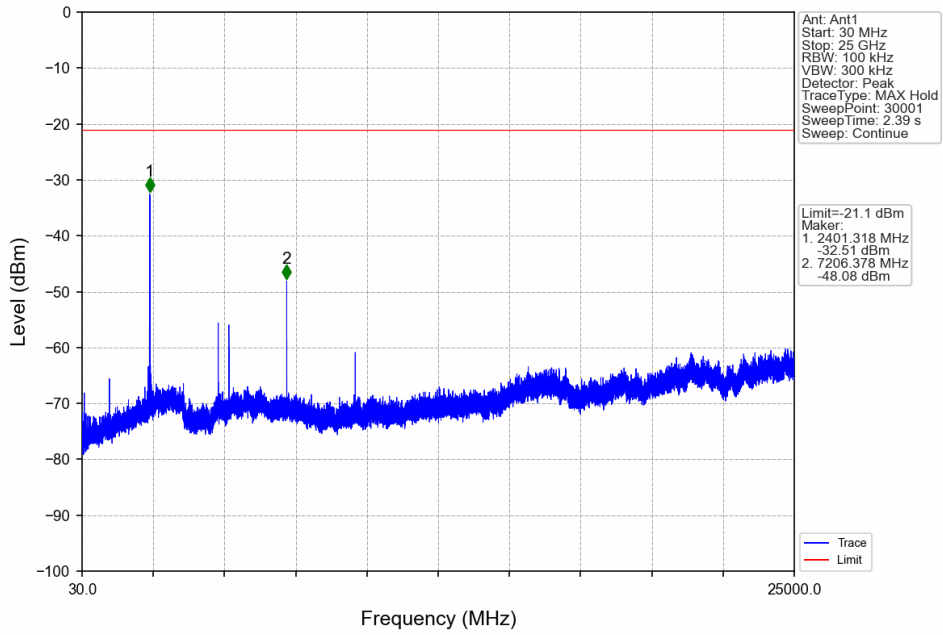

1M_MCH_2440MHz_Ant1_NTNV

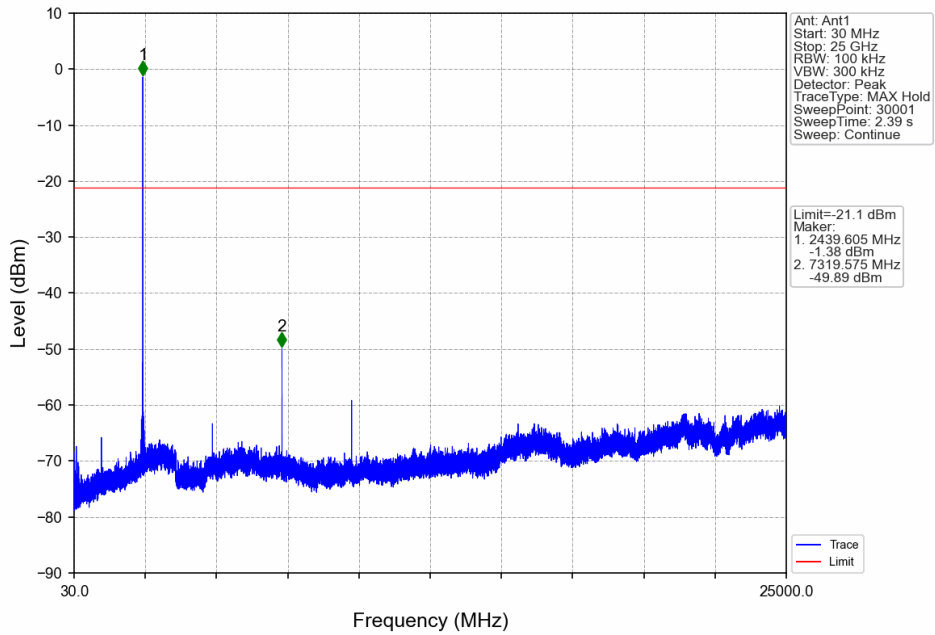

1M_HCH_2480MHz_Ant1_NTNV

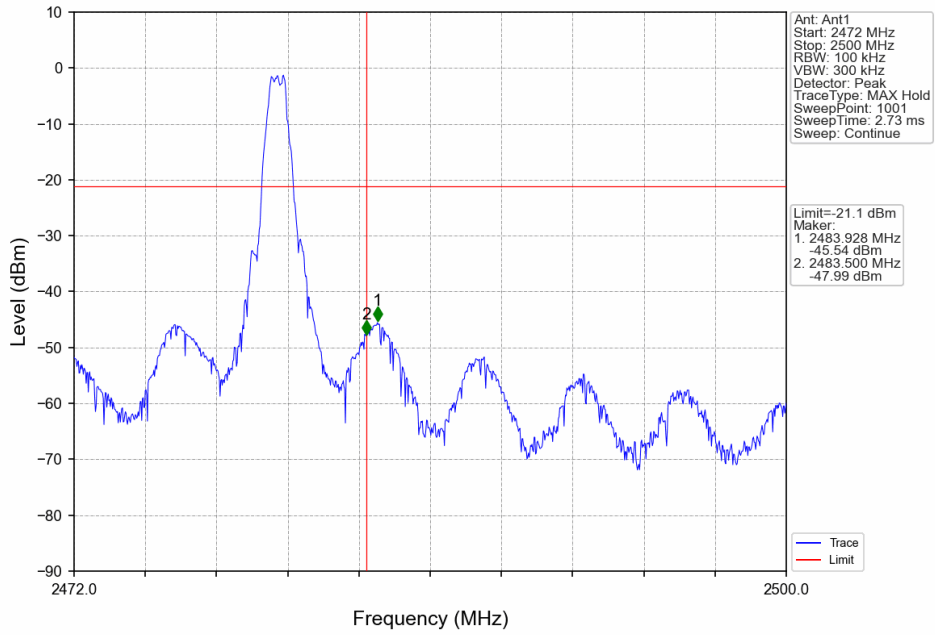

1M_HCH_2480MHz_Ant1_NTNV

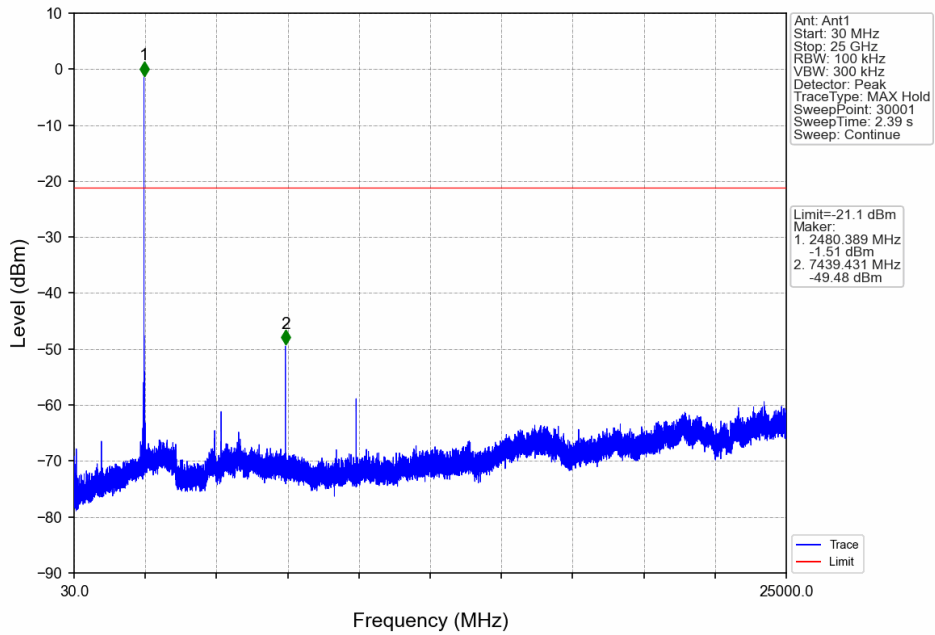

Appendix B: Photographs of Test Setup

Refer to the test report No. TCT221229E016

Appendix C: Photographs of EUT

Refer to the test report No. TCT221229E016

*******END OF REPORT*******