

FCC RADIO TEST REPORT

Applicant/Manufacturer..... : Zhuzhou Zopoise Technology Co., Ltd
Address..... : Phase 2.1 R&D Workshop B and E of Xinma Power Innovation Park 899
Xianyuehuan Road, Tianyuan District, Zhuzhou City, Hunan Province, China
Factory : Zhuzhou Zopoise Technology Co., Ltd
Address : Phase 3.1 Group E Building 2, No.101-103, 1st floor, 201-204 2nd floor
Building B, Xinma Power Valley Innovation Park phase 2.1 R&D workshop,
No.899 Xianyuehuan Road, Tianyuan District, Zhuzhou City, Hunan
Province.
Product Name..... : RFID module
Brand Name..... :  Zopoise
Model No. : ZPS-ARFID, ZPS-BRFID
FCC ID..... : 2A9TQZPS-ARFID
Measurement Standard..... : 47 CFR FCC Part 15, Subpart C (Section 15.225)
Receipt Date of Samples..... : January 06, 2023
Date of Tested..... : January 07, 2023 to February 08, 2023
Date of Report..... : March 16, 2023

This report shows that above equipment is technically compliant with the requirements of the standards above. All test results in this report apply only to the tested sample(s). Without prior written approval of Dongguan Nore Testing Center Co., Ltd, this report shall not be reproduced except in full.

Prepared by
Julie Xiao / Project Engineer

Approved by
Lori Fan / Authorized Signatory

Table of Contents

1. Summary of Test Result.....	4
2. General Description of EUT	5
3. Test Channels and Modes Detail.....	7
4. Configuration of EUT.....	7
5. Modification of EUT.....	7
6. Description of Support Device.....	8
7. Test Facility and Location	9
8. Applicable Standards and References.....	10
9. Deviations and Abnormalities from Standard Conditions	10
10. Test Conditions	10
11. Measurement Uncertainty.....	11
12. Sample Calculations	12
13. Test Items and Results	13
13.1 Conducted Emissions Measurement	13
13.2 Radiated Spurious Emissions Measurement.....	17
13.3 20dB Occupied Bandwidth.....	29
13.4 Frequency Stability.....	31
13.5 Antenna Requirement	33
14. Test Equipment List.....	34

1. Summary of Test Result

FCC Rules	Description of Test	Result	Remarks
§15.207 (a)	AC Power Line Conducted Emission	PASS	---
§15.225 & 15.209 & 15.205	Radiated Spurious Emission	PASS	---
§15.225(e)	Frequency Stability	PASS	---
§15.215(c)	20dB Emission Bandwidth Testing	PASS	---
§15.203	Antenna Requirement	PASS	---
<p>Note: The EUT has been tested as an independent unit.</p>			

2. General Description of EUT

Product Information	
Product Name:	RFID module
Main Model Name:	ZPS-ARFID
Additional Model Name:	ZPS-BRFID
Model Difference:	Both models have the same circuit schematic, construction, PCB Layout and critical components. The difference is model number only due to trading purpose.
S/N:	2301-0129
Brand Name:	 Zopoise
Hardware Version:	Not stated
Software Version:	Not stated
Rating:	DC 4.75-5.25V, 150mA
Typical arrangement:	Table-top / Built-in
I/O Port:	N/A
Accessories Information	
Adapter:	N/A
Cable:	N/A
Other:	N/A
Additional Information	
Note:	According to these model differences, all tests were performed on model ZPS-ARFID according to the manufacturer requirement.
Remark:	All the information above are provided by the manufacturer. More detailed feature of the EUT please refers to the user manual.

Technical Specification	
Declaring the Frequency:	13.56MHz
Modulation Type:	ASK
Antenna Type:	PCB antenna
Antenna Gain:	0 dBi (Declared by manufacturer)
Number of Channels:	1

3. Test Channels and Modes Detail

Mode		Test Frequency (MHz)	Modulation	Data Rate (Mbps)
1	TX	13.56MHz	ASK	---

Note: TX mode means that the EUT was programmed to be in continuously transmitting mode.

4. Configuration of EUT

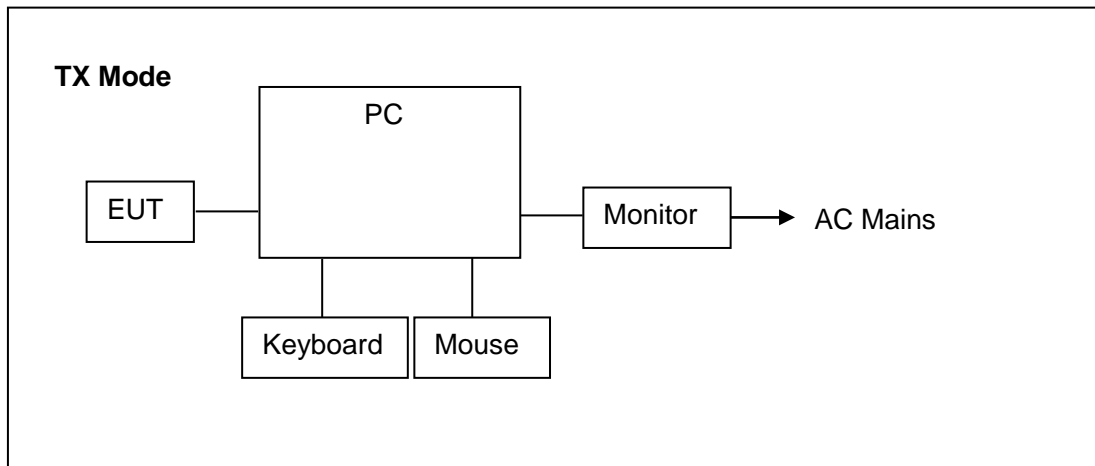

5. Modification of EUT

No modifications are made to the EUT during all test items.

6. Description of Support Device

The EUT has been tested as an independent unit together with other necessary accessories or support units. The following support units or accessories were used to form a representative test configuration during the tests.

No.	Equipment	Brand	M/N	S/N	Cable Specification	Remarks
1.	PC	DELL	OptiPlex 7050	F0F6HP2	Power Cord: 1.8m Unshielded, with core	Provided by the Lab.
2.	Monitor 1	DELL	S2240Tb	CN-0FP53P-7 4261-3AL-0C YU	---	Provided by the Lab.
3.	Monitor 2	Dell	U2718Q	CN-05DWRH-	Power Cord: 1.8m Unshielded, with core	Provided by the Lab.
4.	Keyboard	DELL	KB216d	---	USB Line: 1.21m unshielded	Provided by the Lab.
5.	Mouse	DELL	MS116p	---	USB Line: 1.21m unshielded	Provided by the Lab.

Software	Mode	Power Setting
MT626-CE Test	RFID -TX	Default

7. Test Facility and Location

Test Site	:	Dongguan Nore Testing Center Co., Ltd. (Dongguan NTC Co., Ltd.)
Accreditations and Authorizations	:	<p>The Laboratory has been assessed and proved to be in compliance with CNAS/CL01</p> <p>Listed by CNAS, August 13, 2018</p> <p>The Certificate Registration Number is L5795.</p> <p>The Certificate is valid until August 13, 2024</p> <p>The Laboratory has been assessed and proved to be in compliance with ISO17025</p> <p>Listed by A2LA, November 01, 2017</p> <p>The Certificate Registration Number is 4429.01</p> <p>Listed by FCC, November 06, 2017</p> <p>Test Firm Registration Number: 907417</p> <p>Listed by Industry Canada, June 08, 2017</p> <p>The Certificate Registration Number. Is 46405-9743A</p>
Test Site Location	:	Building D, Gaosheng Science and Technology Park, Hongtu Road, Nancheng District, Dongguan City, Guangdong Province, China

8. Applicable Standards and References

According to the specifications of the manufacturer, the EUT must comply with the requirements of the following standards:

Test Standards:

47 CFR Part 15, Subpart C, 15.225

ANSI C63.10-2013

References Test Guidance:

N/A

9. Deviations and Abnormalities from Standard Conditions

No additions, deviations and exclusions from the standard.

10. Test Conditions

No.	Test Item	Test Mode	Test Voltage	Tested by	Remarks
1.	AC Power Conducted Emission	1	DC 5V	Sean	See note 1
2.	Radiated Emission	1	DC 5V	Sean	See note 1
3.	Frequency Stability	1	DC 5V	Sean	See note 1
4.	20dB Emission Bandwidth Testing	1	DC 5V	Sean	See note 1
5.	Antenna Requirement	1	---	Sean	See note 1

Note:

- The testing climatic conditions for temperature, humidity, and atmospheric pressure are within: 15~35°C, 30~70%, 86~106kPa
- DC 5V come from PC.
- As the EUT can be operated multiple positions, all X,Y,Z axis were considered during the test and only the worst case X was recorded.

11. Measurement Uncertainty

No.	Test Item	Frequency	Uncertainty	Remarks
1.	Conducted Emission	150KHz ~ 30MHz	±2.52 dB	---
2.	Radiated Emission Test	9kHz ~ 30MHz	±5.04 dB	---
		30MHz ~ 1GHz	±5.04 dB	---
		1GHz ~ 18GHz	±5.23 dB	---
		18GHz ~ 40GHz	±5.23 dB	

Note:

1. This uncertainty represents an expanded uncertainty expressed at approximately the 95% confidence level using a coverage factor of k=2.
2. The measurement uncertainty levels above are estimated and calculated according to CISPR 16-4-2.
3. The conformity assessment statement in this report is based solely on the test results, measurement uncertainty is excluded.

12. Sample Calculations

Conducted Emission						
Freq. (MHz)	Reading Level (dBUV)	Correct Factor (dB)	Measurement (dBUV)	Limit (dBUV)	Over (dB)	Detector
0.1580	44.70	10.60	55.30	65.57	-10.27	QP

Where,

Freq. = Emission frequency in MHz

Reading Level = Spectrum Analyzer/Receiver Reading

Corrector Factor = Insertion loss of LISN + Cable Loss + RF Switching Unit attenuation

Measurement = Reading + Corrector Factor

Limit = Limit stated in standard

Margin = Measurement - Limit

Detector = Reading for Quasi-Peak / Average / Peak

Radiated Spurious Emissions						
Freq. (MHz)	Reading Level (dBUV)	Correct Factor (dB/m)	Measurement (dBUV/m)	Limit (dBUV/m)	Over (dB)	Detector
0.0271	30.92	20.49	51.41	118.80	-67.39	QP

Where,

Freq. = Emission frequency in MHz

Reading Level = Spectrum Analyzer/Receiver Reading

Corrector Factor = Antenna Factor + Cable Loss - Pre-amplifier

Measurement = Reading + Corrector Factor

Limit = Limit stated in standard

Over = Margin, which calculated by Measurement - Limit

Detector = Reading for Quasi-Peak / Average / Peak

Note: For all conducted test items, the spectrum analyzer offset or transducer is derived from RF cable loss and attenuator factor. The offset or transducer is equal to the RF cable loss plus attenuator factor.

13. Test Items and Results

13.1 Conducted Emissions Measurement

LIMIT

According to the requirements of FCC PART 15.207, the limits are as follows:

Frequency (MHz)	Quasi-peak	Average
0.15 to 0.5	66 to 56	56 to 46
0.5 to 5	56	46
5 to 30	60	50

- Note:
1. If the limits for the average detector are met when using the quasi-peak detector, then the limits for the measurements with the average detector are considered to be met.
 2. The lower limit shall apply at the transition frequencies.
 3. The limit decreases linearly with the logarithm of the frequency in the range 0.15 MHz to 0.5MHz.

BLOCK DIAGRAM OF TEST SETUP

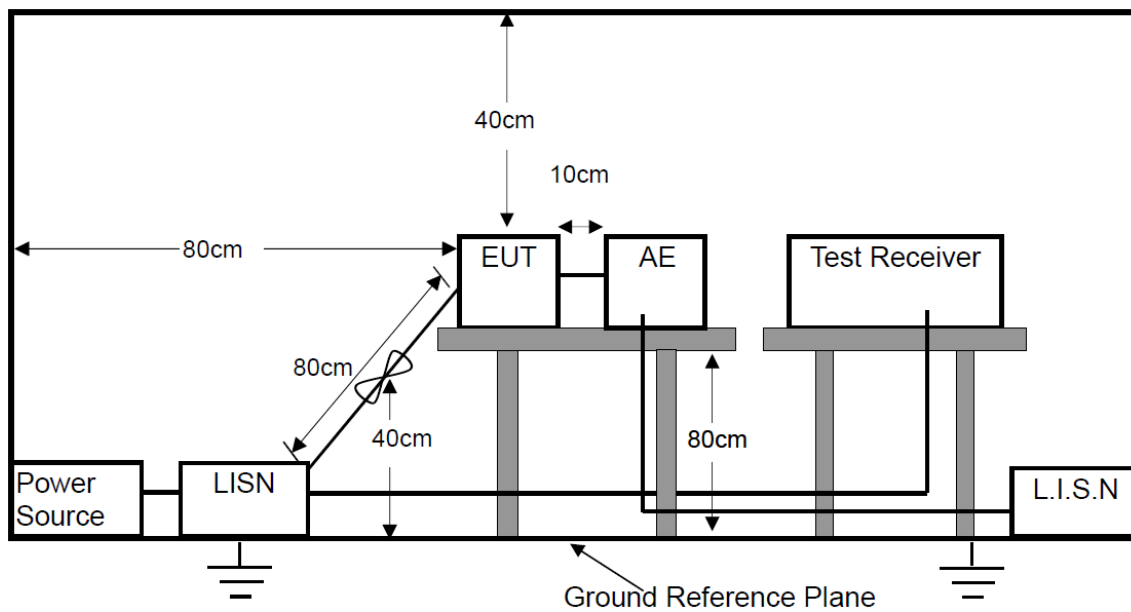

TEST PROCEDURES

- a. The EUT was placed on a wooden table 0.8m height from the metal ground plan and 0.4m from the conducting wall of the shielding room and it was kept at 0.8m from any other grounded conducting surface.
- b. All I/O cables and support devices were positioned as per ANSI C63.10.
- c. Connect mains power port of the EUT to a line impedance stabilization network (LISN).
- d. Connect all support devices to the other LISN and AAN, if needed.
- e. Scan the frequency range from 150KHz to 30MHz at both sides of AC line for maximum conducted interference checking and record the test data.

TEST RESULTS

PASS

Please refer to the following pages.

M/N: ZPS-ARFID	Testing Voltage: DC 5V
Phase: L1	Detector: QP & AVG
Test Mode: 1	

Conducted Emission Measurement

Date: 2023/1/13

Time: 16:02:56

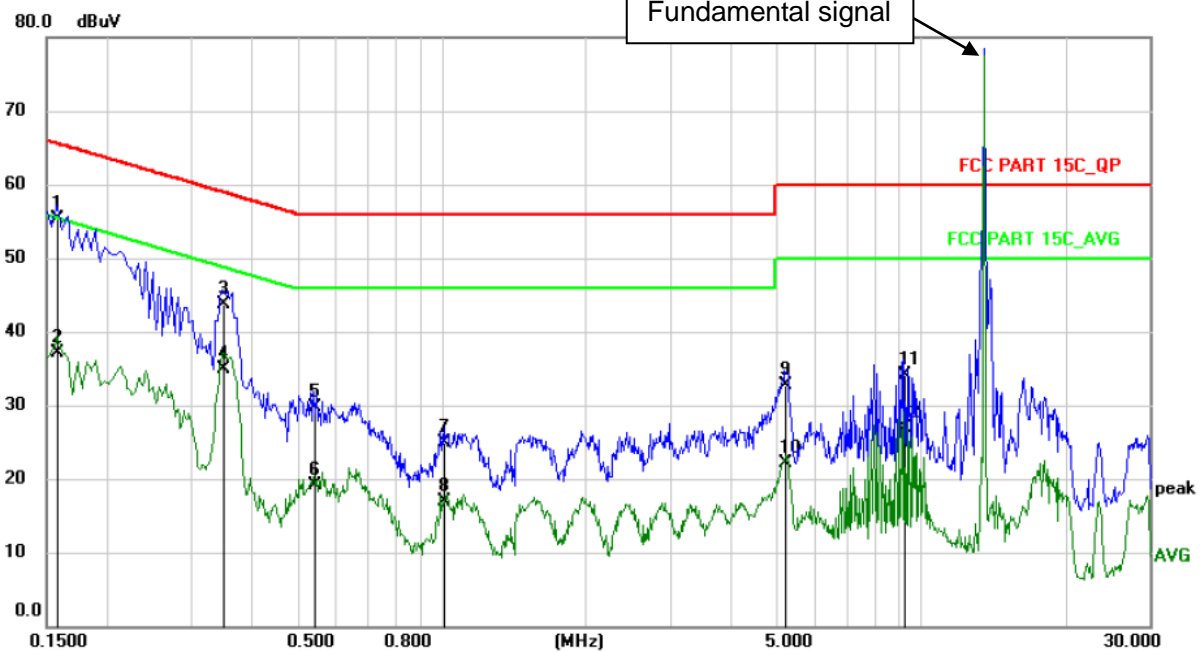

No. Mk.	Freq.	Reading Level	Correct Factor	Measurement	Limit	Over	Detector	Comment
	MHz	dBuV	dB	dBuV	dBuV	dB		
1 *	0.1580	44.70	10.60	55.30	65.57	-10.27	QP	
2	0.1580	26.60	10.60	37.20	55.57	-18.37	AVG	
3	0.3500	33.09	10.61	43.70	58.96	-15.26	QP	
4	0.3500	24.39	10.61	35.00	48.96	-13.96	AVG	
5	0.5420	19.17	10.63	29.80	56.00	-26.20	QP	
6	0.5420	8.57	10.63	19.20	46.00	-26.80	AVG	
7	1.0140	14.20	10.70	24.90	56.00	-31.10	QP	
8	1.0140	6.20	10.70	16.90	46.00	-29.10	AVG	
9	5.2100	21.99	10.71	32.70	60.00	-27.30	QP	
10	5.2100	11.39	10.71	22.10	50.00	-27.90	AVG	
11	9.2460	23.47	10.73	34.20	60.00	-25.80	QP	
12	9.2460	16.27	10.73	27.00	50.00	-23.00	AVG	

M/N: ZPS-ARFID	Testing Voltage: DC 5V
Phase: N	Detector: QP & AVG
Test Mode: 1	

Conducted Emission Measurement

Date: 2023/1/13

Time: 16:09:43

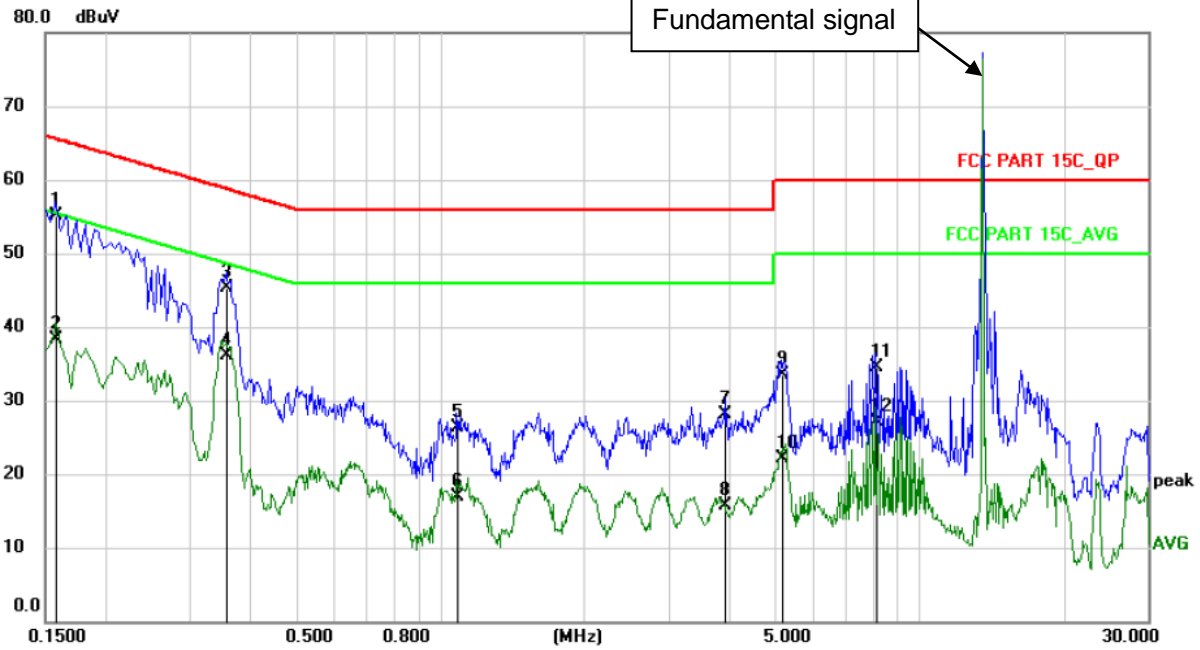

No. Mk.	Freq.	Reading Level	Correct Factor	Measurement	Limit	Over	Detector	Comment
	MHz	dBuV	dB	dBuV	dBuV	dB		
1 *	0.1580	44.50	10.60	55.10	65.57	-10.47	QP	
2	0.1580	27.80	10.60	38.40	55.57	-17.17	AVG	
3	0.3579	34.79	10.61	45.40	58.78	-13.38	QP	
4	0.3579	25.49	10.61	36.10	48.78	-12.68	AVG	
5	1.0859	15.60	10.70	26.30	56.00	-29.70	QP	
6	1.0859	6.30	10.70	17.00	46.00	-29.00	AVG	
7	3.9300	17.49	10.71	28.20	56.00	-27.80	QP	
8	3.9300	4.99	10.71	15.70	46.00	-30.30	AVG	
9	5.1658	22.79	10.71	33.50	60.00	-26.50	QP	
10	5.1658	11.39	10.71	22.10	50.00	-27.90	AVG	
11	8.1059	23.78	10.72	34.50	60.00	-25.50	QP	
12	8.1059	16.38	10.72	27.10	50.00	-22.90	AVG	

13.2 Radiated Spurious Emissions Measurement

LIMIT

Frequency range MHz	Distance Meters	Field Strengths Limit (15.209)
		μV/m
0.009 ~ 0.490	300	2400/F(kHz)
0.490 ~ 1.705	30	24000/F(kHz)
1.705 ~ 30	30	30
30 ~ 88	3	100
88 ~ 216	3	150
216 ~ 960	3	200
Above 960	3	500

- Remark: (1) Emission level (dB)μV = 20 log Emission level μV/m
- (2) The smaller limit shall apply at the cross point between two frequency bands.
- (3) As shown in 15.35(b), for frequencies above 1000MHz, the field strength limits are based on average detector, however, the peak field strength of any emission shall not exceed the maximum permitted average limits, specified above by more than 20dB under any condition of modulation.
- (4) The frequency range scanned is from the lowest radio frequency signal generated in the device which is greater than 9 kHz to the tenth harmonic of the highest fundamental frequency or 40 GHz, whichever is lower.
- (5) §15.247(d) specifies that emissions which fall in the restricted bands, as defined in §15.205 comply with radiated emission limits specified in §15.209.

According to 15.225, the field strength of emissions from intentional radiators operated within these frequency bands shall comply with the following:

- (a) The field strength of any emissions within the band 13.553-13.567MHz shall not exceed 15,848 microvolts/meter at 30 meters.
- (b) Within the bands 13.410-13.553MHz and 13.567-13.710MHz, the field strength of any emissions shall not exceed 334 microvolts/meter at 30 meters.
- (c) Within the bands 13.110-13.410 MHz and 13.710-14.010MHz the field strength of any emissions shall not exceed 106 microvolts/meter at 30 meters.
- (d) The field strength of any emissions appearing outside of the 13.110-14.010MHz band shall not exceed the general radiated emission limits in 15.209.

BLOCK DIAGRAM OF TEST SETUP

For Radiated Emission below 30MHz

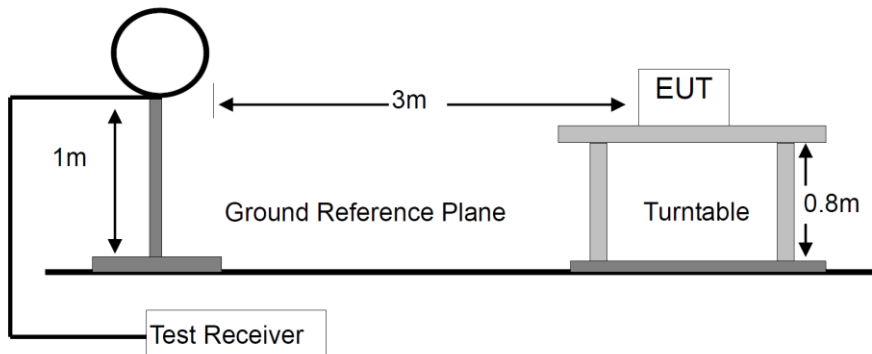

For Radiated Emission 30-1000MHz

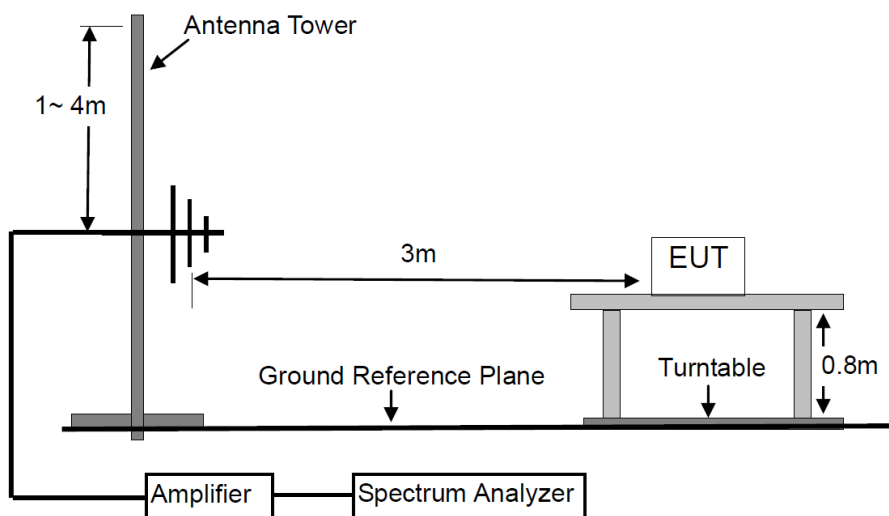

For Radiated Emission Above 1000MHz.

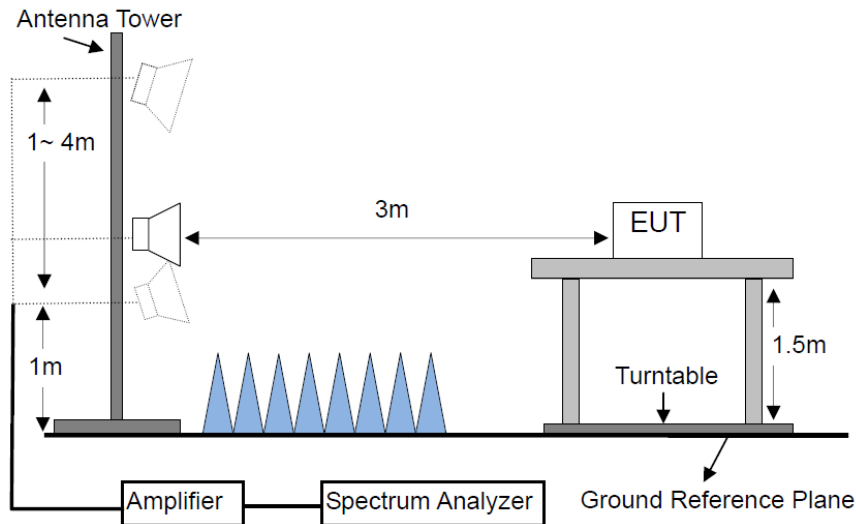

TEST PROCEDURES

- a. Below 1GHz, the EUT was placed on the top of a rotating table 0.8 meters above the ground at a 3 meter semi- anechoic chamber room.
- b. For the radiated emission test above 1GHz:

The EUT was placed on the top of a rotating table 1.5 meters above the ground at a 3 meter full anechoic chamber room. The table was rotated 360 degrees to determine the position of the highest radiation. Place the measurement antenna away from each area of the EUT determined to be a source of emissions at the specified measurement distance, while keeping the measurement antenna aimed at the source of emissions at each frequency of significant emissions, with polarization oriented for maximum response. The measurement antenna may have to be higher or lower than the EUT, depending on the radiation pattern of the emission and staying aimed at the emission source for receiving the maximum signal. The final measurement antenna elevation shall be that which maximizes the emissions. The measurement antenna elevation for maximum emissions shall be restricted to a range of heights of from 1 m to 4 m above the ground or reference ground plane.
- c. The EUT was set 3 meters away from the interference-receiving antenna, which was mounted on the top of a variable-height antenna tower.

- d. The height of antenna is varied from one meter to four meters above the ground to determine the maximum value of the field strength. Both horizontal and vertical polarizations of the antenna are set to make the measurement.
- e. For each suspected emission, the EUT was arranged to its worst case and then the antenna was tuned to heights from 1 meter to 4 meters and the rotatable table was turned from 0 degrees to 360 degrees to find the maximum reading. The test-receiver system was set to peak detect function and specified bandwidth with maximum hold mode.
- f. A Quasi-peak measurement was then made for that frequency point for below 1GHz test. PK and AV for above 1GHz emission test.
- g. Pre-Scan has been conducted to determine the worst-case mode from all possible combinations between available modulations, data rates, XYZ axis and packet type.

The worst case was found when the EUT was positioned on X axis for radiated emission.

During the radiated emission test, the spectrum analyzer was set with the following configurations:

Frequency Band (MHz)	Detector	Resolution Bandwidth	Video Bandwidth
0.009~0.15	QP & AVG	200Hz	1KHz
0.15 -30	QP & AVG	9KHz	30KHz
30 to 1000	QP	120 kHz	300 kHz
Above 1000	Peak	1 MHz	3 MHz
	Average	1 MHz	10 Hz

TEST RESULTS

PASS

Please refer to the following pages.

M/N: ZPS-ARFID	Testing Voltage: DC 5V
Polarization: Horizontal	Detector: Peak
Test Mode: TX	Distance: 3m

Radiated Emission Measurement

Date: 2023/1/13

Time: 12:07:36

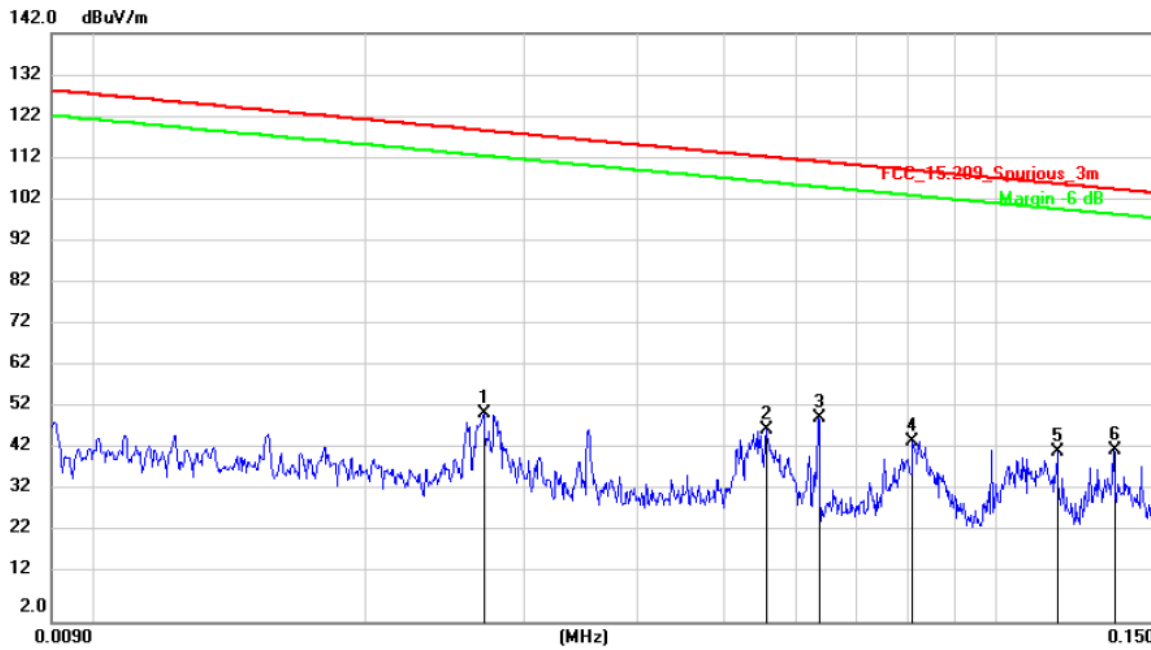

No.	Mk.	Freq.	Reading Level	Correct Factor	Measurement	Limit	Over	Detector	Comment
		MHz	dBuV	dB/m	dBuV/m	dBuV/m	dB		
1		0.0271	30.92	20.49	51.41	118.80	-67.39	peak	
2		0.0557	27.00	20.58	47.58	112.58	-65.00	peak	
3	*	0.0636	29.88	20.53	50.41	111.44	-61.03	peak	
4		0.0810	24.34	20.53	44.87	109.35	-64.48	peak	
5		0.1171	21.91	20.53	42.44	106.16	-63.72	peak	
6		0.1352	22.26	20.53	42.79	104.92	-62.13	peak	

Note: Since the measured peak emission levels are lower the allowable limit more than 6dB, the QP and AVG emission levels are considered compliance with the limit as well.

M/N: ZPS-ARFID	Testing Voltage: DC 5V
Polarization: Vertical	Detector: Peak
Test Mode: TX	Distance: 3m

Radiated Emission Measurement

Date: 2023/1/13

Time: 12:26:04

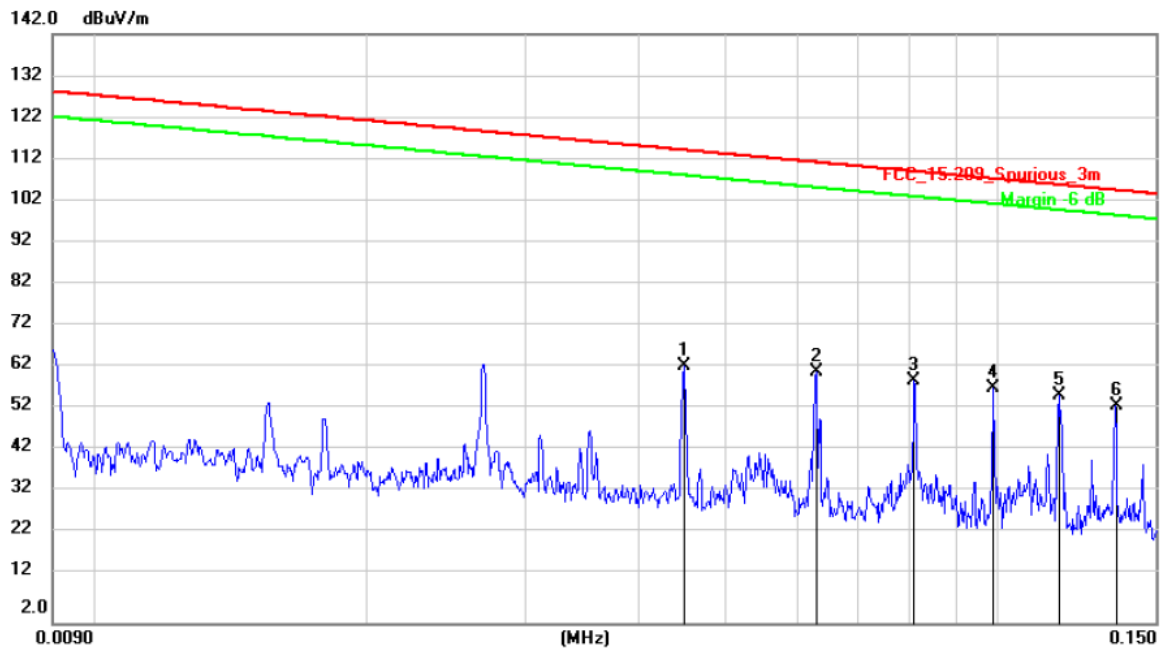

No.	Mk.	Freq.	Reading Level	Correct Factor	Measurement	Limit	Over	Detector	Comment
		MHz	dBuV	dB/m	dBuV/m	dBuV/m	dB		
1		0.0450	42.62	20.59	63.21	114.42	-51.21	peak	
2		0.0631	41.11	20.53	61.64	111.50	-49.86	peak	
3	*	0.0810	39.20	20.53	59.73	109.35	-49.62	peak	
4		0.0991	37.26	20.54	57.80	107.61	-49.81	peak	
5		0.1171	35.71	20.53	56.24	106.16	-49.92	peak	
6		0.1352	33.24	20.53	53.77	104.92	-51.15	peak	

Note: Since the measured peak emission levels are lower the allowable limit more than 6dB, the QP and AVG emission levels are considered compliance with the limit as well.

M/N: ZPS-ARFID	Testing Voltage: DC 5V
Polarization: Horizontal	Detector: Peak
Test Mode: TX	Distance: 3m

Radiated Emission Measurement

Date: 2023/1/13

Time: 12:13:54

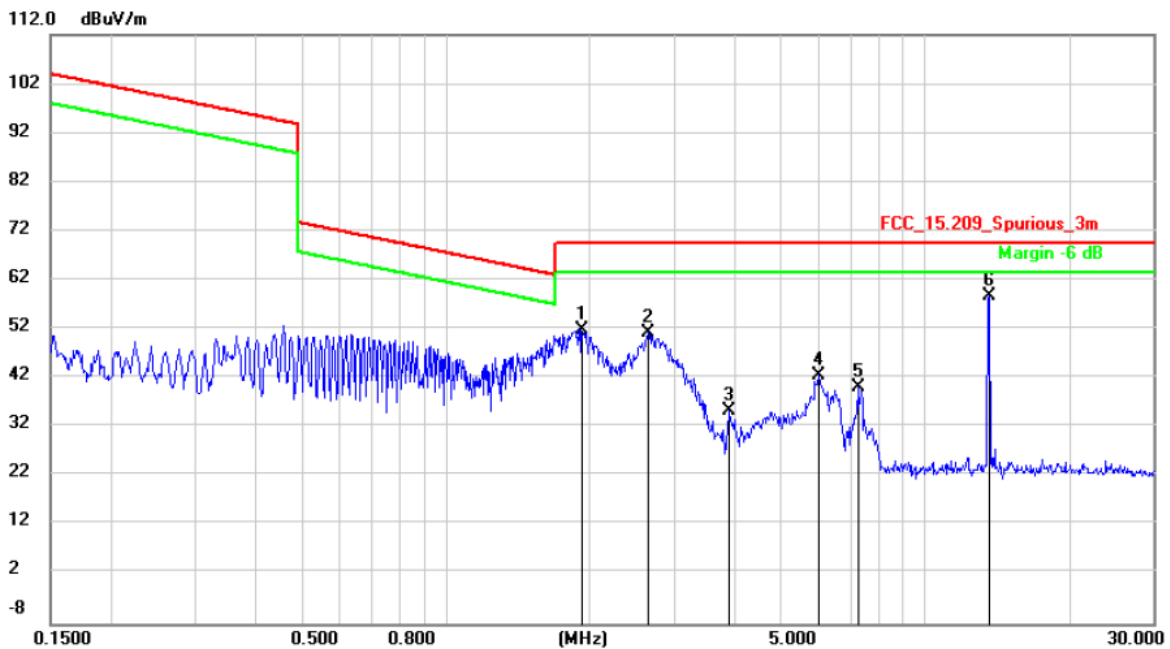

No.	Mk.	Freq.	Reading Level	Correct Factor	Measurement	Limit	Over	Detector	Comment
		MHz	dBuV	dB/m	dBuV/m	dBuV/m	dB		
1		1.9182	31.36	20.40	51.76	69.50	-17.74	peak	
2		2.6500	30.93	20.40	51.33	69.50	-18.17	peak	
3		3.9014	14.87	20.43	35.30	69.50	-34.20	peak	
4		5.9925	22.03	20.46	42.49	69.50	-27.01	peak	
5		7.2518	19.55	20.50	40.05	69.50	-29.45	peak	
6	*	13.5600	38.17	20.56	58.73	69.50	-10.77	peak	

Note: Since the measured peak emission levels are lower the allowable limit more than 6dB, the QP and AVG emission levels are considered compliance with the limit as well.

M/N: ZPS-ARFID	Testing Voltage: DC 5V
Polarization: Vertical	Detector: Peak
Test Mode: TX	Distance: 3m

Radiated Emission Measurement

Date: 2023/1/13

Time: 12:20:13

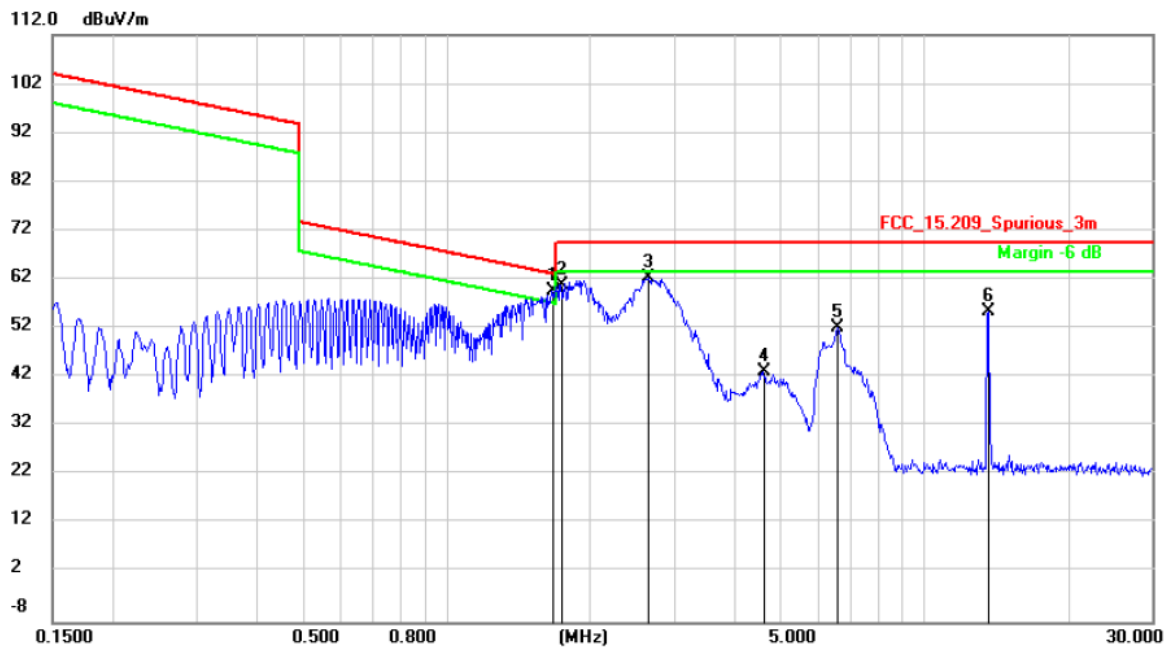

No.	Mk.	Freq.	Reading Level	Correct Factor	Measurement	Limit	Over	Detector	Comment
		MHz	dBuV	dB/m	dBuV/m	dBuV/m	dB		
1	*	1.6625	39.18	20.40	59.58	63.19	-3.61	peak	
2		1.7345	40.50	20.40	60.90	69.50	-8.60	peak	
3		2.6500	41.82	20.40	62.22	69.50	-7.28	peak	
4		4.5979	22.65	20.45	43.10	69.50	-26.40	peak	
5		6.5921	31.82	20.48	52.30	69.50	-17.20	peak	
6		13.5600	34.76	20.56	55.32	69.50	-14.18	peak	

Note: Since the measured peak emission levels are lower the allowable limit more than 6dB, the QP and AVG emission levels are considered compliance with the limit as well.

M/N: ZPS-ARFID	Testing Voltage: DC 5V
Polarization: Horizontal	Detector: Peak
Test Mode: TX	Distance: 3m

Radiated Emission Measurement

Date: 2023/1/13

Time: 12:38:32

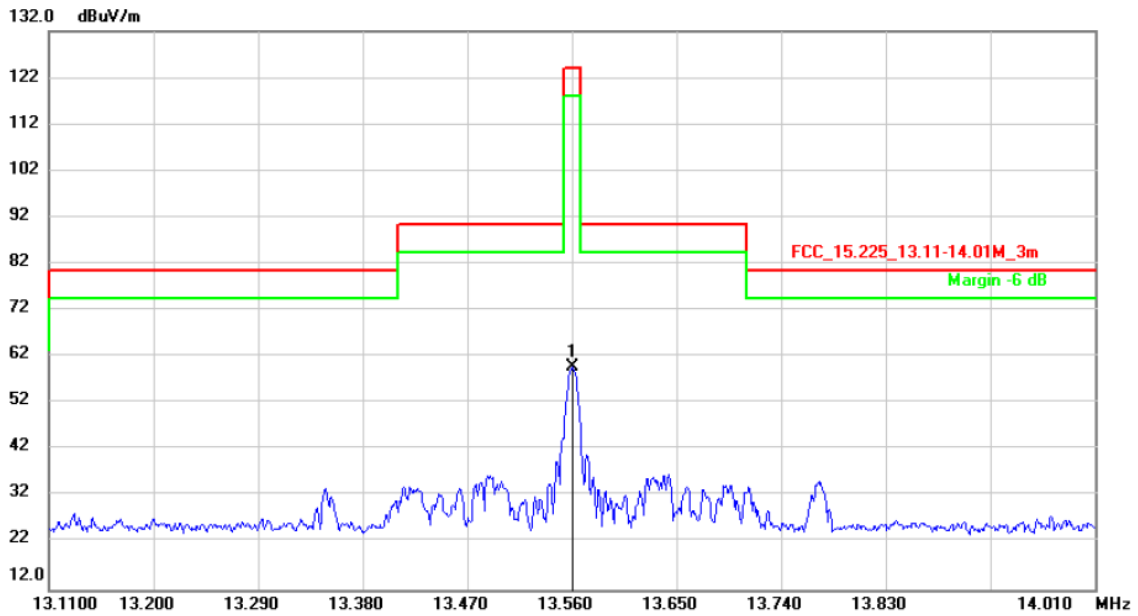

No.	Mk.	Freq.	Reading Level	Correct Factor	Measurement	Limit	Over	Detector	Comment
		MHz	dBuV	dB/m	dBuV/m	dBuV/m	dB		
1	*	13.5600	39.16	20.56	59.72	124.00	-64.28	peak	

M/N: ZPS-ARFID	Testing Voltage: DC 5V
Polarization: Vertical	Detector: Peak
Test Mode: TX	Distance: 3m

Radiated Emission Measurement

Date: 2023/1/13

Time: 12:32:38

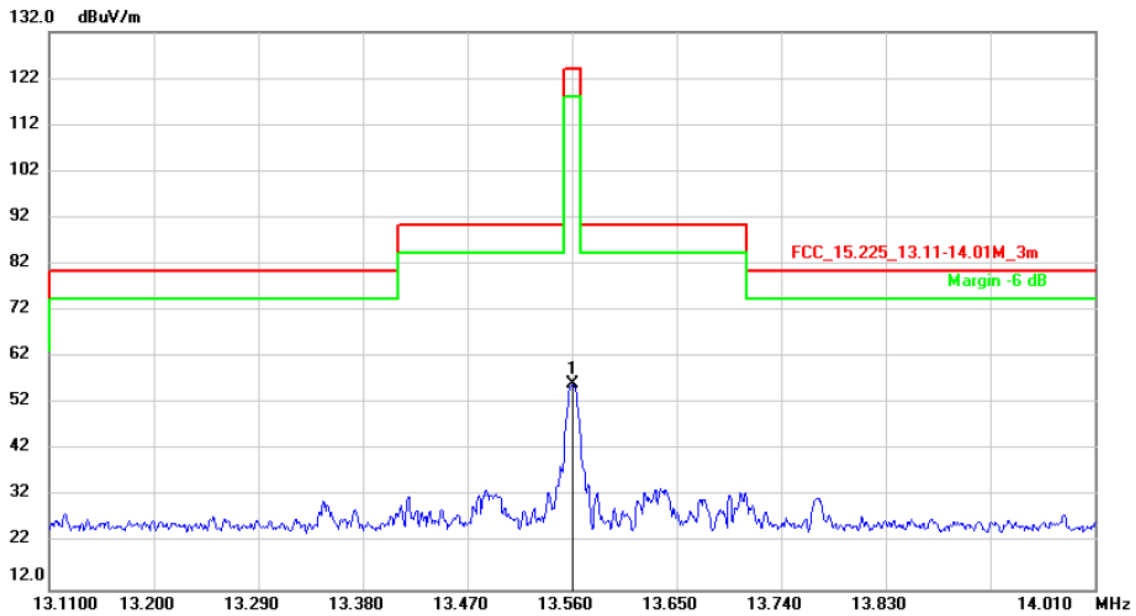

No.	Mk.	Freq.	Reading Level	Correct Factor	Measurement	Limit	Over	Detector	Comment
		MHz	dBuV	dB/m	dBuV/m	dBuV/m	dB		
1	*	13.5600	35.65	20.56	56.21	124.00	-67.79	peak	

M/N: ZPS-ARFID	Testing Voltage: DC 5V
Polarization: Horizontal	Detector: QP
Test Mode: TX	Distance: 3m

Radiated Emission Measurement

Date: 2023/2/8

Time: 16:48:40

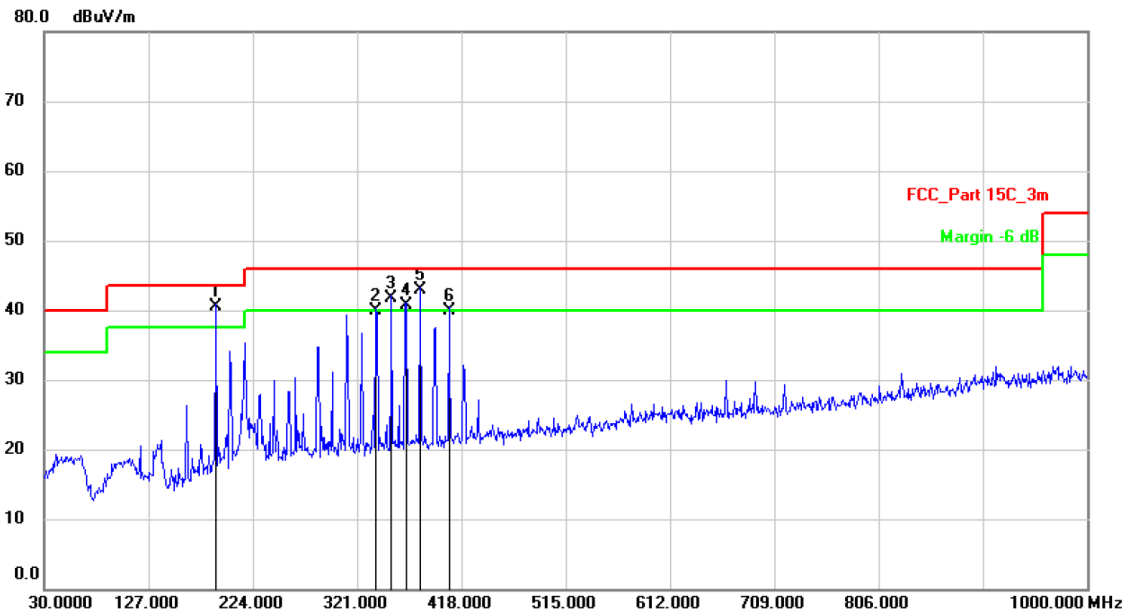

No.	Mk.	Freq.	Reading Level	Correct Factor	Measurement	Limit	Over	Detector	Comment
		MHz	dBuV	dB/m	dBuV/m	dBuV/m	dB		
1	*	190.0500	48.77	-8.27	40.50	43.50	-3.00	QP	
2		338.4600	44.37	-4.37	40.00	46.00	-6.00	QP	
3	!	353.0100	45.91	-4.11	41.80	46.00	-4.20	QP	
4	!	366.5900	44.63	-3.93	40.70	46.00	-5.30	QP	
5	!	379.2000	46.66	-3.76	42.90	46.00	-3.10	QP	
6		406.3599	43.13	-3.23	39.90	46.00	-6.10	QP	

M/N: ZPS-ARFID	Testing Voltage: DC 5V
Polarization: Vertical	Detector: QP
Test Mode: TX	Distance: 3m

Radiated Emission Measurement

Date: 2023/2/8

Time: 16:54:15

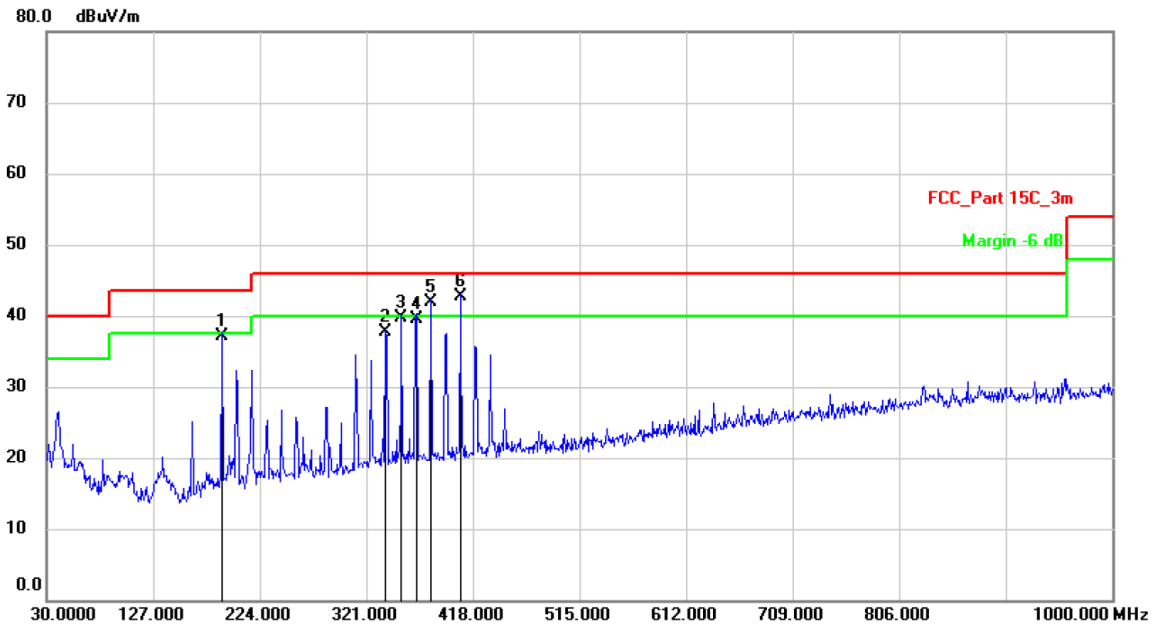

No.	Mk.	Freq.	Reading Level	Correct Factor	Measurement	Limit	Over	Detector	Comment
		MHz	dBuV	dB/m	dBuV/m	dBuV/m	dB		
1		190.0500	46.19	-9.09	37.10	43.50	-6.40	QP	
2		338.4600	43.17	-5.37	37.80	46.00	-8.20	QP	
3		353.0100	44.91	-5.11	39.80	46.00	-6.20	QP	
4		366.5900	44.43	-4.93	39.50	46.00	-6.50	QP	
5	!	379.2000	46.66	-4.76	41.90	46.00	-4.10	QP	
6	*	406.3599	47.03	-4.23	42.80	46.00	-3.20	QP	

13.3 20dB Occupied Bandwidth

LIMIT

According to 15.215 (C), Intentional radiators operating under the alternative provisions to the general emission limits, as contained in 15.217 through 15.257 and in subpart E of this part, must be designed to ensure that the 20 dB bandwidth of the emission, or whatever bandwidth may otherwise be specified in the specific rule section under which the equipment operates, is contained within the frequency band designated in the rule section under which the equipment is operated. In the case of intentional radiators operating under the provisions of subpart E, the emission bandwidth may span across multiple contiguous frequency bands identified in that subpart. The requirement to contain the designated bandwidth of the emission within the specified frequency band includes the effects from frequency sweeping, frequency hopping and other modulation techniques that may be employed as well as the frequency stability of the transmitter over expected variations in temperature and supply voltage. If a frequency stability is not specified in the regulations, it is recommended that the fundamental emission be kept within at least the central 80% of the permitted band in order to minimize the possibility of out-of-band operation.

BLOCK DIAGRAM OF TEST SETUP

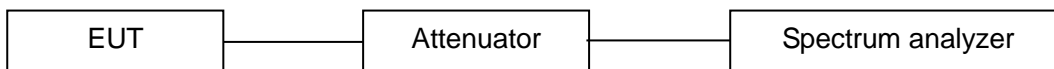

TEST PROCEDURES

1. The output port (antenna) from the transmitter was connected to an attenuator and then to the input of the RF Spectrum analyzer.
2. Spectrum analyzer set the corresponding parameters for measurement and record the tested data

TEST RESULTS

PASS

Please refer to the following table.

Frequency (MHz)	20 dB Bandwidth (KHz)	Result
13.56	28.15	PASS

Test Photo



13.4 Frequency Stability

LIMIT

15.225 (e) The frequency tolerance of the carrier signal shall be maintained within 0.01 % of the operating frequency over a temperature variation of -20 degrees to + 50 degrees C at normal supply voltage, and for a variation in the primary supply voltage from 85% to 115% of the rated supply voltage at a temperature of 20 degrees C. For battery operated equipment, the equipment tests shall be performed using a new battery.

BLOCK DIAGRAM OF TEST SETUP

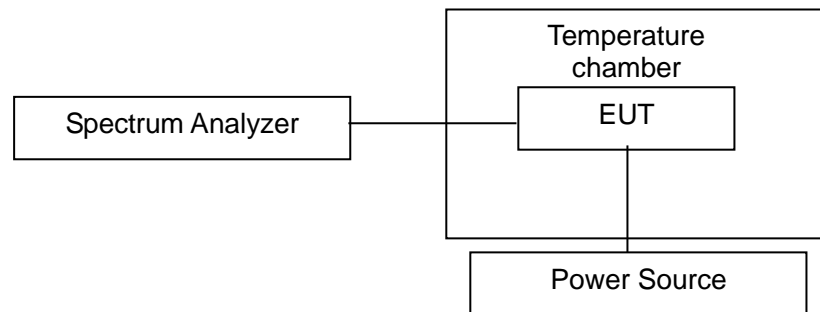

TEST PROCEDURES

- a. The EUT was placed inside the environmental test chamber and powered by Power source.
- b. Turn the EUT on and couple its output to a spectrum analyzer.
- c. Turn the EUT off and set the chamber to the highest temperature specified.
- d. Allow sufficient time (approximately 30 min) for the temperature of the chamber to stabilize, turn the EUT on and measure the operating frequency after 2, 5, and 10 minutes.
- e. Repeat step 2 and 3 with the temperature chamber set to the lowest temperature.
- f. The chamber was allowed to stabilize at +20 degree C for a minimum of 30 minutes. The supply voltage was then adjusted on the EUT from 85% to 115% and the frequency record.

Note: The EUT set at un-modulation mode during frequency stability test.

TEST RESULTS

PASS

Please refer to the following table.

Frequency (MHZ)	Temperature (°C)	Power Supplied (Vdc)	Measurement Frequency (MHZ)	Frequency Error (%)	Limit	Test Result
13.56	-20	5.0	13.56038	0.00280%	±0.01%	Pass
	-10		13.56048	0.00354%	±0.01%	Pass
	0		13.56058	0.00428%	±0.01%	Pass
	10		13.56087	0.00642%	±0.01%	Pass
	20		13.56011	0.00081%	±0.01%	Pass
	30		13.56054	0.00398%	±0.01%	Pass
	40		13.56053	0.00391%	±0.01%	Pass
	50		13.56072	0.00531%	±0.01%	Pass
	20	4.5	13.56019	0.00140%	±0.01%	Pass
	20	5.5	13.56024	0.00177%	±0.01%	Pass

13.5 Antenna Requirement

STANDARD APPLICABLE

According to of FCC part 15C section 15.203 and 15.240:

An intentional radiator shall be designed to ensure that no antenna other than that furnished by the responsible party shall be used with the device. The use of a permanently attached antenna or of an antenna that uses a unique coupling to the intentional radiator, the manufacturer may design the unit so that a broken antenna can be replaced by the user, but the use of a standard antenna jack or electrical connector is prohibited.

ANTENNA CONNECTED CONSTRUCTION

The antenna is PCB antenna that no antenna other than furnished by the responsible party shall be used with the device, and the best case gain of the antenna is 0dBi, Therefore, the antenna is consider meet the requirement.

14. Test Equipment List

Item	Equipment	Manufacturer	Model No.	Serial No.	Last Cal.	Cal. Interval
1.	Test Receiver	Rohde & Schwarz	ESCI7	100837	Mar. 13, 2022	1 Year
2.	Antenna	Schwarzbeck	VULB9162	9162-010	Mar. 23, 2022	2 Year
3.	Spectrum Analyzer	Rohde & Schwarz	FSU26	200409/026	Mar. 13, 2022	1 Year
4.	Spectrum Analyzer	Keysight	N9020A	MY54200831	Mar. 13, 2022	1 Year
5.	Spectrum Analyzer	Keysight	N9010B	1215146	Sep. 06, 2022	1 Year
6.	Horn Antenna	Schwarzbeck	BBHA9170	9170-172	Mar. 23, 2021	2 Year
7.	Power Sensor	DARE	RPR3006W	15I00041SNO 64	Mar. 13, 2022	1 Year
8.	Horn Antenna	COM-Power	AH-118	071078	Mar. 23, 2022	2 Year
9.	Pre-Amplifier	HP	HP 8449B	3008A00964	Mar. 13, 2022	1 Year
10.	Pre-Amplifier	HP	HP 8447D	1145A00203	Mar. 13, 2022	1 Year
11.	Loop Antenna	Schwarzbeck	FMZB 1513	1513-272	Mar. 23, 2022	2 Year
12.	Test Receiver	Rohde & Schwarz	ESCI	101152	Mar. 13, 2022	1 Year
13.	L.I.S.N	Rohde & Schwarz	ENV 216	101317	Mar. 13, 2022	1 Year
14.	RF Switching Unit	Compliance Direction Systems Inc.	RSU-M2	38311	Mar.13, 2022	1 Year
15.	Temporary antenna connector	TESCOM	SS402	N/A	N/A	N/A
16.	Temperature & Humidity Chamber	REMAFEE	SYHR225L	N/A	Mar. 13, 2022	1 Year
17.	Test Software	EZ	EZ_EMCC NTC-3A1.1	N/A	N/A	N/A

Note: For photographs of EUT and measurement, please refer to appendix in separate documents.

---End---