



# RF TEST REPORT

Product Name: Smart phone

Model Name: A540, A54

FCC ID: 2A9SNA540

Issued For : INOI Limited

Office 302, Dominion Centre 43-59, Queens Road, East Wanchai,  
Hong Kong, China

Issued By : Shenzhen LGT Test Service Co., Ltd.

Room 205, Building 13, Zone B, Zhenxiong Industrial Park, No.177,  
Renmin West Road, Jinsha, Kengzi Street, Pingshan District,  
Shenzhen, Guangdong, China

Report Number: LGT24C095RF07

Sample Received Date: Mar. 20, 2024

Date of Test: Mar. 20, 2024 – Apr. 03, 2024

Date of Issue: Apr. 03, 2024

The test report is effective only with both signature and specialized stamp. This report shall not be reproduced except in full without the written approval of the Laboratory. The results in this report only apply to the tested sample.

# TEST REPORT CERTIFICATION

**Applicant:** INOI Limited  
**Address:** Office 302, Dominion Centre 43-59, Queens Road, East Wanchai, Hong Kong, China  
**Manufacturer:** INOI Limited  
**Address:** Office 302, Dominion Centre 43-59, Queens Road, East Wanchai, Hong Kong, China  
**Product Name:** Smart phone  
**Trademark:** INOI  
**Model Name:** A540, A54  
**Sample Status:** Normal

APPLICABLE STANDARDS	
STANDARD	TEST RESULTS
FCC Part 22, 24, 27, 90 KDB 971168 D01 v03r01, ANSI C63.26(2015)	PASS

Prepared by:

Zane Shan

Zane Shan  
Engineer

Approved by:

Vita Li

Vita Li  
Technical Director



## Table of Contents

Page

<b>1. TEST FACTORY &amp; MEASUREMENT UNCERTAINTY</b>	<b>5</b>
<b>2. GENERAL INFORMATION</b>	<b>6</b>
<b>3. CONDUCTED OUTPUT POWER</b>	<b>12</b>
<b>4. PEAK-TO-AVERAGE RATIO</b>	<b>13</b>
<b>5. RADIATED POWER AND EFFECTIVE ISOTROPIC RADIATED POWER</b>	<b>14</b>
<b>6. OCCUPIED BANDWIDTH</b>	<b>16</b>
<b>7. CONDUCTED BAND EDGE</b>	<b>17</b>
<b>8. CONDUCTED SPURIOUS EMISSION</b>	<b>19</b>
<b>9. RADIATED SPURIOUS EMISSION</b>	<b>20</b>
<b>10. FREQUENCY STABILITY</b>	<b>22</b>
<b>APPENDIX I - TEST DATA</b>	<b>23</b>
<b>CONDUCTED OUTPUT POWER</b>	<b>23</b>
<b>FREQUENCY STABILITY</b>	<b>42</b>
<b>PEAK-TO-AVERAGE RATIO</b>	<b>47</b>
<b>OCCUPIED BANDWIDTH</b>	<b>98</b>
<b>BAND EDGE</b>	<b>149</b>
<b>OUT-OF-BAND EMISSIONS</b>	<b>217</b>
<b>RADIATED SPURIOUS EMISSION</b>	<b>268</b>

**Revision History**

Rev.	Issue Date	Revisions
00	Apr. 03, 2024	Initial Issue

# 1. TEST FACTORY & MEASUREMENT UNCERTAINTY

## 1.1 TEST FACTORY

Company Name:	Shenzhen LGT Test Service Co., Ltd.
Address:	Room 205, Building 13, Zone B, Zhenxiong Industrial Park, No.177, Renmin West Road, Jinsha, Kengzi Street, Pingshan District, Shenzhen, Guangdong, China
Accreditation Certificate	A2LA Certificate No.: 6727.01
	FCC Registration No.: 746540
	CAB ID: CN0136

## 1.2 MEASUREMENT UNCERTAINTY

The reported uncertainty of measurement  $y \pm U$ , where expanded uncertainty  $U$  is based on a standard uncertainty multiplied by a coverage factor of  $k=2$ , providing a level of confidence of approximately 95 %.

Parameter	Uncertainty
Occupied Channel Bandwidth	$\pm 3.2 \%$
RF Output Power, Conducted	$\pm 0.87\text{dB}$
Power Spectral Density, Conducted	$\pm 2.11 \text{ dB}$
Unwanted Emission, Conducted	$\pm 0.86\text{dB}$
All Emissions, Radiated (Below 1GHz)	$\pm 3.54\text{dB}$
All Emissions, Radiated (1GHz-18GHz)	$\pm 4.22\text{dB}$
All Emissions, Radiated (18GHz-25GHz)	$\pm 4.81\text{dB}$
Temperature	$\pm 0.5^\circ\text{C}$
Humidity	$\pm 2\%$

Note: The measurement uncertainty is not included in the test result.

## 2. GENERAL INFORMATION

### 2.1 TECHNICAL SPECIFICATIONS AND REGULATIONS

#### 2.1.1 PRODUCT DESCRIPTION

A major technical description of EUT is described as following:

Product Name:	Smart phone
Trademark:	INOI
Model Name:	A540
Series Model:	A54
Model Difference:	One is the market name and the other is the market model, There are 128GB and 256GB memory configurations
Frequency Bands:	U.S. Bands: LTE FDD Band 2 LTE FDD Band 4 LTE FDD Band 5 LTE FDD Band 7 LTE FDD Band 41
SIM Card:	SIM 1 and SIM 2 is a chipset unit and tested as single chipset, SIM 1 is used to tested.
Antenna:	FPC
Antenna gain:	LTE B2: 0.64dBi, LTE B4: -0.7dBi, LTE B5: -1.74dBi, LTE B7: -3.62dBi, LTE B41: 0.32dBi
Adapter:	Input: 100-240V~50/60Hz 0.35A Output: 5V, 2A
Battery:	Capacity: 4900mAh Rated Voltage: 3.85V
Extreme Vol. Limits:	3.5V to 4.4V (Nominal 3.85V)
Extreme Temp. Tolerance:	-0°C to + 40°C
Hardware Version:	V1.0
Software Version:	INOI_A540_EEA_T_V09_20240116_user

Note: The antenna information refer the manufacturer provide report, applicable only to the tested sample identified in the report.

2.1.2 PRODUCT SPECIFICATION SUBJECTIVE TO THIS STANDARD

Product Specification Subjective To This Standard	
Tx Frequency	LTE Band 2:1850~1910MHz LTE Band 4:1710~1755MHz LTE Band 5: 824~849MHz LTE Band 7:2500~2570MHz LTE Band 41: 2496-2690MHz
Rx Frequency	LTE Band 2: 1930-1990MHz LTE Band 4: 2110-2155MHz LTE Band 5: 869-894MHz LTE Band 7: 2620-2690MHz LTE Band 41: 2496-2690MHz
Bandwidth	LTE Band 2: 1.4MHz / 3MHz / 5MHz / 10MHz / 15MHz / 20MHz LTE Band 4: 1.4MHz / 3MHz / 5MHz / 10MHz / 15MHz /20MHz LTE Band 5: 1.4MHz / 3MHz / 5MHz / 10MHz LTE Band 7: 1.4MHz / 3MHz / 5MHz / 10MHz LTE Band 41: 5MHz / 10MHz / 15MHz /20MHz
Type of Modulation	QPSK /16QAM

2.1.3 TEST CONFIGURATION OF EQUIPMENT UNDER TEST

Antenna port conducted and radiated test items listed below are performed according to KDB 971168 D01 v03r01 and ANSI C63.26 2015 Power Meas. License Digital Systems with maximum output power. Radiated measurements are performed by rotating the EUT in three different orthogonal test planes to find the maximum emission.

Remark:

1. The mark 'v' means that this configuration is chosen for testing
2. The mark '-' means that this bandwidth is not supported.
3. The device is investigated from 30MHz to 10 times of fundamental signal for radiated.

ITEMS	Band	Bandwidth (MHz)						Modulation		RB #			Test Channel		
		1.4	3	5	10	15	20	QPSK	16QAM	1	Half	Full	L	M	H
E.R.P.& E.I.R.P.	2	v	v	v	v	v	v	v	v	v	v	v	v	v	v
	4	v	v	v	v	v	v	v	v	v	v	v	v	v	v
	5	v	v	v	v			v	v	v	v	v	v	v	v
	7			v	v	v	v	v	v	v	v	v	v	v	v
	41			v	v	v	v	v	v	v	v	v	v	v	v
Peak&Avera Ratio	2	v	v	v	v	v	v	v	v	v			v	v	v
	4	v	v	v	v	v	v	v	v	v			v	v	v
	5	v	v	v	v			v	v	v			v	v	v
	7			v	v	v	v	v	v	v			v	v	v
	41			v	v	v	v	v	v	v			v	v	v
26dB&99% Bandwidth	2	v	v	v	v	v	v	v	v			v	v	v	v
	4	v	v	v	v	v	v	v	v			v	v	v	v
	5	v	v	v	v			v	v			v	v	v	v
	7			v	v	v	v	v	v			v	v	v	v
	41			v	v	v	v	v	v			v	v	v	v
Conducted Band Edge	2	v	v	v	v	v	v	v	v	v			v	v	v
	4	v	v	v	v	v	v	v	v	v			v	v	v
	5	v	v	v	v			v	v	v			v	v	v
	7			v	v	v	v	v	v	v			v	v	v
	41			v	v	v	v	v	v	v			v	v	v
Conducted Spurious Emission	2	v	v	v	v	v	v	v	v				v	v	v
	4	v	v	v	v	v	v	v	v				v	v	v
	5	v	v	v	v			v	v				v	v	v
	7			v	v	v	v	v	v				v	v	v
	41			v	v	v	v	v	v				v	v	v
Frequency Stability	2						v	v	v				v		
	4						v	v	v				v		
	5				v			v	v				v		
	7						v	v	v				v		
	41						v	v	v				v		
Radiated Spurious Emission	2						v	v		v			v	v	v
	4						v	v		v			v	v	v
	5				v			v		v			v	v	v
	7						v	v		v			v	v	v
	41						v	v		v			v	v	v



#### 2.1.4 RELATED SUBMITTAL(S) / GRANT (S)

This submittal(s) (test report) is intended for filing to comply with the 47 CFR Part 2, 22, 24, 27.

#### 2.1.5 SPECIAL ACCESSORIES

The battery and the charger, earphone supplied by the applicant were used as accessories and being tested with eut intended for fcc grant together.

#### 2.1.6 EUT CONFIGURATION

The EUT configuration for testing is installed on RF field strength measurement to meet the Commission's requirement and operating in a manner which intends to maximize its emission characteristics in a continuous normal application.

#### 2.1.7 EUT EXERCISE

The Transmitter was operated in the maximum output power mode through Communication Tester. The TX frequency was fixed which was for the purpose of the measurements.

### 2.1.8 CONFIGURATION OF EUT SYSTEM

The EUT configuration for testing is installed on RF field strength measurement to meet the Commission's requirement and operating in a manner which intends to maximize its emission characteristics in a continuous normal application.



Table 2-1 Equipment Used in EUT System

Item	Equipment	Model No.	Length	Note
N/A				N/A

**Note:**

- (1) For detachable type I/O cable should be specified the length in cm in 『Length』 column.
- (2) “YES” is means “with core”; “NO” is means “without core”.

## 2.1.9 MEASUREMENT INSTRUMENTS

The radiated emission testing was performed according to the procedures of ANSI C63.26 2015 and FCC CFR 47 rules of 2.1046, 2.1047, 2.1049, 2.1051, 2.1053, 2.1055, 2.1057.

<b>RF Radiated Test equipment</b>					
<b>Equipment</b>	<b>Manufacturer</b>	<b>Model No.</b>	<b>Serial No.</b>	<b>Cal. Date</b>	<b>Cal. Until</b>
EMI Test Receiver	R&S	ESU8	100372	2024.03.09	2025.03.08
Active loop Antenna	ETS	6502	00049544	2023.10.13	2025.10.12
Spectrum Analyzer	Keysight	N9010B	MY60242508	2023.08.14	2024.08.13
Bilog Antenna	Schwarzbeck	VULB 9168	01447	2022.12.12	2025.12.11
Horn Antenna	Schwarzbeck	3115	10SL0060	2022.06.02	2025.06.01
Pre-amplifier (9kHz-1GHz)	EMtrace	RP01A	02017	2024.03.09	2025.03.08
Pre-amplifier (1-26.5G)	Agilent	8449B	3008A4722	2024.03.09	2025.03.08
Temperature & Humidity	JINGCHUANG	BT-3	N.A	2024.03.11	2025.03.10
Testing Software	EMC-I_V1.4.0.3_SKET				

<b>RF Conducted Test equipment</b>					
<b>Equipment</b>	<b>Manufacturer</b>	<b>Model No.</b>	<b>Serial No.</b>	<b>Cal. Date</b>	<b>Cal. Until</b>
Signal Analyzer	Keysight	N9010B	MY60242508	2023.08.14	2024.08.13
Signal Analyzer	Keysight	N9020A	MY50530994	2024.03.09	2025.03.08
RF Automatic Test system	MW	MW100-RFCB	MW220322LG-033	2024.03.09	2025.03.08
MXG Vector Signal Generator	Keysight	N5182B	MY59100717	2024.03.09	2025.03.08
Temperature& Humidity test chamber	AISRY	LX-1000L	171200018	2024.03.09	2025.03.08
Attenuator	eastsheep	90db	N.A	2024.03.09	2025.03.08
Temperature & Humidity	JINGCHUANG	BT-3	N.A	2024.03.11	2025.03.10
Digital multimeter	MASTECH	MS8261	MBGBC83053	2024.03.09	2025.03.08
Testing Software	MTS8310_V2.0.0.0_MW				

### 3. CONDUCTED OUTPUT POWER

#### 3.1 DESCRIPTION OF THE CONDUCTED OUTPUT POWER MEASUREMENT

##### 3.1.1 MEASUREMENT METHOD

A system simulator was used to establish communication with the eut. Its parameters were set to force the eut transmitting at maximum output power. The measured power in the radio frequency on the transmitter output terminals shall be reported.

Configuration follows KDB 971168 D01 v03r01.

##### 3.1.2 TEST SETUP



##### 3.1.3 TEST PROCEDURES

1. The transmitter output port was connected to system simulator.
2. Set EUT at maximum power through the system simulator.
3. Select lowest/middle/highest channels for each band and different modulation.
4. Measure and record the power level from the system simulator.

##### 3.1.4 TEST RESULTS

Note: Test chart See Appendix I

## 4. PEAK-TO-AVERAGE RATIO

### 4.1 DESCRIPTION OF THE CONDUCTED OUTPUT POWER MEASUREMENT

#### 4.1.1 MEASUREMENT METHOD

Use one of the procedures presented in 4.1.3 to measure the total peak power and record as PPk. Use one of the applicable procedures presented 4.1.3 to measure the total average power and record as PAvg. Both the peak and average power levels must be expressed in the same logarithmic units (e.g., dBm). Determine the PAPR from:

$$\text{PAPR (dB)} = \text{PPk (dBm)} - \text{PAvg (dBm)}.$$

#### 4.1.2 TEST SETUP

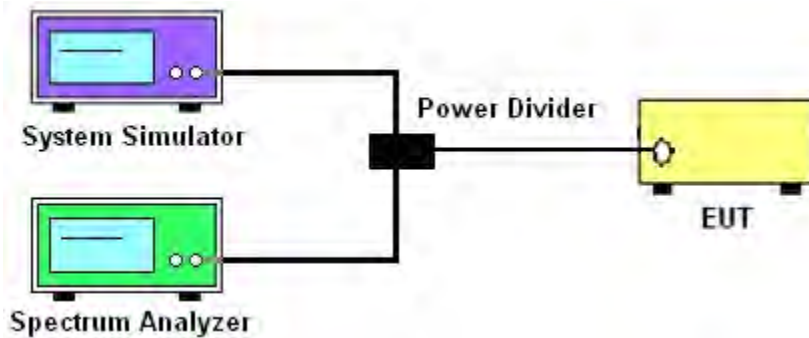

#### 4.1.3 TEST PROCEDURES

1. The testing follows FCC KDB 971168 D01 v03r01 Section 5.7 and ANSI C63.26 2015 Section 5.2.6.
2. The EUT was connected to spectrum and system simulator via a power divider
3. Select lowest, middle, and highest channels for each band and different modulation.
4. Set the test probe and measure the peak and average power of the spectrum analyzer
5. Record the deviation as Peak to Average Ratio.

	LTE					
LTE BW	1.4M	3M	5M	10M	15M	20M
Span	3MHz	6MHz	10MHz	20MHz	30MHz	40MHz
RBW	30kHz	30kHz	100kHz	100kHz	300kHz	300kHz
VBW	100kHz	100kHz	300kHz	300kHz	1000kHz	1000kHz
Detector	PK/AVG	PK/AVG	PK/AVG	PK/AVG	PK/AVG	PK/AVG
Trace	Max	Max	Max	Max	Max	Max
Sweep Count	Auto	Auto	Auto	Auto	Auto	Auto

#### 4.1.4 TEST RESULTS

Note: Test chart See Appendix I

## 5. RADIATED POWER AND EFFECTIVE ISOTROPIC RADIATED POWER

### 5.1 DESCRIPTION OF THE ERP/EIRP MEASUREMENT

#### 5.1.1 MEASUREMENT METHOD

Effective radiated power output measurements by substitution method according to ANSI C63.26 2015, and the spectrum analyzer configuration follows KDB 971168 D01 Power Meas. License Digital Systems. Mobile and portable (hand-held) stations operating are limited to average ERP, Equivalent isotropic radiated power output measurements by substitution method according to ANSI C63.26 2015, and the spectrum analyzer configuration follows KDB 971168 D01 Power Meas, Mobile and portable (hand-held) stations operating are limited to average EIRP.

#### 5.1.2 TEST SETUP

The procedure of radiated spurious emissions is as follows:

a) Pre-calibration With pre-calibration method, the Radiated Spurious Emissions(RSE) is calculated as,  $RSE = R_x \text{ (dBuV)} + CL \text{ (dB)} + SA \text{ (dB)} + Gain \text{ (dBi)} - 107 \text{ (dBuV to dBm)}$  The SA is calibrated using following setup.

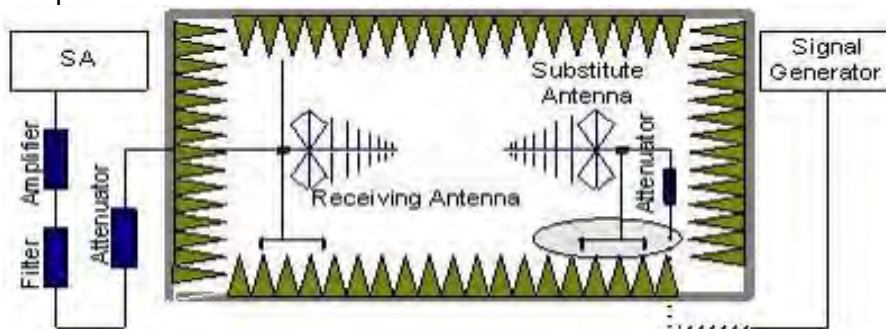

b) EUT was placed on a 1.5m non-conductive stand at a 3 m test distance from the receive antenna. A receiving antenna was placed on the antenna mast 3 m from the test item for emission measurements. The height of receiving antenna is 0.8m. The test setup refers to figure below. Detected emissions were maximized at each frequency by rotating the test item and adjusting the receiving antenna polarization. The radiated emission measurements of all non-harmonic and harmonics of the transmit frequency through the 10th harmonic measured with peak detector and 1MHz bandwidth.

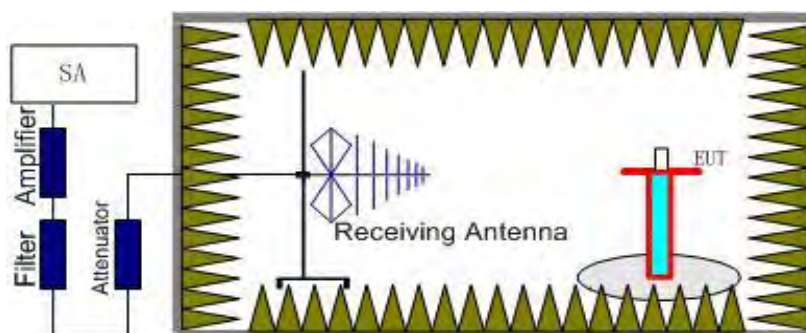

Radiated emissions measurements were made only at the upper, middle, and lower carrier frequencies. It was decided that measurements at these three carrier frequencies would be sufficient to demonstrate compliance with emissions limits because it was seen that all the significant spurs occur well outside the band and no radiation was seen from a carrier in one block of any band into any of the other blocks.

The substitution method is used. Substitution values at each frequency are measured before and saved to the test software. A "reference path loss" is established and the ARpl is the attenuation of "reference path loss", and including the gain of receive antenna, the gain of the preamplifier, the cable loss and the air loss. The measurement results are obtained as described below:

Power = P<sub>Mea</sub> + AR<sub>pl</sub>

### 5.1.3 TEST PROCEDURES

1. The testing follows FCC KDB 971168 D01v03r01 Section 5.6 and ANSI C63.26 2015 Section 5.2.
2. The EUT was placed on a non-conductive rotating platform 1.5 meters high in a semi-anechoic chamber. The radiated emission at the fundamental frequency was measured at 3 m with a test antenna and a spectrum analyzer with Peak detector.
3. During the measurement, the system simulator parameters were set to force the EUT transmitting at maximum output power. The maximum emission was recorded from analyzer power level (LVL) from the 360 degrees rotation of the turntable and the test antenna raised and lowered over a range from 1 to 4 m in both horizontally and vertically polarized orientations.
4. Effective Isotropic Radiated Power (EIRP) was measured by substitution method according to ANSI C63.26 2015. The EUT was replaced by dipole antenna (substitution antenna) at same location and then a known power from S.G. was applied into the dipole antenna through a Tx cable, and then recorded the maximum Analyzer reading through raised and lowered the test antenna.  $EIRP = S.G \text{ Level} + \text{Gain} - \text{Cable loss}$ ;  $ERP = S.G \text{ Level} + \text{Gain} - \text{Cable loss} - 2.15$ .
5. RB Set greater than bandwidth, VB Set spectrum analyzer Maximum support.

### 5.1.4 TEST RESULTS

Note: Test is divided into three directions, X/Y/Z. X pattern for the worst.

Note: Test chart See Appendix I

## 6. OCCUPIED BANDWIDTH

### 6.1 DESCRIPTION OF OCCUPIED BANDWIDTH MEASUREMENT

#### 6.1.1 MEASUREMENT METHOD

1. The occupied bandwidth is the width of a frequency band such that, below the lower and above the upper frequency limits, the mean powers emitted are each equal to a specified percentage 0.5% of the total mean transmitted power.

2. The 26 db emission bandwidth is defined as the frequency range between two points, one above and one below the carrier frequency, at which the spectral density of the emission is attenuated 26 db below the maximum in-band spectral density of the modulated signal. spectral density (power per unit bandwidth) is to be measured with a detector of resolution bandwidth equal to approximately 1.0% of the emission bandwidth.

#### 6.1.2 TEST SETUP

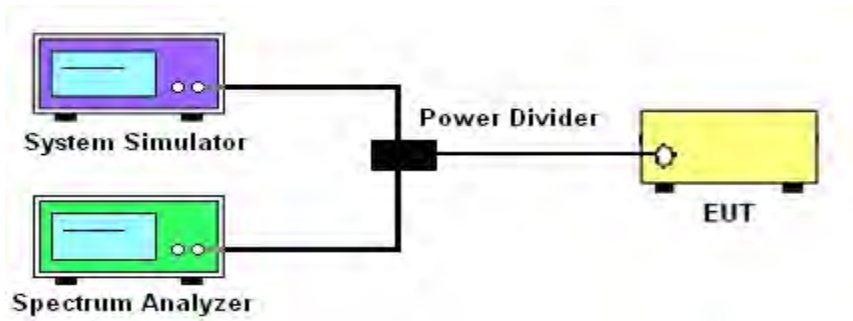

#### 6.1.3 TEST PROCEDURES

1. The testing follows FCC KDB 971168 D01 v03r01 Section 4.2 and 4.3.
2. The EUT was connected to spectrum and system simulator via a power divider.
3. Select lowest, middle, and highest channels for each band and different modulation.
4. Set the test probe and measure the Occupied Bandwidth of the spectrum analyzer.
5. Measure and record the Occupied Bandwidth from the Spectrum Analyzer.

	LTE					
LTE BW	1.4M	3M	5M	10M	15M	20M
Span	3MHz	6MHz	10MHz	20MHz	30MHz	40MHz
RBW	30kHz	30kHz	100kHz	100kHz	300kHz	300kHz
VBW	100kHz	100kHz	300kHz	300kHz	1000kHz	1000kHz
Detector	PK	PK	PK	PK	PK	PK
Trace	Max	Max	Max	Max	Max	Max
Sweep Count	Auto	Auto	Auto	Auto	Auto	Auto

#### 6.1.4 MEASUREMENT RESULT

Note: Test chart See Appendix I



## 7. CONDUCTED BAND EDGE

### 7.1 DESCRIPTION OF CONDUCTED BAND EDGE MEASUREMENT

#### 7.1.1 MEASUREMENT METHOD

##### 1. §22.917(a)

For operations in the 824 – 849 MHz band, the FCC limit is  $43 + 10\log_{10}(P[\text{Watts}])$  dB below the transmitter power  $P(\text{Watts})$  in a 100kHz bandwidth. However, in the 1MHz bands immediately outside and adjacent to the licensee's frequency block, a resolution bandwidth of at least one percent of the emission bandwidth of the fundamental emission of the transmitter may be employed.

##### 2. §24.238 (a)

For operations in the 1850-1910 and 1930-1990 MHz band, the FCC limit is  $43 + 10\log_{10}(P[\text{Watts}])$  dB below the transmitter power  $P(\text{Watts})$  in a 1MHz bandwidth. However, in the 1 MHz bands immediately outside and adjacent to the frequency block a resolution bandwidth of at least one percent of the emission bandwidth of the fundamental emission of the transmitter may be employed

##### 3. §27.53 (h)

For operations in the 1710 – 1755 MHz band, the FCC limit is  $43 + 10\log_{10}(P[\text{Watts}])$  dB below the transmitter power  $P(\text{Watts})$  in a 1 MHz bandwidth. However, in the 1MHz bands immediately outside and adjacent to the licensee's frequency block, a resolution bandwidth of at least one percent of the emission bandwidth of the fundamental emission of the transmitter may be employed.

##### 4. §27.53(m)(4)

For operations in the 2500 MHz ~ 2570 MHz band this section, the attenuation factor shall be not less than  $40 + 10 \log (P)$  dB on all frequencies between the channel edge and 5 megahertz from the channel edge,  $43 + 10 \log (P)$  dB on all frequencies between 5 megahertz and X megahertz from the channel edge, and  $55 + 10 \log (P)$  dB on all frequencies more than X megahertz from the channel edge, where X is the greater of 6 megahertz or the actual emission bandwidth as defined in paragraph (m)(6) of this section. In addition, the attenuation factor shall not be less that  $43 + 10 \log (P)$  dB on all frequencies between 2490.5 MHz and 2496 MHz and  $55 + 10 \log (P)$  dB at or below 2490.5 MHz. Mobile Satellite Service licensees operating on frequencies below 2495 MHz may also submit a documented interference complaint against BRS licensees operating on channel BRS Channel 1 on the same terms and conditions as adjacent channel BRS or EBS licensees.

##### 5. §27.53 (g)

For operations in the 698 -746 MHz band, the FCC limit is  $43 + 10\log_{10}(P[\text{Watts}])$  dB below the transmitter power  $P(\text{Watts})$  in a 100 kHz bandwidth. However, in the 100 kilohertz bands immediately outside and adjacent to a licensee's frequency block, a resolution bandwidth of at least 30 kHz may be employed.

### 7.1.2 TEST SETUP

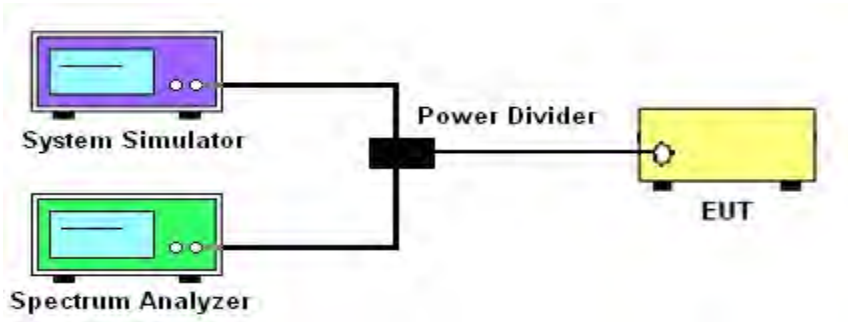

### 7.1.3 TEST PROCEDURES

1. The testing FCC KDB 971168 D01 v03r01 Section 6.0 and ANSI C63.26 2015 Section 5.7.
2. The EUT was connected to spectrum analyzer and system simulator via a power divider.
3. The band edges of low and high channels for the highest RF powers were measured. Set RBW  $\geq$  1% EBW in the 1MHz band immediately outside and adjacent to the band edge.
4. Set spectrum analyzer with RMS/AVG detector.
5. The RF fundamental frequency should be excluded against the limit line in the operating frequency band.
6. The limit line is derived from  $43 + 10\log(P)$  dB below the transmitter power P(Watts)
  - =  $P(W) - [43 + 10\log(P)]$  (dB)
  - =  $[30 + 10\log(P)]$  (dBm) -  $[43 + 10\log(P)]$  (dB)
  - = -13dBm.

Band 7:

- =  $P(W) - [55 + 10\log(P)]$  (dB)
- =  $[30 + 10\log(P)]$  (dBm) -  $[55 + 10\log(P)]$  (dB)
- = -25dBm.

	LTE					
LTE BW	1.4M	3M	5M	10M	15M	20M
Span	12MHz	13MHz	15MHz	20MHz	25MHz	30MHz
RBW	30kHz	30kHz	100kHz	100kHz	300kHz	300kHz
VBW	100kHz	100kHz	300kHz	300kHz	1000kHz	1000kHz
Detector	RMS	RMS	RMS	RMS	RMS	RMS
Trace	Max	Max	Max	Max	Max	Max
Sweep Count	Auto	Auto	Auto	Auto	Auto	Auto

### 7.1.4 MEASUREMENT RESULT

Note: Test chart See Appendix I

## 8. CONDUCTED SPURIOUS EMISSION

### 8.1 DESCRIPTION OF CONDUCTED SPURIOUS EMISSION MEASUREMENT

#### 8.1.1 MEASUREMENT METHOD

The power of any emission outside of the authorized operating frequency ranges must be lower than the transmitter power (P) by a factor of at least  $43 + 10 \log (P)$  dB.

For Band 7:

The power of any emission outside of the authorized operating frequency ranges must be lower than the transmitter power (P) by a factor of at least  $55 + 10 \log (P)$  dB.

It is measured by means of a calibrated spectrum analyzer and scanned from 30 MHz up to a frequency including its 10th harmonic.

#### 8.1.2 TEST SETUP

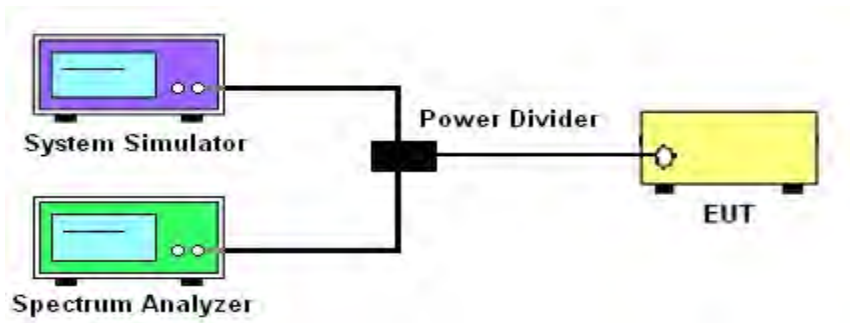

#### 8.1.3 TEST PROCEDURES

1. The testing FCC KDB 971168 D01 v03r01 Section 6.0 and ANSI C63.26 2015 Section 5.7.
2. The EUT was connected to spectrum analyzer and system simulator via a power divider.
3. The RF output of EUT was connected to the spectrum analyzer by RF cable and attenuator. The path loss was compensated to the results for each measurement
4. Make the measurement with the spectrum analyzer's RBW = 1MHz, VBW = 3MHz, taking the record of maximum spurious emission.
5. The RF fundamental frequency should be excluded against the limit line in the operating frequency band.
6. The limit line is derived from  $43 + 10\log(P)$  dB below the transmitter power P(Watts)  
 $= P(W) - [43 + 10\log(P)]$  (dB) =  $[30 + 10\log(P)]$  (dBm) -  $[43 + 10\log(P)]$  (dB)  
 $= -13$  dBm.

For Band 7:  $P(W) - [43 + 10\log(P)]$  (dB) = -25 dBm

	LTE					
LTE BW	1.4M	3M	5M	10M	15M	20M
Span	Auto	Auto	Auto	Auto	Auto	Auto
RBW	1000kHz	1000kHz	1000kHz	1000kHz	1000kHz	1000kHz
VBW	3000kHz	3000kHz	3000kHz	3000kHz	3000kHz	3000kHz
Detector	PK	PK	PK	PK	PK	PK
Trace	Max	Max	Max	Max	Max	Max

#### 8.1.4 TEST RESULTS

Note: Test chart See Appendix I

## 9. RADIATED SPURIOUS EMISSION

### 9.1 DESCRIPTION OF RADIATED SPURIOUS EMISSION

#### 9.1.1 MEASUREMENT METHOD

The radiated spurious emission was measured by substitution method according to ANSI C63.26 2015. The power of any emission outside of the authorized operating frequency ranges must be attenuated below the transmitter power (P) by a factor of at least  $43 + 10 \log (P)$  dB.

For Band 7 The power of any emission outside of the authorized operating frequency ranges must be attenuated below the transmitter power (P) by a factor of at least  $55 + 10 \log (P)$  dB. The spectrum is scanned from 30 MHz up to a frequency including its 10th harmonic.

#### 9.1.2 TEST SETUP

The procedure of radiated spurious emissions is as follows:

a) Pre-calibration With pre-calibration method, the Radiated Spurious Emissions(RSE) is calculated as,  $RSE = Rx(\text{dBuV}) + CL(\text{dB}) + SA(\text{dB}) + Gain(\text{dBi}) - 107(\text{dBuV to dBm})$  The SA is calibrated using following setup.

b) EUT was placed on 1.5 m non-conductive stand at a 3 m test distance from the receive antenna. A receiving antenna was placed on the antenna mast 3 m from the test item for emission measurements. The height of receiving antenna is 0.8m. The test setup refers to figure below. Detected emissions were maximized at each frequency by rotating the test item and adjusting the receiving antenna polarization. The radiated emission measurements of all non-harmonic and harmonics of the transmit frequency through the 10th harmonic measured with peak detector and 1MHz bandwidth. Radiated emissions measurements were made only at the upper, middle, and lower carrier frequencies It was decided that measurements at these three carrier frequencies would be sufficient to demonstrate compliance with emissions limits because it was seen that all the significant spurs occur well outside the band and no radiation was seen from a carrier in one block of any band into any of the other blocks.

The substitution method is used. Substitution values at each frequency are measured before and saved to the test software. A "reference path loss" is established and the ARpl is the attenuation of "reference path loss", and including the gain of receive antenna, the gain of the preamplifier, the cable loss and the air loss. The measurement results are obtained as described below:  $Power = P_{Mea} + AR_{pl}$  For radiated test from 30MHz to 1GHz

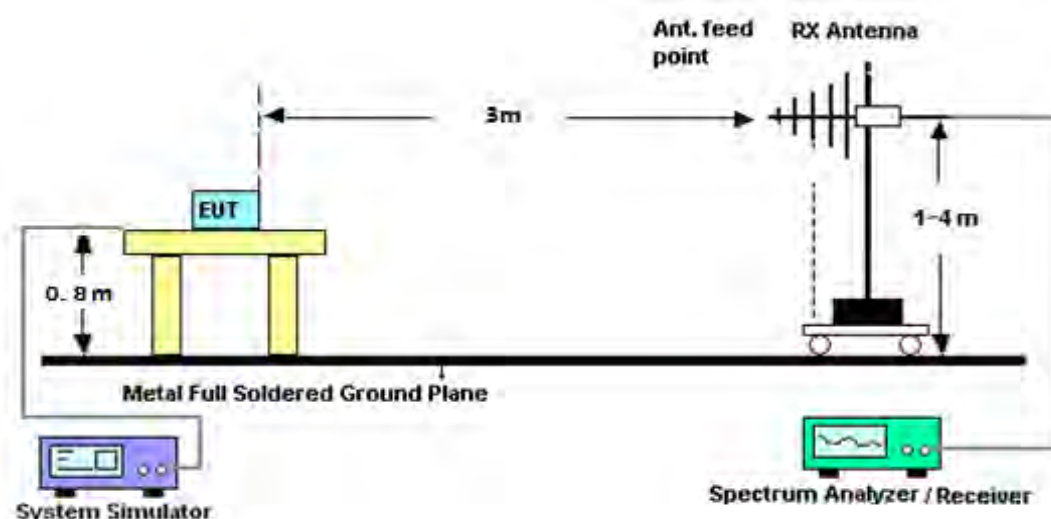

For radiated test from above 1GHz

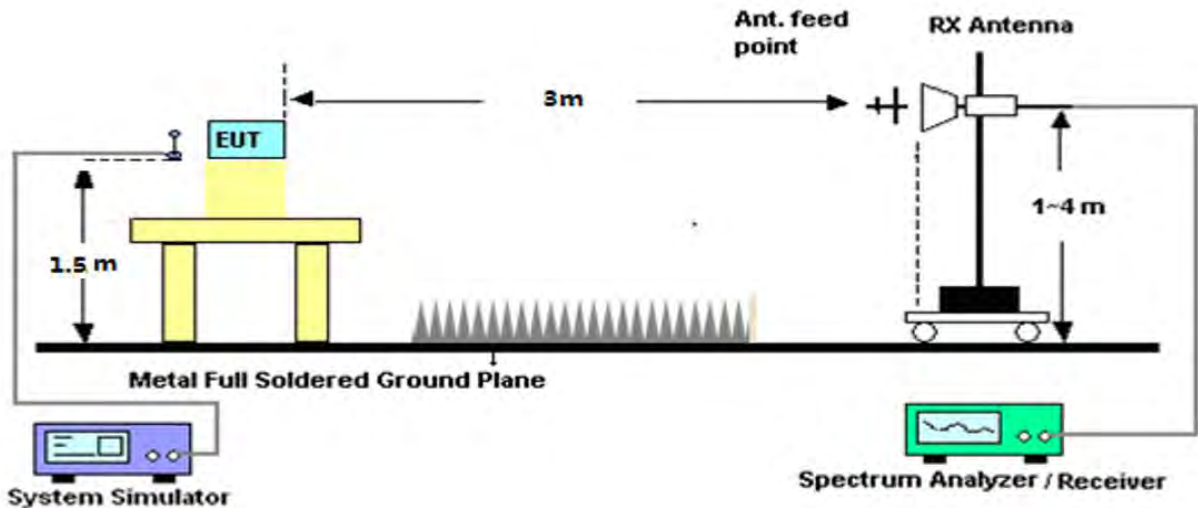

### 9.1.3 TEST PROCEDURES

1. The testing FCC KDB 971168 D01 Section 7 and ANSI C63.26 2015 Section 5.5.
2. The EUT was placed on a rotatable wooden table with 1.5 meter above ground.
3. The EUT was set 3 meters from the receiving antenna, which was mounted on the antenna tower.
4. The table was rotated 360 degrees to determine the position of the highest spurious emission.
5. The height of the receiving antenna is varied between one meter and four meters to search the maximum spurious emission for both horizontal and vertical polarizations
6. Make the measurement with the spectrum analyzer's RBW = 1MHz, VBW = 3MHz, taking the record of maximum spurious emission.
7. A horn antenna was substituted in place of the EUT and was driven by a signal generator.
8. Tune the output power of signal generator to the same emission level with EUT maximum spurious emission.
9. Taking the record of output power at antenna port.
10. Repeat step 7 to step 8 for another polarization.
11. The RF fundamental frequency should be excluded against the limit line in the operating frequency band.

The limit line is derived from  $43 + 10\log(P)$ dB below the transmitter power P(Watts)  
 $= P(W) - [43 + 10\log(P)]$  (dB)  
 $= [30 + 10\log(P)]$  (dBm) -  $[43 + 10\log(P)]$  (dB)  
 $= -13$ dBm

For Band 7:

The limit line is derived from  $55 + 10\log(P)$ dB below the transmitter power P(Watts)  
 $= [30 + 10\log(P)]$  (dBm) -  $[55 + 10\log(P)]$  (dB)  
 $= -25$ dBm

$P_{Mea} = S.G \text{ Level} + \text{Ant-Cable loss}$ ;  $\text{Margin} = P_{Mea} - \text{Limit}$ .

### 9.1.4 TEST RESULTS

Note: Test chart See Appendix I

## 10. FREQUENCY STABILITY

### 10.1 DESCRIPTION OF FREQUENCY STABILITY MEASUREMENT

#### 10.1.1 MEASUREMENT METHOD

The frequency stability shall be measured by variation of ambient temperature and variation of primary supply voltage to ensure that the fundamental emission stays within the authorized frequency block. The frequency stability of the transmitter shall be maintained within  $\pm 0.00025\%$  ( $\pm 2.5\text{ppm}$ ) of the center frequency.

#### 10.1.2 TEST SETUP

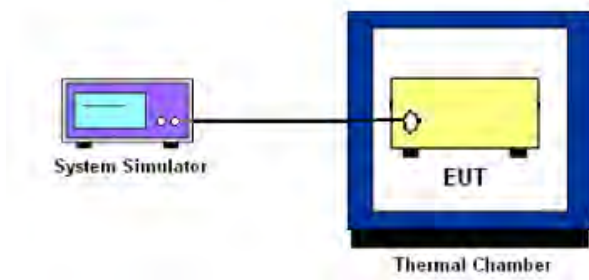

#### 10.1.3 TEST PROCEDURES FOR TEMPERATURE VARIATION

1. The EUT was set up in the thermal chamber and connected with the system simulator.
2. With power OFF, the temperature was decreased to  $-30^{\circ}\text{C}$  and the EUT was stabilized before testing. Power was applied and the maximum change in frequency was recorded within one minute.
3. With power OFF, the temperature was raised in  $10^{\circ}\text{C}$  step up to  $50^{\circ}\text{C}$ . The EUT was stabilized at each step for at least half an hour. Power was applied and the maximum frequency change was recorded within one minute.

#### 10.1.4 TEST PROCEDURES FOR VOLTAGE VARIATION

1. The testing follows FCC KDB 971168 D01v01r03 Section 9.
2. The EUT was placed in a temperature chamber at  $25\pm 5^{\circ}\text{C}$  and connected with the system simulator.
3. The power supply voltage to the EUT was varied from 85% to 115% of the nominal value measured at the input to the EUT.
4. The variation in frequency was measured for the worst case.

#### 10.1.5 TEST RESULTS

Note: Test chart See Appendix I

## APPENDIX I - TEST DATA

Conducted output power

Band	Bandwidth (MHz)	UL Channel	RB Size	RB Position	Modulation	Power (dBm)	Gain (dB)	EIRP (dBm)	EIRP Limit (dBm)	Verdict
Band2	1.4	18607	1	#0	QPSK	21.62	0.64	22.26	33.01	PASS
Band2	1.4	18607	1	#Mid	QPSK	21.78	0.64	22.42	33.01	PASS
Band2	1.4	18607	1	#Max	QPSK	21.66	0.64	22.30	33.01	PASS
Band2	1.4	18607	3	#0	QPSK	21.70	0.64	22.34	33.01	PASS
Band2	1.4	18607	3	#Mid	QPSK	21.69	0.64	22.33	33.01	PASS
Band2	1.4	18607	3	#Max	QPSK	21.69	0.64	22.33	33.01	PASS
Band2	1.4	18607	6	#0	QPSK	21.67	0.64	22.31	33.01	PASS
Band2	1.4	18607	1	#0	16QAM	21.52	0.64	22.16	33.01	PASS
Band2	1.4	18607	1	#Mid	16QAM	21.69	0.64	22.33	33.01	PASS
Band2	1.4	18607	1	#Max	16QAM	21.54	0.64	22.18	33.01	PASS
Band2	1.4	18607	3	#0	16QAM	21.79	0.64	22.43	33.01	PASS
Band2	1.4	18607	3	#Mid	16QAM	21.86	0.64	22.50	33.01	PASS
Band2	1.4	18607	3	#Max	16QAM	21.84	0.64	22.48	33.01	PASS
Band2	1.4	18607	6	#0	16QAM	21.37	0.64	22.01	33.01	PASS
Band2	1.4	18900	1	#0	QPSK	21.63	0.64	22.27	33.01	PASS
Band2	1.4	18900	1	#Mid	QPSK	21.78	0.64	22.42	33.01	PASS
Band2	1.4	18900	1	#Max	QPSK	21.62	0.64	22.26	33.01	PASS
Band2	1.4	18900	3	#0	QPSK	21.57	0.64	22.21	33.01	PASS
Band2	1.4	18900	3	#Mid	QPSK	21.61	0.64	22.25	33.01	PASS
Band2	1.4	18900	3	#Max	QPSK	21.62	0.64	22.26	33.01	PASS
Band2	1.4	18900	6	#0	QPSK	21.60	0.64	22.24	33.01	PASS
Band2	1.4	18900	1	#0	16QAM	21.79	0.64	22.43	33.01	PASS
Band2	1.4	18900	1	#Mid	16QAM	21.93	0.64	22.57	33.01	PASS
Band2	1.4	18900	1	#Max	16QAM	21.78	0.64	22.42	33.01	PASS
Band2	1.4	18900	3	#0	16QAM	21.81	0.64	22.45	33.01	PASS
Band2	1.4	18900	3	#Mid	16QAM	21.83	0.64	22.47	33.01	PASS
Band2	1.4	18900	3	#Max	16QAM	21.81	0.64	22.45	33.01	PASS
Band2	1.4	18900	6	#0	16QAM	21.31	0.64	21.95	33.01	PASS
Band2	1.4	19193	1	#0	QPSK	21.63	0.64	22.27	33.01	PASS
Band2	1.4	19193	1	#Mid	QPSK	21.81	0.64	22.45	33.01	PASS
Band2	1.4	19193	1	#Max	QPSK	21.65	0.64	22.29	33.01	PASS
Band2	1.4	19193	3	#0	QPSK	21.72	0.64	22.36	33.01	PASS
Band2	1.4	19193	3	#Mid	QPSK	21.74	0.64	22.38	33.01	PASS
Band2	1.4	19193	3	#Max	QPSK	21.76	0.64	22.40	33.01	PASS
Band2	1.4	19193	6	#0	QPSK	21.72	0.64	22.36	33.01	PASS
Band2	1.4	19193	1	#0	16QAM	21.88	0.64	22.52	33.01	PASS
Band2	1.4	19193	1	#Mid	16QAM	22.01	0.64	22.65	33.01	PASS
Band2	1.4	19193	1	#Max	16QAM	21.88	0.64	22.52	33.01	PASS
Band2	1.4	19193	3	#0	16QAM	21.95	0.64	22.59	33.01	PASS
Band2	1.4	19193	3	#Mid	16QAM	22.00	0.64	22.64	33.01	PASS
Band2	1.4	19193	3	#Max	16QAM	22.01	0.64	22.65	33.01	PASS
Band2	1.4	19193	6	#0	16QAM	21.46	0.64	22.10	33.01	PASS
Band2	3	18615	1	#0	QPSK	21.65	0.64	22.29	33.01	PASS
Band2	3	18615	1	#Mid	QPSK	22.00	0.64	22.64	33.01	PASS
Band2	3	18615	1	#Max	QPSK	21.67	0.64	22.31	33.01	PASS
Band2	3	18615	8	#0	QPSK	21.65	0.64	22.29	33.01	PASS
Band2	3	18615	8	#Mid	QPSK	21.65	0.64	22.29	33.01	PASS
Band2	3	18615	8	#Max	QPSK	21.66	0.64	22.30	33.01	PASS
Band2	3	18615	15	#0	QPSK	21.61	0.64	22.25	33.01	PASS
Band2	3	18615	1	#0	16QAM	22.11	0.64	22.75	33.01	PASS
Band2	3	18615	1	#Mid	16QAM	22.37	0.64	23.01	33.01	PASS
Band2	3	18615	1	#Max	16QAM	22.08	0.64	22.72	33.01	PASS
Band2	3	18615	8	#0	16QAM	21.24	0.64	21.88	33.01	PASS
Band2	3	18615	8	#Mid	16QAM	21.24	0.64	21.88	33.01	PASS
Band2	3	18615	8	#Max	16QAM	21.24	0.64	21.88	33.01	PASS
Band2	3	18615	15	#0	16QAM	21.19	0.64	21.83	33.01	PASS

Band2	3	18900	1	#0	QPSK	21.63	0.64	22.27	33.01	PASS
Band2	3	18900	1	#Mid	QPSK	21.81	0.64	22.45	33.01	PASS
Band2	3	18900	1	#Max	QPSK	21.60	0.64	22.24	33.01	PASS
Band2	3	18900	8	#0	QPSK	21.58	0.64	22.22	33.01	PASS
Band2	3	18900	8	#Mid	QPSK	21.57	0.64	22.21	33.01	PASS
Band2	3	18900	8	#Max	QPSK	21.57	0.64	22.21	33.01	PASS
Band2	3	18900	15	#0	QPSK	21.54	0.64	22.18	33.01	PASS
Band2	3	18900	1	#0	16QAM	21.88	0.64	22.52	33.01	PASS
Band2	3	18900	1	#Mid	16QAM	22.07	0.64	22.71	33.01	PASS
Band2	3	18900	1	#Max	16QAM	21.84	0.64	22.48	33.01	PASS
Band2	3	18900	8	#0	16QAM	21.20	0.64	21.84	33.01	PASS
Band2	3	18900	8	#Mid	16QAM	21.16	0.64	21.80	33.01	PASS
Band2	3	18900	8	#Max	16QAM	21.14	0.64	21.78	33.01	PASS
Band2	3	18900	15	#0	16QAM	21.09	0.64	21.73	33.01	PASS
Band2	3	19185	1	#0	QPSK	21.75	0.64	22.39	33.01	PASS
Band2	3	19185	1	#Mid	QPSK	22.12	0.64	22.76	33.01	PASS
Band2	3	19185	1	#Max	QPSK	21.80	0.64	22.44	33.01	PASS
Band2	3	19185	8	#0	QPSK	21.72	0.64	22.36	33.01	PASS
Band2	3	19185	8	#Mid	QPSK	21.75	0.64	22.39	33.01	PASS
Band2	3	19185	8	#Max	QPSK	21.72	0.64	22.36	33.01	PASS
Band2	3	19185	15	#0	QPSK	21.68	0.64	22.32	33.01	PASS
Band2	3	19185	1	#0	16QAM	21.67	0.64	22.31	33.01	PASS
Band2	3	19185	1	#Mid	16QAM	21.97	0.64	22.61	33.01	PASS
Band2	3	19185	1	#Max	16QAM	21.67	0.64	22.31	33.01	PASS
Band2	3	19185	8	#0	16QAM	21.30	0.64	21.94	33.01	PASS
Band2	3	19185	8	#Mid	16QAM	21.30	0.64	21.94	33.01	PASS
Band2	3	19185	8	#Max	16QAM	21.29	0.64	21.93	33.01	PASS
Band2	3	19185	15	#0	16QAM	21.36	0.64	22.00	33.01	PASS
Band2	5	18625	1	#0	QPSK	21.58	0.64	22.22	33.01	PASS
Band2	5	18625	1	#Mid	QPSK	21.99	0.64	22.63	33.01	PASS
Band2	5	18625	1	#Max	QPSK	21.61	0.64	22.25	33.01	PASS
Band2	5	18625	12	#0	QPSK	21.62	0.64	22.26	33.01	PASS
Band2	5	18625	12	#Mid	QPSK	21.70	0.64	22.34	33.01	PASS
Band2	5	18625	12	#Max	QPSK	21.64	0.64	22.28	33.01	PASS
Band2	5	18625	25	#0	QPSK	21.61	0.64	22.25	33.01	PASS
Band2	5	18625	1	#0	16QAM	22.18	0.64	22.82	33.01	PASS
Band2	5	18625	1	#Mid	16QAM	22.53	0.64	23.17	33.01	PASS
Band2	5	18625	1	#Max	16QAM	22.17	0.64	22.81	33.01	PASS
Band2	5	18625	12	#0	16QAM	21.16	0.64	21.80	33.01	PASS
Band2	5	18625	12	#Mid	16QAM	21.26	0.64	21.90	33.01	PASS
Band2	5	18625	12	#Max	16QAM	21.22	0.64	21.86	33.01	PASS
Band2	5	18625	25	#0	16QAM	21.19	0.64	21.83	33.01	PASS
Band2	5	18900	1	#0	QPSK	21.56	0.64	22.20	33.01	PASS
Band2	5	18900	1	#Mid	QPSK	21.92	0.64	22.56	33.01	PASS
Band2	5	18900	1	#Max	QPSK	21.55	0.64	22.19	33.01	PASS
Band2	5	18900	12	#0	QPSK	21.57	0.64	22.21	33.01	PASS
Band2	5	18900	12	#Mid	QPSK	21.66	0.64	22.30	33.01	PASS
Band2	5	18900	12	#Max	QPSK	21.57	0.64	22.21	33.01	PASS
Band2	5	18900	25	#0	QPSK	21.60	0.64	22.24	33.01	PASS
Band2	5	18900	1	#0	16QAM	21.93	0.64	22.57	33.01	PASS
Band2	5	18900	1	#Mid	16QAM	22.30	0.64	22.94	33.01	PASS
Band2	5	18900	1	#Max	16QAM	21.92	0.64	22.56	33.01	PASS
Band2	5	18900	12	#0	16QAM	21.11	0.64	21.75	33.01	PASS
Band2	5	18900	12	#Mid	16QAM	21.17	0.64	21.81	33.01	PASS
Band2	5	18900	12	#Max	16QAM	21.08	0.64	21.72	33.01	PASS
Band2	5	18900	25	#0	16QAM	21.23	0.64	21.87	33.01	PASS
Band2	5	19175	1	#0	QPSK	21.61	0.64	22.25	33.01	PASS
Band2	5	19175	1	#Mid	QPSK	21.98	0.64	22.62	33.01	PASS
Band2	5	19175	1	#Max	QPSK	21.63	0.64	22.27	33.01	PASS
Band2	5	19175	12	#0	QPSK	21.72	0.64	22.36	33.01	PASS
Band2	5	19175	12	#Mid	QPSK	21.83	0.64	22.47	33.01	PASS



Band2	5	19175	12	#Max	QPSK	21.74	0.64	22.38	33.01	PASS
Band2	5	19175	25	#0	QPSK	21.79	0.64	22.43	33.01	PASS
Band2	5	19175	1	#0	16QAM	22.01	0.64	22.65	33.01	PASS
Band2	5	19175	1	#Mid	16QAM	22.45	0.64	23.09	33.01	PASS
Band2	5	19175	1	#Max	16QAM	22.01	0.64	22.65	33.01	PASS
Band2	5	19175	12	#0	16QAM	21.33	0.64	21.97	33.01	PASS
Band2	5	19175	12	#Mid	16QAM	21.35	0.64	21.99	33.01	PASS
Band2	5	19175	12	#Max	16QAM	21.37	0.64	22.01	33.01	PASS
Band2	5	19175	25	#0	16QAM	21.34	0.64	21.98	33.01	PASS
Band2	10	18650	1	#0	QPSK	21.69	0.64	22.33	33.01	PASS
Band2	10	18650	1	#Mid	QPSK	21.85	0.64	22.49	33.01	PASS
Band2	10	18650	1	#Max	QPSK	21.74	0.64	22.38	33.01	PASS
Band2	10	18650	25	#0	QPSK	21.68	0.64	22.32	33.01	PASS
Band2	10	18650	25	#Mid	QPSK	21.75	0.64	22.39	33.01	PASS
Band2	10	18650	25	#Max	QPSK	21.78	0.64	22.42	33.01	PASS
Band2	10	18650	50	#0	QPSK	21.72	0.64	22.36	33.01	PASS
Band2	10	18650	1	#0	16QAM	21.86	0.64	22.50	33.01	PASS
Band2	10	18650	1	#Mid	16QAM	22.02	0.64	22.66	33.01	PASS
Band2	10	18650	1	#Max	16QAM	21.93	0.64	22.57	33.01	PASS
Band2	10	18650	25	#0	16QAM	21.23	0.64	21.87	33.01	PASS
Band2	10	18650	25	#Mid	16QAM	21.26	0.64	21.90	33.01	PASS
Band2	10	18650	25	#Max	16QAM	21.34	0.64	21.98	33.01	PASS
Band2	10	18650	50	#0	16QAM	21.31	0.64	21.95	33.01	PASS
Band2	10	18900	1	#0	QPSK	21.71	0.64	22.35	33.01	PASS
Band2	10	18900	1	#Mid	QPSK	21.85	0.64	22.49	33.01	PASS
Band2	10	18900	1	#Max	QPSK	21.76	0.64	22.40	33.01	PASS
Band2	10	18900	25	#0	QPSK	21.71	0.64	22.35	33.01	PASS
Band2	10	18900	25	#Mid	QPSK	21.69	0.64	22.33	33.01	PASS
Band2	10	18900	25	#Max	QPSK	21.69	0.64	22.33	33.01	PASS
Band2	10	18900	50	#0	QPSK	21.66	0.64	22.30	33.01	PASS
Band2	10	18900	1	#0	16QAM	21.59	0.64	22.23	33.01	PASS
Band2	10	18900	1	#Mid	16QAM	21.71	0.64	22.35	33.01	PASS
Band2	10	18900	1	#Max	16QAM	21.54	0.64	22.18	33.01	PASS
Band2	10	18900	25	#0	16QAM	21.34	0.64	21.98	33.01	PASS
Band2	10	18900	25	#Mid	16QAM	21.27	0.64	21.91	33.01	PASS
Band2	10	18900	25	#Max	16QAM	21.28	0.64	21.92	33.01	PASS
Band2	10	18900	50	#0	16QAM	21.31	0.64	21.95	33.01	PASS
Band2	10	19150	1	#0	QPSK	21.66	0.64	22.30	33.01	PASS
Band2	10	19150	1	#Mid	QPSK	21.86	0.64	22.50	33.01	PASS
Band2	10	19150	1	#Max	QPSK	21.73	0.64	22.37	33.01	PASS
Band2	10	19150	25	#0	QPSK	21.87	0.64	22.51	33.01	PASS
Band2	10	19150	25	#Mid	QPSK	21.83	0.64	22.47	33.01	PASS
Band2	10	19150	25	#Max	QPSK	21.88	0.64	22.52	33.01	PASS
Band2	10	19150	50	#0	QPSK	21.84	0.64	22.48	33.01	PASS
Band2	10	19150	1	#0	16QAM	22.11	0.64	22.75	33.01	PASS
Band2	10	19150	1	#Mid	16QAM	22.32	0.64	22.96	33.01	PASS
Band2	10	19150	1	#Max	16QAM	22.17	0.64	22.81	33.01	PASS
Band2	10	19150	25	#0	16QAM	21.48	0.64	22.12	33.01	PASS
Band2	10	19150	25	#Mid	16QAM	21.41	0.64	22.05	33.01	PASS
Band2	10	19150	25	#Max	16QAM	21.49	0.64	22.13	33.01	PASS
Band2	10	19150	50	#0	16QAM	21.47	0.64	22.11	33.01	PASS
Band2	15	18675	1	#0	QPSK	21.61	0.64	22.25	33.01	PASS
Band2	15	18675	1	#Mid	QPSK	22.04	0.64	22.68	33.01	PASS
Band2	15	18675	1	#Max	QPSK	21.59	0.64	22.23	33.01	PASS
Band2	15	18675	36	#0	QPSK	21.66	0.64	22.30	33.01	PASS
Band2	15	18675	36	#Mid	QPSK	21.77	0.64	22.41	33.01	PASS
Band2	15	18675	36	#Max	QPSK	21.76	0.64	22.40	33.01	PASS
Band2	15	18675	75	#0	QPSK	21.72	0.64	22.36	33.01	PASS
Band2	15	18675	1	#0	16QAM	21.68	0.64	22.32	33.01	PASS
Band2	15	18675	1	#Mid	16QAM	22.08	0.64	22.72	33.01	PASS
Band2	15	18675	1	#Max	16QAM	21.73	0.64	22.37	33.01	PASS

Band2	15	18675	36	#0	16QAM	21.16	0.64	21.80	33.01	PASS
Band2	15	18675	36	#Mid	16QAM	21.25	0.64	21.89	33.01	PASS
Band2	15	18675	36	#Max	16QAM	21.25	0.64	21.89	33.01	PASS
Band2	15	18675	75	#0	16QAM	21.25	0.64	21.89	33.01	PASS
Band2	15	18900	1	#0	QPSK	21.56	0.64	22.20	33.01	PASS
Band2	15	18900	1	#Mid	QPSK	21.90	0.64	22.54	33.01	PASS
Band2	15	18900	1	#Max	QPSK	21.47	0.64	22.11	33.01	PASS
Band2	15	18900	36	#0	QPSK	21.73	0.64	22.37	33.01	PASS
Band2	15	18900	36	#Mid	QPSK	21.67	0.64	22.31	33.01	PASS
Band2	15	18900	36	#Max	QPSK	21.62	0.64	22.26	33.01	PASS
Band2	15	18900	75	#0	QPSK	21.65	0.64	22.29	33.01	PASS
Band2	15	18900	1	#0	16QAM	22.03	0.64	22.67	33.01	PASS
Band2	15	18900	1	#Mid	16QAM	22.38	0.64	23.02	33.01	PASS
Band2	15	18900	1	#Max	16QAM	21.97	0.64	22.61	33.01	PASS
Band2	15	18900	36	#0	16QAM	21.28	0.64	21.92	33.01	PASS
Band2	15	18900	36	#Mid	16QAM	21.26	0.64	21.90	33.01	PASS
Band2	15	18900	36	#Max	16QAM	21.30	0.64	21.94	33.01	PASS
Band2	15	18900	75	#0	16QAM	21.23	0.64	21.87	33.01	PASS
Band2	15	19125	1	#0	QPSK	21.59	0.64	22.23	33.01	PASS
Band2	15	19125	1	#Mid	QPSK	21.92	0.64	22.56	33.01	PASS
Band2	15	19125	1	#Max	QPSK	21.69	0.64	22.33	33.01	PASS
Band2	15	19125	36	#0	QPSK	21.76	0.64	22.40	33.01	PASS
Band2	15	19125	36	#Mid	QPSK	21.74	0.64	22.38	33.01	PASS
Band2	15	19125	36	#Max	QPSK	21.81	0.64	22.45	33.01	PASS
Band2	15	19125	75	#0	QPSK	21.73	0.64	22.37	33.01	PASS
Band2	15	19125	1	#0	16QAM	21.74	0.64	22.38	33.01	PASS
Band2	15	19125	1	#Mid	16QAM	22.22	0.64	22.86	33.01	PASS
Band2	15	19125	1	#Max	16QAM	21.89	0.64	22.53	33.01	PASS
Band2	15	19125	36	#0	16QAM	21.34	0.64	21.98	33.01	PASS
Band2	15	19125	36	#Mid	16QAM	21.36	0.64	22.00	33.01	PASS
Band2	15	19125	36	#Max	16QAM	21.40	0.64	22.04	33.01	PASS
Band2	15	19125	75	#0	16QAM	21.36	0.64	22.00	33.01	PASS
Band2	20	18700	1	#0	QPSK	21.42	0.64	22.06	33.01	PASS
Band2	20	18700	1	#Mid	QPSK	21.84	0.64	22.48	33.01	PASS
Band2	20	18700	1	#Max	QPSK	21.51	0.64	22.15	33.01	PASS
Band2	20	18700	50	#0	QPSK	21.62	0.64	22.26	33.01	PASS
Band2	20	18700	50	#Mid	QPSK	21.71	0.64	22.35	33.01	PASS
Band2	20	18700	50	#Max	QPSK	21.73	0.64	22.37	33.01	PASS
Band2	20	18700	100	#0	QPSK	21.69	0.64	22.33	33.01	PASS
Band2	20	18700	1	#0	16QAM	21.70	0.64	22.34	33.01	PASS
Band2	20	18700	1	#Mid	16QAM	22.11	0.64	22.75	33.01	PASS
Band2	20	18700	1	#Max	16QAM	21.78	0.64	22.42	33.01	PASS
Band2	20	18700	50	#0	16QAM	21.27	0.64	21.91	33.01	PASS
Band2	20	18700	50	#Mid	16QAM	21.30	0.64	21.94	33.01	PASS
Band2	20	18700	50	#Max	16QAM	21.31	0.64	21.95	33.01	PASS
Band2	20	18700	100	#0	16QAM	21.28	0.64	21.92	33.01	PASS
Band2	20	18900	1	#0	QPSK	21.42	0.64	22.06	33.01	PASS
Band2	20	18900	1	#Mid	QPSK	21.73	0.64	22.37	33.01	PASS
Band2	20	18900	1	#Max	QPSK	21.32	0.64	21.96	33.01	PASS
Band2	20	18900	50	#0	QPSK	21.82	0.64	22.46	33.01	PASS
Band2	20	18900	50	#Mid	QPSK	21.68	0.64	22.32	33.01	PASS
Band2	20	18900	50	#Max	QPSK	21.70	0.64	22.34	33.01	PASS
Band2	20	18900	100	#0	QPSK	21.73	0.64	22.37	33.01	PASS
Band2	20	18900	1	#0	16QAM	21.77	0.64	22.41	33.01	PASS
Band2	20	18900	1	#Mid	16QAM	22.11	0.64	22.75	33.01	PASS
Band2	20	18900	1	#Max	16QAM	21.74	0.64	22.38	33.01	PASS
Band2	20	18900	50	#0	16QAM	21.43	0.64	22.07	33.01	PASS
Band2	20	18900	50	#Mid	16QAM	21.30	0.64	21.94	33.01	PASS
Band2	20	18900	50	#Max	16QAM	21.35	0.64	21.99	33.01	PASS
Band2	20	18900	100	#0	16QAM	21.32	0.64	21.96	33.01	PASS
Band2	20	19100	1	#0	QPSK	21.41	0.64	22.05	33.01	PASS

Band2	20	19100	1	#Mid	QPSK	21.89	0.64	22.53	33.01	PASS
Band2	20	19100	1	#Max	QPSK	21.62	0.64	22.26	33.01	PASS
Band2	20	19100	50	#0	QPSK	21.75	0.64	22.39	33.01	PASS
Band2	20	19100	50	#Mid	QPSK	21.73	0.64	22.37	33.01	PASS
Band2	20	19100	50	#Max	QPSK	21.70	0.64	22.34	33.01	PASS
Band2	20	19100	100	#0	QPSK	21.74	0.64	22.38	33.01	PASS
Band2	20	19100	1	#0	16QAM	21.65	0.64	22.29	33.01	PASS
Band2	20	19100	1	#Mid	16QAM	22.17	0.64	22.81	33.01	PASS
Band2	20	19100	1	#Max	16QAM	21.88	0.64	22.52	33.01	PASS
Band2	20	19100	50	#0	16QAM	21.32	0.64	21.96	33.01	PASS
Band2	20	19100	50	#Mid	16QAM	21.27	0.64	21.91	33.01	PASS
Band2	20	19100	50	#Max	16QAM	21.28	0.64	21.92	33.01	PASS
Band2	20	19100	100	#0	16QAM	21.26	0.64	21.90	33.01	PASS

Band	Bandwidth (MHz)	UL Channel	RB Size	RB Position	Modulation	Power (dBm)	Gain (dB)	EIRP (dBm)	EIRP Limit (dBm)	Verdict
Band4	1.4	19957	1	#0	QPSK	21.81	-0.7	21.11	30	PASS
Band4	1.4	19957	1	#Mid	QPSK	21.94	-0.7	21.24	30	PASS
Band4	1.4	19957	1	#Max	QPSK	21.74	-0.7	21.04	30	PASS
Band4	1.4	19957	3	#0	QPSK	21.86	-0.7	21.16	30	PASS
Band4	1.4	19957	3	#Mid	QPSK	21.86	-0.7	21.16	30	PASS
Band4	1.4	19957	3	#Max	QPSK	21.85	-0.7	21.15	30	PASS
Band4	1.4	19957	6	#0	QPSK	21.76	-0.7	21.06	30	PASS
Band4	1.4	19957	1	#0	16QAM	21.72	-0.7	21.02	30	PASS
Band4	1.4	19957	1	#Mid	16QAM	21.85	-0.7	21.15	30	PASS
Band4	1.4	19957	1	#Max	16QAM	21.75	-0.7	21.05	30	PASS
Band4	1.4	19957	3	#0	16QAM	22.03	-0.7	21.33	30	PASS
Band4	1.4	19957	3	#Mid	16QAM	22.08	-0.7	21.38	30	PASS
Band4	1.4	19957	3	#Max	16QAM	22.08	-0.7	21.38	30	PASS
Band4	1.4	19957	6	#0	16QAM	21.45	-0.7	20.75	30	PASS
Band4	1.4	20175	1	#0	QPSK	21.77	-0.7	21.07	30	PASS
Band4	1.4	20175	1	#Mid	QPSK	22.00	-0.7	21.30	30	PASS
Band4	1.4	20175	1	#Max	QPSK	21.82	-0.7	21.12	30	PASS
Band4	1.4	20175	3	#0	QPSK	21.81	-0.7	21.11	30	PASS
Band4	1.4	20175	3	#Mid	QPSK	21.82	-0.7	21.12	30	PASS
Band4	1.4	20175	3	#Max	QPSK	21.85	-0.7	21.15	30	PASS
Band4	1.4	20175	6	#0	QPSK	21.77	-0.7	21.07	30	PASS
Band4	1.4	20175	1	#0	16QAM	21.93	-0.7	21.23	30	PASS
Band4	1.4	20175	1	#Mid	16QAM	22.12	-0.7	21.42	30	PASS
Band4	1.4	20175	1	#Max	16QAM	21.95	-0.7	21.25	30	PASS
Band4	1.4	20175	3	#0	16QAM	22.04	-0.7	21.34	30	PASS
Band4	1.4	20175	3	#Mid	16QAM	22.08	-0.7	21.38	30	PASS
Band4	1.4	20175	3	#Max	16QAM	22.02	-0.7	21.32	30	PASS
Band4	1.4	20175	6	#0	16QAM	21.48	-0.7	20.78	30	PASS
Band4	1.4	20393	1	#0	QPSK	21.74	-0.7	21.04	30	PASS
Band4	1.4	20393	1	#Mid	QPSK	21.90	-0.7	21.20	30	PASS
Band4	1.4	20393	1	#Max	QPSK	21.73	-0.7	21.03	30	PASS
Band4	1.4	20393	3	#0	QPSK	21.82	-0.7	21.12	30	PASS
Band4	1.4	20393	3	#Mid	QPSK	21.81	-0.7	21.11	30	PASS
Band4	1.4	20393	3	#Max	QPSK	21.80	-0.7	21.10	30	PASS
Band4	1.4	20393	6	#0	QPSK	21.71	-0.7	21.01	30	PASS
Band4	1.4	20393	1	#0	16QAM	21.96	-0.7	21.26	30	PASS
Band4	1.4	20393	1	#Mid	16QAM	22.07	-0.7	21.37	30	PASS
Band4	1.4	20393	1	#Max	16QAM	21.92	-0.7	21.22	30	PASS
Band4	1.4	20393	3	#0	16QAM	22.07	-0.7	21.37	30	PASS
Band4	1.4	20393	3	#Mid	16QAM	22.08	-0.7	21.38	30	PASS
Band4	1.4	20393	3	#Max	16QAM	22.05	-0.7	21.35	30	PASS
Band4	1.4	20393	6	#0	16QAM	21.44	-0.7	20.74	30	PASS
Band4	3	19965	1	#0	QPSK	21.77	-0.7	21.07	30	PASS
Band4	3	19965	1	#Mid	QPSK	22.07	-0.7	21.37	30	PASS
Band4	3	19965	1	#Max	QPSK	21.74	-0.7	21.04	30	PASS
Band4	3	19965	8	#0	QPSK	21.72	-0.7	21.02	30	PASS
Band4	3	19965	8	#Mid	QPSK	21.76	-0.7	21.06	30	PASS
Band4	3	19965	8	#Max	QPSK	21.73	-0.7	21.03	30	PASS
Band4	3	19965	15	#0	QPSK	21.73	-0.7	21.03	30	PASS
Band4	3	19965	1	#0	16QAM	22.03	-0.7	21.33	30	PASS
Band4	3	19965	1	#Mid	16QAM	22.39	-0.7	21.69	30	PASS
Band4	3	19965	1	#Max	16QAM	22.02	-0.7	21.32	30	PASS
Band4	3	19965	8	#0	16QAM	21.31	-0.7	20.61	30	PASS
Band4	3	19965	8	#Mid	16QAM	21.28	-0.7	20.58	30	PASS
Band4	3	19965	8	#Max	16QAM	21.28	-0.7	20.58	30	PASS
Band4	3	19965	15	#0	16QAM	21.22	-0.7	20.52	30	PASS
Band4	3	20175	1	#0	QPSK	21.78	-0.7	21.08	30	PASS
Band4	3	20175	1	#Mid	QPSK	22.08	-0.7	21.38	30	PASS
Band4	3	20175	1	#Max	QPSK	21.84	-0.7	21.14	30	PASS

Band4	3	20175	8	#0	QPSK	21.72	-0.7	21.02	30	PASS
Band4	3	20175	8	#Mid	QPSK	21.75	-0.7	21.05	30	PASS
Band4	3	20175	8	#Max	QPSK	21.77	-0.7	21.07	30	PASS
Band4	3	20175	15	#0	QPSK	21.78	-0.7	21.08	30	PASS
Band4	3	20175	1	#0	16QAM	21.65	-0.7	20.95	30	PASS
Band4	3	20175	1	#Mid	16QAM	21.96	-0.7	21.26	30	PASS
Band4	3	20175	1	#Max	16QAM	21.68	-0.7	20.98	30	PASS
Band4	3	20175	8	#0	16QAM	21.25	-0.7	20.55	30	PASS
Band4	3	20175	8	#Mid	16QAM	21.28	-0.7	20.58	30	PASS
Band4	3	20175	8	#Max	16QAM	21.29	-0.7	20.59	30	PASS
Band4	3	20175	15	#0	16QAM	21.33	-0.7	20.63	30	PASS
Band4	3	20385	1	#0	QPSK	21.74	-0.7	21.04	30	PASS
Band4	3	20385	1	#Mid	QPSK	22.21	-0.7	21.51	30	PASS
Band4	3	20385	1	#Max	QPSK	21.67	-0.7	20.97	30	PASS
Band4	3	20385	8	#0	QPSK	21.73	-0.7	21.03	30	PASS
Band4	3	20385	8	#Mid	QPSK	21.78	-0.7	21.08	30	PASS
Band4	3	20385	8	#Max	QPSK	21.76	-0.7	21.06	30	PASS
Band4	3	20385	15	#0	QPSK	21.73	-0.7	21.03	30	PASS
Band4	3	20385	1	#0	16QAM	22.19	-0.7	21.49	30	PASS
Band4	3	20385	1	#Mid	16QAM	22.62	-0.7	21.92	30	PASS
Band4	3	20385	1	#Max	16QAM	22.16	-0.7	21.46	30	PASS
Band4	3	20385	8	#0	16QAM	21.29	-0.7	20.59	30	PASS
Band4	3	20385	8	#Mid	16QAM	21.32	-0.7	20.62	30	PASS
Band4	3	20385	8	#Max	16QAM	21.25	-0.7	20.55	30	PASS
Band4	3	20385	15	#0	16QAM	21.28	-0.7	20.58	30	PASS
Band4	5	19975	1	#0	QPSK	21.68	-0.7	20.98	30	PASS
Band4	5	19975	1	#Mid	QPSK	22.17	-0.7	21.47	30	PASS
Band4	5	19975	1	#Max	QPSK	21.66	-0.7	20.96	30	PASS
Band4	5	19975	12	#0	QPSK	21.74	-0.7	21.04	30	PASS
Band4	5	19975	12	#Mid	QPSK	21.78	-0.7	21.08	30	PASS
Band4	5	19975	12	#Max	QPSK	21.74	-0.7	21.04	30	PASS
Band4	5	19975	25	#0	QPSK	21.77	-0.7	21.07	30	PASS
Band4	5	19975	1	#0	16QAM	22.30	-0.7	21.60	30	PASS
Band4	5	19975	1	#Mid	16QAM	22.73	-0.7	22.03	30	PASS
Band4	5	19975	1	#Max	16QAM	22.27	-0.7	21.57	30	PASS
Band4	5	19975	12	#0	16QAM	21.25	-0.7	20.55	30	PASS
Band4	5	19975	12	#Mid	16QAM	21.36	-0.7	20.66	30	PASS
Band4	5	19975	12	#Max	16QAM	21.29	-0.7	20.59	30	PASS
Band4	5	19975	25	#0	16QAM	21.28	-0.7	20.58	30	PASS
Band4	5	20175	1	#0	QPSK	21.66	-0.7	20.96	30	PASS
Band4	5	20175	1	#Mid	QPSK	22.13	-0.7	21.43	30	PASS
Band4	5	20175	1	#Max	QPSK	21.74	-0.7	21.04	30	PASS
Band4	5	20175	12	#0	QPSK	21.71	-0.7	21.01	30	PASS
Band4	5	20175	12	#Mid	QPSK	21.80	-0.7	21.10	30	PASS
Band4	5	20175	12	#Max	QPSK	21.73	-0.7	21.03	30	PASS
Band4	5	20175	25	#0	QPSK	21.75	-0.7	21.05	30	PASS
Band4	5	20175	1	#0	16QAM	22.05	-0.7	21.35	30	PASS
Band4	5	20175	1	#Mid	16QAM	22.44	-0.7	21.74	30	PASS
Band4	5	20175	1	#Max	16QAM	22.09	-0.7	21.39	30	PASS
Band4	5	20175	12	#0	16QAM	21.22	-0.7	20.52	30	PASS
Band4	5	20175	12	#Mid	16QAM	21.30	-0.7	20.60	30	PASS
Band4	5	20175	12	#Max	16QAM	21.25	-0.7	20.55	30	PASS
Band4	5	20175	25	#0	16QAM	21.31	-0.7	20.61	30	PASS
Band4	5	20375	1	#0	QPSK	21.60	-0.7	20.90	30	PASS
Band4	5	20375	1	#Mid	QPSK	21.98	-0.7	21.28	30	PASS
Band4	5	20375	1	#Max	QPSK	21.58	-0.7	20.88	30	PASS
Band4	5	20375	12	#0	QPSK	21.71	-0.7	21.01	30	PASS
Band4	5	20375	12	#Mid	QPSK	21.83	-0.7	21.13	30	PASS
Band4	5	20375	12	#Max	QPSK	21.69	-0.7	20.99	30	PASS
Band4	5	20375	25	#0	QPSK	21.75	-0.7	21.05	30	PASS
Band4	5	20375	1	#0	16QAM	22.03	-0.7	21.33	30	PASS

Band4	5	20375	1	#Mid	16QAM	22.37	-0.7	21.67	30	PASS
Band4	5	20375	1	#Max	16QAM	22.01	-0.7	21.31	30	PASS
Band4	5	20375	12	#0	16QAM	21.27	-0.7	20.57	30	PASS
Band4	5	20375	12	#Mid	16QAM	21.36	-0.7	20.66	30	PASS
Band4	5	20375	12	#Max	16QAM	21.27	-0.7	20.57	30	PASS
Band4	5	20375	25	#0	16QAM	21.23	-0.7	20.53	30	PASS
Band4	10	20000	1	#0	QPSK	21.77	-0.7	21.07	30	PASS
Band4	10	20000	1	#Mid	QPSK	21.91	-0.7	21.21	30	PASS
Band4	10	20000	1	#Max	QPSK	21.70	-0.7	21.00	30	PASS
Band4	10	20000	25	#0	QPSK	21.76	-0.7	21.06	30	PASS
Band4	10	20000	25	#Mid	QPSK	21.80	-0.7	21.10	30	PASS
Band4	10	20000	25	#Max	QPSK	21.79	-0.7	21.09	30	PASS
Band4	10	20000	50	#0	QPSK	21.81	-0.7	21.11	30	PASS
Band4	10	20000	1	#0	16QAM	21.72	-0.7	21.02	30	PASS
Band4	10	20000	1	#Mid	16QAM	21.82	-0.7	21.12	30	PASS
Band4	10	20000	1	#Max	16QAM	21.64	-0.7	20.94	30	PASS
Band4	10	20000	25	#0	16QAM	21.30	-0.7	20.60	30	PASS
Band4	10	20000	25	#Mid	16QAM	21.34	-0.7	20.64	30	PASS
Band4	10	20000	25	#Max	16QAM	21.33	-0.7	20.63	30	PASS
Band4	10	20000	50	#0	16QAM	21.38	-0.7	20.68	30	PASS
Band4	10	20175	1	#0	QPSK	21.67	-0.7	20.97	30	PASS
Band4	10	20175	1	#Mid	QPSK	21.86	-0.7	21.16	30	PASS
Band4	10	20175	1	#Max	QPSK	21.81	-0.7	21.11	30	PASS
Band4	10	20175	25	#0	QPSK	21.72	-0.7	21.02	30	PASS
Band4	10	20175	25	#Mid	QPSK	21.84	-0.7	21.14	30	PASS
Band4	10	20175	25	#Max	QPSK	21.82	-0.7	21.12	30	PASS
Band4	10	20175	50	#0	QPSK	21.79	-0.7	21.09	30	PASS
Band4	10	20175	1	#0	16QAM	22.15	-0.7	21.45	30	PASS
Band4	10	20175	1	#Mid	16QAM	22.36	-0.7	21.66	30	PASS
Band4	10	20175	1	#Max	16QAM	22.28	-0.7	21.58	30	PASS
Band4	10	20175	25	#0	16QAM	21.35	-0.7	20.65	30	PASS
Band4	10	20175	25	#Mid	16QAM	21.43	-0.7	20.73	30	PASS
Band4	10	20175	25	#Max	16QAM	21.49	-0.7	20.79	30	PASS
Band4	10	20175	50	#0	16QAM	21.38	-0.7	20.68	30	PASS
Band4	10	20350	1	#0	QPSK	21.86	-0.7	21.16	30	PASS
Band4	10	20350	1	#Mid	QPSK	21.87	-0.7	21.17	30	PASS
Band4	10	20350	1	#Max	QPSK	21.80	-0.7	21.10	30	PASS
Band4	10	20350	25	#0	QPSK	21.85	-0.7	21.15	30	PASS
Band4	10	20350	25	#Mid	QPSK	21.79	-0.7	21.09	30	PASS
Band4	10	20350	25	#Max	QPSK	21.76	-0.7	21.06	30	PASS
Band4	10	20350	50	#0	QPSK	21.80	-0.7	21.10	30	PASS
Band4	10	20350	1	#0	16QAM	22.03	-0.7	21.33	30	PASS
Band4	10	20350	1	#Mid	16QAM	22.10	-0.7	21.40	30	PASS
Band4	10	20350	1	#Max	16QAM	21.91	-0.7	21.21	30	PASS
Band4	10	20350	25	#0	16QAM	21.33	-0.7	20.63	30	PASS
Band4	10	20350	25	#Mid	16QAM	21.36	-0.7	20.66	30	PASS
Band4	10	20350	25	#Max	16QAM	21.30	-0.7	20.60	30	PASS
Band4	10	20350	50	#0	16QAM	21.34	-0.7	20.64	30	PASS
Band4	15	20025	1	#0	QPSK	21.70	-0.7	21.00	30	PASS
Band4	15	20025	1	#Mid	QPSK	21.91	-0.7	21.21	30	PASS
Band4	15	20025	1	#Max	QPSK	21.88	-0.7	21.18	30	PASS
Band4	15	20025	36	#0	QPSK	21.73	-0.7	21.03	30	PASS
Band4	15	20025	36	#Mid	QPSK	21.71	-0.7	21.01	30	PASS
Band4	15	20025	36	#Max	QPSK	21.76	-0.7	21.06	30	PASS
Band4	15	20025	75	#0	QPSK	21.72	-0.7	21.02	30	PASS
Band4	15	20025	1	#0	16QAM	21.96	-0.7	21.26	30	PASS
Band4	15	20025	1	#Mid	16QAM	22.22	-0.7	21.52	30	PASS
Band4	15	20025	1	#Max	16QAM	21.83	-0.7	21.13	30	PASS
Band4	15	20025	36	#0	16QAM	21.33	-0.7	20.63	30	PASS
Band4	15	20025	36	#Mid	16QAM	21.32	-0.7	20.62	30	PASS
Band4	15	20025	36	#Max	16QAM	21.32	-0.7	20.62	30	PASS

Band4	15	20025	75	#0	16QAM	21.24	-0.7	20.54	30	PASS
Band4	15	20175	1	#0	QPSK	21.59	-0.7	20.89	30	PASS
Band4	15	20175	1	#Mid	QPSK	22.09	-0.7	21.39	30	PASS
Band4	15	20175	1	#Max	QPSK	21.72	-0.7	21.02	30	PASS
Band4	15	20175	36	#0	QPSK	21.74	-0.7	21.04	30	PASS
Band4	15	20175	36	#Mid	QPSK	21.83	-0.7	21.13	30	PASS
Band4	15	20175	36	#Max	QPSK	21.84	-0.7	21.14	30	PASS
Band4	15	20175	75	#0	QPSK	21.79	-0.7	21.09	30	PASS
Band4	15	20175	1	#0	16QAM	21.73	-0.7	21.03	30	PASS
Band4	15	20175	1	#Mid	16QAM	22.17	-0.7	21.47	30	PASS
Band4	15	20175	1	#Max	16QAM	21.86	-0.7	21.16	30	PASS
Band4	15	20175	36	#0	16QAM	21.21	-0.7	20.51	30	PASS
Band4	15	20175	36	#Mid	16QAM	21.28	-0.7	20.58	30	PASS
Band4	15	20175	36	#Max	16QAM	21.33	-0.7	20.63	30	PASS
Band4	15	20175	75	#0	16QAM	21.29	-0.7	20.59	30	PASS
Band4	15	20325	1	#0	QPSK	21.72	-0.7	21.02	30	PASS
Band4	15	20325	1	#Mid	QPSK	21.98	-0.7	21.28	30	PASS
Band4	15	20325	1	#Max	QPSK	21.67	-0.7	20.97	30	PASS
Band4	15	20325	36	#0	QPSK	21.90	-0.7	21.20	30	PASS
Band4	15	20325	36	#Mid	QPSK	21.82	-0.7	21.12	30	PASS
Band4	15	20325	36	#Max	QPSK	21.76	-0.7	21.06	30	PASS
Band4	15	20325	75	#0	QPSK	21.85	-0.7	21.15	30	PASS
Band4	15	20325	1	#0	16QAM	22.21	-0.7	21.51	30	PASS
Band4	15	20325	1	#Mid	16QAM	22.56	-0.7	21.86	30	PASS
Band4	15	20325	1	#Max	16QAM	22.16	-0.7	21.46	30	PASS
Band4	15	20325	36	#0	16QAM	21.39	-0.7	20.69	30	PASS
Band4	15	20325	36	#Mid	16QAM	21.38	-0.7	20.68	30	PASS
Band4	15	20325	36	#Max	16QAM	21.28	-0.7	20.58	30	PASS
Band4	15	20325	75	#0	16QAM	21.33	-0.7	20.63	30	PASS
Band4	20	20050	1	#0	QPSK	21.49	-0.7	20.79	30	PASS
Band4	20	20050	1	#Mid	QPSK	21.80	-0.7	21.10	30	PASS
Band4	20	20050	1	#Max	QPSK	21.50	-0.7	20.80	30	PASS
Band4	20	20050	50	#0	QPSK	21.76	-0.7	21.06	30	PASS
Band4	20	20050	50	#Mid	QPSK	21.74	-0.7	21.04	30	PASS
Band4	20	20050	50	#Max	QPSK	21.74	-0.7	21.04	30	PASS
Band4	20	20050	100	#0	QPSK	21.78	-0.7	21.08	30	PASS
Band4	20	20050	1	#0	16QAM	21.85	-0.7	21.15	30	PASS
Band4	20	20050	1	#Mid	16QAM	22.15	-0.7	21.45	30	PASS
Band4	20	20050	1	#Max	16QAM	21.85	-0.7	21.15	30	PASS
Band4	20	20050	50	#0	16QAM	21.30	-0.7	20.60	30	PASS
Band4	20	20050	50	#Mid	16QAM	21.32	-0.7	20.62	30	PASS
Band4	20	20050	50	#Max	16QAM	21.33	-0.7	20.63	30	PASS
Band4	20	20050	100	#0	16QAM	21.35	-0.7	20.65	30	PASS
Band4	20	20175	1	#0	QPSK	21.34	-0.7	20.64	30	PASS
Band4	20	20175	1	#Mid	QPSK	21.89	-0.7	21.19	30	PASS
Band4	20	20175	1	#Max	QPSK	21.66	-0.7	20.96	30	PASS
Band4	20	20175	50	#0	QPSK	21.73	-0.7	21.03	30	PASS
Band4	20	20175	50	#Mid	QPSK	21.83	-0.7	21.13	30	PASS
Band4	20	20175	50	#Max	QPSK	21.86	-0.7	21.16	30	PASS
Band4	20	20175	100	#0	QPSK	21.78	-0.7	21.08	30	PASS
Band4	20	20175	1	#0	16QAM	21.81	-0.7	21.11	30	PASS
Band4	20	20175	1	#Mid	16QAM	22.22	-0.7	21.52	30	PASS
Band4	20	20175	1	#Max	16QAM	22.01	-0.7	21.31	30	PASS
Band4	20	20175	50	#0	16QAM	21.32	-0.7	20.62	30	PASS
Band4	20	20175	50	#Mid	16QAM	21.43	-0.7	20.73	30	PASS
Band4	20	20175	50	#Max	16QAM	21.45	-0.7	20.75	30	PASS
Band4	20	20175	100	#0	16QAM	21.36	-0.7	20.66	30	PASS
Band4	20	20300	1	#0	QPSK	21.61	-0.7	20.91	30	PASS
Band4	20	20300	1	#Mid	QPSK	21.99	-0.7	21.29	30	PASS
Band4	20	20300	1	#Max	QPSK	21.55	-0.7	20.85	30	PASS
Band4	20	20300	50	#0	QPSK	21.86	-0.7	21.16	30	PASS

Band4	20	20300	50	#Mid	QPSK	21.87	-0.7	21.17	30	PASS
Band4	20	20300	50	#Max	QPSK	21.81	-0.7	21.11	30	PASS
Band4	20	20300	100	#0	QPSK	21.89	-0.7	21.19	30	PASS
Band4	20	20300	1	#0	16QAM	21.86	-0.7	21.16	30	PASS
Band4	20	20300	1	#Mid	16QAM	22.25	-0.7	21.55	30	PASS
Band4	20	20300	1	#Max	16QAM	21.87	-0.7	21.17	30	PASS
Band4	20	20300	50	#0	16QAM	21.37	-0.7	20.67	30	PASS
Band4	20	20300	50	#Mid	16QAM	21.38	-0.7	20.68	30	PASS
Band4	20	20300	50	#Max	16QAM	21.32	-0.7	20.62	30	PASS
Band4	20	20300	100	#0	16QAM	21.39	-0.7	20.69	30	PASS



Band	Bandwidth (MHz)	UL Channel	RB Size	RB Position	Modulation	Power (dBm)	Gain (dB)	ERP (dBm)	ERP Limit (dBm)	Verdict
Band5	1.4	20407	1	#0	QPSK	23.39	-1.74	19.50	38.45	PASS
Band5	1.4	20407	1	#Mid	QPSK	23.59	-1.74	19.70	38.45	PASS
Band5	1.4	20407	1	#Max	QPSK	23.41	-1.74	19.52	38.45	PASS
Band5	1.4	20407	3	#0	QPSK	23.43	-1.74	19.54	38.45	PASS
Band5	1.4	20407	3	#Mid	QPSK	23.46	-1.74	19.57	38.45	PASS
Band5	1.4	20407	3	#Max	QPSK	23.44	-1.74	19.55	38.45	PASS
Band5	1.4	20407	6	#0	QPSK	22.37	-1.74	18.48	38.45	PASS
Band5	1.4	20407	1	#0	16QAM	22.31	-1.74	18.42	38.45	PASS
Band5	1.4	20407	1	#Mid	16QAM	22.46	-1.74	18.57	38.45	PASS
Band5	1.4	20407	1	#Max	16QAM	22.30	-1.74	18.41	38.45	PASS
Band5	1.4	20407	3	#0	16QAM	22.67	-1.74	18.78	38.45	PASS
Band5	1.4	20407	3	#Mid	16QAM	22.62	-1.74	18.73	38.45	PASS
Band5	1.4	20407	3	#Max	16QAM	22.65	-1.74	18.76	38.45	PASS
Band5	1.4	20407	6	#0	16QAM	21.66	-1.74	17.77	38.45	PASS
Band5	1.4	20525	1	#0	QPSK	23.53	-1.74	19.64	38.45	PASS
Band5	1.4	20525	1	#Mid	QPSK	23.65	-1.74	19.76	38.45	PASS
Band5	1.4	20525	1	#Max	QPSK	23.60	-1.74	19.71	38.45	PASS
Band5	1.4	20525	3	#0	QPSK	23.47	-1.74	19.58	38.45	PASS
Band5	1.4	20525	3	#Mid	QPSK	23.50	-1.74	19.61	38.45	PASS
Band5	1.4	20525	3	#Max	QPSK	23.53	-1.74	19.64	38.45	PASS
Band5	1.4	20525	6	#0	QPSK	22.49	-1.74	18.60	38.45	PASS
Band5	1.4	20525	1	#0	16QAM	22.62	-1.74	18.73	38.45	PASS
Band5	1.4	20525	1	#Mid	16QAM	22.79	-1.74	18.90	38.45	PASS
Band5	1.4	20525	1	#Max	16QAM	22.67	-1.74	18.78	38.45	PASS
Band5	1.4	20525	3	#0	16QAM	22.68	-1.74	18.79	38.45	PASS
Band5	1.4	20525	3	#Mid	16QAM	22.74	-1.74	18.85	38.45	PASS
Band5	1.4	20525	3	#Max	16QAM	22.69	-1.74	18.80	38.45	PASS
Band5	1.4	20525	6	#0	16QAM	21.73	-1.74	17.84	38.45	PASS
Band5	1.4	20643	1	#0	QPSK	23.56	-1.74	19.67	38.45	PASS
Band5	1.4	20643	1	#Mid	QPSK	23.74	-1.74	19.85	38.45	PASS
Band5	1.4	20643	1	#Max	QPSK	23.57	-1.74	19.68	38.45	PASS
Band5	1.4	20643	3	#0	QPSK	23.68	-1.74	19.79	38.45	PASS
Band5	1.4	20643	3	#Mid	QPSK	23.64	-1.74	19.75	38.45	PASS
Band5	1.4	20643	3	#Max	QPSK	23.64	-1.74	19.75	38.45	PASS
Band5	1.4	20643	6	#0	QPSK	22.58	-1.74	18.69	38.45	PASS
Band5	1.4	20643	1	#0	16QAM	22.73	-1.74	18.84	38.45	PASS
Band5	1.4	20643	1	#Mid	16QAM	22.92	-1.74	19.03	38.45	PASS
Band5	1.4	20643	1	#Max	16QAM	22.75	-1.74	18.86	38.45	PASS
Band5	1.4	20643	3	#0	16QAM	22.89	-1.74	19.00	38.45	PASS
Band5	1.4	20643	3	#Mid	16QAM	22.88	-1.74	18.99	38.45	PASS
Band5	1.4	20643	3	#Max	16QAM	22.91	-1.74	19.02	38.45	PASS
Band5	1.4	20643	6	#0	16QAM	21.83	-1.74	17.94	38.45	PASS
Band5	3	20415	1	#0	QPSK	23.39	-1.74	19.50	38.45	PASS
Band5	3	20415	1	#Mid	QPSK	23.66	-1.74	19.77	38.45	PASS
Band5	3	20415	1	#Max	QPSK	23.29	-1.74	19.40	38.45	PASS
Band5	3	20415	8	#0	QPSK	22.33	-1.74	18.44	38.45	PASS
Band5	3	20415	8	#Mid	QPSK	22.37	-1.74	18.48	38.45	PASS
Band5	3	20415	8	#Max	QPSK	22.34	-1.74	18.45	38.45	PASS
Band5	3	20415	15	#0	QPSK	22.32	-1.74	18.43	38.45	PASS
Band5	3	20415	1	#0	16QAM	22.94	-1.74	19.05	38.45	PASS
Band5	3	20415	1	#Mid	16QAM	23.13	-1.74	19.24	38.45	PASS
Band5	3	20415	1	#Max	16QAM	22.85	-1.74	18.96	38.45	PASS
Band5	3	20415	8	#0	16QAM	21.47	-1.74	17.58	38.45	PASS
Band5	3	20415	8	#Mid	16QAM	21.48	-1.74	17.59	38.45	PASS
Band5	3	20415	8	#Max	16QAM	21.46	-1.74	17.57	38.45	PASS
Band5	3	20415	15	#0	16QAM	21.47	-1.74	17.58	38.45	PASS
Band5	3	20525	1	#0	QPSK	23.45	-1.74	19.56	38.45	PASS
Band5	3	20525	1	#Mid	QPSK	23.76	-1.74	19.87	38.45	PASS
Band5	3	20525	1	#Max	QPSK	23.64	-1.74	19.75	38.45	PASS

Band5	3	20525	8	#0	QPSK	22.46	-1.74	18.57	38.45	PASS
Band5	3	20525	8	#Mid	QPSK	22.46	-1.74	18.57	38.45	PASS
Band5	3	20525	8	#Max	QPSK	22.46	-1.74	18.57	38.45	PASS
Band5	3	20525	15	#0	QPSK	22.44	-1.74	18.55	38.45	PASS
Band5	3	20525	1	#0	16QAM	22.68	-1.74	18.79	38.45	PASS
Band5	3	20525	1	#Mid	16QAM	22.99	-1.74	19.10	38.45	PASS
Band5	3	20525	1	#Max	16QAM	22.82	-1.74	18.93	38.45	PASS
Band5	3	20525	8	#0	16QAM	21.55	-1.74	17.66	38.45	PASS
Band5	3	20525	8	#Mid	16QAM	21.56	-1.74	17.67	38.45	PASS
Band5	3	20525	8	#Max	16QAM	21.55	-1.74	17.66	38.45	PASS
Band5	3	20525	15	#0	16QAM	21.46	-1.74	17.57	38.45	PASS
Band5	3	20635	1	#0	QPSK	23.62	-1.74	19.73	38.45	PASS
Band5	3	20635	1	#Mid	QPSK	23.98	-1.74	20.09	38.45	PASS
Band5	3	20635	1	#Max	QPSK	23.76	-1.74	19.87	38.45	PASS
Band5	3	20635	8	#0	QPSK	22.61	-1.74	18.72	38.45	PASS
Band5	3	20635	8	#Mid	QPSK	22.63	-1.74	18.74	38.45	PASS
Band5	3	20635	8	#Max	QPSK	22.59	-1.74	18.70	38.45	PASS
Band5	3	20635	15	#0	QPSK	22.60	-1.74	18.71	38.45	PASS
Band5	3	20635	1	#0	16QAM	22.55	-1.74	18.66	38.45	PASS
Band5	3	20635	1	#Mid	16QAM	22.80	-1.74	18.91	38.45	PASS
Band5	3	20635	1	#Max	16QAM	22.47	-1.74	18.58	38.45	PASS
Band5	3	20635	8	#0	16QAM	21.66	-1.74	17.77	38.45	PASS
Band5	3	20635	8	#Mid	16QAM	21.70	-1.74	17.81	38.45	PASS
Band5	3	20635	8	#Max	16QAM	21.65	-1.74	17.76	38.45	PASS
Band5	3	20635	15	#0	16QAM	21.71	-1.74	17.82	38.45	PASS
Band5	5	20425	1	#0	QPSK	23.36	-1.74	19.47	38.45	PASS
Band5	5	20425	1	#Mid	QPSK	23.70	-1.74	19.81	38.45	PASS
Band5	5	20425	1	#Max	QPSK	23.33	-1.74	19.44	38.45	PASS
Band5	5	20425	12	#0	QPSK	22.41	-1.74	18.52	38.45	PASS
Band5	5	20425	12	#Mid	QPSK	22.42	-1.74	18.53	38.45	PASS
Band5	5	20425	12	#Max	QPSK	22.47	-1.74	18.58	38.45	PASS
Band5	5	20425	25	#0	QPSK	22.46	-1.74	18.57	38.45	PASS
Band5	5	20425	1	#0	16QAM	22.71	-1.74	18.82	38.45	PASS
Band5	5	20425	1	#Mid	16QAM	23.12	-1.74	19.23	38.45	PASS
Band5	5	20425	1	#Max	16QAM	22.68	-1.74	18.79	38.45	PASS
Band5	5	20425	12	#0	16QAM	21.32	-1.74	17.43	38.45	PASS
Band5	5	20425	12	#Mid	16QAM	21.45	-1.74	17.56	38.45	PASS
Band5	5	20425	12	#Max	16QAM	21.49	-1.74	17.60	38.45	PASS
Band5	5	20425	25	#0	16QAM	21.52	-1.74	17.63	38.45	PASS
Band5	5	20525	1	#0	QPSK	23.33	-1.74	19.44	38.45	PASS
Band5	5	20525	1	#Mid	QPSK	23.69	-1.74	19.80	38.45	PASS
Band5	5	20525	1	#Max	QPSK	23.46	-1.74	19.57	38.45	PASS
Band5	5	20525	12	#0	QPSK	22.55	-1.74	18.66	38.45	PASS
Band5	5	20525	12	#Mid	QPSK	22.52	-1.74	18.63	38.45	PASS
Band5	5	20525	12	#Max	QPSK	22.47	-1.74	18.58	38.45	PASS
Band5	5	20525	25	#0	QPSK	22.52	-1.74	18.63	38.45	PASS
Band5	5	20525	1	#0	16QAM	22.66	-1.74	18.77	38.45	PASS
Band5	5	20525	1	#Mid	16QAM	23.12	-1.74	19.23	38.45	PASS
Band5	5	20525	1	#Max	16QAM	22.80	-1.74	18.91	38.45	PASS
Band5	5	20525	12	#0	16QAM	21.63	-1.74	17.74	38.45	PASS
Band5	5	20525	12	#Mid	16QAM	21.62	-1.74	17.73	38.45	PASS
Band5	5	20525	12	#Max	16QAM	21.59	-1.74	17.70	38.45	PASS
Band5	5	20525	25	#0	16QAM	21.54	-1.74	17.65	38.45	PASS
Band5	5	20625	1	#0	QPSK	23.56	-1.74	19.67	38.45	PASS
Band5	5	20625	1	#Mid	QPSK	23.96	-1.74	20.07	38.45	PASS
Band5	5	20625	1	#Max	QPSK	23.60	-1.74	19.71	38.45	PASS
Band5	5	20625	12	#0	QPSK	22.56	-1.74	18.67	38.45	PASS
Band5	5	20625	12	#Mid	QPSK	22.69	-1.74	18.80	38.45	PASS
Band5	5	20625	12	#Max	QPSK	22.58	-1.74	18.69	38.45	PASS
Band5	5	20625	25	#0	QPSK	22.62	-1.74	18.73	38.45	PASS
Band5	5	20625	1	#0	16QAM	23.15	-1.74	19.26	38.45	PASS

Band5	5	20625	1	#Mid	16QAM	23.51	-1.74	19.62	38.45	PASS
Band5	5	20625	1	#Max	16QAM	23.11	-1.74	19.22	38.45	PASS
Band5	5	20625	12	#0	16QAM	21.67	-1.74	17.78	38.45	PASS
Band5	5	20625	12	#Mid	16QAM	21.75	-1.74	17.86	38.45	PASS
Band5	5	20625	12	#Max	16QAM	21.62	-1.74	17.73	38.45	PASS
Band5	5	20625	25	#0	16QAM	21.65	-1.74	17.76	38.45	PASS
Band5	10	20450	1	#0	QPSK	23.40	-1.74	19.51	38.45	PASS
Band5	10	20450	1	#Mid	QPSK	23.55	-1.74	19.66	38.45	PASS
Band5	10	20450	1	#Max	QPSK	23.53	-1.74	19.64	38.45	PASS
Band5	10	20450	25	#0	QPSK	22.26	-1.74	18.37	38.45	PASS
Band5	10	20450	25	#Mid	QPSK	22.42	-1.74	18.53	38.45	PASS
Band5	10	20450	25	#Max	QPSK	22.35	-1.74	18.46	38.45	PASS
Band5	10	20450	50	#0	QPSK	22.32	-1.74	18.43	38.45	PASS
Band5	10	20450	1	#0	16QAM	22.26	-1.74	18.37	38.45	PASS
Band5	10	20450	1	#Mid	16QAM	22.41	-1.74	18.52	38.45	PASS
Band5	10	20450	1	#Max	16QAM	22.32	-1.74	18.43	38.45	PASS
Band5	10	20450	25	#0	16QAM	21.34	-1.74	17.45	38.45	PASS
Band5	10	20450	25	#Mid	16QAM	21.43	-1.74	17.54	38.45	PASS
Band5	10	20450	25	#Max	16QAM	21.42	-1.74	17.53	38.45	PASS
Band5	10	20450	50	#0	16QAM	21.38	-1.74	17.49	38.45	PASS
Band5	10	20525	1	#0	QPSK	23.33	-1.74	19.44	38.45	PASS
Band5	10	20525	1	#Mid	QPSK	23.58	-1.74	19.69	38.45	PASS
Band5	10	20525	1	#Max	QPSK	23.62	-1.74	19.73	38.45	PASS
Band5	10	20525	25	#0	QPSK	22.60	-1.74	18.71	38.45	PASS
Band5	10	20525	25	#Mid	QPSK	22.49	-1.74	18.60	38.45	PASS
Band5	10	20525	25	#Max	QPSK	22.61	-1.74	18.72	38.45	PASS
Band5	10	20525	50	#0	QPSK	22.57	-1.74	18.68	38.45	PASS
Band5	10	20525	1	#0	16QAM	22.77	-1.74	18.88	38.45	PASS
Band5	10	20525	1	#Mid	16QAM	23.04	-1.74	19.15	38.45	PASS
Band5	10	20525	1	#Max	16QAM	23.09	-1.74	19.20	38.45	PASS
Band5	10	20525	25	#0	16QAM	21.65	-1.74	17.76	38.45	PASS
Band5	10	20525	25	#Mid	16QAM	21.62	-1.74	17.73	38.45	PASS
Band5	10	20525	25	#Max	16QAM	21.69	-1.74	17.80	38.45	PASS
Band5	10	20525	50	#0	16QAM	21.68	-1.74	17.79	38.45	PASS
Band5	10	20600	1	#0	QPSK	23.56	-1.74	19.67	38.45	PASS
Band5	10	20600	1	#Mid	QPSK	23.73	-1.74	19.84	38.45	PASS
Band5	10	20600	1	#Max	QPSK	23.66	-1.74	19.77	38.45	PASS
Band5	10	20600	25	#0	QPSK	22.58	-1.74	18.69	38.45	PASS
Band5	10	20600	25	#Mid	QPSK	22.63	-1.74	18.74	38.45	PASS
Band5	10	20600	25	#Max	QPSK	22.69	-1.74	18.80	38.45	PASS
Band5	10	20600	50	#0	QPSK	22.63	-1.74	18.74	38.45	PASS
Band5	10	20600	1	#0	16QAM	22.72	-1.74	18.83	38.45	PASS
Band5	10	20600	1	#Mid	16QAM	22.91	-1.74	19.02	38.45	PASS
Band5	10	20600	1	#Max	16QAM	22.85	-1.74	18.96	38.45	PASS
Band5	10	20600	25	#0	16QAM	21.63	-1.74	17.74	38.45	PASS
Band5	10	20600	25	#Mid	16QAM	21.74	-1.74	17.85	38.45	PASS
Band5	10	20600	25	#Max	16QAM	21.75	-1.74	17.86	38.45	PASS
Band5	10	20600	50	#0	16QAM	21.73	-1.74	17.84	38.45	PASS

Band	Bandwidth (MHz)	UL Channel	RB Size	RB Position	Modulation	Power (dBm)	Gain (dB)	EIRP (dBm)	EIRP Limit (dBm)	Verdict
Band7	5	20775	1	#0	QPSK	22.73	-3.62	19.11	33.01	PASS
Band7	5	20775	1	#Mid	QPSK	23.06	-3.62	19.44	33.01	PASS
Band7	5	20775	1	#Max	QPSK	22.78	-3.62	19.16	33.01	PASS
Band7	5	20775	12	#0	QPSK	21.87	-3.62	18.25	33.01	PASS
Band7	5	20775	12	#Mid	QPSK	21.94	-3.62	18.32	33.01	PASS
Band7	5	20775	12	#Max	QPSK	21.84	-3.62	18.22	33.01	PASS
Band7	5	20775	25	#0	QPSK	21.91	-3.62	18.29	33.01	PASS
Band7	5	20775	1	#0	16QAM	22.27	-3.62	18.65	33.01	PASS
Band7	5	20775	1	#Mid	16QAM	22.69	-3.62	19.07	33.01	PASS
Band7	5	20775	1	#Max	16QAM	22.35	-3.62	18.73	33.01	PASS
Band7	5	20775	12	#0	16QAM	20.89	-3.62	17.27	33.01	PASS
Band7	5	20775	12	#Mid	16QAM	20.92	-3.62	17.30	33.01	PASS
Band7	5	20775	12	#Max	16QAM	20.89	-3.62	17.27	33.01	PASS
Band7	5	20775	25	#0	16QAM	20.89	-3.62	17.27	33.01	PASS
Band7	5	21100	1	#0	QPSK	22.66	-3.62	19.04	33.01	PASS
Band7	5	21100	1	#Mid	QPSK	23.14	-3.62	19.52	33.01	PASS
Band7	5	21100	1	#Max	QPSK	22.64	-3.62	19.02	33.01	PASS
Band7	5	21100	12	#0	QPSK	21.72	-3.62	18.10	33.01	PASS
Band7	5	21100	12	#Mid	QPSK	21.82	-3.62	18.20	33.01	PASS
Band7	5	21100	12	#Max	QPSK	21.74	-3.62	18.12	33.01	PASS
Band7	5	21100	25	#0	QPSK	21.81	-3.62	18.19	33.01	PASS
Band7	5	21100	1	#0	16QAM	22.03	-3.62	18.41	33.01	PASS
Band7	5	21100	1	#Mid	16QAM	22.40	-3.62	18.78	33.01	PASS
Band7	5	21100	1	#Max	16QAM	22.06	-3.62	18.44	33.01	PASS
Band7	5	21100	12	#0	16QAM	20.69	-3.62	17.07	33.01	PASS
Band7	5	21100	12	#Mid	16QAM	20.73	-3.62	17.11	33.01	PASS
Band7	5	21100	12	#Max	16QAM	20.68	-3.62	17.06	33.01	PASS
Band7	5	21100	25	#0	16QAM	20.81	-3.62	17.19	33.01	PASS
Band7	5	21425	1	#0	QPSK	22.51	-3.62	18.89	33.01	PASS
Band7	5	21425	1	#Mid	QPSK	22.91	-3.62	19.29	33.01	PASS
Band7	5	21425	1	#Max	QPSK	22.49	-3.62	18.87	33.01	PASS
Band7	5	21425	12	#0	QPSK	21.68	-3.62	18.06	33.01	PASS
Band7	5	21425	12	#Mid	QPSK	21.71	-3.62	18.09	33.01	PASS
Band7	5	21425	12	#Max	QPSK	21.69	-3.62	18.07	33.01	PASS
Band7	5	21425	25	#0	QPSK	21.70	-3.62	18.08	33.01	PASS
Band7	5	21425	1	#0	16QAM	21.90	-3.62	18.28	33.01	PASS
Band7	5	21425	1	#Mid	16QAM	22.35	-3.62	18.73	33.01	PASS
Band7	5	21425	1	#Max	16QAM	21.94	-3.62	18.32	33.01	PASS
Band7	5	21425	12	#0	16QAM	20.67	-3.62	17.05	33.01	PASS
Band7	5	21425	12	#Mid	16QAM	20.73	-3.62	17.11	33.01	PASS
Band7	5	21425	12	#Max	16QAM	20.72	-3.62	17.10	33.01	PASS
Band7	5	21425	25	#0	16QAM	20.68	-3.62	17.06	33.01	PASS
Band7	10	20800	1	#0	QPSK	22.84	-3.62	19.22	33.01	PASS
Band7	10	20800	1	#Mid	QPSK	22.92	-3.62	19.30	33.01	PASS
Band7	10	20800	1	#Max	QPSK	22.90	-3.62	19.28	33.01	PASS
Band7	10	20800	25	#0	QPSK	21.92	-3.62	18.30	33.01	PASS
Band7	10	20800	25	#Mid	QPSK	21.94	-3.62	18.32	33.01	PASS
Band7	10	20800	25	#Max	QPSK	22.00	-3.62	18.38	33.01	PASS
Band7	10	20800	50	#0	QPSK	21.97	-3.62	18.35	33.01	PASS
Band7	10	20800	1	#0	16QAM	22.25	-3.62	18.63	33.01	PASS
Band7	10	20800	1	#Mid	16QAM	22.41	-3.62	18.79	33.01	PASS
Band7	10	20800	1	#Max	16QAM	22.39	-3.62	18.77	33.01	PASS
Band7	10	20800	25	#0	16QAM	20.97	-3.62	17.35	33.01	PASS
Band7	10	20800	25	#Mid	16QAM	20.95	-3.62	17.33	33.01	PASS
Band7	10	20800	25	#Max	16QAM	21.03	-3.62	17.41	33.01	PASS
Band7	10	20800	50	#0	16QAM	20.98	-3.62	17.36	33.01	PASS
Band7	10	21100	1	#0	QPSK	22.79	-3.62	19.17	33.01	PASS
Band7	10	21100	1	#Mid	QPSK	22.80	-3.62	19.18	33.01	PASS
Band7	10	21100	1	#Max	QPSK	22.80	-3.62	19.18	33.01	PASS

Band7	10	21100	25	#0	QPSK	21.86	-3.62	18.24	33.01	PASS
Band7	10	21100	25	#Mid	QPSK	21.81	-3.62	18.19	33.01	PASS
Band7	10	21100	25	#Max	QPSK	21.81	-3.62	18.19	33.01	PASS
Band7	10	21100	50	#0	QPSK	21.86	-3.62	18.24	33.01	PASS
Band7	10	21100	1	#0	16QAM	21.99	-3.62	18.37	33.01	PASS
Band7	10	21100	1	#Mid	16QAM	22.04	-3.62	18.42	33.01	PASS
Band7	10	21100	1	#Max	16QAM	22.05	-3.62	18.43	33.01	PASS
Band7	10	21100	25	#0	16QAM	20.84	-3.62	17.22	33.01	PASS
Band7	10	21100	25	#Mid	16QAM	20.81	-3.62	17.19	33.01	PASS
Band7	10	21100	25	#Max	16QAM	20.87	-3.62	17.25	33.01	PASS
Band7	10	21100	50	#0	16QAM	20.89	-3.62	17.27	33.01	PASS
Band7	10	21400	1	#0	QPSK	22.74	-3.62	19.12	33.01	PASS
Band7	10	21400	1	#Mid	QPSK	22.85	-3.62	19.23	33.01	PASS
Band7	10	21400	1	#Max	QPSK	22.73	-3.62	19.11	33.01	PASS
Band7	10	21400	25	#0	QPSK	21.70	-3.62	18.08	33.01	PASS
Band7	10	21400	25	#Mid	QPSK	21.73	-3.62	18.11	33.01	PASS
Band7	10	21400	25	#Max	QPSK	21.81	-3.62	18.19	33.01	PASS
Band7	10	21400	50	#0	QPSK	21.76	-3.62	18.14	33.01	PASS
Band7	10	21400	1	#0	16QAM	21.64	-3.62	18.02	33.01	PASS
Band7	10	21400	1	#Mid	16QAM	21.69	-3.62	18.07	33.01	PASS
Band7	10	21400	1	#Max	16QAM	21.54	-3.62	17.92	33.01	PASS
Band7	10	21400	25	#0	16QAM	20.72	-3.62	17.10	33.01	PASS
Band7	10	21400	25	#Mid	16QAM	20.73	-3.62	17.11	33.01	PASS
Band7	10	21400	25	#Max	16QAM	20.82	-3.62	17.20	33.01	PASS
Band7	10	21400	50	#0	16QAM	20.74	-3.62	17.12	33.01	PASS
Band7	15	20825	1	#0	QPSK	22.81	-3.62	19.19	33.01	PASS
Band7	15	20825	1	#Mid	QPSK	23.06	-3.62	19.44	33.01	PASS
Band7	15	20825	1	#Max	QPSK	22.77	-3.62	19.15	33.01	PASS
Band7	15	20825	36	#0	QPSK	21.97	-3.62	18.35	33.01	PASS
Band7	15	20825	36	#Mid	QPSK	21.98	-3.62	18.36	33.01	PASS
Band7	15	20825	36	#Max	QPSK	21.96	-3.62	18.34	33.01	PASS
Band7	15	20825	75	#0	QPSK	21.95	-3.62	18.33	33.01	PASS
Band7	15	20825	1	#0	16QAM	22.04	-3.62	18.42	33.01	PASS
Band7	15	20825	1	#Mid	16QAM	22.48	-3.62	18.86	33.01	PASS
Band7	15	20825	1	#Max	16QAM	22.09	-3.62	18.47	33.01	PASS
Band7	15	20825	36	#0	16QAM	21.02	-3.62	17.40	33.01	PASS
Band7	15	20825	36	#Mid	16QAM	21.03	-3.62	17.41	33.01	PASS
Band7	15	20825	36	#Max	16QAM	21.00	-3.62	17.38	33.01	PASS
Band7	15	20825	75	#0	16QAM	20.93	-3.62	17.31	33.01	PASS
Band7	15	21100	1	#0	QPSK	22.75	-3.62	19.13	33.01	PASS
Band7	15	21100	1	#Mid	QPSK	23.15	-3.62	19.53	33.01	PASS
Band7	15	21100	1	#Max	QPSK	22.75	-3.62	19.13	33.01	PASS
Band7	15	21100	36	#0	QPSK	21.84	-3.62	18.22	33.01	PASS
Band7	15	21100	36	#Mid	QPSK	21.88	-3.62	18.26	33.01	PASS
Band7	15	21100	36	#Max	QPSK	21.85	-3.62	18.23	33.01	PASS
Band7	15	21100	75	#0	QPSK	21.91	-3.62	18.29	33.01	PASS
Band7	15	21100	1	#0	16QAM	21.84	-3.62	18.22	33.01	PASS
Band7	15	21100	1	#Mid	16QAM	22.16	-3.62	18.54	33.01	PASS
Band7	15	21100	1	#Max	16QAM	21.90	-3.62	18.28	33.01	PASS
Band7	15	21100	36	#0	16QAM	20.78	-3.62	17.16	33.01	PASS
Band7	15	21100	36	#Mid	16QAM	20.86	-3.62	17.24	33.01	PASS
Band7	15	21100	36	#Max	16QAM	20.81	-3.62	17.19	33.01	PASS
Band7	15	21100	75	#0	16QAM	20.92	-3.62	17.30	33.01	PASS
Band7	15	21375	1	#0	QPSK	22.64	-3.62	19.02	33.01	PASS
Band7	15	21375	1	#Mid	QPSK	23.03	-3.62	19.41	33.01	PASS
Band7	15	21375	1	#Max	QPSK	22.55	-3.62	18.93	33.01	PASS
Band7	15	21375	36	#0	QPSK	21.75	-3.62	18.13	33.01	PASS
Band7	15	21375	36	#Mid	QPSK	21.76	-3.62	18.14	33.01	PASS
Band7	15	21375	36	#Max	QPSK	21.79	-3.62	18.17	33.01	PASS
Band7	15	21375	75	#0	QPSK	21.80	-3.62	18.18	33.01	PASS
Band7	15	21375	1	#0	16QAM	22.13	-3.62	18.51	33.01	PASS

Band7	15	21375	1	#Mid	16QAM	22.54	-3.62	18.92	33.01	PASS
Band7	15	21375	1	#Max	16QAM	22.04	-3.62	18.42	33.01	PASS
Band7	15	21375	36	#0	16QAM	20.76	-3.62	17.14	33.01	PASS
Band7	15	21375	36	#Mid	16QAM	20.82	-3.62	17.20	33.01	PASS
Band7	15	21375	36	#Max	16QAM	20.81	-3.62	17.19	33.01	PASS
Band7	15	21375	75	#0	16QAM	20.80	-3.62	17.18	33.01	PASS
Band7	20	20850	1	#0	QPSK	22.74	-3.62	19.12	33.01	PASS
Band7	20	20850	1	#Mid	QPSK	23.08	-3.62	19.46	33.01	PASS
Band7	20	20850	1	#Max	QPSK	22.73	-3.62	19.11	33.01	PASS
Band7	20	20850	50	#0	QPSK	21.91	-3.62	18.29	33.01	PASS
Band7	20	20850	50	#Mid	QPSK	21.94	-3.62	18.32	33.01	PASS
Band7	20	20850	50	#Max	QPSK	21.93	-3.62	18.31	33.01	PASS
Band7	20	20850	100	#0	QPSK	21.92	-3.62	18.30	33.01	PASS
Band7	20	20850	1	#0	16QAM	21.95	-3.62	18.33	33.01	PASS
Band7	20	20850	1	#Mid	16QAM	22.27	-3.62	18.65	33.01	PASS
Band7	20	20850	1	#Max	16QAM	21.96	-3.62	18.34	33.01	PASS
Band7	20	20850	50	#0	16QAM	20.88	-3.62	17.26	33.01	PASS
Band7	20	20850	50	#Mid	16QAM	20.96	-3.62	17.34	33.01	PASS
Band7	20	20850	50	#Max	16QAM	20.92	-3.62	17.30	33.01	PASS
Band7	20	20850	100	#0	16QAM	20.94	-3.62	17.32	33.01	PASS
Band7	20	21100	1	#0	QPSK	22.59	-3.62	18.97	33.01	PASS
Band7	20	21100	1	#Mid	QPSK	22.88	-3.62	19.26	33.01	PASS
Band7	20	21100	1	#Max	QPSK	22.60	-3.62	18.98	33.01	PASS
Band7	20	21100	50	#0	QPSK	21.81	-3.62	18.19	33.01	PASS
Band7	20	21100	50	#Mid	QPSK	21.89	-3.62	18.27	33.01	PASS
Band7	20	21100	50	#Max	QPSK	21.76	-3.62	18.14	33.01	PASS
Band7	20	21100	100	#0	QPSK	21.82	-3.62	18.20	33.01	PASS
Band7	20	21100	1	#0	16QAM	21.86	-3.62	18.24	33.01	PASS
Band7	20	21100	1	#Mid	16QAM	22.20	-3.62	18.58	33.01	PASS
Band7	20	21100	1	#Max	16QAM	21.93	-3.62	18.31	33.01	PASS
Band7	20	21100	50	#0	16QAM	20.87	-3.62	17.25	33.01	PASS
Band7	20	21100	50	#Mid	16QAM	20.90	-3.62	17.28	33.01	PASS
Band7	20	21100	50	#Max	16QAM	20.86	-3.62	17.24	33.01	PASS
Band7	20	21100	100	#0	16QAM	20.82	-3.62	17.20	33.01	PASS
Band7	20	21350	1	#0	QPSK	22.57	-3.62	18.95	33.01	PASS
Band7	20	21350	1	#Mid	QPSK	22.83	-3.62	19.21	33.01	PASS
Band7	20	21350	1	#Max	QPSK	22.45	-3.62	18.83	33.01	PASS
Band7	20	21350	50	#0	QPSK	21.73	-3.62	18.11	33.01	PASS
Band7	20	21350	50	#Mid	QPSK	21.77	-3.62	18.15	33.01	PASS
Band7	20	21350	50	#Max	QPSK	21.80	-3.62	18.18	33.01	PASS
Band7	20	21350	100	#0	QPSK	21.81	-3.62	18.19	33.01	PASS
Band7	20	21350	1	#0	16QAM	21.96	-3.62	18.34	33.01	PASS
Band7	20	21350	1	#Mid	16QAM	22.16	-3.62	18.54	33.01	PASS
Band7	20	21350	1	#Max	16QAM	21.82	-3.62	18.20	33.01	PASS
Band7	20	21350	50	#0	16QAM	20.81	-3.62	17.19	33.01	PASS
Band7	20	21350	50	#Mid	16QAM	20.85	-3.62	17.23	33.01	PASS
Band7	20	21350	50	#Max	16QAM	20.87	-3.62	17.25	33.01	PASS
Band7	20	21350	100	#0	16QAM	20.79	-3.62	17.17	33.01	PASS

Band	Bandwidth (MHz)	UL Channel	RB Size	RB Position	Modulation	Power (dBm)	Gain (dB)	EIRP (dBm)	EIRP Limit (dBm)	Verdict
Band41	5	39675	1	#0	QPSK	23.32	0.32	23.64	33.01	PASS
Band41	5	39675	1	#Mid	QPSK	23.57	0.32	23.89	33.01	PASS
Band41	5	39675	1	#Max	QPSK	23.38	0.32	23.70	33.01	PASS
Band41	5	39675	12	#0	QPSK	22.41	0.32	22.73	33.01	PASS
Band41	5	39675	12	#Mid	QPSK	22.45	0.32	22.77	33.01	PASS
Band41	5	39675	12	#Max	QPSK	22.45	0.32	22.77	33.01	PASS
Band41	5	39675	25	#0	QPSK	22.40	0.32	22.72	33.01	PASS
Band41	5	39675	1	#0	16QAM	23.02	0.32	23.34	33.01	PASS
Band41	5	39675	1	#Mid	16QAM	23.23	0.32	23.55	33.01	PASS
Band41	5	39675	1	#Max	16QAM	23.00	0.32	23.32	33.01	PASS
Band41	5	39675	12	#0	16QAM	21.37	0.32	21.69	33.01	PASS
Band41	5	39675	12	#Mid	16QAM	21.47	0.32	21.79	33.01	PASS
Band41	5	39675	12	#Max	16QAM	21.44	0.32	21.76	33.01	PASS
Band41	5	39675	25	#0	16QAM	21.42	0.32	21.74	33.01	PASS
Band41	5	40620	1	#0	QPSK	23.01	0.32	23.33	33.01	PASS
Band41	5	40620	1	#Mid	QPSK	23.22	0.32	23.54	33.01	PASS
Band41	5	40620	1	#Max	QPSK	22.94	0.32	23.26	33.01	PASS
Band41	5	40620	12	#0	QPSK	21.96	0.32	22.28	33.01	PASS
Band41	5	40620	12	#Mid	QPSK	22.08	0.32	22.40	33.01	PASS
Band41	5	40620	12	#Max	QPSK	21.96	0.32	22.28	33.01	PASS
Band41	5	40620	25	#0	QPSK	22.02	0.32	22.34	33.01	PASS
Band41	5	40620	1	#0	16QAM	22.33	0.32	22.65	33.01	PASS
Band41	5	40620	1	#Mid	16QAM	22.51	0.32	22.83	33.01	PASS
Band41	5	40620	1	#Max	16QAM	22.24	0.32	22.56	33.01	PASS
Band41	5	40620	12	#0	16QAM	20.99	0.32	21.31	33.01	PASS
Band41	5	40620	12	#Mid	16QAM	21.04	0.32	21.36	33.01	PASS
Band41	5	40620	12	#Max	16QAM	20.99	0.32	21.31	33.01	PASS
Band41	5	40620	25	#0	16QAM	21.10	0.32	21.42	33.01	PASS
Band41	5	41565	1	#0	QPSK	21.42	0.32	21.74	33.01	PASS
Band41	5	41565	1	#Mid	QPSK	21.71	0.32	22.03	33.01	PASS
Band41	5	41565	1	#Max	QPSK	21.48	0.32	21.80	33.01	PASS
Band41	5	41565	12	#0	QPSK	20.58	0.32	20.90	33.01	PASS
Band41	5	41565	12	#Mid	QPSK	20.61	0.32	20.93	33.01	PASS
Band41	5	41565	12	#Max	QPSK	20.54	0.32	20.86	33.01	PASS
Band41	5	41565	25	#0	QPSK	20.55	0.32	20.87	33.01	PASS
Band41	5	41565	1	#0	16QAM	20.80	0.32	21.12	33.01	PASS
Band41	5	41565	1	#Mid	16QAM	21.10	0.32	21.42	33.01	PASS
Band41	5	41565	1	#Max	16QAM	20.89	0.32	21.21	33.01	PASS
Band41	5	41565	12	#0	16QAM	19.56	0.32	19.88	33.01	PASS
Band41	5	41565	12	#Mid	16QAM	19.61	0.32	19.93	33.01	PASS
Band41	5	41565	12	#Max	16QAM	19.54	0.32	19.86	33.01	PASS
Band41	5	41565	25	#0	16QAM	19.50	0.32	19.82	33.01	PASS
Band41	10	39700	1	#0	QPSK	23.41	0.32	23.73	33.01	PASS
Band41	10	39700	1	#Mid	QPSK	23.52	0.32	23.84	33.01	PASS
Band41	10	39700	1	#Max	QPSK	23.47	0.32	23.79	33.01	PASS
Band41	10	39700	25	#0	QPSK	22.45	0.32	22.77	33.01	PASS
Band41	10	39700	25	#Mid	QPSK	22.45	0.32	22.77	33.01	PASS
Band41	10	39700	25	#Max	QPSK	22.51	0.32	22.83	33.01	PASS
Band41	10	39700	50	#0	QPSK	22.49	0.32	22.81	33.01	PASS
Band41	10	39700	1	#0	16QAM	22.90	0.32	23.22	33.01	PASS
Band41	10	39700	1	#Mid	16QAM	23.04	0.32	23.36	33.01	PASS
Band41	10	39700	1	#Max	16QAM	23.02	0.32	23.34	33.01	PASS
Band41	10	39700	25	#0	16QAM	21.50	0.32	21.82	33.01	PASS
Band41	10	39700	25	#Mid	16QAM	21.51	0.32	21.83	33.01	PASS
Band41	10	39700	25	#Max	16QAM	21.57	0.32	21.89	33.01	PASS
Band41	10	39700	50	#0	16QAM	21.49	0.32	21.81	33.01	PASS
Band41	10	40620	1	#0	QPSK	23.15	0.32	23.47	33.01	PASS
Band41	10	40620	1	#Mid	QPSK	23.16	0.32	23.48	33.01	PASS
Band41	10	40620	1	#Max	QPSK	23.01	0.32	23.33	33.01	PASS

Band41	10	40620	25	#0	QPSK	22.18	0.32	22.50	33.01	PASS
Band41	10	40620	25	#Mid	QPSK	22.07	0.32	22.39	33.01	PASS
Band41	10	40620	25	#Max	QPSK	22.02	0.32	22.34	33.01	PASS
Band41	10	40620	50	#0	QPSK	22.11	0.32	22.43	33.01	PASS
Band41	10	40620	1	#0	16QAM	22.31	0.32	22.63	33.01	PASS
Band41	10	40620	1	#Mid	16QAM	22.33	0.32	22.65	33.01	PASS
Band41	10	40620	1	#Max	16QAM	22.11	0.32	22.43	33.01	PASS
Band41	10	40620	25	#0	16QAM	21.21	0.32	21.53	33.01	PASS
Band41	10	40620	25	#Mid	16QAM	21.11	0.32	21.43	33.01	PASS
Band41	10	40620	25	#Max	16QAM	21.09	0.32	21.41	33.01	PASS
Band41	10	40620	50	#0	16QAM	21.19	0.32	21.51	33.01	PASS
Band41	10	41540	1	#0	QPSK	21.58	0.32	21.90	33.01	PASS
Band41	10	41540	1	#Mid	QPSK	21.68	0.32	22.00	33.01	PASS
Band41	10	41540	1	#Max	QPSK	21.63	0.32	21.95	33.01	PASS
Band41	10	41540	25	#0	QPSK	20.66	0.32	20.98	33.01	PASS
Band41	10	41540	25	#Mid	QPSK	20.57	0.32	20.89	33.01	PASS
Band41	10	41540	25	#Max	QPSK	20.52	0.32	20.84	33.01	PASS
Band41	10	41540	50	#0	QPSK	20.58	0.32	20.90	33.01	PASS
Band41	10	41540	1	#0	16QAM	20.61	0.32	20.93	33.01	PASS
Band41	10	41540	1	#Mid	16QAM	20.67	0.32	20.99	33.01	PASS
Band41	10	41540	1	#Max	16QAM	20.60	0.32	20.92	33.01	PASS
Band41	10	41540	25	#0	16QAM	19.66	0.32	19.98	33.01	PASS
Band41	10	41540	25	#Mid	16QAM	19.56	0.32	19.88	33.01	PASS
Band41	10	41540	25	#Max	16QAM	19.52	0.32	19.84	33.01	PASS
Band41	10	41540	50	#0	16QAM	19.58	0.32	19.90	33.01	PASS
Band41	15	39725	1	#0	QPSK	23.30	0.32	23.62	33.01	PASS
Band41	15	39725	1	#Mid	QPSK	23.68	0.32	24.00	33.01	PASS
Band41	15	39725	1	#Max	QPSK	23.37	0.32	23.69	33.01	PASS
Band41	15	39725	36	#0	QPSK	22.44	0.32	22.76	33.01	PASS
Band41	15	39725	36	#Mid	QPSK	22.48	0.32	22.80	33.01	PASS
Band41	15	39725	36	#Max	QPSK	22.56	0.32	22.88	33.01	PASS
Band41	15	39725	75	#0	QPSK	22.47	0.32	22.79	33.01	PASS
Band41	15	39725	1	#0	16QAM	22.83	0.32	23.15	33.01	PASS
Band41	15	39725	1	#Mid	16QAM	23.18	0.32	23.50	33.01	PASS
Band41	15	39725	1	#Max	16QAM	22.91	0.32	23.23	33.01	PASS
Band41	15	39725	36	#0	16QAM	21.45	0.32	21.77	33.01	PASS
Band41	15	39725	36	#Mid	16QAM	21.52	0.32	21.84	33.01	PASS
Band41	15	39725	36	#Max	16QAM	21.57	0.32	21.89	33.01	PASS
Band41	15	39725	75	#0	16QAM	21.47	0.32	21.79	33.01	PASS
Band41	15	40620	1	#0	QPSK	23.13	0.32	23.45	33.01	PASS
Band41	15	40620	1	#Mid	QPSK	23.30	0.32	23.62	33.01	PASS
Band41	15	40620	1	#Max	QPSK	22.85	0.32	23.17	33.01	PASS
Band41	15	40620	36	#0	QPSK	22.13	0.32	22.45	33.01	PASS
Band41	15	40620	36	#Mid	QPSK	22.07	0.32	22.39	33.01	PASS
Band41	15	40620	36	#Max	QPSK	22.04	0.32	22.36	33.01	PASS
Band41	15	40620	75	#0	QPSK	22.07	0.32	22.39	33.01	PASS
Band41	15	40620	1	#0	16QAM	22.28	0.32	22.60	33.01	PASS
Band41	15	40620	1	#Mid	16QAM	22.45	0.32	22.77	33.01	PASS
Band41	15	40620	1	#Max	16QAM	22.03	0.32	22.35	33.01	PASS
Band41	15	40620	36	#0	16QAM	21.20	0.32	21.52	33.01	PASS
Band41	15	40620	36	#Mid	16QAM	21.13	0.32	21.45	33.01	PASS
Band41	15	40620	36	#Max	16QAM	21.09	0.32	21.41	33.01	PASS
Band41	15	40620	75	#0	16QAM	21.13	0.32	21.45	33.01	PASS
Band41	15	41515	1	#0	QPSK	21.58	0.32	21.90	33.01	PASS
Band41	15	41515	1	#Mid	QPSK	21.87	0.32	22.19	33.01	PASS
Band41	15	41515	1	#Max	QPSK	21.61	0.32	21.93	33.01	PASS
Band41	15	41515	36	#0	QPSK	20.59	0.32	20.91	33.01	PASS
Band41	15	41515	36	#Mid	QPSK	20.55	0.32	20.87	33.01	PASS
Band41	15	41515	36	#Max	QPSK	20.53	0.32	20.85	33.01	PASS
Band41	15	41515	75	#0	QPSK	20.57	0.32	20.89	33.01	PASS
Band41	15	41515	1	#0	16QAM	20.76	0.32	21.08	33.01	PASS



Band41	15	41515	1	#Mid	16QAM	21.03	0.32	21.35	33.01	PASS
Band41	15	41515	1	#Max	16QAM	20.79	0.32	21.11	33.01	PASS
Band41	15	41515	36	#0	16QAM	19.53	0.32	19.85	33.01	PASS
Band41	15	41515	36	#Mid	16QAM	19.52	0.32	19.84	33.01	PASS
Band41	15	41515	36	#Max	16QAM	19.50	0.32	19.82	33.01	PASS
Band41	15	41515	75	#0	16QAM	19.57	0.32	19.89	33.01	PASS
Band41	20	39750	1	#0	QPSK	23.20	0.32	23.52	33.01	PASS
Band41	20	39750	1	#Mid	QPSK	23.65	0.32	23.97	33.01	PASS
Band41	20	39750	1	#Max	QPSK	23.25	0.32	23.57	33.01	PASS
Band41	20	39750	50	#0	QPSK	22.33	0.32	22.65	33.01	PASS
Band41	20	39750	50	#Mid	QPSK	22.49	0.32	22.81	33.01	PASS
Band41	20	39750	50	#Max	QPSK	22.56	0.32	22.88	33.01	PASS
Band41	20	39750	100	#0	QPSK	22.46	0.32	22.78	33.01	PASS
Band41	20	39750	1	#0	16QAM	22.40	0.32	22.72	33.01	PASS
Band41	20	39750	1	#Mid	16QAM	22.86	0.32	23.18	33.01	PASS
Band41	20	39750	1	#Max	16QAM	22.44	0.32	22.76	33.01	PASS
Band41	20	39750	50	#0	16QAM	21.43	0.32	21.75	33.01	PASS
Band41	20	39750	50	#Mid	16QAM	21.53	0.32	21.85	33.01	PASS
Band41	20	39750	50	#Max	16QAM	21.62	0.32	21.94	33.01	PASS
Band41	20	39750	100	#0	16QAM	21.48	0.32	21.80	33.01	PASS
Band41	20	40620	1	#0	QPSK	22.97	0.32	23.29	33.01	PASS
Band41	20	40620	1	#Mid	QPSK	23.21	0.32	23.53	33.01	PASS
Band41	20	40620	1	#Max	QPSK	22.72	0.32	23.04	33.01	PASS
Band41	20	40620	50	#0	QPSK	22.15	0.32	22.47	33.01	PASS
Band41	20	40620	50	#Mid	QPSK	22.07	0.32	22.39	33.01	PASS
Band41	20	40620	50	#Max	QPSK	22.01	0.32	22.33	33.01	PASS
Band41	20	40620	100	#0	QPSK	22.11	0.32	22.43	33.01	PASS
Band41	20	40620	1	#0	16QAM	22.30	0.32	22.62	33.01	PASS
Band41	20	40620	1	#Mid	16QAM	22.50	0.32	22.82	33.01	PASS
Band41	20	40620	1	#Max	16QAM	22.01	0.32	22.33	33.01	PASS
Band41	20	40620	50	#0	16QAM	21.25	0.32	21.57	33.01	PASS
Band41	20	40620	50	#Mid	16QAM	21.22	0.32	21.54	33.01	PASS
Band41	20	40620	50	#Max	16QAM	21.13	0.32	21.45	33.01	PASS
Band41	20	40620	100	#0	16QAM	21.16	0.32	21.48	33.01	PASS
Band41	20	41490	1	#0	QPSK	21.41	0.32	21.73	33.01	PASS
Band41	20	41490	1	#Mid	QPSK	21.76	0.32	22.08	33.01	PASS
Band41	20	41490	1	#Max	QPSK	21.45	0.32	21.77	33.01	PASS
Band41	20	41490	50	#0	QPSK	20.62	0.32	20.94	33.01	PASS
Band41	20	41490	50	#Mid	QPSK	20.57	0.32	20.89	33.01	PASS
Band41	20	41490	50	#Max	QPSK	20.41	0.32	20.73	33.01	PASS
Band41	20	41490	100	#0	QPSK	20.51	0.32	20.83	33.01	PASS
Band41	20	41490	1	#0	16QAM	20.62	0.32	20.94	33.01	PASS
Band41	20	41490	1	#Mid	16QAM	20.99	0.32	21.31	33.01	PASS
Band41	20	41490	1	#Max	16QAM	20.66	0.32	20.98	33.01	PASS
Band41	20	41490	50	#0	16QAM	19.58	0.32	19.90	33.01	PASS
Band41	20	41490	50	#Mid	16QAM	19.55	0.32	19.87	33.01	PASS
Band41	20	41490	50	#Max	16QAM	19.39	0.32	19.71	33.01	PASS
Band41	20	41490	100	#0	16QAM	19.52	0.32	19.84	33.01	PASS

Frequency stability

LTE Band 2 (QPSK) / 1880MHz / BW20M					
Temperature (°C)	Voltage (Volt)	Freq. Dev. (Hz)	Freq. Dev. (ppm)	Limit	Result
	50	Normal Voltage	4.48		
40	-4.37		-0.002		
30	4.48		0.002		
20	-10.60		-0.006		
10	-4.53		-0.002		
0	4.20		0.002		
-10	4.49		0.002		
-20	-4.70		-0.003		
-30	4.64		0.002		
20	Maximum Voltage		-6.27	-0.003	
20	BEP	2.10	0.001		

LTE Band 2 (16QAM) / 1880MHz / BW20M					
Temperature (°C)	Voltage (Volt)	Freq. Dev. (Hz)	Freq. Dev. (ppm)	Limit	Result
	50	Normal Voltage	-5.32		
40	5.07		0.003		
30	5.06		0.003		
20	-12.29		-0.007		
10	-5.37		-0.003		
0	-5.29		-0.003		
-10	5.39		0.003		
-20	5.61		0.003		
-30	5.33		0.003		
20	Maximum Voltage		-7.60	-0.004	
20	BEP	-7.58	-0.004		

LTE Band 4 (QPSK) / 1733MHz / BW20M					
Temperature (°C)	Voltage (Volt)	Freq. Dev. (Hz)	Freq. Dev. (ppm)	Limit	Result
	50	Normal Voltage	-2.01		
40	-2.46		-0.001		
30	-1.98		-0.001		
20	-6.11		-0.004		
10	-2.19		-0.001		
0	-2.08		-0.001		
-10	2.46		0.001		
-20	-1.96		-0.001		
-30	-2.17		-0.001		
20	Maximum Voltage		-3.24	-0.002	
20	BEP	1.11	0.001		

LTE Band 4 (16QAM) / 1733MHz / BW20M					
Temperature (°C)	Voltage (Volt)	Freq. Dev. (Hz)	Freq. Dev. (ppm)	Limit	Result
	50	Normal Voltage	-0.23		
40	0.19		0.000		
30	-0.20		0.000		
20	-2.12		-0.001		
10	0.22		0.000		
0	-0.18		0.000		
-10	0.51		0.000		
-20	0.42		0.000		
-30	-0.08		0.000		
20	Maximum Voltage		0.20	0.000	
20	BEP	-0.68	0.000		

LTE Band 5 (QPSK) / 836.5MHz / BW10M					
Temperature (°C)	Voltage (Volt)	Freq. Dev. (Hz)	Freq. Dev. (ppm)	Limit	Result
	50	Normal Voltage	3.22		
40	3.32		0.004		
30	3.67		0.004		
20	-8.68		-0.010		
10	-3.32		-0.004		
0	3.29		0.004		
-10	3.76		0.004		
-20	3.24		0.004		
-30	3.66		0.004		
20	Maximum Voltage		-5.35	-0.006	
20	BEP	-5.49	-0.007		

LTE Band 5 (16QAM) / 836.5MHz / BW10M					
Temperature (°C)	Voltage (Volt)	Freq. Dev. (Hz)	Freq. Dev. (ppm)	Limit	Result
	50	Normal Voltage	-1.81		
40	-2.05		-0.002		
30	-1.70		-0.002		
20	-5.58		-0.007		
10	-2.07		-0.002		
0	-2.23		-0.003		
-10	2.03		0.002		
-20	1.86		0.002		
-30	-1.79		-0.002		
20	Maximum Voltage		0.91	0.001	
20	BEP	-3.15	-0.004		

LTE Band 7 (QPSK) / 2535MHz / BW20M					
Temperature (°C)	Voltage (Volt)	Freq. Dev. (Hz)	Freq. Dev. (ppm)	Limit	Result
	50	Normal Voltage	-2.59		
40	-2.75		-0.001		
30	-2.34		-0.001		
20	-6.79		-0.003		
10	-2.41		-0.001		
0	2.33		0.001		
-10	-2.75		-0.001		
-20	-2.35		-0.001		
-30	2.43		0.001		
20	Maximum Voltage		-4.01	-0.002	
20	BEP	-3.95	-0.002		

LTE Band 7 (16QAM) / 2535MHz / BW20M					
Temperature (°C)	Voltage (Volt)	Freq. Dev. (Hz)	Freq. Dev. (ppm)	Limit	Result
	50	Normal Voltage	0.15		
40	-0.08		0.000		
30	-0.34		0.000		
20	-1.56		-0.001		
10	0.30		0.000		
0	-0.14		0.000		
-10	0.10		0.000		
-20	0.01		0.000		
-30	-0.20		0.000		
20	Maximum Voltage		0.11	0.000	
20	BEP	-0.27	0.000		

LTE Band 41 (QPSK) / 2593MHz / BW20M					
Temperature (°C)	Voltage (Volt)	Freq. Dev. (Hz)	Freq. Dev. (ppm)	Limit	Result
	50	Normal Voltage	1.53		
40	-1.84		-0.001		
30	1.55		0.001		
20	-5.29		-0.002		
10	1.61		0.001		
0	-1.77		-0.001		
-10	-1.54		-0.001		
-20	-1.92		-0.001		
-30	-1.63		-0.001		
20	Maximum Voltage		1.01	0.000	
20	BEP	0.94	0.000		

LTE Band 41 (16QAM) / 2593MHz / BW20M					
Temperature (°C)	Voltage (Volt)	Freq. Dev. (Hz)	Freq. Dev. (ppm)	Limit	Result
	50	Normal Voltage	0.88		
40	0.78		0.000		
30	1.08		0.000		
20	-3.48		-0.001		
10	1.11		0.000		
0	0.82		0.000		
-10	0.99		0.000		
-20	-1.16		0.000		
-30	0.85		0.000		
20	Maximum Voltage		-1.24	0.000	
20	BEP	0.54	0.000		

Peak-to-Average Ratio

Band	Bandwidth (MHz)	UL Channel	RB Size	RB Position	Modulation	Result (dB)	high Limit (dB)	Verdict
Band2	1.4	18607	1	#0	QPSK	5.41	13	PASS
Band2	1.4	18607	1	#0	16QAM	6.33	13	PASS
Band2	1.4	18900	1	#0	QPSK	5.41	13	PASS
Band2	1.4	18900	1	#0	16QAM	5.78	13	PASS
Band2	1.4	19193	1	#0	QPSK	5.74	13	PASS
Band2	1.4	19193	1	#0	16QAM	6.39	13	PASS
Band2	3	18615	1	#0	QPSK	5.24	13	PASS
Band2	3	18615	1	#0	16QAM	5.62	13	PASS
Band2	3	18900	1	#0	QPSK	5.72	13	PASS
Band2	3	18900	1	#0	16QAM	6.56	13	PASS
Band2	3	19185	1	#0	QPSK	5.79	13	PASS
Band2	3	19185	1	#0	16QAM	6.53	13	PASS
Band2	5	18625	1	#0	QPSK	5.37	13	PASS
Band2	5	18625	1	#0	16QAM	5.81	13	PASS
Band2	5	18900	1	#0	QPSK	6.16	13	PASS
Band2	5	18900	1	#0	16QAM	6.27	13	PASS
Band2	5	19175	1	#0	QPSK	5.44	13	PASS
Band2	5	19175	1	#0	16QAM	5.96	13	PASS
Band2	10	18650	1	#0	QPSK	5.20	13	PASS
Band2	10	18650	1	#0	16QAM	5.59	13	PASS
Band2	10	18900	1	#0	QPSK	5.68	13	PASS
Band2	10	18900	1	#0	16QAM	6.56	13	PASS
Band2	10	19150	1	#0	QPSK	5.50	13	PASS
Band2	10	19150	1	#0	16QAM	5.92	13	PASS
Band2	15	18675	1	#0	QPSK	5.50	13	PASS
Band2	15	18675	1	#0	16QAM	5.80	13	PASS
Band2	15	18900	1	#0	QPSK	5.43	13	PASS
Band2	15	18900	1	#0	16QAM	6.56	13	PASS
Band2	15	19125	1	#0	QPSK	5.42	13	PASS
Band2	15	19125	1	#0	16QAM	6.32	13	PASS
Band2	20	18700	1	#0	QPSK	5.64	13	PASS
Band2	20	18700	1	#0	16QAM	6.30	13	PASS
Band2	20	18900	1	#0	QPSK	5.26	13	PASS
Band2	20	18900	1	#0	16QAM	5.71	13	PASS
Band2	20	19100	1	#0	QPSK	5.69	13	PASS
Band2	20	19100	1	#0	16QAM	6.13	13	PASS
Band4	1.4	19957	1	#0	QPSK	5.82	13	PASS
Band4	1.4	19957	1	#0	16QAM	6.44	13	PASS
Band4	1.4	20175	1	#0	QPSK	5.12	13	PASS
Band4	1.4	20175	1	#0	16QAM	5.32	13	PASS
Band4	1.4	20393	1	#0	QPSK	5.67	13	PASS
Band4	1.4	20393	1	#0	16QAM	6.26	13	PASS
Band4	3	19965	1	#0	QPSK	5.66	13	PASS
Band4	3	19965	1	#0	16QAM	6.00	13	PASS
Band4	3	20175	1	#0	QPSK	5.34	13	PASS
Band4	3	20175	1	#0	16QAM	5.51	13	PASS
Band4	3	20385	1	#0	QPSK	5.54	13	PASS
Band4	3	20385	1	#0	16QAM	6.04	13	PASS
Band4	5	19975	1	#0	QPSK	6.22	13	PASS
Band4	5	19975	1	#0	16QAM	6.07	13	PASS
Band4	5	20175	1	#0	QPSK	5.26	13	PASS
Band4	5	20175	1	#0	16QAM	5.38	13	PASS
Band4	5	20375	1	#0	QPSK	5.59	13	PASS
Band4	5	20375	1	#0	16QAM	6.03	13	PASS
Band4	10	20000	1	#0	QPSK	5.55	13	PASS
Band4	10	20000	1	#0	16QAM	5.96	13	PASS
Band4	10	20175	1	#0	QPSK	5.55	13	PASS
Band4	10	20175	1	#0	16QAM	6.05	13	PASS
Band4	10	20350	1	#0	QPSK	5.81	13	PASS

Band4	10	20350	1	#0	16QAM	6.33	13	PASS
Band4	15	20025	1	#0	QPSK	6.10	13	PASS
Band4	15	20025	1	#0	16QAM	6.41	13	PASS
Band4	15	20175	1	#0	QPSK	5.77	13	PASS
Band4	15	20175	1	#0	16QAM	6.34	13	PASS
Band4	15	20325	1	#0	QPSK	5.72	13	PASS
Band4	15	20325	1	#0	16QAM	5.95	13	PASS
Band4	20	20050	1	#0	QPSK	5.78	13	PASS
Band4	20	20050	1	#0	16QAM	6.06	13	PASS
Band4	20	20175	1	#0	QPSK	6.08	13	PASS
Band4	20	20175	1	#0	16QAM	6.51	13	PASS
Band4	20	20300	1	#0	QPSK	5.58	13	PASS
Band4	20	20300	1	#0	16QAM	5.93	13	PASS
Band5	1.4	20407	1	#0	QPSK	5.47	13	PASS
Band5	1.4	20407	1	#0	16QAM	6.18	13	PASS
Band5	1.4	20525	1	#0	QPSK	5.24	13	PASS
Band5	1.4	20525	1	#0	16QAM	6.34	13	PASS
Band5	1.4	20643	1	#0	QPSK	4.91	13	PASS
Band5	1.4	20643	1	#0	16QAM	5.59	13	PASS
Band5	3	20415	1	#0	QPSK	5.43	13	PASS
Band5	3	20415	1	#0	16QAM	6.27	13	PASS
Band5	3	20525	1	#0	QPSK	5.15	13	PASS
Band5	3	20525	1	#0	16QAM	5.99	13	PASS
Band5	3	20635	1	#0	QPSK	5.06	13	PASS
Band5	3	20635	1	#0	16QAM	5.69	13	PASS
Band5	5	20425	1	#0	QPSK	5.62	13	PASS
Band5	5	20425	1	#0	16QAM	6.00	13	PASS
Band5	5	20525	1	#0	QPSK	5.06	13	PASS
Band5	5	20525	1	#0	16QAM	5.70	13	PASS
Band5	5	20625	1	#0	QPSK	5.70	13	PASS
Band5	5	20625	1	#0	16QAM	5.99	13	PASS
Band5	10	20450	1	#0	QPSK	5.43	13	PASS
Band5	10	20450	1	#0	16QAM	6.57	13	PASS
Band5	10	20525	1	#0	QPSK	5.22	13	PASS
Band5	10	20525	1	#0	16QAM	5.88	13	PASS
Band5	10	20600	1	#0	QPSK	5.78	13	PASS
Band5	10	20600	1	#0	16QAM	6.29	13	PASS
Band7	5	20775	1	#0	QPSK	4.12	13	PASS
Band7	5	20775	1	#0	16QAM	4.77	13	PASS
Band7	5	21100	1	#0	QPSK	4.26	13	PASS
Band7	5	21100	1	#0	16QAM	4.97	13	PASS
Band7	5	21425	1	#0	QPSK	4.73	13	PASS
Band7	5	21425	1	#0	16QAM	5.38	13	PASS
Band7	10	20800	1	#0	QPSK	4.02	13	PASS
Band7	10	20800	1	#0	16QAM	4.91	13	PASS
Band7	10	21100	1	#0	QPSK	4.16	13	PASS
Band7	10	21100	1	#0	16QAM	4.96	13	PASS
Band7	10	21400	1	#0	QPSK	5.05	13	PASS
Band7	10	21400	1	#0	16QAM	5.84	13	PASS
Band7	15	20825	1	#0	QPSK	4.10	13	PASS
Band7	15	20825	1	#0	16QAM	4.89	13	PASS
Band7	15	21100	1	#0	QPSK	4.60	13	PASS
Band7	15	21100	1	#0	16QAM	5.56	13	PASS
Band7	15	21375	1	#0	QPSK	4.68	13	PASS
Band7	15	21375	1	#0	16QAM	5.45	13	PASS
Band7	20	20850	1	#0	QPSK	4.31	13	PASS
Band7	20	20850	1	#0	16QAM	5.18	13	PASS
Band7	20	21100	1	#0	QPSK	4.94	13	PASS
Band7	20	21100	1	#0	16QAM	5.54	13	PASS
Band7	20	21350	1	#0	QPSK	4.53	13	PASS
Band7	20	21350	1	#0	16QAM	5.33	13	PASS



Band41	5	39675	1	#0	QPSK	9.79	13	PASS
Band41	5	39675	1	#0	16QAM	9.71	13	PASS
Band41	5	40620	1	#0	QPSK	9.61	13	PASS
Band41	5	40620	1	#0	16QAM	9.43	13	PASS
Band41	5	41565	1	#0	QPSK	10.62	13	PASS
Band41	5	41565	1	#0	16QAM	8.48	13	PASS
Band41	10	39700	1	#0	QPSK	11.28	13	PASS
Band41	10	39700	1	#0	16QAM	10.04	13	PASS
Band41	10	40620	1	#0	QPSK	9.34	13	PASS
Band41	10	40620	1	#0	16QAM	10.19	13	PASS
Band41	10	41540	1	#0	QPSK	9.24	13	PASS
Band41	10	41540	1	#0	16QAM	9.85	13	PASS
Band41	15	39725	1	#0	QPSK	9.74	13	PASS
Band41	15	39725	1	#0	16QAM	9.90	13	PASS
Band41	15	40620	1	#0	QPSK	9.12	13	PASS
Band41	15	40620	1	#0	16QAM	10.74	13	PASS
Band41	15	41515	1	#0	QPSK	9.42	13	PASS
Band41	15	41515	1	#0	16QAM	9.94	13	PASS
Band41	20	39750	1	#0	QPSK	9.38	13	PASS
Band41	20	39750	1	#0	16QAM	9.63	13	PASS
Band41	20	40620	1	#0	QPSK	9.19	13	PASS
Band41	20	40620	1	#0	16QAM	9.66	13	PASS
Band41	20	41490	1	#0	QPSK	9.30	13	PASS
Band41	20	41490	1	#0	16QAM	9.50	13	PASS

**Band2 16QAM BW=1.4MHz Channel=18607 RB Size=1 Position=#0**



**Band2 16QAM BW=1.4MHz Channel=18900 RB Size=1 Position=#0**

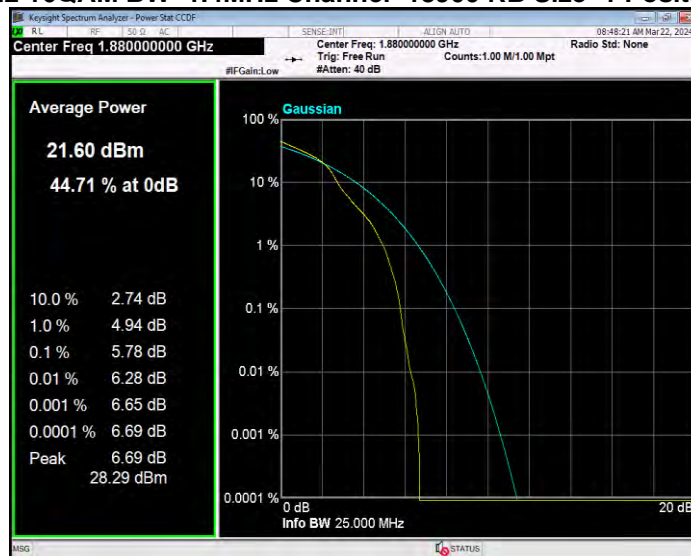

**Band2 16QAM BW=1.4MHz Channel=19193 RB Size=1 Position=#0**

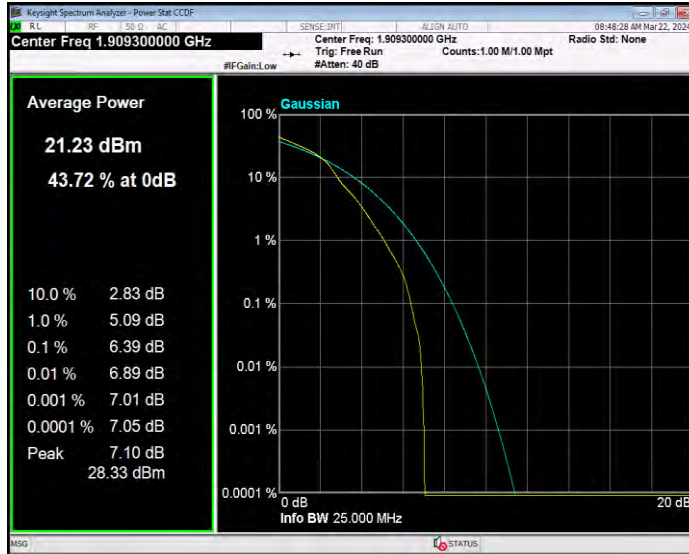

**Band2 16QAM BW=10MHz Channel=18650 RB Size=1 Position=#0**



**Band2 16QAM BW=10MHz Channel=18900 RB Size=1 Position=#0**

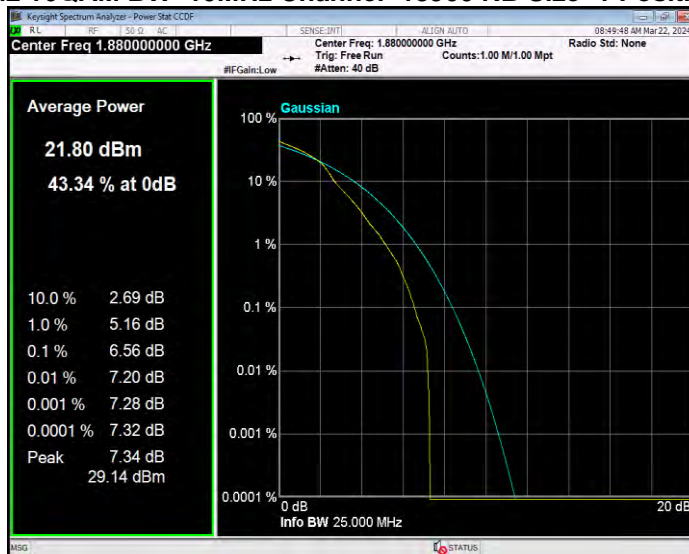

**Band2 16QAM BW=10MHz Channel=19150 RB Size=1 Position=#0**

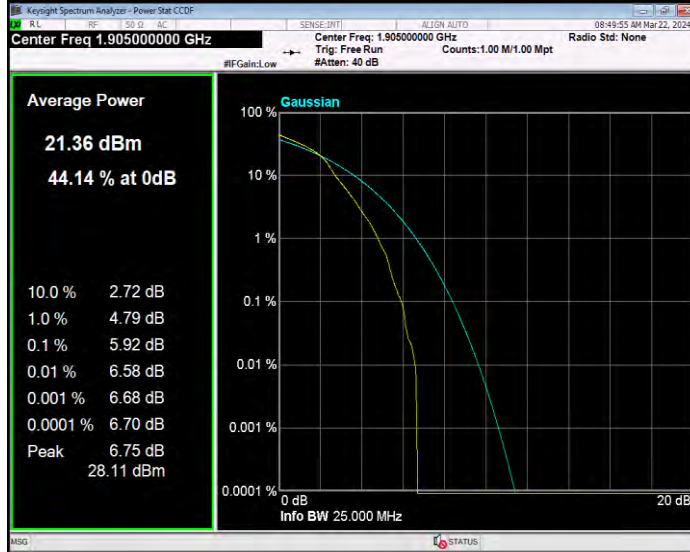

**Band2 16QAM BW=15MHz Channel=18675 RB Size=1 Position=#0**

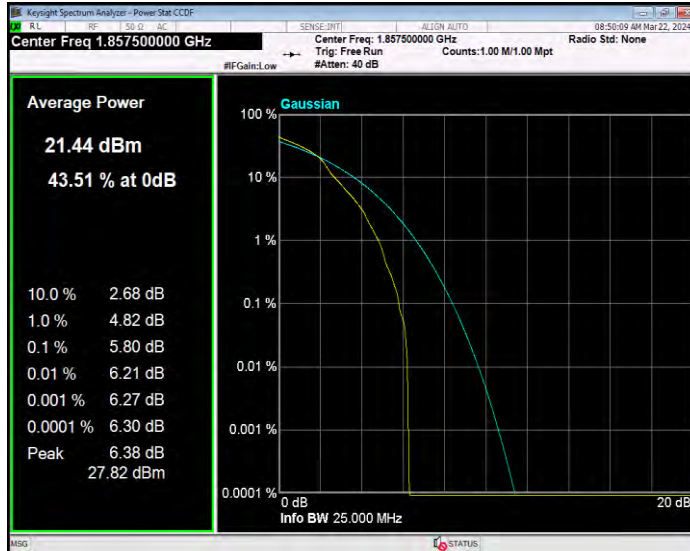

**Band2 16QAM BW=15MHz Channel=18900 RB Size=1 Position=#0**

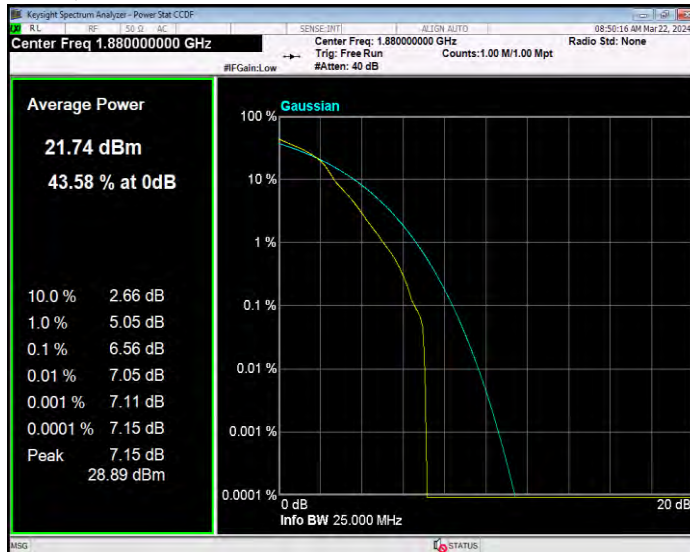

**Band2 16QAM BW=15MHz Channel=19125 RB Size=1 Position=#0**

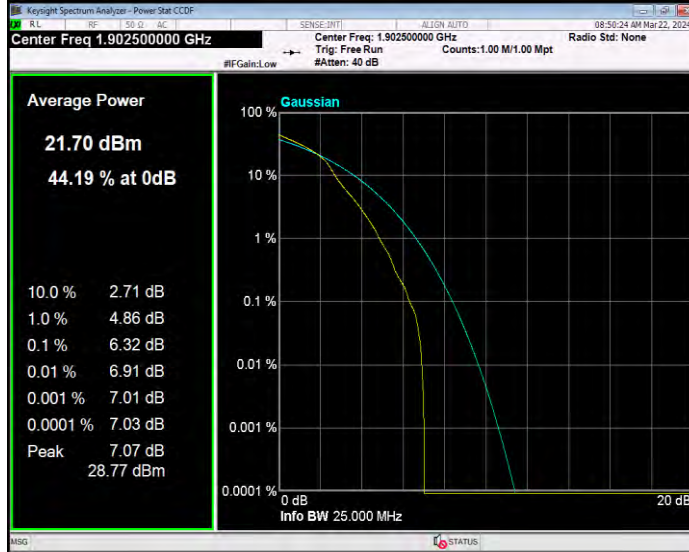

**Band2 16QAM BW=20MHz Channel=18700 RB Size=1 Position=#0**

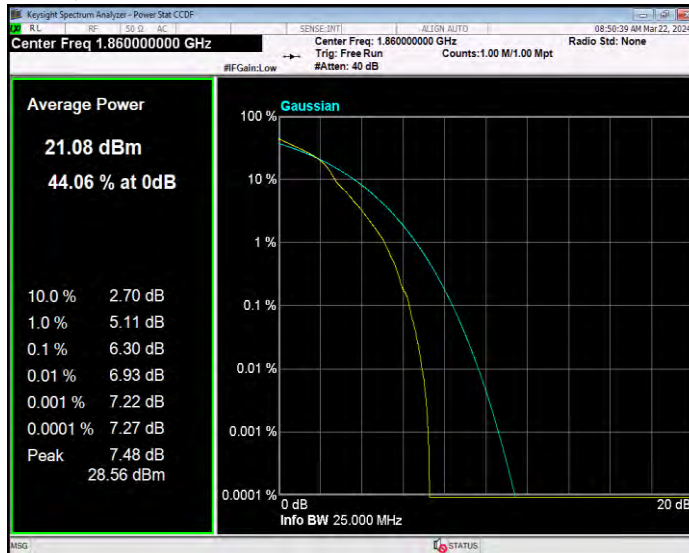

**Band2 16QAM BW=20MHz Channel=18900 RB Size=1 Position=#0**

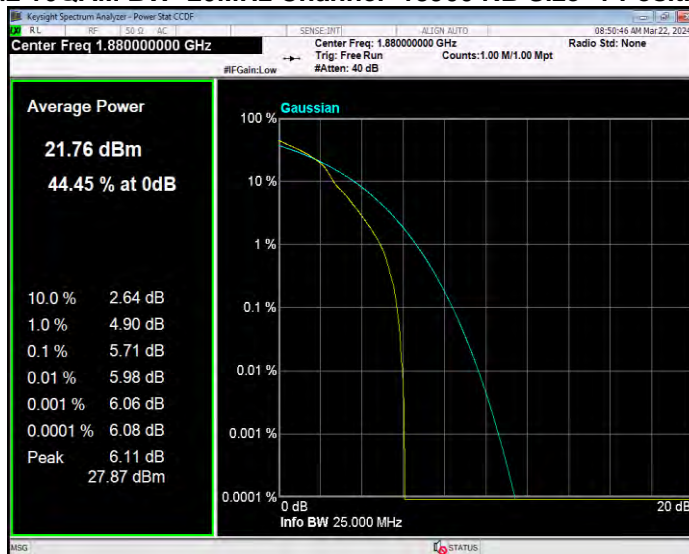

**Band2 16QAM BW=20MHz Channel=19100 RB Size=1 Position=#0**



**Band2 16QAM BW=3MHz Channel=18615 RB Size=1 Position=#0**

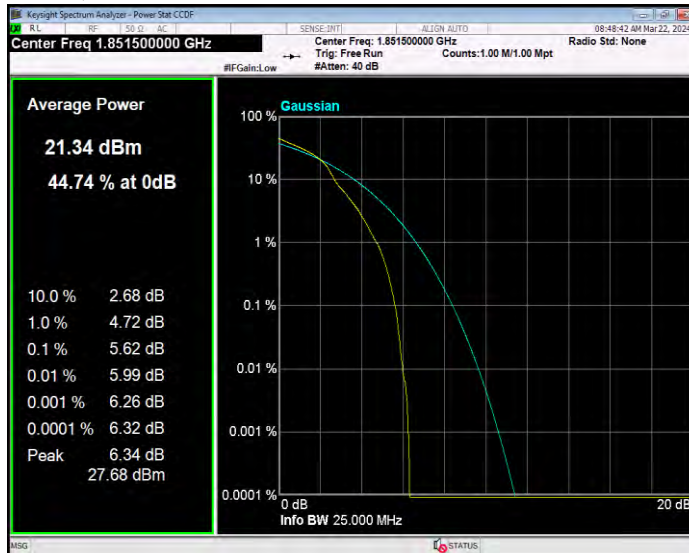

**Band2 16QAM BW=3MHz Channel=18900 RB Size=1 Position=#0**

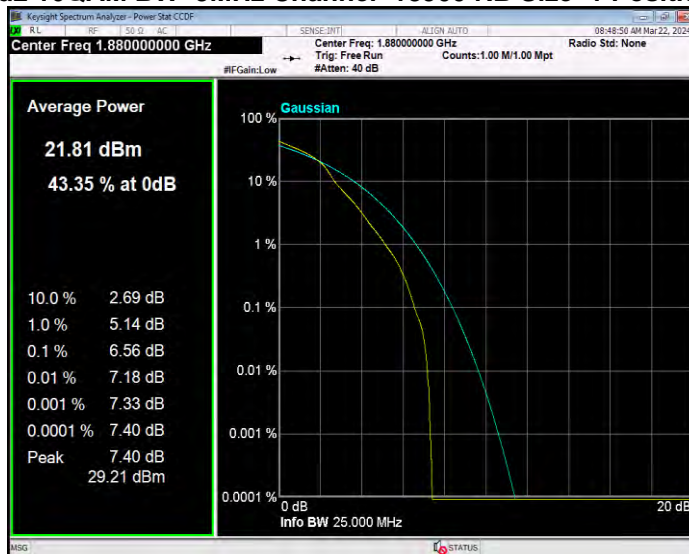

**Band2 16QAM BW=3MHz Channel=19185 RB Size=1 Position=#0**

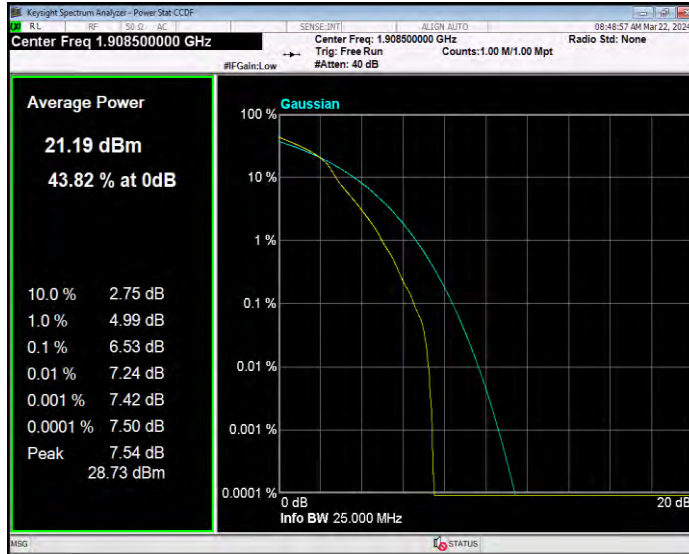

**Band2 16QAM BW=5MHz Channel=18625 RB Size=1 Position=#0**

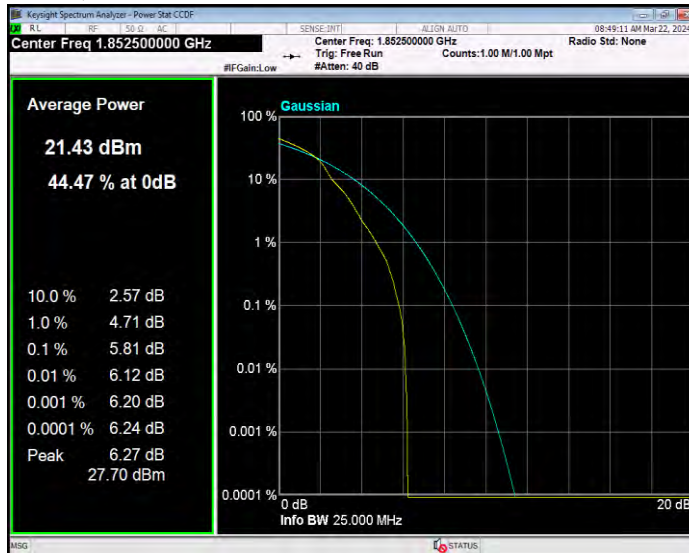

**Band2 16QAM BW=5MHz Channel=18900 RB Size=1 Position=#0**

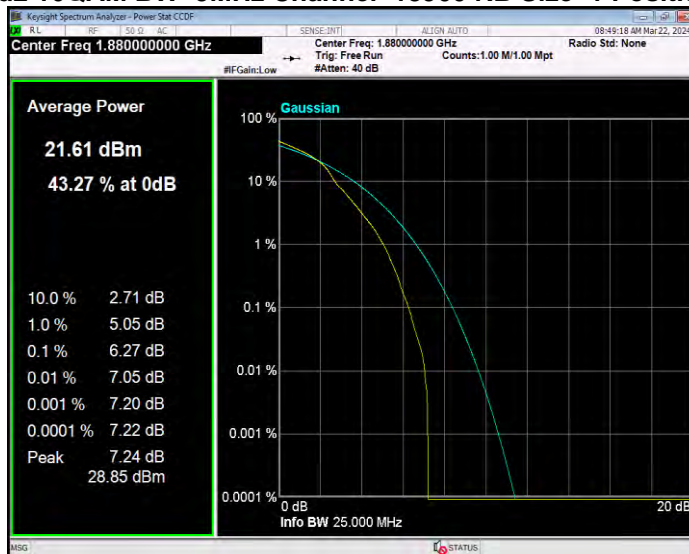

**Band2 16QAM BW=5MHz Channel=19175 RB Size=1 Position=#0**

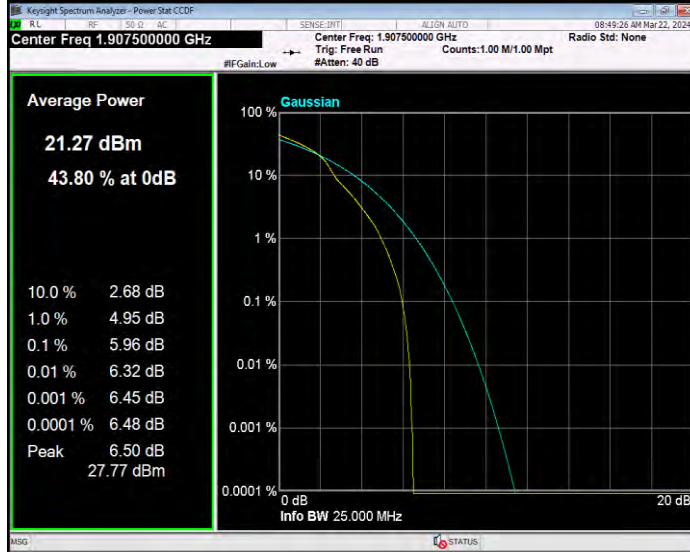

**Band2 QPSK BW=1.4MHz Channel=18607 RB Size=1 Position=#0**

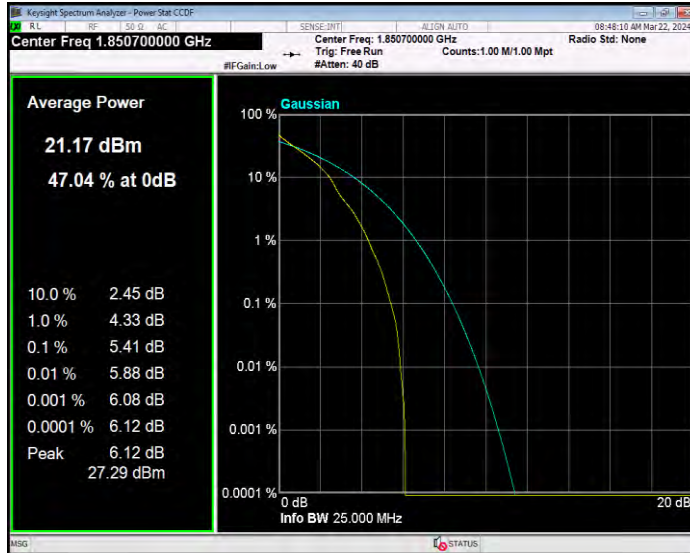

**Band2 QPSK BW=1.4MHz Channel=18900 RB Size=1 Position=#0**

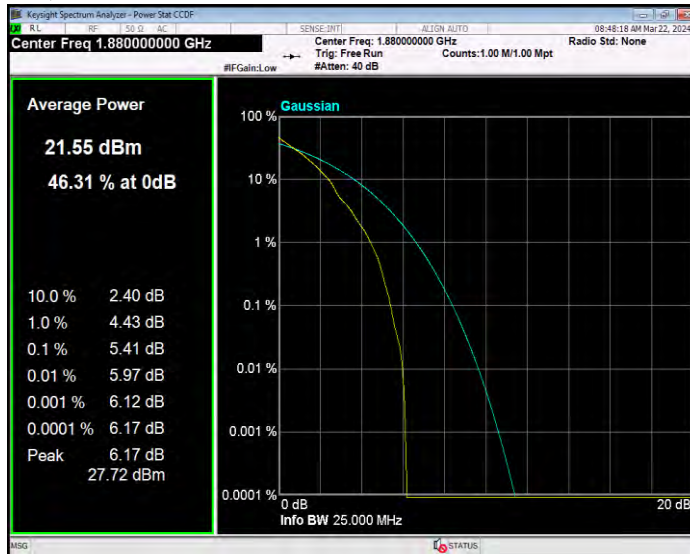

**Band2 QPSK BW=1.4MHz Channel=19193 RB Size=1 Position=#0**

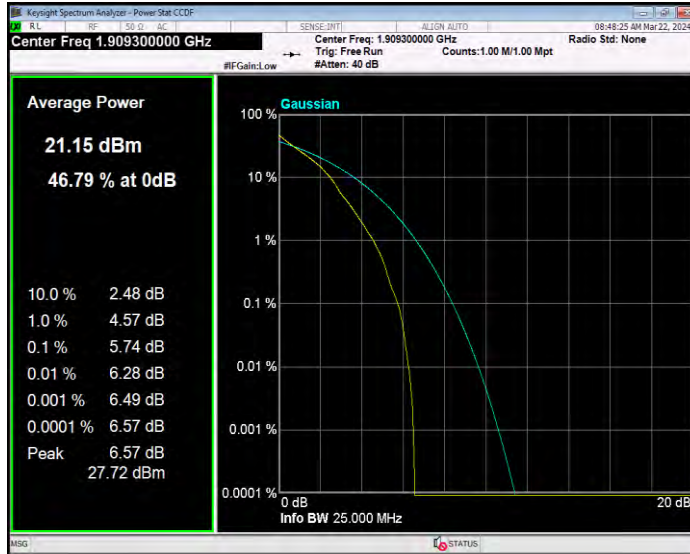

**Band2 QPSK BW=10MHz Channel=18650 RB Size=1 Position=#0**

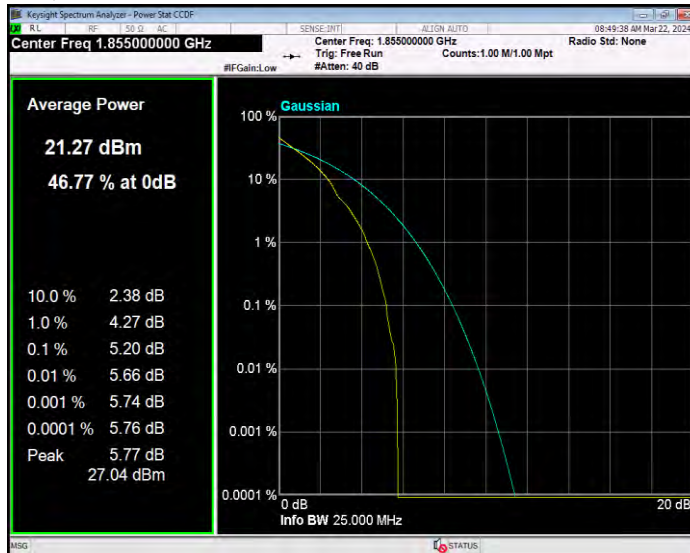

**Band2 QPSK BW=10MHz Channel=18900 RB Size=1 Position=#0**

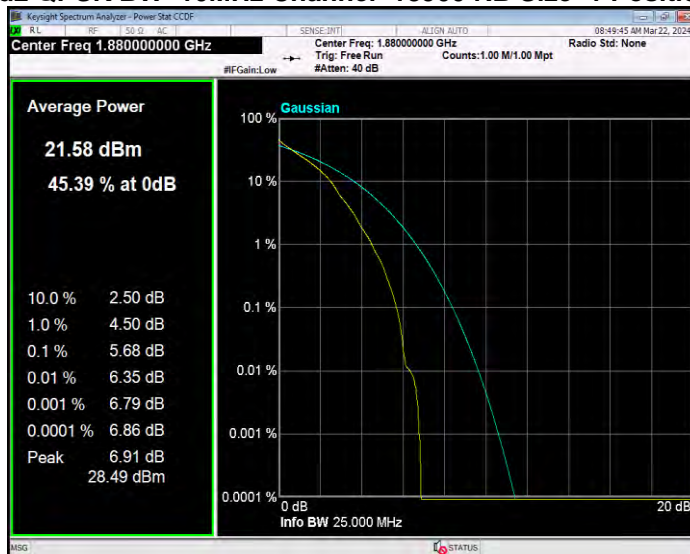



**Band2 QPSK BW=10MHz Channel=19150 RB Size=1 Position=#0**

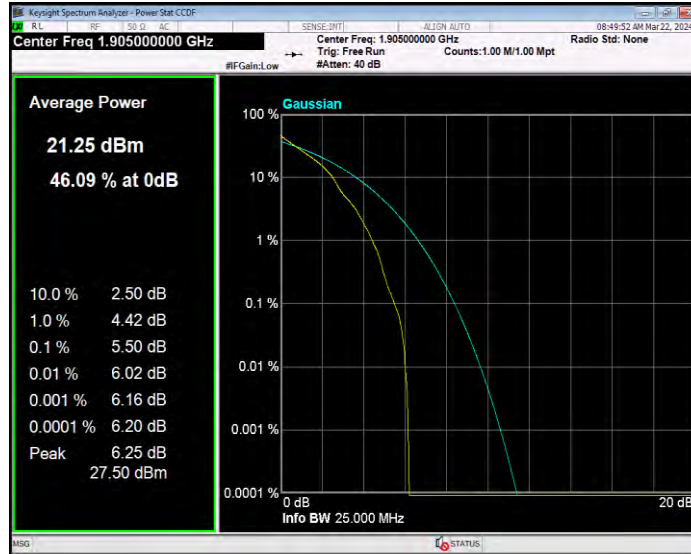

**Band2 QPSK BW=15MHz Channel=18675 RB Size=1 Position=#0**

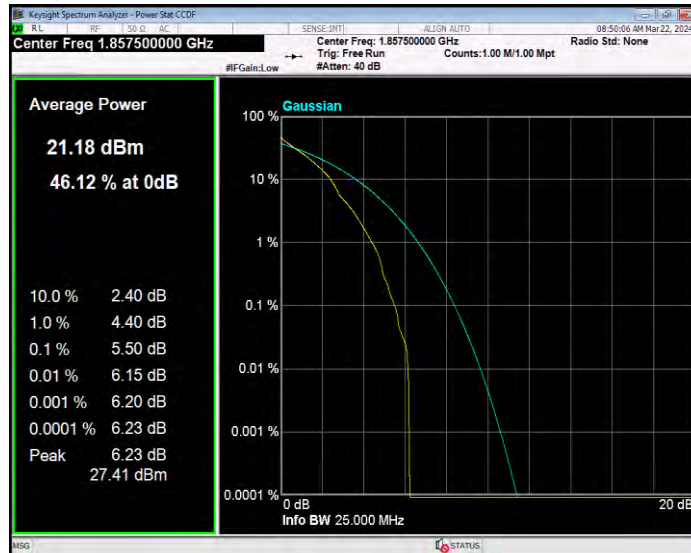

**Band2 QPSK BW=15MHz Channel=18900 RB Size=1 Position=#0**

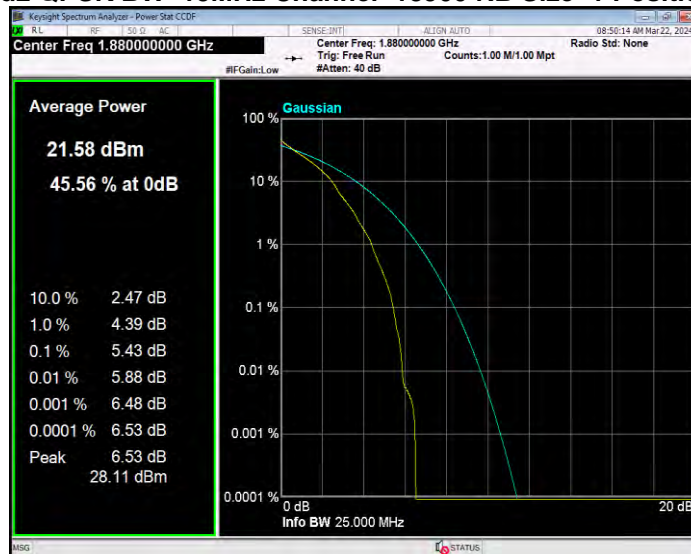

**Band2 QPSK BW=15MHz Channel=19125 RB Size=1 Position=#0**

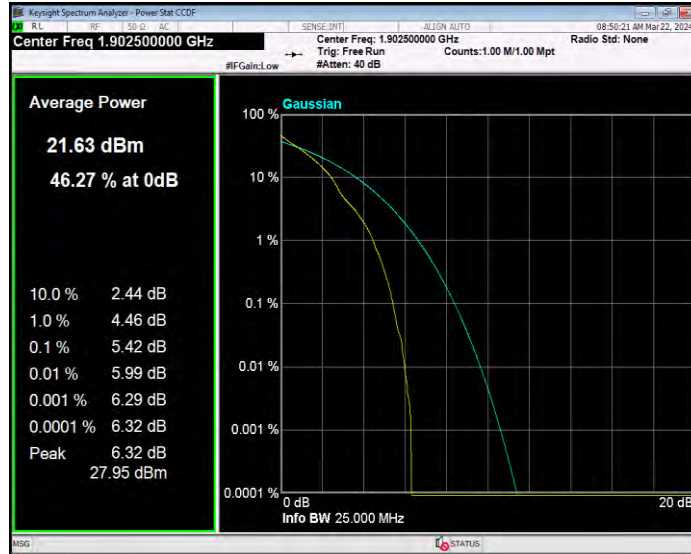

**Band2 QPSK BW=20MHz Channel=18700 RB Size=1 Position=#0**

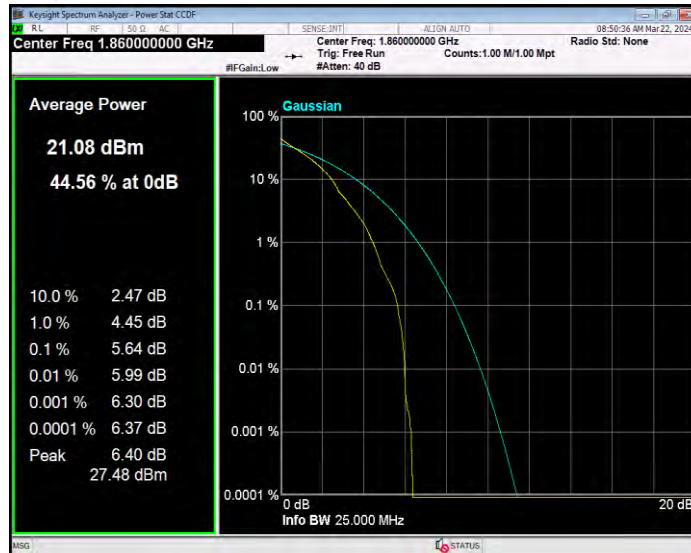

**Band2 QPSK BW=20MHz Channel=18900 RB Size=1 Position=#0**



**Band2 QPSK BW=20MHz Channel=19100 RB Size=1 Position=#0**

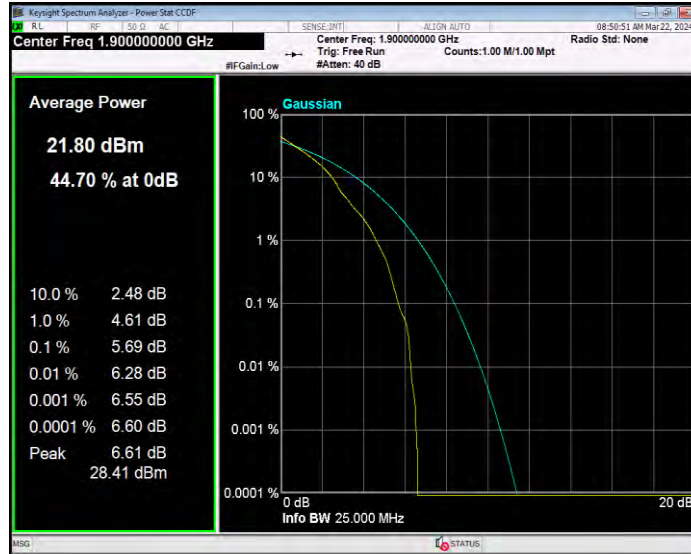

**Band2 QPSK BW=3MHz Channel=18615 RB Size=1 Position=#0**

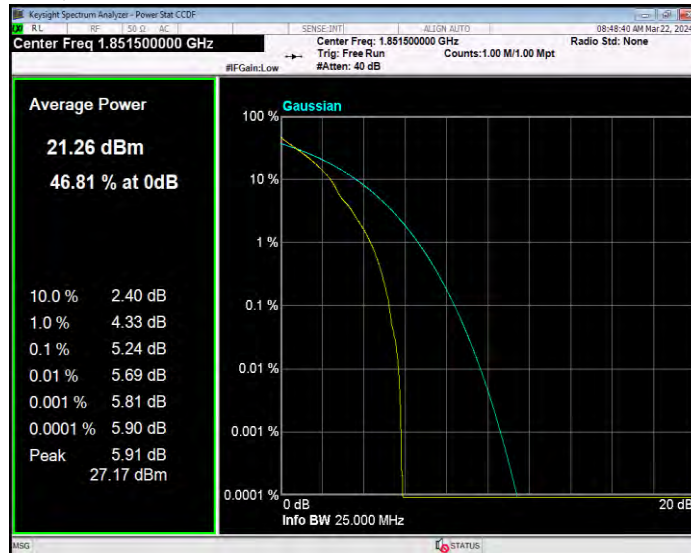

**Band2 QPSK BW=3MHz Channel=18900 RB Size=1 Position=#0**

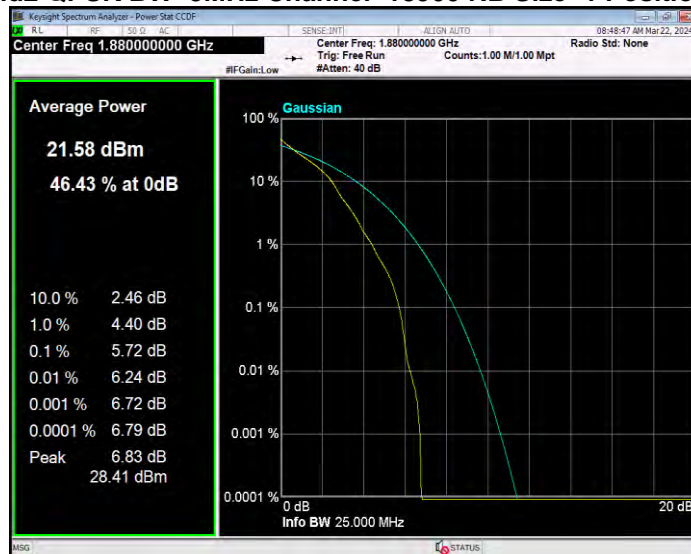

**Band2 QPSK BW=3MHz Channel=19185 RB Size=1 Position=#0**

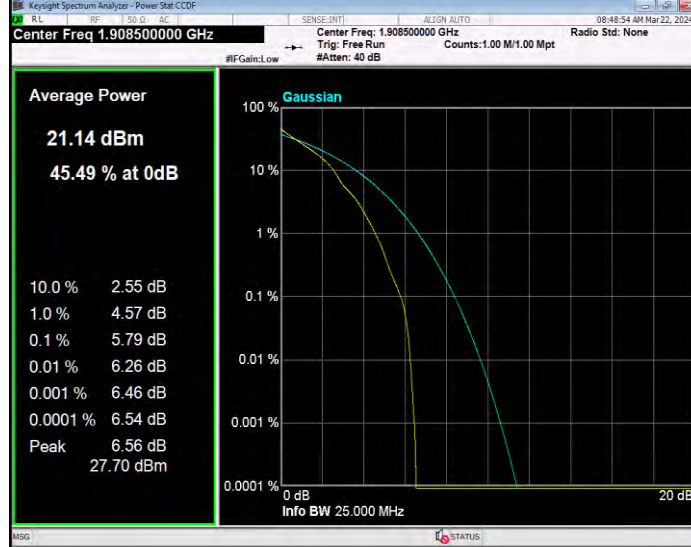

**Band2 QPSK BW=5MHz Channel=18625 RB Size=1 Position=#0**

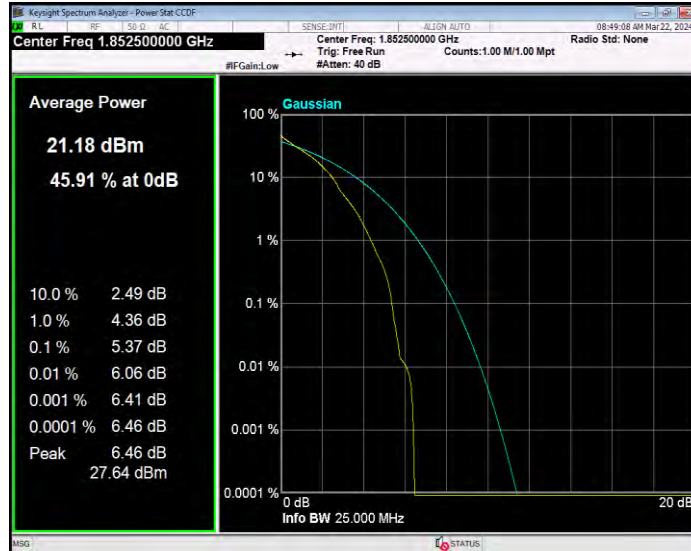

**Band2 QPSK BW=5MHz Channel=18900 RB Size=1 Position=#0**

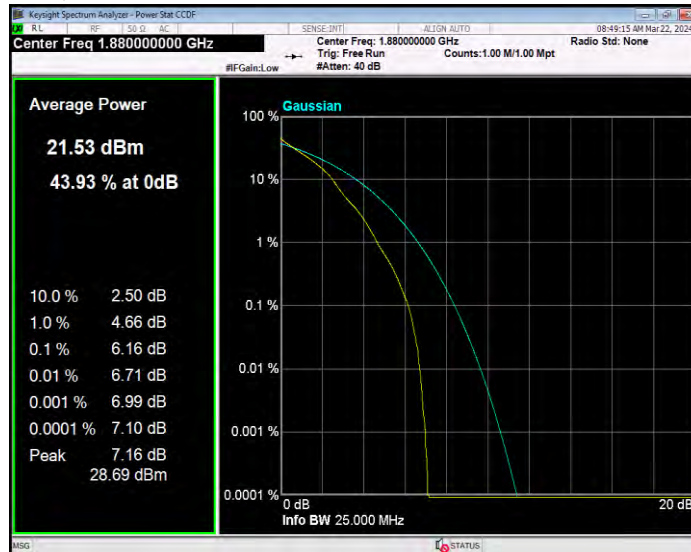

**Band2 QPSK BW=5MHz Channel=19175 RB Size=1 Position=#0**

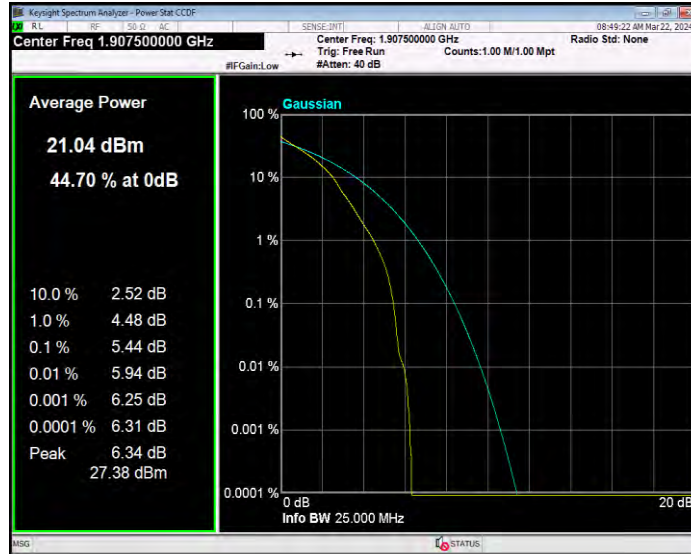

**Band4 16QAM BW=1.4MHz Channel=19957 RB Size=1 Position=#0**

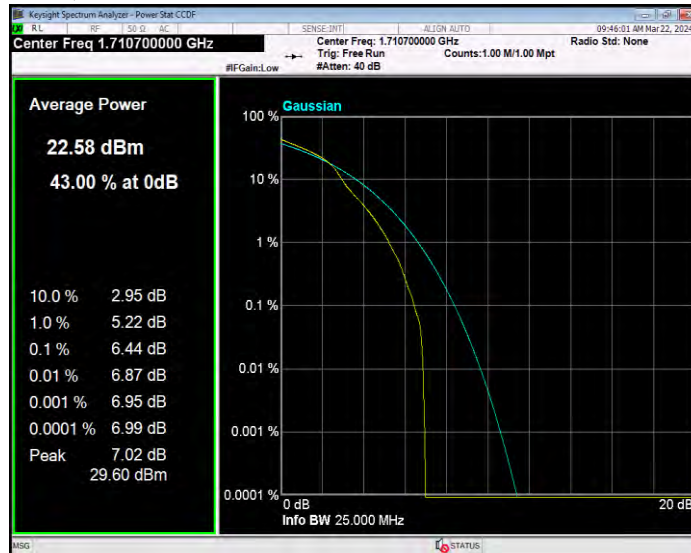

**Band4 16QAM BW=1.4MHz Channel=20175 RB Size=1 Position=#0**



**Band4 16QAM BW=1.4MHz Channel=20393 RB Size=1 Position=#0**

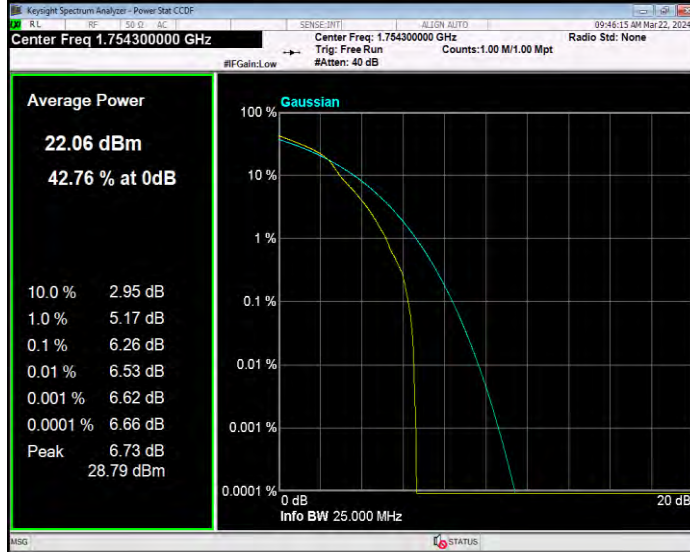

**Band4 16QAM BW=10MHz Channel=20000 RB Size=1 Position=#0**

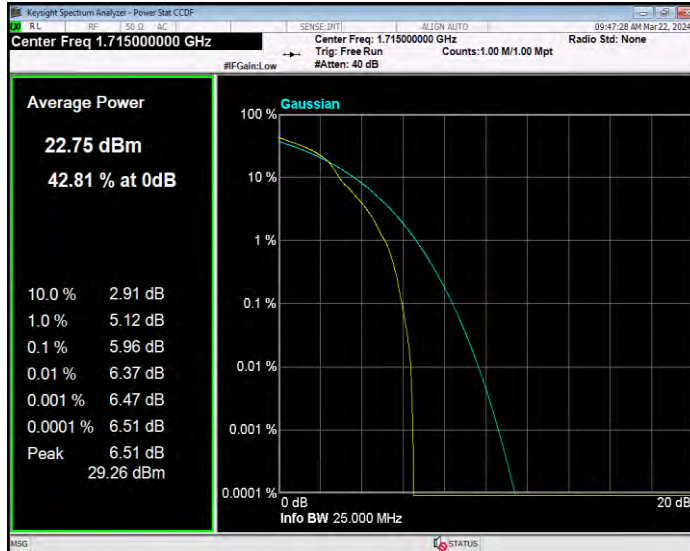

**Band4 16QAM BW=10MHz Channel=20175 RB Size=1 Position=#0**

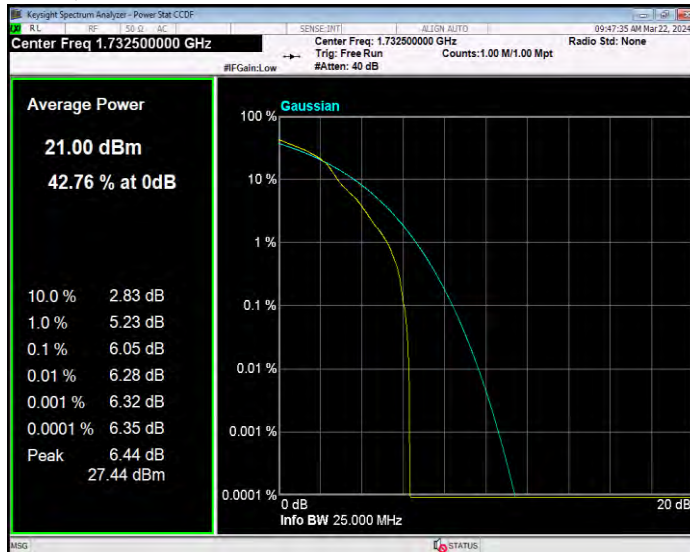

**Band4 16QAM BW=10MHz Channel=20350 RB Size=1 Position=#0**

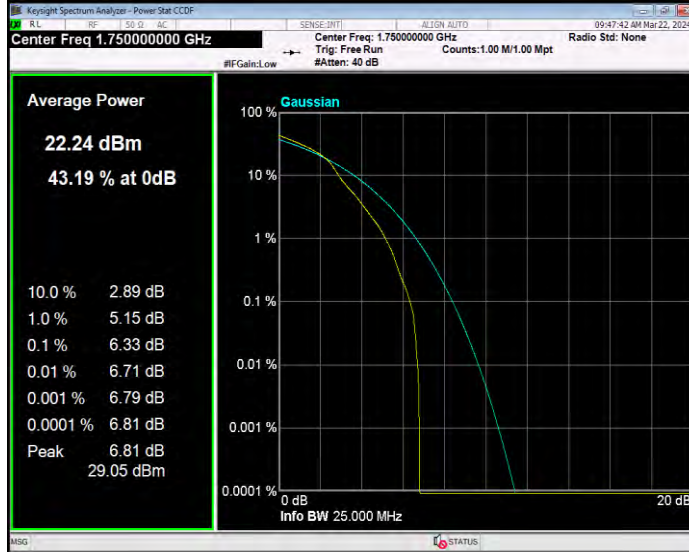

**Band4 16QAM BW=15MHz Channel=20025 RB Size=1 Position=#0**

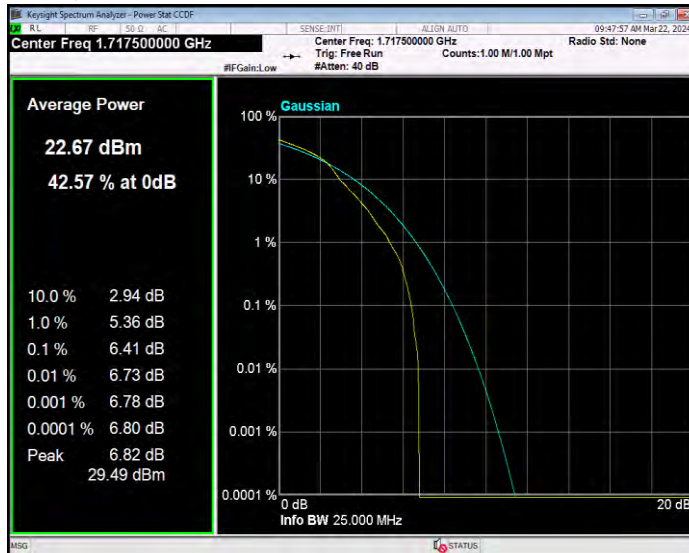

**Band4 16QAM BW=15MHz Channel=20175 RB Size=1 Position=#0**

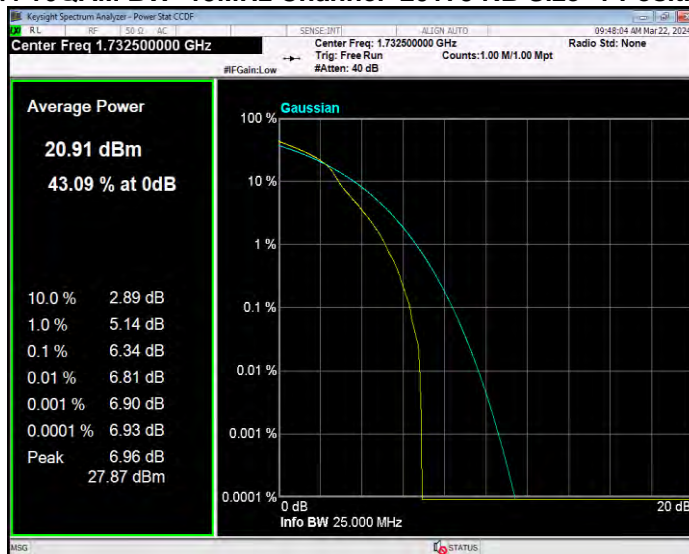

**Band4 16QAM BW=15MHz Channel=20325 RB Size=1 Position=#0**



**Band4 16QAM BW=20MHz Channel=20050 RB Size=1 Position=#0**



**Band4 16QAM BW=20MHz Channel=20175 RB Size=1 Position=#0**

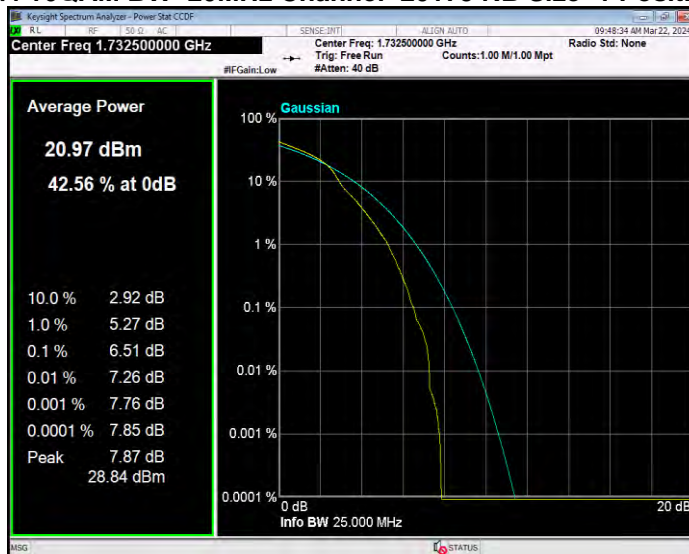



**Band4 16QAM BW=20MHz Channel=20300 RB Size=1 Position=#0**



**Band4 16QAM BW=3MHz Channel=19965 RB Size=1 Position=#0**

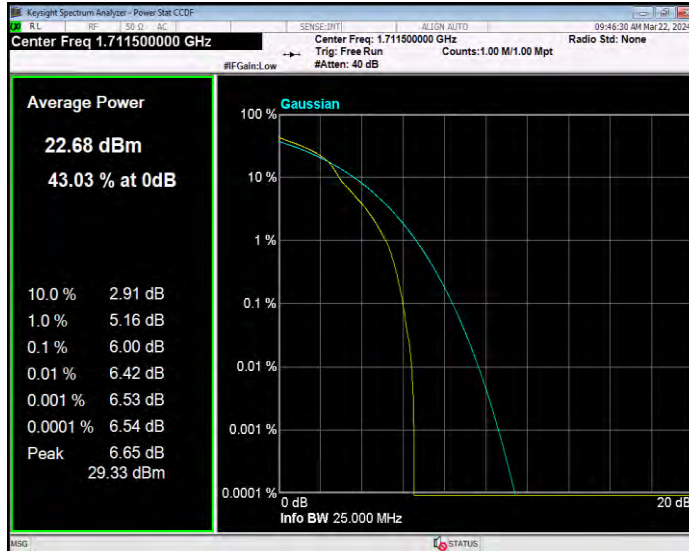

**Band4 16QAM BW=3MHz Channel=20175 RB Size=1 Position=#0**

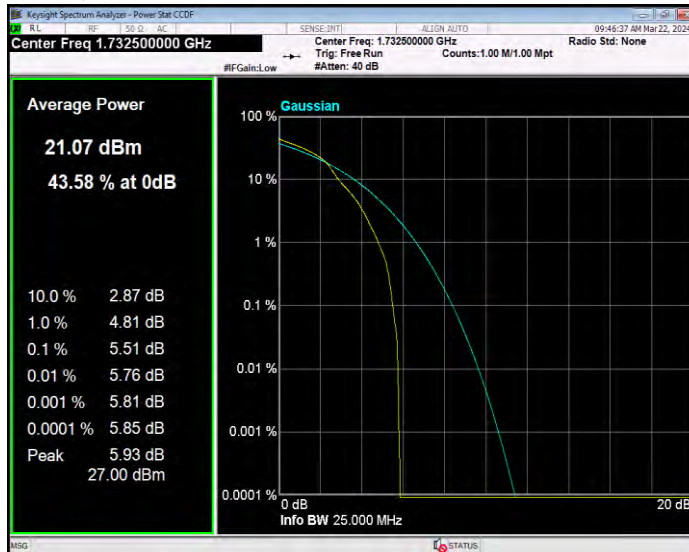

**Band4 16QAM BW=3MHz Channel=20385 RB Size=1 Position=#0**



**Band4 16QAM BW=5MHz Channel=19975 RB Size=1 Position=#0**

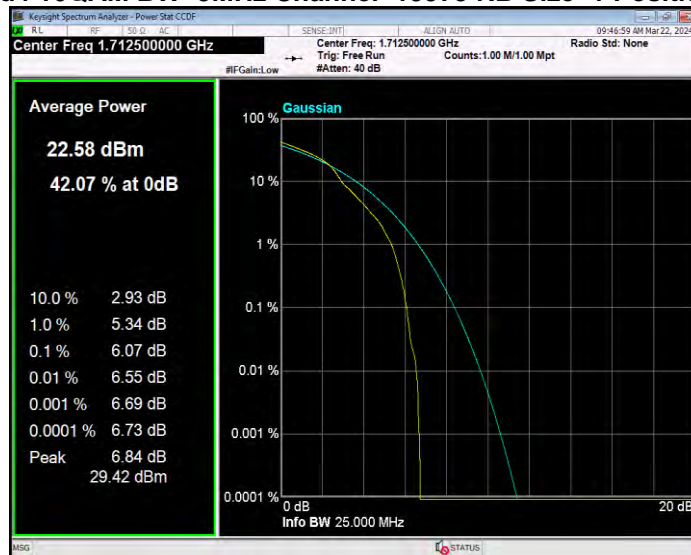

**Band4 16QAM BW=5MHz Channel=20175 RB Size=1 Position=#0**

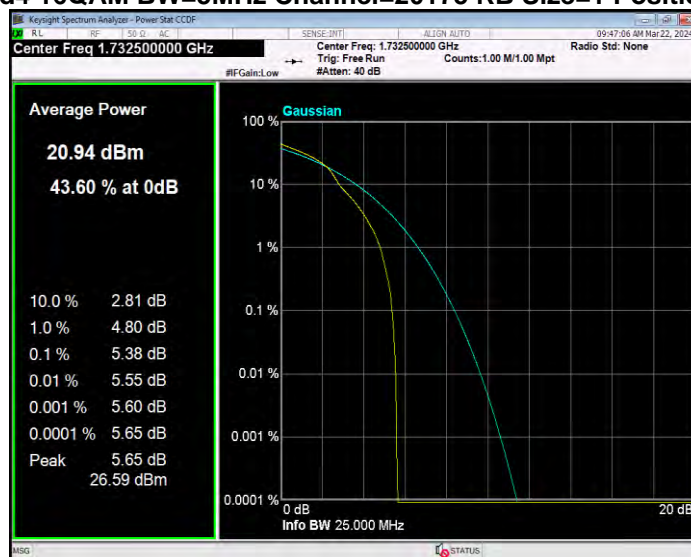

**Band4 16QAM BW=5MHz Channel=20375 RB Size=1 Position=#0**

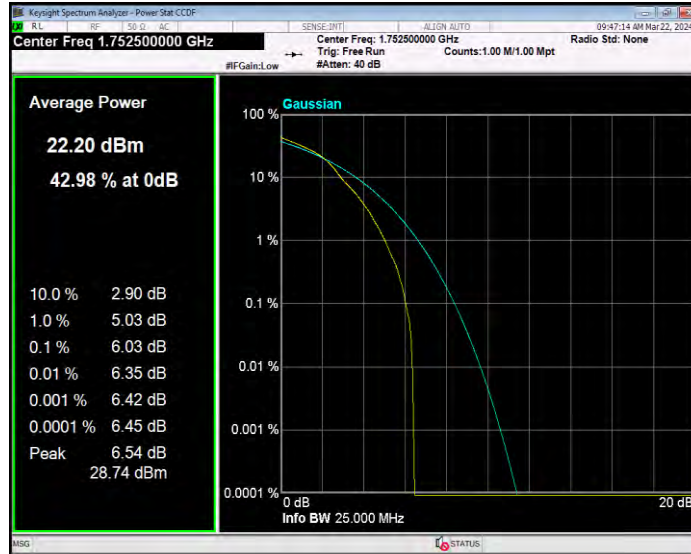

**Band4 QPSK BW=1.4MHz Channel=19957 RB Size=1 Position=#0**

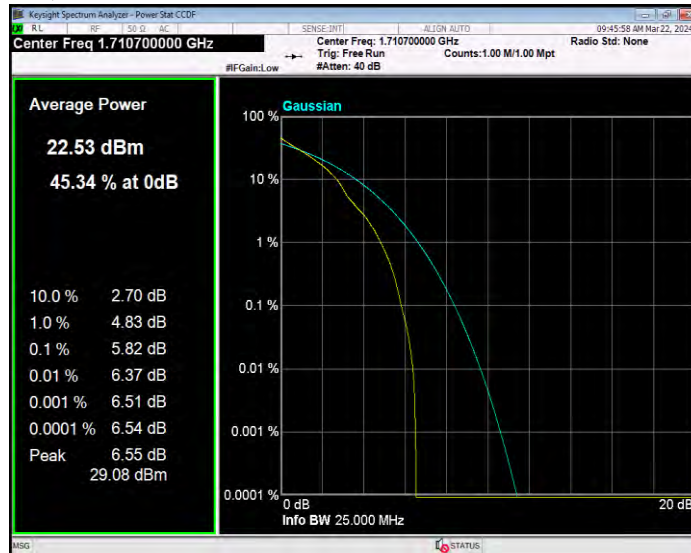

**Band4 QPSK BW=1.4MHz Channel=20175 RB Size=1 Position=#0**

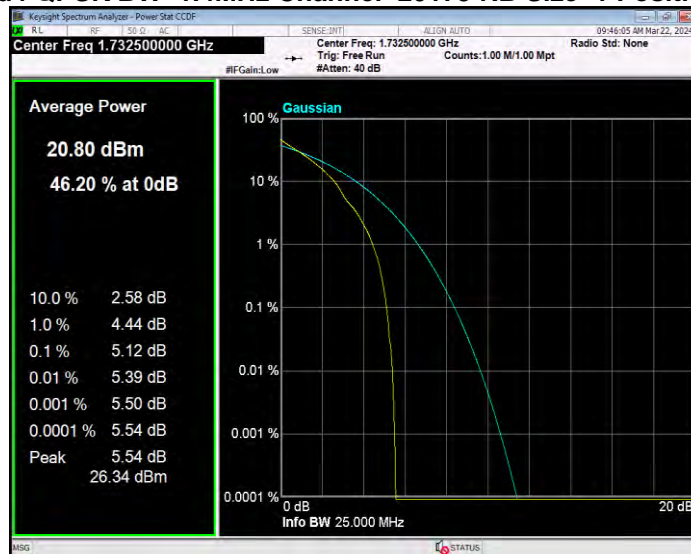

**Band4 QPSK BW=1.4MHz Channel=20393 RB Size=1 Position=#0**

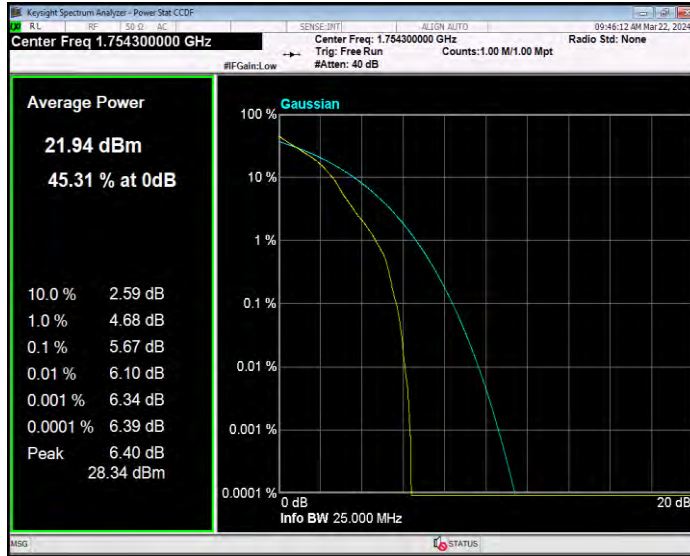

**Band4 QPSK BW=10MHz Channel=20000 RB Size=1 Position=#0**



**Band4 QPSK BW=10MHz Channel=20175 RB Size=1 Position=#0**

