

承 認 書

SPECIFICATION FOR APPROVAL

客 戶:
CUSTOMER: 深圳钟艺科技 Shenzhen Zhongyi Technology

客 戶 料 號:
CUST P/N:

料 號: Y Z X
P/N:

產 品 型 號:
DESC: **RC-G25-7.7UH-3700GS-65MM**

日 期:
DATE: **2024/1/11**

supplier: 东莞市捷瑞思科技有限公司
Dongguan Jireisi technology Co., LTD

No.96 Longhu Road, Dalingshan Town, Dongguan (Jinxiongda Science Park L building 3 / F)

擬制 PREPARED BY	審核 CHECKED BY	批准 APPROVED BY	客戶承認 CUSTOMER APPROVE
王莉芝	邓祥桂	李建波	陆如圣

一、Plane structure diagram: unit:MM

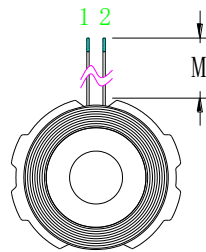
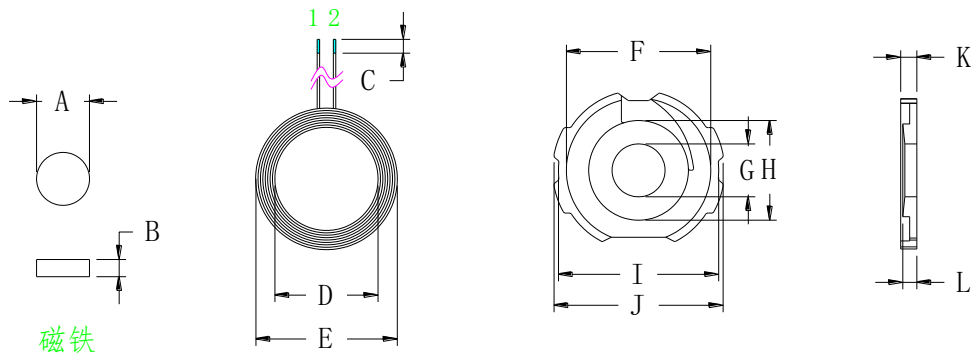

A	7.65 ± 0.05
B	4.0 ± 0.05
C	2 ± 1
D	14 ± 0.2
E	20.7 ± 0.3
F	21 ± 0.2
G	7.7 ± 0.05
H	13.5 ± 0.2
I	23.5 ± 0.3
J	25 ± 0.2
K	2.5 ± 0.1
L	2.25 ± 0.1
M	65 ± 2

二、Product Parameter:

foot position	Wire diameter	number of turns	
1 - 2	0.08*24P	14	