

承 認 書

SPECIFICATION FOR APPROVAL

客 戶:
CUSTOMER:

客 戶 料 號:
CUST P/N:

03020800020

言 之 行 料 號:
Y Z X P/N:

YZX44

產 品 型 號:
DESC:

Φ43.5MMX5.0MM

日 期:
DATE:

2023/2/28

版 本:
Version:

A.0

擬制 PREPARED BY	審核 CHECKED BY	批准 APPROVED BY	客戶承認 CUSTOMER APPROVE

东莞市言之行电子科技有限公司

Dongguan Yan line electronic technology Co., LTD

工廠地址：东莞市塘厦镇石马新围8号

address: No.8 Shima Xinwei, Tangxia Town, Dongguan City

SPECIFICATION

產品型號: DESC	Φ 43.5MMX5.0MM	版本 Rev: A.0	客戶 CUST: 客戶料号 CUST P/N:	
---------------	-----------------------	----------------	----------------------------	--

一、尺寸 DIMENSION:(mm)

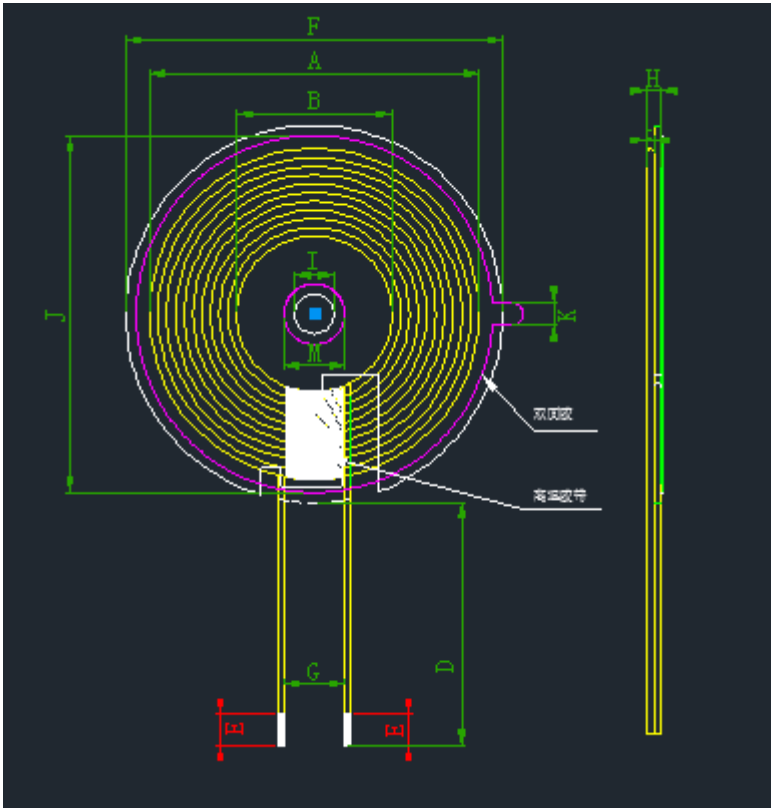

A	39.0±1.5
B	20.5±0.5
C	1.25 Max
D	55±3
E	2-5
F	43±2
G	10.0 ref
H	1.6Max
I	5.3 ref
M	8.0 ref
J	42±1
K	3.0±1

二、原理图 SCHEMATIC DIAGRAM:



三、绕线参数 Winding Specification:

序号 NO.	端子 TERMINAL		线径 WIRE	圈数 Turns	绕线方向 Winding Direction
1	S	F	24*0.08*2p	10Ts	CCW

四、电气特性 ELECTRICAL CHARACTERISTICS:

温度 TEMPERATURE:25±10°C, 湿度 RELATIVE HUMIDITY:65±20%

序号 NO.	项目 ITEM	端子 TERMINAL	标准 SPECIFICATION	测试条件 TEST FREQUENCY	测试仪器 TEST EQUIPMENTS
1	IND.	S-F	3.8uH ±20% Individual coil	100KHz/1.0V	LCZ METER 1062B
2	IND.	S-F	6.4uH ±10% add magnetic sheet	100KHz/1.0V	LCZ METER 1062B
3	DCR	S-F	≤120mΩ		LCZ METER 502B

擬制/日期 PREPARED BY/DATE	審核/日期 CHECKED BY/DATE
------------------------	-----------------------