

SHENZHEN YINLONG TENFEI ELECTRONICS CO.LED

Client SHENZ YUEXIN ELECTRONICS

NO EL.X.XQ00000009

Model NO Wireless charging coil 50 -6.5UH

material number Client p/NO 003
Date 2022-12-8

OUR ENGINEER/For	
REVISE CONTENT/	THE DATE/

Prepared _____ Checked _____ Approved _____

CUSTOMER CONFIRMATION		
ENGINEER	QC	THE DATE

SHENZHEN YINLONG TENFEI ELECTRONICS CO.LED

一、 WINDING

NO	1	WAG	TURNS	DIRECTION WINDING	REMARK
1	N1	2UEW-B-0.08*105P	12TS	CCW	
2					

二 . FEATURES:

1. (Test conditions) : 25°C,65%RH@1KHz/0.3V

1.1 (Inductance)

1.11 L0A=6.5uH±20%

1.12 L0A=6.5uH±10%

1.2 Q =70MIN

1.3 (DCR) : 55mΩ MAX

1.4 (Operating Temperature) : -25°C~85°C

2. (Test instrument) : **L:**WEIRI 102;**DCR:**TH2811D;**SIZE:**Callipers

3.MATERIAL LIST

NO	PROJECT	MATERIAL
1	WIRE	φ 0.08*105p 2UEW-1.2mm
2	FERRITE	50*0.56*1.0MM DOUBLE-SLOT FERRITE HARD MAGNET
3	GLUE	WHITE
4	SOLDER	XCD-907B
5	Adhesive	WHITE
6	High temperature adhesive	6MM
7		
8		

SHENZHEN YINLONG TENFEI ELECTRONICS CO.LED

三 . CIRCUIT DIAGRAM

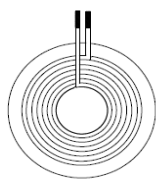

N1



UNIT : MM

四 . OUTSIDE DIAGRA

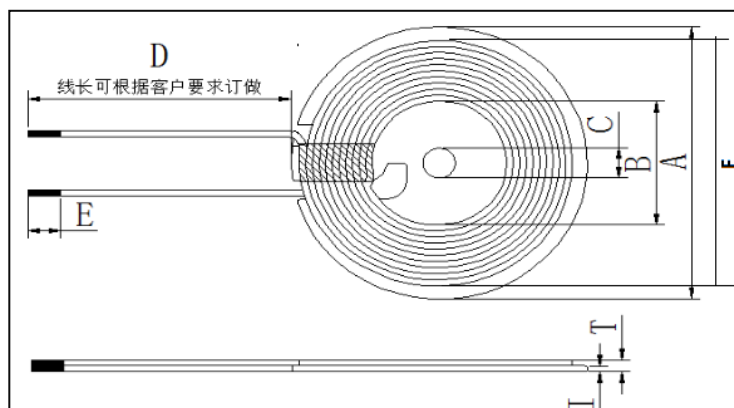

REMARK : THE COIL FOOT LENGTH CAN BU CUSTOMIZEDFOR CUSTOMER,THE COVER 6MM HIGH TEMPERATURE TAPE AT THE COIL OUTLET

STA NDA RD	A	B	C	D	E	F	I	T
STD	43.5	20.5	5.0± 0.5	FOR CUSTOM ER	2-3	41±1.2	0.8±0.1	2.0Max

UNIT : MM

SHENZHEN YINLONG TENFEI ELECTRONICS CO.LED

五 . PACKAGE

5.1 Packing pictures:

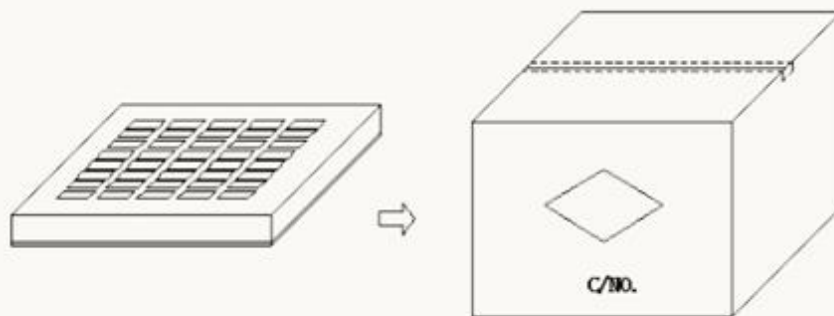

5.2 Packing Quantity:

Item	Quantity	Material
Box	350 Pcs	345*330*50 mm
Big Carton	1440 Pcs	360*340*280 mm

THE PACKING CAN BU CUSTOMIZED FOR CUSTOMER ,THANKS A LOT.

SHENZHEN YINLONG TENFEI ELECTRONICS CO.LED

六、Storage and Use condition

6.1 Storage condition

6.1.1 Recommended keeping conditions: $-25^{\circ}\text{C} \sim 85^{\circ}\text{C}$, 70%RH (Max.)

6.1.2 Storage life : Within the limits of six months from being produced.

6.2 Use condition

Use condition limit: $T=-25^{\circ}\text{C} \sim 85^{\circ}\text{C}$, $\text{RH} \leq 90\%$.