

wifi module specification

Revisionrecord

date	edition	DescriptionOn	Reviser
2022-11-30	V1.0	Initialversion	james

catalog

HB55 module specification	1
1. Productoverview.....	3
1.1. characteristic	3
1.2. application.....	3
2. Productspecifications.....	4
3. Electrical specifications	4
3.1. DC characteristics.....	4
3.2. powerwaste.....	4
3.3. RF characteristics.....	5
3.3.1. Transmitterperformance.....	5
3.3.2. Receiver performance.....	5
4. Pindefinition.....	6
5. ModuleSize.....	7
5.1. Packagesize.....	7
5.2. Layoutsize.....	7
6. Reference design of externalantenna.....	8
7. Reference design of USB interface	9
8. reflowprofile.....	10

1. Productoverview

The HB55_V0.1 is a 2.4GHz 802.11n product. with audio peripherals and image sensor interface. with a full 802.11b/g/n audio/video. with support for both AP and STA applications.

1. 1. characteristic

- 📁 802.11 b/g/n 1x1 compliant
- 📁 20/40 MHz bandwidth and STBC
- 📁 Working mode STA, AP, Direct
- 📁 AP and STA role simultaneously
- 📁 32-bit MCU up to 180 MHz
- 📁 50 MHz SDIO interface
- 📁 Dual I2C interface
- 📁 Dual high speed UART with flow control capability
- 📁 One channel audio ADC
- 📁 CMOS sensor 8-bit DVP
- 📁 SupportAES/RSA/SHA

1. 2. application

- 📁 MiniDV
- 📁 WiFiendoscope
- 📁 Toyplane

2. Productspecifications

Model	HB55_V0.1
ProductName	2.4GHz 802.11n Module
MajorChipset	BK7252
Standard	802.11b/g/n
DataTransferRate	Upto54Mbps
ModulationMethod	DSSS/OFDM/HT40/HT20/STBC
FrequencyBand	2.4GHz ISM Band
Spread Spectrum	IEEE 802.11b: DSSS (DirectSequenceSpreadSpectrum) IEEE 802.11g/n:OFDM (Orthogonal Frequency Division Multiplexing)
OperationMode	InfrastructureSSID
OperatingChannel	1~11
Security	AES, RSA, SHA
OperatingTemperature	-20 ~ 85. C Ambient Temperature
Dimension	

3. Electricalspecifications

3.1. DCcharacteristics

Symbol	Parameter	Minimum	Typical	Maximum	Units
VBAT	VBAT Supply Voltage	3.55		4.2	V
DC-5V	DC_5V-Input	4.0		5.0	V

3.2. powerwaste

Thefollowingpowerconsumptiondataisbasedon3.3V power supply, 25 C ambienttemperature, completedattheRFinterface.Alltransmitteddataaremeasuredbased on100% duty cycle, and the CPU runs at 180mhz.

RFpowerconsumption			
Workingmode	describe		Peakvalue (MA)
Active(VBAT Mode)	TX	17dBm, 802.11b, 11Mbps	230
		14dBm, 802.11g, 54Mbps	200
	RX	-10dBm input, 802.11g 54Mbps	104
		-10dBm input, 802.11n HT40 MCS7	124

3.3. RFcharacteristics

3.3.1. Transmitterperformance

parameter	condition	Typicalvalue (DBM)
output power	54 Mbps OFDM	15
	11 Mbps DSSS	19

3.3.2. Receiverperformance

parameter	condition	Typicalvalue (DBM)
Receiving sensitivity	HT40 MCS7	-69
	HT20 MCS7	-71
	54 Mbps OFDM	-75
	6 Mbps OFDM	-92
	11 Mbps DSSS	-90
	2 Mbps DSSS	-94

4. Pindefinition

Serialnum ber	Pin name	Pin type	Functiondescription
1	GND	GROUND	Grounding
2	VBAT	VBAT	Powerinput
3	DC_5V-Input	DC-5V POWER	DC power input
4	GND	GROUND	Grounding
5	DC_5V-Input	DC-5V POWER	DC 5V input USB
6	RX	UART RX	UART Receiver
7	TX	UART TX	UART Transmitter

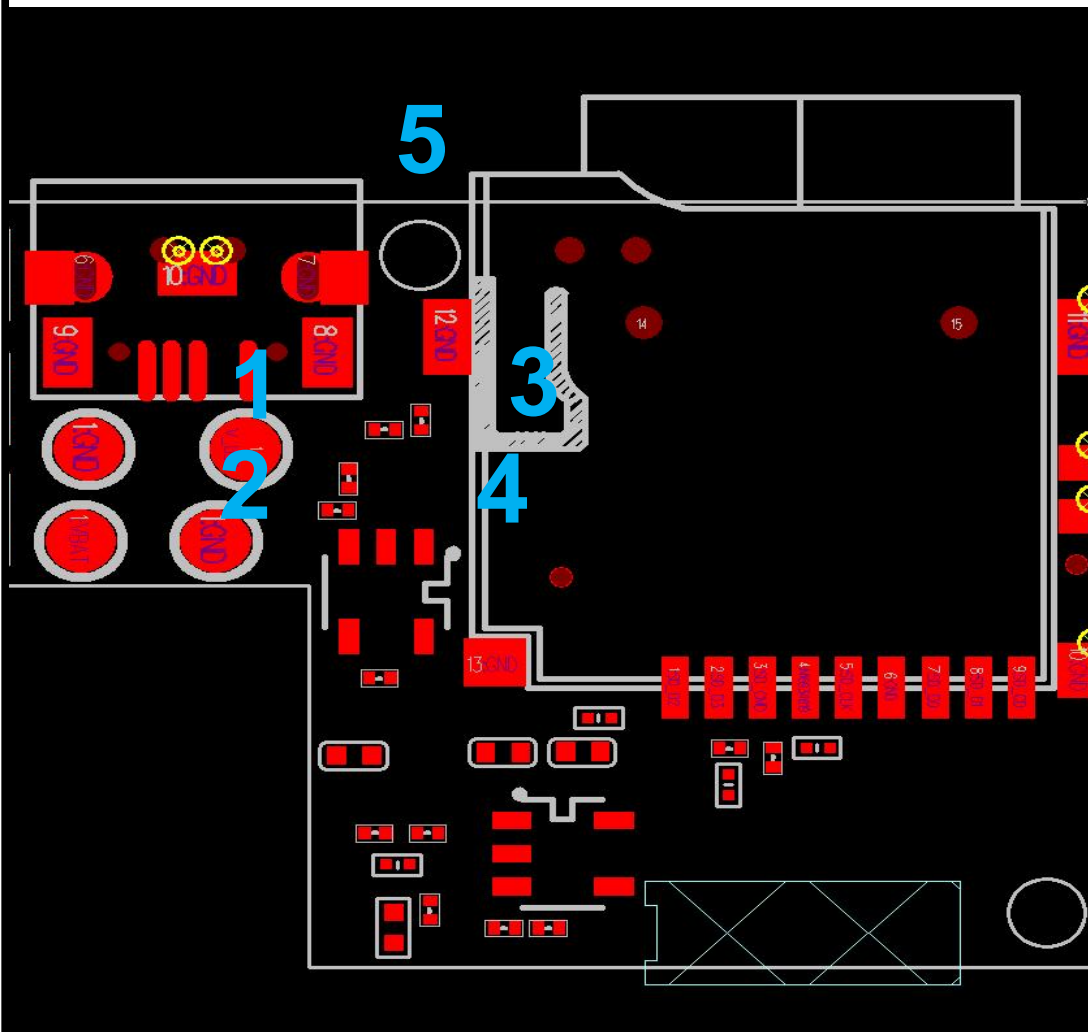

6
7

5. ModuleSize

5. 1. Packagesize

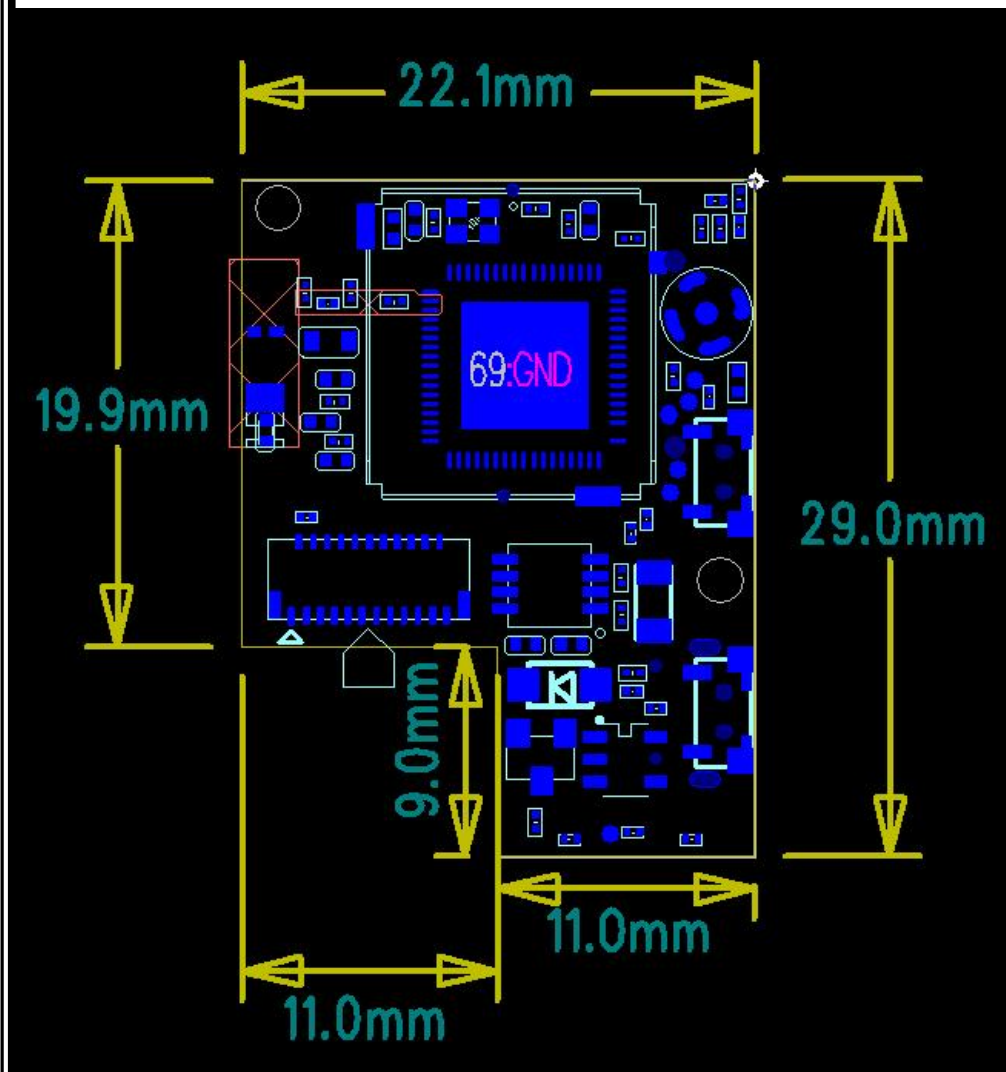

6. Referencedesignofexternalantenna

The RF portofBK7252 is ant

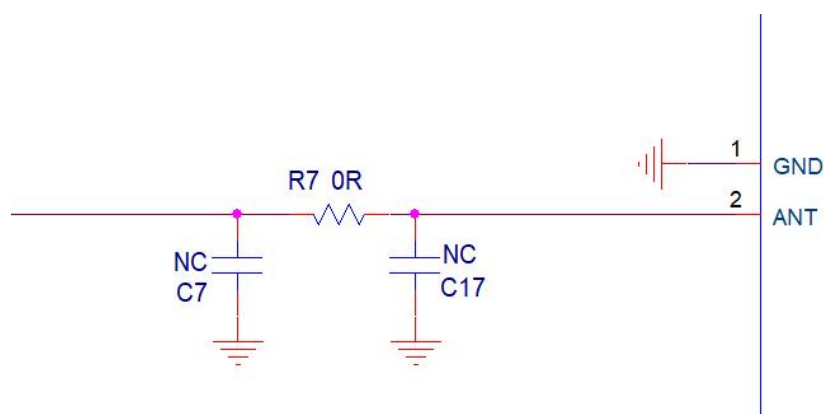

DuringPCBlayout, attentionshouldbepaid to:

- (1) If the ant is far away from the antenna,
itisrecommendedtoreservetwo π circuits on PCB to match ant and antenna
respectively;
- (2) WhenPCBlayout, ifPCBspaceconstraintsleadtopowerfilter / crystal oscillator
/ resetcircuitlayoutconflict, itisrecommendedtogivepriorityto
antennalayout;Whenthelayoutofantennaandmoduleiscompact, firstly, the matching
link can be saved;Secondly, the loss of RF signal can be reduced, so as to
improvetheperformanceofairinterface;
- (3) TheRFsignallineshouldbeasshortaspossible. Thecontrolimpedanceis 50R. Both
sides of the wiring are covered with ground and more ground holes are drilled.
The bottom and the bottom of the chip ensure the complete ground plane,
sothattheRFreferencegroundandthechipmainground are well connected.

8. reflowprofile

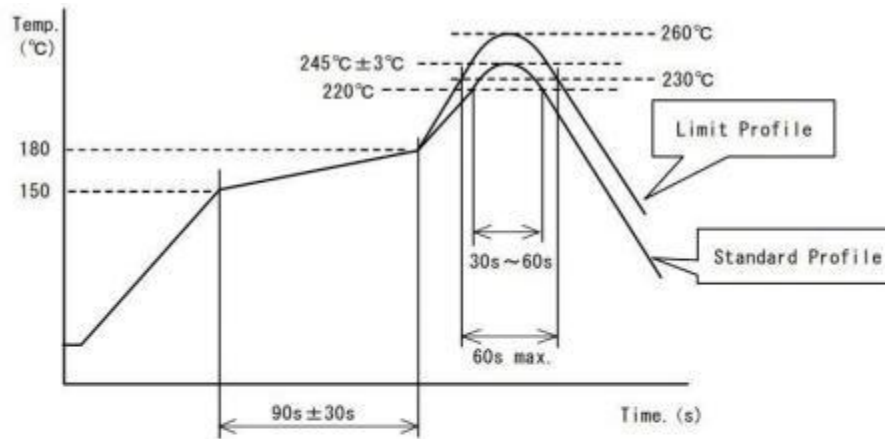

	Standard Profile	Limit Profile
Pre-heating	150°C~180°C, 90s±30s	
Heating	above 220°C, 30s~60s	above 230°C, 60s max.
Peak temperature	245°C±3°C	260°C, 10s
Cycle of reflow	2 times	2 times

FCC WARNING

FCC Caution: Any changes or modifications not expressly approved by the party responsible for compliance could void the user's authority to operate this equipment.

This device complies with Part 15 of the FCC Rules.

Operation is subject to the following two conditions: (1) This device may not cause harmful interference, and (2) this device must accept any interference received, including interference that may cause undesired operation.

This device and its antenna(s) must not be co-located or operating in conjunction with any other antenna or transmitter.

15.105 Information to the user.

(b) For a Class B digital device or peripheral, the instructions furnished the user shall include the following or similar statement, placed in a prominent location in the text of the manual:

Note: This equipment has been tested and found to comply with the limits for a Class B digital device, pursuant to part 15 of the FCC Rules. These limits are designed to provide reasonable protection against harmful interference in a residential installation. This equipment generates, uses and can radiate radio frequency energy and, if not installed and used in accordance with the instructions, may cause harmful interference to radio communications. However, there is no guarantee that interference will not occur in a particular installation. If this equipment does cause harmful interference to radio or television reception, which can be determined by turning the equipment off and on, the user is encouraged to try to correct the interference by one or more of the following measures:

- Reorient or relocate the receiving antenna.
- Increase the separation between the equipment and receiver.
- Connect the equipment into an outlet on a circuit different from that to which the receiver is connected.
- Consult the dealer or an experienced radio/TV technician for help.

This equipment complies with FCC radiation exposure limits set forth for an uncontrolled environment. This equipment should be installed and operated with minimum distance 20

cm between the radiator and your body.

Radiation Exposure Statement:

This equipment complies with FCC radiation exposure limits set forth for an uncontrolled environment.

This transmitter must not be co-located or operating in conjunction with any other

antenna or transmitter.

The availability of some specific channels and/or operational frequency bands are country dependent and are firmware programmed at the factory to match the intended destination.

The firmware setting is not accessible by the end user.

The final end product must be labelled in a visible area with the following:

“Contains Transmitter Module “2A9H6-PETA1”

Requirement per KDB996369 D03

2.2 List of applicable FCC rules

List the FCC rules that are applicable to the modular transmitter. These are the rules that specifically establish the bands of operation, the power, spurious emissions, and operating fundamental frequencies. DO NOT list compliance to unintentional-radiator rules (Part 15 Subpart B) since that is not a condition of a module grant that is extended to a host manufacturer. See also Section 2.10 below concerning the need to notify host manufacturers that further testing is required.³

Explanation: This module meets the requirements of FCC part 15C (15.247). It specifically identified AC Power Line Conducted Emission, Radiated Spurious emissions, Band edge and RF Conducted Spurious Emissions, Conducted Peak Output Power, Bandwidth, Power Spectral Density, Antenna Requirement.

2.3 Summarize the specific operational use conditions

Describe use conditions that are applicable to the modular transmitter, including for example any limits on antennas, etc. For example, if point-to-point antennas are used that require reduction in power or compensation for cable loss, then this information must be in the instructions. If the use condition limitations extend to professional users, then instructions must state that this information also extends to the host manufacturer's instruction manual. In addition, certain information may also be needed, such as peak gain per frequency band and minimum gain, specifically for master devices in 5 GHz DFS bands.

Explanation: The product antenna uses an irreplaceable antenna with a gain of 1dBi

2.4 Single Modular

If a modular transmitter is approved as a "Single Modular," then the module manufacturer is responsible for approving the host environment that the Single Modular is used with. The manufacturer of a Single Modular must describe, both in the filing and in the installation instructions, the alternative means that the Single Modular manufacturer uses to verify that the host meets the necessary requirements to satisfy the module limiting conditions.

A Single Modular manufacturer has the flexibility to define its alternative method to address the conditions that limit the initial approval, such as: shielding, minimum signaling amplitude, buffered modulation/data inputs, or power supply regulation. The alternative method could include that the limited

module manufacturer reviews detailed test data or host designs prior to giving the host manufacturer approval.

This Single Modular procedure is also applicable for RF exposure evaluation when it is necessary to demonstrate compliance in a specific host. The module manufacturer must state how control of the product into which the modular transmitter will be installed will be maintained such that full compliance of the product is always ensured. For additional hosts other than the specific host originally granted with a limited

module, a Class II permissive change is required on the module grant to register the additional host as a specific host also approved with the module.

Explanation: The module is a single module.

2.5 Trace antenna designs

For a modular transmitter with trace antenna designs, see the guidance in Question 11 of KDB Publication 996369 D02 FAQ – Modules for Micro-Strip Antennas and traces. The integration information shall include for the TCB review the integration instructions for the following aspects: layout of trace design, parts list (BOM), antenna, connectors, and isolation requirements.

- a) Information that includes permitted variances (e.g., trace boundary limits, thickness, length, width, shape(s), dielectric constant, and impedance as applicable for each type of antenna);
- b) Each design shall be considered a different type (e.g., antenna length in multiple(s) of frequency, the wavelength, and antenna shape (traces in phase) can affect antenna gain and must be considered);
- c) The parameters shall be provided in a manner permitting host manufacturers to design the printed circuit (PC) board layout;
- d) Appropriate parts by manufacturer and specifications;
- e) Test procedures for design verification; and
- f) Production test procedures for ensuring compliance

The module grantee shall provide a notice that any deviation(s) from the defined parameters of the antenna trace, as described by the instructions, require that the host product manufacturer must notify the module grantee that they wish to change the antenna trace design. In this case, a Class II permissive change application is required to be filed by the grantee, or the host manufacturer can take responsibility through the change in FCC ID (new application) procedure followed by a Class II permissive change application

2.6 RF exposure considerations

It is essential for module grantees to clearly and explicitly state the RF exposure conditions that permit a host product manufacturer to use the module. Two types of instructions are required for RF exposure information: (1) to the host product manufacturer, to define the application conditions (mobile, portable – xx cm from a person's body); and (2) additional text needed for the host product manufacturer to provide to end users in their end-product manuals. If RF exposure statements and use conditions are not provided, then the host product manufacturer is required to take responsibility of the module through a change in FCC ID (new application).

Explanation: The module complies with FCC radiofrequency radiation exposure limits for uncontrolled environments. The device is installed and operated with a distance of more than 20 cm between the radiator and your body." This module follows FCC statement design, FCC ID :2A9H6-PETA1

2.7 Antennas

A list of antennas included in the application for certification must be provided in the instructions. For modular transmitters approved as limited modules, all applicable professional installer instructions must be included as part of the information to the host product manufacturer. The antenna list shall also identify the antenna types (monopole, PIFA, dipole, etc. (note that for example an "omni-directional antenna" is not considered to be a specific "antenna type").

For situations where the host product manufacturer is responsible for an external connector, for example with an RF pin and antenna trace design, the integration instructions shall inform the installer that unique antenna connector must be used on the Part 15 authorized transmitters used in the host product.

The module manufacturers shall provide a list of acceptable unique connectors.

Explanation: The product antenna uses an irreplaceable antenna with a gain of 2dBi

2.8 Label and compliance information

Grantees are responsible for the continued compliance of their modules to the FCC rules. This

includes advising host product manufacturers that they need to provide a physical or e-label stating "Contains FCC ID" with their finished product. See Guidelines for Labeling and User Information for RF Devices – KDB Publication 784748.

Explanation: The host system using this module, should have label in a visible area indicated the following texts: "Contains FCC ID: 2A9H6-PETA1

2.9 Information on test modes and additional testing requirements

Additional guidance for testing host products is given in KDB Publication 996369 D04 Module Integration Guide. Test modes should take into consideration different operational conditions for a stand-alone modular transmitter in a host, as well as for multiple simultaneously transmitting modules or other transmitters in a host product.

The grantee should provide information on how to configure test modes for host product evaluation for different operational conditions for a stand-alone modular transmitter in a host, versus with multiple, simultaneously transmitting modules or other transmitters in a host.

Grantees can increase the utility of their modular transmitters by providing special means, modes, or instructions that simulates or characterizes a connection by enabling a transmitter. This can greatly simplify a host manufacturer's determination that a module as installed in a host complies with FCC requirements.

Explanation: Ningde linyang Electronic Technology Co., Ltd. can increase the utility of our modular transmitters by providing instructions that simulates or characterizes a connection by enabling a transmitter.

2.10 Additional testing, Part 15 Subpart B disclaimer

The grantee should include a statement that the modular transmitter is only FCC authorized for the specific rule parts (i.e., FCC transmitter rules) listed on the grant, and that the host product manufacturer is responsible for compliance to any other FCC rules that apply to the host not covered by the modular transmitter grant of certification. If the grantee markets their product

as being Part 15

Subpart B compliant (when it also contains unintentional-radiator digital circuitry), then the grantee shall provide a notice stating that the final host product still requires Part 15 Subpart B compliance testing with the modular transmitter installed.

Explanation: The module without unintentional-radiator digital circuitry, so the module does not require an evaluation by FCC Part 15 Subpart B. The host should be evaluated by the FCC Subpart B.