

iENYRID

Enjoy Your Ride

Please noted that your Mini functions might be not consistit with this Manual due to technical upgrading and firmware updates. Please install the App for latest funtion & safety instructions

QUICK START MANUAL

iENYRID

Enjoy Your Ride

Please noted that your Mini functions might be not consistit with this Manual due to technical upgrading and firmware updates. Please install the App for latest funtion & safety instructions

QUICK START MANUAL

iENYRID

Enjoy Your Ride

Please noted that your Mini functions might be not consistit with this Manual due to technical upgrading and firmware updates. Please install the App for latest funtion & safety instructions

QUICK START MANUAL

14 Harzardous Substances Declaration

Component	Pb	Cd	Hg	Cr (VI)	PBB	PBDE
Plastic part	○	○	○	○	○	○
Dashboard	×	×	○	○	○	○
LED	×	○	○	○	○	○
Steering bar	×	○	○	○	○	○
Mainframe	○	○	○	○	○	○
Battery pack	○	○	○	○	○	○
Motor	○	○	○	○	○	○
Charger	×	○	○	○	○	○

○ The contents of the toxic and hazardous substances contained are beblow SJ/T 11363-2006 standard
 × Indicates the hazardous substances contained exceed the SJ/T 11363-2006 standard

14

Content

1 Packing List	01
2 Mini Diagram	02
3 Icons on the Dashboard	03
4 Assemble Your Mini	04
5 First Ride	05
6 Charging	06
7 Learn to Ride	07
8 Warning	08
9 Forbidden Behaviour	09
10 Riding Safety	10
11 Lifting and Assistance Mode	11
12 Daily Maintenance	12
13 Specifications	13
14 Harzardous Substances Declaration	14

14 Harzardous Substances Declaration

Component	Pb	Cd	Hg	Cr (VI)	PBB	PBDE
Plastic part	○	○	○	○	○	○
Dashboard	×	×	○	○	○	○
LED	×	○	○	○	○	○
Steering bar	×	○	○	○	○	○
Mainframe	○	○	○	○	○	○
Battery pack	○	○	○	○	○	○
Motor	○	○	○	○	○	○
Charger	×	○	○	○	○	○

○ The contents of the toxic and hazardous substances contained are beblow SJ/T 11363-2006 standard
 × Indicates the hazardous substances contained exceed the SJ/T 11363-2006 standard

14

Content

1 Packing List	01
2 Mini Diagram	02
3 Icons on the Dashboard	03
4 Assemble Your Mini	04
5 First Ride	05
6 Charging	06
7 Learn to Ride	07
8 Warning	08
9 Forbidden Behaviour	09
10 Riding Safety	10
11 Lifting and Assistance Mode	11
12 Daily Maintenance	12
13 Specifications	13
14 Harzardous Substances Declaration	14

14 Harzardous Substances Declaration

Component	Pb	Cd	Hg	Cr (VI)	PBB	PBDE
Plastic part	○	○	○	○	○	○
Dashboard	×	×	○	○	○	○
LED	×	○	○	○	○	○
Steering bar	×	○	○	○	○	○
Mainframe	○	○	○	○	○	○
Battery pack	○	○	○	○	○	○
Motor	○	○	○	○	○	○
Charger	×	○	○	○	○	○

○ The contents of the toxic and hazardous substances contained are beblow SJ/T 11363-2006 standard
 × Indicates the hazardous substances contained exceed the SJ/T 11363-2006 standard

14

Content

1 Packing List	01
2 Mini Diagram	02
3 Icons on the Dashboard	03
4 Assemble Your Mini	04
5 First Ride	05
6 Charging	06
7 Learn to Ride	07
8 Warning	08
9 Forbidden Behaviour	09
10 Riding Safety	10
11 Lifting and Assistance Mode	11
12 Daily Maintenance	12
13 Specifications	13
14 Harzardous Substances Declaration	14

Thanks for choosing mini!

Thanks for choosing MINIROBOT (hereinafter referred to as Mini)
Your Mini is a new form of electrical balancing vehicle with smartphone App features.

Enjoy your free riding now!

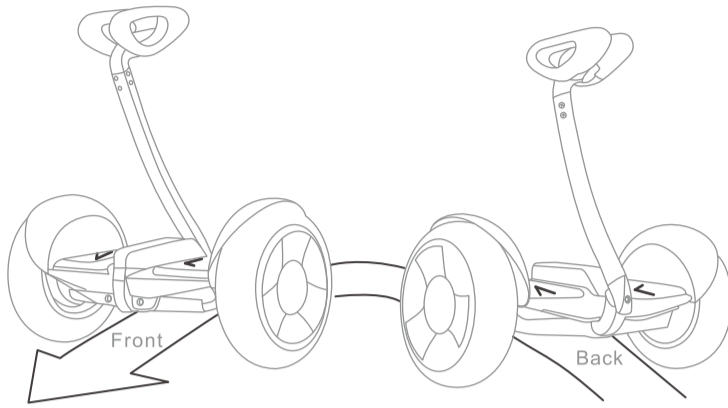

Hint: Please step on/off from the Back!
Or you will risk crash/fall due to wrong steering direction!

13 Specifications

Index	Items	Parameters
Dimension	L x W (mm)	262x546
	Mainframe H[1] (mm)	611 ~ 866
Weight	Payload	20 ~ 100 kg (44~220 lb)
	Net	Approx. 13.0 kg
Rider Requirement	Applicable Age	16 ~ 50
	Applicable Height	120 ~ 200 cm (3.9 ~ 6.6 ft)
Machine Parameter	Max.Speed	Approx. 16 km/h (10 mph)
	Max. Climbing Angle	Approx. 15°
	Beginner Mode	Can be disabled or reset by App after 1km (0.6mi) riding, accumulative riding can be reset by App
	Applicable Terrain	Harden pavement, flat dirt pavement, down ramp < 15°, staircase < 1cm, groove width < 3cm
	Operation Temp.	-10°C ~ +40°C (-14°F ~ 104°F)
	Storage Temp.	-20°C ~ +45°C (-4°F ~ 113°F)
	IP grade	IP54
Battery Pack	Nominal Voltage (V)	54.8 ~ 36V / 54.8V
	Max.Charging Voltage (V)	63 ~ 42V / 63V
	Nominal Capacity (Wh)	144 / 236
	Smart BMS	Overvoltage/Undervoltage/Short Circuit/Overheating Protection, Auto-Sleep /Wake-up, detailed information of battery can be checked with App
Motor	Nominal Power(W)	350x2
	Max.Power(W)	700x2
	Nominal Power(W)	120
Charger	Nominal Input Voltage(V)	100 ~ 240V ~ 50~60Hz
	Nominal Output Voltage (V)	Approx. 42 / 63
	Nominal Output Current (A)	Approx. 1.0
	Charging Time (H)	Approx. 3.2~5

[1] Mainframe height: refer to distance from ground to the highest end of mainframe.
[2] Typical mileage refers to: test under riding in full power, 70kg(154lb) load, 25°C (77°F) environmental temperature, 15km/h (9.3 mph) average speed on-pavement.

13

Thanks for choosing mini!

Thanks for choosing MINIROBOT (hereinafter referred to as Mini)
Your Mini is a new form of electrical balancing vehicle with smartphone App features.

Enjoy your free riding now!

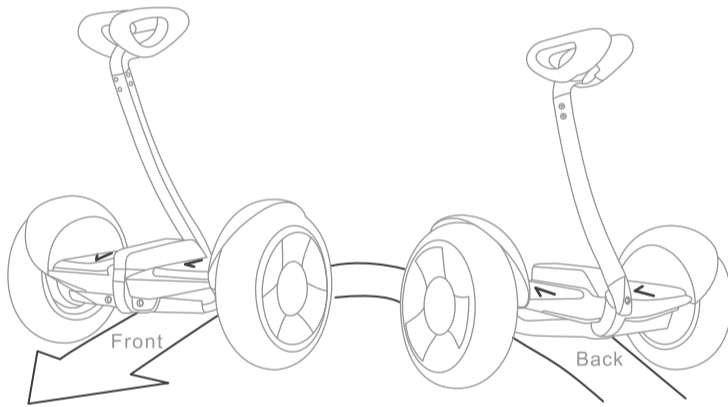

Hint: Please step on/off from the Back!
Or you will risk crash/fall due to wrong steering direction!

13 Specifications

Index	Items	Parameters
Dimension	L x W (mm)	262x546
	Mainframe H[1] (mm)	611 ~ 866
Weight	Payload	20 ~ 100 kg (44~220 lb)
	Net	Approx. 13.0 kg
Rider Requirement	Applicable Age	16 ~ 50
	Applicable Height	120 ~ 200 cm (3.9 ~ 6.6 ft)
Machine Parameter	Max.Speed	Approx. 16 km/h (10 mph)
	Max. Climbing Angle	Approx. 15°
	Beginner Mode	Can be disabled or reset by App after 1km (0.6mi) riding, accumulative riding can be reset by App
	Applicable Terrain	Harden pavement, flat dirt pavement, down ramp < 15°, staircase < 1cm, groove width < 3cm
	Operation Temp.	-10°C ~ +40°C (-14°F ~ 104°F)
	Storage Temp.	-20°C ~ +45°C (-4°F ~ 113°F)
	IP grade	IP54
Battery Pack	Nominal Voltage (V)	54.8 ~ 36V / 54.8V
	Max.Charging Voltage (V)	63 ~ 42V / 63V
	Nominal Capacity (Wh)	144 / 236
	Smart BMS	Overvoltage/Undervoltage/Short Circuit/Overheating Protection, Auto-Sleep /Wake-up, detailed information of battery can be checked with App
Motor	Nominal Power(W)	350x2
	Max.Power(W)	700x2
	Nominal Power(W)	120
Charger	Nominal Input Voltage(V)	100 ~ 240V ~ 50~60Hz
	Nominal Output Voltage (V)	Approx. 42 / 63
	Nominal Output Current (A)	Approx. 1.0
	Charging Time (H)	Approx. 3.2~5

[1] Mainframe height: refer to distance from ground to the highest end of mainframe.
[2] Typical mileage refers to: test under riding in full power, 70kg(154lb) load, 25°C (77°F) environmental temperature, 15km/h (9.3 mph) average speed on-pavement.

13

Thanks for choosing mini!

Thanks for choosing MINIROBOT (hereinafter referred to as Mini)
Your Mini is a new form of electrical balancing vehicle with smartphone App features.

Enjoy your free riding now!

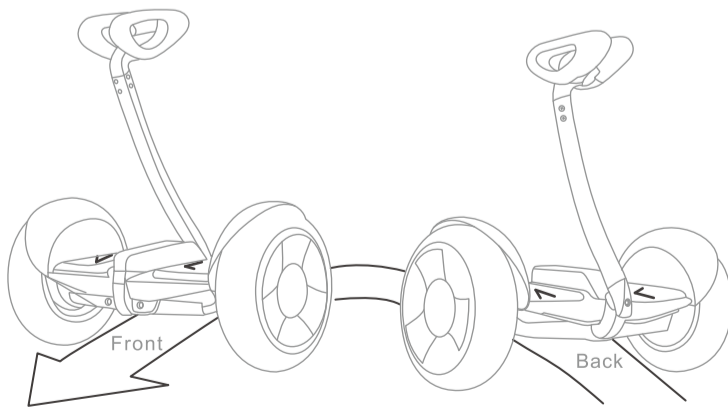

Hint: Please step on/off from the Back!
Or you will risk crash/fall due to wrong steering direction!

13 Specifications

Index	Items	Parameters
Dimension	L x W (mm)	262x546
	Mainframe H[1] (mm)	611 ~ 866
Weight	Payload	20 ~ 100 kg (44~220 lb)
	Net	Approx. 13.0 kg
Rider Requirement	Applicable Age	16 ~ 50
	Applicable Height	120 ~ 200 cm (3.9 ~ 6.6 ft)
Machine Parameter	Max.Speed	Approx. 16 km/h (10 mph)
	Max. Climbing Angle	Approx. 15°
	Beginner Mode	Can be disabled or reset by App after 1km (0.6mi) riding, accumulative riding can be reset by App
	Applicable Terrain	Harden pavement, flat dirt pavement, down ramp < 15°, staircase < 1cm, groove width < 3cm
	Operation Temp.	-10°C ~ +40°C (-14°F ~ 104°F)
	Storage Temp.	-20°C ~ +45°C (-4°F ~ 113°F)
	IP grade	IP54
Battery Pack	Nominal Voltage (V)	54.8 ~ 36V / 54.8V
	Max.Charging Voltage (V)	63 ~ 42V / 63V
	Nominal Capacity (Wh)	144 / 236
	Smart BMS	Overvoltage/Undervoltage/Short Circuit/Overheating Protection, Auto-Sleep /Wake-up, detailed information of battery can be checked with App
Motor	Nominal Power(W)	350x2
	Max.Power(W)	700x2
	Nominal Power(W)	120
Charger	Nominal Input Voltage(V)	100 ~ 240V ~ 50~60Hz
	Nominal Output Voltage (V)	Approx. 42 / 63
	Nominal Output Current (A)	Approx. 1.0
	Charging Time (H)	Approx. 3.2~5

[1] Mainframe height: refer to distance from ground to the highest end of mainframe.
[2] Typical mileage refers to: test under riding in full power, 70kg(154lb) load, 25°C (77°F) environmental temperature, 15km/h (9.3 mph) average speed on-pavement.

13

12 Daily Maintenance

Cleanning and Storing Your Mini

You can use a soft cloth (one used for wiping your glasses) dipped with small amount of water to wipe the mainframe of Mini to remove dirt. The dirt that is hard to wipe out on the plastic surface can be scrubbed with toothbrush after coating it with toothpaste, and then clean with wet cloth. Scratches on plastic parts of vehicle can be polisted by abrasive paper or other abrasive substances.

Hint: Do not wash Mini with alcohol, gas, diesel, acetone or other corrosive and volatile chemical solvent. These substances may danlage the appearance and internal structure. Do not wash the Mini with a power washer or high pressure hose. Make sure that Mini is powered off, the charging cable is plugged out and the rubber cap on the charging port is tightly sealed, otherwise you may expose you to electric shock or cause the device failure.

Store your Mini in a dry and cool place. Do not store it in outdoor environment for a long time. Exposure to sunshine or hot/cold outdoor environment will accelerate the aging of the appearance and the battery life.

Maintenance of Battery Pack

Do not place battery in high-temperature or low-temperature environment which is over 50 or below-20. Do not throw battery pack into fire. Other jterns for attention in maintenance of battery refer to nameplate of battery pack which is below vehicle.

A well maintained battery pack may be in sound performance even after 20 thousand kilometers riding. Charge the battery every time you stop riding and avoid exhausting all the power in daily use. in addition, when using in normal temperature, battery pack can play high distance mileage and performanoe; whileusing in environment below 0, endurance and performance of battery would decline Typically when temperature is -20, distance mileage may be half of normal temperature 25 Distance mileage of battery will reover when temperature rises. You may check the details in App.

Hint: Typically, the fully ehafged battery, if mounted on the Mini, will be exhausted within 120 to 180 days under the stand-by mode; And a low-power battery, if mounted on the Mini, will be exhausted within 30 to 60 days under the stand-by mode. Remember to charge the battey after each riding. Over-draining of power nlay cause un-recoverable damage to the battery intelligent chips inside battery shall record charge-discharge condition of battery, damage caused by over discharge will not be covered under the Limited Warranty. (Non-specialized person are forbidden to disassemble battery pack!)

12

1 Packing List

Knee Control Bar

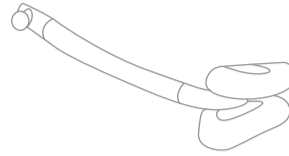

Mainframe

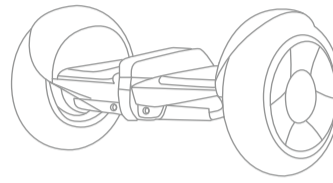

User Manual



Accessories Box



Accessories in the Box

Charger



Extended Air Tap



When taking out the mainframe, please check whether the articles included in the package are as above. You can assemble your new Mini by the following steps after confirming that all the parts are found in the box and in good condition.

Remember to switch off the power of Mini and unplug the charging cable before handling and mounting of any accessory or cleaning of the mainframe.

01

12 Daily Maintenance

Cleanning and Storing Your Mini

You can use a soft cloth (one used for wiping your glasses) dipped with small amount of water to wipe the mainframe of Mini to remove dirt. The dirt that is hard to wipe out on the plastic surface can be scrubbed with toothbrush after coating it with toothpaste, and then clean with wet cloth. Scratches on plastic parts of vehicle can be polisted by abrasive paper or other abrasive substances.

Hint: Do not wash Mini with alcohol, gas, diesel, acetone or other corrosive and volatile chemical solvent. These substances may danlage the appearance and internal structure. Do not wash the Mini with a power washer or high pressure hose. Make sure that Mini is powered off, the charging cable is plugged out and the rubber cap on the charging port is tightly sealed, otherwise you may expose you to electric shock or cause the device failure.

Store your Mini in a dry and cool place. Do not store it in outdoor environment for a long time. Exposure to sunshine or hot/cold outdoor environment will accelerate the aging of the appearance and the battery life.

Maintenance of Battery Pack

Do not place battery in high-temperature or low-temperature environment which is over 50 or below-20. Do not throw battery pack into fire. Other jterns for attention in maintenance of battery refer to nameplate of battery pack which is below vehicle.

A well maintained battery pack may be in sound performance even after 20 thousand kilometers riding. Charge the battery every time you stop riding and avoid exhausting all the power in daily use. in addition, when using in normal temperature, battery pack can play high distance mileage and performanoe; whileusing in environment below 0, endurance and performance of battery would decline Typically when temperature is -20, distance mileage may be half of normal temperature 25 Distance mileage of battery will reover when temperature rises. You may check the details in App.

Hint: Typically, the fully ehafged battery, if mounted on the Mini, will be exhausted within 120 to 180 days under the stand-by mode; And a low-power battery, if mounted on the Mini, will be exhausted within 30 to 60 days under the stand-by mode. Remember to charge the battey after each riding. Over-draining of power nlay cause un-recoverable damage to the battery intelligent chips inside battery shall record charge-discharge condition of battery, damage caused by over discharge will not be covered under the Limited Warranty. (Non-specialized person are forbidden to disassemble battery pack!)

12

1 Packing List

Knee Control Bar

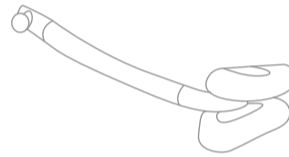

Mainframe

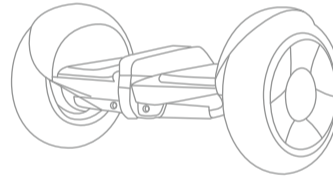

User Manual



Accessories Box

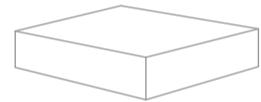

Accessories in the Box

Charger



Extended Air Tap



When taking out the mainframe, please check whether the articles included in the package are as above. You can assemble your new Mini by the following steps after confirming that all the parts are found in the box and in good condition.

Remember to switch off the power of Mini and unplug the charging cable before handling and mounting of any accessory or cleaning of the mainframe.

01

12 Daily Maintenance

Cleanning and Storing Your Mini

You can use a soft cloth (one used for wiping your glasses) dipped with small amount of water to wipe the mainframe of Mini to remove dirt. The dirt that is hard to wipe out on the plastic surface can be scrubbed with toothbrush after coating it with toothpaste, and then clean with wet cloth. Scratches on plastic parts of vehicle can be polisted by abrasive paper or other abrasive substances.

Hint: Do not wash Mini with alcohol, gas, diesel, acetone or other corrosive and volatile chemical solvent. These substances may danlage the appearance and internal structure. Do not wash the Mini with a power washer or high pressure hose. Make sure that Mini is powered off, the charging cable is plugged out and the rubber cap on the charging port is tightly sealed, otherwise you may expose you to electric shock or cause the device failure.

Store your Mini in a dry and cool place. Do not store it in outdoor environment for a long time. Exposure to sunshine or hot/cold outdoor environment will accelerate the aging of the appearance and the battery life.

Maintenance of Battery Pack

Do not place battery in high-temperature or low-temperature environment which is over 50 or below-20. Do not throw battery pack into fire. Other jterns for attention in maintenance of battery refer to nameplate of battery pack which is below vehicle.

A well maintained battery pack may be in sound performance even after 20 thousand kilometers riding. Charge the battery every time you stop riding and avoid exhausting all the power in daily use. in addition, when using in normal temperature, battery pack can play high distance mileage and performanoe; whileusing in environment below 0, endurance and performance of battery would decline Typically when temperature is -20, distance mileage may be half of normal temperature 25 Distance mileage of battery will reover when temperature rises. You may check the details in App.

Hint: Typically, the fully ehafged battery, if mounted on the Mini, will be exhausted within 120 to 180 days under the stand-by mode; And a low-power battery, if mounted on the Mini, will be exhausted within 30 to 60 days under the stand-by mode. Remember to charge the battey after each riding. Over-draining of power nlay cause un-recoverable damage to the battery intelligent chips inside battery shall record charge-discharge condition of battery, damage caused by over discharge will not be covered under the Limited Warranty. (Non-specialized person are forbidden to disassemble battery pack!)

12

1 Packing List

Knee Control Bar

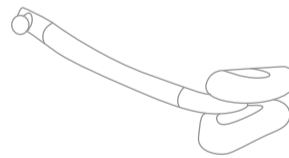

Mainframe

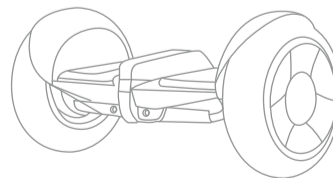

User Manual



Accessories Box



Accessories in the Box

Charger



Extended Air Tap



When taking out the mainframe, please check whether the articles included in the package are as above. You can assemble your new Mini by the following steps after confirming that all the parts are found in the box and in good condition.

Remember to switch off the power of Mini and unplug the charging cable before handling and mounting of any accessory or cleaning of the mainframe.

01

2 MINIROBOT Diagram

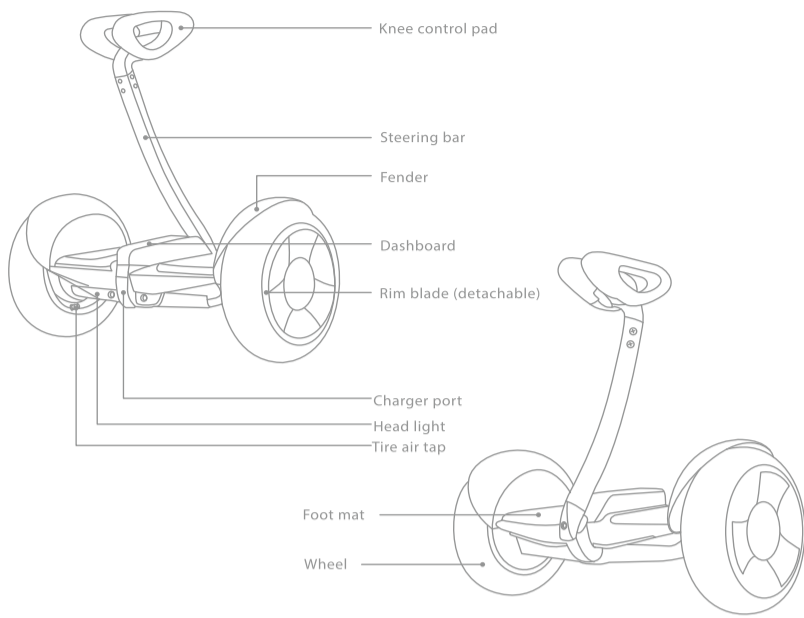

02

11 Lifting and Assistance Mode

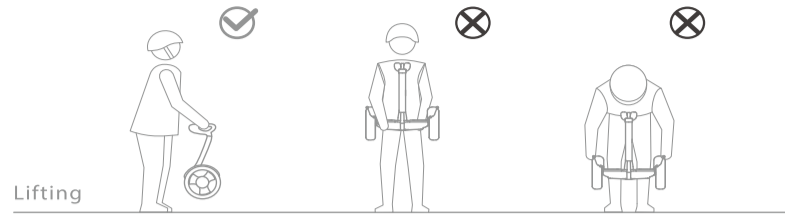

If your Mini is Power ON and in autobalance mode during carrying power output will be cut off automatically when tires are hung in the air for your safety balance mode will be recovered automatically when placing Mini to the ground. Do not lift the Mini by the fender or the main frame, or your finger may be clipped or damaged in fender. Please do as shown on above.



Pull out the draw-bar to enter into the Assistance Mode(automatically when power-on), pushing your Mini flatly may help you move easily under Non-riding mode please lift the Mini when encountering the stairs, do not push it. Please do as shown on above.

11

2 MINIROBOT Diagram

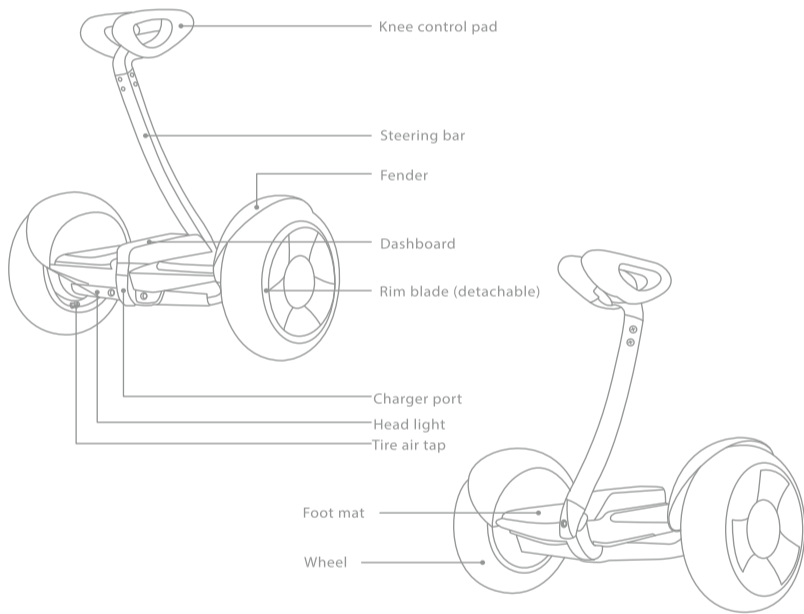

02

11 Lifting and Assistance Mode

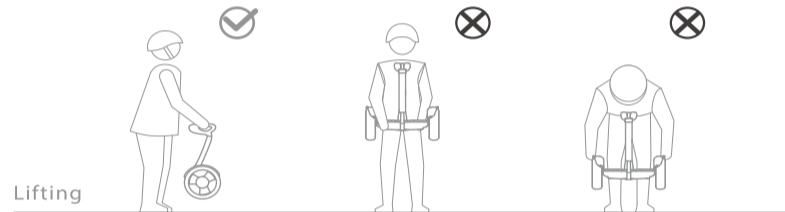

If your Mini is Power ON and in autobalance mode during carrying power output will be cut off automatically when tires are hung in the air for your safety balance mode will be recovered automatically when placing Mini to the ground. Do not lift the Mini by the fender or the main frame, or your finger may be clipped or damaged in fender. Please do as shown on above.



Pull out the draw-bar to enter into the Assistance Mode(automatically when power-on), pushing your Mini flatly may help you move easily under Non-riding mode please lift the Mini when encountering the stairs, do not push it. Please do as shown on above.

11

2 MINIROBOT Diagram

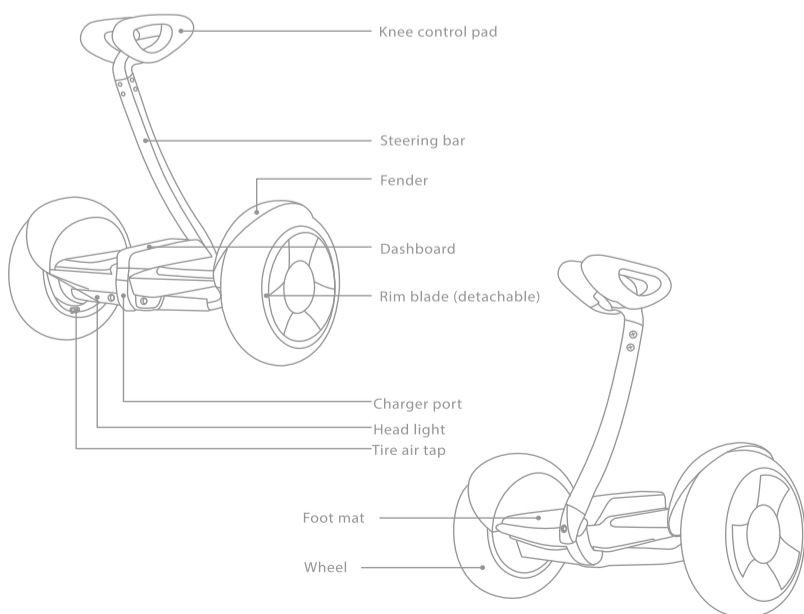

02

11 Lifting and Assistance Mode

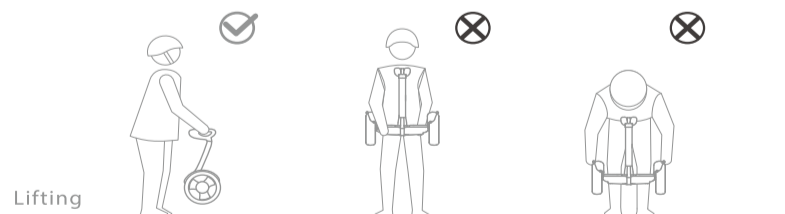

If your Mini is Power ON and in autobalance mode during carrying power output will be cut off automatically when tires are hung in the air for your safety balance mode will be recovered automatically when placing Mini to the ground. Do not lift the Mini by the fender or the main frame, or your finger may be clipped or damaged in fender. Please do as shown on above.



Pull out the draw-bar to enter into the Assistance Mode(automatically when power-on), pushing your Mini flatly may help you move easily under Non-riding mode please lift the Mini when encountering the stairs, do not push it. Please do as shown on above.

11

10 Riding Safety

Mini is an entertainment device, not a transportation vehicle. However, once you ride entering into a public area, your Mini exposes you to risk of injury as the other transportation device does. You are supposed to protect yourself and the others by following this Manual to the maximum extent.

Please understand that you can reduce the risk by following all the instructions and warnings in this Manual, but you cannot eliminate all the risks. Please remember that, whenever you ride the Mini, you risk injury from loss of control, collisions, and falls, when entering into public area like other transportation means even if you fully obey the safe riding instructions. Like all other vehicles, faster speed needs longer brake stopping distance. Rapid brake on smooth surface may lead to wheel slip, losing balance or even falling down. You must be very cautious and always keep a reasonable safe distance with the other people or transportation tools during riding. Be alert and slow down when entering unfamiliar area.

Respect pedestrians by always yielding the right of way, Pass On the left whenever possible. When approaching a pedestrian from the front, stay to the right and slow down. Avoid startling pedestrians. When approaching from behind, announce yourself and slow down to walking speed when passing.

Please strictly comply with safety requirements for riders of this manual in countries and areas without laws and regulations of self-balancing electric vehicle like China MINIROBOT will not be responsible for any property loss, casualties, accidents, legal disputes caused by violation of the safety instructions.

Do not allow anyone to ride the Mini on his/her own unless they have carefully read this Manual. Ask your friends to wear protective articles and assist your friends in beginning the first ride.

Please check if any looseness, damage, tire pressure-lacking or any abnormal conditions before every ride. If continuous abnormal sound or alarms of vehicle occurred during riding, please immediately stop riding. Diagnose your Mini with App and call your reseller for professional instructions or maintenance service.

10

10 Riding Safety

Mini is an entertainment device, not a transportation vehicle. However, once you ride entering into a public area, your Mini exposes you to risk of injury as the other transportation device does. You are supposed to protect yourself and the others by following this Manual to the maximum extent.

Please understand that you can reduce the risk by following all the instructions and warnings in this Manual, but you cannot eliminate all the risks. Please remember that, whenever you ride the Mini, you risk injury from loss of control, collisions, and falls, when entering into public area like other transportation means even if you fully obey the safe riding instructions. Like all other vehicles, faster speed needs longer brake stopping distance. Rapid brake on smooth surface may lead to wheel slip, losing balance or even falling down. You must be very cautious and always keep a reasonable safe distance with the other people or transportation tools during riding. Be alert and slow down when entering unfamiliar area.

Respect pedestrians by always yielding the right of way, Pass On the left whenever possible. When approaching a pedestrian from the front, stay to the right and slow down. Avoid startling pedestrians. When approaching from behind, announce yourself and slow down to walking speed when passing.

Please strictly comply with safety requirements for riders of this manual in countries and areas without laws and regulations of self-balancing electric vehicle like China MINIROBOT will not be responsible for any property loss, casualties, accidents, legal disputes caused by violation of the safety instructions.

Do not allow anyone to ride the Mini on his/her own unless they have carefully read this Manual. Ask your friends to wear protective articles and assist your friends in beginning the first ride.

Please check if any looseness, damage, tire pressure-lacking or any abnormal conditions before every ride. If continuous abnormal sound or alarms of vehicle occurred during riding, please immediately stop riding. Diagnose your Mini with App and call your reseller for professional instructions or maintenance service.

10

10 Riding Safety

Mini is an entertainment device, not a transportation vehicle. However, once you ride entering into a public area, your Mini exposes you to risk of injury as the other transportation device does. You are supposed to protect yourself and the others by following this Manual to the maximum extent.

Please understand that you can reduce the risk by following all the instructions and warnings in this Manual, but you cannot eliminate all the risks. Please remember that, whenever you ride the Mini, you risk injury from loss of control, collisions, and falls, when entering into public area like other transportation means even if you fully obey the safe riding instructions. Like all other vehicles, faster speed needs longer brake stopping distance. Rapid brake on smooth surface may lead to wheel slip, losing balance or even falling down. You must be very cautious and always keep a reasonable safe distance with the other people or transportation tools during riding. Be alert and slow down when entering unfamiliar area.

Respect pedestrians by always yielding the right of way, Pass On the left whenever possible. When approaching a pedestrian from the front, stay to the right and slow down. Avoid startling pedestrians. When approaching from behind, announce yourself and slow down to walking speed when passing.

Please strictly comply with safety requirements for riders of this manual in countries and areas without laws and regulations of self-balancing electric vehicle like China MINIROBOT will not be responsible for any property loss, casualties, accidents, legal disputes caused by violation of the safety instructions.

Do not allow anyone to ride the Mini on his/her own unless they have carefully read this Manual. Ask your friends to wear protective articles and assist your friends in beginning the first ride.

Please check if any looseness, damage, tire pressure-lacking or any abnormal conditions before every ride. If continuous abnormal sound or alarms of vehicle occurred during riding, please immediately stop riding. Diagnose your Mini with App and call your reseller for professional instructions or maintenance service.

10

3 Icons on the Dashboard

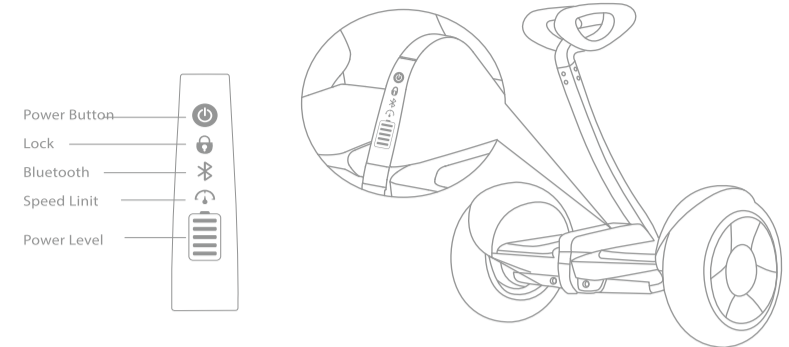

	Power Button	Turn on/off. Mini will automatically shut down when idle for 10 minutes after starting, or when mainframe is put down for over 5 seconds.
	Lock	The Mini will vibrate and buzzer alarm if anyone moves it once Lock Mode activated by App. User's smart phone will automatically alarm at the same time if App is running.
	Bluetooth	The Bluetooth icon flicker to indicate the Bluetooth is ON but not connected to smart phone App; Bluetooth icon light staying ON indicates the App has connected to Mini.
	Speed Limit	The Mini will be limited to lower speed when Speed Limit icon is ON, user will feel Foot Mat tilting up when accelerating. Default speed limits 7km/h, and can be offset and adjusted by App.
	Power Level	Indicates the remaining battery stamina. Whenever the Mini notifies you of an empty Battery condition (power icon flickers), you need to charge your Mini. Use your App to read the remaining power and estimated drivable mileage. When less than 30% your Mini will gradually reduce the max speed limit and when less than 10%, you can only reach 7km/h.

03

3 Icons on the Dashboard

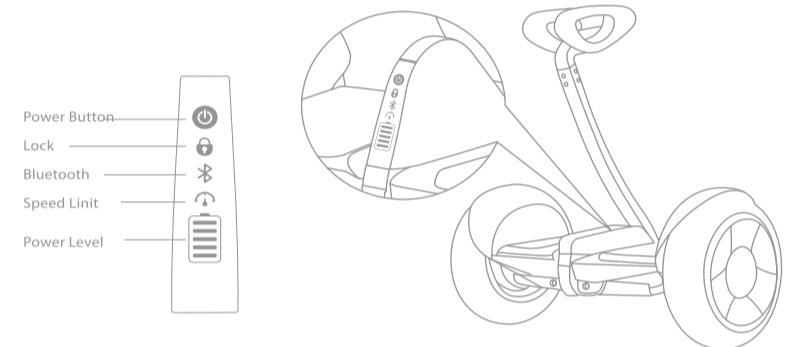

	Power Button	Turn on/off. Mini will automatically shut down when idle for 10 minutes after starting, or when mainframe is put down for over 5 seconds.
	Lock	The Mini will vibrate and buzzer alarm if anyone moves it once Lock Mode activated by App. User's smart phone will automatically alarm at the same time if App is running.
	Bluetooth	The Bluetooth icon flicker to indicate the Bluetooth is ON but not connected to smart phone App; Bluetooth icon light staying ON indicates the App has connected to Mini.
	Speed Limit	The Mini will be limited to lower speed when Speed Limit icon is ON, user will feel Foot Mat tilting up when accelerating. Default speed limits 7km/h, and can be offset and adjusted by App.
	Power Level	Indicates the remaining battery stamina. Whenever the Mini notifies you of an empty Battery condition (power icon flickers), you need to charge your Mini. Use your App to read the remaining power and estimated drivable mileage. When less than 30% your Mini will gradually reduce the max speed limit and when less than 10%, you can only reach 7km/h.

03

3 Icons on the Dashboard

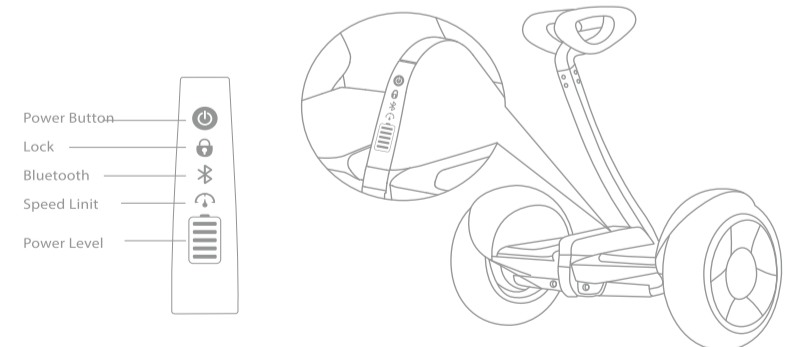

	Power Button	Turn on/off. Mini will automatically shut down when idle for 10 minutes after starting, or when mainframe is put down for over 5 seconds.
	Lock	The Mini will vibrate and buzzer alarm if anyone moves it once Lock Mode activated by App. User's smart phone will automatically alarm at the same time if App is running.
	Bluetooth	The Bluetooth icon flicker to indicate the Bluetooth is ON but not connected to smart phone App; Bluetooth icon light staying ON indicates the App has connected to Mini.
	Speed Limit	The Mini will be limited to lower speed when Speed Limit icon is ON, user will feel Foot Mat tilting up when accelerating. Default speed limits 7km/h, and can be offset and adjusted by App.
	Power Level	Indicates the remaining battery stamina. Whenever the Mini notifies you of an empty Battery condition (power icon flickers), you need to charge your Mini. Use your App to read the remaining power and estimated drivable mileage. When less than 30% your Mini will gradually reduce the max speed limit and when less than 10%, you can only reach 7km/h.

03

4 Assemble Your Mini

Install the steering bar

1 Open the tool free release of the steering bar

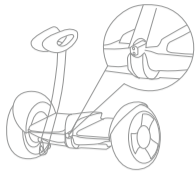

2 Insert the steering bar to the mainframe steering socket

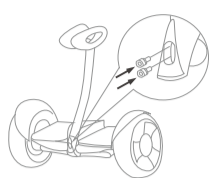

3 Fasten quick release

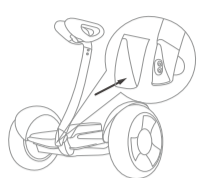

Check the Power ON/OFF status after assembly

For your safety, your Mini is not activated at this moment and it will be beeping after Power-ON with a very low riding speed and steering sensitivity, the non-acticated Mini is not rideable. You need to install the App on smartphone (BLE4.0 or above),connect Mini with Bluetooth, follow the App instructions to activate your Mini.

04

9 Forbidden Behaviour

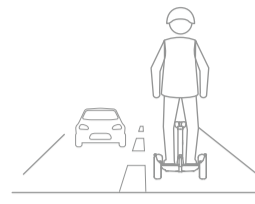

⊗ Riding into motorway

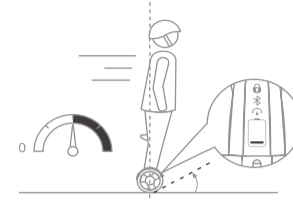

⊗ Riding or accelerating when the Mini is alarming or when foot mat tilting up



⊗ Riding in >2cm puddle

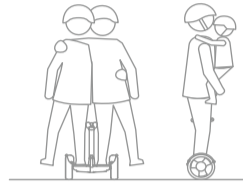

⊗ Riding with 1+ persons on it, especially catring a baby

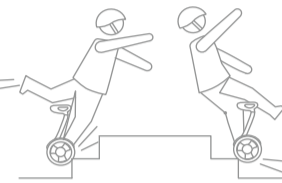

⊗ Riding to ascend or descend stairs / escalators



⊗ Rapid acceleration Pendulum movement

09

4 Assemble Your Mini

Install the steering bar

1 Open the tool free release of the steering bar

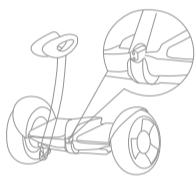

2 Insert the steering bar to the mainframe steering socket

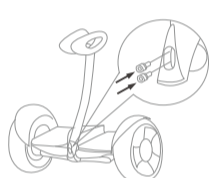

3 Fasten quick release

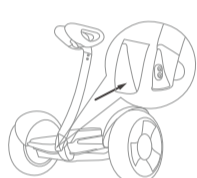

Check the Power ON/OFF status after assembly

For your safety, your Mini is not activated at this moment and it will be beeping after Power-ON with a very low riding speed and steering sensitivity, the non-acticated Mini is not rideable. You need to install the App on smartphone (BLE4.0 or above),connect Mini with Bluetooth, follow the App instructions to activate your Mini.

04

9 Forbidden Behaviour

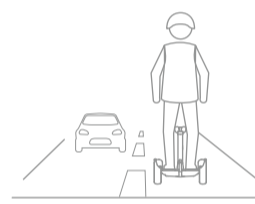

⊗ Riding into motorway

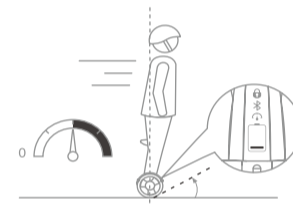

⊗ Riding or accelerating when the Mini is alarming or when foot mat tilting up



⊗ Riding in >2cm puddle

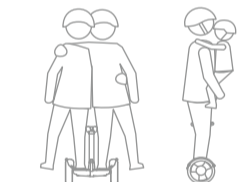

⊗ Riding with 1+ persons on it, especially catring a baby

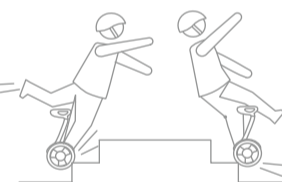

⊗ Riding to ascend or descend stairs / escalators



⊗ Rapid acceleration Pendulum movement

09

4 Assemble Your Mini

Install the steering bar

1 Open the tool free release of the steering bar

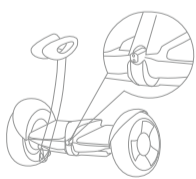

2 Insert the steering bar to the mainframe steering socket

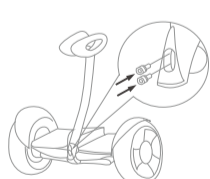

3 Fasten quick release

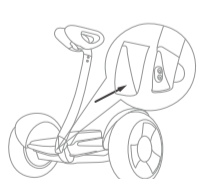

Check the Power ON/OFF status after assembly

For your safety, your Mini is not activated at this moment and it will be beeping after Power-ON with a very low riding speed and steering sensitivity, the non-acticated Mini is not rideable. You need to install the App on smartphone (BLE4.0 or above),connect Mini with Bluetooth, follow the App instructions to activate your Mini.

04

9 Forbidden Behaviour

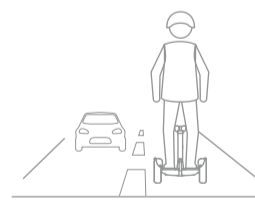

⊗ Riding into motorway

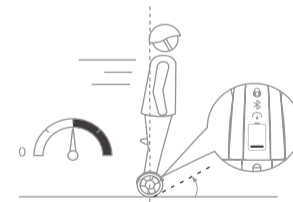

⊗ Riding or accelerating when the Mini is alarming or when foot mat tilting up



⊗ Riding in >2cm puddle

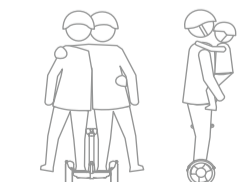

⊗ Riding with 1+ persons on it, especially catring a baby

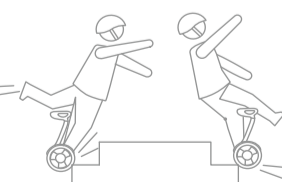

⊗ Riding to ascend or descend stairs / escalators



⊗ Rapid acceleration Pendulum movement

09

8 Warning

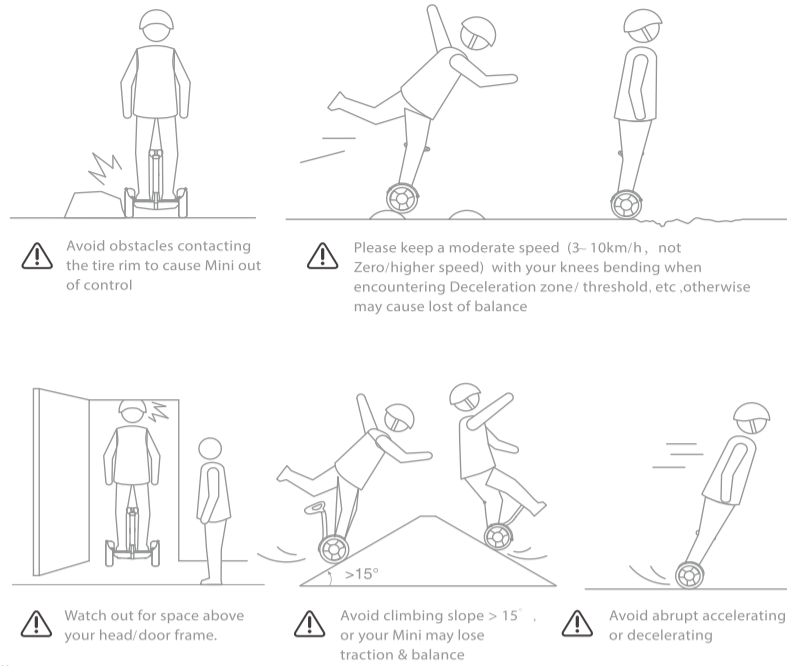

08

5 First Ride

There is safety risk for a new rider when learning to ride the Mini. It is strongly recommended that you follow the Safety Instructions before your first ride

You will need to Use your Smartphone(Android or iOS)to install App to watch the Safety Instructions and follow the New User Tutorials before your first ride. Scan the QR code to install App.

App scanning and install (IOS 5 or above, Android 4.3 or above)

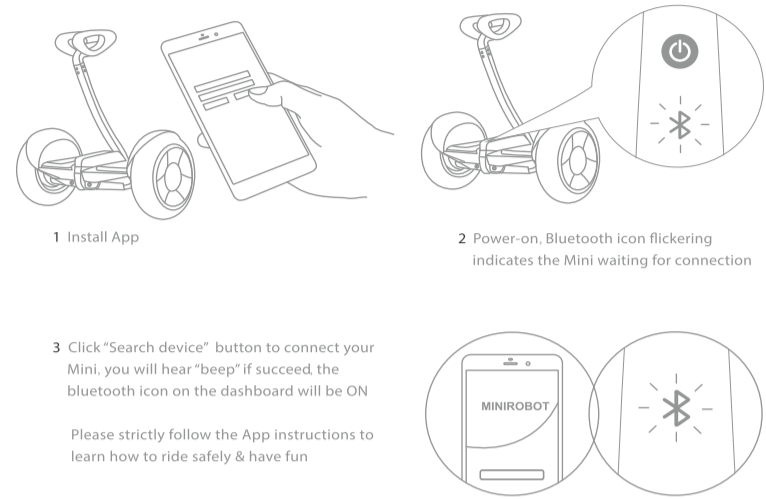

05

8 Warning

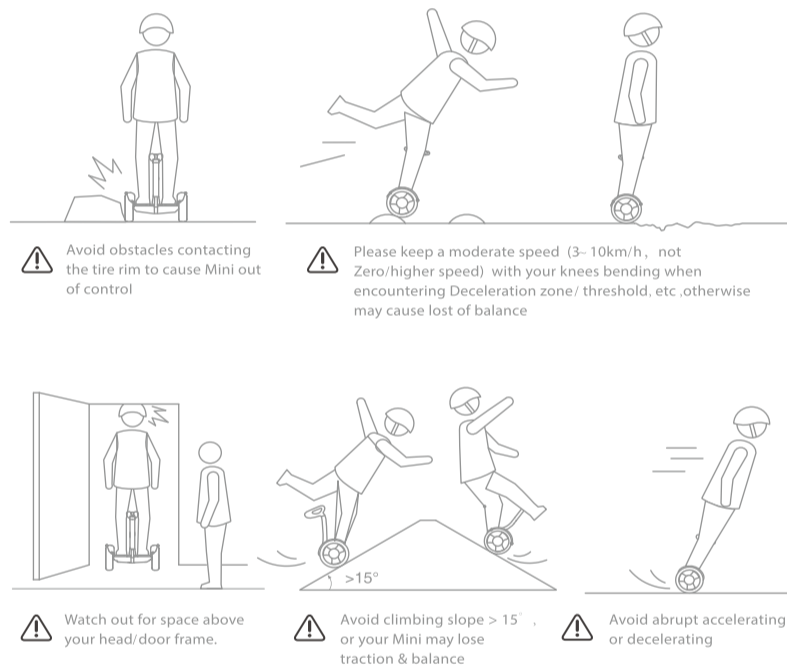

08

5 First Ride

There is safety risk for a new rider when learning to ride the Mini. It is strongly recommended that you follow the Safety Instructions before your first ride

You will need to Use your Smartphone(Android or iOS)to install App to watch the Safety Instructions and follow the New User Tutorials before your first ride. Scan the QR code to install App.

App scanning and install (IOS 5 or above, Android 4.3 or above)

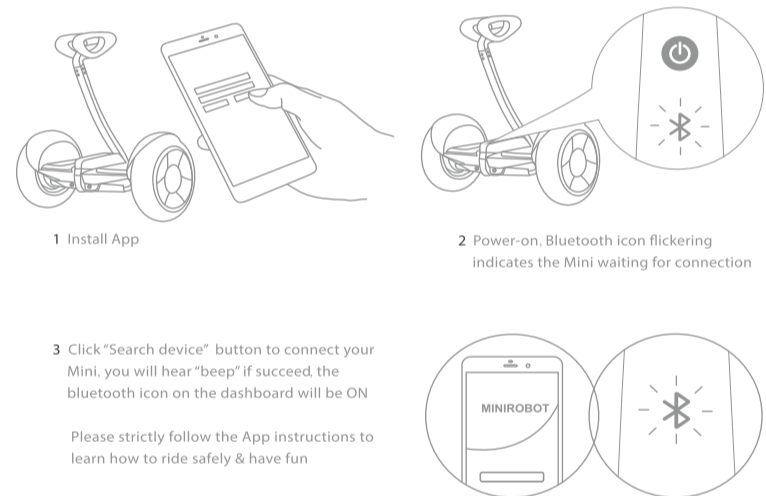

05

8 Warning

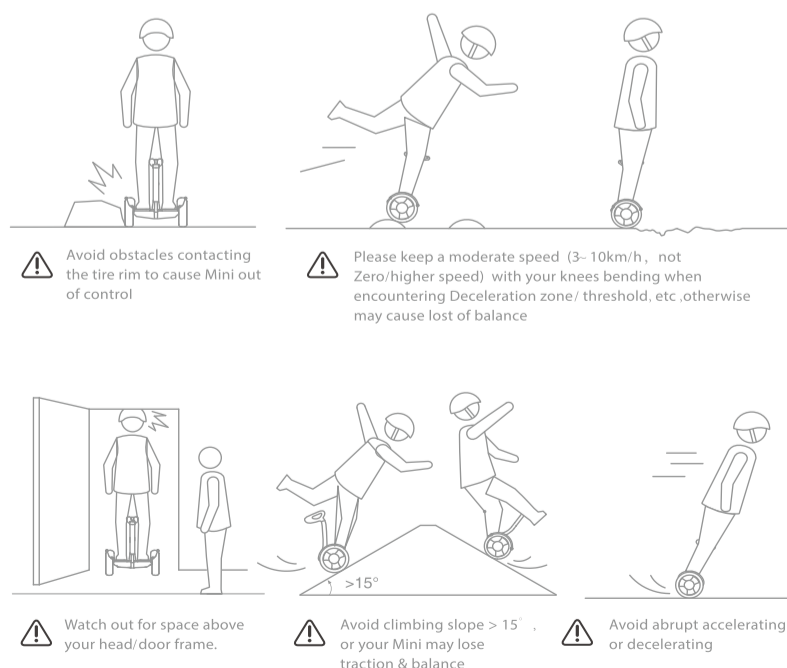

08

5 First Ride

There is safety risk for a new rider when learning to ride the Mini. It is strongly recommended that you follow the Safety Instructions before your first ride

You will need to Use your Smartphone(Android or iOS)to install App to watch the Safety Instructions and follow the New User Tutorials before your first ride. Scan the QR code to install App.

App scanning and install (IOS 5 or above, Android 4.3 or above)

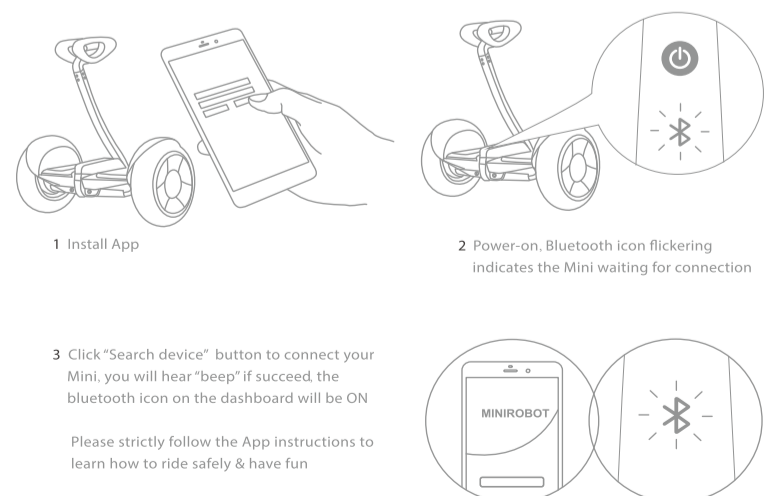

05

6 Charging

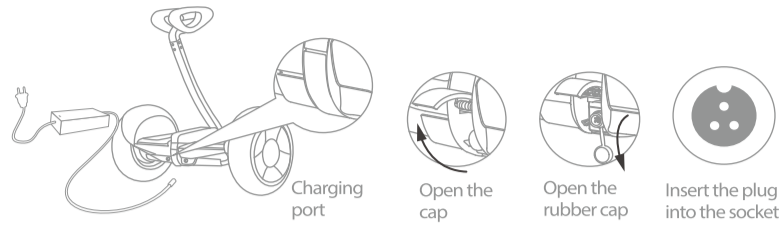

06

7 Learn to Ride



1 Please step on with other's assistance on an open area for your first ride.
Please noted you need to step on from the back

2 Step on the foot mat with one foot standing firm, avoid touching the knee control pad with your shank or knees and cause steering

3 Slowly transfer your weight to your foot on the mat, and step up onto the other mat



4 Step on foot mat with both feet and relax, looking straight ahead, avoid severe wagging

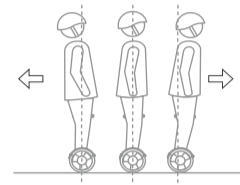

5 Step on foot mat with both feet and slowly lean your body forward or backward to control your moving

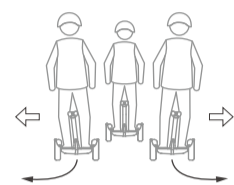

6 Slowly lean against the steering bar / knee pads left and right to make a turn

07

6 Charging

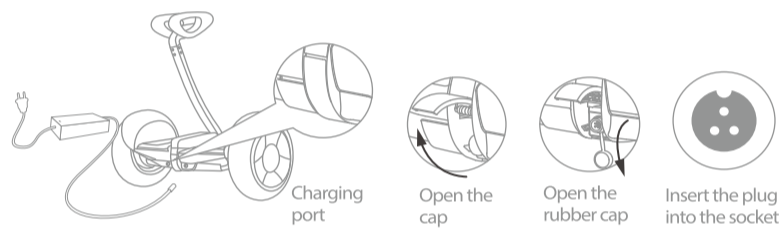

06

7 Learn to Ride



1 Please step on with other's assistance on an open area for your first ride.
Please noted you need to step on from the back

2 Step on the foot mat with one foot standing firm, avoid touching the knee control pad with your shank or knees and cause steering

3 Slowly transfer your weight to your foot on the mat, and step up onto the other mat



4 Step on foot mat with both feet and relax, looking straight ahead, avoid severe wagging

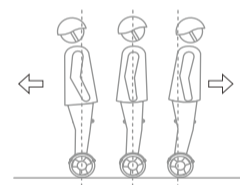

5 Step on foot mat with both feet and slowly lean your body forward or backward to control your moving

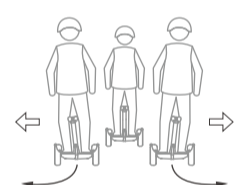

6 Slowly lean against the steering bar / knee pads left and right to make a turn

07

6 Charging

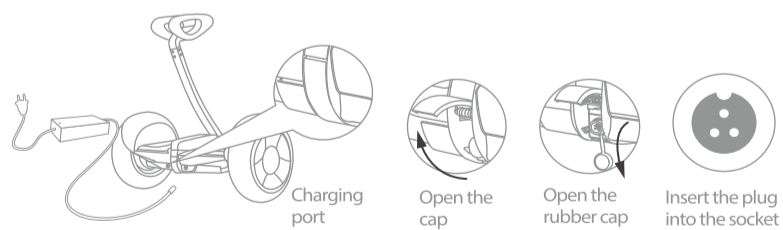

06

7 Learn to Ride



1 Please step on with other's assistance on an open area for your first ride.
Please noted you need to step on from the back

2 Step on the foot mat with one foot standing firm, avoid touching the knee control pad with your shank or knees and cause steering

3 Slowly transfer your weight to your foot on the mat, and step up onto the other mat



4 Step on foot mat with both feet and relax, looking straight ahead, avoid severe wagging

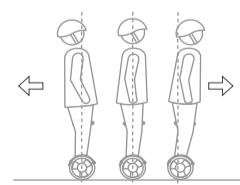

5 Step on foot mat with both feet and slowly lean your body forward or backward to control your moving

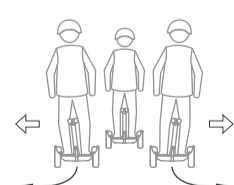

6 Slowly lean against the steering bar / knee pads left and right to make a turn

07

This device complies with part 15 of the FCC Rules. Operation is subject to the following two conditions: (1) This device may not cause harmful interference, and (2) this device must accept any interference received, including interference that may cause undesired operation.

Any Changes or modifications not expressly approved by the party responsible for compliance could void the user's authority to operate the equipment.

Note: This equipment has been tested and found to comply with the limits for a Class B digital device, pursuant to part 15 of the FCC Rules. These limits are designed to provide reasonable protection against harmful interference in a residential installation. This equipment generates uses and can radiate radio frequency energy and, if not installed and used in accordance with the instructions, may cause harmful interference to radio communications. However, there is no guarantee that interference will not occur in a particular installation. If this equipment does cause harmful interference to radio or television reception, which can be determined by turning the equipment off and on, the user is encouraged to try to correct the interference by one or more of the following measures:

- Reorient or relocate the receiving antenna.
- Increase the separation between the equipment and receiver.
- Connect the equipment into an outlet on a circuit different from that to which the receiver is connected.
- Consult the dealer or an experienced radio/TV technician for help.