

## TEST REPORT

### FCC Rules Part 15.249

**Report Reference No.....:** MTEB24010067-R

**FCC ID..... :** 2A9G9-HD962

Compiled by

( position+printed name+signature)..: File administrators Alisa Luo

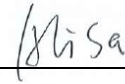

Supervised by

( position+printed name+signature)..: Test Engineer Sunny Deng



Approved by

( position+printed name+signature)..: Manager Yvette Zhou

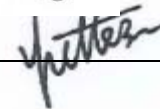

Date of issue.....: **Jan. 08,2024**

**Representative Laboratory Name .:** Shenzhen Most Technology Service Co., Ltd.

Address .....: No.5, 2nd Langshan Road, North District, Hi-tech Industrial Park,  
Nanshan, Shenzhen, Guangdong, China.

**Applicant's name.....:** Thin Air Brands, LLC

Address .....: 5332 Talavera Place, Parker, CO 80134, USA

**Test specification/ Standard .....** FCC Part15 Subpart C, Section 15.249

TRF Originator.....: Shenzhen Most Technology Service Co., Ltd.

**Shenzhen Most Technology Service Co., Ltd. All rights reserved.**

This publication may be reproduced in whole or in part for non-commercial purposes as long as the Shenzhen Most Technology Service Co., Ltd. is acknowledged as copyright owner and source of the material. Shenzhen Most Technology Service Co., Ltd. takes no responsibility for and will not assume liability for damages resulting from the reader's interpretation of the reproduced material due to its placement and context.

**Test item description .....** Hyper Drive RC Shark

Trade Mark .....: N/A

Model/Type reference.....: HD962

Listed Models .....: N/A

Modulation Type.....: GFSK

Operation Frequency.....: 2410-2470MHz

Hardware version : V1.0

Software version : V1.0

Rating : 3VDC (AA \* 2)

Result.....: **PASS**

# TEST REPORT

Equipment under Test : Hyper Drive RC Shark

Model /Type : HD962

Listed Models : N/A

Remark : N/A

Applicant : **Thin Air Brands, LLC**

Address : 5332 Talavera Place, Parker, CO 80134, USA

Manufacturer : /

Address : /

<b>Test Result:</b>	<b>PASS</b>
---------------------	-------------

The test report merely corresponds to the test sample.  
It is not permitted to copy extracts of these test result without the written permission of the test laboratory.

## Contents

<b>1. REVISION HISTORY .....</b>	<b>4</b>
<b>2. TEST STANDARDS .....</b>	<b>5</b>
<b>3. SUMMARY .....</b>	<b>6</b>
3.1. General Remarks .....	6
3.2. Product Description .....	6
3.3. Equipment Under Test .....	6
3.4. Short description of the Equipment under Test (EUT) .....	6
3.5. EUT operation mode .....	7
3.6. Block Diagram of Test Setup .....	7
3.7. Test Item (Equipment Under Test) Description* .....	7
3.8. Auxiliary Equipment (AE) Description .....	8
3.9. Antenna Information* .....	8
3.10. EUT configuration .....	8
3.11. Modifications .....	8
<b>4. TEST ENVIRONMENT .....</b>	<b>9</b>
4.1. Address of the test laboratory .....	9
4.2. Environmental conditions .....	9
4.3. Test Description .....	10
4.4. Statement of the measurement uncertainty .....	10
4.5. Equipments Used during the Test .....	11
<b>5. TEST CONDITIONS AND RESULTS .....</b>	<b>12</b>
5.1. AC Power Conducted Emission .....	12
5.2. Radiated Spurious Emissions and Bandedge Emission .....	13
5.3. 20dB Bandwidth .....	20
5.4. Antenna Requirement .....	22
<b>6. TEST SETUP PHOTOS OF THE EUT .....</b>	<b>23</b>
<b>7. EXTERNAL AND INTERNAL PHOTOS OF THE EUT .....</b>	<b>24</b>

## 1. Revision History

Revision	Issue Date	Revisions	Revised By
00	2024.01.08	Initial Issue	Alisa Luo

## **2. TEST STANDARDS**

The tests were performed according to following standards:

The tests were performed according to following standards:

[FCC Rules Part 15.249](#): Operation within the bands 902-928 MHz, 2400-2483.5 MHz, 5725-5875 MHz, and 24.0-24.25 GHz.

[RSS-210](#): Licence-Exempt Radio Apparatus: Category I Equipment

[ANSI C63.10-2013](#): American National Standard for Testing Unlicensed Wireless Devices.

### 3. SUMMARY

#### 3.1. General Remarks

Date of receipt of test sample	:	2024.01.03
Testing commenced on	:	2024.01.04
Testing concluded on	:	2024.01.08

#### 3.2. Product Description

Product Name:	Hyper Drive RC Shark
Model/Type reference:	HD962
Power Supply:	3VDC (AA * 2)
Testing sample ID:	MTYP03873
<b>FCC Test :</b>	
Modulation:	GFSK
Operation frequency:	2410-2470MHz
Channel number:	31
Antenna type:	Wired Antenna
Antenna gain:	1dBi

#### 3.3. Equipment Under Test

##### Power supply system utilised

Power supply voltage	:	<input type="radio"/> 230V / 50 Hz	<input type="radio"/> 120V / 60Hz
		<input type="radio"/> 12 V DC	<input type="radio"/> 24 V DC
		<input checked="" type="radio"/> Other (specified in blank below)	

DC3V

#### 3.4. Short description of the Equipment under Test (EUT)

This is a Hyper Drive RC Shark For more details, refer to the user's manual of the EUT.

### 3.5. EUT operation mode

The Applicant provides communication tools software to control the EUT for staying in continuous transmitting (Duty Cycle more than 98%) and receiving mode for testing .There are 31 channels provided to the EUT. Channel 00/16/30 was selected to test.

Channel	Frequency(MHz)	Channel	Frequency(MHz)
<b>0</b>	<b>2410</b>	20	2450
1	2413	21	2453
2	2414	22	2454
3	2417	23	2457
4	2418	24	2458
5	2421	25	2461
6	2422	26	2462
7	2425	27	2465
8	2426	28	2466
9	2429	29	2469
10	2430	<b>30</b>	<b>2470</b>
11	2433		
12	2434		
13	2437		
14	2438		
15	2441		
<b>16</b>	<b>2442</b>		
17	2445		
18	2446		
19	2449		

### 3.6. Block Diagram of Test Setup

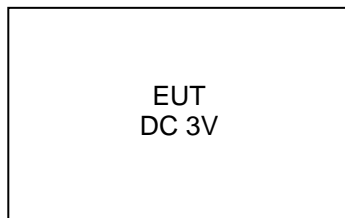

### 3.7. Test Item (Equipment Under Test) Description\*

Short designation	EUT Name	EUT Description	Serial number	Hardware status	Software status
EUT A	/	/	/	/	/
EUT B	/	/	/	/	/

\*: declared by the applicant. According to customers information EUTs A and B are the same devices. Power on the configuration tool device R103A(R103A inserted into a Notebook PC ), which is used to configure the module R100H device to enter engineering testing mode. The physical object of R103A is shown in the figure. To use this device, you need to install the corresponding USB to serial driver, such as the CP210x included in the email\_VCP\_Windows.rar.



### 3.8. Auxiliary Equipment (AE) Description

AE short designation	EUT Name (if available)	EUT Description	Serial number (if available)	Software (if used)
AE 1	/	/	/	/
AE 2	/	/	/	/

### 3.9. Antenna Information\*

Short designation	Antenna Name	Antenna Type	Frequency Range	Serial number	Antenna Peak Gain
Antenna 1	---	Wired Antenna	2442MHz	---	1dBi
Antenna 2	/	/	/	/	/

\*: declared by the applicant.

### 3.10. EUT configuration

The following peripheral devices and interface cables were connected during the measurement:

- supplied by the manufacturer

- Supplied by the lab

<input type="radio"/>	ADAPTER	M/N:	
<input type="radio"/>		Manufacturer:	

### 3.11. Modifications

No modifications were implemented to meet testing criteria.



## 4. TEST ENVIRONMENT

### 4.1. Address of the test laboratory

#### **Shenzhen Most Technology Service Co., Ltd.**

No.5, 2nd Langshan Road, North District, Hi-tech Industrial Park, Nanshan, Shenzhen, Guangdong, China.  
The 3m-Semi anechoic test site fulfils CISPR 16-1-4 according to ANSI C63.4:2014 and CISPR 16-1-4:2010 SVSWR requirement for radiated emission above 1GHz.

#### **Test Facility**

The test facility is recognized, certified, or accredited by the following organizations:

#### **FCC-Registration No.: 0031192610**

Shenzhen Most Technology Service Co., Ltd. EMC Laboratory has been registered and fully described in a report filed with the (FCC) Federal Communications Commission. The acceptance letter from the FCC is maintained in our files.

#### **A2LA-Lab Cert. No.: 6343.01**

Shenzhen Most Technology Service Co., Ltd. EMC Laboratory has been accredited by A2LA for technical competence in the field of electrical testing, and proved to be in compliance with ISO/IEC 17025: 2005 General Requirements for the Competence of Testing and Calibration Laboratories and any additional program requirements in the identified field of testing.

### 4.2. Environmental conditions

Radiated Emission:

Temperature:	23 ° C
Humidity:	48 %
Atmospheric pressure:	950-1050mbar

Conducted testing:

Temperature:	24 ° C
Humidity:	45 %
Atmospheric pressure:	950-1050mbar

### 4.3. Test Description

FCC and IC Requirements		
FCC Part 15.203	Antenna Requirement	N/A
FCC Part 15.207	AC Power Conducted Emission	N/A
FCC Part 15. 15.249(a)	Field strength of the Fundamental signal	PASS
FCC Part 15.209/15.249(a)	Spurious Emissions	PASS
FCC Part 15.205/15.249(d)	Band edge Emissions	PASS
FCC Part 15.215(c)	20dB Occupied Bandwidth	PASS

Remark:

1. The measurement uncertainty is not included in the test result.
2. NA = Not Applicable; NP = Not Performed

### 4.4. Statement of the measurement uncertainty

The data and results referenced in this document are true and accurate. The reader is cautioned that there may be errors within the calibration limits of the equipment and facilities. The measurement uncertainty was calculated for all measurements listed in this test report acc. to CISPR 16 - 4 „Specification for radio disturbance and immunity measuring apparatus and methods – Part 4: Uncertainty in EMC Measurements“ and is documented in the Shenzhen Most Technology Service Co., Ltd. quality system acc. to DIN EN ISO/IEC 17025. Furthermore, component and process variability of devices similar to that tested may result in additional deviation. The manufacturer has the sole responsibility of continued compliance of the device.

Hereafter the best measurement capability for Shenzhen Most Technology Service Co., Ltd. is reported:

Test	Range	Measurement Uncertainty	Notes
Radiated Emission	30~1000MHz	4.10 dB	(1)
Radiated Emission	1~18GHz	4.32 dB	(1)
Radiated Emission	18-40GHz	5.54 dB	(1)
Conducted Disturbance	0.15~30MHz	3.12 dB	(1)

- (1) This uncertainty represents an expanded uncertainty expressed at approximately the 95% confidence level using a coverage factor of k=2.

#### 4.5. Equipments Used during the Test

Item	Equipment	Manufacturer	Model No.	Serial No.	Last Cal.	Cal. Interval
1.	L.I.S.N.	R&S	ENV216	100093	2023/03/17	1 Year
2	Three-phase artificial power network	Schwarzback Mess	NNLK8129	8129178	2023/03/17	1 Year
3.	Receiver	R&S	ESCI	100492	2023/03/17	1 Year
4	Receiver	R&S	ESPI	101202	2023/03/17	1 Year
5	Spectrum analyzer	Agilent	9020A	MT-E306	2023/03/17	1 Year
6	Bilong Antenna	Sunol Sciences	JB3	A121206	2023/03/17	1 Year
7	Horn antenna	HF Antenna	HF Antenna	MT-E158	2023/03/17	1 Year
8	Loop antenna	Beijing Daze	ZN30900B	/	2023/03/17	1 Year
9	Horn antenna	R&S	OBH100400	26999002	2023/03/17	1 Year
10	Wireless Communication Test Set	R&S	CMW500	/	2023/03/17	1 Year
11	Spectrum analyzer	R&S	FSP	100019	2023/03/17	1 Year
12	High gain antenna	Schwarzbeck	LB-180400KF	MT-E389	2023/03/17	1 Year
13	Preamplifier	Schwarzbeck	BBV 9743	MT-E390	2023/03/17	1 Year
14	Pre-amplifier	EMCI	EMC051845S E	MT-E391	2023/03/17	1 Year
15	Pre-amplifier	Agilent	83051A	MT-E392	2023/03/17	1 Year
16	High pass filter unit	Tonscend	JS0806-F	MT-E393	2023/03/17	1 Year
17	RF Cable(below1GHz)	Times	9kHz-1GHz	MT-E394	2023/03/17	1 Year
18	RF Cable(above 1GHz)	Times	1-40G	MT-E395	2023/03/17	1 Year
19	RF Cable (9KHz-40GHz)	Tonscend	170660	N/A	2023/03/17	1 Year

Note: 1. The Cal.Interval was one year.

## 5. TEST CONDITIONS AND RESULTS

### 5.1. AC Power Conducted Emission

#### TEST CONFIGURATION

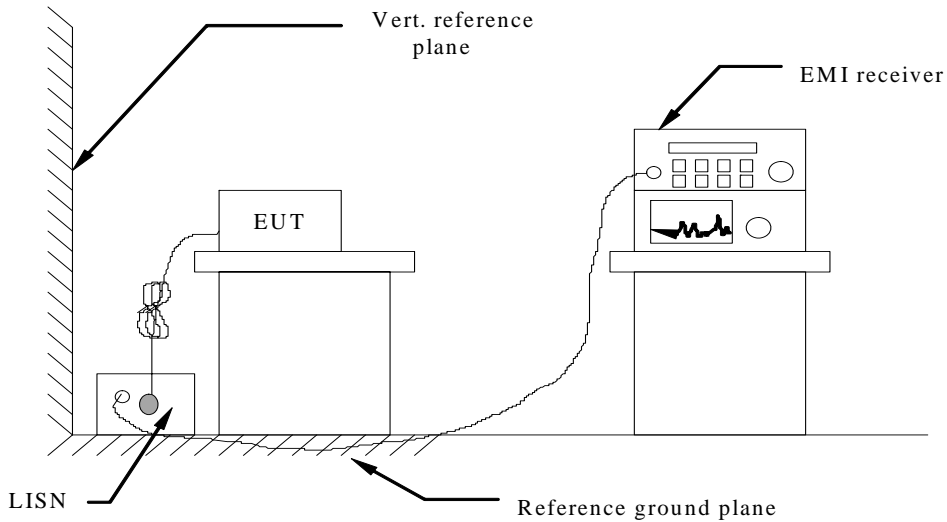

#### TEST PROCEDURE

- 1 The equipment was set up as per the test configuration to simulate typical actual usage per the user's manual. The EUT is a tabletop system, a wooden table with a height of 0.8 meters is used and is placed on the ground plane as per ANSI C63.10-2013.
- 2 Support equipment, if needed, was placed as per ANSI C63.10-2013
- 3 All I/O cables were positioned to simulate typical actual usage as per ANSI C63.10-2013
- 4 The EUT received DC5V power, the adapter received AC120V/60Hz power through a Line Impedance Stabilization Network (LISN) which supplied power source and was grounded to the ground plane.
- 5 All support equipments received AC power from a second LISN, if any.
- 6 The EUT test program was started. Emissions were measured on each current carrying line of the EUT using a spectrum Analyzer / Receiver connected to the LISN powering the EUT. The LISN has two monitoring points: Line 1 (Hot Side) and Line 2 (Neutral Side). Two scans were taken: one with Line 1 connected to Analyzer / Receiver and Line 2 connected to a 50 ohm load; the second scan had Line 1 connected to a 50 ohm load and Line 2 connected to the Analyzer / Receiver.
- 7 Analyzer / Receiver scanned from 150 KHz to 30MHz for emissions in each of the test modes.
- 8 During the above scans, the emissions were maximized by cable manipulation.

#### AC Power Conducted Emission Limit

For unintentional device, according to RSS Gen 8.8 and § 15.207(a) Line Conducted Emission Limits is as following:

Frequency range (MHz)	Limit (dBuV)	
	Quasi-peak	Average
0.15-0.5	66 to 56*	56 to 46*
0.5-5	56	46
5-30	60	50

\* Decreases with the logarithm of the frequency.

#### TEST RESULTS

N/A

## 5.2. Radiated Spurious Emissions and Bandedge Emission

### TEST CONFIGURATION

Frequency range 9 KHz – 30MHz

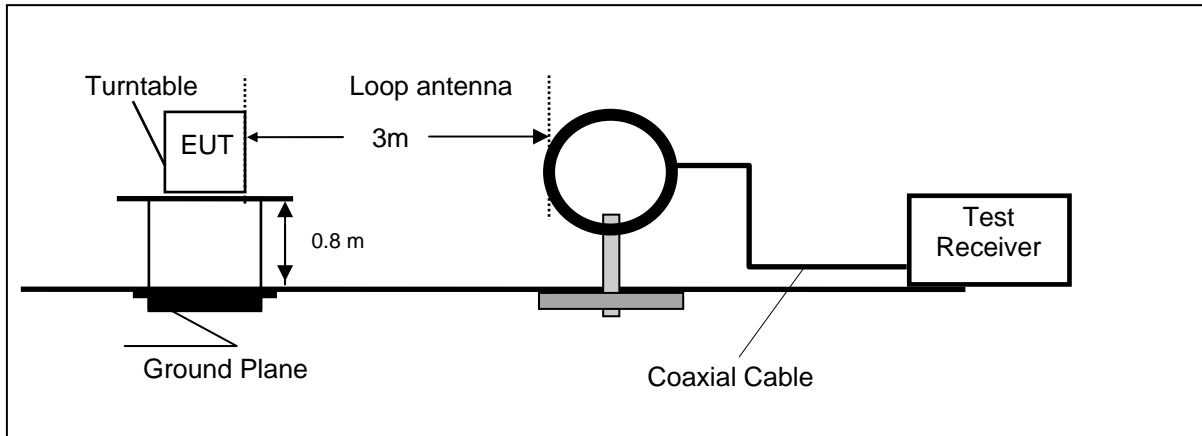

Frequency range 30MHz – 1000MHz

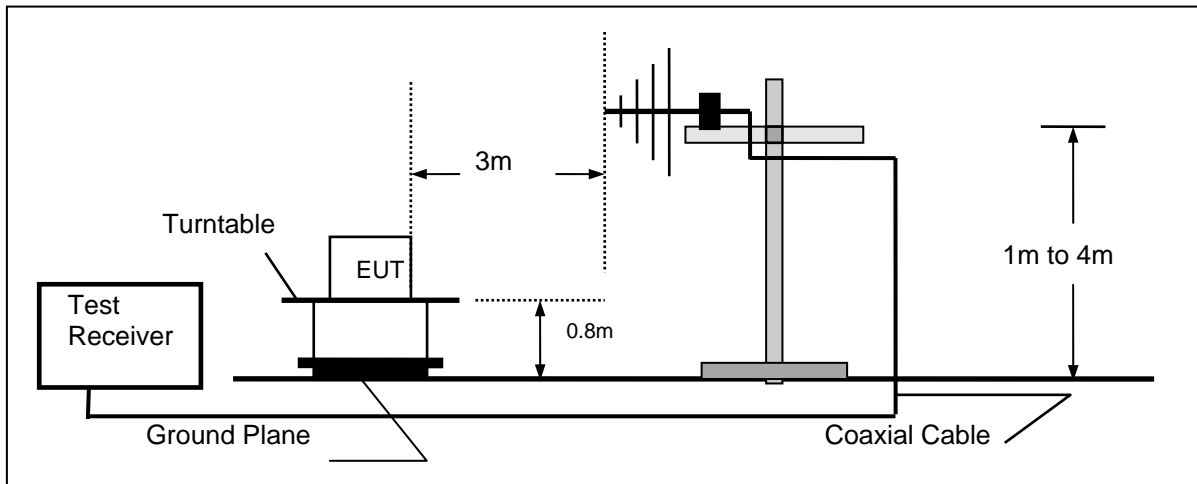

Frequency range above 1GHz-25GHz

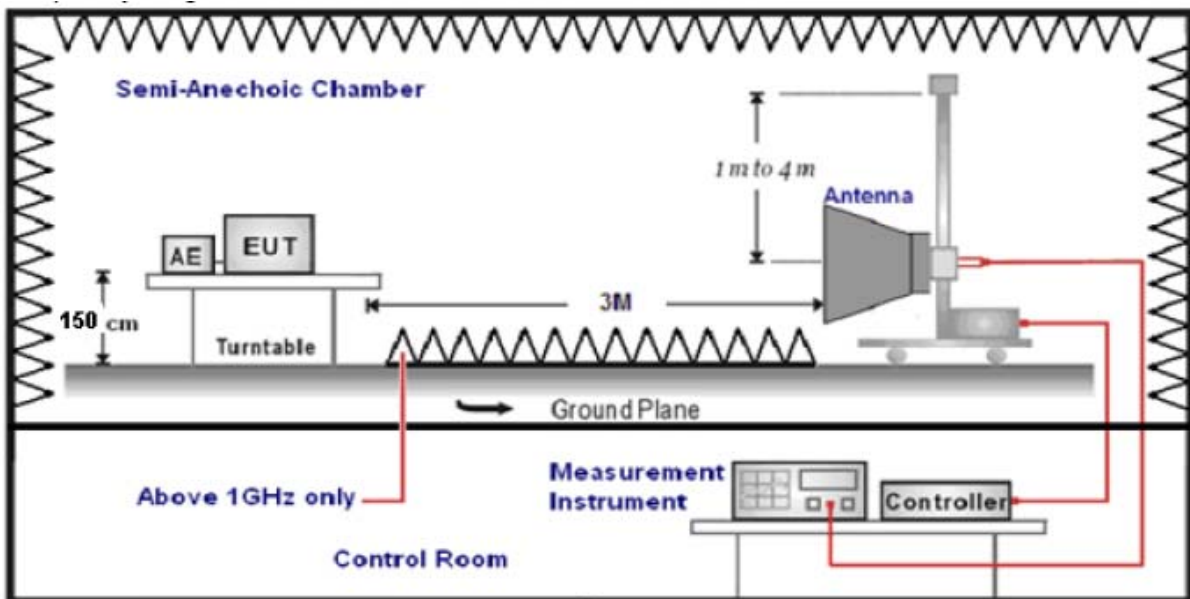

### TEST PROCEDURE

- a. 1) Below 1G: The EUT was placed on the top of a rotating table 0.8 meters above the ground at a 3 meter semi-anechoic chamber. The table was rotated 360 degrees to determine the position of the highest radiation.  
 2) Above 1G: The EUT was placed on the top of a rotating table 1.5 meters above the ground at a 3 meter semi-anechoic chamber. The table was rotated 360 degrees to determine the position of the highest radiation.  
 Note: For the radiated emission test above 1GHz:  
 Place the measurement antenna away from each area of the EUT determined to be a source of emissions at the specified measurement distance, while keeping the measurement antenna aimed at the source of emissions at each frequency of significant emissions, with polarization oriented for maximum response. The measurement antenna may have to be higher or lower than the EUT, depending on the radiation pattern of the emission and staying aimed at the emission source for receiving the maximum signal. The final measurement antenna elevation shall be that which maximizes the emissions. The measurement antenna elevation for maximum emissions shall be restricted to a range of heights of from 1 m to 4 m above the ground or reference ground plane.
  - b. The EUT was set 3 meters away from the interference-receiving antenna, which was mounted on the top of a variable-height antenna tower.
  - c. The antenna height is varied from one meter to four meters above the ground to determine the maximum value of the field strength. Both horizontal and vertical polarizations of the antenna are set to make the measurement.
  - d. For each suspected emission, the EUT was arranged to its worst case and then the antenna was tuned to heights from 1 meter to 4 meters (for the test frequency of below 30MHz, the antenna was tuned to heights 1 meter) and the rotatable table
  - e. was turned from 0 degrees to 360 degrees to find the maximum reading.
  - e. The test-receiver system was set to Peak Detect Function and Specified Bandwidth with Maximum Hold Mode.
  - f. If the emission level of the EUT in peak mode was 10dB lower than the limit specified, then testing could be stopped and the peak values of the EUT would be reported. Otherwise the emissions that did not have 10dB margin would be re-tested one by one using peak, quasi-peak or average method as specified and then reported in a data sheet.
  - g. Test the EUT in the lowest channel,the middle channel,the Highest channel
  - h. The radiation measurements are performed in X, Y, Z axis positioning for Transmitting mode,And found the X axis positioning which it is worse case.
- Repeat above procedures until all frequencies measured was complete.

**RADIATION LIMIT**

Limit:(Spurious Emissions and band edge)

Frequency	Field strength (microvolt/meter)	Limit (dBuV/m )	Remark	Measurement distance (m)
0.009MHz-0.490MHz	2400/F(kHz)	-	-	300
0.490MHz-1.705MHz	24000/F(kHz)	-	-	30
1.705MHz-30MHz	30	-	-	30
30MHz-88MHz	100	40.0	Quasi-peak	3
88MHz-216MHz	150	43.5	Quasi-peak	3
216MHz-960MHz	200	46.0	Quasi-peak	3
960MHz-1GHz	500	54.0	Quasi-peak	3
Above 1GHz	500	54.0	Average	3

- Note: 1) 15.35(b), Unless otherwise specified, the limit on peak radio frequency emissions is 20dB above the maximum permitted average emission limit applicable to the equipment under test. This peak limit applies to the total peak emission level radiated by the device.  
 2) Emissions radiated outside of the specified frequency bands, except for harmonics, shall be attenuated by at least 50 dB below the level of the fundamental or to the general radiated emission limits in Section 15.209, whichever is the lesser attenuation.

Limit:(Field strength of the fundamental signal)

Frequency	Limit (dBuV/m @3m)	Remark
2410-2470MHz	114	PEAK
	94	AVG

**Test Results****Radiated Spurious Emissions***Notes:*

- 1). Measuring frequencies from 9 KHz - 10<sup>th</sup> harmonic (ex. 26.5GHz), No emission found between lowest internal used/generated frequency to 30 MHz.*
- 2). Radiated emissions measured in frequency range from 9 KHz - 10<sup>th</sup> harmonic (ex. 26.5GHz) were made with an instrument using Peak detector mode.*
- 3). 18~25 GHz at least have 20dB margin. No recording in the test report.*

For 30MHz-1GHz

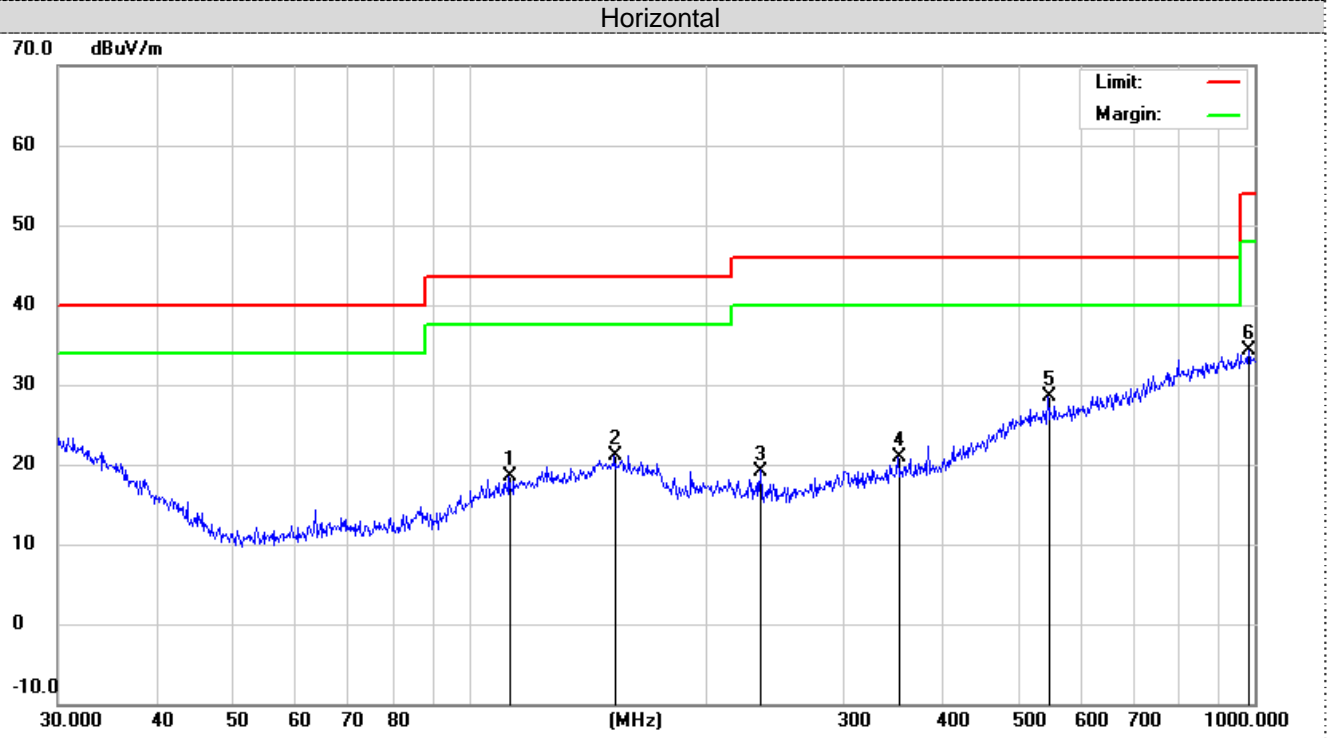

No.	Mk.	Freq.	Reading Level	Correct Factor	Measurement	Limit	Over	Antenna Height	Table Degree	
		MHz	dBuV	dB	dBuV/m	dBuV/m	dB	cm	degree	Comment
1		112.5244	3.49	14.98	18.47	43.50	-25.03	QP	200	231
2		153.2004	3.61	17.57	21.18	43.50	-22.32	QP	200	35
3		234.9909	4.98	14.22	19.20	46.00	-26.80	QP	200	321
4		351.7079	4.35	16.48	20.83	46.00	-25.17	QP	200	288
5	*	545.1826	5.30	23.20	28.50	46.00	-17.50	QP	200	184
6		982.6200	4.55	29.83	34.38	54.00	-19.62	QP	200	101

\*:Maximum data    x:Over limit    !:over margin



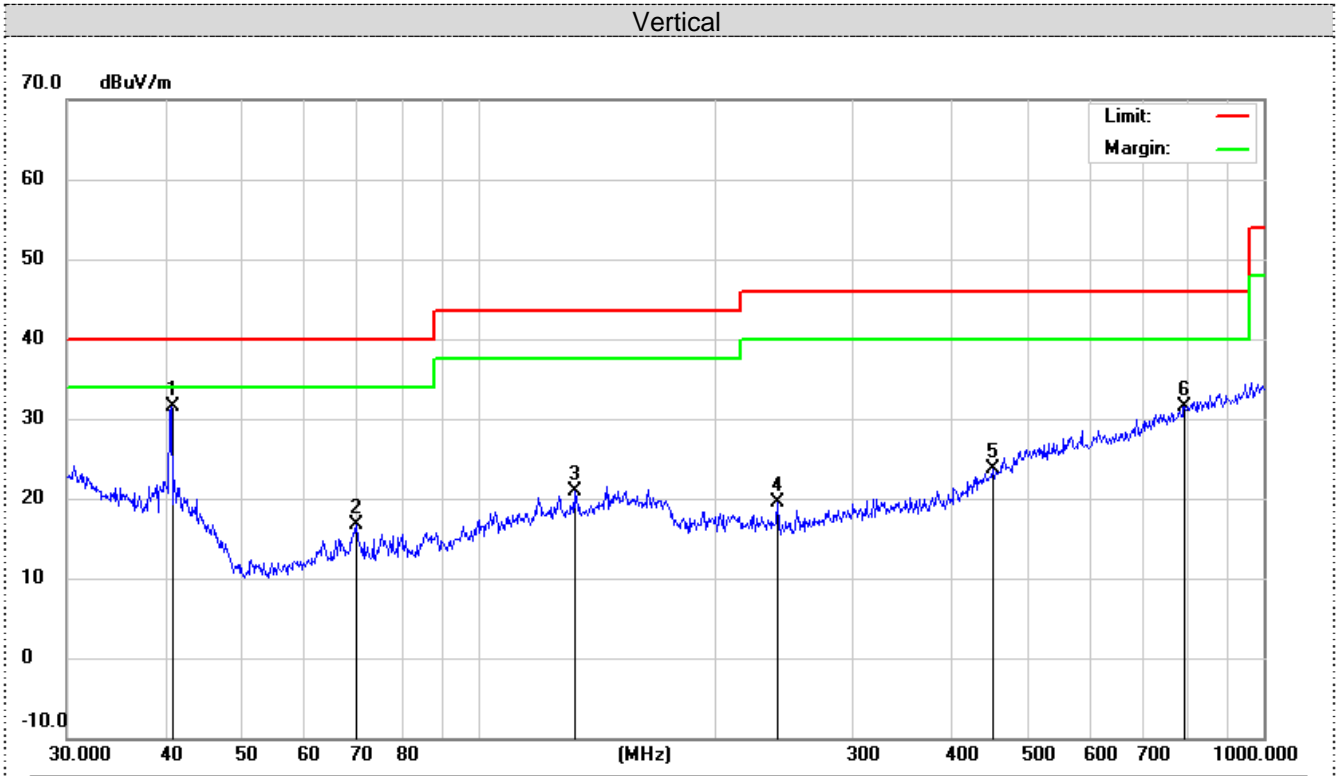

No.	Mk.	Freq. MHz	Reading Level dBuV	Correct Factor dB	Measure- ment dBuV/m	Limit dBuV/m	Over dB	Antenna Height cm	Table Degree	Comment
1	*	40.7016	18.20	13.34	31.54	40.00	-8.46	QP	100	35
2		70.0902	7.49	9.31	16.80	40.00	-23.20	QP	100	88
3		132.6850	4.64	16.20	20.84	43.50	-22.66	QP	100	138
4		240.8303	5.36	14.06	19.42	46.00	-26.58	QP	100	188
5		452.7197	3.52	20.19	23.71	46.00	-22.29	QP	100	236
6		793.3958	3.81	27.71	31.52	46.00	-14.48	QP	100	284

\*:Maximum data    x:Over limit    !:over margin

Frequency	Antenna	Reading	Cable Loss	Ant Factor	Amplifier	Results	Limits	Det.
(MHz)	Pol.	(dBuV/m)	(dB)	(dB)	(dB)	(dBuV/m)	(dBuV/m)	Mode
2410	H	88.86	3.32	27.49	36.22	83.45	114	Peak
2410	H	68.75	3.32	27.49	36.22	63.34	94	AVG
2410	V	89.26	3.32	27.49	36.22	83.85	114	Peak
2410	V	68.99	3.32	27.49	36.22	63.58	94	AVG
2442	H	87.55	3.35	27.47	36.28	82.09	114	Peak
2442	H	67.81	3.35	27.47	36.28	62.35	94	AVG
2442	V	88.26	3.35	27.47	36.28	82.8	114	Peak
2442	V	66.39	3.35	27.47	36.28	60.93	94	AVG
2470	H	83.99	3.38	27.45	36.34	78.48	114	Peak
2470	H	64.39	3.38	27.45	36.34	58.88	94	AVG
2470	V	85.98	3.38	27.45	36.34	80.47	114	Peak
2470	V	65.98	3.38	27.45	36.34	60.47	94	AVG

For Above 1 GHz

Frequency	Antenna	Reading	Cable Loss	Ant Factor	Amplifier	Results	Limits	Det.
(MHz)	Pol.	(dBuV/m)	(dB)	(dB)	(dB)	(dBuV/m)	(dBuV/m)	Mode
4840	H	59.62	6.98	31.42	36.5	61.52	74	PK
4840	H	41.23	6.98	31.42	36.5	43.13	54	AV
4840	V	60.29	6.98	31.42	36.5	62.19	74	PK
4840	V	40.28	6.98	31.42	36.5	42.18	54	AV
4884	H	60.11	7.58	30.98	36.5	62.17	74	PK
4884	H	39.99	7.58	30.98	36.5	42.05	54	AV
4884	V	60.58	7.58	30.98	36.5	62.64	74	PK
4884	V	40.18	7.58	30.98	36.5	42.24	54	AV
4940	H	58.76	7.8	31.47	36.2	61.83	74	PK
4940	H	42.36	7.8	31.47	36.2	45.43	54	AV
4940	V	58.74	7.8	31.47	36.2	61.81	74	PK
4940	V	41.02	7.8	31.47	36.2	44.09	54	AV

REMARKS:

1. 1:Result = Reading + Cable Loss +Ant Factor –Amplifier
2. -- Mean the PK detector measured value is below average limit.
3. The other emission levels were very low against the limit.

**Bandedge Emission****GFSK**

Frequency(MHz):			2410		Polarity:		HORIZONTAL		
Frequency (MHz)	Emission Level (dBuV/m)		Limit (dBuV/m)	Margin (dB)	Raw Value (dBuV)	Antenna Factor (dB/m)	Cable Factor (dB)	Pre-amplifier (dB)	Correction Factor (dB/m)
2410.00	58.84	PK	74	15.16	64.25	27.49	3.32	36.22	-5.41
2410.00	41.24	AV	54	12.76	46.65	27.49	3.32	36.22	-5.41
Frequency(MHz):			2410		Polarity:		VERTICAL		
Frequency (MHz)	Emission Level (dBuV/m)		Limit (dBuV/m)	Margin (dB)	Raw Value (dBuV)	Antenna Factor (dB/m)	Cable Factor (dB)	Pre-amplifier (dB)	Correction Factor (dB/m)
2410.00	57.01	PK	74	16.99	62.42	27.49	3.32	36.22	-5.41
2410.00	39.86	AV	54	14.14	45.27	27.49	3.32	36.22	-5.41
Frequency(MHz):			2470		Polarity:		HORIZONTAL		
Frequency (MHz)	Emission Level (dBuV/m)		Limit (dBuV/m)	Margin (dB)	Raw Value (dBuV)	Antenna Factor (dB/m)	Cable Factor (dB)	Pre-amplifier (dB)	Correction Factor (dB/m)
2470.00	56.05	PK	74	17.95	61.56	27.45	3.38	36.34	-5.51
2470.00	41.24	AV	54	12.76	46.75	27.45	3.38	36.34	-5.51
Frequency(MHz):			2470		Polarity:		VERTICAL		
Frequency (MHz)	Emission Level (dBuV/m)		Limit (dBuV/m)	Margin (dB)	Raw Value (dBuV)	Antenna Factor (dB/m)	Cable Factor (dB)	Pre-amplifier (dB)	Correction Factor (dB/m)
2470.00	56.29	PK	74	17.71	61.8	27.45	3.38	36.34	-5.51
2470.00	41.22	AV	54	12.78	46.73	27.45	3.38	36.34	-5.51

## REMARKS:

1. Emission level (dBuV/m) =Raw Value (dBuV)+Correction Factor (dB/m)
2. Correction Factor (dB/m) = Antenna Factor (dB/m)+Cable Factor (dB)- Pre-amplifier
3. Margin value = Limit value- Emission level.
4. -- Mean the PK detector measured value is below average limit.

### 5.3. 20dB Bandwidth

#### TEST CONFIGURATION

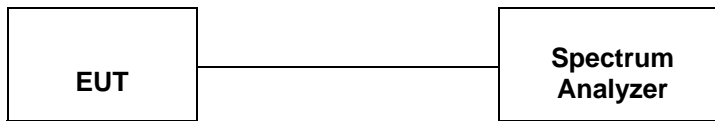

#### TEST PROCEDURE

1: The transmitter output was connected to the spectrum analyzer through an attenuator, the path loss was compensated to the results for each measurement.

2: Set to the maximum power setting and enable the EUT transmit continuously.

3: Use the following spectrum analyzer settings:

Span = approximately 2 to 3 times the 20 dB bandwidth, centered on a test channel  $RBW \geq 1\%$  of the 20 dB bandwidth,  $VBW \geq RBW$

Sweep = auto, Detector function = peak, Trace = max hold

4: Measure and record the results in the test report.

#### TEST RESULTS

Modulation	Channel Frequency (MHz)	99% OBW (MHz)	20dB bandwidth (MHz)	Result
GFSK	2410	2.2433	2.478	Pass
	2442	2.0853	2.410	
	2470	1.7967	2.031	

Test plot as follows:

GFSK Modulation

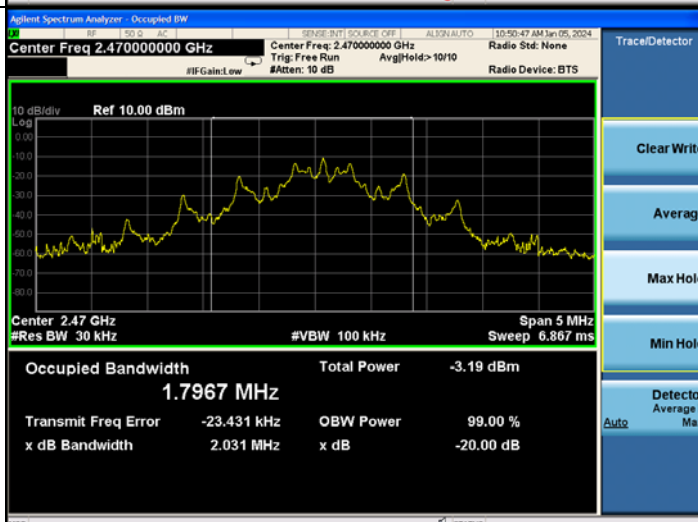
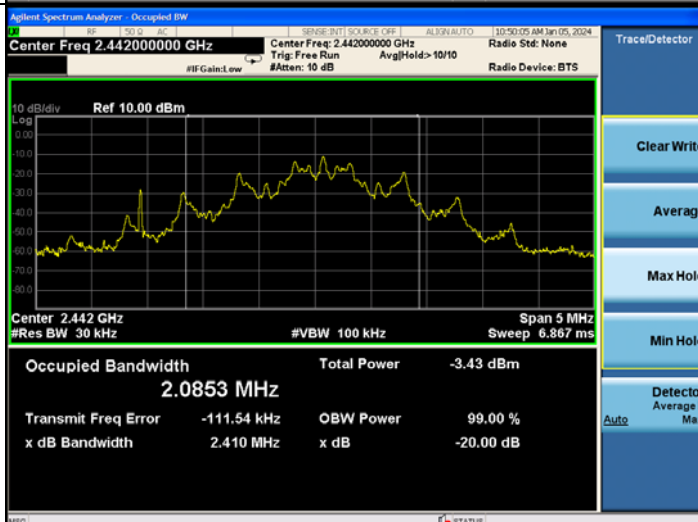
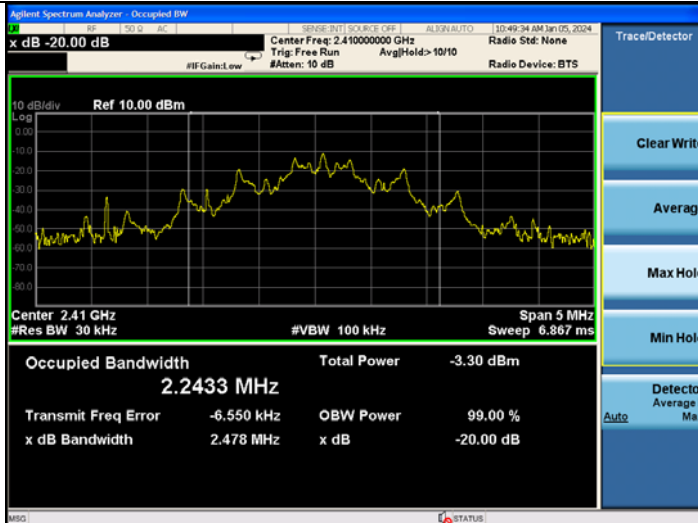

#### 5.4. Antenna Requirement

##### **Standard Applicable**

For intentional device, according to FCC 47 CFR Section 15.203, an intentional radiator shall be designed to ensure that no antenna other than that furnished by the responsible party shall be used with the device.

##### **Refer to statement below for compliance**

The manufacturer may design the unit so that the user can replace a broken antenna, but the use of a standard antenna jack or electrical connector is prohibited. Further, this requirement does not apply to intentional radiators that must be professionally installed.

##### **Antenna Connected Construction**

The directional gains of antenna used for transmitting is 1dBi, and the antenna is a Wired Antenna connect to PCB board and no consideration of replacement. Please see EUT photo for details.

Results: Compliance.

## 6. Test Setup Photos of the EUT

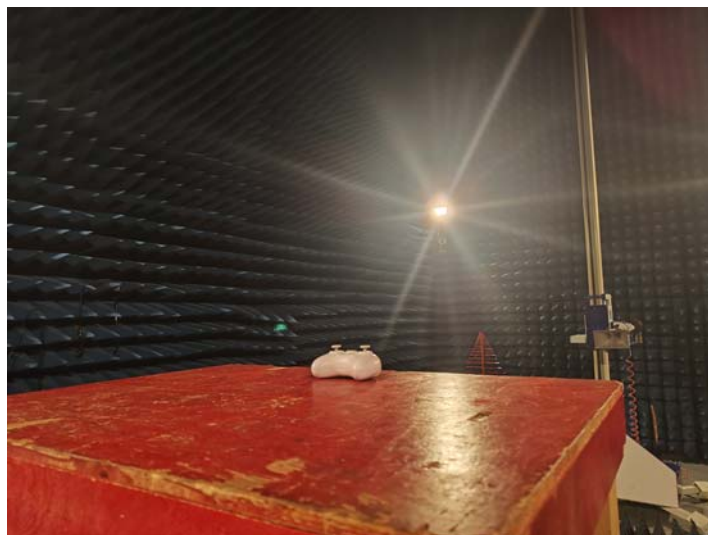

## **7. External and Internal Photos of the EUT**

See related photo report.

.....**End of Report**.....