

承认书

SPECIFICATION FOR APPROVAL

客户名称 (CUSTOMER):

客户料号 (CUSTOMER P/N): K1000

品名 (DESCRIPTION):

DATE: 2021-7-28

规格 (SPECIFICATION): G40开单槽+背胶引线长25mm

REV.NO.: A0

部门	确认/日期	审核/日期	批准/日期	(盖公司公章)
品质	董晚红 2021/7/28	吕惠 2021/7/28	韦函满 2021/7/28	
工程	何伟华 2021/7/28	韦立红 2021/7/28	韦立红 2021/7/28	

备注:

承认签核、盖章

部门	确认/日期	审核/日期	批准/日期	(盖公司公章)
开发工程师				
采购				
品质				

备注:

1.MECHANICAL DIMENSION (UNIT:mm)

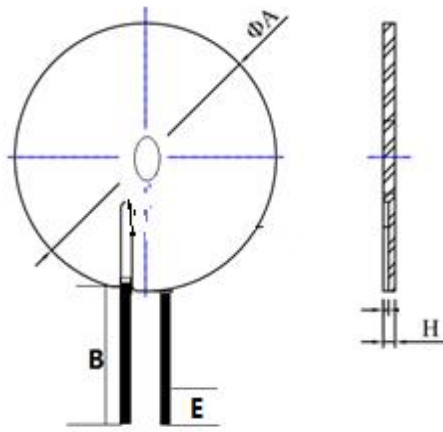

2. SCHEMATICS:

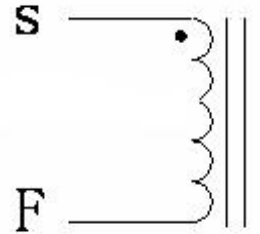

1. Coil attached disk,
disk size
40 + / - 1 mm,
Order trough.
2. Outlet position of the coil
1-2 ts wrap tape;
3. The bottom of the disk should be pasted with 3M adhesive.

A	B	E	H	
40±1.0	25±3	3±1.5	1.8MAX	

3.WINDING:

STEP	START-FINISH	WIRE TYPE	TURNS	TAPE	REMARK
N1	S-F	Hot air wire 0.08*24*2Pmm 2UEW	10TS (Ref)		

4. ELECTRICAL SPECIFICATION:

ITEM	L	DCR	L	Q	HI-POT
TEST	Coil plus disk	S-F			
CON	100KHz, 0.25V	AT 25°C			
SPEC	6.5uH±10%	95mΩ Max			

5.BILF OF MATERIAL:

NO.	ITEM	MATERIAL SPECIFICATION	MANUFACTURER	SGS NO.
1	Hot air line	Hot air line 0.08*24 strands	NANJINGJINNINGCO,LTD	
2	Lead-free solder article	Lead-free solder article	QIAODO	
3	disk	Ø G40 * 0.55 slot opening sheet zinc manganese hard disk	TAIYI CO.,LTD	
4	glue	Yellow glue 9999	LIANCHENG CO.,LTD	
5	The high temperature tape	8mm wide high temperature adhesive paper	CUDAK CO.,LTD	
6	The back glue	39.5 * 0.1 3 m glue	CUDAK CO.,LTD	

HRSW ELECTRONICS CO.,LTD	PART NO	
	TITLE	G40 single slot + adhesive lead length 56mm

DRAWN BY	CHECKED BY	APPROVED BY
HE WEI HUA	WEI LI HONG	WEI LI HONG

6. SAMPLE TEST DATA									
6.1 DIMENSION TEST (UNIT: mm)									
TEST ITEM	A	B	E	H					
SPEC	40±1.0	25±3	3±1.5	1.8MAX					
1	49.8	25.6	3.50	1.50					
2	49.9	25.4	3.60	1.20					
3	49.5	24.9	3.70	1.30					
4	50	25.8	3.80	1.28					
5	49.86	24.98	4.00	1.46					
6									
7									
8									
9									
10									
MAX	50.00	25.80	4.00	1.50					
MIN	49.50	24.90	3.50	1.20					
AVERAGE	49.81	25.34	3.72	1.35					
6.2 ELECTRICAL TEST									
TEST ITEM	L		DCR	IDC		Q	HI-POT		
	S-F		S-F						
TEST COND	100KHz/0.25v		AT 25°C						
SPEC	6.5uH ±10%		95mΩ (Max)						
1	6.51		70.00						
2	6.52		72.00						
3	6.49		70.10						
4	6.53		70.05						
5	6.52		70.16						
6									
7									
8									
9									
10									
MAX	6.53		72.00						
MIN	6.49		70.00						
AVERAGE	6.51		70.46						
HRSW ELECTRONICS CO., LTD					PART NO			G40开单槽+背胶引线长 25mm	
					TITLE				
DRAWN BY			CHECKED BY			APPROVED BY			
何伟华			韦立红			韦立红			