

SPECIFICATION FOR APPROVAL

CUSTOMER:

轩宏达科技

ROHS

CUSTOMER P/N:

TITLE: SMD INDUCTANCE

DATE: 2023-3-2

HRSW MODLE : G45开槽+背胶 15mm

REV. NO. : A0

PLEASE RETURN TO US COPY OF "SPECIFICATION FOR APPROVAL "WITH YOUR APPROVED

APPROVED <input type="checkbox"/>	REJECTED <input type="checkbox"/>	“✓”
CUSTOMER'S SIGNATURE <hr/>		

REV	DATE	CHANGED CONTENTENTS &CHANGED REASONS	DRAWN	CHECKED	APPROVED
A0	2023/3/2	NEW RELEASE	谢超	何伟华	韦立红

深圳轩宏达电子科技有限公司

地址：深圳市龙华区福城街道大水坑金湖湾23号2栋2楼

电话：+86-755-23599420 FAX：+86-0755-23599420

SPECIFICATION FOR APPROVAL

1. MECHANICAL DIMENSION (UNIT:mm)

2. SCHEMATICS:

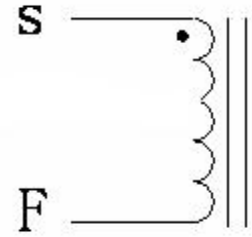
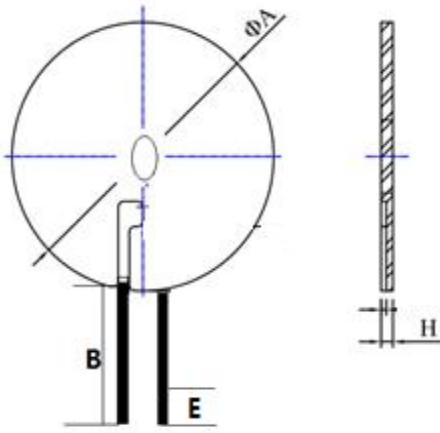

A	B	E	H	
45±1.0	20REF	4±2	1.3ref	

3. WINDING:

STEP	START-FINISH	WIRE TYPE	TURNS	TAPE	REMARK
N1	S-F	0.08*24*2Pmm 2UEW	10TS (Ref)		

4. ELECTRICAL SPECIFICATION:

ITEM	L	DCR	IDC	Q值	HI-POT
TEST	S-F	S-F			
CON	100KHz, 0.25V	AT 25°C			
SPEC	6.5uH ± 10%	50mΩ Max			

5. BILF OF MATERIAL:

NO.	ITEM	MATERIAL SPECIFICATION	MANUFACTURER	SGS NO.
1	CORE	G45L	NANJINGJINNINGCO,LTD	
2	CORE	pc95	NANJINGJINNINGCO,LTD	
3	WIRE	0.08mm*24 2UEW	TAIYI CO.,LTD	
4	TUBE	8mm	LIANCHENG CO.,LTD	
5	EPOXY	9999	CUDAK CO.,LTD	

HRSW ELECTRONICS CO.,LTD		PART NO	
		TITLE	G45开槽+背胶 15mm
DRAWN BY	CHECKED BY		APPROVED BY
谢超	何伟华		韦立红